

TOYOTA

1KZ-TE

ENGINE

REPAIR MANUAL SUPPLEMENT

Aug., 2000

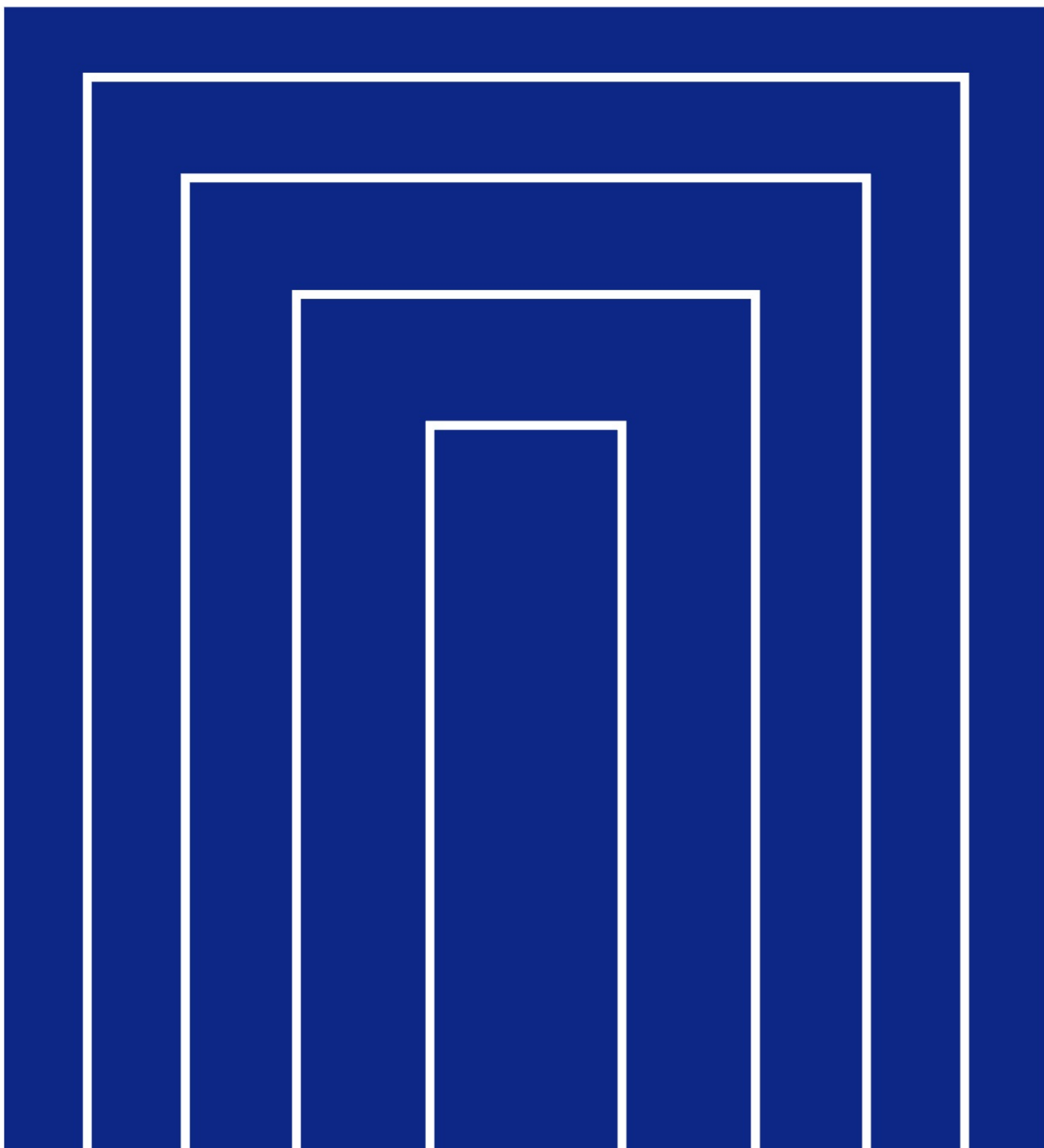

FOREWORD

This repair manual has been prepared to provide information covering general service repairs for the 1KZ-TE engine equipped on the TOYOTA HILUX, 4RUNNER and LAND CRUISER/LAND CRUISER PRADO.

Applicable models: KZN165 series (HILUX)
KZN185 series (4RUNNER)
KZJ90, KZJ95 series (LAND CRUISER/LAND CRUISER PRADO)

Please note that the publications below have also been prepared as relevant service manuals for the components and system in this engine.

Manual Name	Pub.No.
• 1KZ-T Engine Repair Manual	RM353E
• 1KZ-TE Engine Repair Manual	RM710E
• 1KZ-T, 1KZ-TE Engine Repair Manual Supplement	RM522E

All information in this manual is based on the latest product information at the time of publication. However, specifications and procedures are subject to change without notice.

TOYOTA MOTOR CORPORATION

CAUTION

This manual does not include all the necessary items about repair and service. This manual is made for the purpose of the use for the persons who have special techniques and certifications. In the cases that non-specialized or uncertified technicians perform repair or service only using this manual or without proper equipment or tool, that may cause severe injury to you or other people around and also cause damage to your customer's vehicle.

In order to prevent dangerous operation and damages to your customer's vehicle, be sure to follow the instruction shown below.

- Must read this manual thoroughly. It is especially important to have good understanding all the contents written in the PRECAUTION of "IN" section.
- The service method written in this manual is very effective to perform repair and service. When performing the operations following the procedures using this manual, be sure to use tools specified and recommended. If using non-specified or recommended tools and service method, be sure to confirm safety of the technicians and any possibility of causing personal injury or damage to the customer's vehicle before starting the operation.
- If part replacement is necessary, must replace the part with the same part number or equivalent part. Do not replace it with inferior quality.
- It is important to note that this manual contains various "Cautions" and "Notices" that must be carefully observed in order to reduce the risk of personal injury during service or repair, or the possibility that improper service or repair may damage the vehicle or render it unsafe. It is also important to understand that these "Cautions" and "Notices" are not exhaustive, because it is important to warn of all the possible hazardous consequences that might result from failure to follow these instructions.

INTRODUCTION	IN
PREPARATION	PP
SERVICE SPECIFICATIONS	SS
DIAGNOSTICS	DI
ENGINE MECHANICAL	EM
TURBOCHARGING	TC
EMISSION CONTROL	EC
ELECTRONIC CONTROL DIESEL	ED
ENGINE FUEL	FU
COOLING	CO
LUBRICATION	LU
STARTING	ST
ALPHABETICAL INDEX	ID

INTRODUCTION

HOW TO USE THIS MANUAL	IN-1
GENERAL INFORMATION	IN-1
IDENTIFICATION INFORMATION	IN-3
ENGINE SERIAL NUMBER	IN-3
REPAIR INSTRUCTIONS	IN-4
GENERAL INFORMATION	IN-4
FOR ALL OF VEHICLES	IN-8
PRECAUTION	IN-8
HOW TO TROUBLESHOOT ECU	
CONTROLLED SYSTEMS	IN-9
GENERAL INFORMATION	IN-9
HOW TO PROCEED WITH	
TROUBLESHOOTING	IN-10
HOW TO USE THE DIAGNOSTIC CHART AND	
INSPECTION PROCEDURE	IN-20
TERMS	IN-25
ABBREVIATIONS USED IN THIS MANUAL	IN-25

HOW TO USE THIS MANUAL

IN04V-05

GENERAL INFORMATION

1. INDEX

An INDEX is provided on the first page of each section to guide you to the item to be repaired. To assist you in finding your way through the manual, the section title and major heading are given at the top of every page.

2. PRECAUTION

At the beginning of each section, a PRECAUTION is given that pertains to all repair operations contained in that section.

Read these precautions before starting any repair task.

3. TROUBLESHOOTING

TROUBLESHOOTING tables are included for each system to help you diagnose the problem and find the cause. The fundamentals of how to proceed with troubleshooting are described on page IN-9.

Be sure to read this before performing troubleshooting.

4. PREPARATION

Preparation lists the SST (Special Service Tools), recommended tools, equipment, lubricant and SSM (Special Service Materials) which should be prepared before beginning the operation and explains the purpose of each one.

5. REPAIR PROCEDURES

Most repair operations begin with an overview illustration. It identifies the components and shows how the parts fit together.

Example:

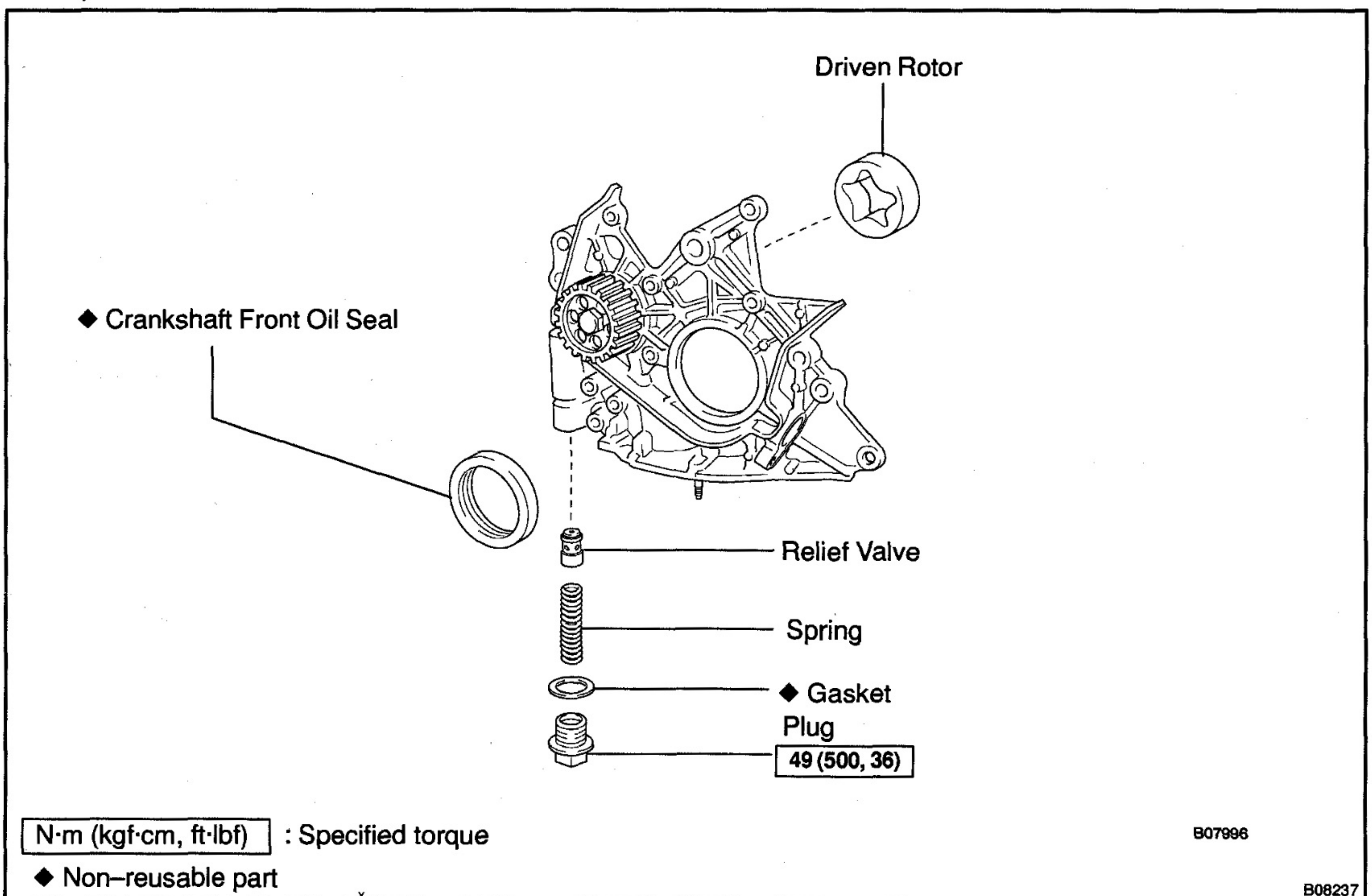

The procedures are presented in a step-by-step format:

- The illustration shows what to do and where to do it.
- The task heading tells what to do.
- The detailed text tells how to perform the task and gives other information such as specifications and warnings.

Example:

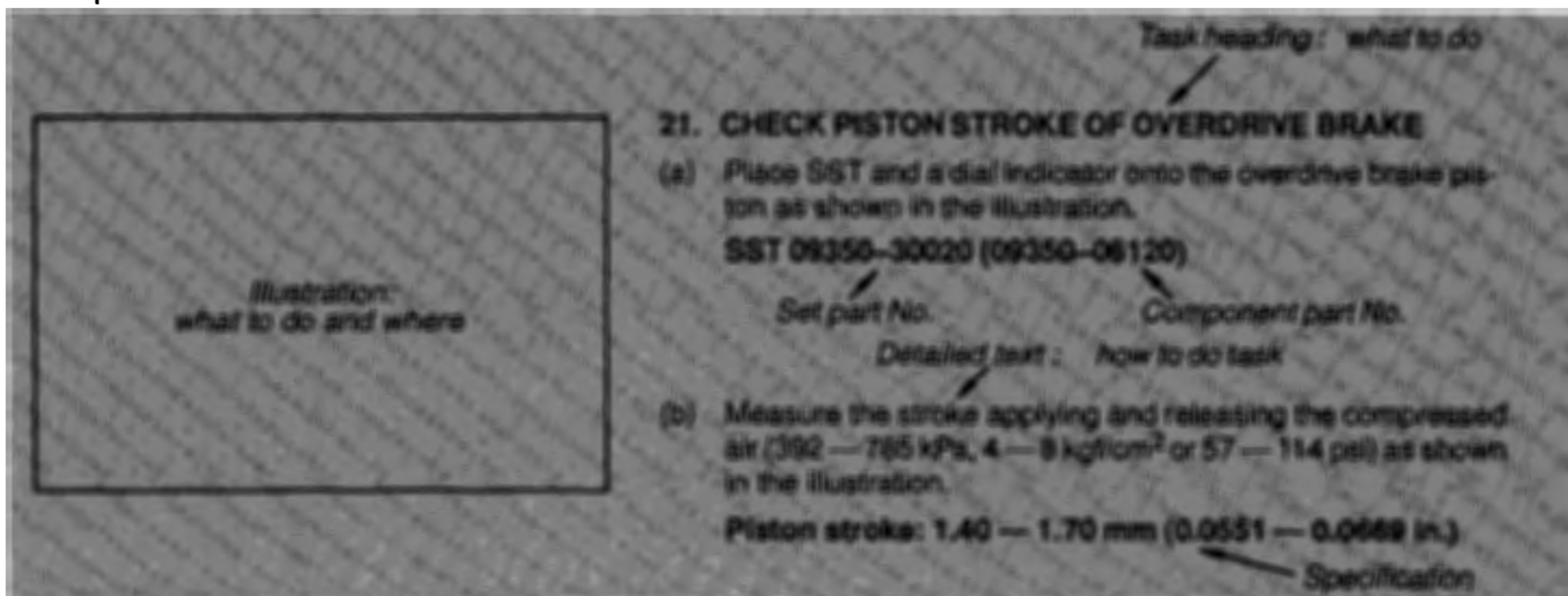

This format provides the experienced technician with a FAST TRACK to the information needed. The upper case task heading can be read at a glance when necessary, and the text below it provides detailed information. Important specifications and warnings always stand out in bold type.

6. REFERENCES

References have been kept to a minimum. However, when they are required you are given the page to refer to.

7. SPECIFICATIONS

Specifications are presented in bold type throughout the text where needed. You never have to leave the procedure to look up your specifications. They are also found in Service Specifications section for quick reference.

8. CAUTIONS, NOTICES, HINTS:

- CAUTIONS are presented in bold type, and indicate there is a possibility of injury to you or other people.
- NOTICES are also presented in bold type, and indicate the possibility of damage to the components being repaired.
- HINTS are separated from the text but do not appear in bold. They provide additional information to help you perform the repair efficiently.

9. SI UNIT

The UNITS given in this manual are primarily expressed according to the SI UNIT (International System of Unit), and alternately expressed in the metric system and in the English System.

Example:

Torque: 30 N·m (310 kgf·cm, 22 ft·lbf)

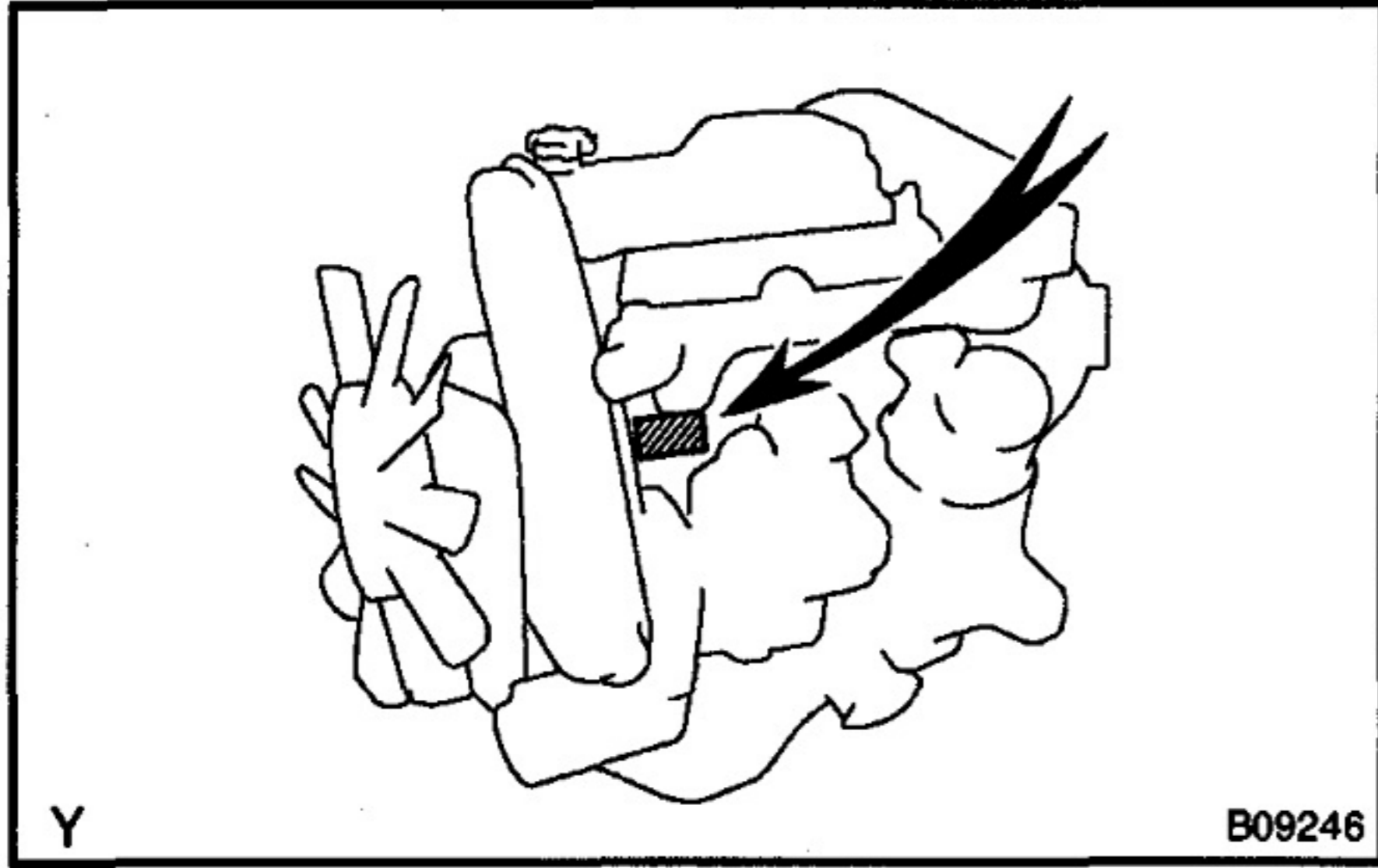

IDENTIFICATION INFORMATION

ENGINE SERIAL NUMBER

IN000-35

The engine serial number is stamped on the engine block as shown.

IN

REPAIR INSTRUCTIONS

IN08X-12

GENERAL INFORMATION

BASIC REPAIR HINT

- (a) Use fender, seat and floor covers to keep the vehicle clean and prevent damage.
- (b) During disassembly, keep parts in the appropriate order to facilitate reassembly.

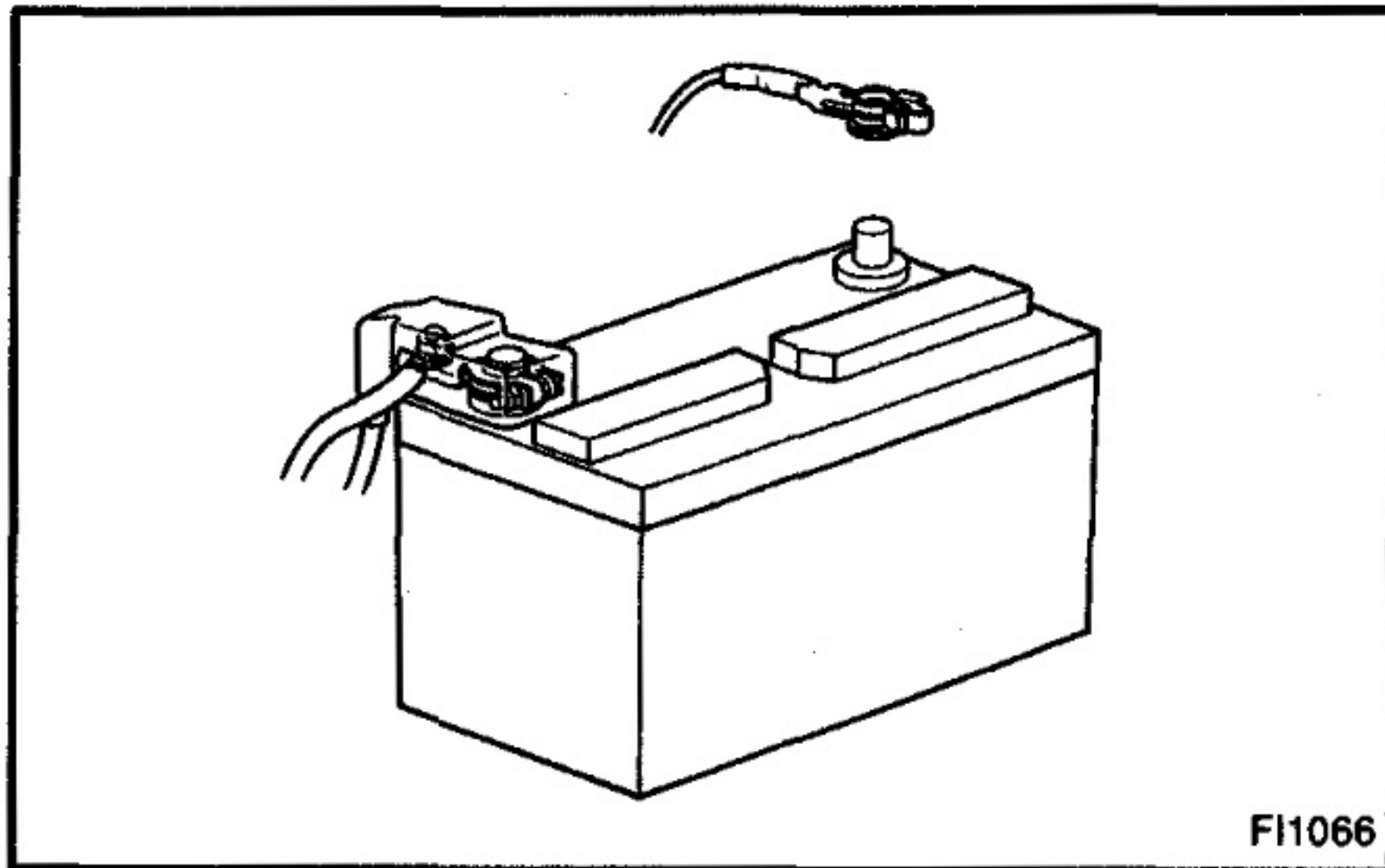

- (c) Observe the following:
 - (1) Before performing electrical work, disconnect the negative (-) terminal cable from the battery.
 - (2) If it is necessary to disconnect the battery for inspection or repair, first disconnect the negative (-) terminal cable.
 - (3) When disconnecting the terminal cable, to prevent damage to the battery terminal, loosen the cable nut and raise the cable straight up without twisting or prying it.
 - (4) Clean the battery terminals and cable ends with a clean shop rag. Do not scrape them with a file or other abrasive objects.
 - (5) Install the cable ends to the battery terminals after loosening the nut, and tighten the nut after installation. Do not use a hammer to tap the cable ends onto the terminals.
 - (6) Be sure the cover for the positive (+) terminal is properly in place.
- (d) Check hose and wiring connectors to make sure that they are secure and correct.
- (e) Non-reusable parts
 - (1) Always replace cotter pins, gaskets, O-rings and oil seals etc. with new ones.
 - (2) Non-reusable parts are indicated in the component illustrations by the "◆" symbol.

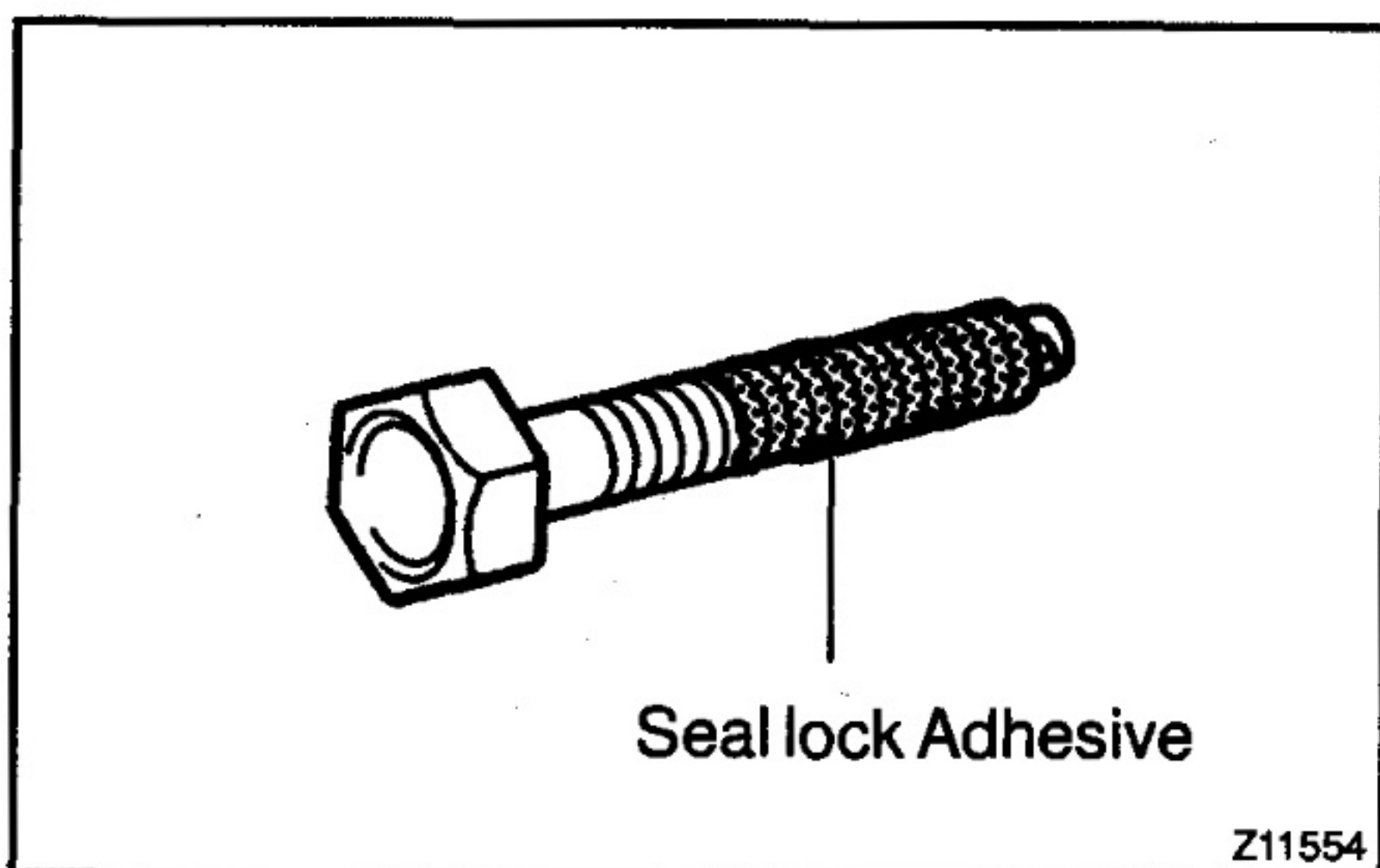

- (f) Precoated parts
Precoated parts are bolts, nuts, etc. that are coated with a seal lock adhesive at the factory.
 - (1) If a precoated part is retightened, loosened or caused to move in any way, it must be recoated with the specified adhesive.
 - (2) When reusing precoated parts, clean off the old adhesive and dry with compressed air. Then apply the specified seal lock adhesive to the bolt, nut or threads.

- (3) Precoated parts are indicated in the component illustrations by the "★" symbol.
- (g) When necessary, use a sealer on gaskets to prevent leaks.
- (h) Carefully observe all specifications for bolt tightening torques. Always use a torque wrench.
- (i) Use of special service tools (SST) and special service materials (SSM) may be required, depending on the nature of the repair. Be sure to use SST and SSM where specified and follow the proper work procedure. A list of SST and SSM can be found in Preparation section in this manual.

IN

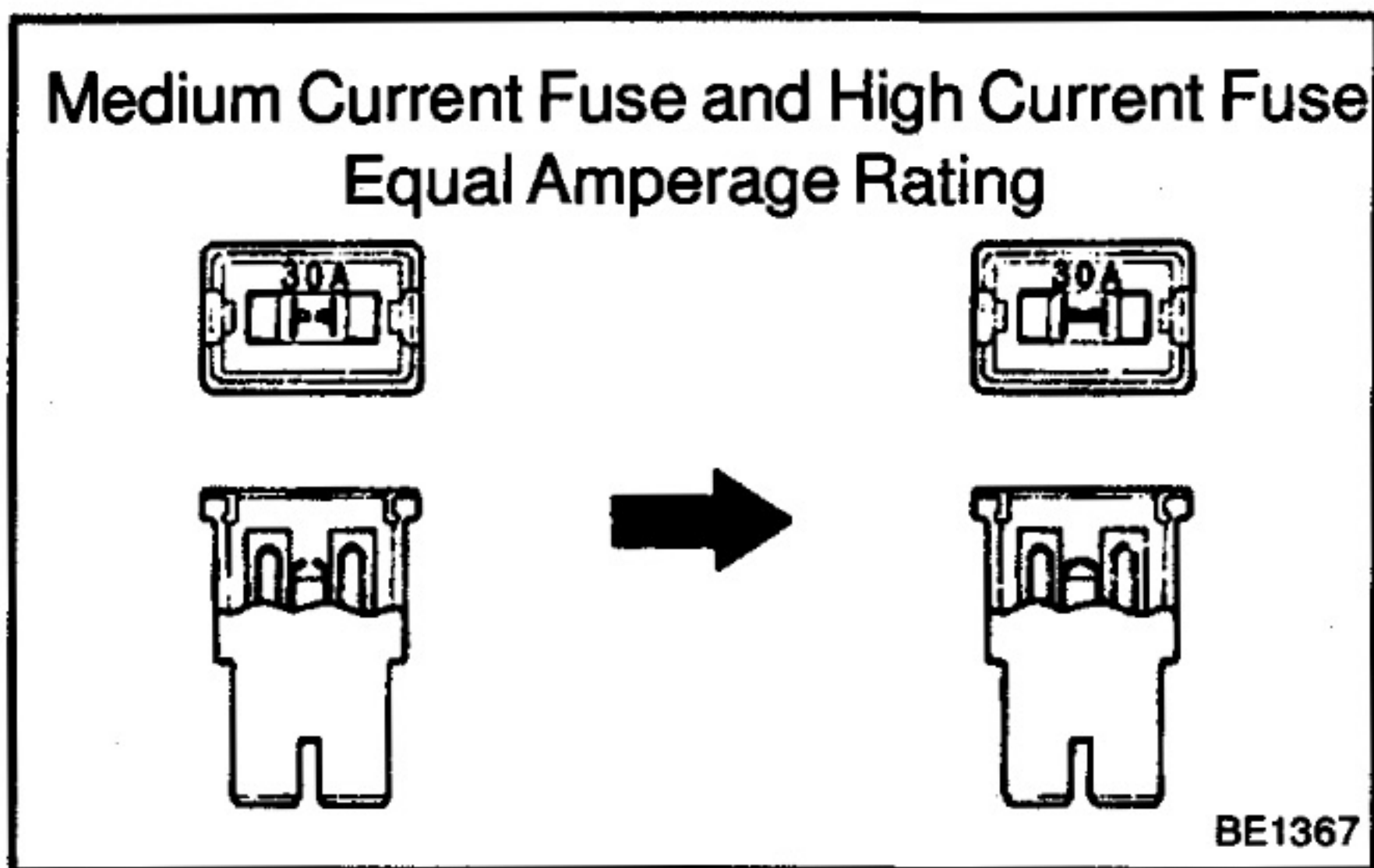

- (j) When replacing fuses, be sure the new fuse has the correct amperage rating. DO NOT exceed the rating or use one with a lower rating.

Illustration	Symbol	Part Name	Abbreviation
<p>BE5594</p>	<p>IN0365</p>	FUSE	FUSE
<p>BE5595</p>	<p>IN0366</p>	MEDIUM CURRENT FUSE	M-FUSE
<p>BE5596</p>	<p>IN0367</p>	HIGH CURRENT FUSE	H-FUSE
<p>BE5597</p>	<p>IN0367</p>	FUSIBLE LINK	FL
<p>BE5598</p>	<p>IN0368</p>	CIRCUIT BREAKER	CB

- (k) Care must be taken when jacking up and supporting the vehicle. Be sure to lift and support the vehicle at the proper locations (As for vehicle lift and support location, please refer to Chassis & Body Repair Manual for each vehicle).
- Cancel the parking brake on the level place and shift the transmission in Neutral (or N position).
 - When jacking up the front wheels of the vehicle at first place stoppers behind the rear wheels.
 - When jacking up the rear wheels of the vehicle at first place stoppers behind the front wheels.
 - When either the front or rear wheels only should be jacked up, set rigid racks and place stoppers in front and behind the other wheels on the ground.
 - After the vehicle is jacked up, be sure to support it on rigid racks. It is extremely dangerous to do any work on a vehicle raised on a jack alone, even for a small job that can be finished quickly.
- (l) Observe the following precautions to avoid damage to the following parts:
- (1) Do not open the cover or case of the ECU unless absolutely necessary. (If the IC terminals are touched, the IC may be destroyed by static electricity.)

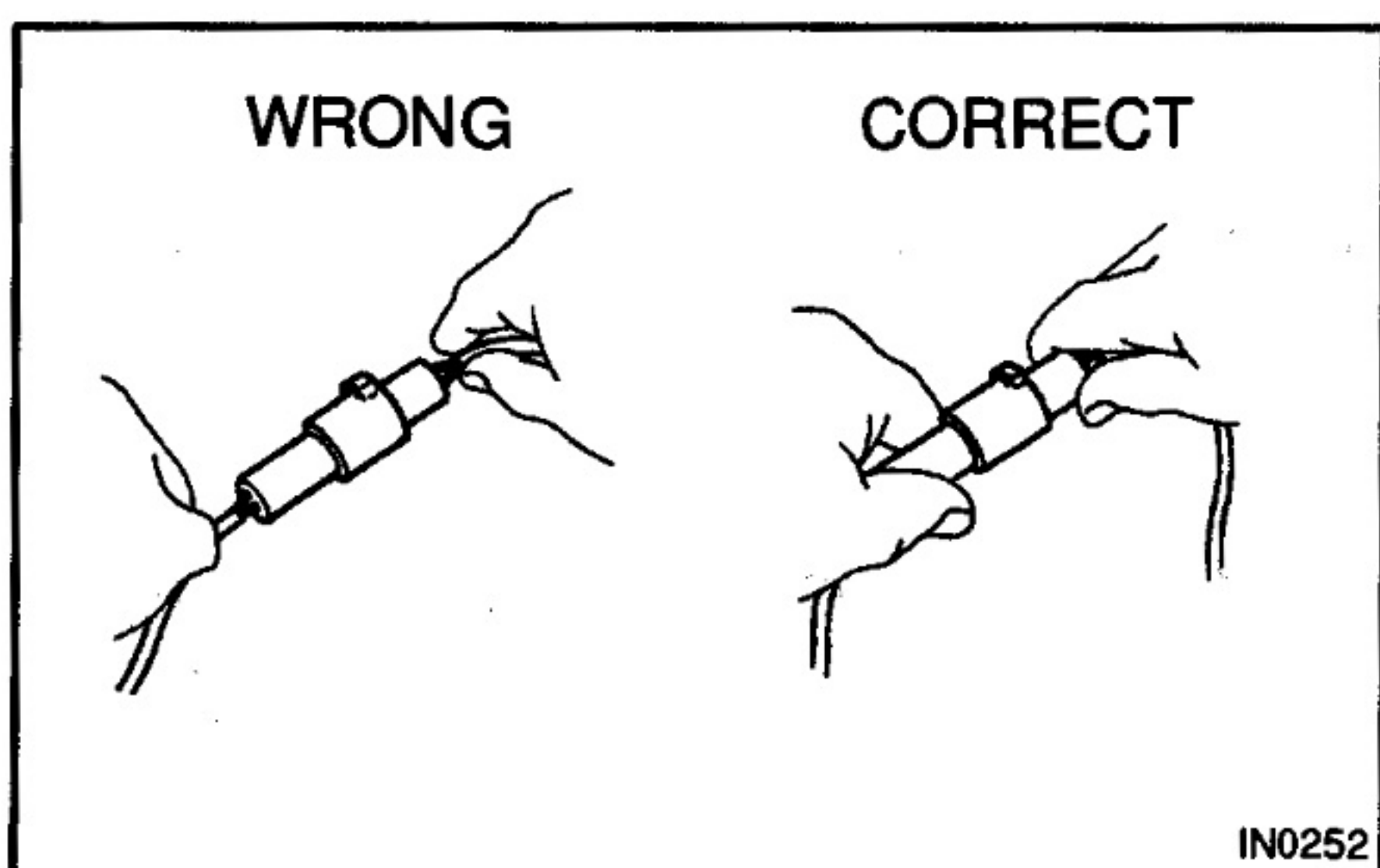
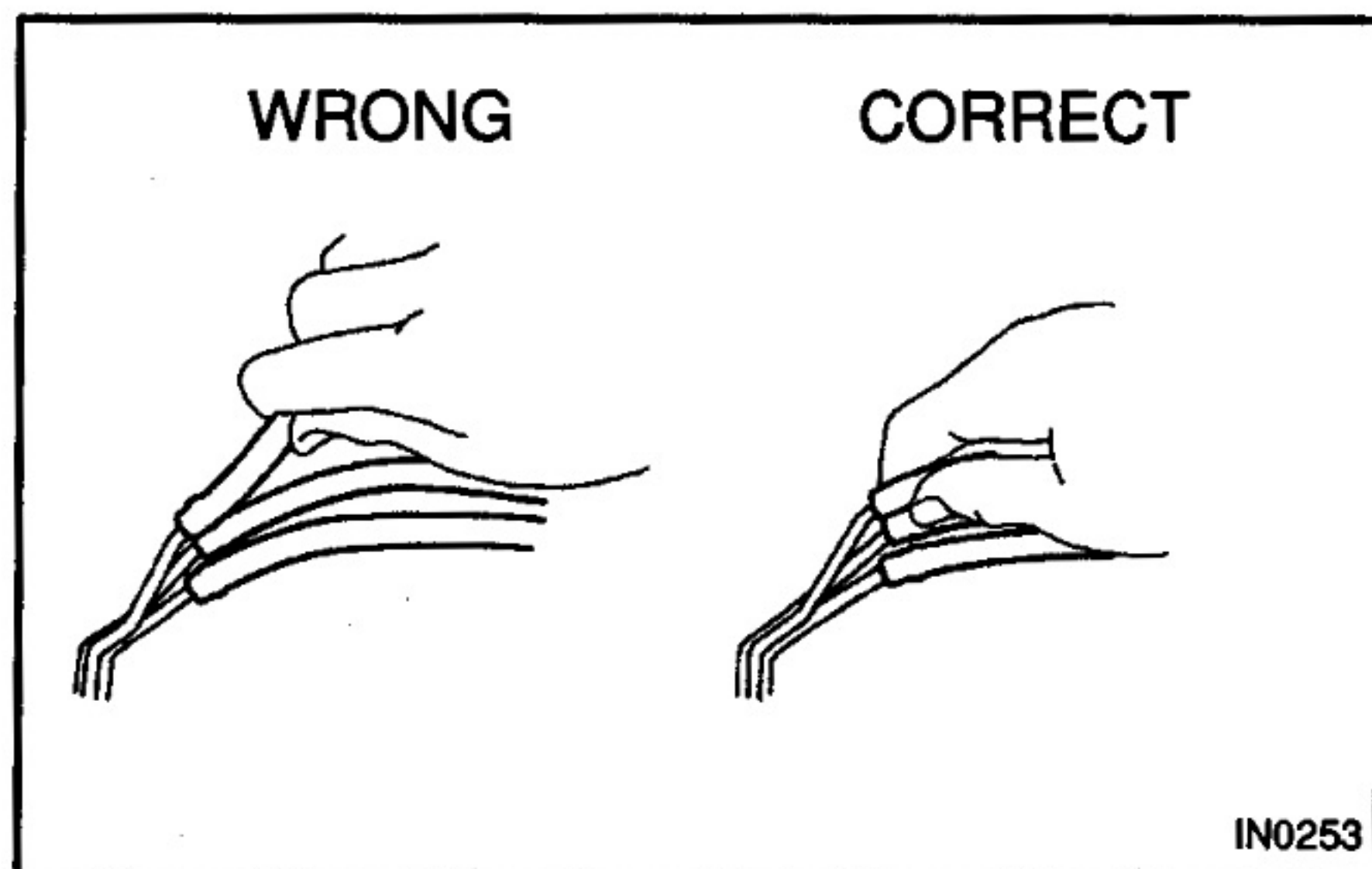

- (2) To disconnect vacuum hoses, pull on the end, not the middle of the hose.
- (3) To pull apart electrical connectors, pull on the connector itself, not the wires.
- (4) Be careful not to drop electrical components, such as sensors or relays. If they are dropped on a hard floor, they should be replaced and not reused.
- (5) When steam cleaning an engine, protect the electronic components, air filter and emissions-related components from water.
- (6) Never use an impact wrench to remove or install temperature switches or temperature sensors.

- (7) When checking continuity at the wire connector, insert the tester probe carefully to prevent terminals from bending.
- (8) When using a vacuum gauge, never force the hose onto a connector that is too large. Use a step-down adapter for adjustment. Once the hose has been stretched, it may leak.

IN

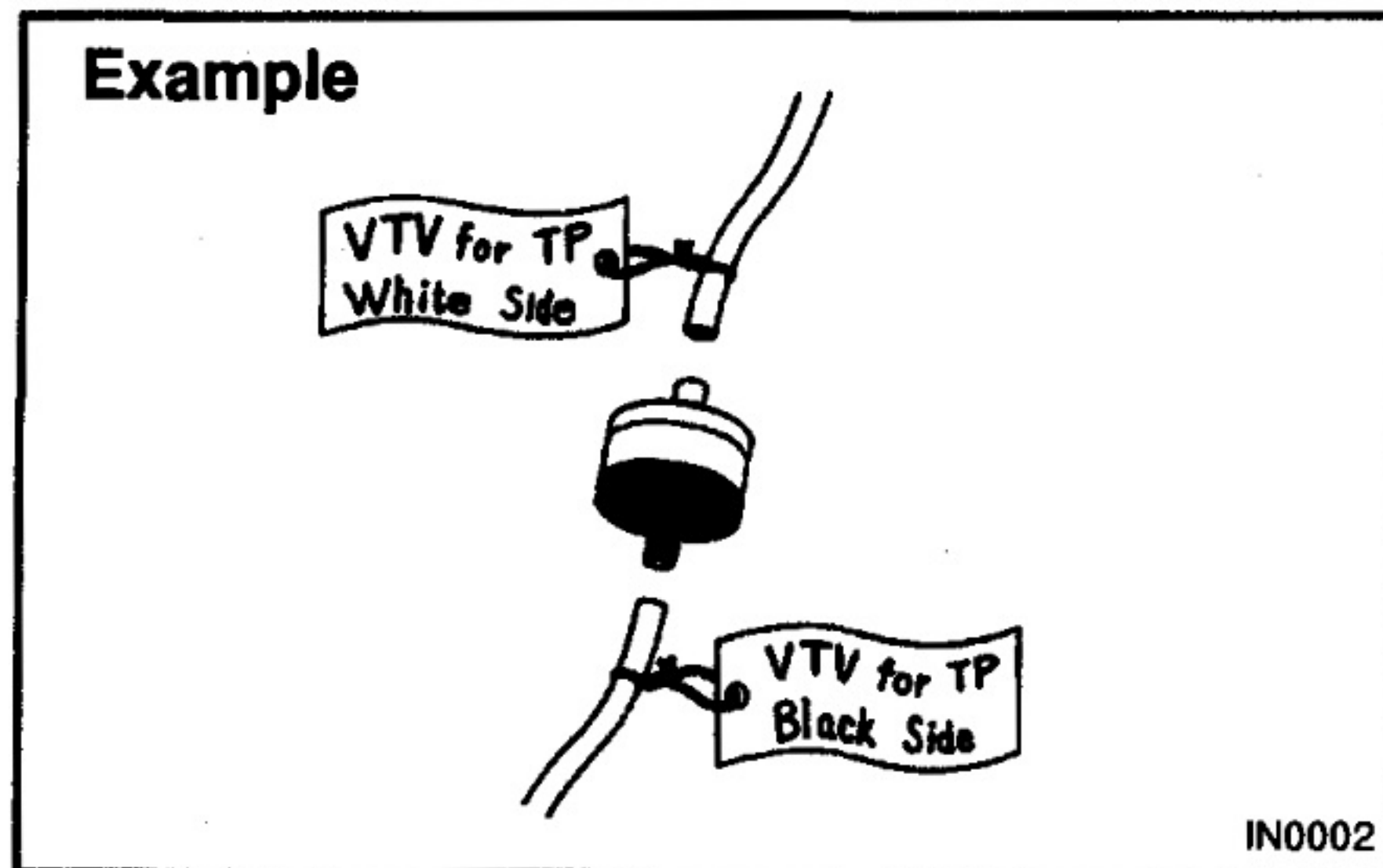

- (m) Tag hoses before disconnecting them:
 - (1) When disconnecting vacuum hoses, use tags to identify how they should be reconnected.
 - (2) After completing a job, double check that the vacuum hoses are properly connected. A label under the hood shows the proper layout.
- (n) Unless otherwise stated, all resistance is measured at an ambient temperature of 20°C (68°F). Because the resistance may be outside specifications if measured at high temperatures immediately after the vehicle has been running, measurement should be made when the engine has cooled down.

FOR ALL OF VEHICLES

PRECAUTION

1. FOR VEHICLES EQUIPPED WITH A CATALYTIC CONVERTER

CAUTION:

If large amounts of unburned gasoline flow into the converter, it may overheat and create a fire hazard. To prevent this, observe the following precautions and explain them to your customer.

- (a) Use only unleaded gasoline.
- (b) Avoid prolonged idling.
Avoid running the engine at idle speed for more than 20 minutes.
- (c) Avoid spark jump test.
 - (1) Perform spark jump test only when absolutely necessary. Perform this test as rapidly as possible.
 - (2) While testing, never race the engine.
- (d) Avoid prolonged engine compression measurement.
Engine compression tests must be done as rapidly as possible.
- (e) Do not run engine when fuel tank is nearly empty.
This may cause the engine to misfire and create an extra load on the converter.
- (f) Avoid coasting with ignition turned off and prolonged braking.
- (g) Do not dispose of used catalyst along with parts contaminated with gasoline or oil.

2. IF VEHICLE IS EQUIPPED WITH MOBILE COMMUNICATION SYSTEM

For vehicles with mobile communication systems such as two-way radios and cellular telephones, observe the following precautions.

- (1) Install the antenna as far as possible away from the ECU and sensors of the vehicle's electronic system.
- (2) Install the antenna feeder at least 20 cm (7.87 in.) away from the ECU and sensors of the vehicle's electronics systems. For details about ECU and sensors locations, refer to the section on the applicable component.
- (3) Avoid winding the antenna feeder together with the other wiring, as much as possible, and also avoid running the antenna feeder parallel with other wire harnesses.
- (4) Check that the antenna and feeder are correctly adjusted.
- (5) Do not install powerful mobile communications system.

3. FOR USING HAND-HELD TESTER

CAUTION:

Observe the following for safety reasons:

- Before using the hand-held tester, the hand-held tester's operator manual should be read thoroughly.
- Be sure to route all cables securely when driving with the hand-held tester connected to the vehicle. (i.e. Keep cables away from feet, pedals, steering wheel and shift lever.)
- Two persons are required when test driving with the hand-held tester, one person to drive the vehicle and one person to operate the hand-held tester.

HOW TO TROUBLESHOOT ECU CONTROLLED SYSTEMS

IN005-34

GENERAL INFORMATION

A large number of ECU controlled systems are used in the HILUX, 4RUNNER and LAND CRUISER/LAND CRUISER PRADO. In general, the ECU controlled system is considered to be a very intricate system requiring a high level of technical knowledge and expert skill to troubleshoot. However, the fact is that if you proceed to inspect the circuits one by one, troubleshooting of these systems is not complex. If you have adequate understanding of the system and a basic knowledge of electricity, accurate diagnosis and necessary repair can be performed to locate and fix the problem. This manual is designed through emphasis of the above standpoint to help service technicians perform accurate and effective troubleshooting, and is compiled for the following major ECU controlled systems:

The troubleshooting procedure and how to make use of it are described on the following pages.

System	Page
Engine	DI-1

FOR USING HAND-HELD TESTER

- Before using the tester, the tester's operator manual should be read thoroughly.
- If the tester cannot communicate with ECU controlled systems when you have connected the cable of the tester to DLC3, turned the ignition switch ON and operated the tester, there is a problem on the vehicle side or tester side.
 - (1) If communication is normal when the tester is connected to another vehicle, inspect the diagnosis data link line (Bus \oplus line) or ECU power circuit of the vehicle.
 - (2) If communication is still not possible when the tester is connected to another vehicle, the problem is probably in the tester itself, so perform the Self Test procedures outline in the Tester Operator's Manual.

HOW TO PROCEED WITH TROUBLESHOOTING

Carry out troubleshooting in accordance with the procedure on the following page. Here, only the basic procedure is shown. Details are provided in diagnostics section, showing the most effective methods for each circuit. Confirm the troubleshooting procedures first for the relevant circuit before beginning troubleshooting of that circuit.

IN

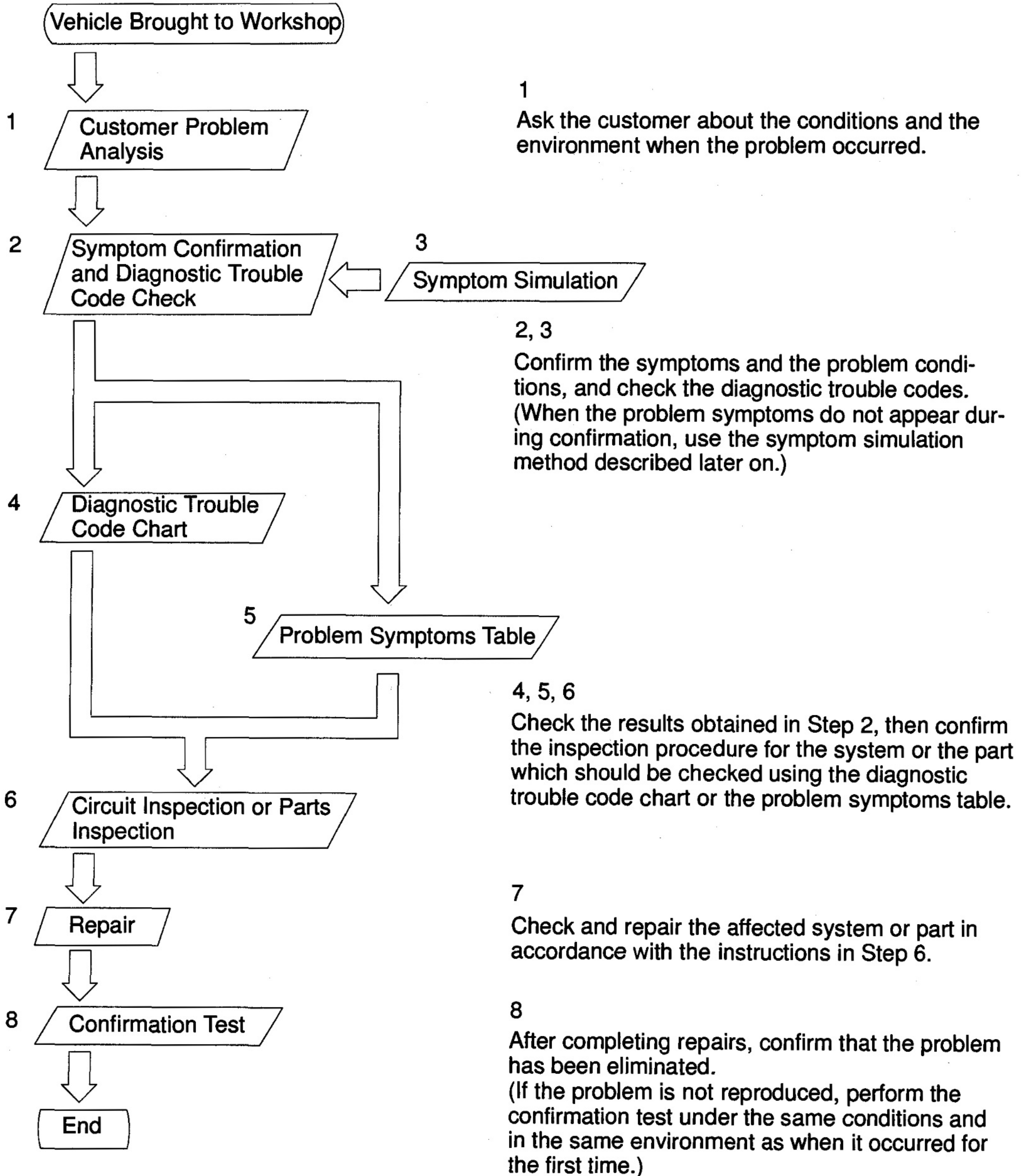

1. CUSTOMER PROBLEM ANALYSIS

In troubleshooting, the problem symptoms must be confirmed accurately and all preconceptions must be cleared away in order to give an accurate judgment. To ascertain just what the problem symptoms are, it is extremely important to ask the customer about the problem and the conditions at the time it occurred.

Important Point in the Problem Analysis:

The following 5 items are important points in the problem analysis. Past problems which are thought to be unrelated and the repair history, etc. may also help in some cases, so as much information as possible should be gathered and its relationship with the problem symptoms should be correctly ascertained for reference in troubleshooting. A customer problem analysis table is provided in the diagnostics section for each system for your use.

- Important Points in the Customer Problem Analysis**
- What ——— Vehicle model, system name
 - When ——— Date, time, occurrence frequency
 - Where ——— Road conditions
 - Under what conditions? ——— Running conditions, driving conditions, weather conditions
 - How did it happen? ——— Problem symptoms

(Sample) Engine control system check sheet.

CUSTOMER PROBLEM ANALYSIS CHECK				
ENGINE CONTROL SYSTEM Check Sheet		Inspector's Name _____		
Customer's Name		Model and Model Year		
Driver's Name		Frame No.		
Data Vehicle Brought in		Engine Model		
License No.		Odometer Reading	km miles	
Problem Symptoms	<input type="checkbox"/> Engine does not Start	<input type="checkbox"/> Engine does not crank	<input type="checkbox"/> No initial combustion	
	<input type="checkbox"/> Difficult to Start	<input type="checkbox"/> No complete combustion		
	<input type="checkbox"/> Poor Idling	<input type="checkbox"/> Engine cranks slowly	<input type="checkbox"/> Other _____	
	<input type="checkbox"/> Poor Driveability	<input type="checkbox"/> Incorrect first idle	<input type="checkbox"/> Idling rpm is abnormal	<input type="checkbox"/> High (rpm) <input type="checkbox"/> Low (rpm)
	<input type="checkbox"/> Engine Stall	<input type="checkbox"/> Rough idling	<input type="checkbox"/> Other _____	
	<input type="checkbox"/> Others	<input type="checkbox"/> Hesitation	<input type="checkbox"/> Back fire	<input type="checkbox"/> Muffler explosion (after-fire) <input type="checkbox"/> Surging
		<input type="checkbox"/> Knocking	<input type="checkbox"/> Other _____	
		<input type="checkbox"/> Soon after starting	<input type="checkbox"/> After accelerator pedal depressed	
		<input type="checkbox"/> After accelerator pedal released	<input type="checkbox"/> During A/C operation	
		<input type="checkbox"/> Shifting from N to D	<input type="checkbox"/> Other _____	
<input type="checkbox"/> Constant <input type="checkbox"/> Sometimes (times per day/month)				

2. SYMPTOM CONFIRMATION AND DIAGNOSTIC TROUBLE CODE CHECK

The diagnostic system in the HILUX, 4RUNNER and LAND CRUISER/LAND CRUISER PRADO fulfills various functions. The first function is the Diagnostic Trouble Code Check in which a malfunction in the signal circuits to the ECU is stored in code in the ECU memory at the time of occurrence, to be output by the technician during troubleshooting. Another function is the Input Signal Check which checks if the signals from various switches are sent to the ECU correctly.

By using these check functions, the problem areas can be narrowed down quickly and troubleshooting can be performed effectively. Diagnostic functions are incorporated in the following systems in the HILUX, 4RUNNER and LAND CRUISER/LAND CRUISER PRADO.

System	Diagnostic Trouble Code Check	Input Signal Check (Sensor Check)	Other Diagnosis Function
Engine	○ (with Check Mode)	○	Diagnostic Test Mode

In diagnostic trouble code check, it is very important to determine whether the problem indicated by the diagnostic trouble code is still occurring or occurred in the past but returned to normal at present. In addition, it must be checked in the problem symptom check whether the malfunction indicated by the diagnostic trouble code is directly related to the problem symptom or not. For this reason, the diagnostic trouble codes should be checked before and after the symptom confirmation to determine the current conditions, as shown in the table below. If this is not done, it may, depending on the case, result in unnecessary troubleshooting for normally operating systems, thus making it more difficult to locate the problem, or in repairs not pertinent to the problem. Therefore, always follow the procedure in correct order and perform the diagnostic trouble code check.

DIAGNOSTIC TROUBLE CODE CHECK PROCEDURE

Diagnostic Trouble Code Check (Make a note of and then clear)	Confirmation of Symptoms	Diagnostic Trouble Code Check	Problem Condition
Diagnostic Trouble Code Display	Problem symptoms exist	Same diagnostic trouble code is displayed	Problem is still occurring in the diagnostic circuit
	→ No problem symptoms exist	Normal code is displayed	The problem is still occurring in a place other than in the diagnostic circuit. (The diagnostic trouble code displayed first is either for a past problem or it is a secondary problem.)
Normal Code Display	→ Problem symptoms exist	Normal code is displayed	The problem is still occurring in a place other than in the diagnostic circuit.
	→ No problem symptoms exist	Normal code is displayed	The problem occurred in a place other than in the diagnostic circuit in the past.

Taking into account the points on the previous page, a flow chart showing how to proceed with troubleshooting using the diagnostic trouble code check is shown below. This flow chart shows how to utilize the diagnostic trouble code check effectively, then by carefully checking the results, indicates how to proceed either to diagnostic trouble code troubleshooting or to troubleshooting of problem symptoms table.

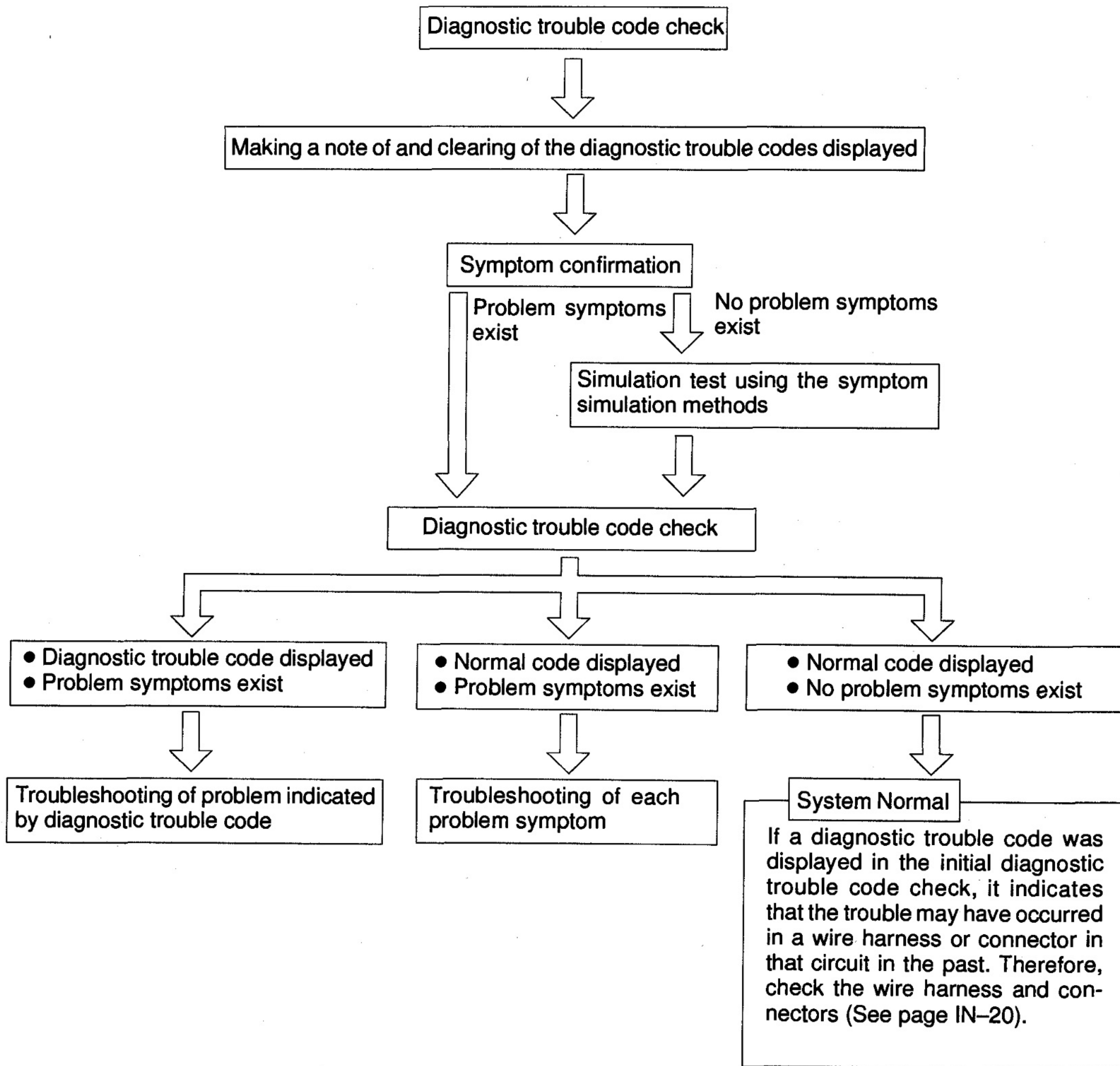



3. SYMPTOM SIMULATION

The most difficult case in troubleshooting is when there are no problem symptoms occurring. In such cases, a thorough customer problem analysis must be carried out, then simulate the same or similar conditions and environment in which the problem occurred in the customer's vehicle. No matter how much experience a technician has, or how skilled he may be, if he proceeds to troubleshoot without confirming the problem symptoms he will tend to overlook something important in the repair operation and make a wrong guess somewhere, which will only lead to a standstill. For example, for a problem which only occurs when the engine is cold, or for a problem which occurs due to vibration caused by the road during driving, etc., the problem can never be determined so long as the symptoms are confirmed with the engine hot condition or the vehicle at a standstill. Since vibration, heat or water penetration (moisture) is likely to cause for problem which is difficult to reproduce, the symptom simulation tests introduced here are effective measures in that the external causes are applied to the vehicle in a stopped condition.

Important Points in the Symptom Simulation Test:

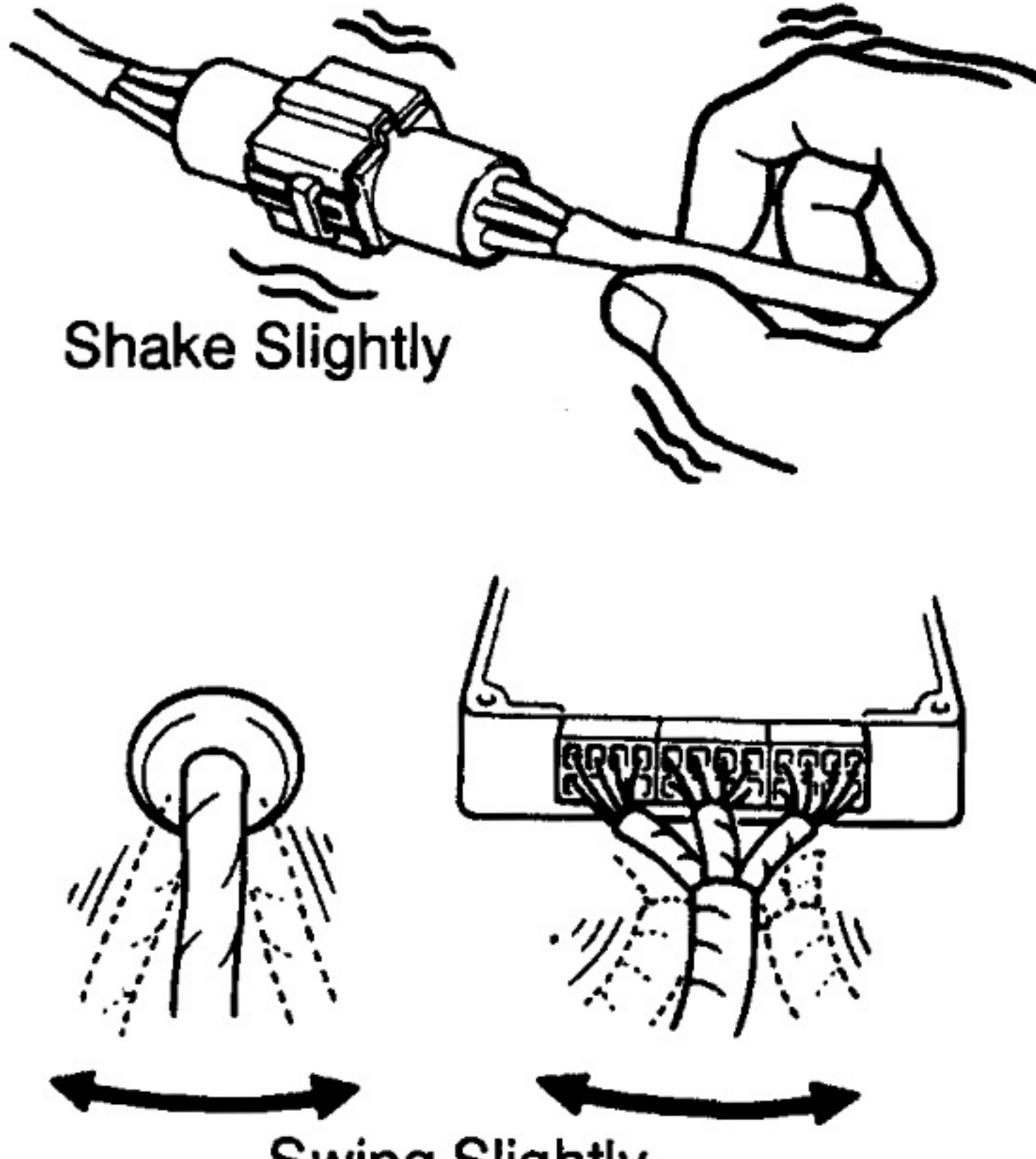
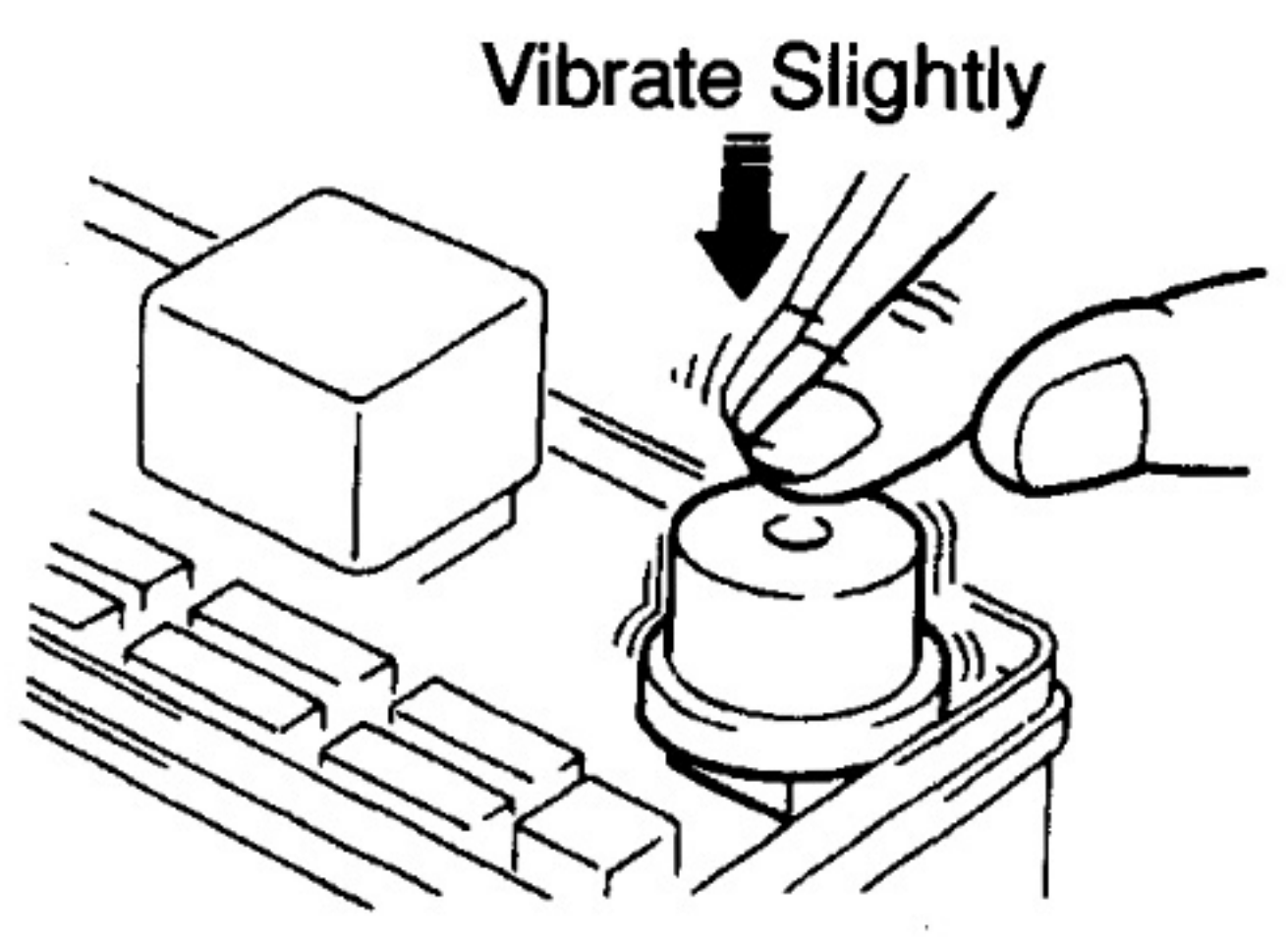
In the symptom simulation test, the problem symptoms should of course be confirmed, but the problem area or parts must also be found out. To do this, narrow down the possible problem circuits according to the symptoms before starting this test and connect a tester beforehand. After that, carry out the symptom simulation test, judging whether the circuit being tested is defective or normal and also confirming the problem symptoms at the same time. Refer to the problem symptoms table for each system to narrow down the possible causes of the symptom.

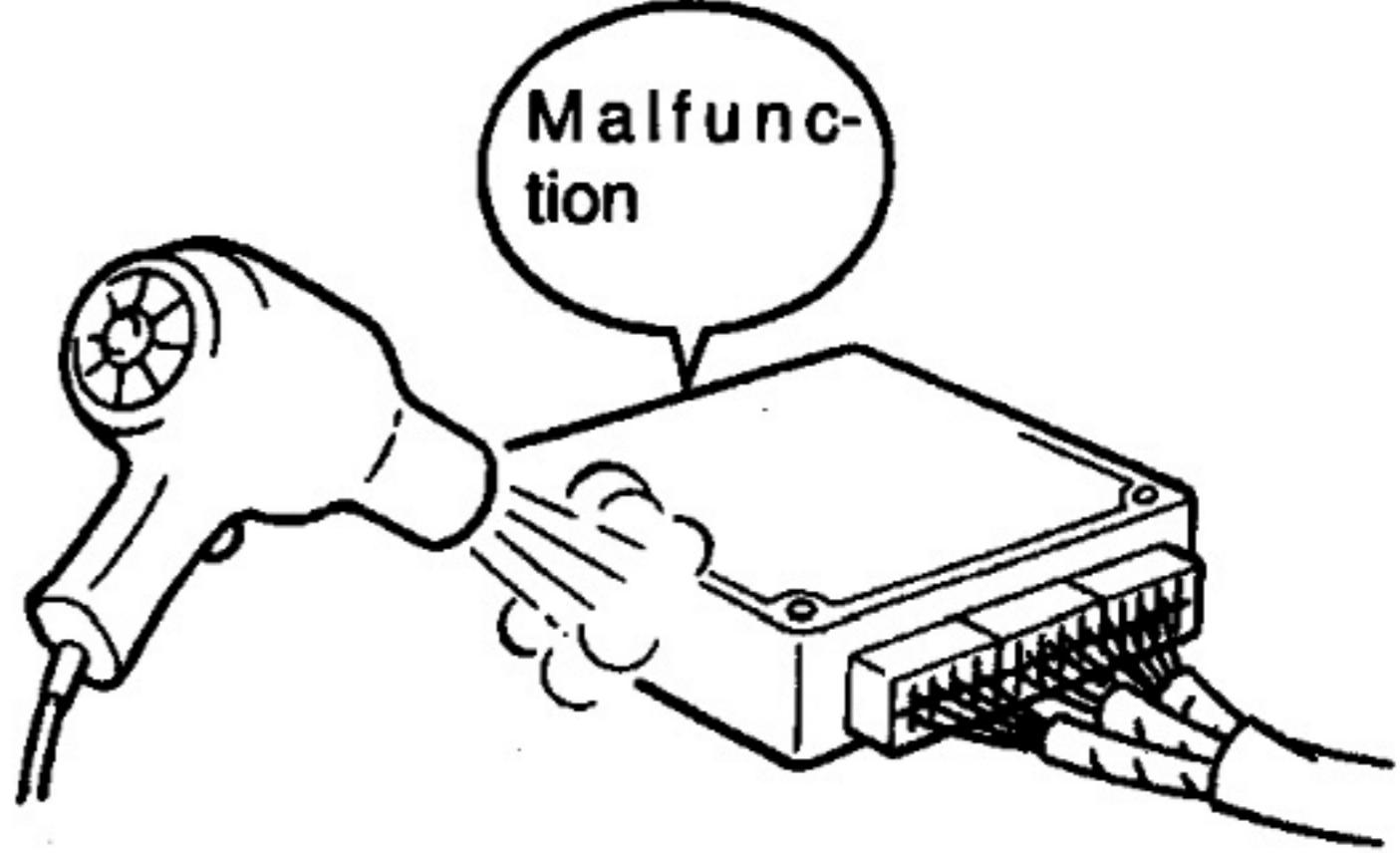
<p>1</p>	<p>VIBRATION METHOD: When vibration seems to be the major cause.</p>
<p>CONNECTORS Slightly shake the connector vertically and horizontally.</p> <p>WIRE HARNESS Slightly shake the wire harness vertically and horizontally. The connector joint, fulcrum of the vibration, and body through portion are the major areas to be checked thoroughly.</p>	 <p>F12331 F12332</p>
<p>PARTS AND SENSOR Apply slight vibration with a finger to the part of the sensor considered to be the problem cause and check that the malfunction occurs.</p> <p>HINT: Applying strong vibration to relays may result in open relays.</p>	 <p>F12330</p>

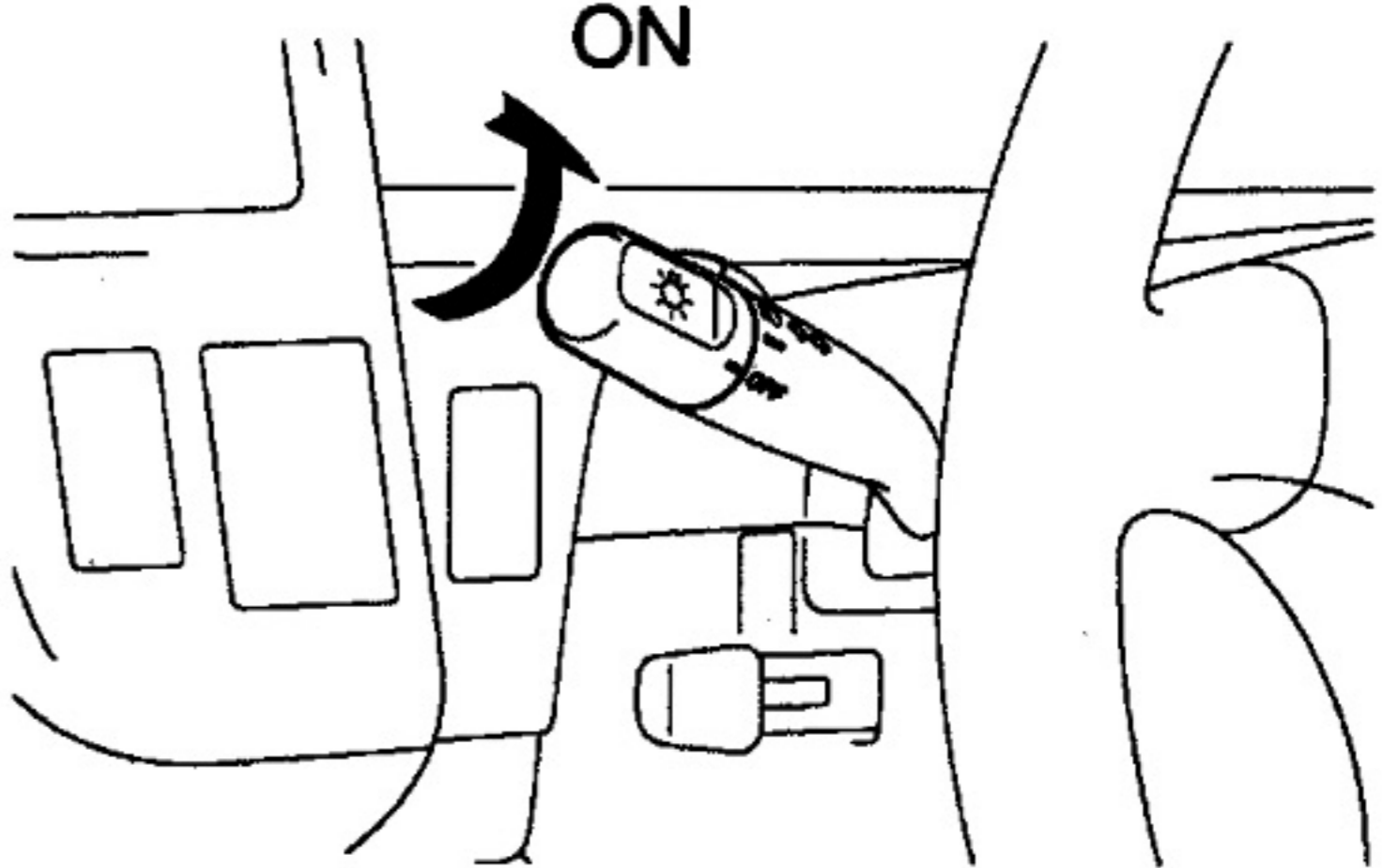
<p>2</p>	<p>HEAT METHOD: When the problem seems to occur when the suspect area is heated.</p>
<p>Heat the component that is the likely cause of the malfunction with a hair dryer or similar object. Check to see if the malfunction occurs.</p> <p>NOTICE:</p> <p>(1) Do not heat to more than 60°C (140°F). (Temperature is limited not to damage the components.)</p> <p>(2) Do not apply heat directly to parts in the ECU.</p>	 <p>F12334</p>
<p>3</p>	<p>WATER SPRINKLING METHOD: When the malfunction seems to occur on a rainy day or in a high-humidity condition.</p>
<p>Sprinkle water onto the vehicle and check to see if the malfunction occurs.</p> <p>NOTICE:</p> <p>(1) Never sprinkle water directly into the engine compartment, but indirectly change the temperature and humidity by applying water spray onto the radiator front surface.</p> <p>(2) Never apply water directly onto the electronic components.</p> <p>HINT:</p> <p>If a vehicle is subject to water leakage, the leaked water may contaminate the ECU. When testing a vehicle with a water leakage problem, special caution must be taken.</p>	 <p>F16649</p>
<p>4</p>	<p>OTHER: When a malfunction seems to occur when electrical load is excessive.</p>
<p>Turn on all electrical loads including the heater blower, head lights, rear window defogger, etc. and check to see if the malfunction occurs.</p>	 <p>B02389</p>

4. DIAGNOSTIC TROUBLE CODE CHART

The inspection procedure is shown in the table below. This table permits efficient and accurate troubleshooting using the diagnostic trouble codes displayed in the diagnostic trouble code check. Proceed with troubleshooting in accordance with the inspection procedure given in the diagnostic chart corresponding to the diagnostic trouble codes displayed. The engine diagnostic trouble code chart is shown below as an example.

- **DTC No.**
Indicates the diagnostic trouble code.
- **Page or Instructions**
Indicates the page where the inspection procedure for each circuit is to be found, or gives instructions for checking and repairs.

- **Trouble Area**
Indicates the suspect area of the problem.

- **Detection Item**
Indicates the system of the problem or contents of the problem.

DIAGNOSTIC TROUBLE CODE CHART				
HINT: Parameters listed in the chart may not be exactly the same as your reading due to the type of instrument or other factors. If a malfunction code is displayed during the DTC check in check mode, check the circuit for the code listed in the table below. For details of each code, turn to the page referred to under the "See page" for the respective "DTC No." in the DTC chart.				
DTC No. (See page)	Detection Item	Trouble Area	CHK ENG *1	*Memory
P0105/31 (DI-12)	Vacuum Sensor Circuit Malfunction	<ul style="list-style-type: none"> ● Open or short in vacuum sensor circuit ● Vacuum sensor ● Engine ECU 	○	○
P0110/24 (DI-28)	Intake Air Temp. Circuit Malfunction	<ul style="list-style-type: none"> ● Open or short in intake air temp. sensor circuit ● Intake air temp. sensor ● Engine ECU 	-	○
P0115/22 (DI-31)	Water Temp. Circuit Malfunction	<ul style="list-style-type: none"> ● Open or short in water temp. sensor circuit ● Water temp. sensor ● Engine ECU 	○	○
P0120/41 (DI-32)	Throttle Position Sensor Circuit Malfunction	<ul style="list-style-type: none"> ● Open or short in throttle position sensor circuit ● Throttle position sensor ● Engine ECU 	-	○
		<ul style="list-style-type: none"> ● Open or short in Oxygen sensor circuit ● Oxygen sensor 		

5. PROBLEM SYMPTOMS TABLE

The suspected circuits or parts for each problem symptom are shown in the table below. Use this table to troubleshoot the problem when a "Normal" code is displayed in the diagnostic trouble code check but the problem is still occurring. Numbers in the table indicate the inspection order in which the circuits or parts should be checked.

HINT:

When the problem is not detected by the diagnostic system even though the problem symptom is present, it is considered that the problem is occurring outside the detection range of the diagnostic system, or that the problem is occurring in a system other than the diagnostic system.

● Page
Indicates the page where the flow chart for each circuit is located.

● Circuit Inspection, Inspection Order
Indicates the circuit which needs to be checked for each problem symptom. Check in the order indicated by the numbers.

● Problem Symptom

● Circuit or Part Name
Indicates the circuit or part which needs to be checked.

PROBLEM SYMPTOMS TABLE		
Symptom	Suspected Area	See page
Engine does not crank (Does not start)	1. Starter and starter relay	ST-12, 13
No initial combustion (Does not start)	1. Engine ECU power source circuit 2. Fuel pump control circuit 3. Engine ECU	DI-124 DI-127 IN-30
No complete combustion (Does not start)	1. Fuel pump control circuit	DI-127
Engine cranks normally (Difficult to start)	1. Starter signal circuit 2. Fuel pump control circuit 3. Compression	DI-121 DI-127 EM-3
Cold engine (Difficult to start)	1. Starter signal circuit 2. Fuel pump control circuit	DI-121 DI-127
Hot engine	1. Starter signal circuit 2. Fuel pump control circuit	DI-121 DI-127
High engine idle speed (Poor idling)	1. A/C signal circuit (Compressor circuit) 2. Engine ECU power source circuit	AC-54 DI-124
High engine idle speed (Poor idling)	1. A/C signal circuit 2. Fuel pump control circuit	
High engine idle speed (Poor idling)	1. Compression 2. Fuel pump control circuit	

6. CIRCUIT INSPECTION

How to read and use each page is shown below.

● Diagnostic Trouble Code No. and Detection Item

● Circuit Description
The major role and operation, etc. of the circuit and its component parts are explained.

DTC	P0325/52	Knock Sensor Circuit Malfunction
------------	-----------------	---

CIRCUIT DESCRIPTION
Knock sensor are fitted to the cylinder block to detect engine knocking. This sensor contains a piezoelectric element which generates a voltage when it becomes deformed, which occurs when the cylinder block vibrates due to knocking.

DTC No.	DTC Detection Condition	Trouble Area
P0325/52	No knock sensor 1 signal to engine ECU with engine speed between 1,700 rpm and 5,200 rpm	<ul style="list-style-type: none"> ● Open or short in knock sensor circuit ● Knock sensor (Looseness) ● Engine ECU

● Indicates the diagnostic trouble code, diagnostic trouble code set parameter and suspect area of the problem.

WIRING DIAGRAM

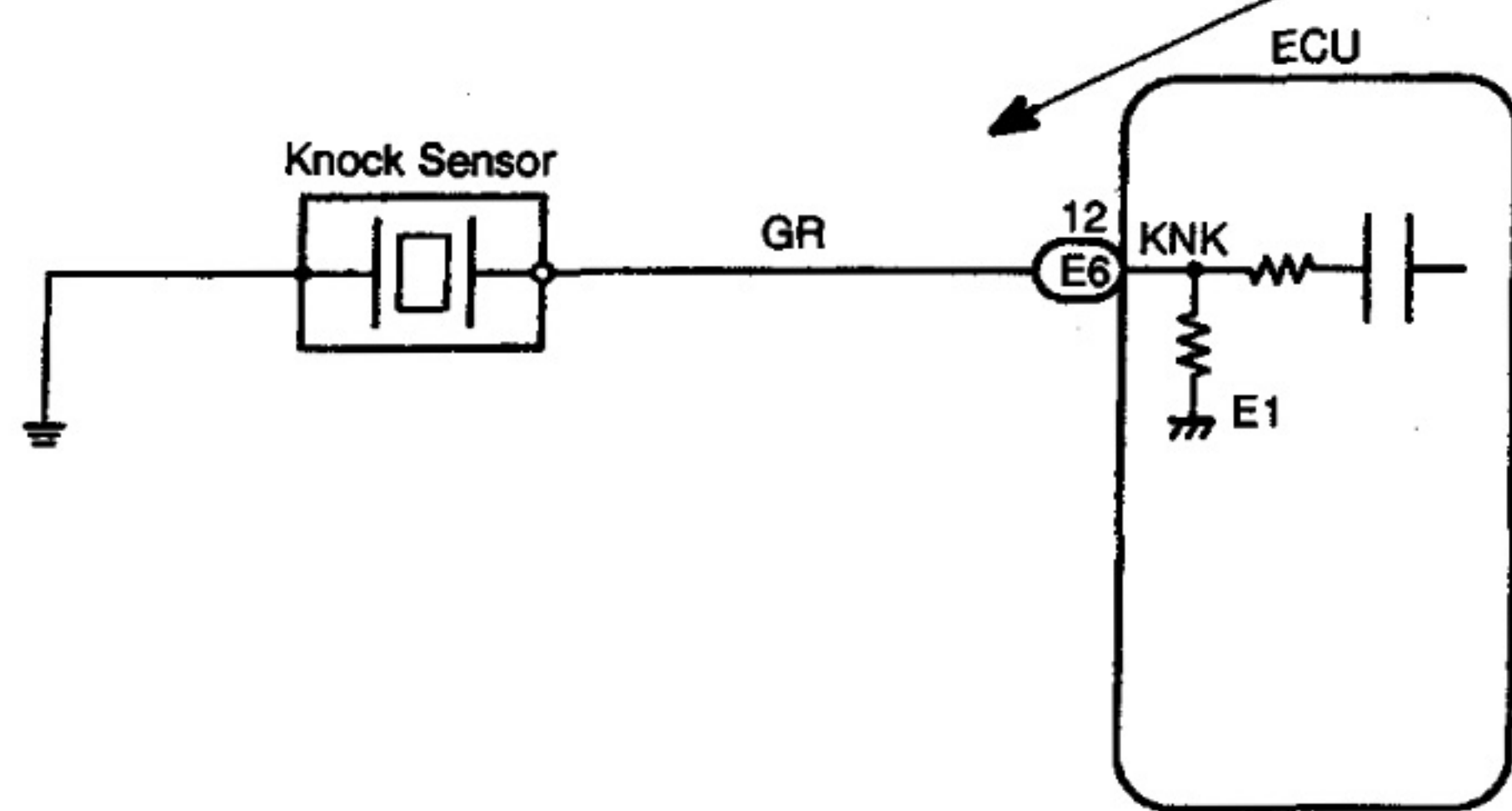

● Wiring Diagram
This shows a wiring diagram of the circuit. Use this diagram together with ELECTRICAL WIRING DIAGRAM to thoroughly understand the circuit.
Wire colors are indicated by an alphabetical code.
B = Black, L = Blue, R = Red, BR = Brown, LG = Light Green, V = Violet, G = Green, O = Orange, W = White, GR = Gray, P = Pink, Y = Yellow
The first letter indicates the basic wire color and the second letter indicates the color of the stripe.

- Indicates the position of the ignition switch during the check.

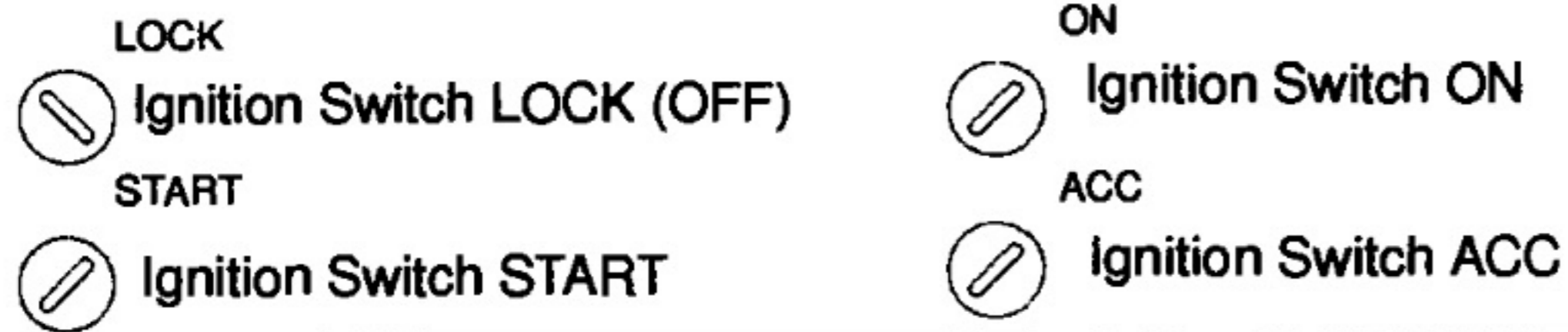

- Inspection Procedure**
Use the inspection procedure to determine if the circuit is normal or abnormal, and if it is abnormal, use it to determine whether the problem is located in the sensors, actuators, wire harness or ECU.

INSPECTION PROCEDURE

1 Check continuity between terminal KNK of ECU connector and body ground.

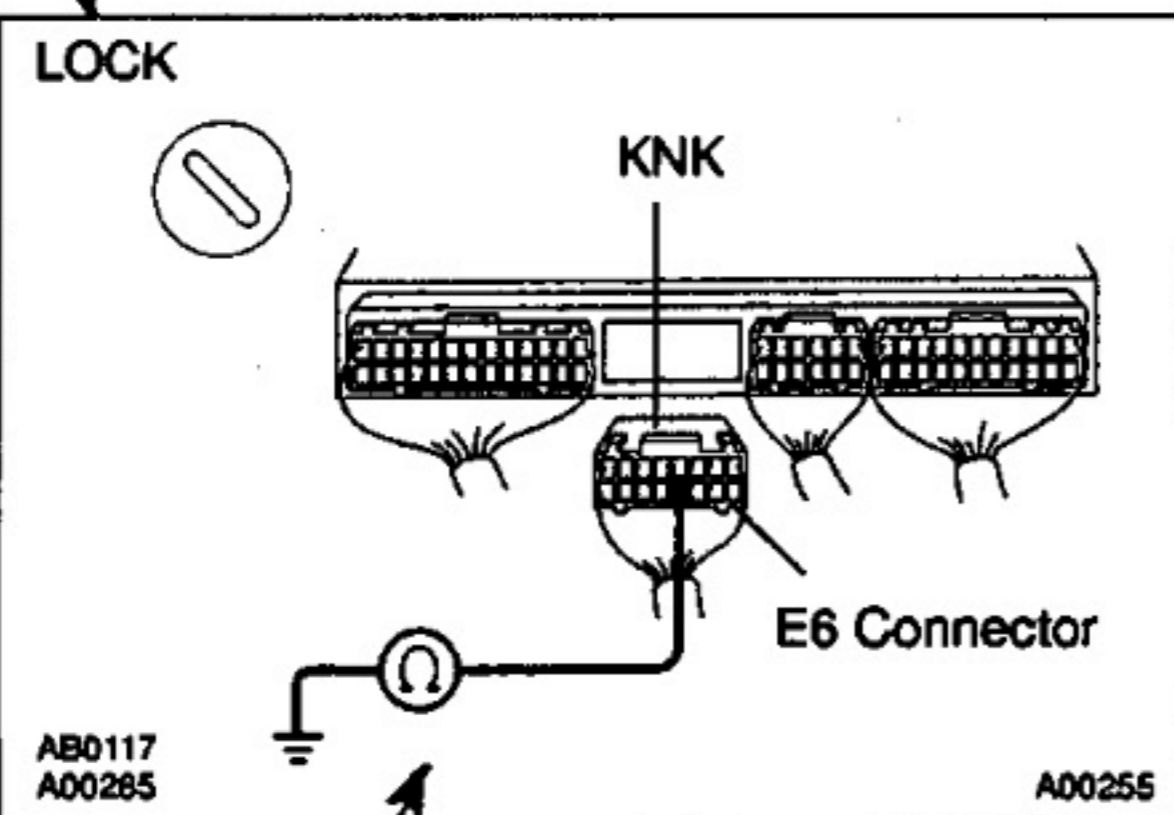

PREPARATION:

- (a) Remove the glove compartment (See page FI-37).
- (b) Disconnect the E6 connector from the ECU.

CHECK:

Measure the resistance between terminal KNK of the ECU connector and body ground.

OK:

Resistance: 1 MΩ or higher

OK → Go to step 3.

NG

2 Check knock sensor (See page FI-34).

OK → Replace knock sensor.

- Indicates the place to check the voltage or resistance.
- Indicates the connector position to checked, from the front or back side.

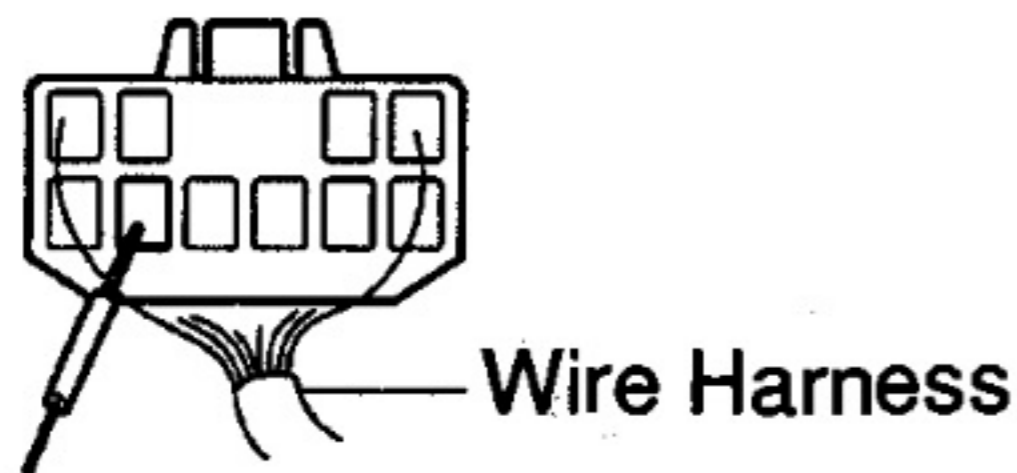

Check from the connector back side (with harness).



Check from the connector front side (without harness). In this case, care must be taken not to bend the terminals.

- Indicates the condition of the connector of ECU during the check.

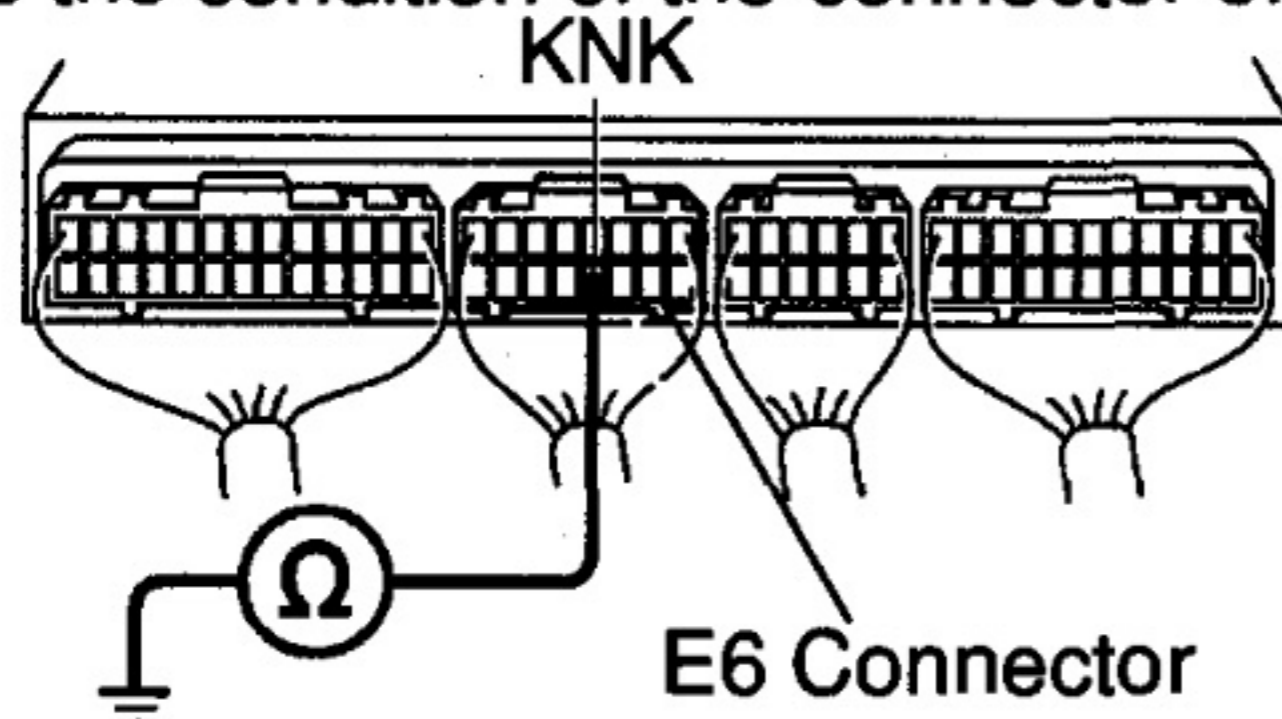

Connector being checked is connected.

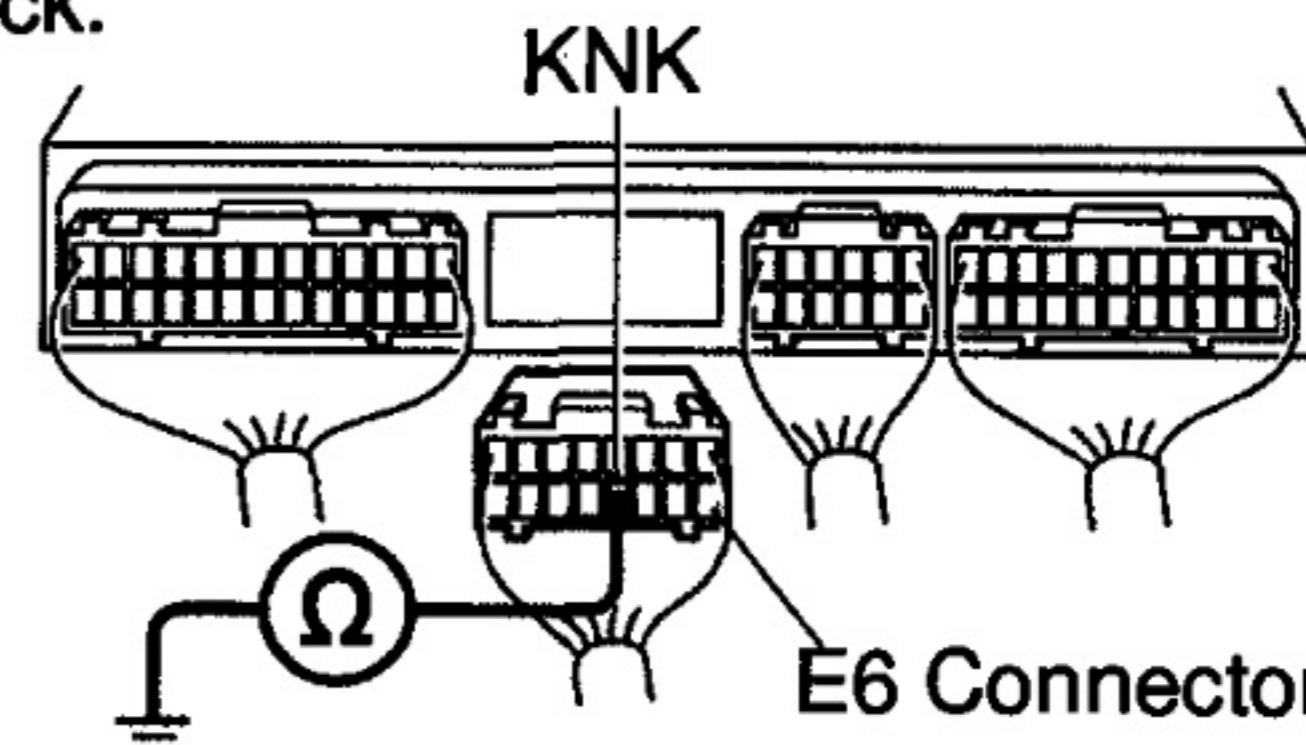

Connector being checked is disconnected.

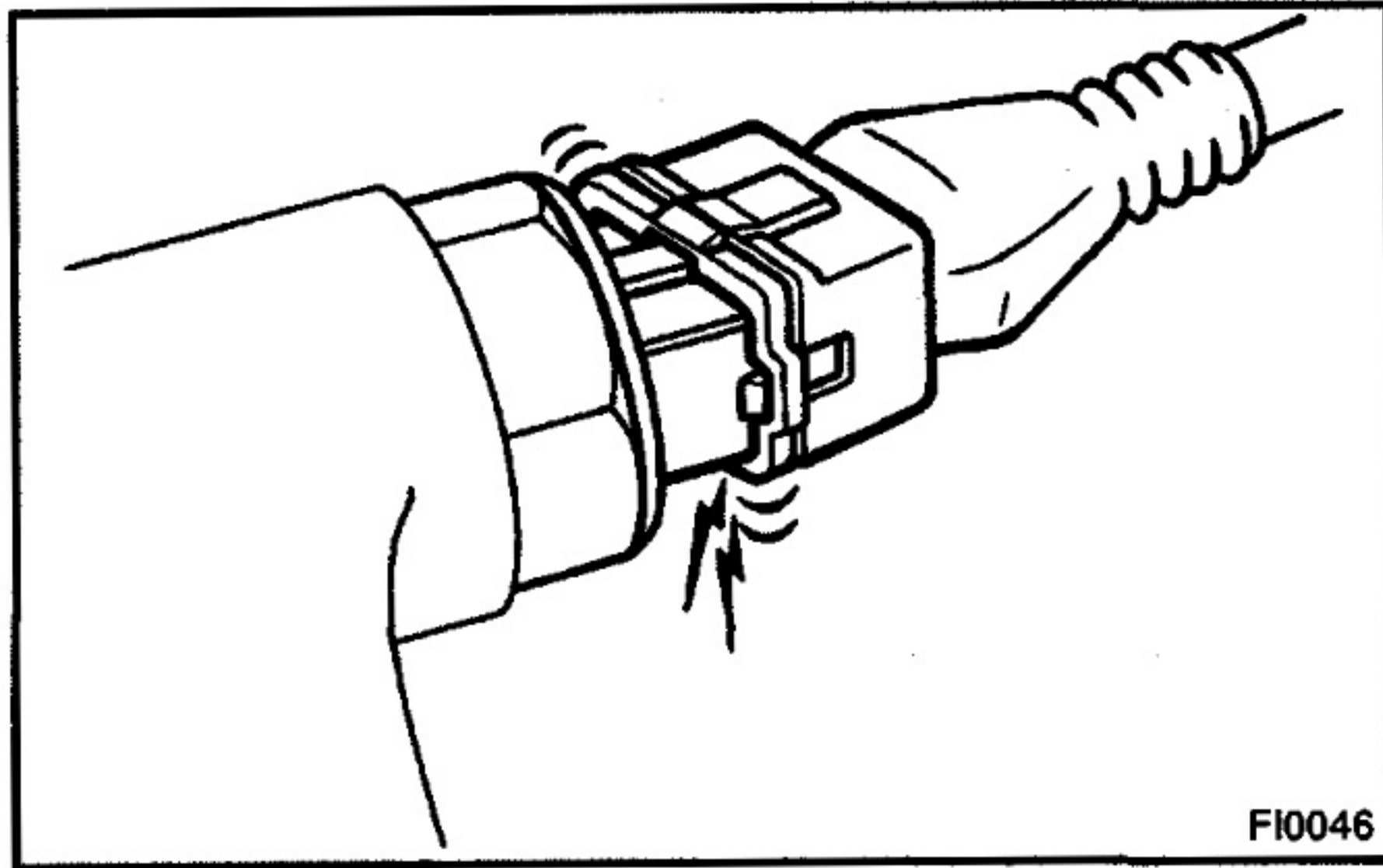

FI0046

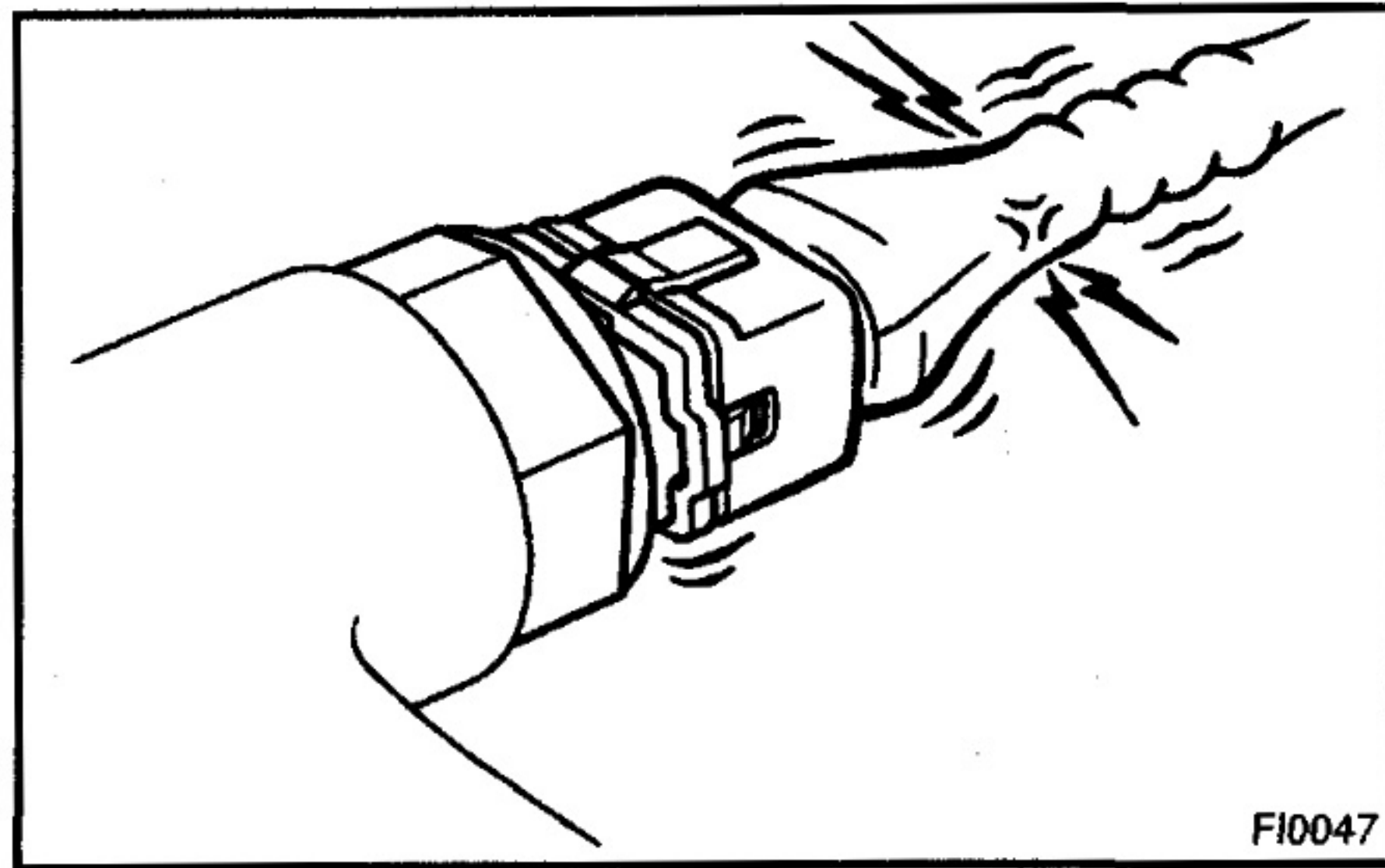

FI0047

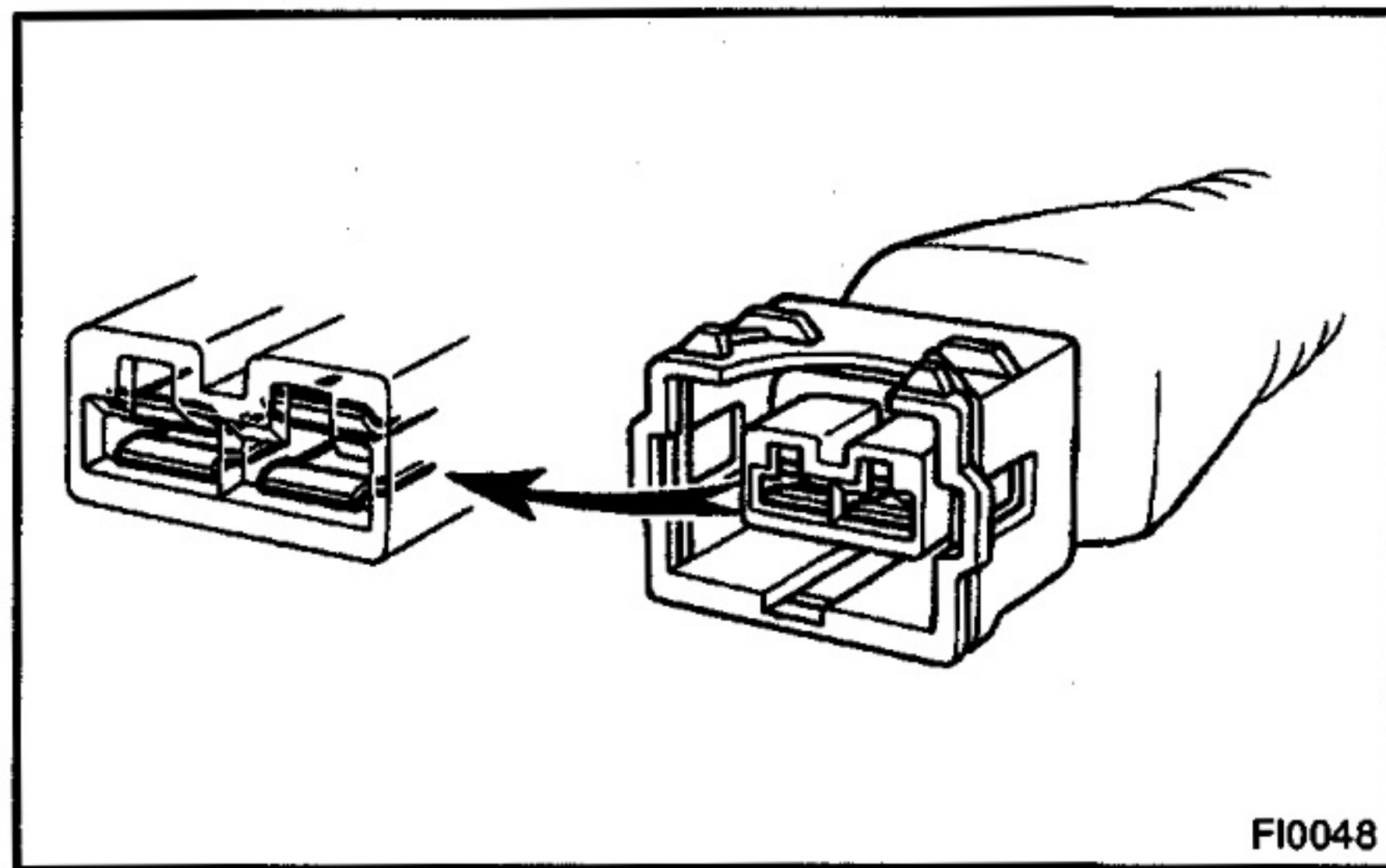

FI0048

HOW TO USE THE DIAGNOSTIC CHART AND INSPECTION PROCEDURE

1. CONNECTOR CONNECTION AND TERMINAL INSPECTION

- For troubleshooting, diagnostic trouble code charts or problem symptom charts are provided for each circuit with detailed inspection procedures on the following pages.
- When all the component parts, wire harnesses and connectors of each circuit except the ECU are found to be normal in troubleshooting, then it is determined that the problem is in the ECU. Accordingly, if diagnosis is performed without the problem symptoms occurring, refer to Step 8 to replace the ECU. So always confirm that the problem symptoms are occurring, or proceed with inspection while using the symptom simulation method.
- The instructions "Check wire harness and connector" and "Check and replace ECU" which appear in the inspection procedure, are common and applicable to all diagnostic trouble codes. Follow the procedure outlined below whenever these instructions appear.

OPEN CIRCUIT:

This could be due to a disconnected wire harness, faulty contact in the connector, a connector terminal pulled out, etc.

HINT:

- It is rarely the case that a wire is broken in the middle of it. Most cases occur at the connector. In particular, carefully check the connectors of sensors and actuators.
- Faulty contact could be due to rusting of the connector terminals, to foreign materials entering terminals or a drop in contact pressure between the male and female terminals of the connector. Simply disconnecting and reconnecting the connectors once changes the condition of the connection and may result in a return to normal operation. Therefore, in troubleshooting, if no abnormality is found in the wire harness and connector check, but the problem disappears after the check, then the cause is considered to be in the wire harness or connectors.

SHORT CIRCUIT:

This could be due to a short circuit between the wire harness and the body ground or to a short circuit occurred inside the switch etc.

HINT:

When there is a short between the wire harness and body ground, check thoroughly whether the wire harness is caught in the body or is clamped properly.

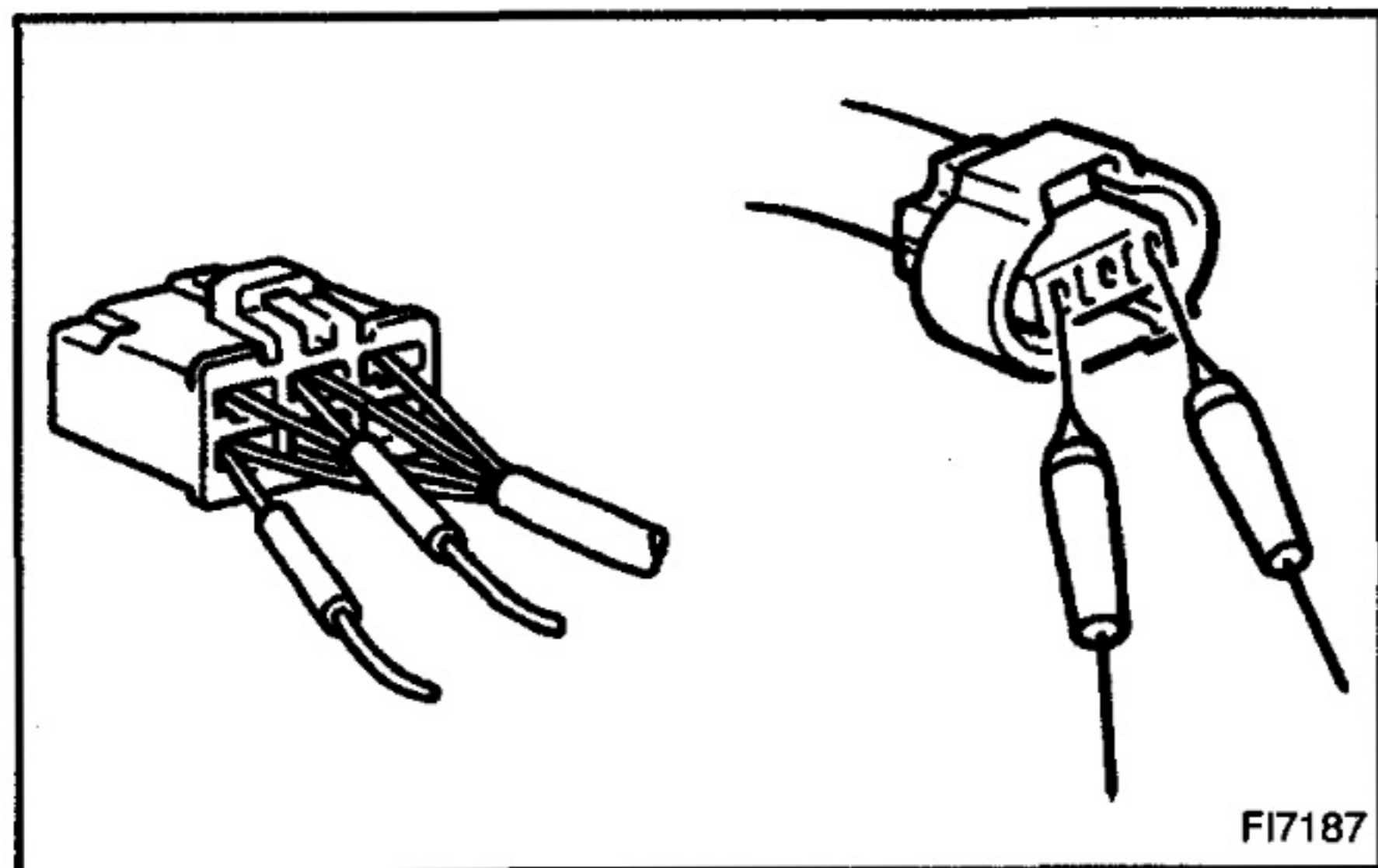

2. CONNECTOR HANDLING

When inserting tester probes into a connector, insert them from the rear of the connector. When necessary, use mini test leads. For water resistant connectors which cannot be accessed from behind, take good care not to deform the connector terminals.

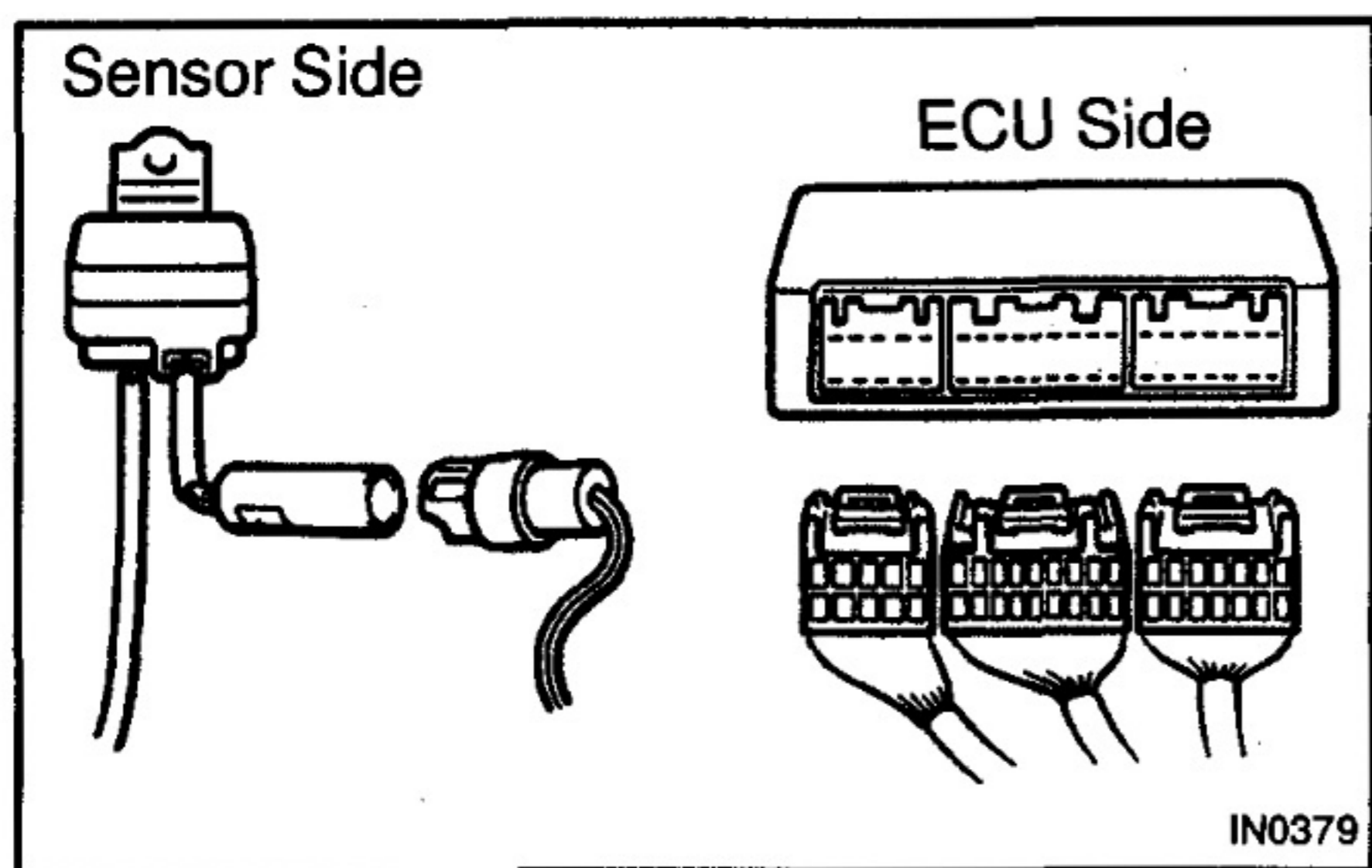

3. CONTINUITY CHECK (OPEN CIRCUIT CHECK)

(a) Disconnect the connectors at both ECU and sensor sides.

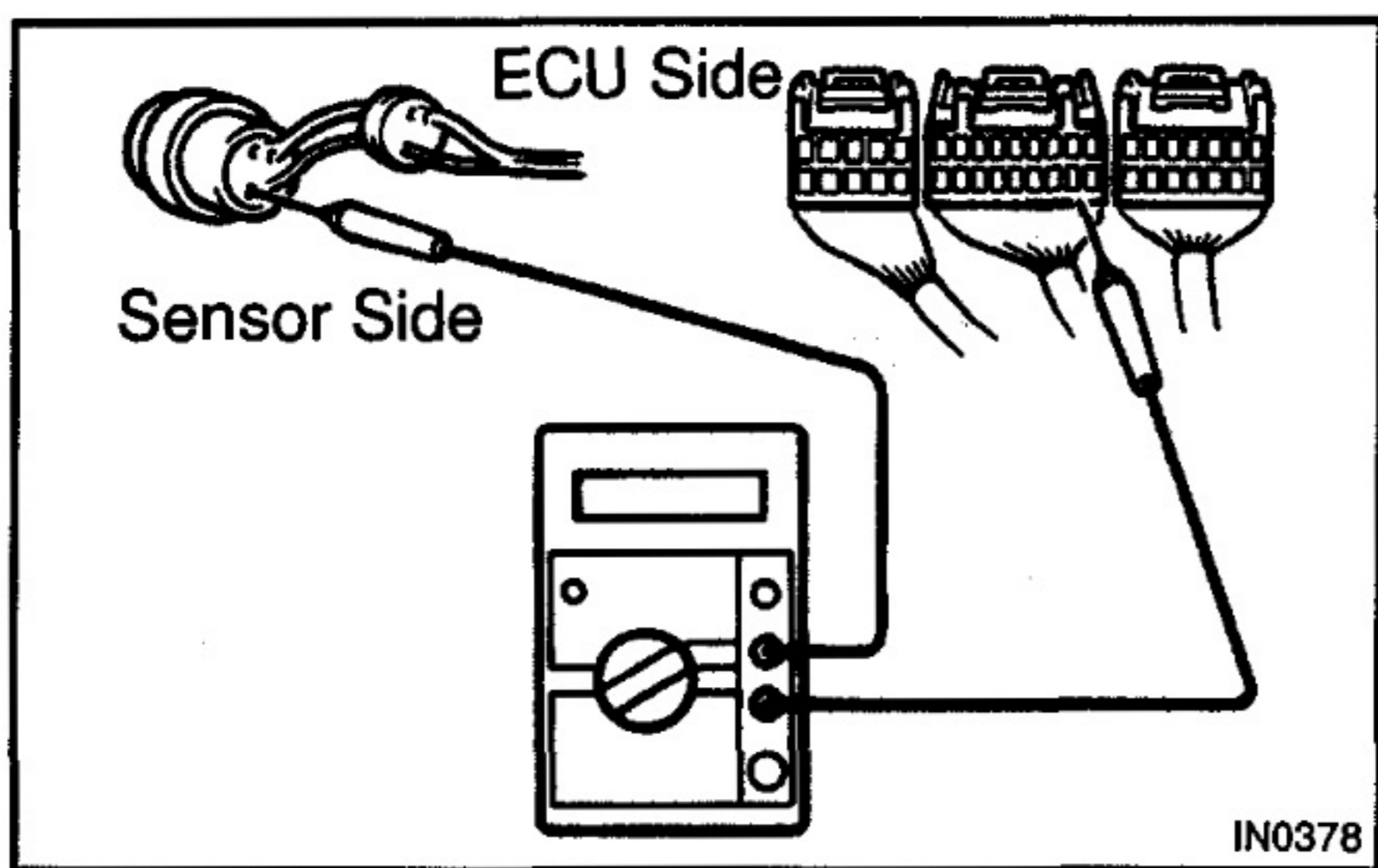

(b) Measure the resistance between the applicable terminals of the connectors.

Resistance: 1 Ω or less

HINT:

Measure the resistance while lightly shaking the wire harness vertically and horizontally.

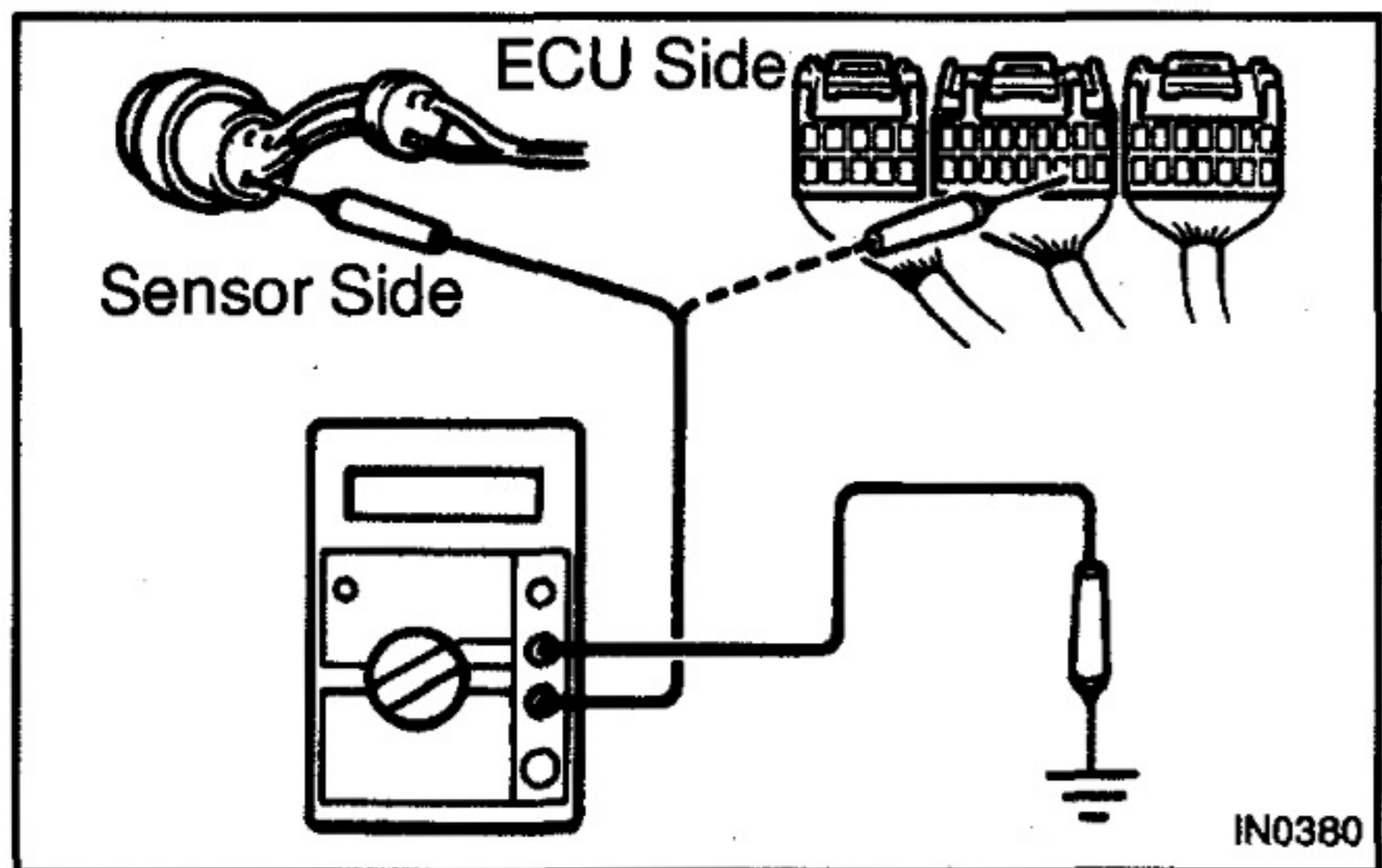

4. RESISTANCE CHECK (SHORT CIRCUIT CHECK)

(a) Disconnect the connectors at both ends.
 (b) Measure the resistance between the applicable terminals of the connectors and body ground. Be sure to carry out this check on the connectors on both ends.

Resistance: 1 MΩ or higher

HINT:

Measure the resistance while lightly shaking the wire harness vertically and horizontally.

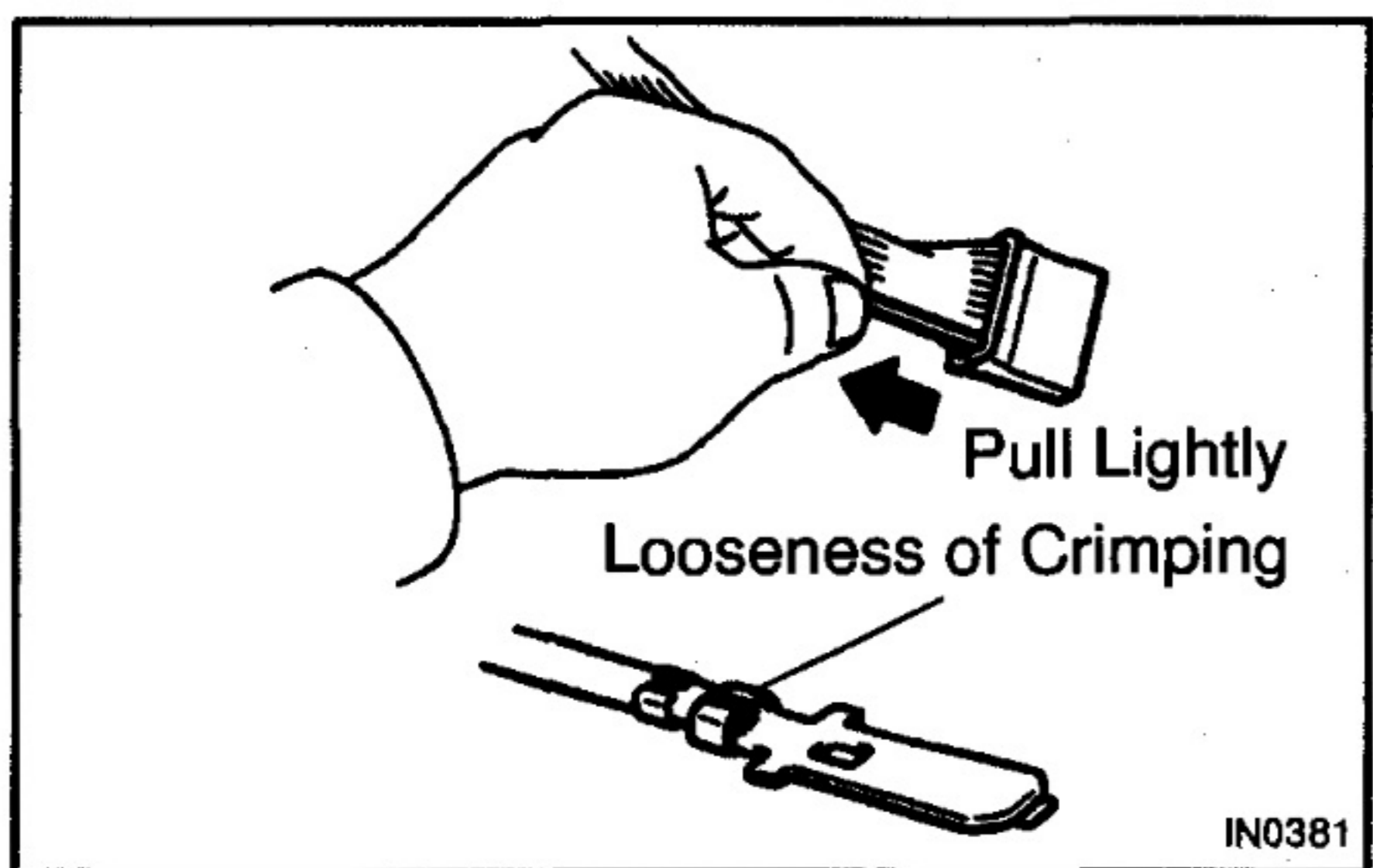

5. VISUAL CHECK AND CONTACT PRESSURE CHECK

(a) Disconnect the connectors at both ends.
 (b) Check for rust or foreign material, etc. in the terminals of the connectors.
 (c) Check crimped portions for looseness or damage and check if the terminals are secured in lock portion.

HINT:

The terminals should not come out when pulled lightly from the back.

- (d) Prepare a test male terminal and insert it in the female terminal, then pull it out.

NOTICE:

When testing a gold-plated female terminal, always use a gold-plated male terminal.

HINT:

When the test terminal is pulled out more easily than others, there may be poor contact in that section.

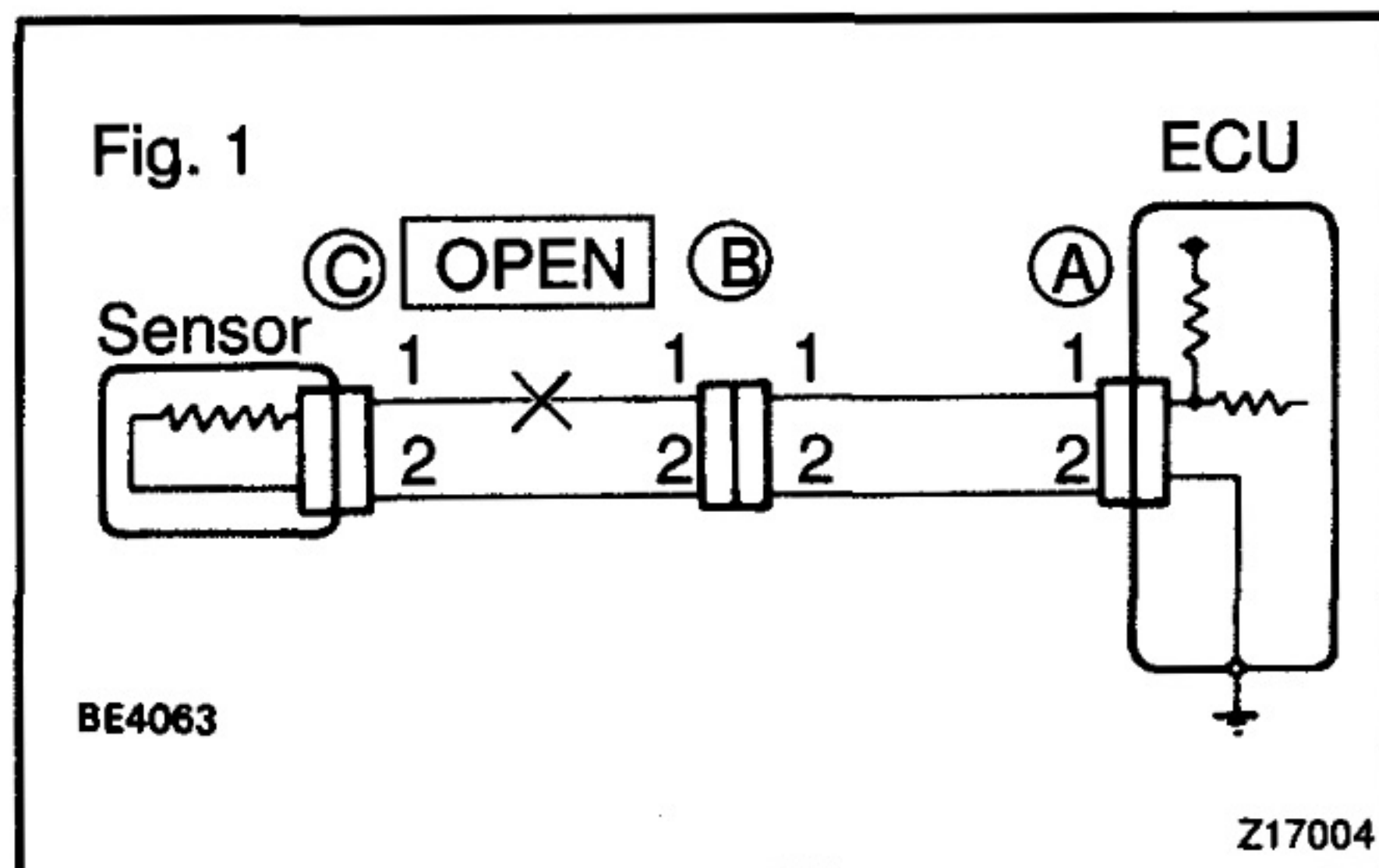

6. CHECK OPEN CIRCUIT

For the open circuit in the wire harness in Fig. 1, perform "(a) Continuity Check" or "(b) Voltage Check" to locate the section.

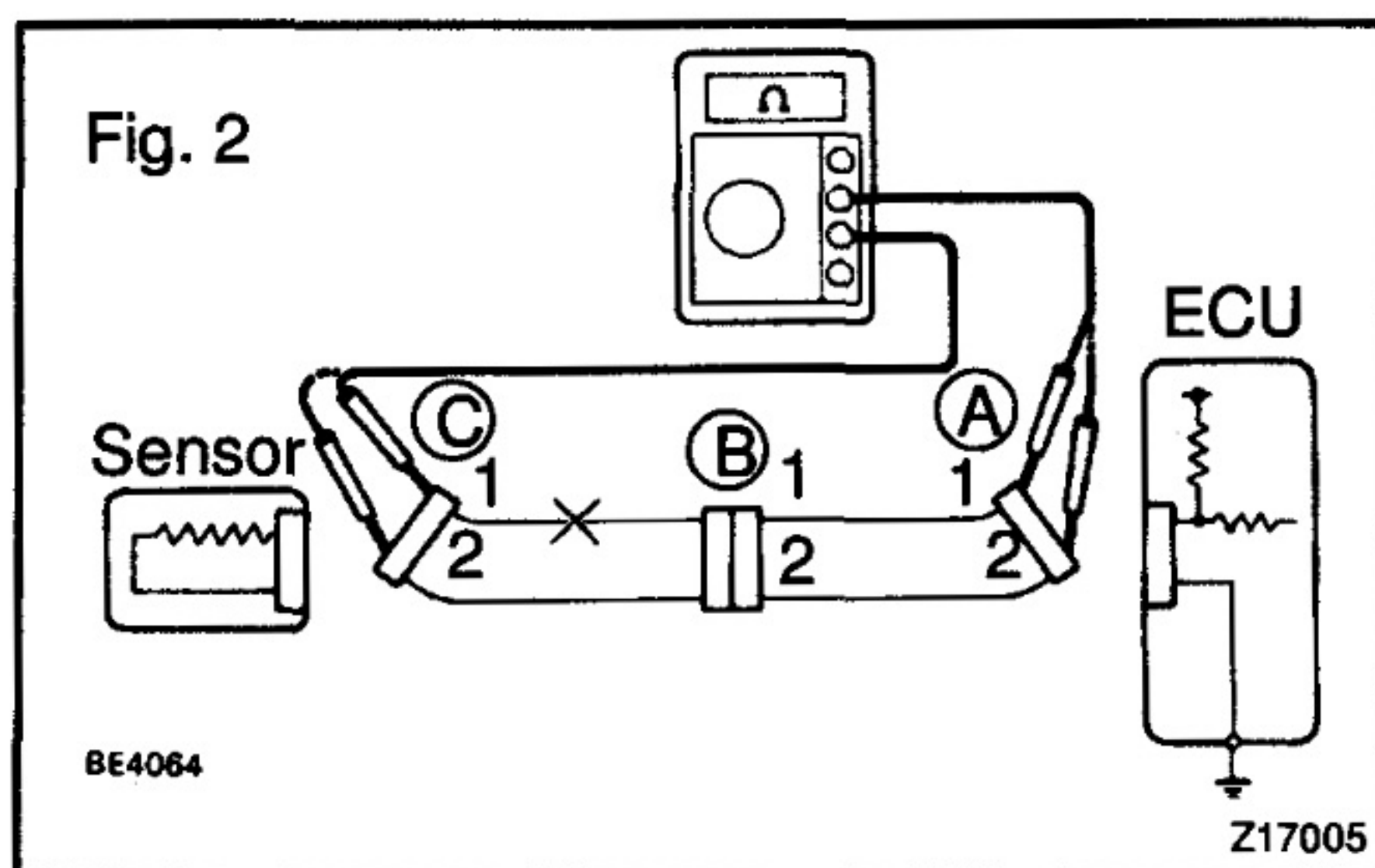

- (a) Check the continuity.

- (1) Disconnect connectors "A" and "C" and measure the resistance between them.

In the case of Fig. 2:

Between terminal 1 of connector "A" and terminal 1 of connector "C" → No continuity (open)

Between terminal 2 of connector "A" and terminal 2 of connector "C" → Continuity

Therefore, it is found out that there is an open circuit between terminal 1 of connector "A" and terminal 1 of connector "C".

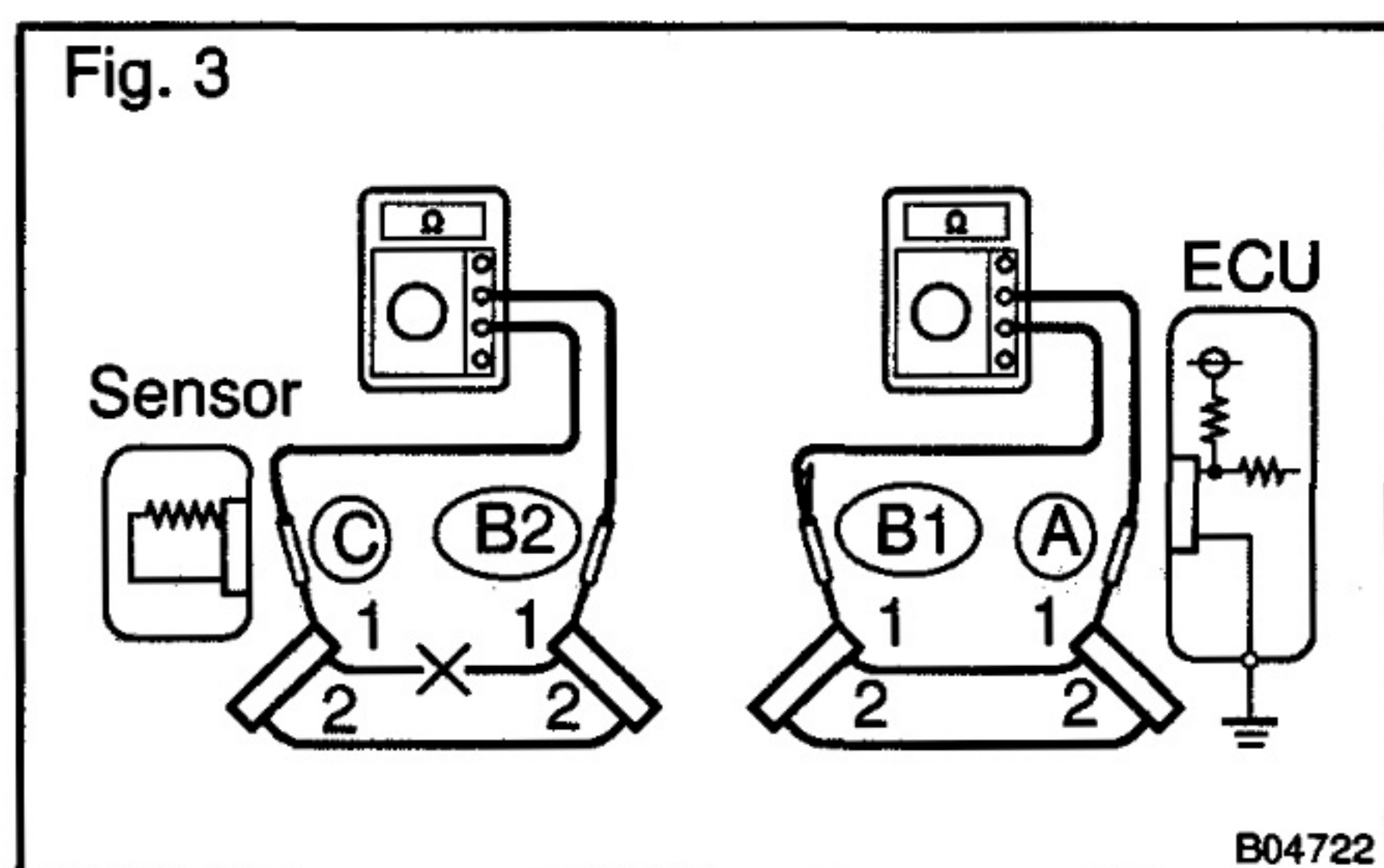

- (2) Disconnect connector "B" and measure the resistance between the connectors.

In the case of Fig. 3:

Between terminal 1 of connector "A" and terminal 1 of connector "B1" → Continuity

Between terminal 1 of connector "B2" and terminal 1 of connector "C" → No continuity (open)

Therefore, it is found out that there is an open circuit between terminal 1 of connector "B2" and terminal 1 of connector "C".

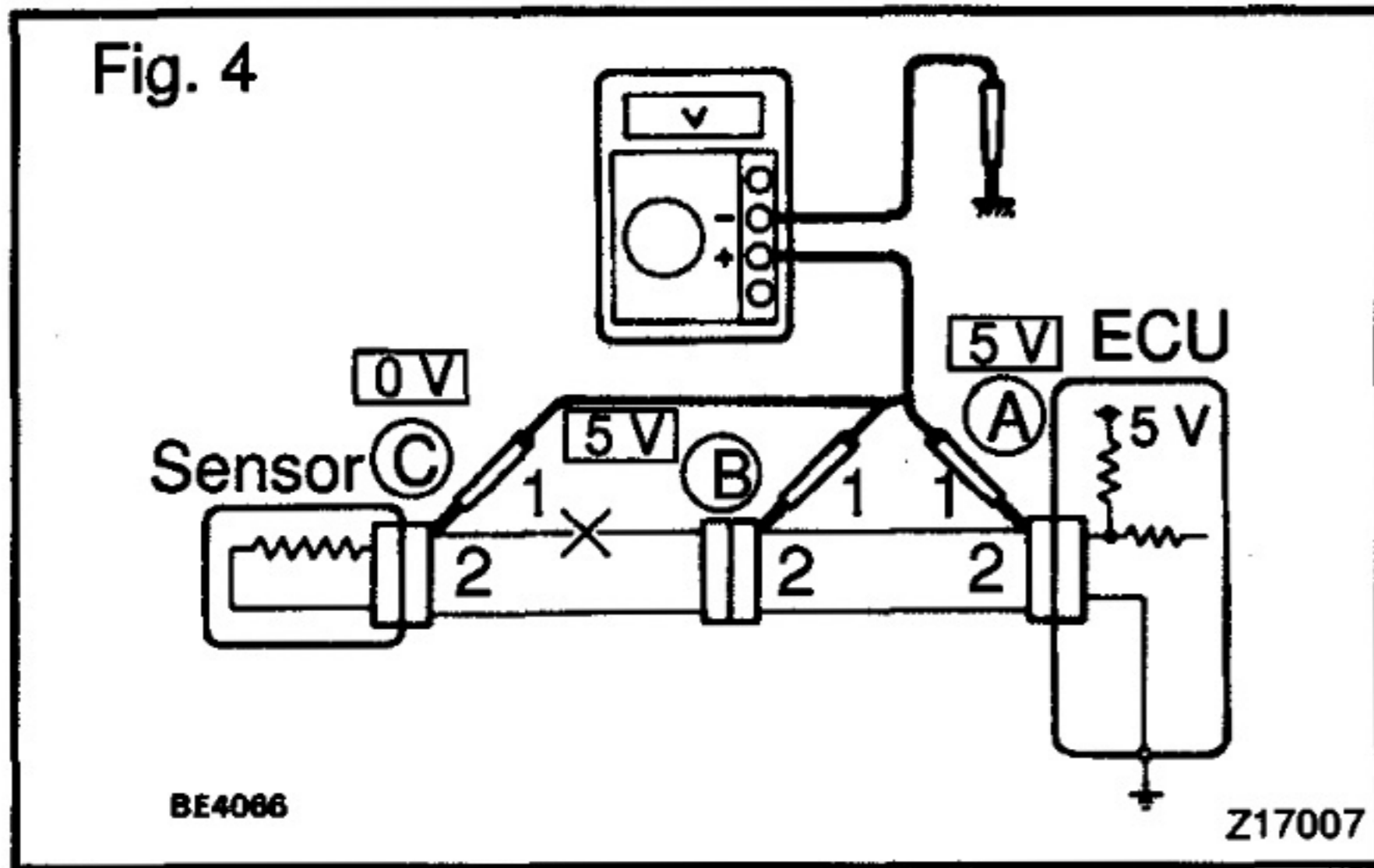

(b) Check the voltage.
 In a circuit in which voltage is applied (to the ECU connector terminal), an open circuit can be checked for by conducting a voltage check.
 As shown in Fig. 4, with each connector still connected, measure the voltage between body ground and terminal 1 of connector "A" at the ECU 5 V output terminal, terminal 1 of connector "B", and terminal 1 of connector "C", in that order.

If the results are:

- 5 V: Between Terminal 1 of connector "A" and Body Ground
 - 5 V: Between Terminal 1 of connector "B" and Body Ground
 - 0 V: Between Terminal 1 of connector "C" and Body Ground
- Then it is found out that there is an open circuit in the wire harness between terminal 1 of "B" and terminal 1 of "C".

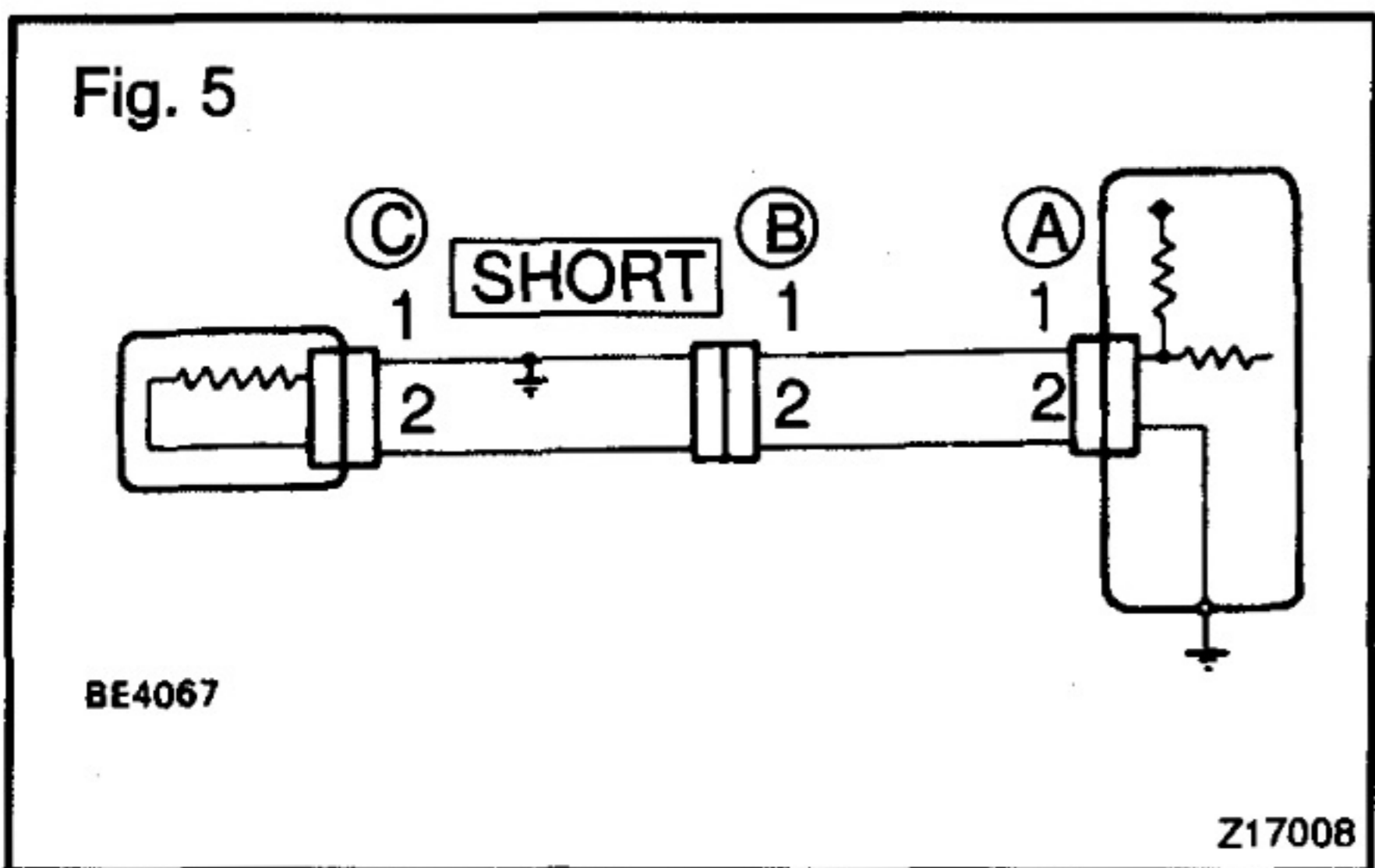

7. CHECK SHORT CIRCUIT

If the wire harness is ground shorted as in Fig. 5, locate the section by conducting a "continuity check with ground".

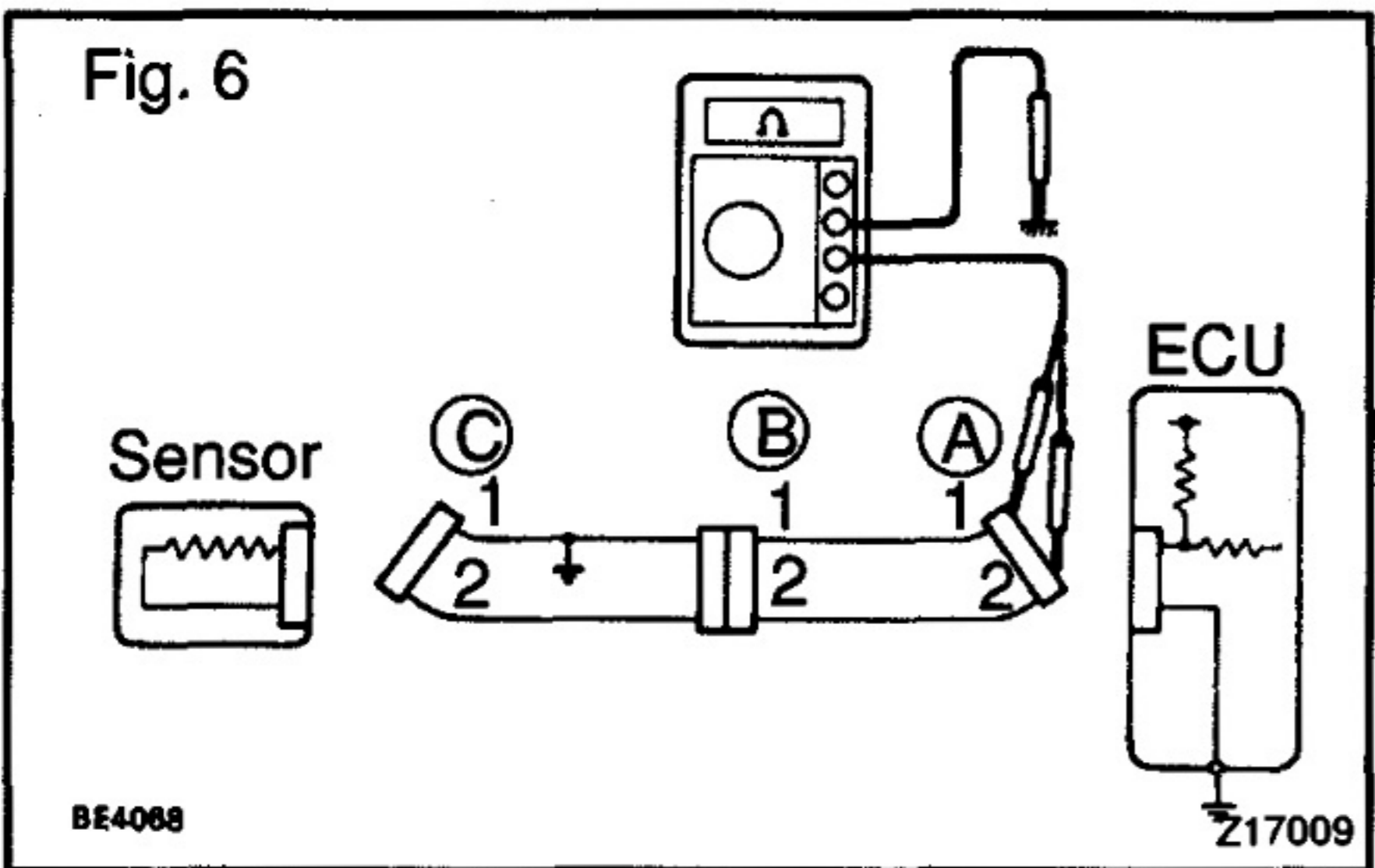

Check the continuity with ground.

- (1) Disconnect connectors "A" and "C" and measure the resistance between terminal 1 and 2 of connector "A" and body ground.

In the case of Fig. 6:

- Between terminal 1 of connector "A" and body ground → Continuity (short)
- Between terminal 2 of connector "A" and body ground → No continuity

Therefore, it is found out that there is a short circuit between terminal 1 of connector "A" and terminal 1 of connector "C".

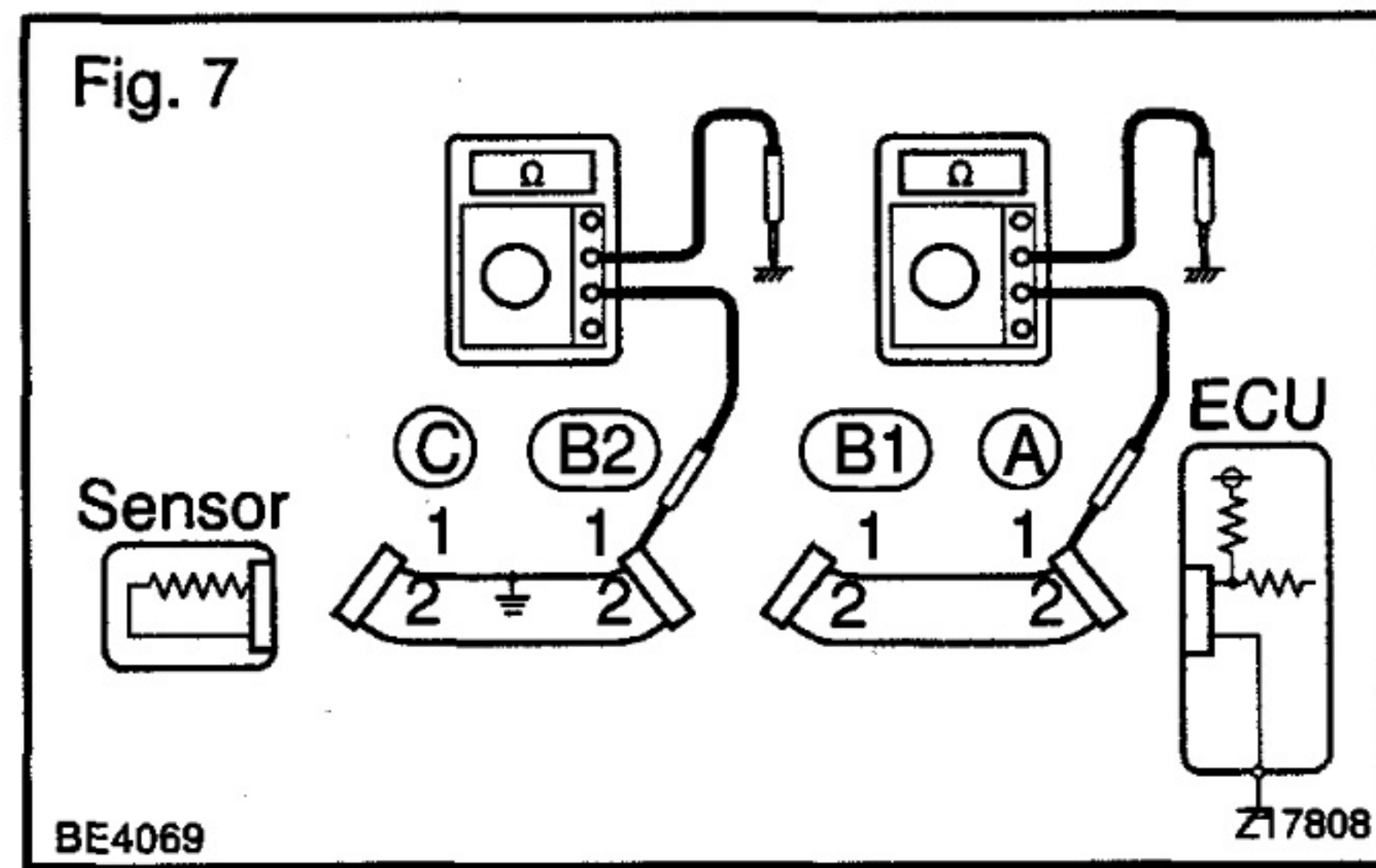

- (2) Disconnect connector "B" and measure the resistance between terminal 1 of connector "A" and body ground, and terminal 1 of connector "B2" and body ground.

In the case of Fig. 7:

Between terminal 1 of connector "A" and body ground → No continuity

Between terminal 1 of connector "B2" and body ground → Continuity (short)

therefore, it is found out that there is a short circuit between terminal 1 of connector "B2" and terminal 1 of connector "C".

8. CHECK AND REPLACE ECU

First check the ECU ground circuit. If it is faulty, repair it. If it is normal, the ECU could be faulty, so replace the ECU with a normal good one and check that the symptoms appear.

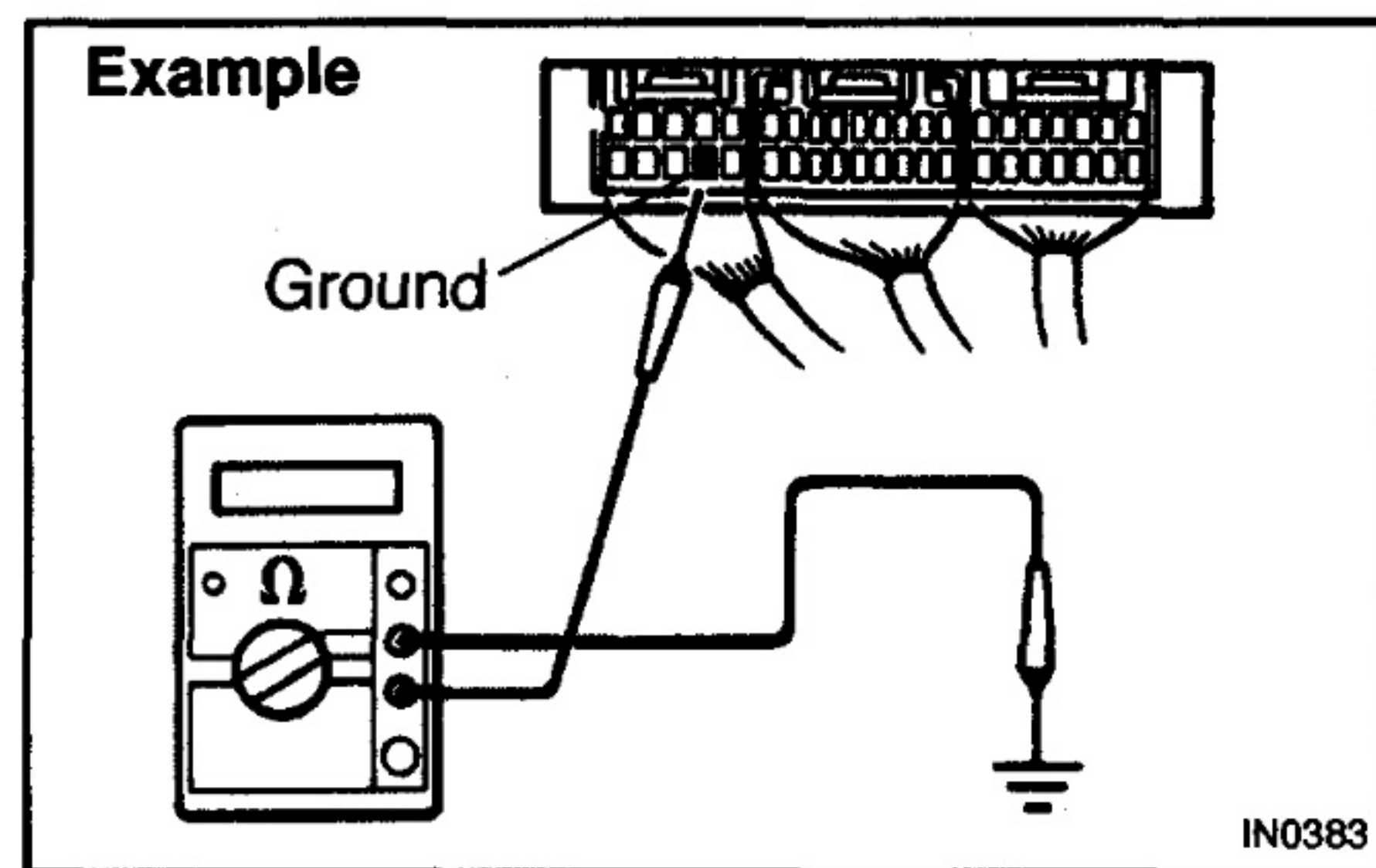

- (1) Measure the resistance between the ECU ground terminal and the body ground.

Resistance: 1 Ω or less

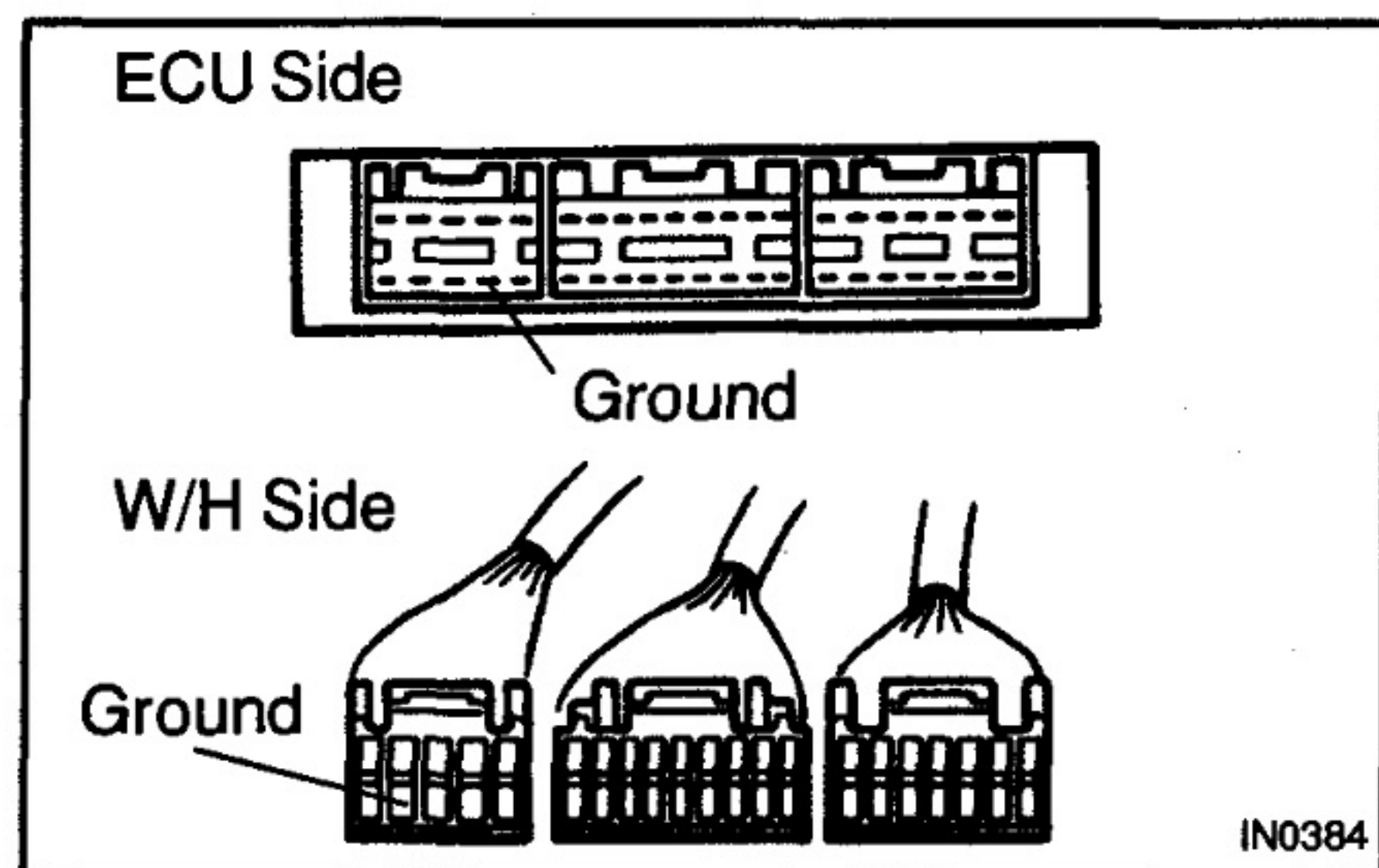

- (2) Disconnect the ECU connector, check the ground terminals on the ECU side and the wire harness side for bend and check the contact pressure.

TERMS**ABBREVIATIONS USED IN THIS MANUAL**

IN00S-13

Abbreviations	Meaning
A/C	Air Conditioning
AC	Alternating Current
ACC	Accessory
ACIS	Acoustic Control Induction System
ACSD	Automatic Cold Start Device
ALT	Alternator
AMP	Amplifier
APPROX.	Approximately
A/T	Automatic Transmission (Transaxle)
BACS	Boost Altitude Compensation System
BAT	Battery
BTDC	Before Top Dead Center
BVSV	Bimetallic Vacuum Switching Valve
CB	Circuit Breaker
CCO	Catalytic Converter for Oxidation
DC	Direct Current
DLC	Data Link Connector
DTC	Diagnostic Trouble Code
ECD	Electronic Control Diesel
ECT	Electronic Control Transmission
ECU	Electronic Control Unit
EDU	Electronic Driving Unit
EFI	Electronic Fuel Injection
E/G	Engine
EGR	Exhaust Gas Recirculation
EVAP	Evaporative Emission Control
E-VRV	Electronic Vacuum Regulating Valve
EX	Exhaust
FIPG	Formed In Place Gasket
FL	Fusible Link
Fr	Front
GND	Ground
HAC	High Altitude Compensator
IG	Ignition
I/A	Integrated Ignition Assembly
IN	Intake
ISC	Idle Speed Control
J/B	Junction Block
J/C	Junction Connector
LCD	Liquid Crystal Display
LED	Light Emitting Diode
LH	Left-Hand

LHD	Left-Hand Drive
LO	Low
MAP	Manifold Absolute Pressure
MAX.	Maximum
MIL	Malfunction Indicator Lamp
MIN.	Minimum
MP	Multipurpose
M/T	Manual Transmission
N	Neutral
O2S	Oxygen Sensor
O/D	Overdrive
O/S	Oversize
PKB	Parking Brake
PS	Power Steering
RAM	Random Access Memory
R/B	Relay Block
RH	Right-Hand
RHD	Right-Hand Drive
ROM	Read Only Memory
Rr	Rear
SICS	Starting Injection Control System
SPEC	Specification
SSM	Special Service Materials
SST	Special Service Tools
STD	Standard
SW	Switch
TACH	Tachometer
TDC	Top Dead Center
TEMP.	Temperature
TM	Transmission
TMC	TOYOTA Motor Corporation
TWC	Three-Way Catalyst
U/D	Underdrive
VCV	Vacuum Control Valve
VIN	Vehicle Identification Number
VSV	Vacuum Switching Valve
w/	With
W/H	Wire Harness
w/o	Without
WU-TWC	Warm Up Three-Way Catalytic Converter
2WD	Two Wheel Drive Vehicle (4x2)
4WD	Four Wheel Drive Vehicle (4x4)

PREPARATION

ENGINE MECHANICAL	PP-1
TURBOCHARGING	PP-3
EMISSION CONTROL	PP-6
ELECTRONIC CONTROL DIESEL	PP-8
ENGINE FUEL	PP-11
COOLING	PP-14
LUBRICATION	PP-15

PP

REFER TO FOLLOWING REPAIR MANUALS:

Manual Name	Pub. No.
1KZ-T Engine Repair Manual	RM353E
1KZ-TE Engine Repair Manual	RM710E
1KZ-T, 1KZ-TE Engine Repair Manual Supplement	RM522E

NOTE: The above pages contain only the points which differ from the above listed manuals.

ENGINE MECHANICAL

SST (Special Service Tools)

PP3F2-01

	09843-18040 Diagnosis Check Wire No.2	
---	---------------------------------------	--

EQUIPMENT



Carbide cutter	
Connecting rod aligner	
Cylinder gauge	
Dial indicator	
Dye penetrant	
Engine tune-up tester	
Micrometer	
Piston ring compressor	
Piston ring expander	
Plastigage	
Tachometer	
Thermometer	
Torque wrench	
Valve seat cutter	
Vernier calipers	

PP

TURBOCHARGING

SST (Special Service Tools)

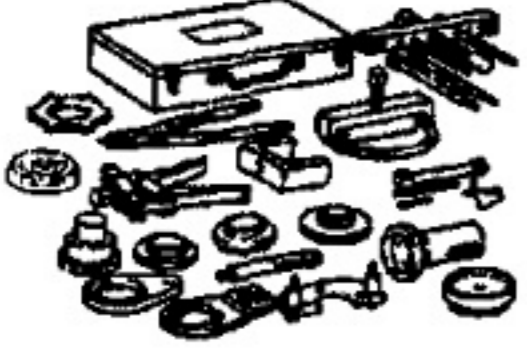
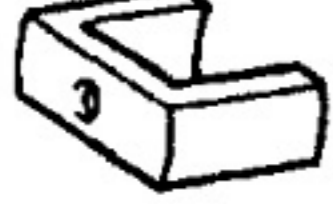
PP3F3-01

	<p>09350-32014 TOYOTA Automatic Transmission Tool Set</p>	
	<p>(09351-32070) No.2 Piston Spring Compressor</p>	<p>Bearing housing</p>
	<p>09992-00242 Turbocharger Pressure Gauge</p>	

PP

RECOMMENDED TOOLS

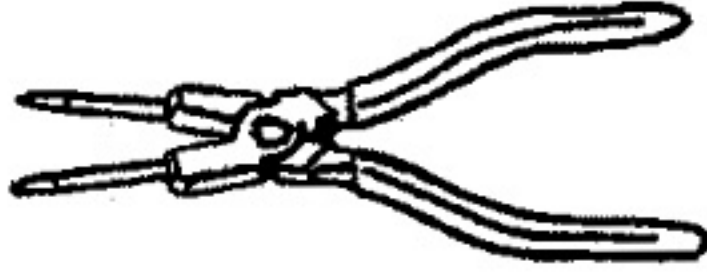
	09905-00013 Snap Ring Pliers .	
---	--------------------------------	--

EQUIPMENT

Dial indicator	Impeller wheel
Torque wrench	

EMISSION CONTROL RECOMMENDED TOOLS

PP15X-02

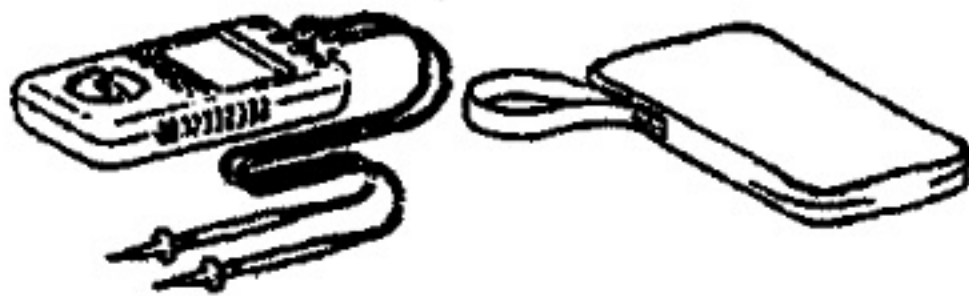
	09082-00040 TOYOTA Electrical Tester.	
---	---------------------------------------	--

EQUIPMENT

MITYVAC (Hand-held vacuum tester)	
Torque wrench	
Vacuum gauge	

ELECTRONIC CONTROL DIESEL

SST (Special Service Tools)

PP1T5-02

	09992-00242 Turbocharger Pressure Gauge	Turbo pressure sensor
---	---	-----------------------

PP

RECOMMENDED TOOLS





	09082-00040 TOYOTA Electrical Tester.	
---	---------------------------------------	--

EQUIPMENT

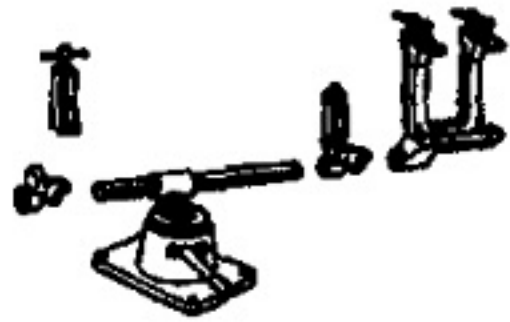

Thermometer	
Torque wrench	
Torx socket (E8)	
Vacuum gauge	
19 mm deep socket wrench	

ENGINE FUEL**SST (Special Service Tools)**

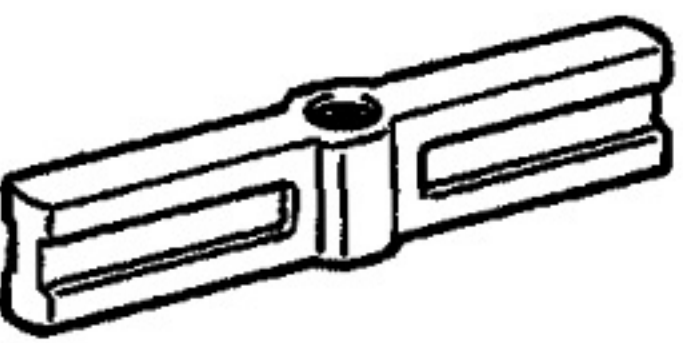
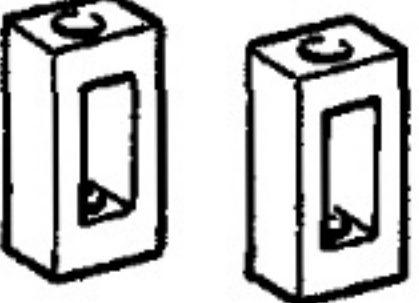
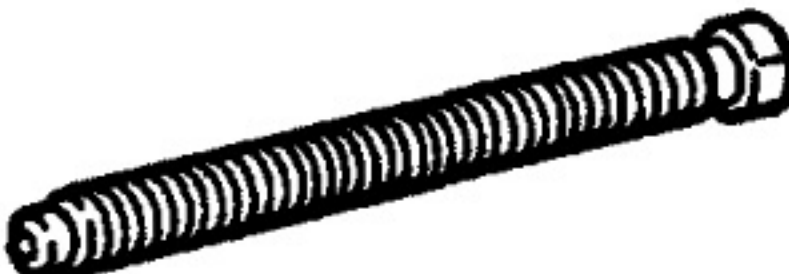
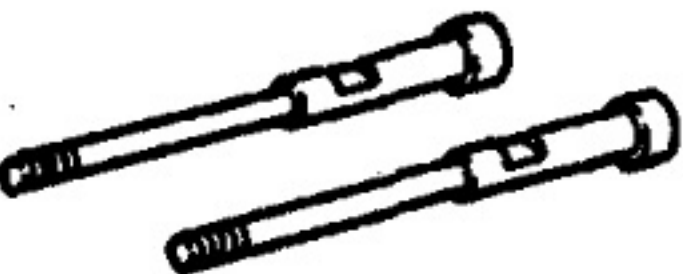
PP3F8-02

	09241-76022	Injection Pump Stand Set	
	09245-54010	Injection Pump Stand Arm	
	09260-54012	Injection Pump Tool Set	
	(09262-54010)	Distributor Head Plug Wrench	
	(09269-54020)	Socket 14 mm	
	(09951-05010)	Hanger 150	
	(09952-05010)	Slide Arm	
	(09953-05020)	Center Bolt 150	
	(09954-05010)	Claw No.1	

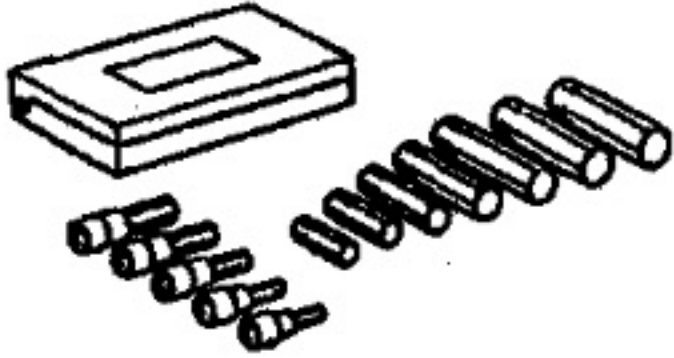
RECOMMENDED TOOLS

	09040-00011 Hexagon Wrench Set .	
	09082-00040 TOYOTA Electrical Tester.	

EQUIPMENT

Injection nozzle tester	
Injection pump tester	
Torque wrench	
19 mm deep socket wrench	Fuel temperature sensor

COOLING

COOLANT

PP1TK-03

Item	Capacity	Classification
Engine coolant 4Runner, Land Cruiser/Land Cruiser Prado		"Toyota Long Life Coolant" or equivalent
M/T w/ Rear heater	10.5 liters (11.1 US qts, 9.2 Imp. qts)	
w/o Rear heater	9.5 liters (10.0 US qts, 8.4 Imp. qts)	
A/T w/ Rear heater	11 liters (11.6 US qts, 9.7 Imp. qts)	
w/o Rear heater	10 liters (10.6 US qts, 8.8 Imp. qts)	
Hilux		
w/ Rear heater	10.5 liters (11.1 US qts, 9.2 Imp. qts)	
w/ Rear heater	9.5 liters (10.0 US qts, 8.4 Imp. qts)	

LUBRICATION

SST (Special Service Tools)

PP3F8-01

	09228-10002 Oil Filter Wrench	
---	-------------------------------	--

LUBRICANT

Item	Capacity	Classification
Engine oil 4Runner, Land Cruiser/Land Cruiser		API grade CF-4 or CF (You may also use API CE or CD)
Prado		
Dry fill	7.5 liters (7.9 US qts, 6.6 Imp. qts)	
Drain and refill	7.0 liters (7.4 US qts, 6.2 Imp. qts)	
w/ Oil filter change	7.0 liters (7.4 US qts, 6.2 Imp. qts)	
w/o Oil filter change	6.4 liters (6.8 US qts, 5.6 Imp. qts)	
Hilux		
Dry fill	7.6 liters (8.0 US qts, 6.7 Imp. qts)	
Drain and refill	7.1 liters (7.5 US qts, 6.2 Imp. qts)	
w/ Oil filter change	7.1 liters (7.5 US qts, 6.2 Imp. qts)	
w/o Oil filter change	6.4 liters (6.8 US qts, 5.6 Imp. qts)	

SERVICE SPECIFICATIONS

STANDARD BOLT	SS-1
ENGINE MECHANICAL	SS-4
TURBOCHARGING	SS-6
EMISSION CONTROL	SS-8
ELECTRONIC CONTROL DIESEL	SS-10
ENGINE FUEL	SS-12
LUBRICATION	SS-14
STARTING	SS-15

SS

REFER TO FOLLOWING REPAIR MANUALS:











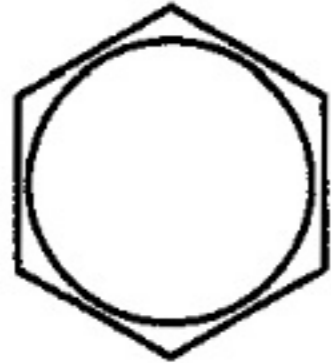

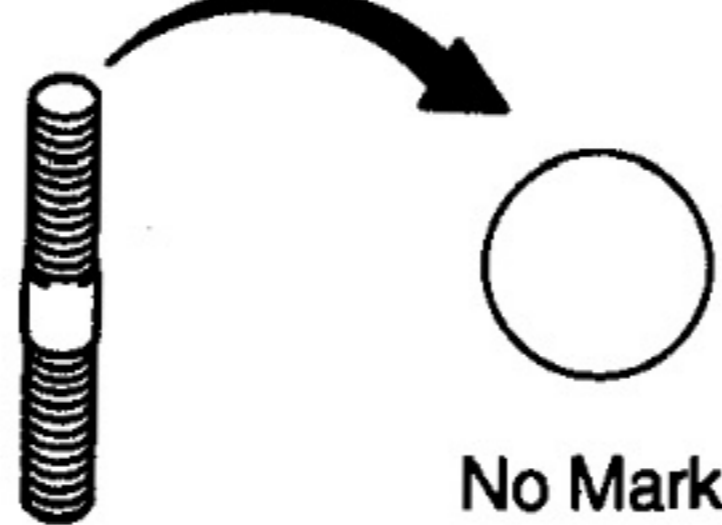
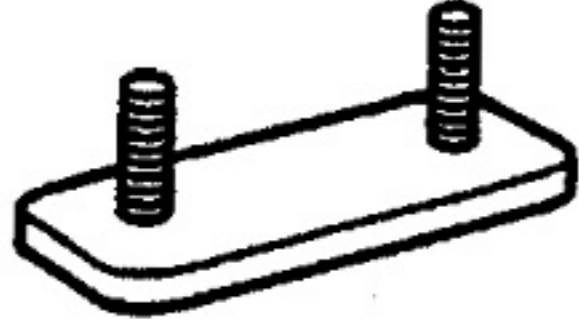

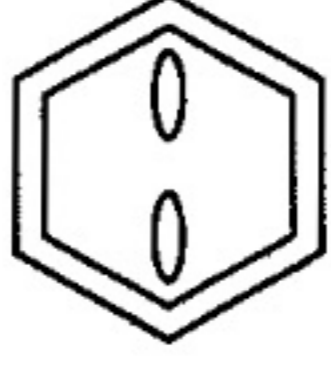

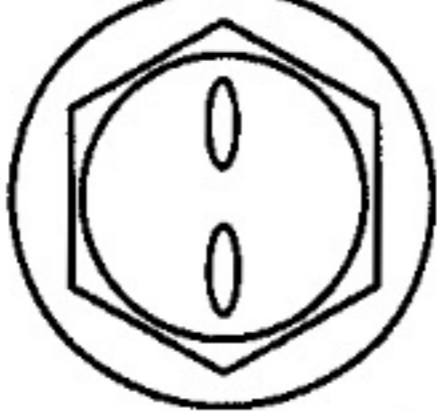







Manual Name	Pub. No.
1KZ-T Engine Repair Manual	RM353E
1KZ-TE Engine Repair Manual	RM710E
1KZ-T, 1KZ-TE Engine Repair Manual Supplement	RM522E

NOTE: The above pages contain only the points which differ from the above listed manuals.

STANDARD BOLT

HOW TO DETERMINE BOLT STRENGTH

SS028-01

Bolt Type			Class	
Hexagon Head Bolt		Stud Bolt		Weld Bolt
Normal Recess Bolt	Deep Recess Bolt			
  No Mark	 No Mark	 No Mark	 4T	
 			5T	
  w/ Washer	 w/ Washer		6T	
 	 		7T	
		 	8T	
			9T	
	 		10T	
	 		11T	









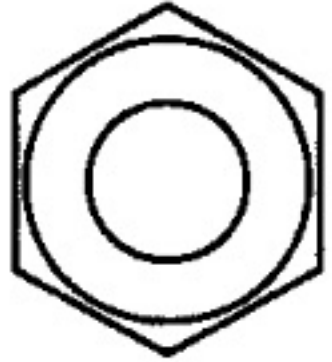
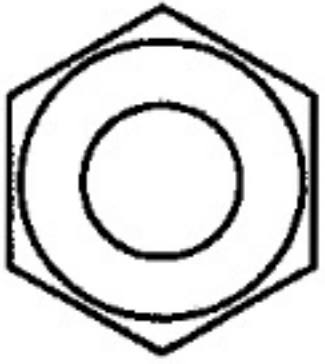
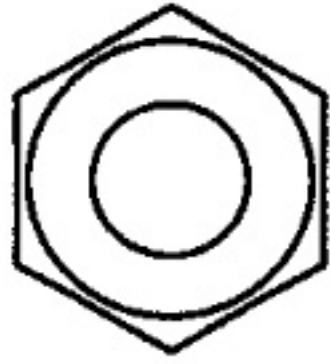
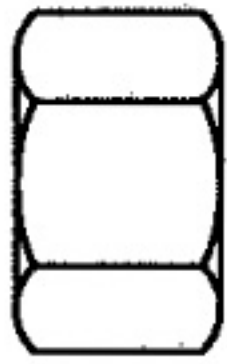

SS

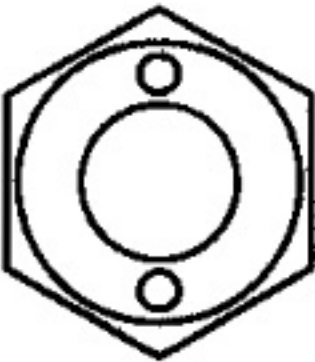
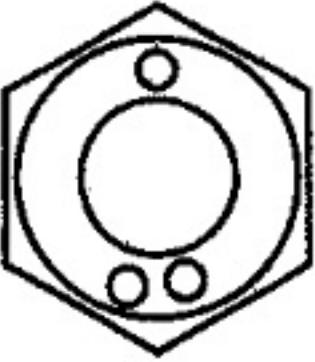
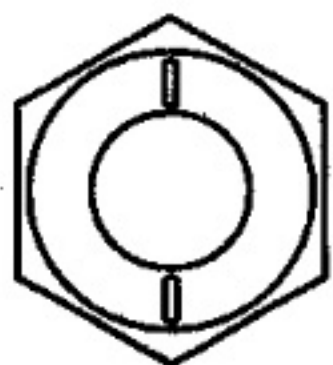
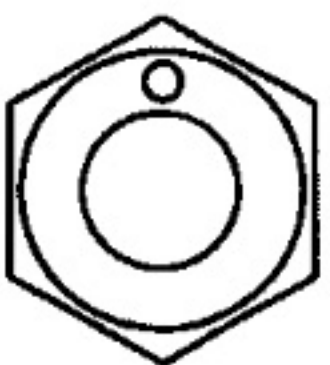
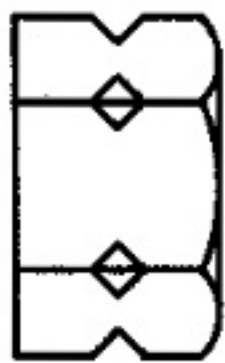
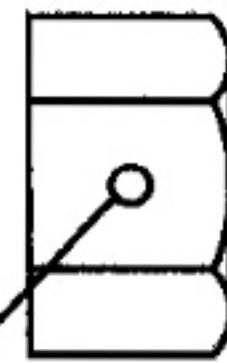
SPECIFIED TORQUE FOR STANDARD BOLTS

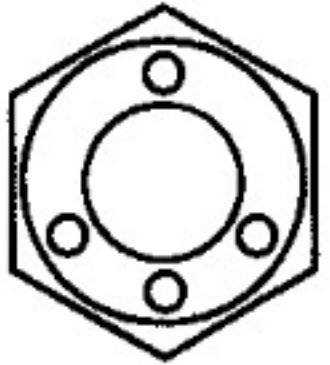
SS

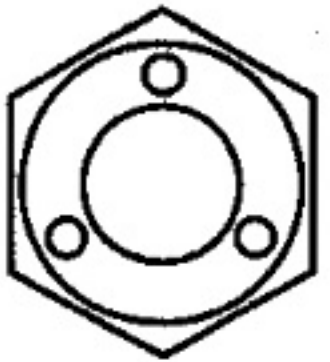
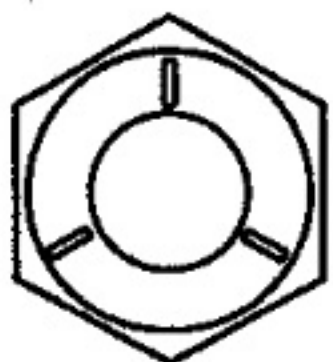
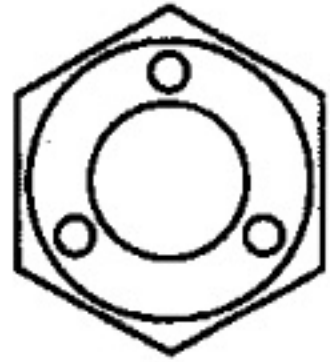
Class	Diameter mm	Pitch mm	Specified torque					
			Hexagon head bolt			Hexagon flange bolt		
			N·m	kgf·cm	ft·lbf	N·m	kgf·cm	ft·lbf
4T	6	1	5	55	48 in·lbf	6	60	52 in·lbf
	8	1.25	12.5	130	9	14	145	10
	10	1.25	26	260	19	29	290	21
	12	1.25	47	480	35	53	540	39
	14	1.5	74	760	55	84	850	61
	16	1.5	115	1,150	83	–	–	–
5T	6	1	6.5	65	56 in·lbf	7.5	75	65 in·lbf
	8	1.25	15.5	160	12	17.5	175	13
	10	1.25	32	330	24	36	360	26
	12	1.25	59	600	43	65	670	48
	14	1.5	91	930	67	100	1,050	76
	16	1.5	140	1,400	101	–	–	–
6T	6	1	8	80	69 in·lbf	9	90	78 in·lbf
	8	1.25	19	195	14	21	210	15
	10	1.25	39	400	29	44	440	32
	12	1.25	71	730	53	80	810	59
	14	1.5	110	1,100	80	125	1,250	90
	16	1.5	170	1,750	127	–	–	–
7T	6	1	10.5	110	8	12	120	9
	8	1.25	25	260	19	28	290	21
	10	1.25	52	530	38	58	590	43
	12	1.25	95	970	70	105	1,050	76
	14	1.5	145	1,500	108	165	1,700	123
	16	1.5	230	2,300	166	–	–	–
8T	8	1.25	29	300	22	33	330	24
	10	1.25	61	620	45	68	690	50
	12	1.25	110	1,100	80	120	1,250	90
9T	8	1.25	34	340	25	37	380	27
	10	1.25	70	710	51	78	790	57
	12	1.25	125	1,300	94	140	1,450	105
10T	8	1.25	38	390	28	42	430	31
	10	1.25	78	800	58	88	890	64
	12	1.25	140	1,450	105	155	1,600	116
11T	8	1.25	42	430	31	47	480	35
	10	1.25	87	890	64	97	990	72
	12	1.25	155	1,600	116	175	1,800	130

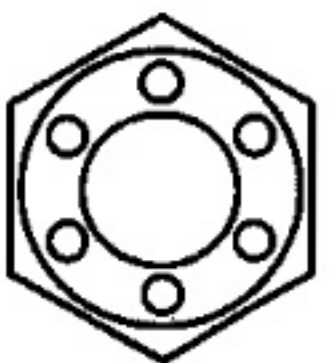
HOW TO DETERMINE NUT STRENGTH

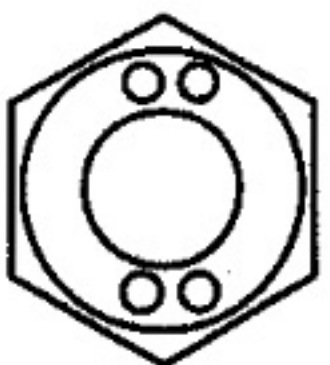
Nut Type		Class	
Present Standard Hexagon Nut	Old Standard Hexagon Nut		
		Cold Forging Nut	Cutting Processed Nut
 No Mark			4N
 No Mark (w/ Washer)	 No Mark (w/ Washer)	 No Mark	5N (4T)
  			6N
	 	 	7N (5T)
 			8N
 	 	 No Mark	10N (7T)
 			11N
 			12N

*: Nut with 1 or more marks on one side surface of the nut.

B06432

HINT:

Use the nut with the same number of the nut strength classification or the greater than the bolt strength classification number when tightening parts with a bolt and nut.

Example: Bolt = 4T

Nut = 4N or more

SS

ENGINE MECHANICAL

SERVICE DATA

SS02E-04

Idle speed		650 - 750 rpm
Maximum speed		4,450 - 4,750 rpm
Cylinder head	Valve seat Refacing angle	Intake 30° 45° 60° Exhaust 30° 45° 60°
	Contacting angle	45°
	Contacting width	Intake 1.5 - 1.9 mm (0.059 - 0.075 in.)
		Exhaust 1.8 - 2.2 mm (0.071 - 0.087 in.)
Valve	Valve face angle	44.5°
	Margin thickness	STD Intake 1.6 mm (0.063 in.)
		Exhaust 1.7 mm (0.067 in.)
		Minimum Intake 1.1 mm (0.043 in.)
	Overall length	Exhaust 1.2 mm (0.047 in.)
STD 103.29 - 103.69 mm (4.0665 - 4.08323 in.)		
Cylinder block	Cylinder bore diameter	STD Mark 1 96.000 - 96.010 mm (3.7795 - 3.7799 in.)
		Mark 2 96.010 - 96.020 mm (3.7799 - 3.7803 in.)
		Mark 3 96.020 - 96.030 mm (3.7803 - 3.7807 in.)
		Maximum 96.23 mm (3.7886 in.)
	Main journal bore diameter	STD Mark 1 75.000 - 75.006 mm (2.9528 - 2.9530 in.)
		Mark 2 75.006 - 75.012 mm (2.9530 - 2.9532 in.)
Piston and piston ring	Piston diameter	STD Mark 1 95.940 - 95.950 mm (3.7772 - 3.7776 in.)
		Mark 2 95.950 - 95.960 mm (3.7776 - 3.7779 in.)
		Mark 3 95.960 - 95.970 mm (3.7779 - 3.7783 in.)
		O/S 0.50 96.440 - 96.470 mm (3.7968 - 3.7980 in.)
		O/S 0.75 96.690 - 96.720 mm (3.8067 - 3.8079 in.)
		O/S 1.00 96.940 - 96.970 mm (3.8165 - 3.8177 in.)
	Piston oil clearance	STD 0.050 - 0.070 mm (0.0020 - 0.0028 in.)
		Maximum 0.14 mm (0.0055 in.)
	Piston ring groove clearance	No. 1 0.060 - 0.110 mm (0.0024 - 0.0043 in.)
		No. 2 0.060 - 0.100 mm (0.0024 - 0.0039 in.)
		Oil 0.020 - 0.060 mm (0.0009 - 0.0024 in.)
	Piston ring end gap	STD No. 1 0.350 - 0.570 mm (0.0138 - 0.0224 in.)
		No. 2 0.400 - 0.600 mm (0.0157 - 0.0236 in.)
		Oil 0.200 - 0.500 mm (0.0079 - 0.0197 in.)
		Limit No.1 1.03 mm (0.0406 in.)
No. 2 1.10 mm (0.0433 in.)		
Oil 0.87 mm (0.0343 in.)		
Crankshaft	Main journal oil clearance	STD 0.036 - 0.054 mm (0.0014 - 0.0021 in.)
		Maximum 0.10 mm (0.0039 in.)
	Main journal diameter	STD Mark 1 69.994 - 70.000 mm (2.7557 - 2.7559 in.)
		Mark 2 69.988 - 69.994 mm (2.7554 - 2.7557 in.)
		Mark 3 69.982 - 69.988 mm (2.7552 - 2.7554 in.)
	Main bearing center wall thickness (Reference)	STD Mark 2 2.482 - 2.485 mm (0.0977 - 0.0978 in.)
		Mark 3 2.485 - 2.488 mm (0.0978 - 0.0980 in.)
		Mark 4 2.488 - 2.491 mm (0.0980 - 0.0981 in.)
		Mark 5 2.491 - 2.494 mm (0.0981 - 0.0982 in.)
		Mark 6 2.494 - 2.497 mm (0.0982 - 0.0983 in.)

SS

TORQUE SPECIFICATION

Part tightened		N·m	kgf·cm	ft·lbf
Intercooler x Bracket	w/ Intercooler	12	120	9
Intake air connector x Inter cooler	w/ Intercooler	10	100	7
EGR pipe x Exhaust manifold	w/ EGR	19	190	14
EGR valve x Intake manifold	w/ EGR	20	200	15
Exhaust manifold x Cylinder head		52	530	38
Cylinder head cover x Cylinder head		9	90	80 in·lbf
Intake pipe x Intake manifold		12	120	9
Injection pump x Timing gear case		21	210	15
No. 1 camshaft timing pulley x Camshaft		98	1,000	72
No. 2 camshaft timing pulley x Injection pump drive gear		13	130	10
Idler pulley bolt x Timing gear case		35	350	26
Timing belt tensioner x Timing gear case		13	130	10
Injection pump drive gear x Injection pump		64	650	47
Camshaft oil seal retainer x Cylinder head		9	90	80 in·lbf
Camshaft bearing cap x Cylinder head		18	185	13
Injection nozzle x Cylinder head		54	540	40
Nozzle leakage pipe x Injection nozzle		30	300	22
Water outlet x Cylinder head		16	165	12
Intake manifold x Cylinder head		29	290	21
Oil dipstick guide x Cylinder head		20	200	15
Injection pipe x Injection nozzle		15	150	11
Injection pipe x Injection pump		15	150	11
Main bearing cap x Cylinder block	1st	49	500	36
	2nd	Turn 90°	Turn 90°	Turn 90°
Connection rod cap x Connecting rod	1st	29.5	300	22
	2nd	Turn 90°	Turn 90°	Turn 90°
Front engine hanger x Cylinder head		47	460	35

TURBOCHARGING

SERVICE DATA

SS020-02

Turbocharger	Turbocharging pressure		51 - 67 kPa (0.52 - 0.68 kgf/cm ² , 7.4 - 9.7 psi)
	Turbine shaft axial play	Maximum	0.150 mm (0.0063 in.)
	Turbine shaft radial play	Maximum	0.110 mm (0.0043 in.)
Actuator	Actuator stroke		1.20 - 1.70 mm (0.0472 - 0.0669 in.)

TORQUE SPECIFICATION

Part tightened	N·m	kgf·cm	ft·lbf
V-band x Bearing housing	4.8	49	42 in.·lbf
Actuator x Compressor housing	19.1	195	14
Bearing housing side plate x Bearing housing	12	122	9

EMISSION CONTROL

SERVICE DATA

SS0YM-03

EGR valve lift sensor	Resistance (at 20°C (68°F))		
	Between terminals 1 and 2	at 20°C (68°F)	2.6 Ω
	Between terminals 2 and 3	at fully open	0.6 Ω
		at fully closed	2.2 Ω

TORQUE SPECIFICATION

Part tightened		N·m	kgf·cm	ft·lbf
EGR valve x EGR pipe	w/ EGR	19.6	200	14
EGR pipe x Exhaust manifold	w/ EGR	39.2	400	29
EGR valve x Intake manifold	w/ EGR	20	200	14
E-VRV for EGR	w/ EGR	5.4	55	48 in.·lbf

ELECTRONIC CONTROL DIESEL

SS0L2-04

SERVICE DATA

Throttle control motor	Resistance (2 and 1/3, 5 and 4/3)	at hot at cold	23 – 33 Ω 29 – 39 Ω
Timing control valve	Resistance	at 20°C (68°F)	10 – 14 Ω
Spill control valve	Resistance	at 20°C (68°F)	1 – 2 Ω
E-VRV for EGR (w/ EGR)	Resistance	at 20°C (68°F)	11 – 13 Ω
Water temperature sensor	Resistance	at -20°C (-4°F)	10 – 20 kΩ
Fuel temperature sensor		at 0°C (32°F)	4 – 7 kΩ
Intake air temperature sensor		at 20°C (68°F)	2 – 3 kΩ
		at 40°C (104°F)	0.9 – 1.3 kΩ
		at 60°C (140°F)	0.4 – 0.7 kΩ
		at 80°C (176°F)	0.2 – 0.4 kΩ
Turbo pressure sensor	Power source voltage		4.5 – 5.5 V
Engine speed sensor	Resistance	at 20°C (68°F)	205 – 255 Ω

SS

TORQUE SPECIFICATION

Part tightened	N·m	kgf·cm	ft·lbf
Throttle body x Intake manifold	20	200	15
Fuel temperature sensor x Fuel pump	21.6	220	16
Intake air connector x Intercooler w/ Inter cooler	10	100	7
Intercooler x Bracket w/ Inter cooler	12	120	9
Intake pipe x Intake manifold w/o Inter cooler	12	120	9
E-VRV for EGR x EGR valve w/ EGR	5.4	55	48 in·lbf
Intake air temperature sensor x Intercooler w/ Inter cooler	29.4	300	22

ENGINE FUEL

SERVICE DATA

SS00X-05

Injection nozzle	Nozzle opening pressure	New nozzle	15,298 – 16,083 kPa (156 – 164 kgf/cm ² , 2,219 – 2,333 psi)																																												
		Reused nozzle	14,710 – 15,690 kPa (150 – 160 kgf/cm ² , 2,134 – 2,276 psi)																																												
	Adjusting shim thickness		<table border="0"> <tbody> <tr><td>0.900 mm (0.0354 in.)</td><td>0.925 mm (0.0364 in.)</td></tr> <tr><td>0.950 mm (0.0374 in.)</td><td>0.975 mm (0.0384 in.)</td></tr> <tr><td>1.000 mm (0.0394 in.)</td><td>1.025 mm (0.0404 in.)</td></tr> <tr><td>1.050 mm (0.0413 in.)</td><td>1.075 mm (0.0423 in.)</td></tr> <tr><td>1.100 mm (0.0433 in.)</td><td>1.125 mm (0.0443 in.)</td></tr> <tr><td>1.150 mm (0.0453 in.)</td><td>1.175 mm (0.0463 in.)</td></tr> <tr><td>1.200 mm (0.0472 in.)</td><td>1.225 mm (0.0482 in.)</td></tr> <tr><td>1.250 mm (0.0492 in.)</td><td>1.275 mm (0.0502 in.)</td></tr> <tr><td>1.300 mm (0.0512 in.)</td><td>1.325 mm (0.0522 in.)</td></tr> <tr><td>1.350 mm (0.0531 in.)</td><td>1.375 mm (0.0541 in.)</td></tr> <tr><td>1.400 mm (0.0551 in.)</td><td>1.425 mm (0.0561 in.)</td></tr> <tr><td>1.450 mm (0.0571 in.)</td><td>1.475 mm (0.0581 in.)</td></tr> <tr><td>1.500 mm (0.0591 in.)</td><td>1.525 mm (0.0600 in.)</td></tr> <tr><td>1.550 mm (0.0610 in.)</td><td>1.575 mm (0.0620 in.)</td></tr> <tr><td>1.600 mm (0.0630 in.)</td><td>1.625 mm (0.0640 in.)</td></tr> <tr><td>1.650 mm (0.0650 in.)</td><td>1.675 mm (0.0659 in.)</td></tr> <tr><td>1.700 mm (0.0669 in.)</td><td>1.725 mm (0.0679 in.)</td></tr> <tr><td>1.750 mm (0.0689 in.)</td><td>1.775 mm (0.0699 in.)</td></tr> <tr><td>1.800 mm (0.0709 in.)</td><td>1.825 mm (0.0719 in.)</td></tr> <tr><td>1.850 mm (0.0728 in.)</td><td>1.875 mm (0.0738 in.)</td></tr> <tr><td>1.900 mm (0.0748 in.)</td><td>1.925 mm (0.0758 in.)</td></tr> <tr><td>1.950 mm (0.0768 in.)</td><td></td></tr> </tbody> </table>	0.900 mm (0.0354 in.)	0.925 mm (0.0364 in.)	0.950 mm (0.0374 in.)	0.975 mm (0.0384 in.)	1.000 mm (0.0394 in.)	1.025 mm (0.0404 in.)	1.050 mm (0.0413 in.)	1.075 mm (0.0423 in.)	1.100 mm (0.0433 in.)	1.125 mm (0.0443 in.)	1.150 mm (0.0453 in.)	1.175 mm (0.0463 in.)	1.200 mm (0.0472 in.)	1.225 mm (0.0482 in.)	1.250 mm (0.0492 in.)	1.275 mm (0.0502 in.)	1.300 mm (0.0512 in.)	1.325 mm (0.0522 in.)	1.350 mm (0.0531 in.)	1.375 mm (0.0541 in.)	1.400 mm (0.0551 in.)	1.425 mm (0.0561 in.)	1.450 mm (0.0571 in.)	1.475 mm (0.0581 in.)	1.500 mm (0.0591 in.)	1.525 mm (0.0600 in.)	1.550 mm (0.0610 in.)	1.575 mm (0.0620 in.)	1.600 mm (0.0630 in.)	1.625 mm (0.0640 in.)	1.650 mm (0.0650 in.)	1.675 mm (0.0659 in.)	1.700 mm (0.0669 in.)	1.725 mm (0.0679 in.)	1.750 mm (0.0689 in.)	1.775 mm (0.0699 in.)	1.800 mm (0.0709 in.)	1.825 mm (0.0719 in.)	1.850 mm (0.0728 in.)	1.875 mm (0.0738 in.)	1.900 mm (0.0748 in.)	1.925 mm (0.0758 in.)	1.950 mm (0.0768 in.)	
0.900 mm (0.0354 in.)	0.925 mm (0.0364 in.)																																														
0.950 mm (0.0374 in.)	0.975 mm (0.0384 in.)																																														
1.000 mm (0.0394 in.)	1.025 mm (0.0404 in.)																																														
1.050 mm (0.0413 in.)	1.075 mm (0.0423 in.)																																														
1.100 mm (0.0433 in.)	1.125 mm (0.0443 in.)																																														
1.150 mm (0.0453 in.)	1.175 mm (0.0463 in.)																																														
1.200 mm (0.0472 in.)	1.225 mm (0.0482 in.)																																														
1.250 mm (0.0492 in.)	1.275 mm (0.0502 in.)																																														
1.300 mm (0.0512 in.)	1.325 mm (0.0522 in.)																																														
1.350 mm (0.0531 in.)	1.375 mm (0.0541 in.)																																														
1.400 mm (0.0551 in.)	1.425 mm (0.0561 in.)																																														
1.450 mm (0.0571 in.)	1.475 mm (0.0581 in.)																																														
1.500 mm (0.0591 in.)	1.525 mm (0.0600 in.)																																														
1.550 mm (0.0610 in.)	1.575 mm (0.0620 in.)																																														
1.600 mm (0.0630 in.)	1.625 mm (0.0640 in.)																																														
1.650 mm (0.0650 in.)	1.675 mm (0.0659 in.)																																														
1.700 mm (0.0669 in.)	1.725 mm (0.0679 in.)																																														
1.750 mm (0.0689 in.)	1.775 mm (0.0699 in.)																																														
1.800 mm (0.0709 in.)	1.825 mm (0.0719 in.)																																														
1.850 mm (0.0728 in.)	1.875 mm (0.0738 in.)																																														
1.900 mm (0.0748 in.)	1.925 mm (0.0758 in.)																																														
1.950 mm (0.0768 in.)																																															
Fuel heater	Resistance	at 20°C (68°F)	0.5 – 2.0 Ω																																												
Injection pump	Drive shaft thrust clearance (Reference)		0.15 – 0.55 mm (0.0059 – 0.0217 in.)																																												

TORQUE SPECIFICATION

Part tightened	N·m	kgf·cm	ft·lbf
Fuel inlet hollow screw x Injection pump body	36.8	375	27
Delivery valve holder x Distributive head	58.85	600	43
Distributive head plug x Injection pump	88	900	65
Fuel inlet pipe x Injection pump	24.5	250	18
Fuel inlet pipe x Injection pump	24.5	250	18
Injection pump x Timing gear case	21	210	15
Fuel temperature sensor x Distributive head plug (No. 2)	21.6	220	16
Pump stay x Injection pump	32	330	24
Pump stay x Cylinder block	21	210	15
Injection pump drive gear x Injection pump	64	650	47
Fuel heater x Fuel filter	1.96	20	17 in.·lbf

LUBRICATION

TORQUE SPECIFICATION

SS0YP-02

Part tightened	N·m	kgf·cm	ft·lbf
Oil pan x Drain plug	34	350	25
Relief valve x Oil pump	42	425	31
Oil pump x Cylinder block	Bolt	13	10
	Union bolt	16	12
Injection pump x Oil pump	21	210	15
Oil strainer x Cylinder block	8	80	71 in·lbf
Oil pan x Cylinder block	16	165	12
Alternator adjusting bar x Oil pump	21	210	15

STARTING

SERVICE DATA

SS0YU-04

Pre-heating system	Light lighting time	at 30°C (86°F) Approx. 0.5 seconds
--------------------	---------------------	------------------------------------

DIAGNOSTICS

ENGINE	DI-1
HOW TO PROCEED WITH TROUBLESHOOTING	DI-1
CUSTOMER PROBLEM ANALYSIS CHECK	DI-3
PRE-CHECK	DI-4
DIAGNOSTIC TROUBLE CODE CHART	DI-14
PARTS LOCATION	DI-16
TERMINALS OF ECU	DI-18
PROBLEM SYMPTOMS TABLE	DI-24
CIRCUIT INSPECTION	DI-26

ENGINE

HOW TO PROCEED WITH TROUBLESHOOTING

DB1H-08

When using hand-held tester, troubleshoot in accordance with the procedure on the following pages.

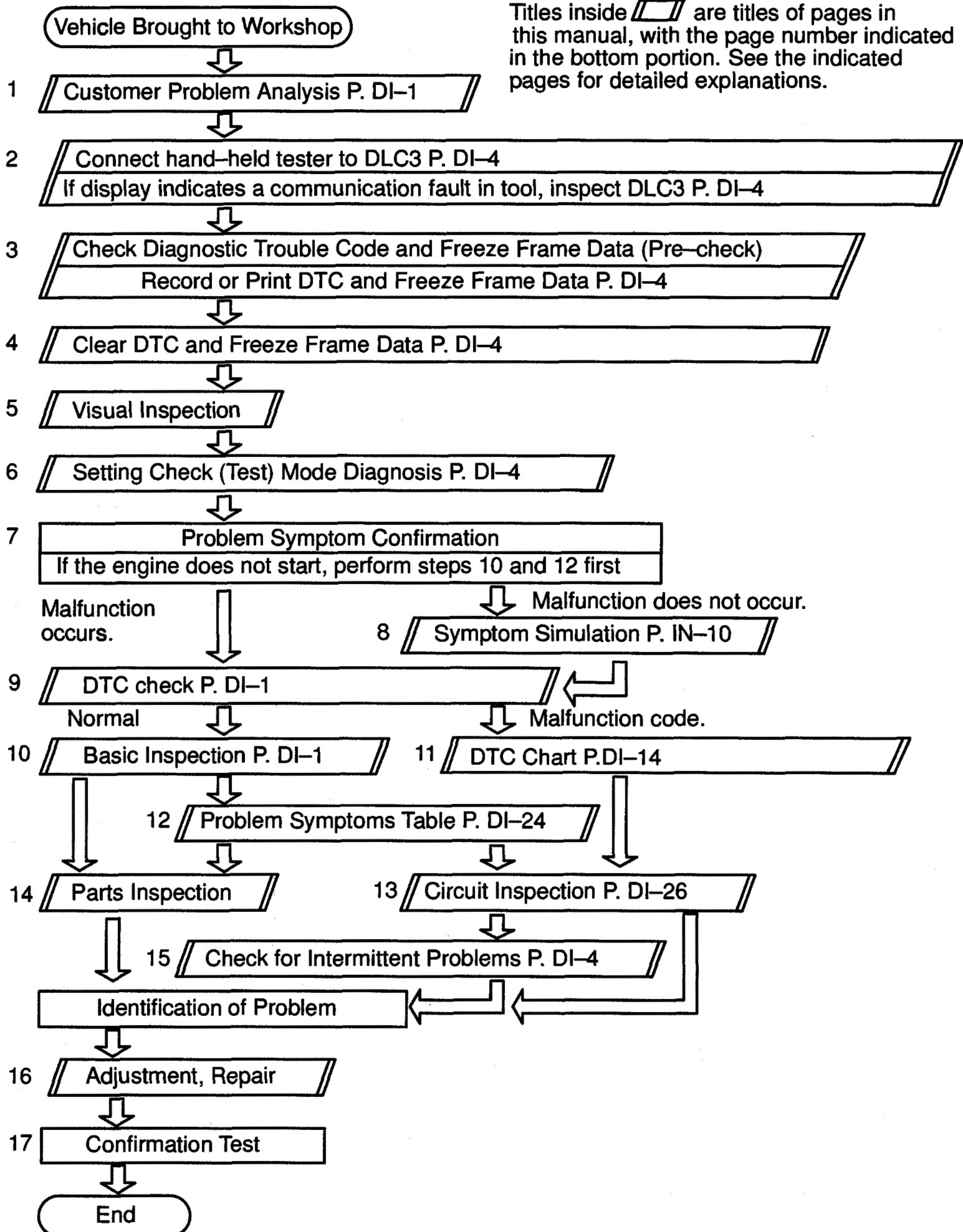

CUSTOMER PROBLEM ANALYSIS CHECK

ENGINE CONTROL SYSTEM Check Sheet

Inspector's Name _____

Customer's Name		Model and Model Year	
Driver's Name		Frame No.	
Date Vehicle Brought in		Engine Model	
License No.		Odometer Reading	km miles

Problem Symptoms	<input type="checkbox"/> Engine does not Start	<input type="checkbox"/> Engine does not crank	<input type="checkbox"/> No initial combustion	<input type="checkbox"/> No complete combustion
	<input type="checkbox"/> Difficult to Start	<input type="checkbox"/> Engine cranks slowly <input type="checkbox"/> Other _____		
	<input type="checkbox"/> Poor Idling	<input type="checkbox"/> Incorrect first idle <input type="checkbox"/> Idling rpm is abnormal <input type="checkbox"/> High (rpm) <input type="checkbox"/> Low (rpm) <input type="checkbox"/> Rough idling <input type="checkbox"/> Other _____		
	<input type="checkbox"/> Poor Driveability	<input type="checkbox"/> Hesitation <input type="checkbox"/> Back fire <input type="checkbox"/> Muffler explosion (after-fire) <input type="checkbox"/> Surging <input type="checkbox"/> Knocking <input type="checkbox"/> Other _____		
	<input type="checkbox"/> Engine Stall	<input type="checkbox"/> Soon after starting <input type="checkbox"/> After accelerator pedal depressed <input type="checkbox"/> After accelerator pedal released <input type="checkbox"/> During A/C operation <input type="checkbox"/> Shifting from N to D <input type="checkbox"/> Other _____		
	<input type="checkbox"/> Others	_____		

Date Problem Occurred		_____		
Problem Frequency		<input type="checkbox"/> Constant <input type="checkbox"/> Sometimes (times per day/month) <input type="checkbox"/> Once only <input type="checkbox"/> Other _____		
Condition When Problem Occurs	Weather	<input type="checkbox"/> Fine <input type="checkbox"/> Cloudy <input type="checkbox"/> Rainy <input type="checkbox"/> Snowy <input type="checkbox"/> Various/Other _____		
	Outdoor Temperature	<input type="checkbox"/> Hot <input type="checkbox"/> Warm <input type="checkbox"/> Cool <input type="checkbox"/> Cold (approx. _____ °F/_____ °C)		
	Place	<input type="checkbox"/> Highway <input type="checkbox"/> Suburbs <input type="checkbox"/> Inner City <input type="checkbox"/> Uphill <input type="checkbox"/> Downhill <input type="checkbox"/> Rough road <input type="checkbox"/> Other _____		
	Engine Temp.	<input type="checkbox"/> Cold <input type="checkbox"/> Warming up <input type="checkbox"/> After warming up <input type="checkbox"/> Any temp. <input type="checkbox"/> Other _____		
	Engine Operation	<input type="checkbox"/> Starting <input type="checkbox"/> Just after starting (min.) <input type="checkbox"/> Idling <input type="checkbox"/> Racing <input type="checkbox"/> Driving <input type="checkbox"/> Constant speed <input type="checkbox"/> Acceleration <input type="checkbox"/> Deceleration <input type="checkbox"/> A/C switch ON/OFF <input type="checkbox"/> Other _____		

Condition of Malfunction indicator Lamp		<input type="checkbox"/> Remains on <input type="checkbox"/> Sometimes lights up <input type="checkbox"/> Does not light up		
Diagnostic Trouble Code Inspection	Normal mode (Pre-check)	<input type="checkbox"/> Normal <input type="checkbox"/> Malfunction code(s) (code) <input type="checkbox"/> Freeze frame data ()		
	Check Mode	<input type="checkbox"/> Normal <input type="checkbox"/> Malfunction code(s) (code) <input type="checkbox"/> Freeze frame data ()		

DI

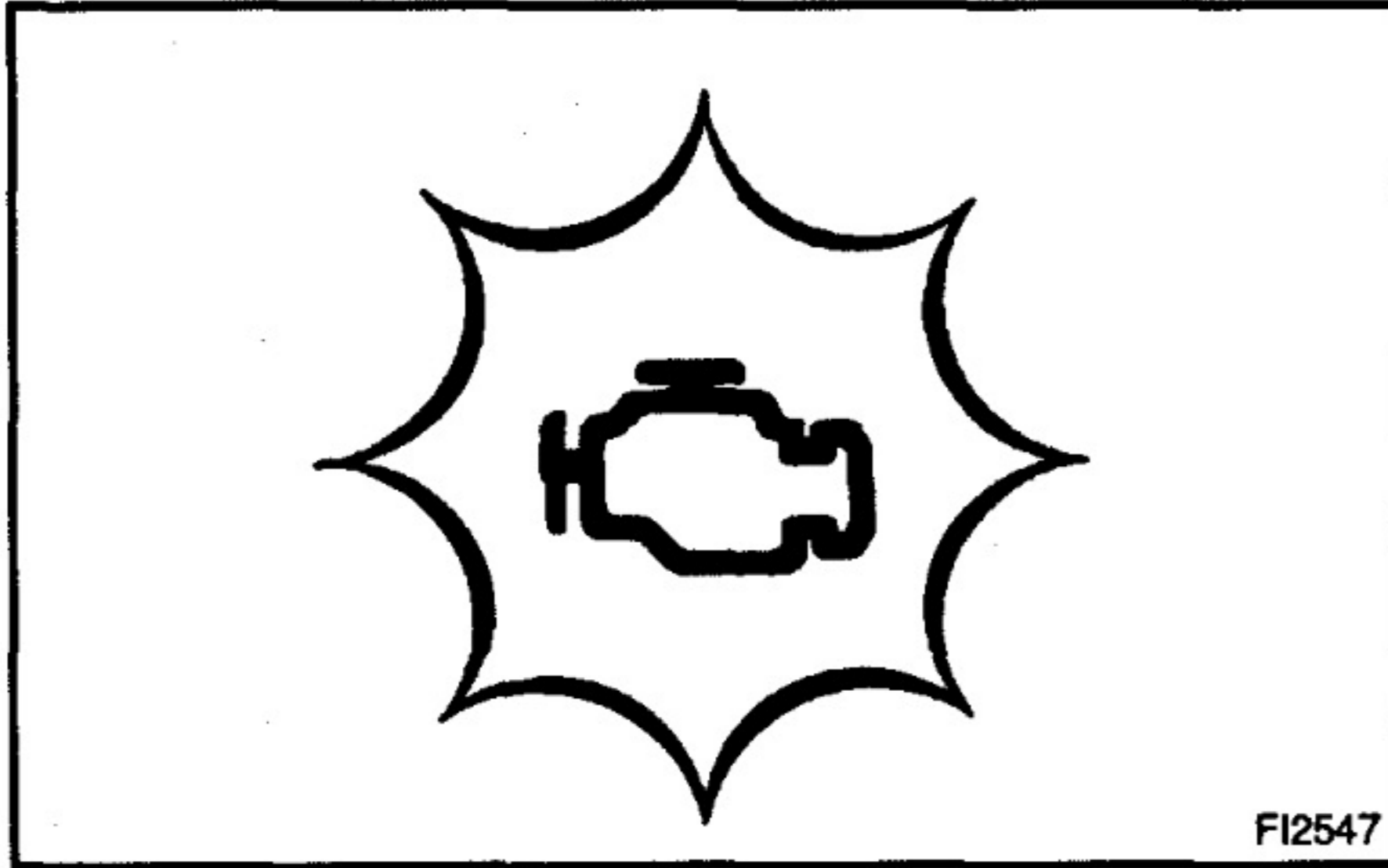

FI2547

PRE-CHECK

1. DIAGNOSIS SYSTEM

(a) Description

- When troubleshooting Multiplex OBD (M-OBD) vehicles, the only difference from the usual troubleshooting procedure is that you need to connect the vehicle to the hand-held tester, and read off various data output from the vehicle's engine ECU.
- The vehicle's on-board computer lights up the check engine warning light on the instrument panel when the computer detects a malfunction in the computer itself or in drive system components. In addition to the check engine warning light lighting up when a malfunction is detected, the applicable diagnostic trouble codes are recorded in the engine ECU memory. (See page DI-14)

If the malfunction has been repaired, the check engine warning light goes off automatically but the diagnostic trouble codes remain recorded in the engine ECU memory.

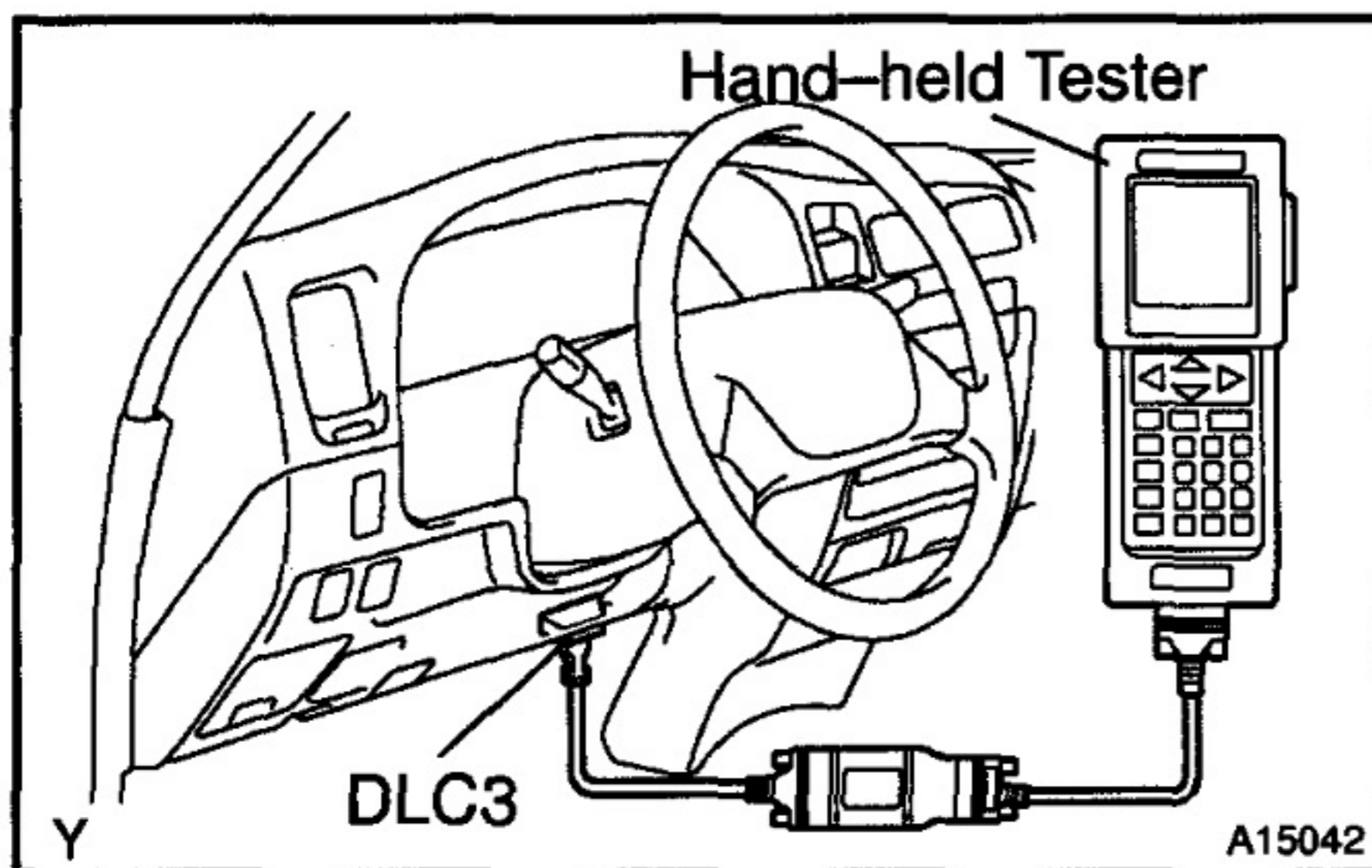

- To check the diagnostic trouble codes, connect the hand-held tester to the Data Link Connector 3 (DLC3) on the vehicle or read the number of blinks of the check engine warning light when TC and CG terminals on the DLC3 are connected. The hand-held tester also enables you to erase the diagnostic trouble codes and activate the several actuators and check freeze frame data and various forms of engine data. (For operating instructions, see the hand-held tester instruction book.)
- The diagnosis system operates in the normal mode during a normal vehicle use. It also has a check (test) mode for technicians to simulate malfunction symptoms and troubleshoot. Some diagnostic trouble codes use 2 trip detection logic* to prevent an erroneous detection and ensure thorough the malfunction detection. By switching the engine ECU to the check (test) mode using hand-held tester when troubleshooting, a technician can cause the check engine warning light to light up for a malfunction that is only detected once or momentarily. (hand-held tester only) (See page DI-14)

- *2 trip detection logic:
When a logic malfunction is first detected, the malfunction is temporarily stored in the engine ECU memory.

If the same malfunction is detected again during the second drive test, this second detection causes the check engine warning light to light up. The 2 trip repeats the same mode twice time. (However, the ignition switch must be turned OFF between the 1st trip and 2nd trip).

- Freeze frame data:
Freeze frame data records the engine condition when a malfunction is detected, as freeze frame data records the engine conditions (fuel system, calculator load, engine coolant temperature, fuel trim, engine speed, vehicle speed, etc.) when the malfunction is detected. When troubleshooting, it is useful for determining whether the vehicle was running or stopped, the engine was warmed up or not, the air-fuel ratio was lean or rich, etc. at the time of the malfunction.

(b) Check the DLC3.

The vehicle's engine ECU uses ISO 14230 for communication. The terminal arrangement of DLC3 complies with SAE J1962 and matches the ISO 14230 format.

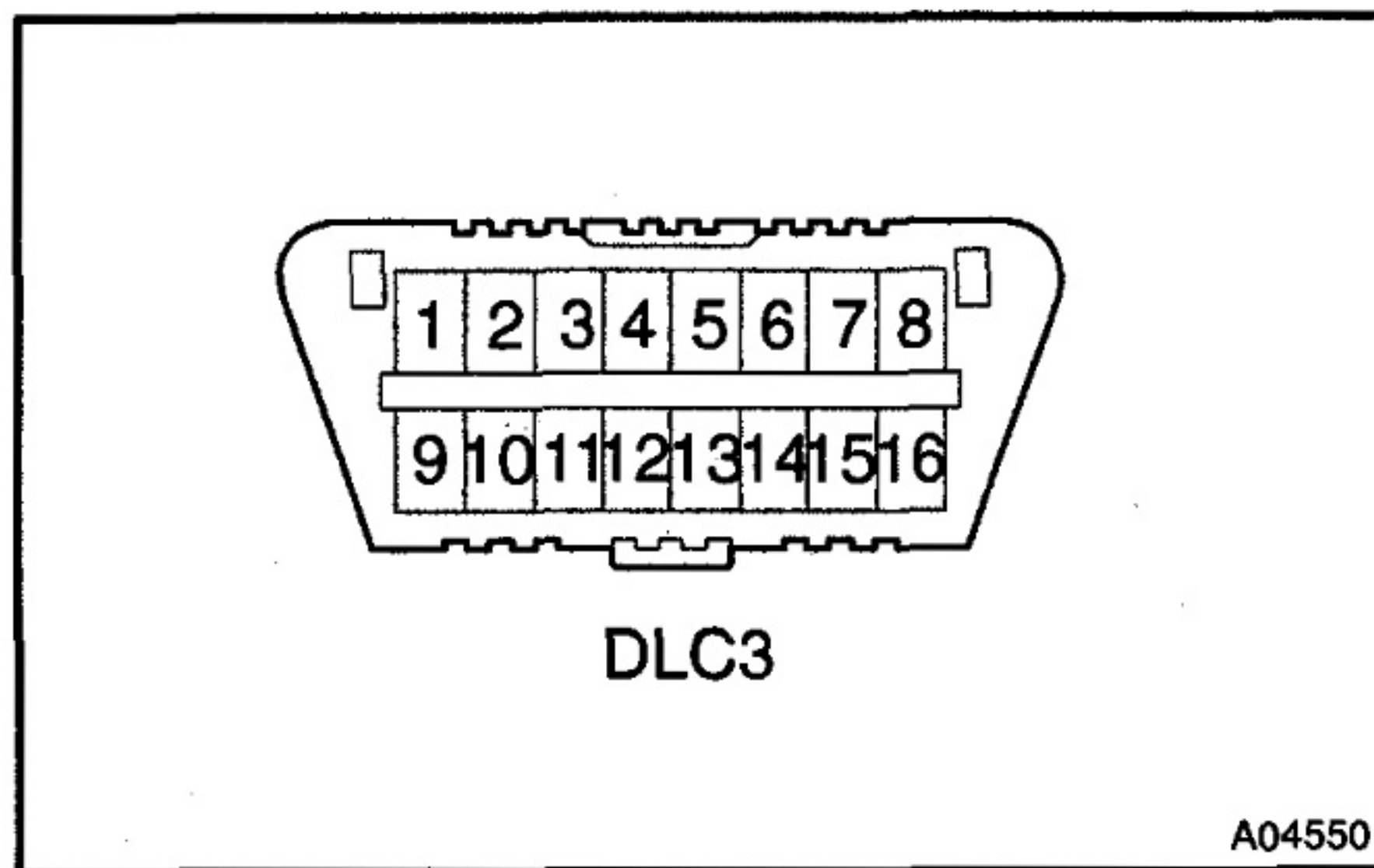

Terminal No.	Connection/Voltage or Resistance	Condition
7	Bus+ Line/Pulse generation	During transmission
4	Chassis Ground - Body Ground/1 Ω or less	Always
16	Battery Positive - Body Ground/9 - 14 V	Always

HINT:

If your display shows **UNABLE TO CONNECT TO VEHICLE** when you have connected the cable of the hand-held tester to the DLC3, turned the ignition switch ON and operated the hand-held tester, there is a problem on the vehicle side or tool side.

- If the communication is normal when the tool is connected to another vehicle, inspect the DLC3 on the original vehicle.
- If the communication is still impossible when the tool is connected to another vehicle, the problem is probably in the tool itself, so consult the Service Department listed in the tool's instruction manual.

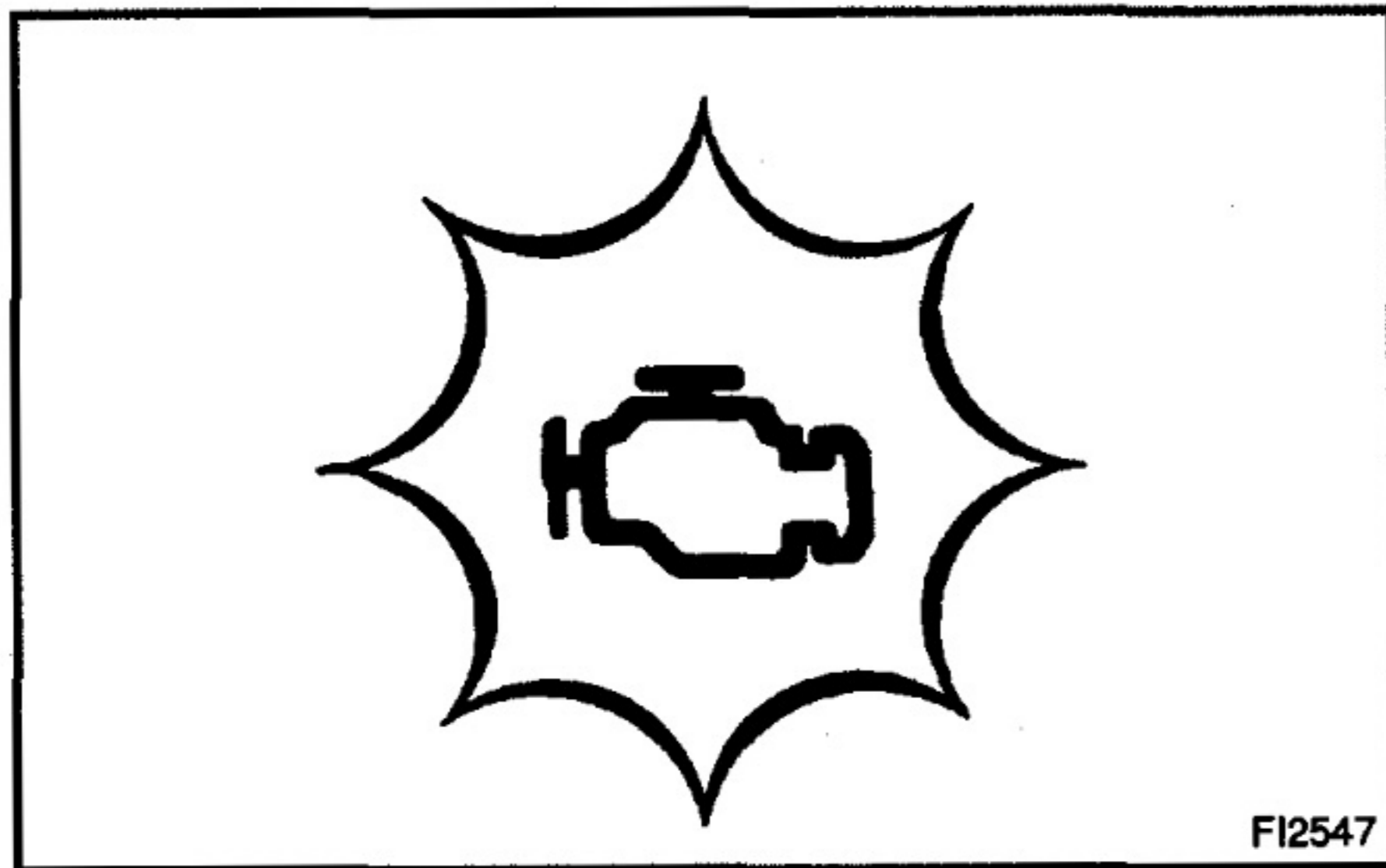

2. Normal Mode: INSPECT DIAGNOSIS

- (a) Check the check engine warning light.
- (1) The check engine warning light comes on when the ignition switch is turned ON and the engine is not running.

HINT:

If the check engine warning light does not light up, troubleshoot the combination meter.

- (2) when the engine is started, the check engine warning light should go off. If the lamp remains on, the diagnosis system has detected a malfunction or abnormality in the system.

- (b) Check the DTC using hand-held tester.

NOTICE:

When the diagnosis system is switched from the normal mode to the check (test) mode, all the DTCs and freeze frame data recorded in the normal mode will be erased. So before switching modes, always check the DTCs and freeze frame data, and note them down.

- (1) Prepare the hand-held tester.
- (2) Connect the hand-held tester to the DLC3.
- (3) Turn the ignition switch ON and the hand-held tester main switch ON.
- (4) Use the hand-held tester to check the DTCs and freeze frame data. (for operating instructions, see the hand-held tester's instruction book.)
- (5) Confirm the details of the DTCs.

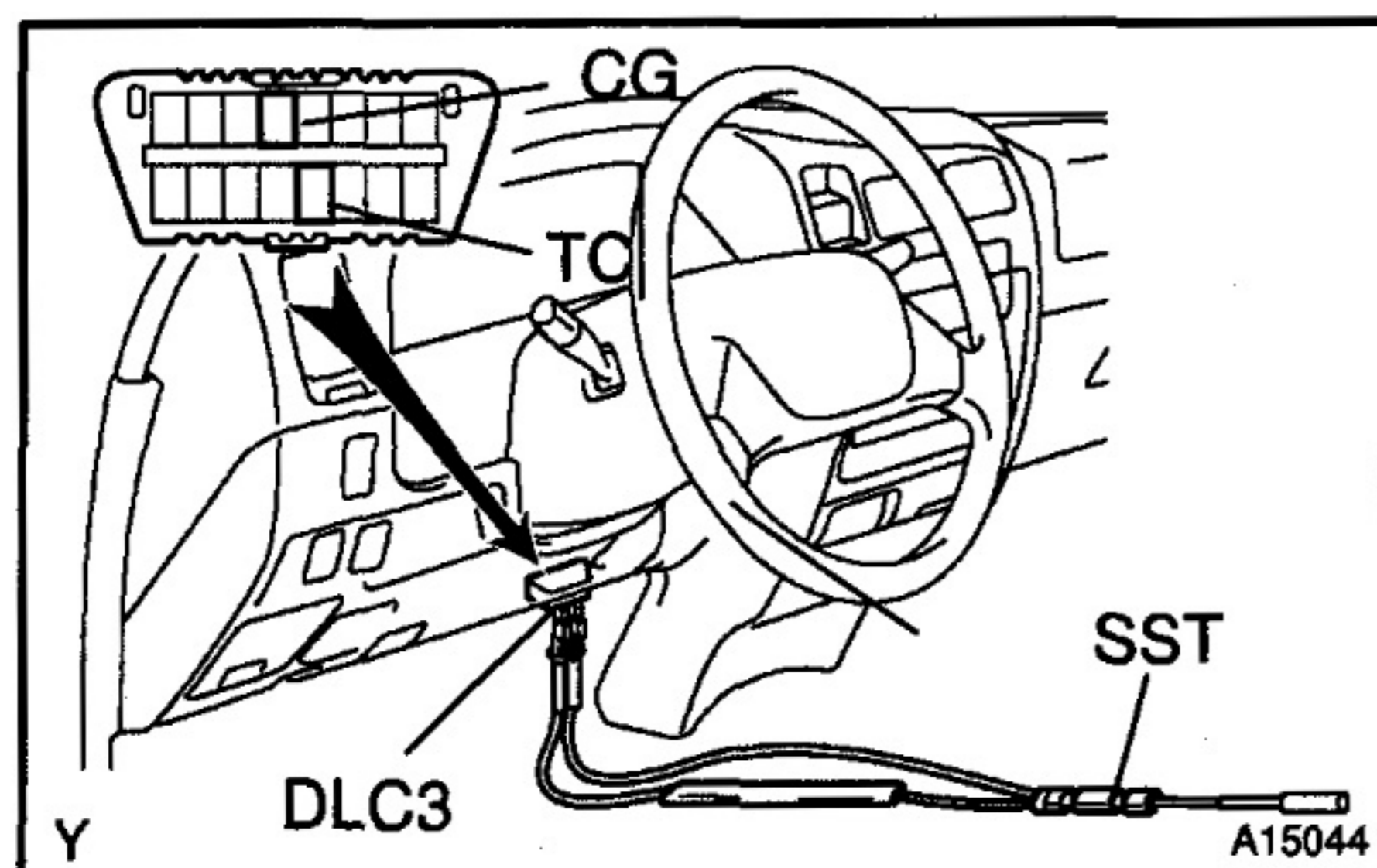

- (c) Check the DTC not using hand-held tester.

- (1) Turn the ignition switch ON.
- (2) Using SST, connect terminals 13 (TC) and 4 (CG) of the DLC3 together.

SST 09843-18040

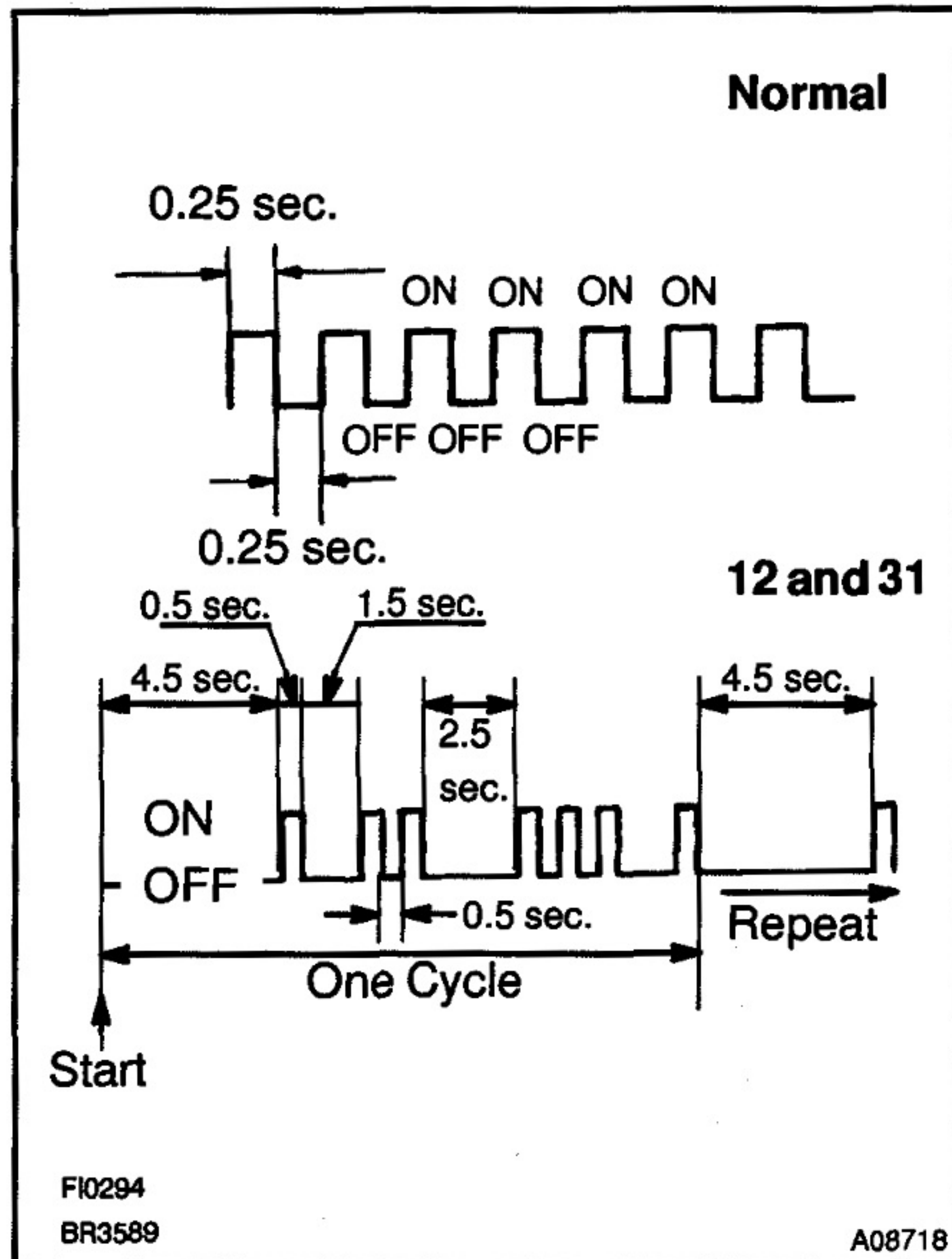

- (3) Read the DTC from the check engine warning light. As an example, the blinking patterns for codes; normal, 12 and 31 are as shown in the illustration.

HINT:

If the TC is not output, check the diagnostic connector (DLC3) circuit (See page DI-98).

- (4) Check the details of the malfunction using the DTC chart on page DI-14.
- (5) After completing the check, disconnect terminals 13 (TC) and 4 (CG) and turn off the display.

HINT:

In the event of 2 or more malfunction codes, the indication will begin from the smaller numbered code to the larger in order.

NOTICE:

When simulating symptoms without a hand-held tester to check the DTCs, use the normal mode. For code on the DTCs chart subject to "2 trip detection logic", turn the ignition switch OFF after the symptom is simulated once. Then repeat the simulation process again. When the problem has been simulated twice, the check engine warning light lights up and the DTCs are recorded in the engine ECU.

3. Check (Test) Mode:**INSPECT DIAGNOSIS**

Hand-held tester only:

Compared to the normal mode, the check mode has a further sensitivity to detect malfunctions.

Furthermore, the same diagnostic items which are detected in the normal mode can also be detected in the check (test) mode.

(a) Check the DTC.

- (1) Initial conditions.
 - Battery voltage 22 V or more
 - Throttle valve fully closed.
 - Transmission in the neutral position
- (2) Turn the ignition switch OFF.
- (3) Prepare the hand-held tester.
- (4) Connect the hand-held tester to the DLC3.
- (5) Turn the ignition switch ON and push the hand-held tester main switch ON.
- (6) Switch the hand-held tester from the normal mode to the check (test) mode (Check that the check engine warning light flashes.).
- (7) Start the engine (The check engine warning light goes off after the engine starts.).
- (8) Simulate the conditions of the malfunction described by the customer.

NOTICE:

Leave the ignition switch ON until you have checked the DTCs, etc.

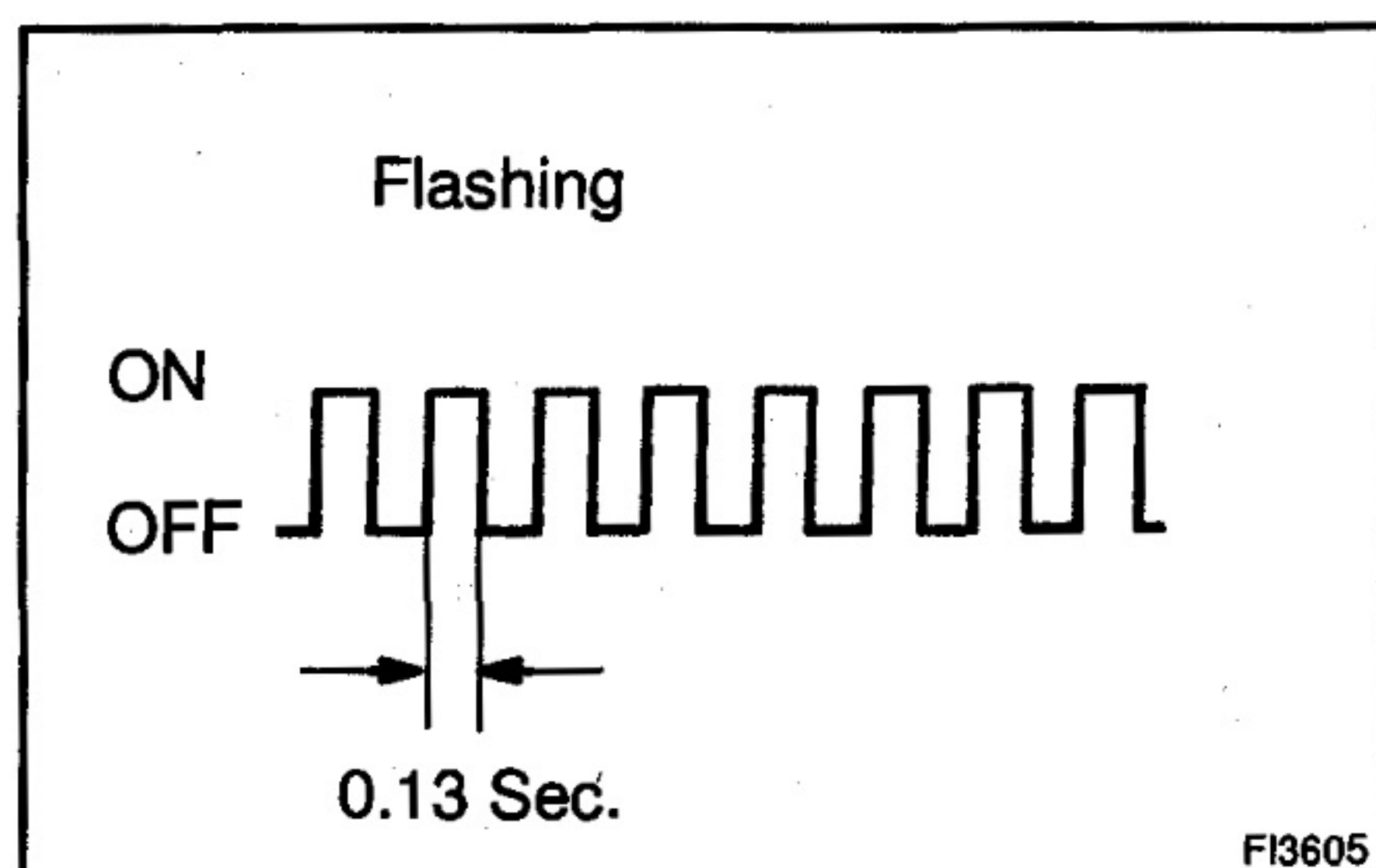

- (9) After simulating the malfunction conditions, use the hand-held tester diagnosis selector to check the DTCs and freeze frame data, etc.

HINT:

Take care not to turn the ignition switch OFF. Turning the ignition switch OFF switches the diagnosis system from the check (test) mode to the normal mode, so all the diagnostic codes, etc. are erased.

- (10) After checking the DTCs, inspect the applicable circuit.

- (b) Clear the DTC.

The following actions will erase the DTCs and freeze frame data.

- Operating the hand-held tester to erase the codes. (See the hand-held tester's instruction book for operating instructions.)
- Disconnecting the battery terminals, ECD fuse.

NOTICE:

If the hand-held tester switches the engine ECU from the normal mode to the check (test) mode or vice-versa, or if the ignition switch is turned from ON to ACC or OFF during the check (test) mode, the DTCs and freeze frame data will be erased.

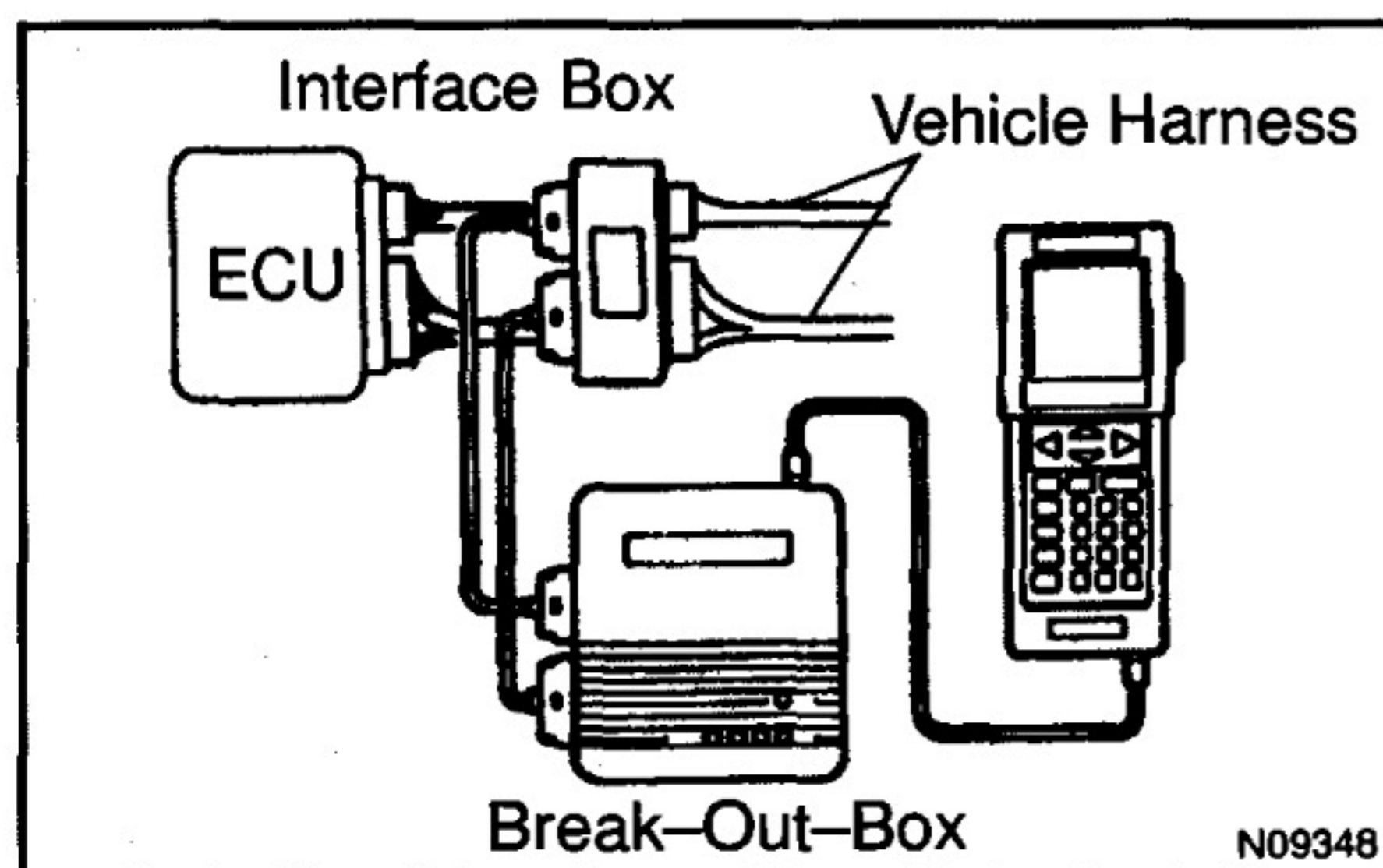

- (c) Measure the engine ECU terminal values using break-out box and hand-held tester.

- (1) Connect up the break-out-box and hand-held tester to the vehicle.
- (2) Read the engine ECU input/output values by following the prompts on the tester screen.

HINT:

Hand-held tester has a "Snapshot" function.

This records the measured values and is effective in the diagnosis of intermittent problems.

Please refer to the hand-held tester/break-out-box operator's manual for further details.

4. FAIL-SAFE CHART

If any of the following codes is recorded, the engine ECU enters fail-safe mode.

DTC No.	Fail-Safe Operation	Fail-Safe Deactivation Conditions
12	TCV duty is fixed at 30.0 %	2 of more TDC signals are detected for 4 engine revolution
13	<ul style="list-style-type: none"> •Fuel cut •TCV duty is fixed at 1.0 % •Close diesel throttle valve 	2 of more NE signals are detected for 0.5 sec.

19(1)	Accelerator pedal closed position SW ON : Accelerator pedal position is fixed at 0 % Accelerator pedal closed position SW OFF : Accelerator pedal position is fixed at 8 %	+B OFF
19(2)	Accelerator pedal closed position SW ON : Accelerator pedal position is fixed at 0 % Accelerator pedal closed position SW OFF : Accelerator pedal position is fixed at 8 %	+B OFF
	Accelerator pedal position below 10 %	+B OFF
19(3)	When the idle SW is faulty. Accelerator pedal closed position SW ON: Accelerator pedal position is fixed at 0 % Accelerator pedal closed position SW OFF: Accelerator pedal position is fixed at 8 %	+B OFF
	When the idle SW is okay. Idle SW ON : Accelerator pedal position is fixed at 0 % Idle SW OFF : Accelerator pedal position below 10 %	+B OFF
19(4)	Accelerator pedal position below 10 %	+B OFF
22	Engine coolant temp. is fixed at 100°C (212°F)	Return to normal condition
24	Intake air temp. is fixed at 20°C (68°F)	Return to normal condition
35	Intake air pressure is fixed at 101.3 kPa (760 mmHg, 30 in.Hg)	Return to normal condition
39	Fuel temp. is fixed at 60°C (140°F)	Return to normal condition
42	Vehicle speed is fixed at 0 km/h (0 mph)	Vehicle speed > 0 km/h (0 mph)

5. CHECK FOR INTERMITTENT PROBLEMS

Hand-held tester only:

By putting the vehicle's engine ECU in the check (test) mode, 1 trip detection logic is possible instead of 2 trip detection logic and sensitivity to detect open circuits is increased. This makes it easier to detect intermittent problems.

- (1) Clear the DTC (See step 2).
- (2) Set the check (test) mode (See step 3).
- (3) Perform a simulation test (See page IN-10).
- (4) Check the connector and terminal (See page IN-20).
- (5) Handle the connector (See page IN-20).

6. BASIC INSPECTION

When the malfunction code is not confirmed in the DTC check, troubleshooting should be carried out in all the possible circuits to be considered as causes of the problems.

In many cases, by carrying out the basic engine check shown in the following flow chart, the location causing the problem can be found quickly and efficiently. Therefore use of this check is essential in the engine troubleshooting.

1	Is battery positive voltage 11 V or more when engine is stopped?
----------	---

NO

Charge or replace battery.

YES

2 Is engine cranked?

NO

Proceed to problem symptoms table on page DI-24.

YES

DI

3 Check air filter.

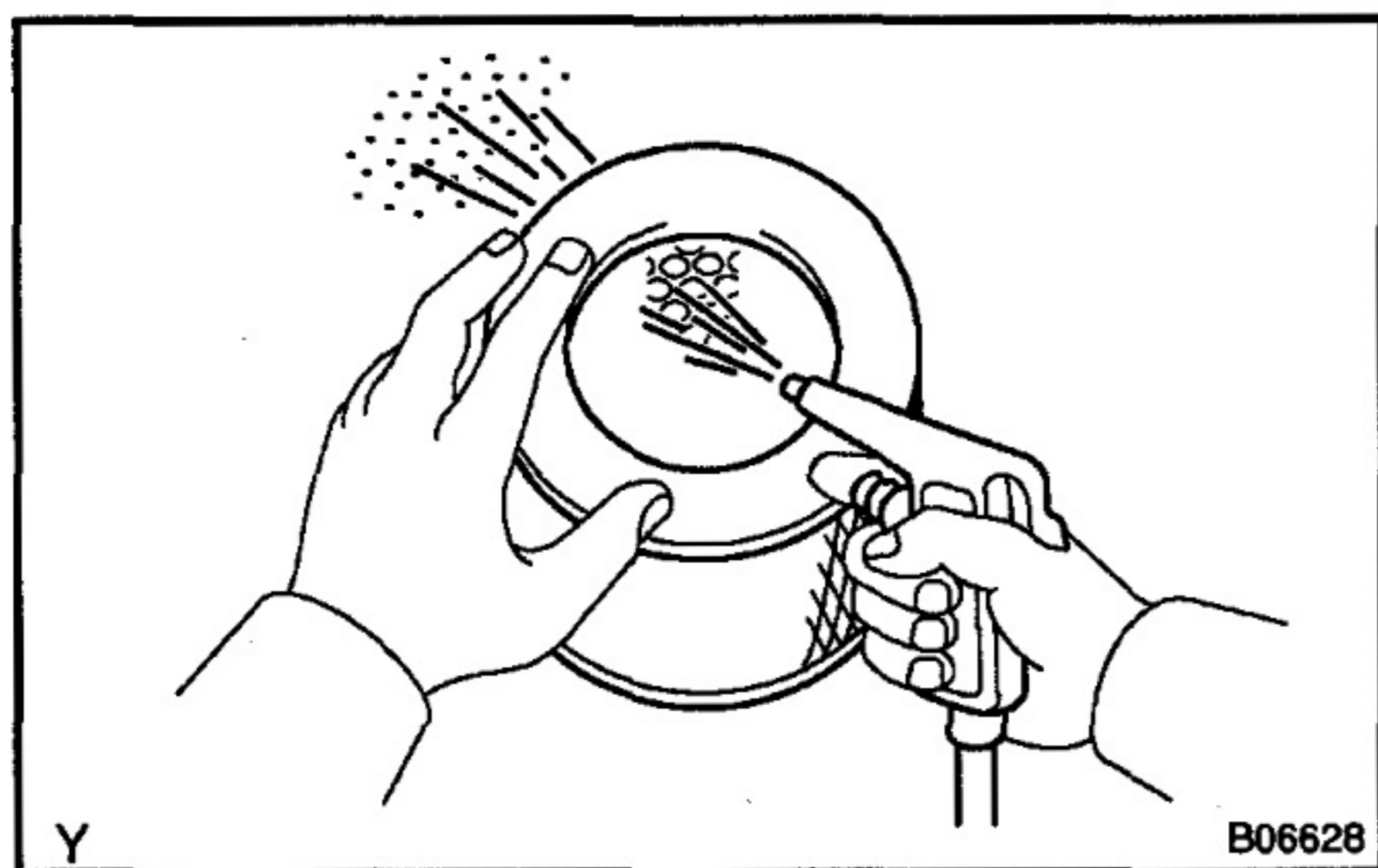

Paper filter type:

PREPARATION:

Remove the air filter.

CHECK:

Visually check that the air filter is not excessively dirty or oily.

HINT:

If necessary, clear the air filter with compressed air excessively dirty or oily.

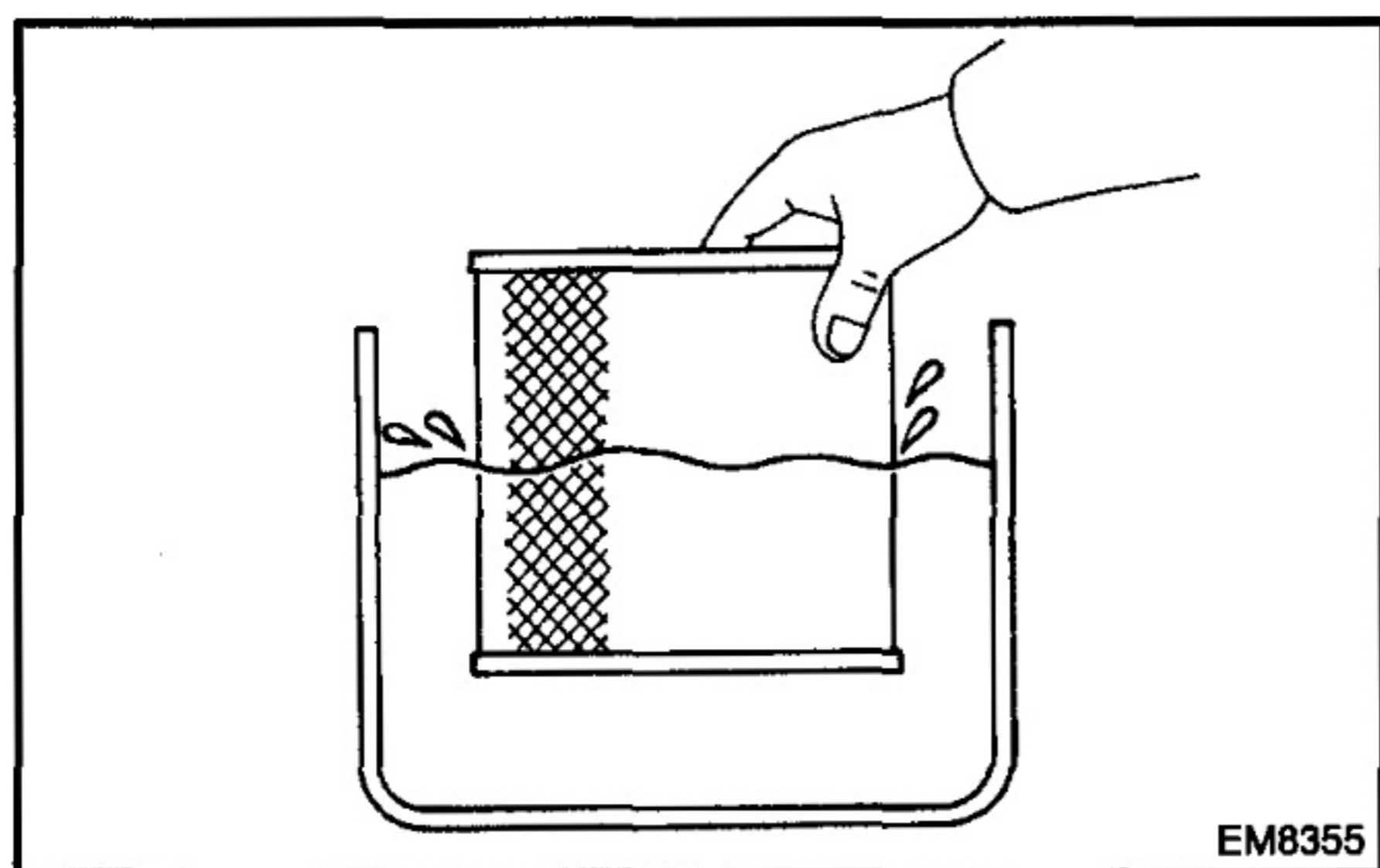

Washable type:

PREPARATION:

Remove the air filter.

CHECK:

Visually check that the air filter is not excessively dirty or oily.

If necessary, clean the air filter.

- (1) Blow dirt off in the filter element with compressed air.
- (2) Submerge the filter element in the water and agitate it up and down more than 10 times.
- (3) Repeat rinsing in clean water until rinsing water is clear.
- (4) Remove excess water by shaking the filter element or blowing with compressed air.

NOTICE:

Do not beat or drop the filter element.

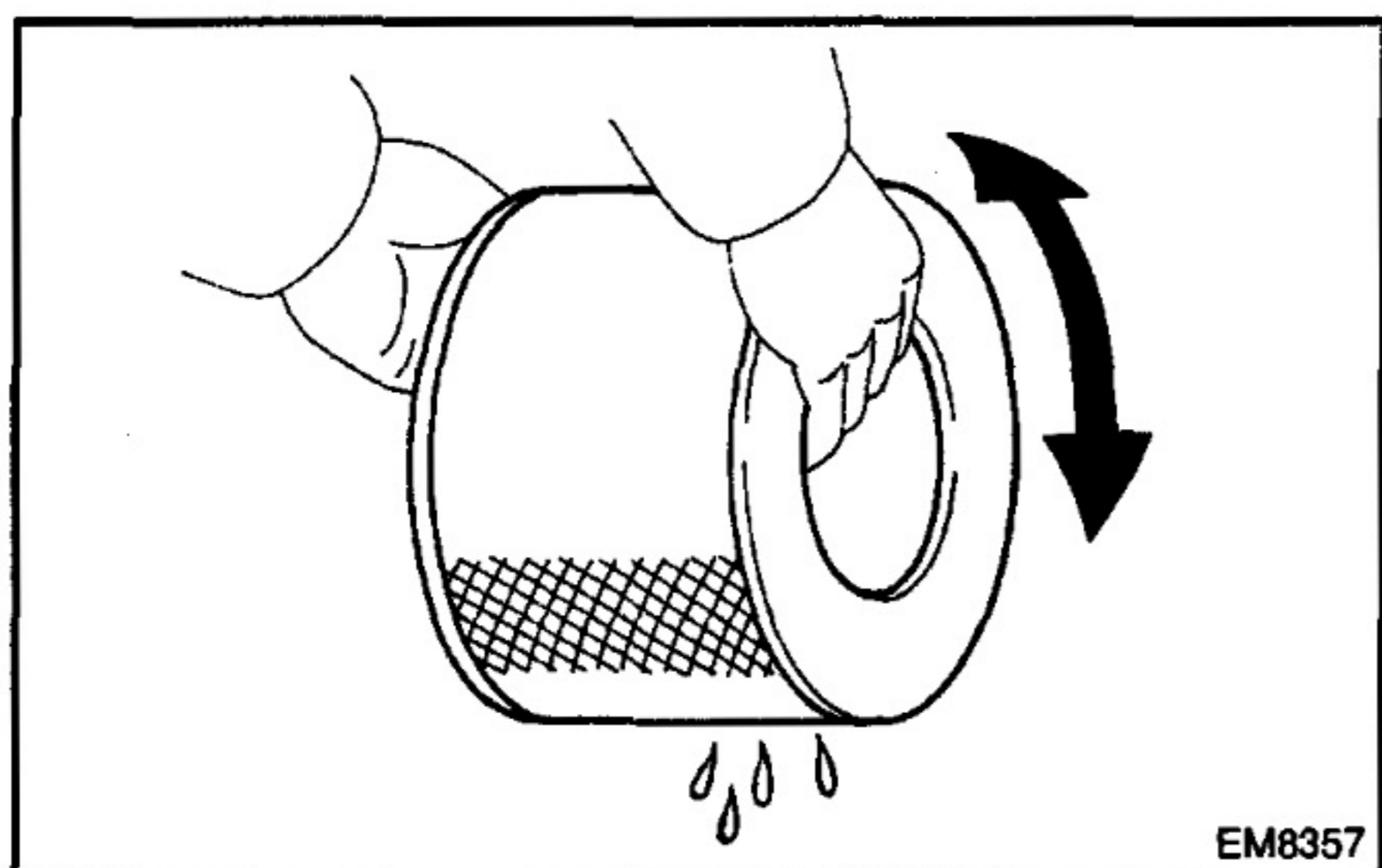

NG

Repair or replace.

OK

4 Check fuel quality.

CHECK:

- Check that only diesel fuel is used.
- Check that the fuel does not contain any impurity.

NG

Replace fuel.

OK

5 Check engine oil (See page LU-1).

NG

Add or replace.

OK

6 Check coolant (See page CO-1).

NG

Replace coolant.

OK

7 Check injection timing (See Pub. No. RM710E, EM section).

NG

Adjust injection timing.

OK

8 Check idle speed and maximum speed (See page EM-1).

NG

Repair or replace injection pump.

OK

9 Check diagnostic connector (DLC3) circuit (See page DI-98).

NG Repair or replace.

OK

10 Check vacuum pump (See page EC-3).

NG Repair or replace.

OK

Proceed to problem symptoms table on page DI-24.

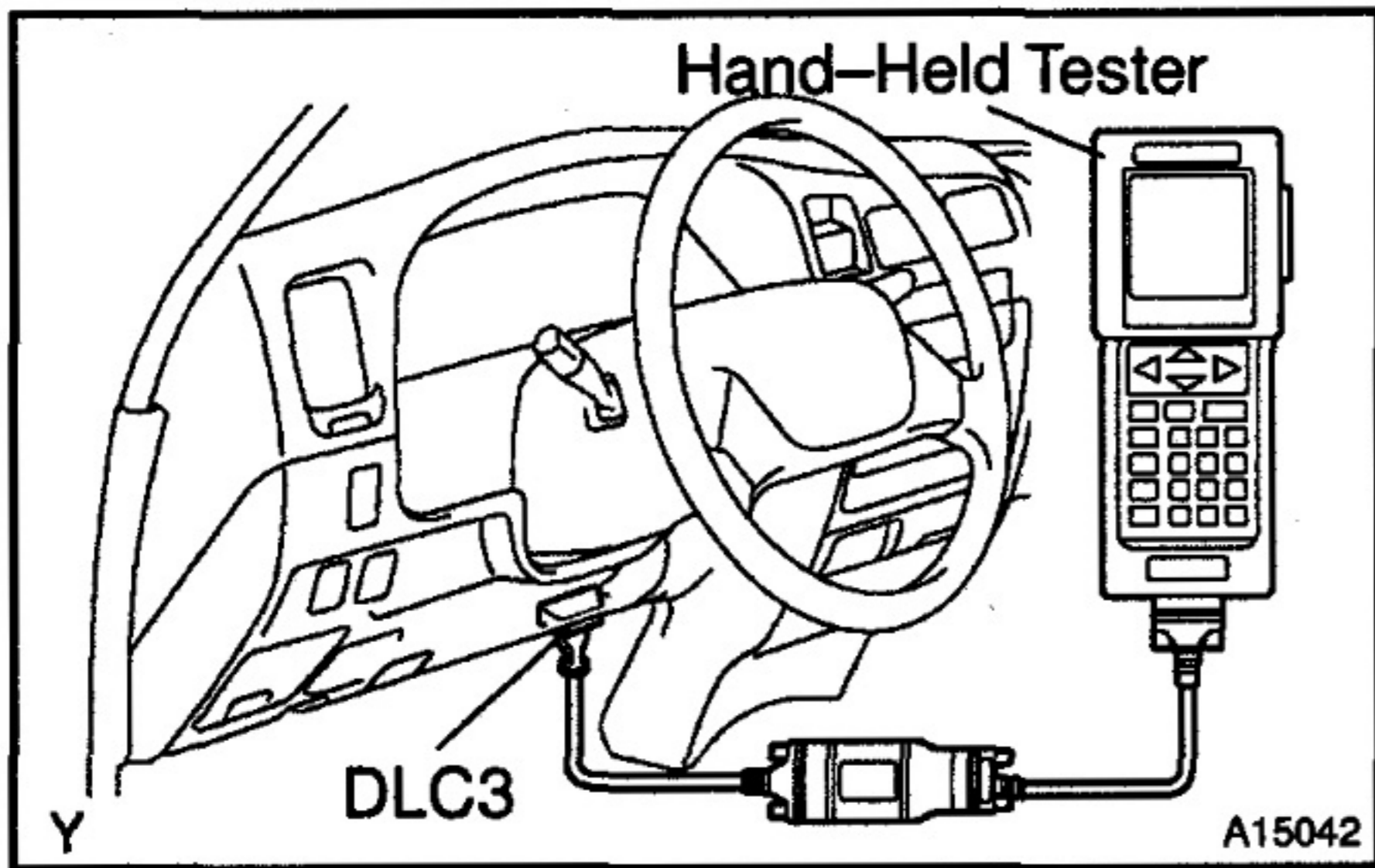

7. REFERENCE VALUE OF ENGINE ECU DATA

NOTICE:

The values given below for "Normal Condition" are representative values, so a vehicle may still be normal even if its values from those listed here. So do not solely depend on the Normal condition here when deciding whether a part is faulty or not.

HINT:

Engine engine ECU data can be monitored by hand-held tester.

- (a) Connect the hand-held tester to the DLC3.
- (b) Monitor the engine ECU data by following the prompts on the tester screen.

Please refer to the hand-held tester operator's manual for further detail.

(c) Reference Value

Item	Inspection Condition	Reference Value
INJECTION VOLUME	Engine at idling *1	5 – 25 mm ³
	Engine racing at 2,000 rpm *1	5 – 12 mm ³
	Engine racing at 3,000 rpm *1	9 – 18 mm ³
INJECTION TIMING	Engine at idling *1	12.5 – 15.0°CA
	Engine racing at 2,000 rpm *1	16.0 – 20.5°CA
	Engine racing at 3,000 rpm *1	21.5 – 24.0°CA
ENGINE SPD	RPM kept stable (Comparison with tachometer)	No great changes

DIAGNOSTICS - ENGINE

PIM	Engine at idling *1	80 - 100 kPa (683-833 mmHg, 26.9-32.8 in.Hg)
	Engine racing at 2,000 rpm *1	80 - 120 kPa
	Engine racing at 3,000 rpm *1	110 - 150 kPa
COOLANT TEMP	Engine at normal operating temp.	75 - 95°C (167 - 203°F) *2
INTAKE AIR	Engine at normal operating temp.	Ambient temp. - 140°C
FUEL TEMP	Engine at normal operating temp.	Ambient temp. - 65°C
ACCELE POSITION	Accelerator pedal fully closed	0 - 34 %
	Accelerator pedal fully opened	58 - 100 %
	From closed position to wide open accelerator pedal	Gradually increases
VEHICLE SPD	During driving (Comparison with speed meter)	No large differences
A/C SIG	A/C switch ON	ON
IDL SIG	Accelerator pedal full closed	ON
STARTER SIG	During cranking	ON
A/C CUT SIG	A/C switch OFF	ON
EGR SYSTEM	Idling	ON
NSW *3	Neutral start switch signal	P or N position : ON
PS OIL PRESS SW	Power steering oil pressure switch signal	Turn steering wheel : ON
ACCEL CLOSE SW	Accelerator pedal fully closed	ON

*1: All the accessories and A/C are switched OFF.

*2: If the water temperature sensor circuit is open or short, the engine ECU operates the fail safe operation.

*3: Only for A/T.

DIAGNOSTIC TROUBLE CODE CHART

HINT:

Parameters listed in the chart may not be exactly the same as your readings due to the type of instrument or other factors.

If a malfunction code is displayed during the DTC check in the check(test) mode, check the circuit for that code listed in the table below. For details of each code, refer to the See page under the respective "DTC No." in the DTC chart.

DTC No. (See page)	Detection Item	Trouble Area	*1 Check Engine Warning Light (Normal Mode/ Test Mode)	*2 Memory
12 (DI-26)	Engine speed Sensor Circuit Malfunction (TDC or G1 Circuit)	<ul style="list-style-type: none"> • Open or short in crankshaft position sensor circuit • Crankshaft position sensor • Engine ECU 	ON/ON	○
13 (DI-29)	Engine Speed Sensor Circuit Malfunction (NE Circuit)	<ul style="list-style-type: none"> • Open or short in engine speed sensor circuit • Engine speed sensor • Engine ECU 	ON/ON	○
14 (DI-31)	Timing Control System Malfunction	<ul style="list-style-type: none"> • Open or short in timing control valve circuit • Fuel filter (Clogging) • Fuel (Freezing, Air in) • Injection pump (Internal pressure and timing control valve) • Engine ECU 	ON/N.A.	○
15 (DI-34)	Throttle Control Motor Circuit Malfunction	<ul style="list-style-type: none"> • Open or short in throttle control motor circuit • Throttle control motor • Throttle valve • Throttle body • Engine ECU 	ON/N.A.	○
17	Interior IC Malfunction	<ul style="list-style-type: none"> • Engine ECU 	ON/N.A.	○
18 (DI-38)	Spill Control Valve Malfunction	<ul style="list-style-type: none"> • Open or short in spill control valve circuit • Spill control valve • Engine ECU 	ON/N.A.	○
19 (1) (DI-42)	Accelerator Pedal Position Sensor Circuit Malfunction (Open/Short)	<ul style="list-style-type: none"> • Open or short in accelerator pedal position sensor circuit • Accelerator pedal position sensor • Engine ECU 	ON/ON	○
19 (2) (DI-50)	Accelerator Pedal Position Sensor Circuit Malfunction (IDL Switch/Range)	<ul style="list-style-type: none"> • Open or short in accelerator pedal position sensor circuit • Accelerator pedal position sensor • Engine ECU 	ON/N.A.	○
19 (3) (DI-55)	Accelerator Pedal Closed Posi- tion Switch Circuit Malfunction (Short)	<ul style="list-style-type: none"> • Short in accelerator pedal closed position switch circuit • Accelerator pedal closed position switch • Engine ECU 	ON/N.A.	○
19 (4) (DI-55)	Accelerator Pedal Closed Posi- tion Switch Circuit Malfunction (Open)	<ul style="list-style-type: none"> • Open in accelerator pedal closed position switch circuit • Accelerator pedal closed position switch • Engine ECU 	ON/N.A.	○
22 (DI-57)	Water Temp. Sensor Circuit Malfunction	<ul style="list-style-type: none"> • Open or short in water temp. sensor circuit • Water temp. sensor • Engine ECU 	ON/ON	○
24 (DI-63)	Intake Air Temp. Sensor Circuit Malfunction	<ul style="list-style-type: none"> • Open or short in intake air temp. sensor circuit • Intake air temp. sensor • Engine ECU 	OFF/ON	○

DIAGNOSTICS - ENGINE

32 (DI-69)	Injection Pump Correction System Malfunction	<ul style="list-style-type: none"> • Open or short in injection pump correction unit circuit • Injection pump correction unit • Vacuum hose disconnected or clogged • Engine ECU 	OFF/N.A.	○
35 (DI-71)	Turbo Pressure Sensor Circuit Malfunction	<ul style="list-style-type: none"> • Open or short in turbo pressure sensor circuit • Turbo pressure sensor • Engine ECU 	ON/ON	○
39 (DI-78)	Fuel Temp. Sensor Circuit Malfunction	<ul style="list-style-type: none"> • Open or short in fuel temp. sensor circuit • Fuel temp. sensor • Engine ECU 	ON/ON	○
42 (DI-84)	Vehicle Speed Sensor Signal Circuit Malfunction	<ul style="list-style-type: none"> • Combination meter • Open or short in vehicle speed sensor circuit • Vehicle speed sensor • Engine ECU 	ON/ON	○
96 (DI-87)	EGR Valve Lift Sensor Circuit Malfunction	<ul style="list-style-type: none"> • Open or short in EGR valve lift sensor circuit • EGR valve lift sensor • Engine ECU 	ON/ON	○
99*3	Engine Immobilizer System Malfunction	<ul style="list-style-type: none"> • Open or short in engine immobilizer system circuit • Transponder key amplifier • Transponder key computer • Transponder key coil • Engine ECU 	OFF/N.A.	○

*1: "ON" displayed in the diagnosis mode column indicates that the check engine warning light is on when a malfunction is detected. "OFF" indicates that the "CHECK ENGINE" does not light up during the malfunction diagnosis, even if a malfunction is detected. "N.A." indicates that the item is not included in malfunction diagnosis.

*2: "○" in the memory column indicates that a diagnostic trouble code is recorded in the engine ECU memory when a malfunction occurs. Accordingly, on output of diagnostic results in the normal or test mode is done with the ignition switch ON.

*3: See Pub. No. RM789E (HILUX), RM663U (1999 4Runner) or RM805E (LAND CRUISER PRADO) on BE section.

PARTS LOCATION

Land Cruiser/Land Cruiser Prado, 4Runner

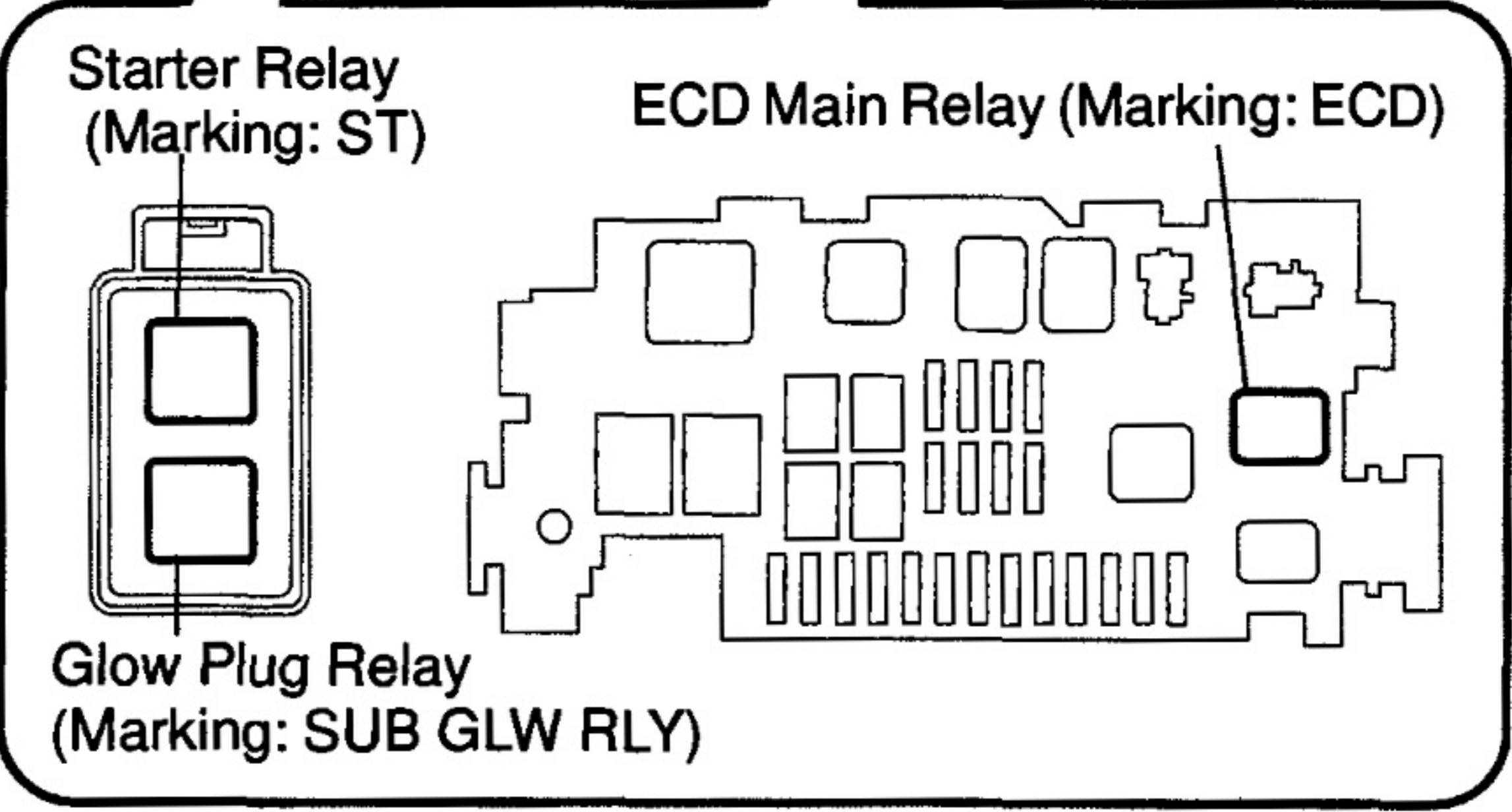
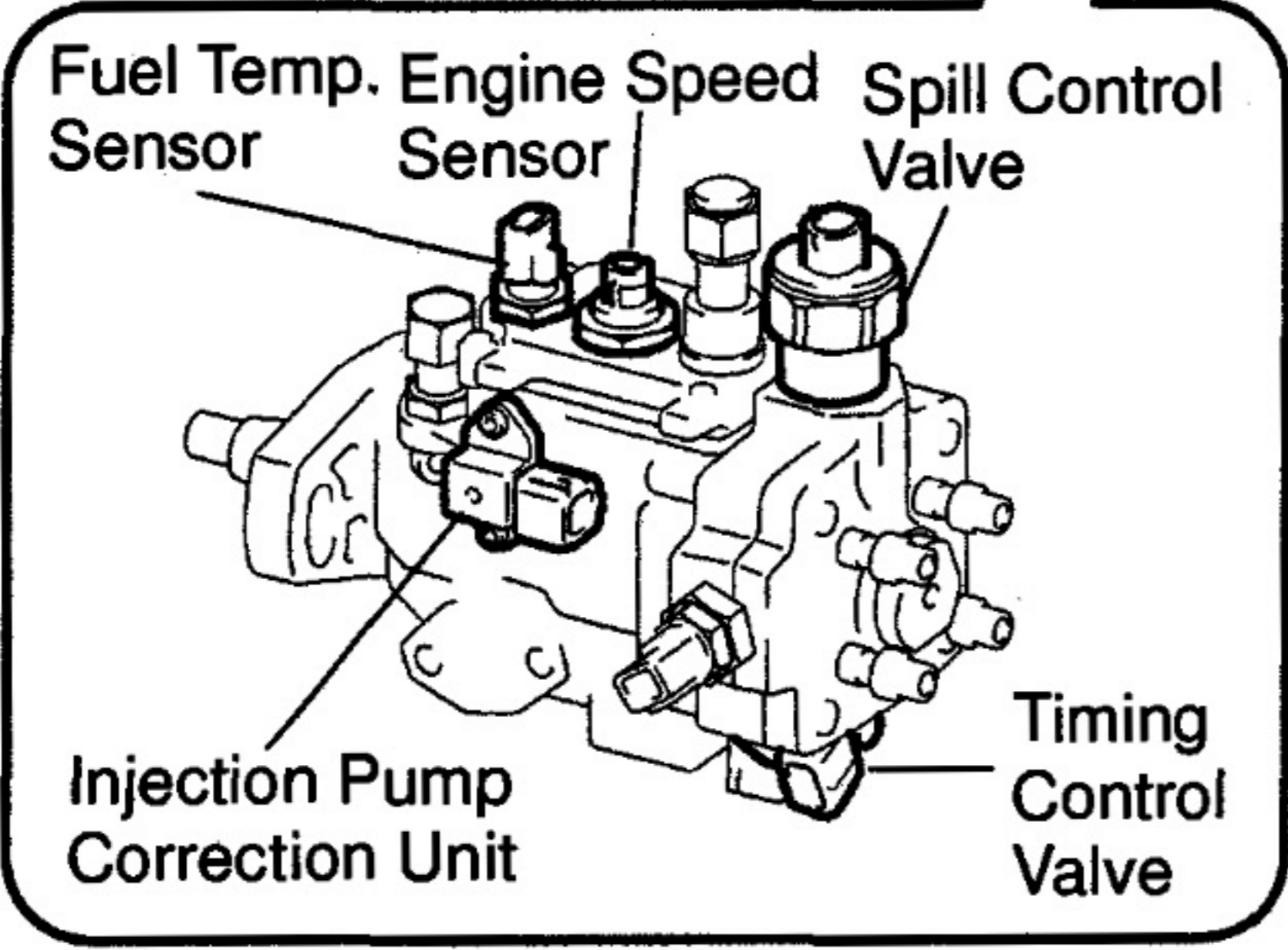
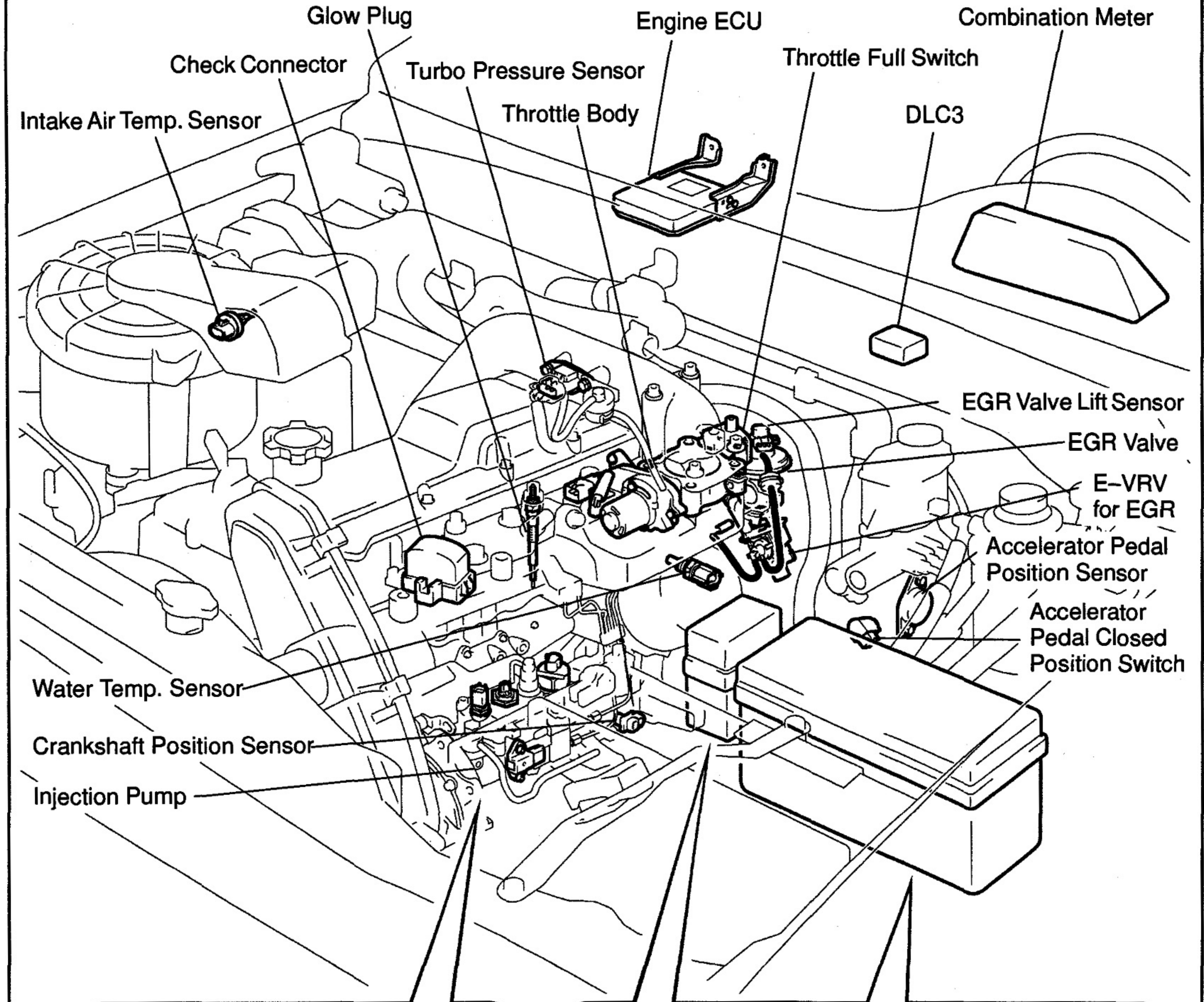

Hilux

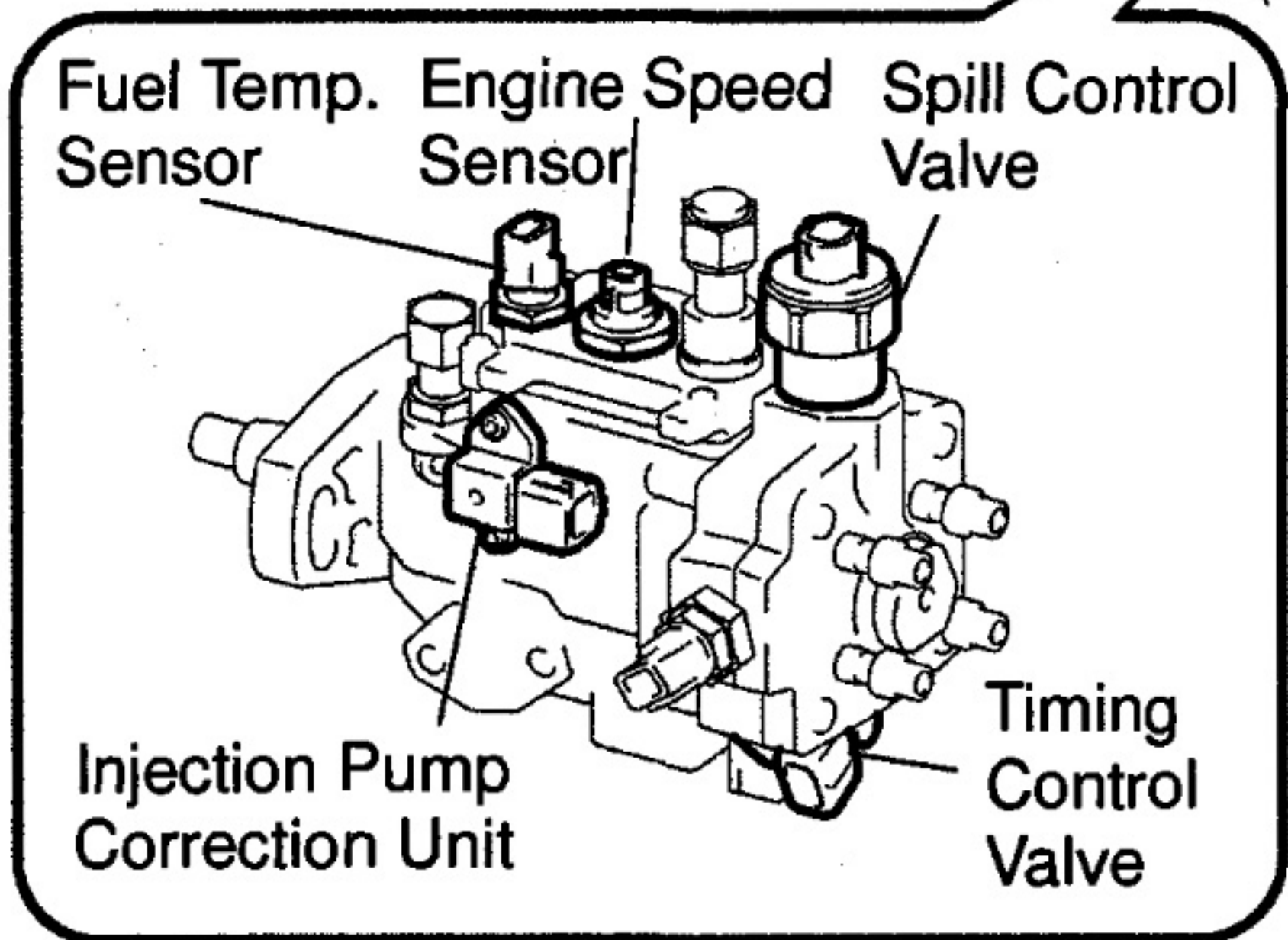
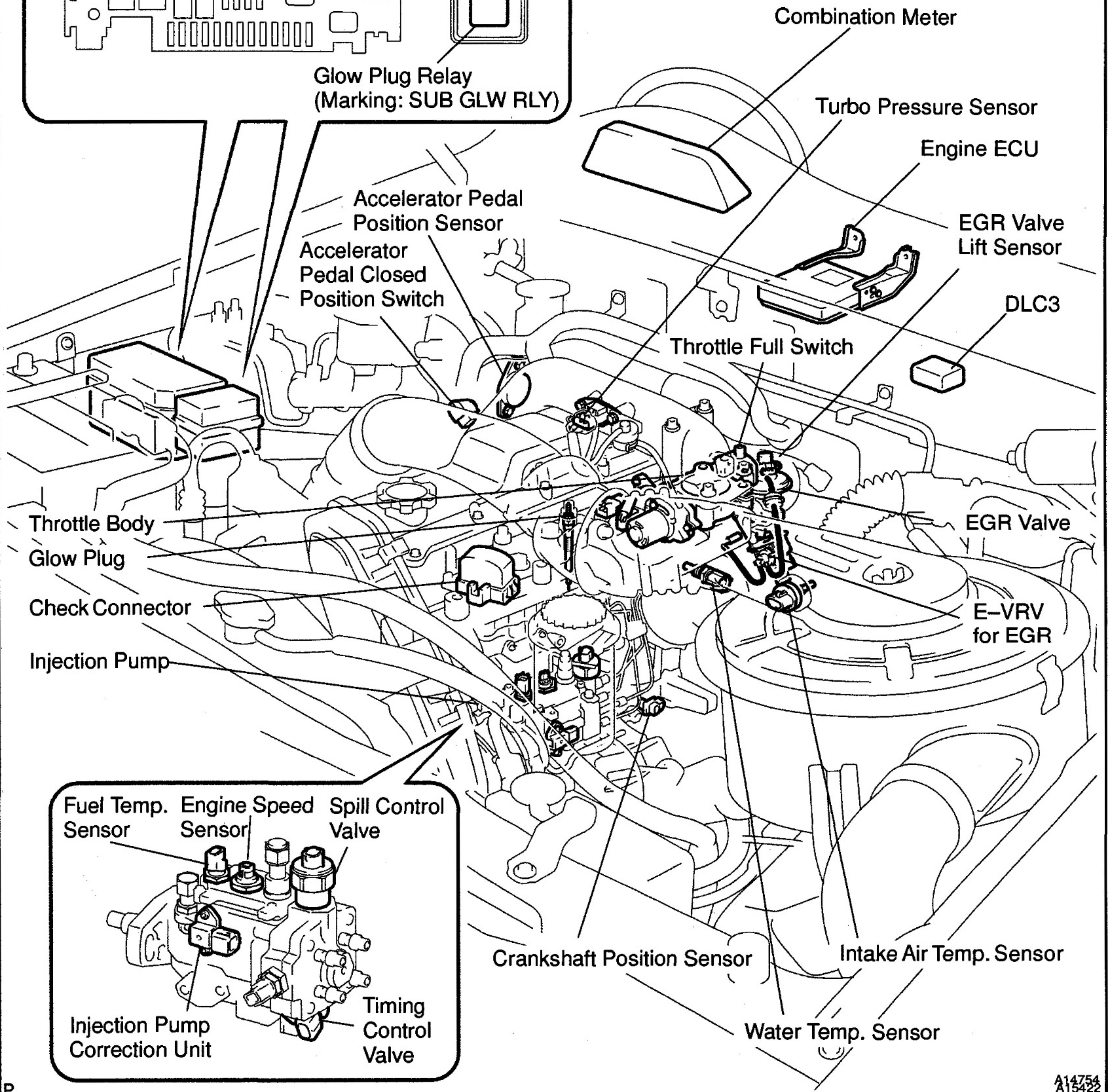
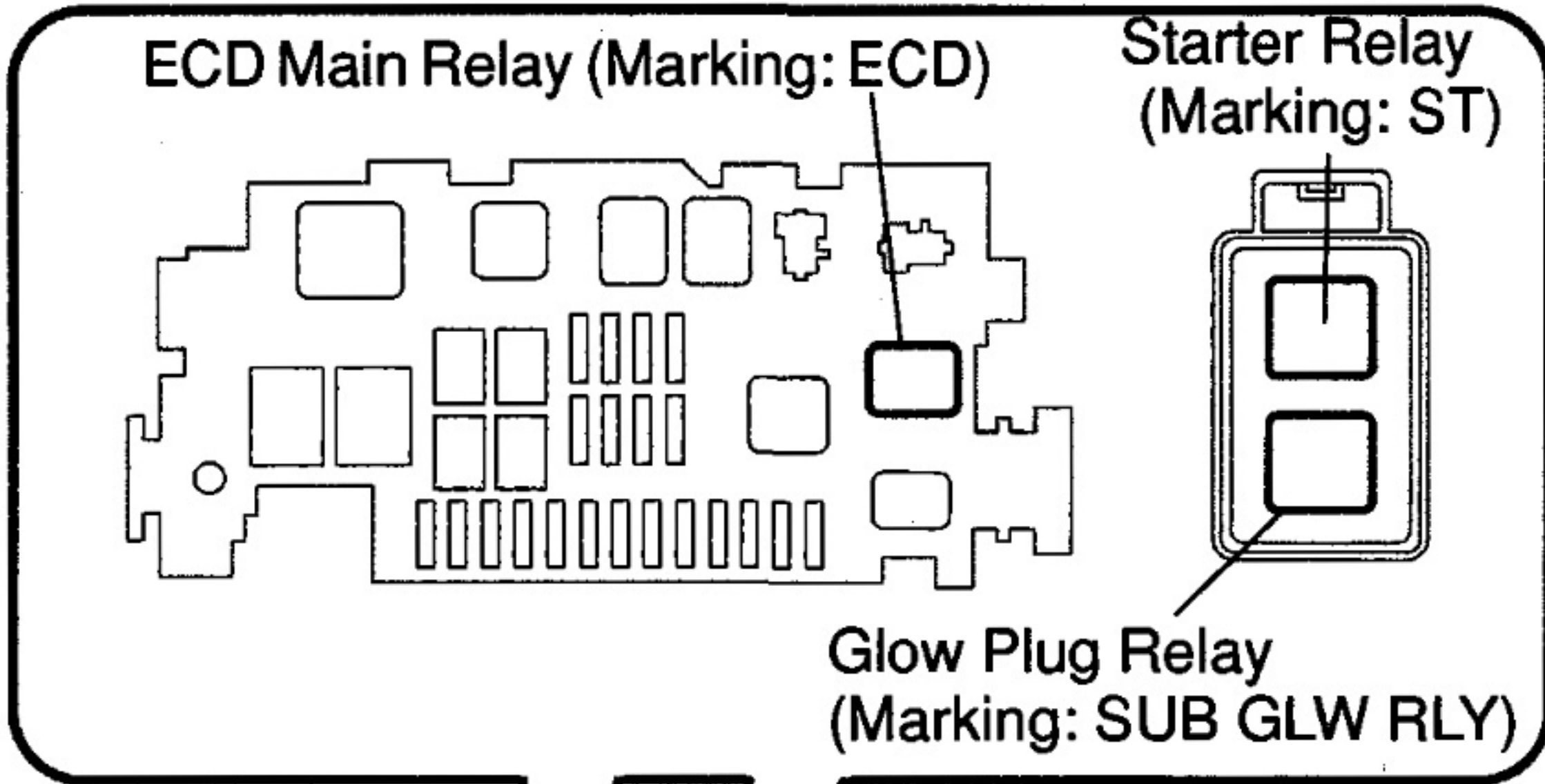

P

A14754
A15422

TERMINALS OF ECU

4Runner

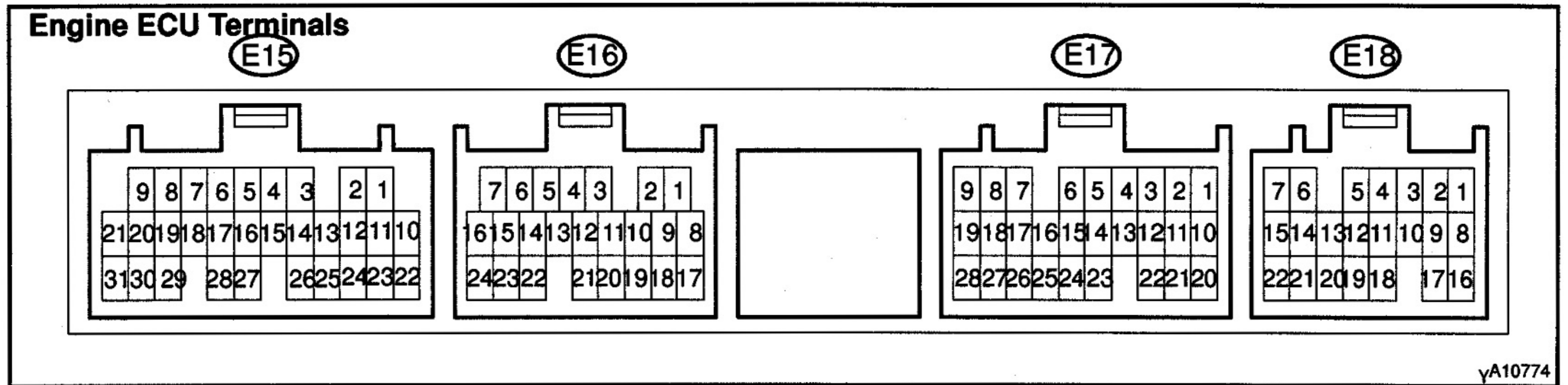

Symbols (Terminals No.)	Wiring Color	Condition	STD Voltage (V)
BATT (E18-2) - E1 (E15-22)	L-R - BR	Always	9 - 14
+ B (E18-9) - E1 (E15-22)	W-R - BR	IG switch ON	9 - 14
VC (E16-21) - E2 (E15-22)	L-B - R	IG switch ON	4.5 - 5.5
VCC (E17-8) - E2C (E17-27)	B-R - BR-B	IG switch ON	4.5 - 5.5
VA (E17-19) - E2C (E17-27)	Y-R - BR-B	Accelerator pedal fully closed	0.6 - 1.3
		Accelerator pedal fully opened	2.8 - 4.5
VAS (E17-28) - E2C (E17-27)	V-W - BR-B	Accelerator pedal fully closed	0.6 - 1.3
		Accelerator pedal fully opened	2.8 - 4.5
IDL (E17-18) - E2C (E17-27)	LG-R - BR-B	Accelerator pedal fully closed	9 - 14
		Accelerator pedal fully opened	0 - 3
PIM (E16-16) - E2 (E16-20)	B-Y - R	Apply vacuum 40 kPa (300 mmHg, 11.8 in.Hg)	1.0 - 1.8
		Apply vacuum 135 kPa (1,000 mmHg, 39.4 in.Hg)	2.3 - 4.2
THA (E16-22) - E2 (E16-20)	Y-G - R	Idling air intake temp. 0°C (32°F) to 60°C (140°F)	0.2 - 3.8
THW (E16-14) - E2 (E16-20)	G - R	Idling engine coolant temp. 60°C (140°F) to 120°C (248°F)	0.1 - 1.5
THF (E16-5) - E2 (E16-20)	W - R	IG switch ON (at engine cold)	0.5 - 3.8
STA (E17-24) - E1 (E15-22)	B-W - BR	Cranking	6.0 or more
TDC+ (E15-16) - TDC- (E15-27)	R - G	Idling	Pulse generation (See page DI-26)
NE+ (E15-17) - NE- (E15-28)	Y - L	Idling	Pulse generation (See page DI-26)
SP1 (E17-22) - E1 (E15-22)	G-O	IG switch ON Rotate driving wheel slowly	Pulse generation (See page DI-84)
TCV (E15-5) - E01 (E15-21)	G-W	IG switch ON	9 - 14
		Idling	Pulse generation (See page DI-31)
MREL (E18-7) - E01 (E15-21)	L-Y - W-B	IG switch ON	9 - 14
IGSW (E18-9) - E1 (E15-21)	GR-B - BR	IG switch ON	9 - 14
AC (E17-4) - E1 (E15-22)	L-Y - BR	A/C switch ON (at idling)	0 - 1.5
		A/C switch OFF	9 - 14
ACT (E17-13) - E1 (E15-22)	L-B - BR	IG switch ON	9 - 14
		At A/C cut controlled (Driving below 30 km/h, accelerator pedal fully opened for 5 sec.)	0 - 3
PDL (E17-9) - E1 (E15-22)	L-W - BR	Accelerator pedal fully closed	9 - 14
		Accelerator pedal fully opened	0 - 3

DIAGNOSTICS - ENGINE

TACH (E17-2) - E1 (E15-22)	LG - BR	Idling	Pulse generation
TC (E18-18) - E1 (E15-22)	GR - BR	IG switch ON	9 - 14
W (E18-12) - E1 (E15-22)	R-W - BR	Check engine warning light lights up	0 - 3
		Except check engine warning light lights up	9 - 14
GIND (E18-3) - E1 (E15-22)	BR - BR	Glow indicator light lights up	0 - 3
		Except glow indicator light lights up	9 - 14
DATA (E16-13) - E1 (E15-22)	V - BR	For 0.5 sec. after IG switch ON	Pulse generation
CLK (E16-12) - E1 (E15-22)	P - BR	For 0.5 sec. after IG switch ON	Pulse generation
SIL (E18-19) - E1 (E18-22)	W - BR	Connect hand-held tester to DLC3	Pulse generation
IMI (E19-17) - E1 (E18-22)	L-B - BR	Idling	Pulse generation
IMO (E19-6) - E1 (E18-22)	L-R - BR	A few sec. after engine starting	Pulse generation

Hilux

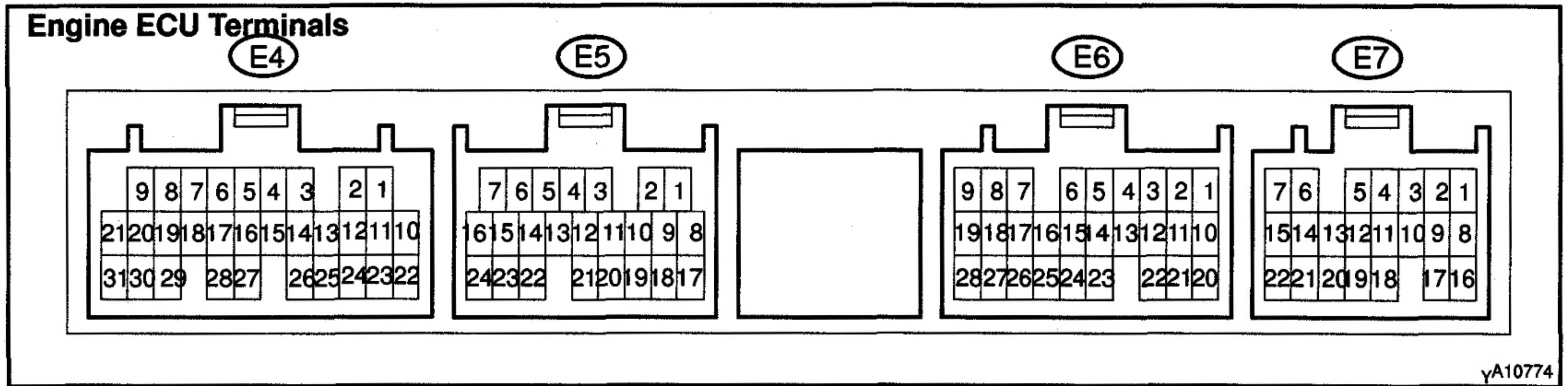

Symbols (Terminals No.)	Wiring Color	Condition	STD Voltage (V)
BATT (E7-2) - E1 (E4-22)	Y - BR	Always	9 - 14
+ B (E7-9) - E1 (E4-22)	R - L - BR	IG switch ON	9 - 14
VC (E5-21) - E2 (E4-22)	B - G - R	IG switch ON	4.5 - 5.5
VCC (E6-8) - E2C (E6-27)	R - W - LG	IG switch ON	4.5 - 5.5
VA (E6-19) - E2C (E6-27)	B - L - LG	Accelerator pedal fully closed	0.6 - 1.3
		Accelerator pedal fully opened	2.8 - 4.5
VAS (E6-28) - E2C (E6-27)	P - LG	Accelerator pedal fully closed	0.6 - 1.3
		Accelerator pedal fully opened	2.8 - 4.5
IDL (E6-18) - E2C (E6-27)	B - R - LG	Accelerator pedal fully closed	9 - 14
		Accelerator pedal fully opened	0 - 3
PIM (E5-16) - E2 (E5-20)	B - Y - G - R	Apply vacuum 40 kPa (300 mmHg, 11.8 in.Hg)	1.0 - 1.8
		Apply vacuum 135 kPa (1,000 mmHg, 39.4 in.Hg)	2.3 - 4.2
THA (E5-22) - E2 (E5-20)	P - L - BR - W	Idling air intake temp. 0°C (32°F) to 60°C (140°F)	0.2 - 3.8
THW (E5-14) - E2 (E5-20)	P - BR - W	Idling engine coolant temp. 60°C (140°F) to 120°C (248°F)	0.1 - 1.5
THF (E5-5) - E2 (E5-20)	LG - B	IG switch ON (at engine cold)	0.5 - 3.8
STA (E6-24) - E1 (E4-22)	V - Y - BR	Cranking	6.0 or more
TDC+ (E4-16) - TDC- (E4-27)	R - G	Idling	Pulse generation (See page DI-26)
NE+ (E4-17) - NE- (E4-28)	W - B	Idling	Pulse generation (See page DI-26)
SP1 (E6-22) - E1 (E4-22)	G - O - BR	IG switch ON Rotate driving wheel slowly	Pulse generation
TCV (E4-5) - E01 (E5-21)	G - B - W - B	IG switch ON	9 - 14
		Idling	Pulse generation (See page DI-31)
EGR (E4-4) - E01 (E4-21)	G - W - W - B	IG switch ON	9 - 14
		EGR ON	Pulse generation (See page DI-109)
MREL (E7-7) - E01 (E4-21)	L - O - W - B	IG switch ON	9 - 14
IGSW (E7-9) - E1 (E4-21)	B - W - BR	IG switch ON	9 - 14
AC1 (E6-4) - E1 (E4-22)	Y - BR	A/C switch ON (at idling)	0 - 1.5
		A/C switch OFF	9 - 14
ACT (E6-13) - E1 (E4-22)	LG - R - BR	IG switch ON	9 - 14
		At A/C cut controlled (Driving below 30 km/h, accelerator pedal fully opened for 5 sec.)	0 - 3

DIAGNOSTICS - ENGINE

PDL (E6-9) - E1 (E4-22)	L - BR	Accelerator pedal fully closed	9 - 14
		Accelerator pedal fully opened	0 - 3
TAC (E6-2) - E1 (E4-22)	B - BR	Idling	Pulse generation
TC (E7-18) - E1 (E4-22)	V - BR	IG switch ON	9 - 14
W (E7-12) - E1 (E4-22)	P - BR	Check engine warning light lights up	0 - 3
		Except check engine warning light lights up	9 - 14
G-IND (E7-3) - E1 (E4-22)	R-W - BR	Glow indicator light lights up	0 - 3
		Except glow indicator light lights up	9 - 14
DATA (E5-13) - E1 (E4-22)	V - BR	For 0.5 sec. after IG switch ON	Pulse generation
CLK (E5-12) - E1 (E4-22)	P - BR	For 0.5 sec. after IG switch ON	Pulse generation
FSW (E6-7) - E1 (E4-22)	R-L - BR	At shift position in first position	9 - 14
		At other shift position in first position	0 - 3
SIL (E7-19) - E1 (E4-22)	V-W - BR	Connect hand-held tester to DLC3	Pulse generation
IMI (E7-17) - E1 (E4-22)	L-B - BR	Idling	Pulse generation
IMO (E7-6) - E1 (E4-22)	L-R - BR	A few sec. after engine starting	Pulse generation

Land Cruiser/Land Cruiser Prado

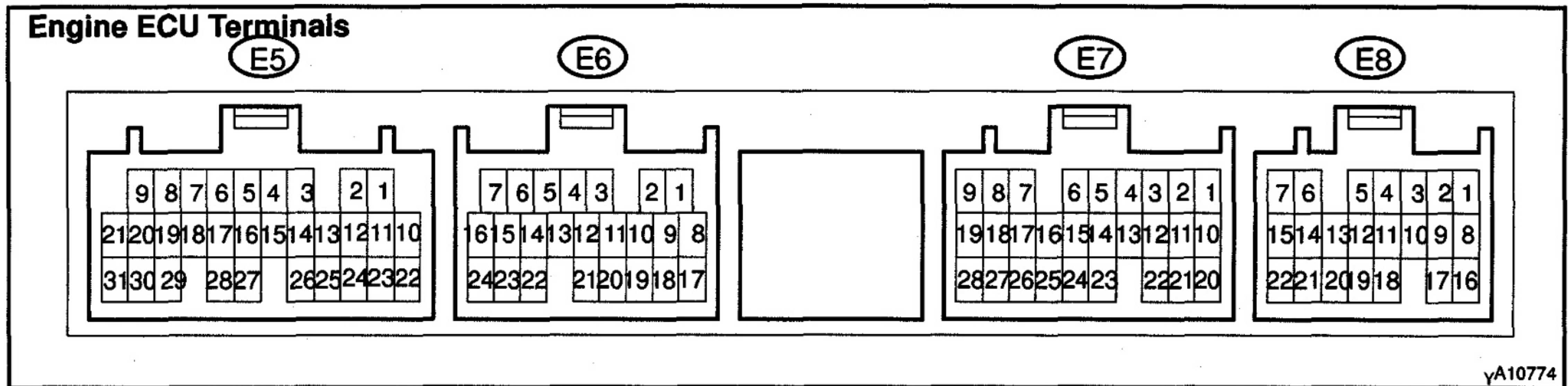

Symbols (Terminals No.)	Wiring Color	Condition	STD Voltage (V)
BATT (E8-2) - E1 (E5-22)	B-R - BR	Always	9 - 14
+ B (E8-9) - E1 (E5-22)	B-Y - BR	IG switch ON	9 - 14
VC (E6-21) - E2 (E5-22)	L-R - BR-W	IG switch ON	4.5 - 5.5
VCC (E7-8) - E2C (E7-27)	L-R - BR-W	IG switch ON	4.5 - 5.5
VA (E7-19) - E2C (E7-27)	R-Y - BR-W	Accelerator pedal fully closed	0.6 - 1.3
		Accelerator pedal fully opened	2.8 - 4.5
VAS (E7-28) - E2C (E7-27)	P-L - BR-W	Accelerator pedal fully closed	0.6 - 1.3
		Accelerator pedal fully opened	2.8 - 4.5
IDL (E7-18) - E2C (E7-27)	LG-B - BR-W	Accelerator pedal fully closed	9 - 14
		Accelerator pedal fully opened	0 - 3
PIM (E6-16) - E2 (E6-20)	P-L - BR-W	Apply vacuum 40 kPa (300 mmHg, 11.8 in.Hg)	1.0 - 1.8
		Apply vacuum 135 kPa (1,000 mmHg, 39.4 in.Hg)	2.3 - 4.2
THA (E6-22) - E2 (E6-20)	W-G - BR-W	Idling Air intake temp. 0°C (32°F) to 60°C (140°F)	0.2 - 3.8
THW (E6-14) - E2 (E6-20)	G-B - BR-W	Idling Engine coolant temp. 60°C (140°F) to 120°C (248°F)	0.1 - 1.5
THF (E6-5) - E2 (E6-20)	B-R - BR-W	IG switch ON (at engine cold)	0.5 - 3.8
STA (E7-24) - E1 (E5-22)	B-W - BR	Cranking	6.0 or more
TDC+ (E5-16) - TDC- (E5-27)	B - W	Idling	Pulse generation (See page DI-26)
NE+ (E5-17) - NE- (E5-28)	L - G	Idling	Pulse generation (See page DI-26)
SP1 (E7-22) - E1 (E5-22)	V - BR	IG switch ON Rotate driving wheel slowly	Pulse generation
TCV (E5-5) - E01 (E5-21)	R-Y - W-B	IG switch ON	9 - 14
		Idling	Pulse generation (See page DI-31)
EGR (E7-24) - E01 (E7-13)	R-G - W-B	EGR ON	Pulse generation (See page DI-109)
S/TH (E7-10) - E01 (E7-13)	W-L - W-B	VSV OFF at idling	9 - 14
		VSV ON (after IG switch OFF for 2 sec.)	0 - 3
PA (E7-9) - E01 (E7-13)	W-R - W-B	VSV for atmospheric pressure leaning OFF	9 - 14
		VSV for atmospheric pressure leaning ON	0 - 3
MREL (E8-7) - E01 (E5-21)	B-W - W-B	IG switch ON	9 - 14
IGSW (E1-9) - E1 (E5-21)	B-R - BR	IG switch ON	9 - 14
AC (E7-4) - E1 (E5-22)	W-G - BR	A/C switch ON at idling	0 - 1.5
		A/C switch OFF	9 - 14

DIAGNOSTICS - ENGINE

ACT (E7-13) - E1 (E5-22)	L-B - BR	IG switch ON	9 - 14
		At A/C cut controlled (Driving below 30 km/h, accelerator pedal fully opened for 5 sec.)	0 - 3
PDL (E7-9) - E1 (E5-22)	GR - BR	Accelerator pedal fully closed	9 - 14
		Accelerator pedal fully opened	0 - 3
TAC (E7-2) - E1 (E5-22)	B - BR	Idling	Pulse generation
TC (E8-18) - E1 (E5-22)	P-B - BR	IG switch ON	9 - 14
W (E8-12) - E1 (E5-22)	W - BR	Check engine warning light lights up	0 - 3
		Except check engine warning light lights up	9 - 14
G-IND (E8-3) - E1 (E5-22)	Y-R - BR	Glow indicator light lights up	0 - 3
		Except glow indicator light lights up	9 - 14
DATA (E6-13) - E1 (E5-22)	G-B - BR	For 0.5 sec. after IG switch ON	Pulse generation
CLK (E6-12) - E1 (E5-22)	G-W - BR	For 0.5 sec. after IG switch ON	Pulse generation
EGRC (E7-3) - E1 (E5-22)	R - BR	IG switch ON	0 - 3
		Maintain engine speed at 1500 rpm after warming up	9 - 14
IREL (E9-2) - E1 (E5-22)	G-Y - BR	IG switch ON	0 - 3
		At intake heater ON	9 - 14
VCH (E7-23) - E1 (E5-22)	Y-R - BR	Heater blower switch ON	0 - 3
		Heater blower switch OFF	9 - 14
SVR (E9-13) - E1 (E5-22)	L-W - BR	IG switch ON	0 - 1.5
VCT (E6-7) - E1 (E5-22)	L-B - BR	Heater blower switch ON	0 - 3
		Heater blower switch OFF	9 - 14
HSW (E9-20) - E1 (E5-22)	B-L - BR	Push on power heater switch	0 - 3
		Push off power heater switch	9 - 14
FSW (E7-7) - E1 (E5-22)	R-L - BR	At shift position in first position	9 - 14
		At other shift position in first position	0 - 3
PS (E7-9) - E1 (E8-22)	P - BR	Idling Turn steering wheel	0 - 3
		IG switch ON	9 - 14
SIL (E8-19) - E1 (E8-22)	V-W - BR	Connect hand-held tester to DLC3	Pulse generation
IMI (E9-17) - E1 (E8-22)	L-B - BR	Idling	Pulse generation
IMO (E9-6) - E1 (E8-22)	L-R - BR	A few sec. after engine starting	Pulse generation

PROBLEM SYMPTOMS TABLE

When the malfunction code is not confirmed the DTC check and the problem still can not be confirmed in the basic inspection, then proceed to this step and perform a troubleshooting according to the numbered order given in the table below.

Symptom	Suspect Area	See page
Does not crank (Difficult to start)	<ol style="list-style-type: none"> 1. Starter 2. Starter relay 3. Neutral start switch circuit (A/T) 	# # -
Cold engine (Difficult to start)	<ol style="list-style-type: none"> 1. STA signal circuit 2. Injection nozzle 3. Fuel filter 4. Engine ECU 5. Injection pump 	DI-104 FU-3 # # FU-5
Hot engine (Difficult to start)	<ol style="list-style-type: none"> 1. STA signal circuit 2. Injection nozzle 3. Fuel filter 4. Compression 5. Engine ECU 6. Injection pump 	DI-104 FU-3 # # # FU-5
Soon after starting (Engine stall)	<ol style="list-style-type: none"> 1. Fuel filter 2. ECU power source circuit 3. Engine ECU 4. Injection pump 	# DI-92 # FU-5
Others (Engine stall)	<ol style="list-style-type: none"> 1. ECU power source circuit 2. Engine ECU 3. Injection pump 	DI-92 # FU-5
Incorrect first idle (Poor idling)	<ol style="list-style-type: none"> 1. Fuel filter 2. Engine ECU 3. Injection pump 	# # FU-5
High engine idle speed (Poor idling)	<ol style="list-style-type: none"> 1. A/C signal circuit 2. STA signal circuit 3. Engine ECU 4. Injection pump 	DI-125 DI-104 # FU-5
Lower engine idle speed (Poor idling)	<ol style="list-style-type: none"> 1. A/C signal circuit 2. Injection nozzle 3. EGR control circuit 4. Compression 5. Valve clearance 6. Fuel line (Air bead) 7. Engine ECU 8. Injection pump 	DI-125 FU-3 DI-109 # # - # FU-5
Rough idling (Poor idling)	<ol style="list-style-type: none"> 1. Injection nozzle 2. Fuel line (Air bead) 3. EGR control circuit 4. Compression 5. Valve clearance 6. Engine ECU 7. Injection pump 	FU-3 - DI-109 # # # FU-5

DIAGNOSTICS - ENGINE

Hunting at hot engine (Poor idling)	<ol style="list-style-type: none"> 1. Injection nozzle 2. ECU power source circuit 3. Compression 4. Fuel line (Air bead) 5. Valve clearance 6. Engine ECU 7. Injection pump 	FU-3 DI-92 # - # # FU-5
Hunting at cold engine (Poor idling)	<ol style="list-style-type: none"> 1. Injection nozzle 2. ECU power source circuit 3. Compression 4. Fuel line (Air bead) 5. Valve clearance 6. Engine ECU 7. Injection pump 	FU-3 DI-92 # - # # FU-5
Hesitation/ Poor acceleration (Poor driveability)	<ol style="list-style-type: none"> 1. Injection nozzle 2. Fuel filter 3. EGR control circuit 4. Compression 5. Engine ECU 6. Injection pump 	FU-3 # DI-109 # # FU-5
Knocking (Poor driveability)	<ol style="list-style-type: none"> 1. Injection nozzle 2. EGR control circuit 3. Engine ECU 	FU-3 DI-109 #
Black smoke (Poor driveability)	<ol style="list-style-type: none"> 1. Injection nozzle 2. EGR control circuit 3. Engine ECU 4. Injection pump 	FU-3 DI-109 # FU-5
White smoke (Poor driveability)	<ol style="list-style-type: none"> 1. EGR control circuit 2. Injection nozzle 3. Fuel filter 4. Engine ECU 5. Injection pump 	DI-109 FU-3 # # FU-5
Surging/ Hunting (Poor driveability)	<ol style="list-style-type: none"> 1. Injection nozzle 2. Engine ECU 3. Injection pump 	FU-3 # FU-5

#: See Pub. No. RM710E (1KZ-TE), RM789E (Hilux Sup.), RM663U (1999 4Runner) or RM805E (Land Cruiser/Land Cruiser Prado Sup.).

CIRCUIT INSPECTION

DTC	12	Crankshaft Position Sensor Circuit Malfunction
------------	-----------	---

CIRCUIT DESCRIPTION

The crankshaft position sensor in the Engine Control System contains a signal plate and a pickup coil for a TDC signal. The TDC signal plate has 1 tooth on its outer circumference. The TDC signal sensor generates 1 signal for every engine revolution. The engine ECU detects the top dead center by the TDC signals.

The engine speed sensor in the Engine Control System contains a signal plate and a pickup coil for a NE signal. The NE signal plate has 78 teeth and is mounted in the injection pump. The NE signal sensor generates 78 signals of 2 engine revolutions. The engine ECU detects the engine speed and cam lift position of the injection pump. The engine ECU uses TDC signal and NE signals for injection timing control. And NE signal is used for injection volume control, too.

DTC No.	DTC Detection Condition	Trouble Area
12	No TDC signal to engine ECU at 400 rpm or more	<ul style="list-style-type: none"> • Open or short in crankshaft position sensor circuit • Crankshaft position sensor • Engine ECU

WIRING DIAGRAM

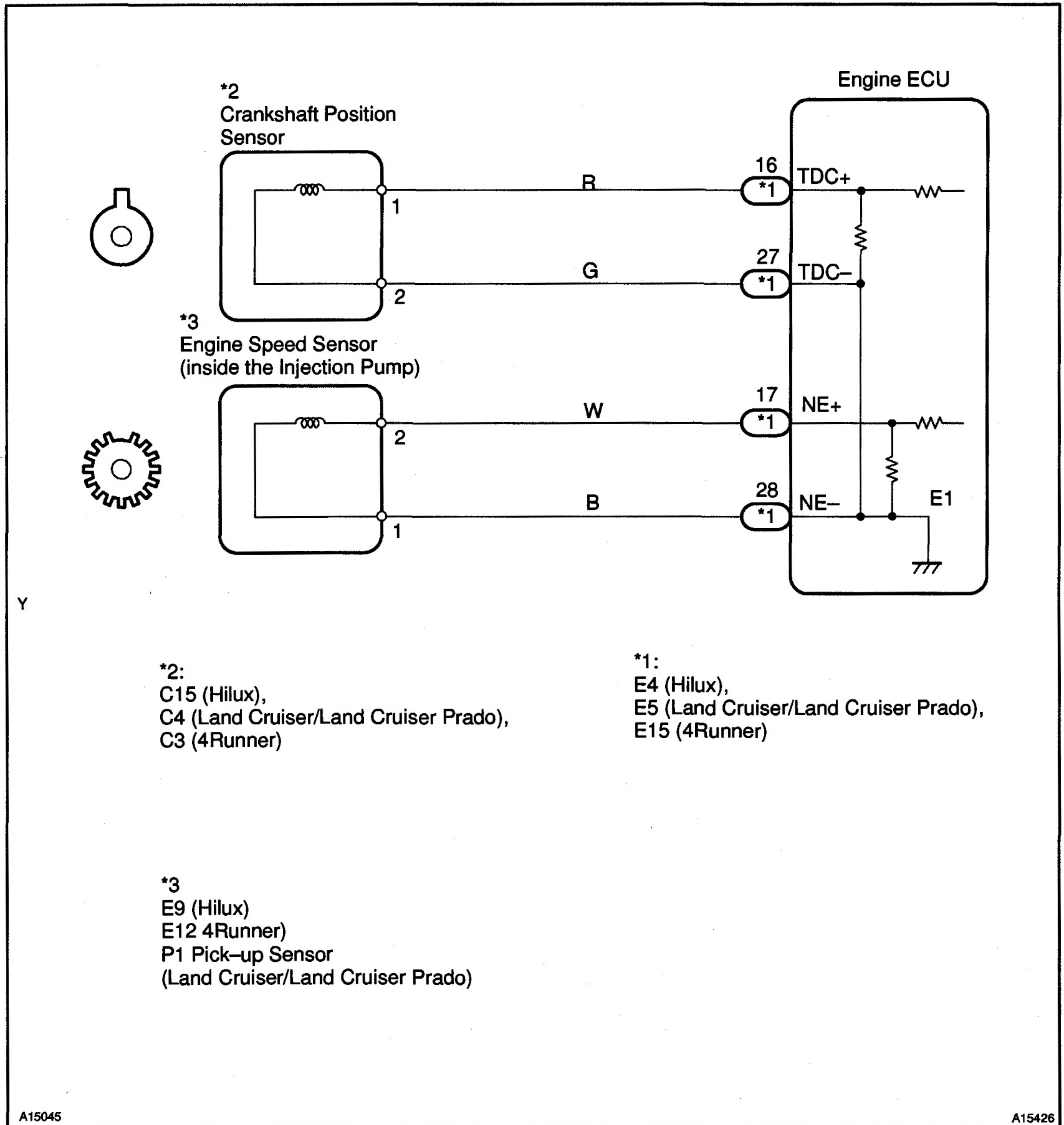

INSPECTION PROCEDURE

HINT:

Read freeze frame data using hand-held tester, as freeze frame data records the engine conditions when a malfunction is detected. When troubleshooting, it is useful for determining whether the vehicle was running or stopped, the engine was warmed up or not, the air-fuel ratio was lean or rich, etc. at the time of the malfunction.

- 1 Check resistance of crankshaft position sensor (TDC) (See Pub. No. RM710E, ED section).**

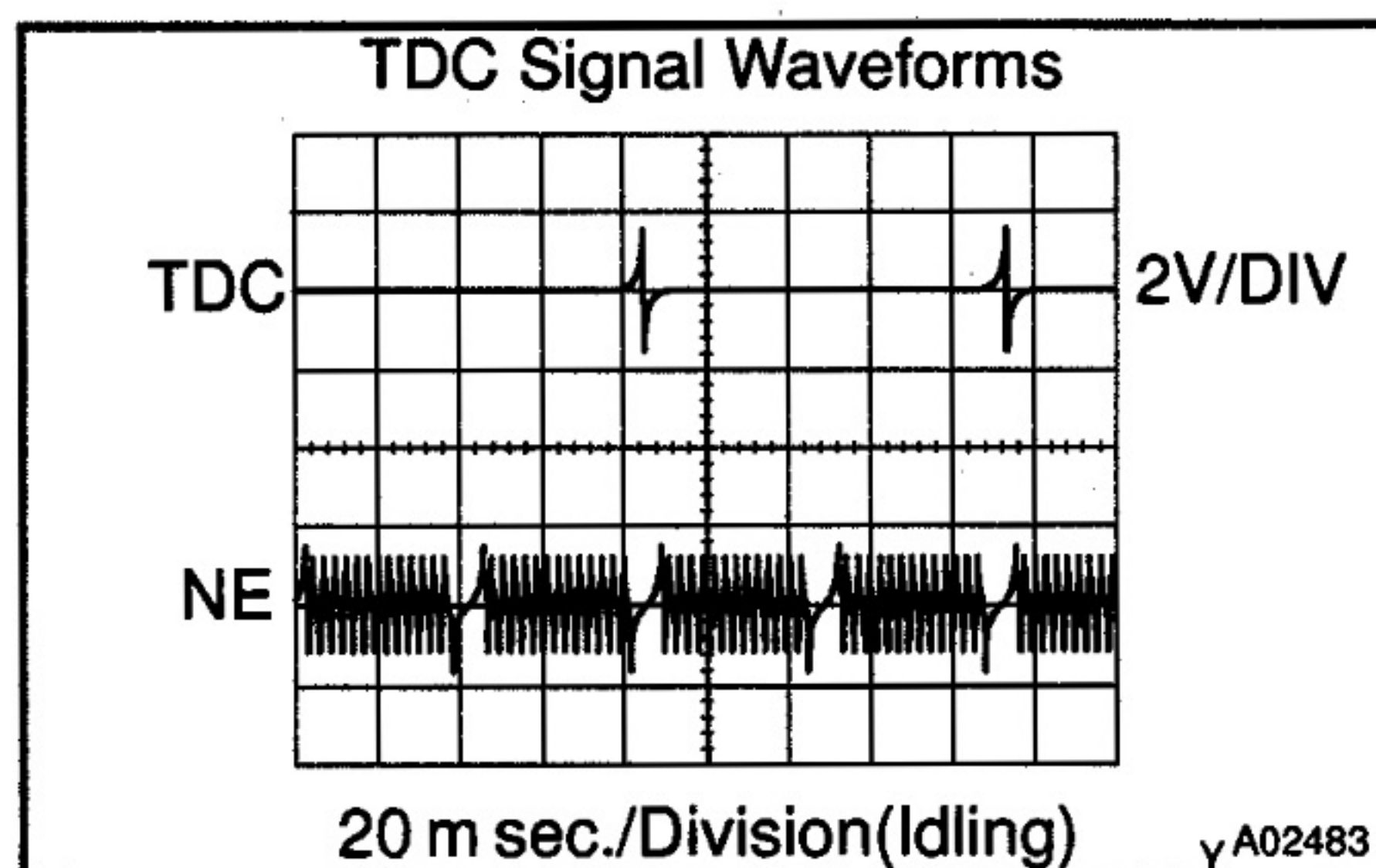

Reference: INSPECTION USING OSCILLOSCOPE

During cranking or idling, check the waveforms between terminals TDC+ and TDC-, and NE+ and NE- of the engine ECU connector.

HINT:

The correct waveforms are as shown.

NG

Replace crankshaft position sensor.

OK

- 2 Check for open and short in harness and connector between engine ECU and crankshaft position sensor (See page IN-20).**

NG

Repair or replace harness or connector.

OK

- 3 Inspection sensor installation.**

NG

Tighten sensor.

OK

Check and replace engine ECU (See page IN-20).

DTC	13	Engine Speed Sensor Circuit Malfunction (NECircuit)
------------	-----------	--

CIRCUIT DESCRIPTION

Refer to DTC12 on page DI-26.

DTC No.	DTC Detection Condition	Trouble Area
13	No NE signal to engine ECU for 0.5 sec. or more at 580 rpm or more	<ul style="list-style-type: none"> • Open or short in engine speed sensor circuit • Engine speed sensor • Engine ECU
	No NE signal to engine ECU for 2.0 sec. or more during cranking	

WIRING DIAGRAM

Refer to DTC12 on page DI-26.

INSPECTION PROCEDURE

HINT:

Read freeze frame data using hand-held tester, as freeze frame data records the engine conditions when a malfunction is detected. When troubleshooting, it is useful for determining whether the vehicle was running or stopped, the engine was warmed up or not, the air-fuel ratio was lean or rich, etc. at the time of the malfunction.

1	Check resistance of engine speed sensor (See Pub. No. RM710E, ED section).
----------	---

NG

Replace injection pump (See page FU-5).

OK

2	Check for open and short in harness and connector between engine ECU and engine speed sensor (See page IN-20).
----------	---

NG

Repair or replace harness or connector.

OK

3	Inspect sensor installation.
----------	-------------------------------------

NG

Tighten sensor.



Check and replace engine ECU (See page IN-20).

DTC	14	Timing Control System Malfunction
------------	-----------	--

CIRCUIT DESCRIPTION

The engine ECU controls the injection timing by actuating the timing control valve. The timing control valve is mounted on the injection pump and delay one by duty control of pump internal fuel pressure. The engine ECU detects the injection advance angle by TDC and NE signals.

DTC No.	DTC Detection Condition	Trouble Area
14	After engine warmed up and during, actual injection timing is different from target value of engine ECU calculated for several sec.	<ul style="list-style-type: none"> • Open or short in timing control valve circuit • Timing control valve • Fuel filter (Clogging) • Fuel (Freezing, Air in) • Injection pump (Internal pressure and timing control valve) • Engine ECU

WIRING DIAGRAM

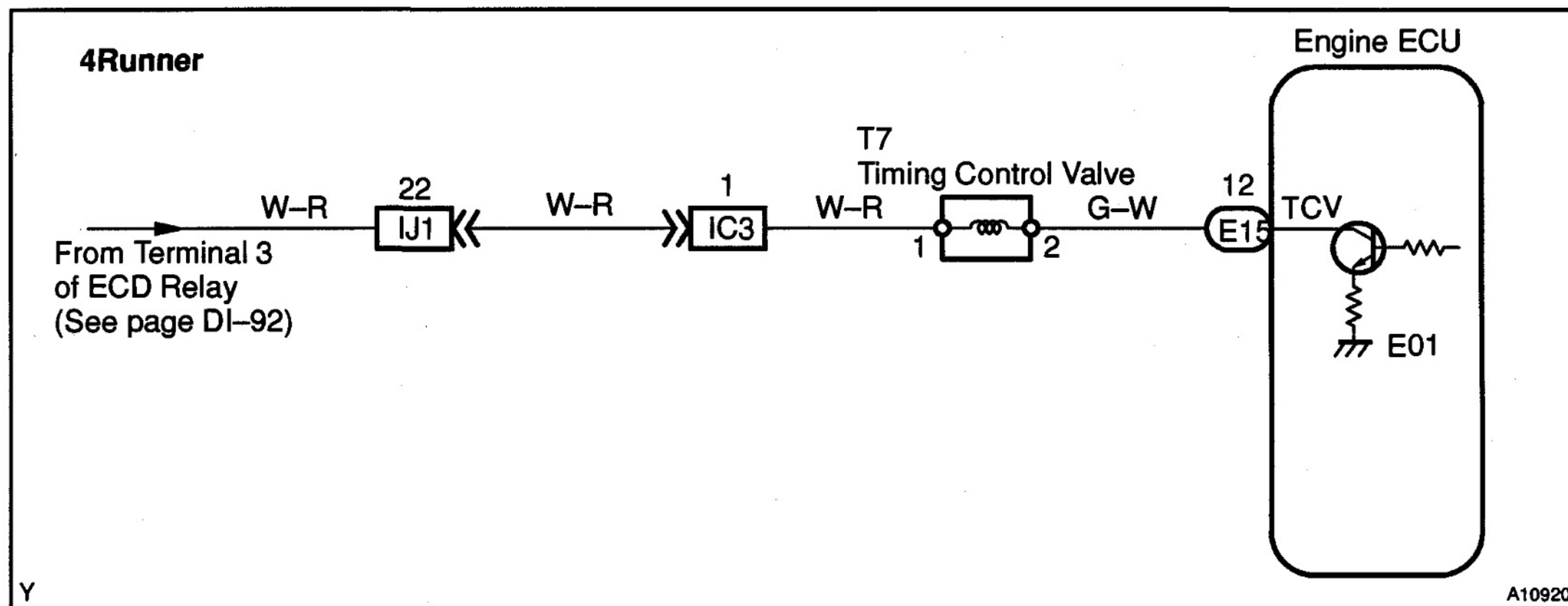
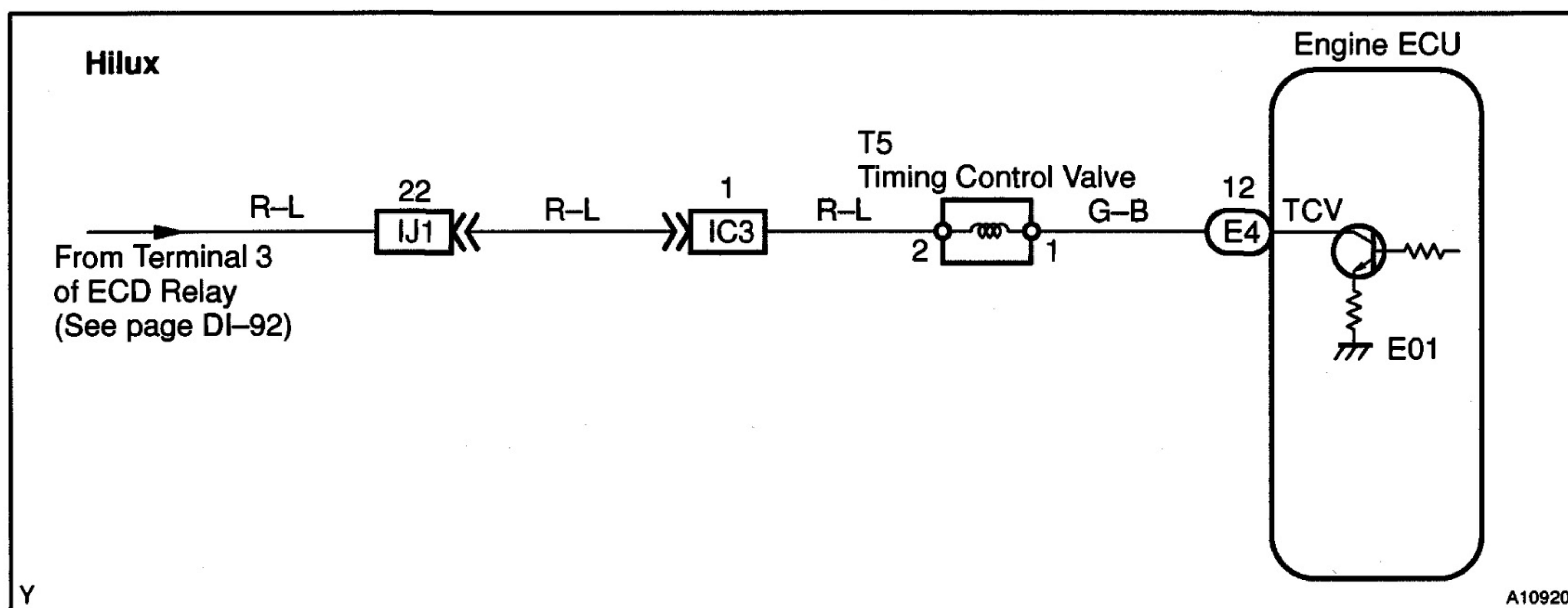

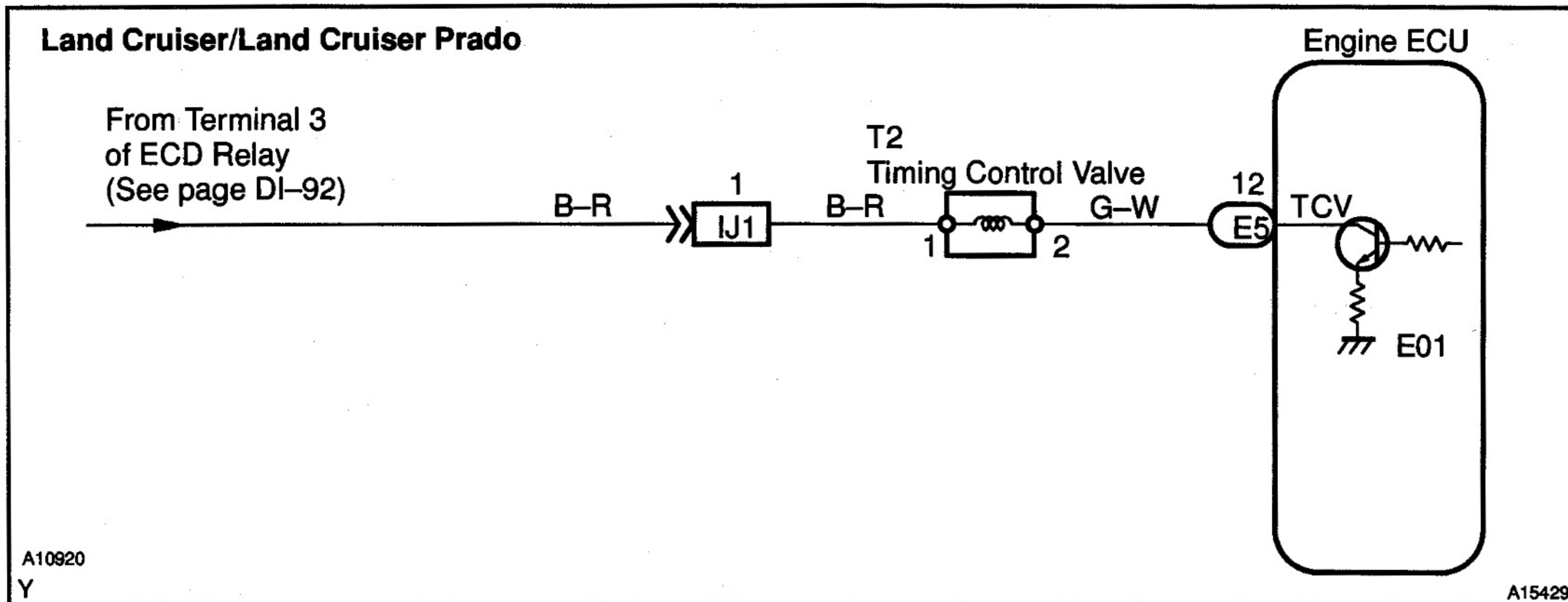

INSPECTION PROCEDURE

HINT:

Read freeze frame data using hand-held tester, as freeze frame data records the engine conditions when a malfunction is detected. When troubleshooting, it is useful for determining whether the vehicle was running or stopped, the engine was warmed up or not, the air-fuel ratio was lean or rich, etc. at the time of the malfunction.

1	Check timing control valve (See page FU-5).
----------	--

NG

Replace timing control valve.

OK

2	Check voltage between terminal TCV of engine ECU connector and body ground.
----------	--

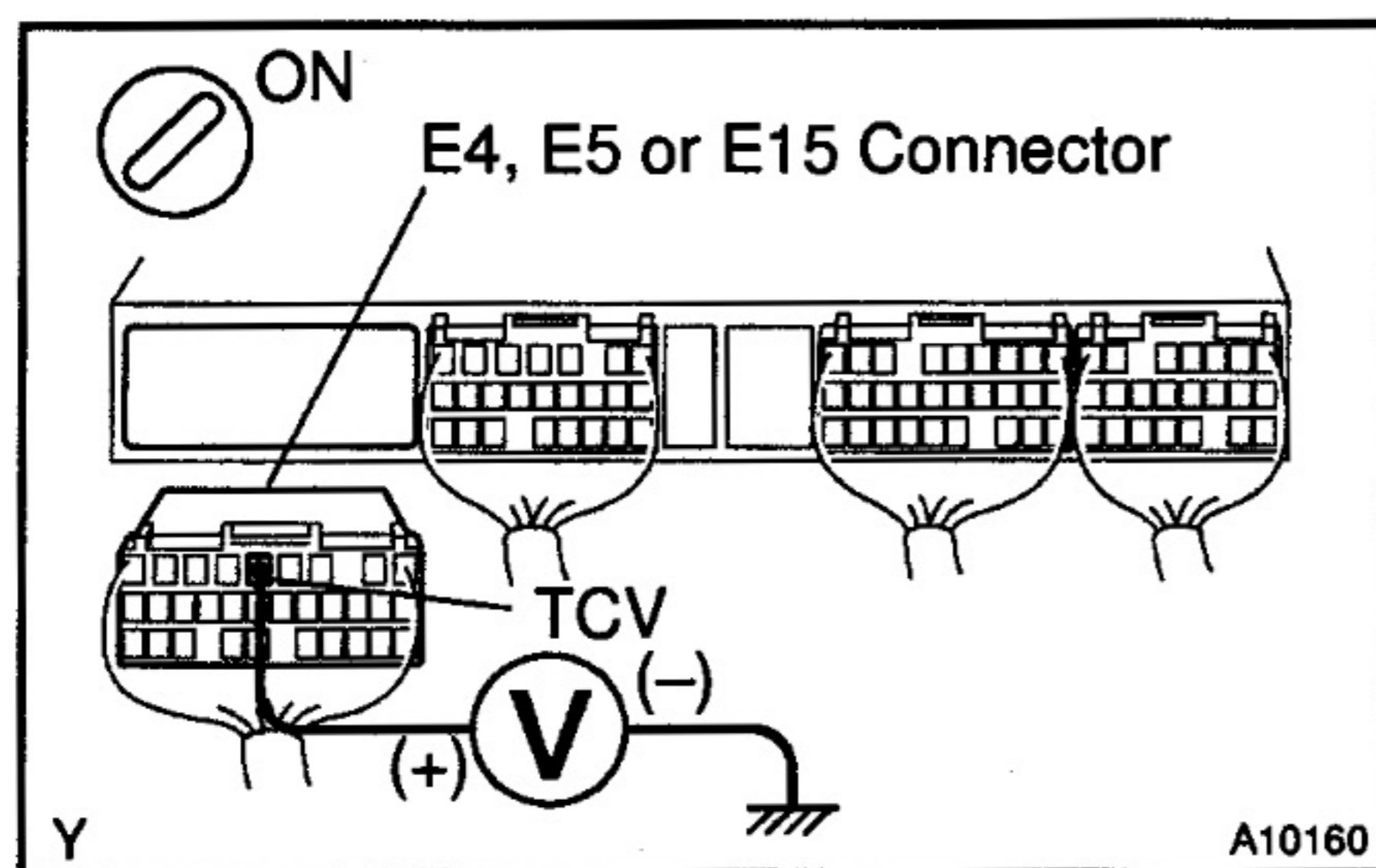

PREPARATION:

- Remove the glove compartment door.
- Disconnect the E4 (Hilux), E5 (Land Cruiser/Land Cruiser Prado) or E15 (4Runner) connector of the engine ECU.
- Turn the ignition switch ON.

CHECK:

Measure the voltage between terminal TCV of the engine ECU connector and the body ground.

OK:

Voltage: 9 - 14 V

OK

Go to step 3.

NG

Check for open or short in harness and connector between timing control valve and engine ECU, and timing control valve and ECD main relay (Marking: ECD) (See page IN-20).

3 Check voltage between terminal TCV of engine ECU connector and body ground.

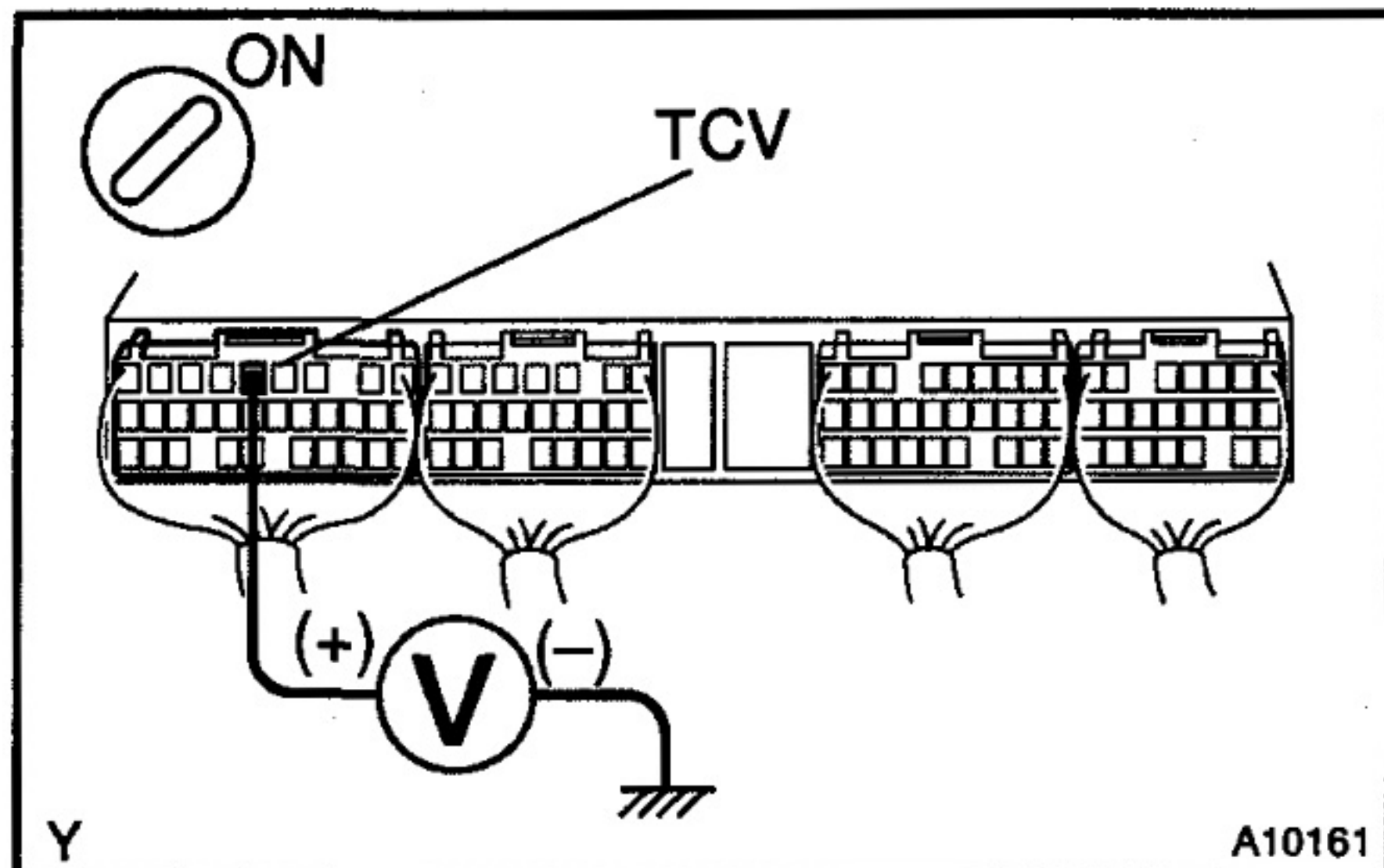

PREPARATION:

- (a) Remove the glove compartment door.
- (b) Turn the ignition switch ON.

CHECK:

Measure the voltage between terminal TCV of the engine ECU connector and the body ground.

OK:

Voltage: 9 – 14 V

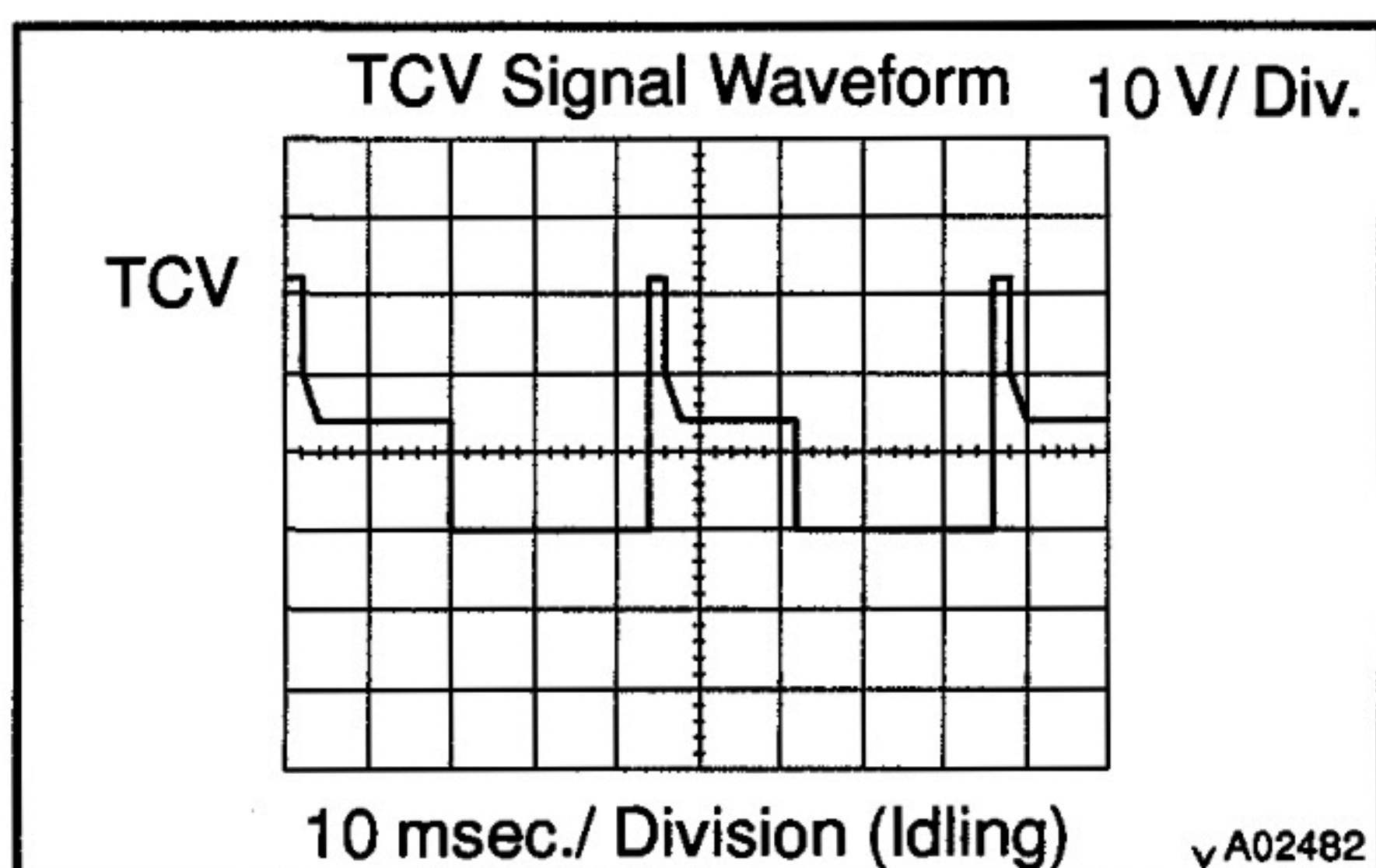

Reference: INSPECTION USING OSCILLOSCOPE

During idling, check the waveform between terminals TCV and E1 of the engine ECU connector.

HINT:

The correct waveform is as shown.

NG

Check and replace engine ECU (See page IN-20).

OK

4 Check fuel filter being clogged, fuel freezing and fuel air in.

NG

Replace or repair.

OK

Check and replace injection pump (See page FU-5).

DTC	15	Throttle Control Motor Circuit Malfunction
------------	-----------	---

CIRCUIT DESCRIPTION

Throttle control motor is operated by the engine ECU and it opens and closes the throttle valve. The fully opening of the throttle valve is detected by the throttle fully open position switch which is mounted on the throttle body.

If this DTC is stored, the engine ECU cuts the power for the throttle control motor.

DTC No.	DTC Detection Condition	Trouble Area
15	Open or short in throttle control motor circuit	<ul style="list-style-type: none"> • Open or short in throttle control motor circuit • Throttle control motor • Throttle valve
	Open or short in throttle full switch circuit	<ul style="list-style-type: none"> • Throttle body • Engine ECU

WIRING DIAGRAM

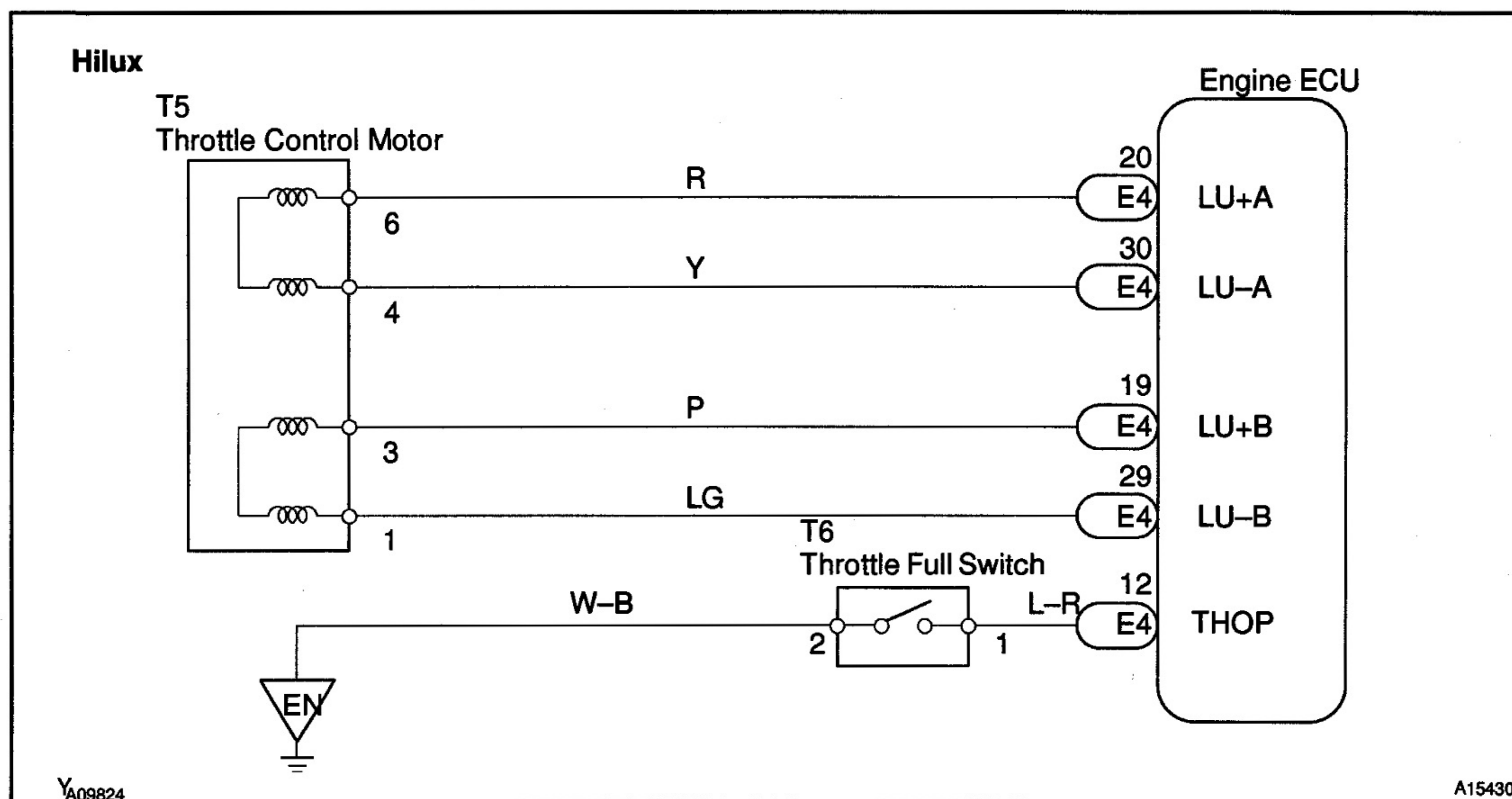

4Runner

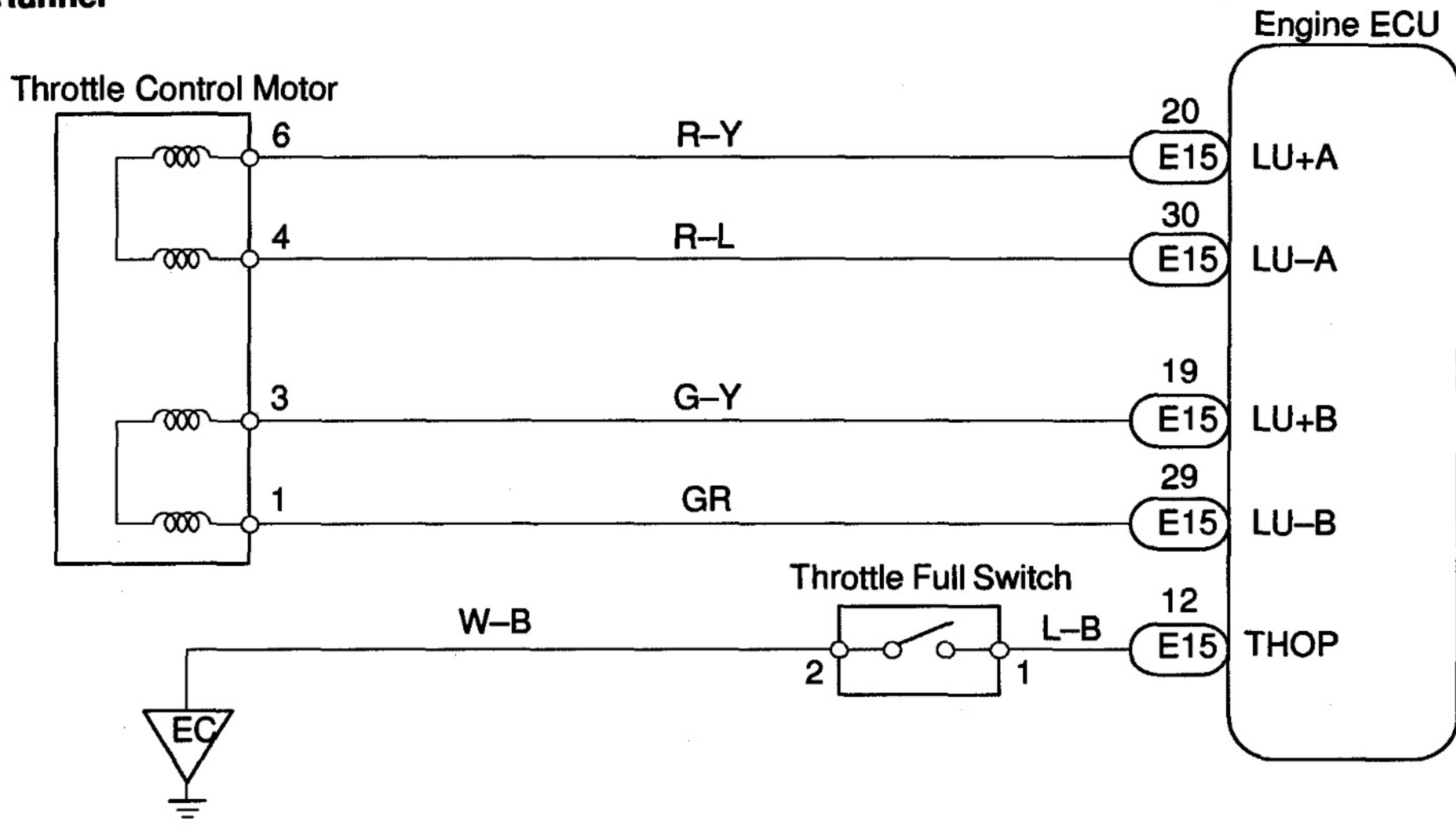

Y09824

A15430

Land Cruiser/Land Cruiser Prado

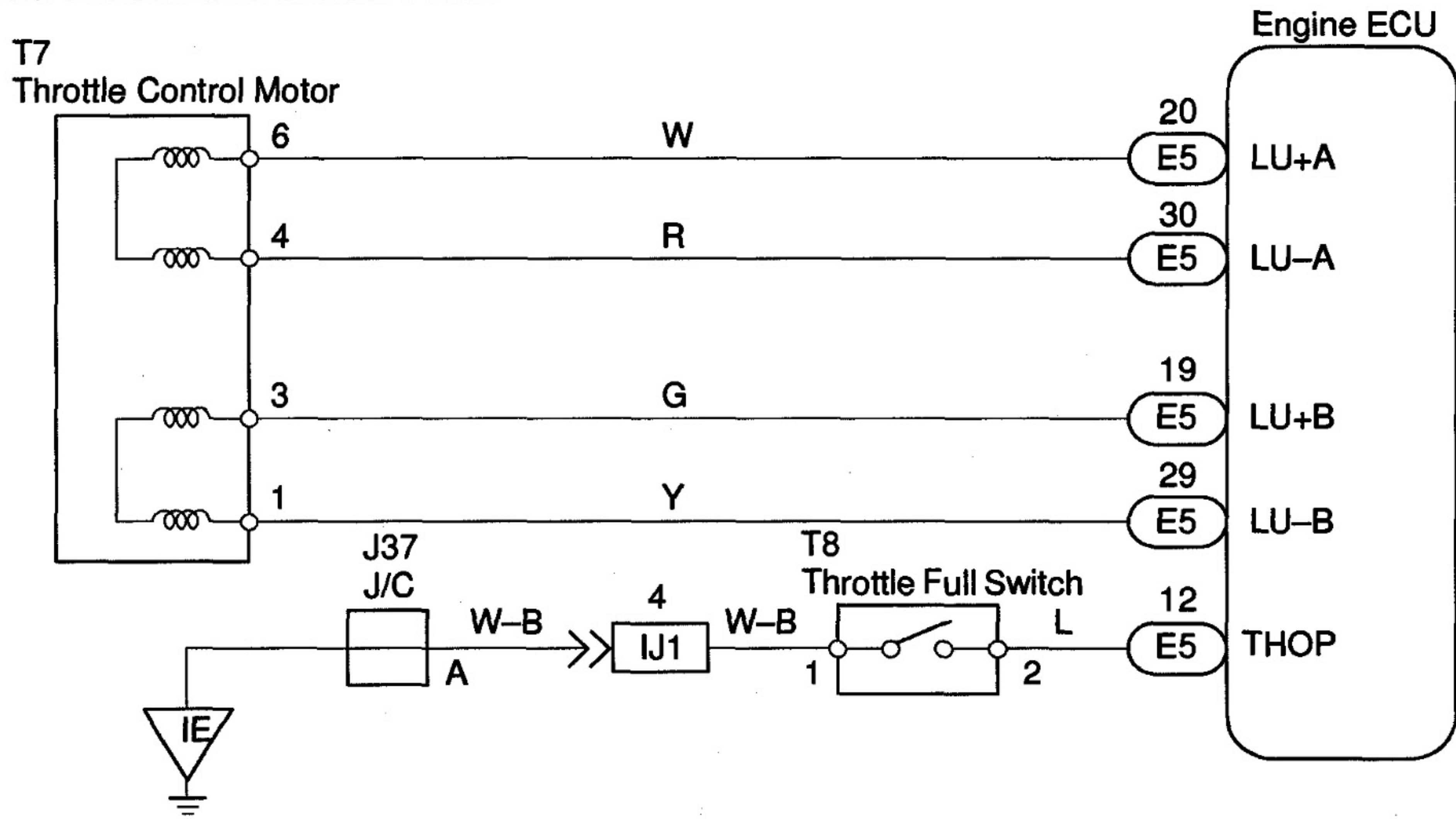

Y

A09824

INSPECTION PROCEDURE

HINT:

Read freeze frame data using hand-held tester, as freeze frame data records the engine conditions when a malfunction is detected. When troubleshooting, it is useful for determining whether the vehicle was running or stopped, the engine was warmed up or not, the air-fuel ratio was lean or rich, etc. at the time of the malfunction.

1 Check throttle control motor circuit.

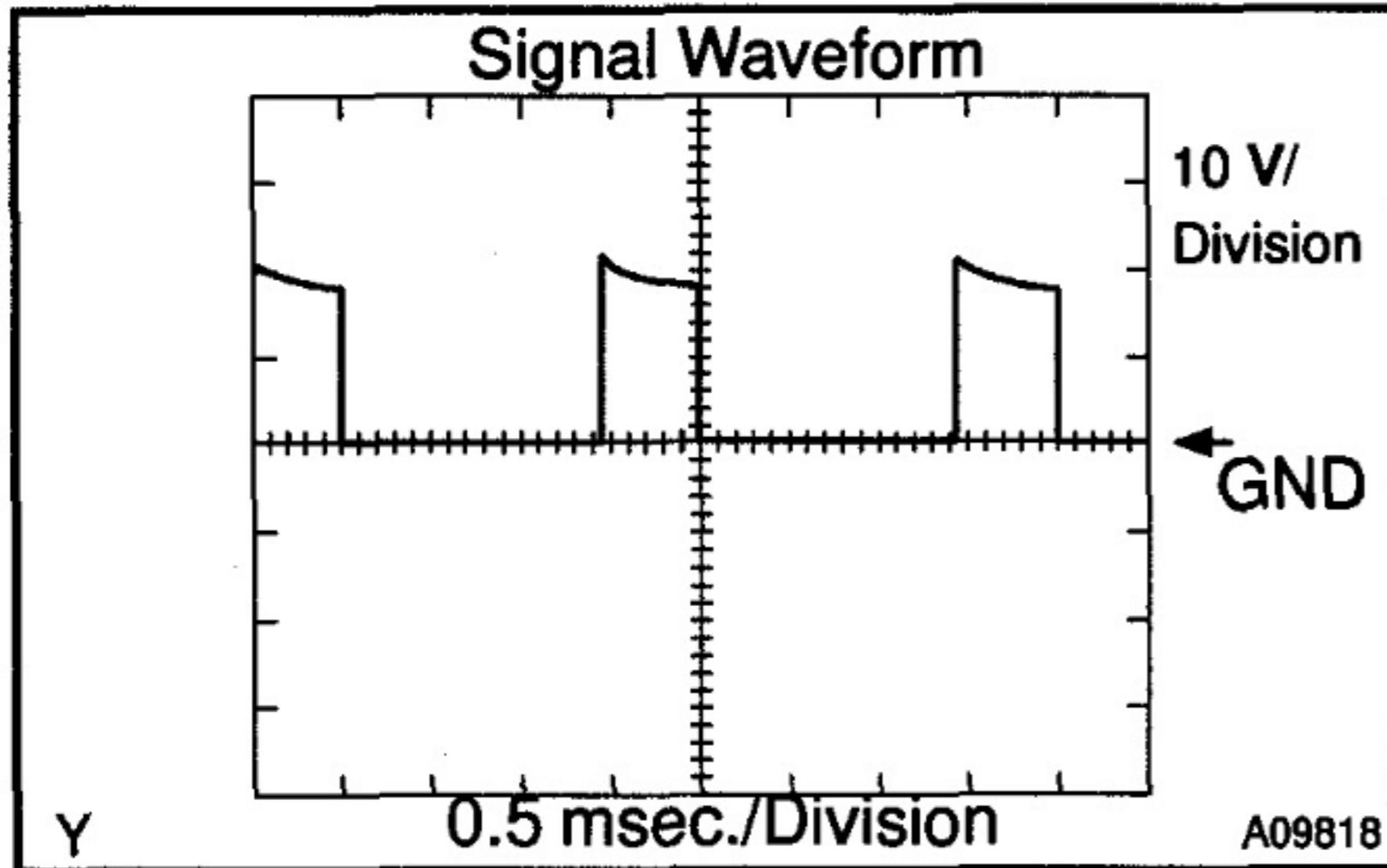

PREPARATION:

- Connect the oscilloscope between terminals LU+A/LU-A/LU+B/LU-B and E01 of the engine ECU connector.
- Start the engine.

CHECK:

Check the waveform between terminals LU+A/LU-A/LU+B/LU-B and E01 of the engine ECU connector when the engine is racing.

OK:

The correct waveform is as shown.

OK

Check and replace engine ECU (See page IN-20).

NG

2 Check throttle control motor.

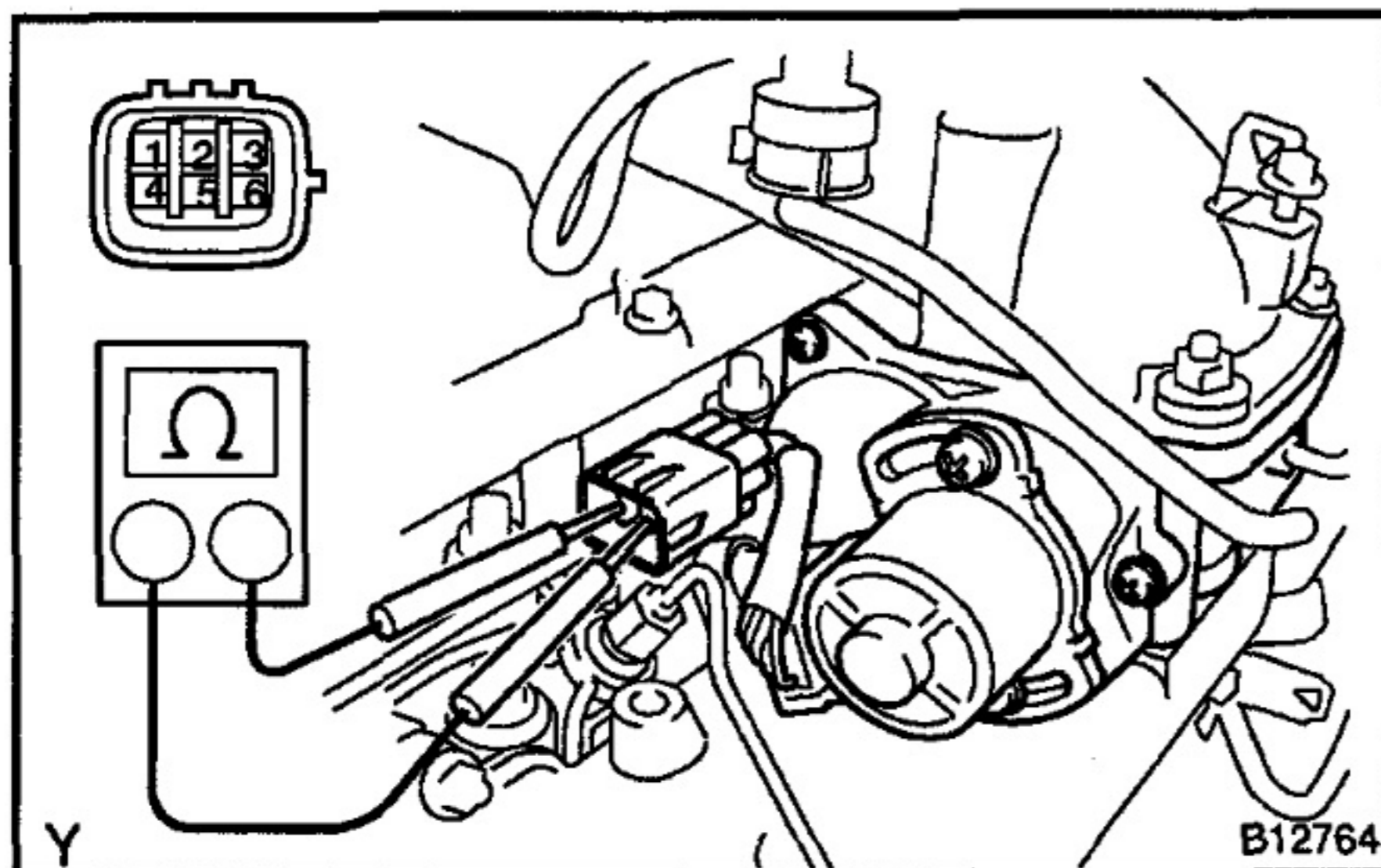

PREPARATION:

Disconnect the throttle control motor connector.

CHECK:

- Measure the resistance between terminals 2 and 1/3 of the throttle control motor.
- Measure the resistance between terminals 5 and 4/6 of the throttle control motor.

OK:

Resistance: 18 – 22 Ω at 20°C (68°F)

NG

Replace throttle body assembly (See page ED-1).

OK

3 Check for open and short in harness and connector between throttle control motor and engine ECU (See page IN-20).

NG

Repair or replace harness or connector.

OK

Check and replace engine ECU.

DTC	18	Spill Control Valve Circuit
------------	-----------	------------------------------------

CIRCUIT DESCRIPTION

The engine ECU controls the fuel injection volume by operating the spill control valve. The spill control valve is mounted on the injection pump, and open or close the injection pressure releasing port by the solenoid valve in the spill control valve (During injection; valve is close (ON)). The engine ECU decides the basic fuel injection volume by the engine rpm and throttle valve opening angle, and calculates the final fuel injection angle to add the various corrections on the basic fuel injection volume. The engine ECU counts the NE pulse to detect the angle from the time when the injection starts and operates the spill control valve from ON to OFF (The injection pressure releasing port is open.) at the position where the final fuel injection angle.

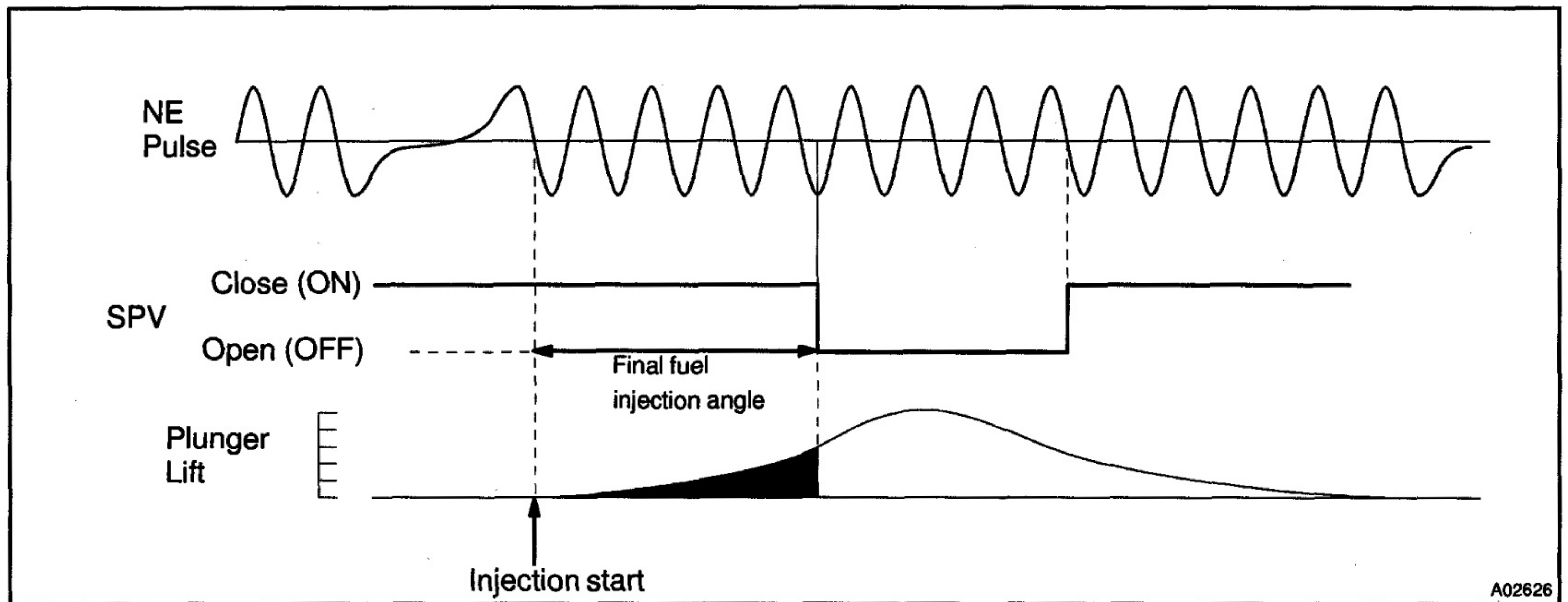

A02626

DTC No.	DTC Detection Condition	Trouble Area
18	Open or short in spill control valve circuit	<ul style="list-style-type: none"> • Open or short in spill control valve circuit • Spill control valve • Engine ECU

WIRING DIAGRAM

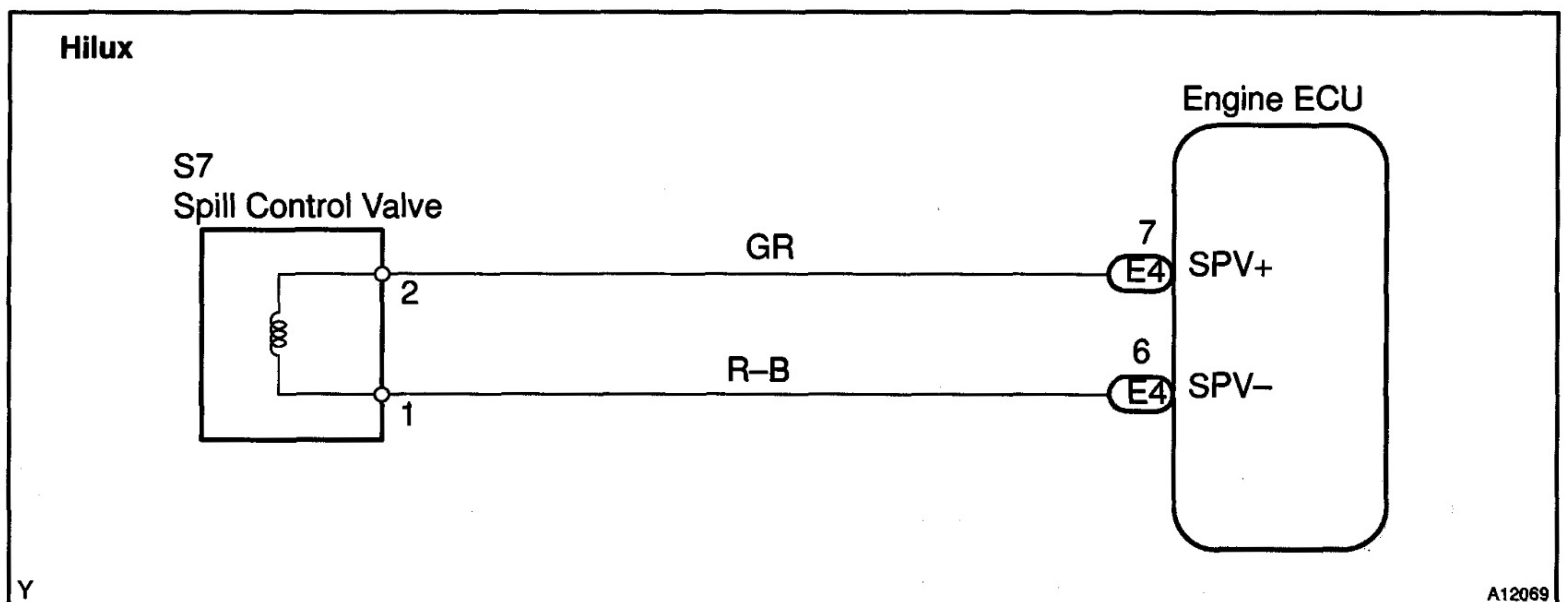

Y

A12069

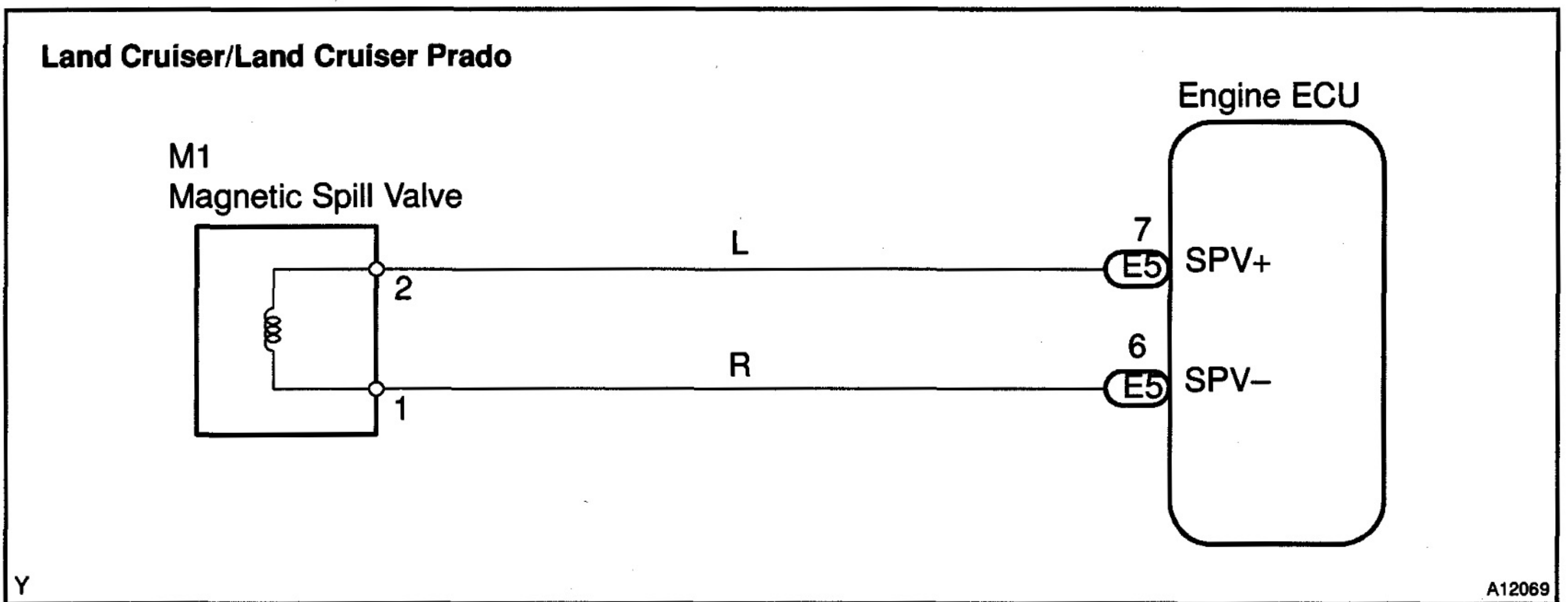
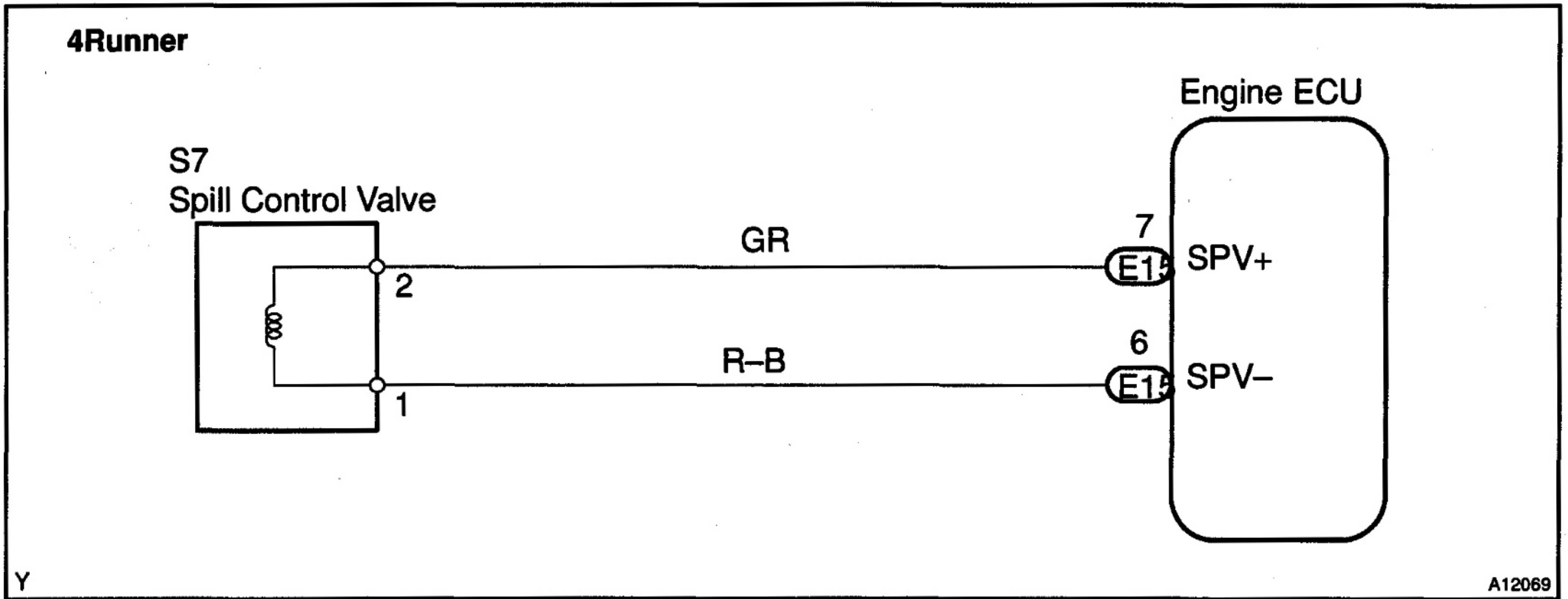

INSPECTION PROCEDURE

HINT:

Read freeze frame data using hand-held tester, as freeze frame data records the engine conditions when a malfunction is detected. When troubleshooting, it is useful for determining whether the vehicle was running or stopped, the engine was warmed up or not, the air-fuel ratio was lean or rich, etc. at the time of the malfunction.

1	Check spill control valve (See page ED-9).
----------	---

NG
Replace injection pump (See page FU-12).

OK

2 Check voltage between terminal SPV of engine ECU connector and body ground.

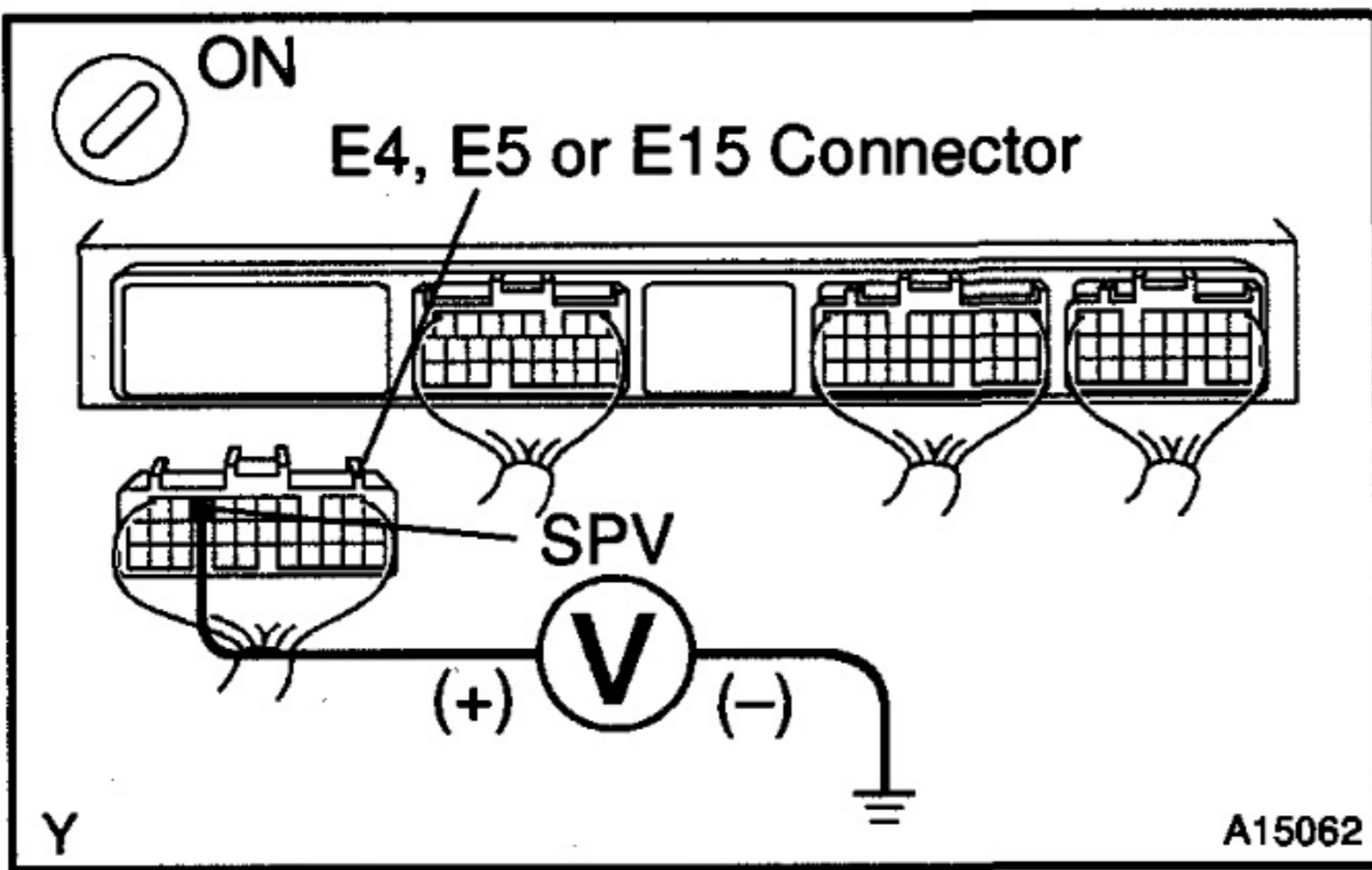

PREPARATION:

- (a) Remove the glove compartment.
- (b) Disconnect the E4 (Hilux), E5 (Land Cruiser/Land Cruiser Prado) or E15 (4Runner) connector from the engine ECU.
- (c) Turn the ignition switch ON.

CHECK:

Measure the voltage between terminal SPV of the engine ECU connector and the body ground.

OK:

Voltage: 9 - 14 V

OK → **Go to step 3.**

NG

Check for open or short in harness and connector between spill control valve and engine ECU (See page IN-20).

3 Check voltage between terminal SPV of engine ECU connector and body ground.

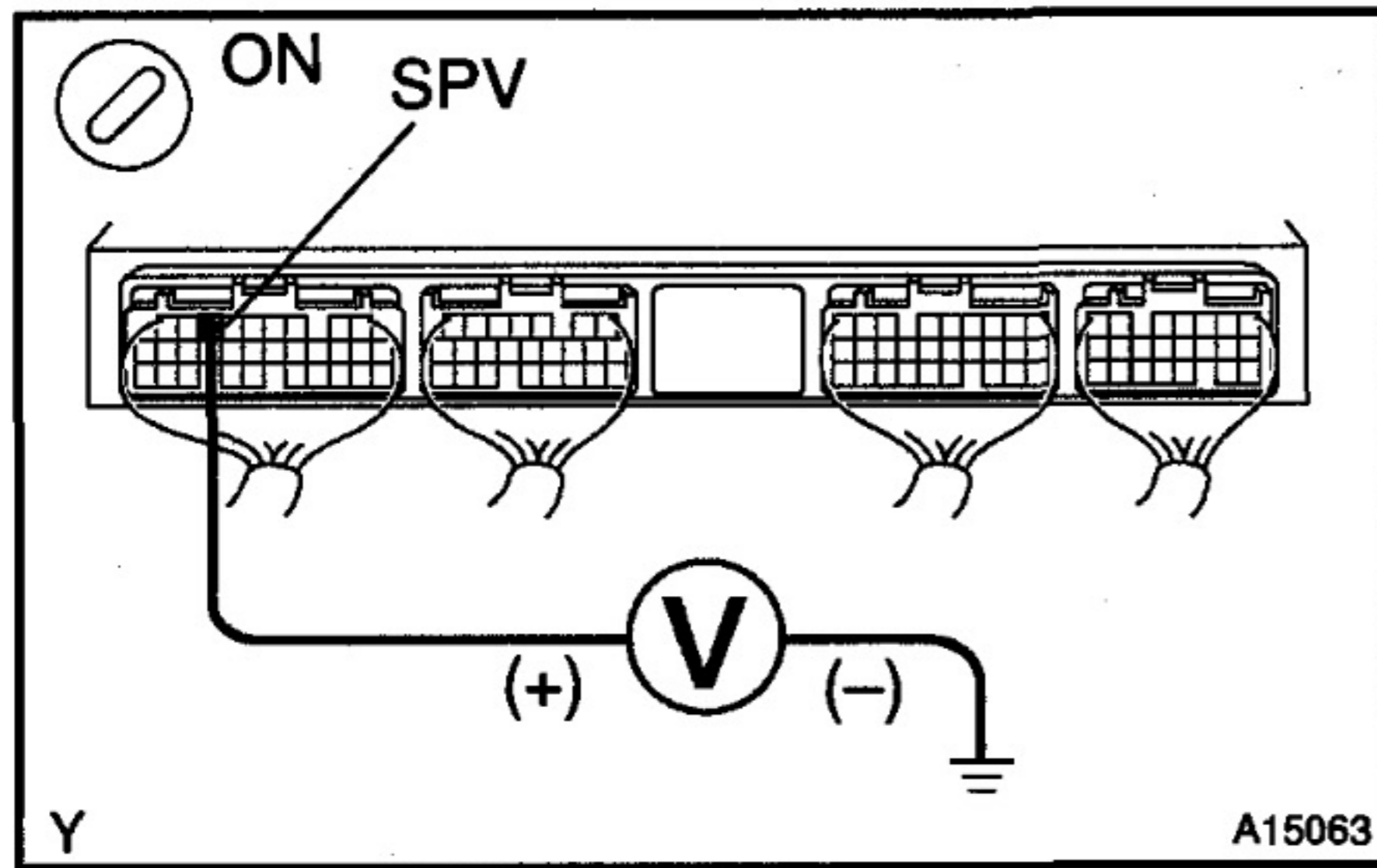

PREPARATION:

- (a) Remove the glove compartment.
- (b) Turn the ignition switch ON.

CHECK:

Measure the voltage between terminals SPV of the engine ECU connector and the body ground.

OK:

Voltage: 9 - 14 V

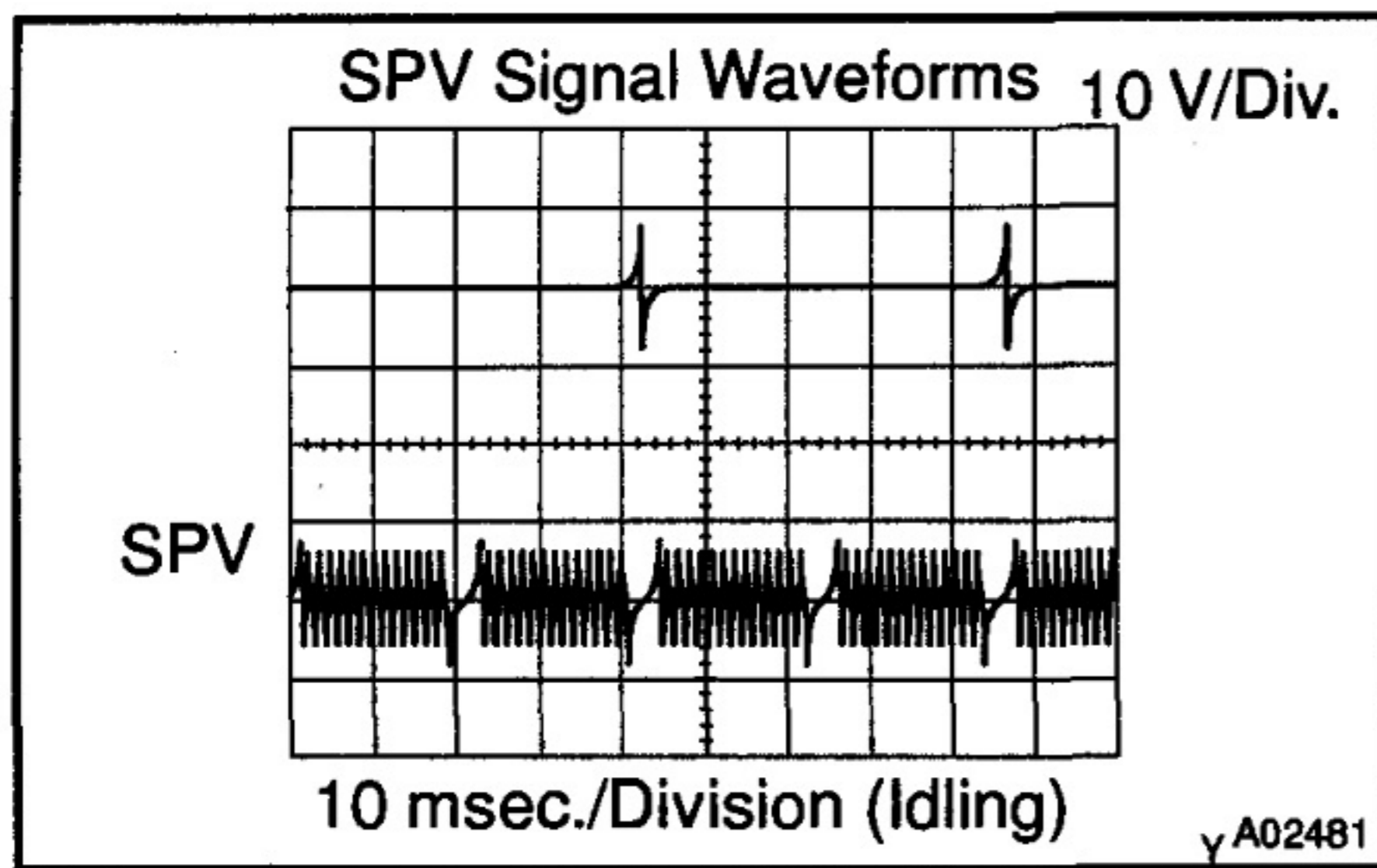

Reference: INSPECTION USING OSCILLOSCOPE

During idling, check the waveforms between terminals SPV and E1 of the engine ECU connector.

HINT:

The correct waveforms are as shown.

NG

Check and replace engine ECU (See page IN-20).

DTC	19 (1)	Accelerator Pedal Position Sensor circuit Malfunction (Open/Short)
------------	---------------	---

CIRCUIT DESCRIPTION

The accelerator pedal position sensor is mounted in the accelerator pedal and detects the accelerator pedal opening angle. When the accelerator pedal is fully closed, a voltage of approximately 1.0 V is applied to terminals VA, VAS of the engine ECU. The voltage applied to the terminals VA, VAS of the engine ECU increases in proportion to the opening angle of the accelerator pedal and becomes approximately 3.8 V when the accelerator pedal is fully opened. The engine ECU judges the vehicle driving conditions from these signals input from terminals VA, VAS and uses them as one of the conditions to control the injection volume and diesel throttle valve position. The idle switch is mounted in the accelerator pedal position sensor and sends the IDL signal to the engine ECU when the accelerator pedal is fully closed.

This system has the 2 ways accelerator pedal position sensor and accelerator pedal closed position switch for the fail safe.

DTC No.	DTC Detection Condition	Trouble Area
19 (1)	Open or short in accelerator pedal position sensor circuit for 0.05 sec. or more	<ul style="list-style-type: none"> • Open or short in accelerator pedal position sensor circuit • Accelerator pedal position sensor • Engine ECU

HINT:

After confirming DTC 19 (1), use the hand-held tester to confirm the accelerator pedal opening percentage and accelerator pedal close position switch condition.

Accelerator pedal opening position expressed as percentage		Trouble Area
Accelerator pedal fully closed	Accelerator pedal fully open	
0 %	0 %	VCC circuit open VA, VAS circuit open or short
Approx. 100 %	Approx. 100 %	E2C circuit open

WIRING DIAGRAM

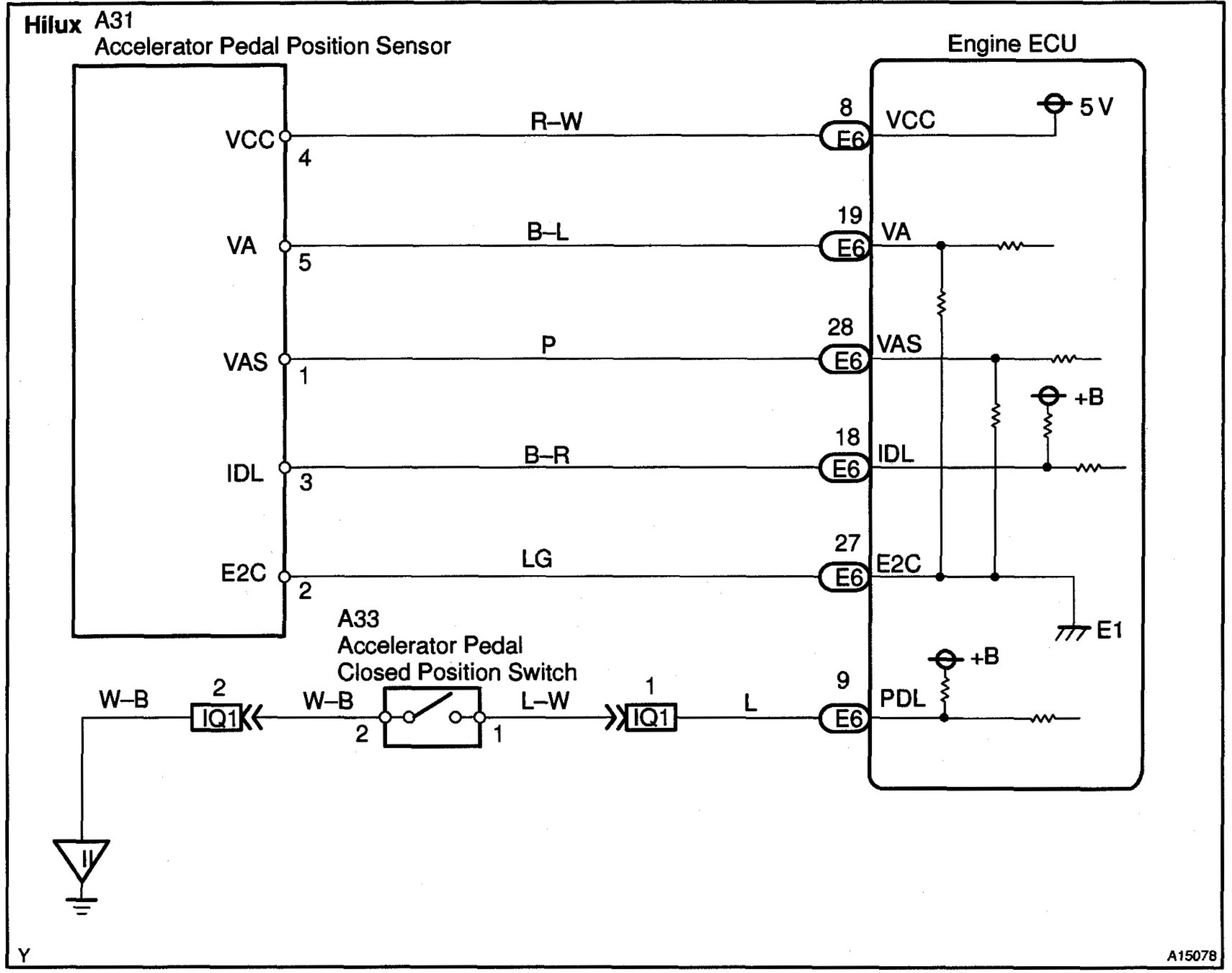

Y

A15078

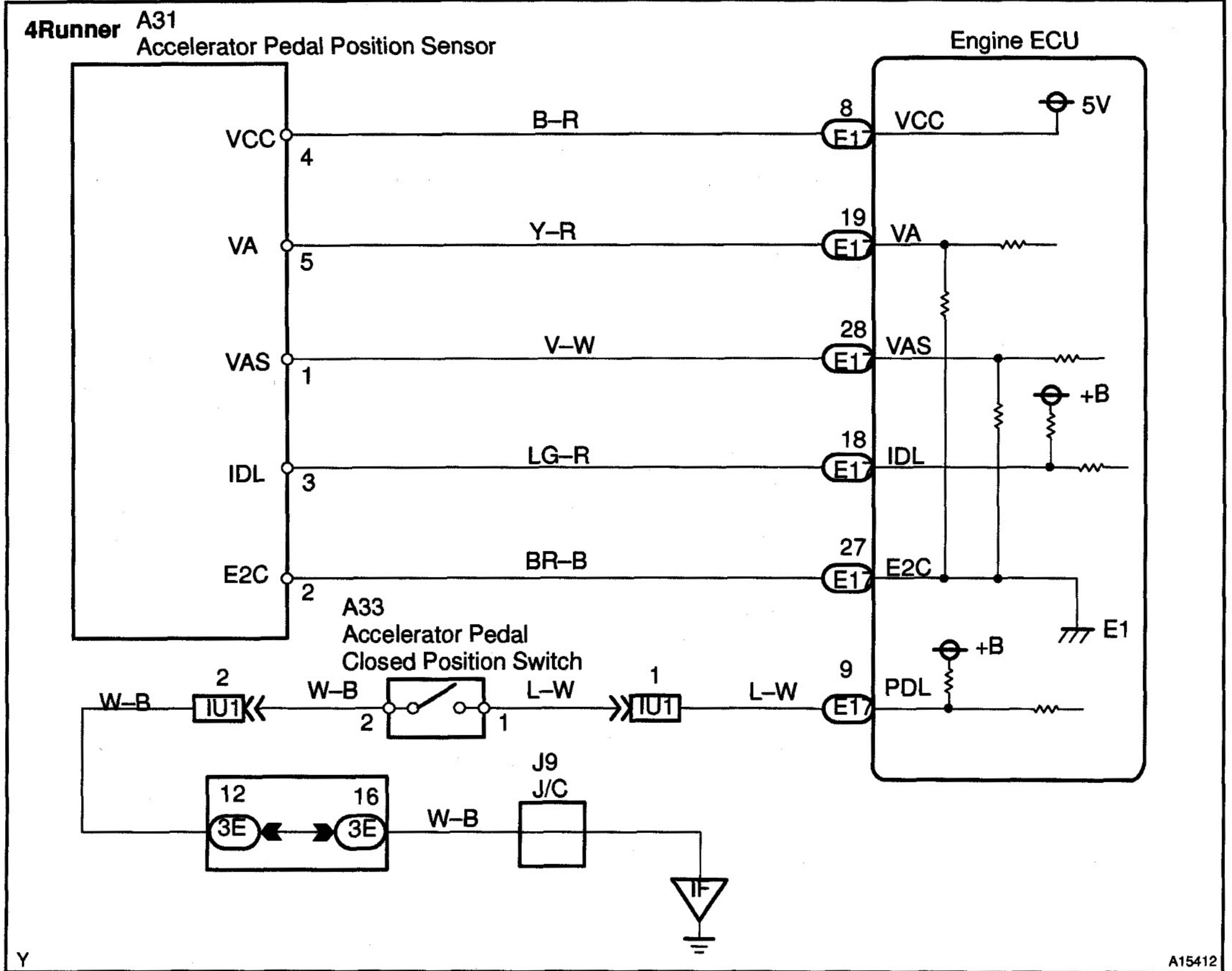

Y

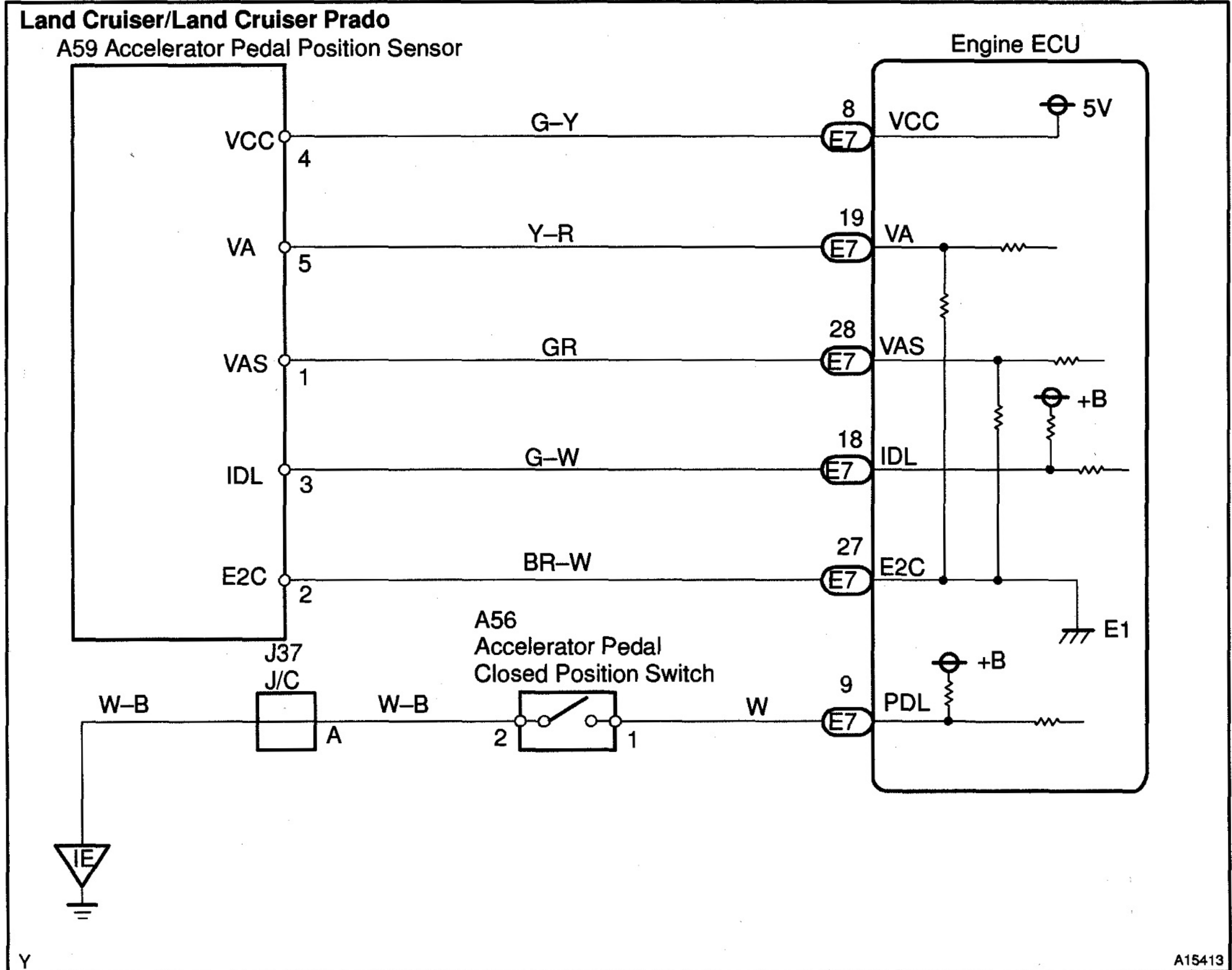

INSPECTION PROCEDURE

When using hand-held tester:

HINT:

Read freeze frame data using hand-held tester, as freeze frame data records the engine conditions when a malfunction is detected. When troubleshooting, it is useful for determining whether the vehicle was running or stopped, the engine was warmed up or not, the air-fuel ratio was lean or rich, etc. at the time of the malfunction.

1	Connect hand-held tester, read accelerator pedal opening percentage.
---	---

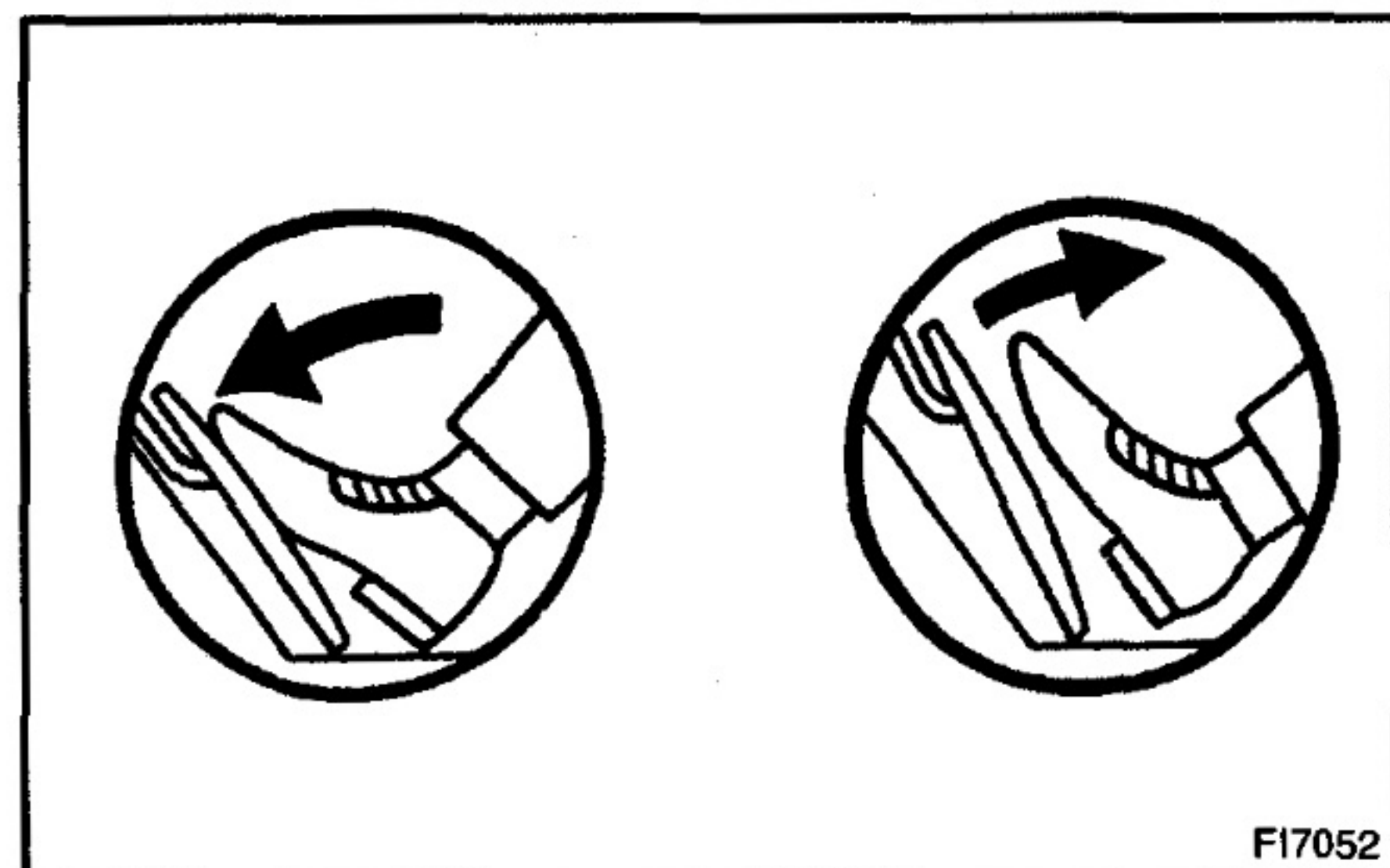

PREPARATION:

- Connect the hand-held tester to the DLC3.
- Turn the ignition switch ON and push the hand-held tester main switch ON.

CHECK:

Read the accelerator pedal opening percentage.

OK:

Accelerator pedal	Accelerator pedal opening position expressed as percentage
Fully released	Approx. 65 %
Fully depressed	Approx. 18 %

OK → Check for intermittent problems (See page DI-4).

NG

2 Check voltage between terminal 4 of wire harness side connector and body ground.

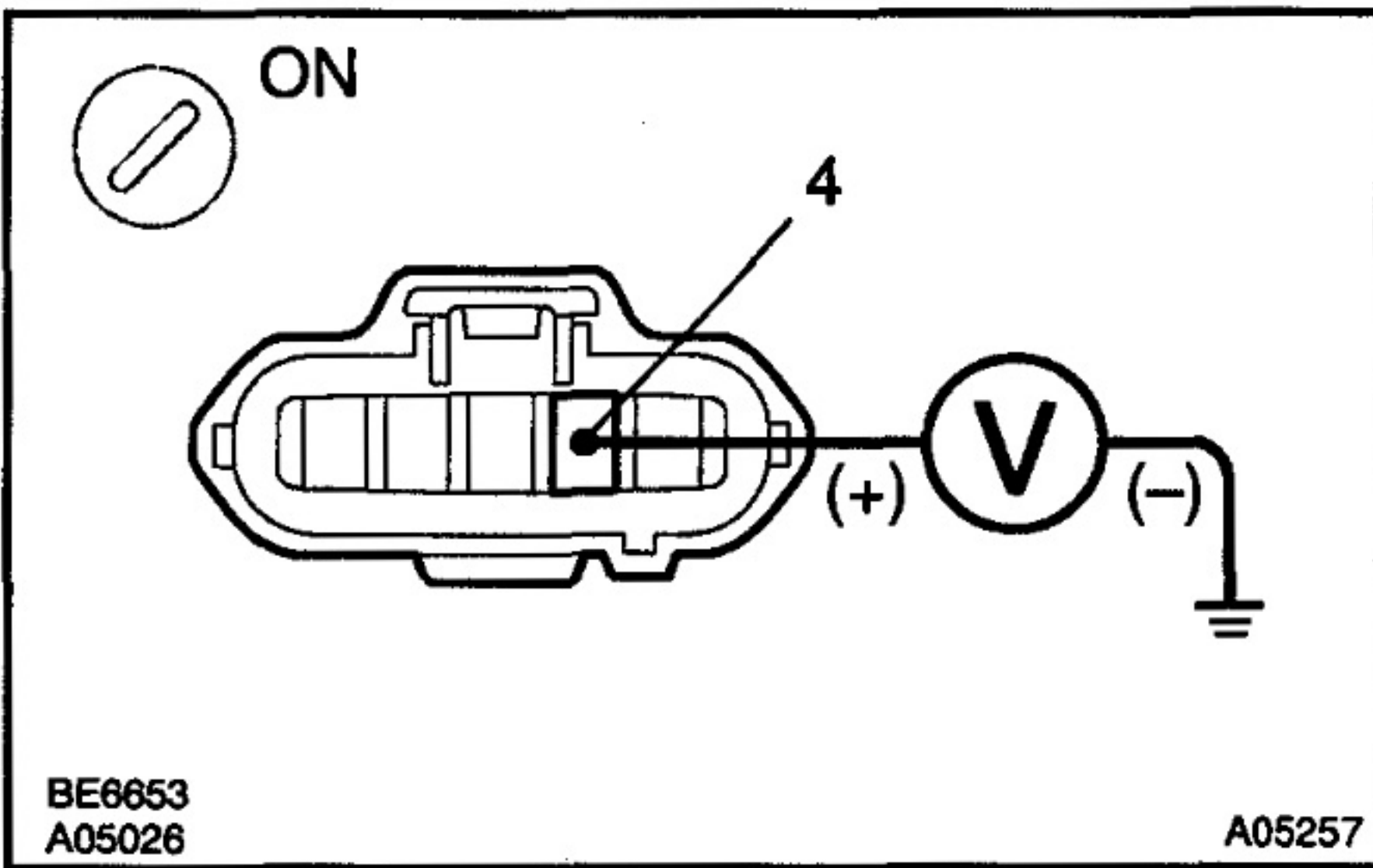

PREPARATION:

- (a) Disconnect the accelerator pedal position sensor connector.
- (b) Turn the ignition switch ON.

CHECK:

Measure the voltage between terminal 4 of the wire harness side connector and the body ground.

OK:

Voltage: 4.5 – 5.5 V

NG → Go to step 5.

OK

3 Check voltage between terminals VA/VAS and E2C of engine ECU connector.

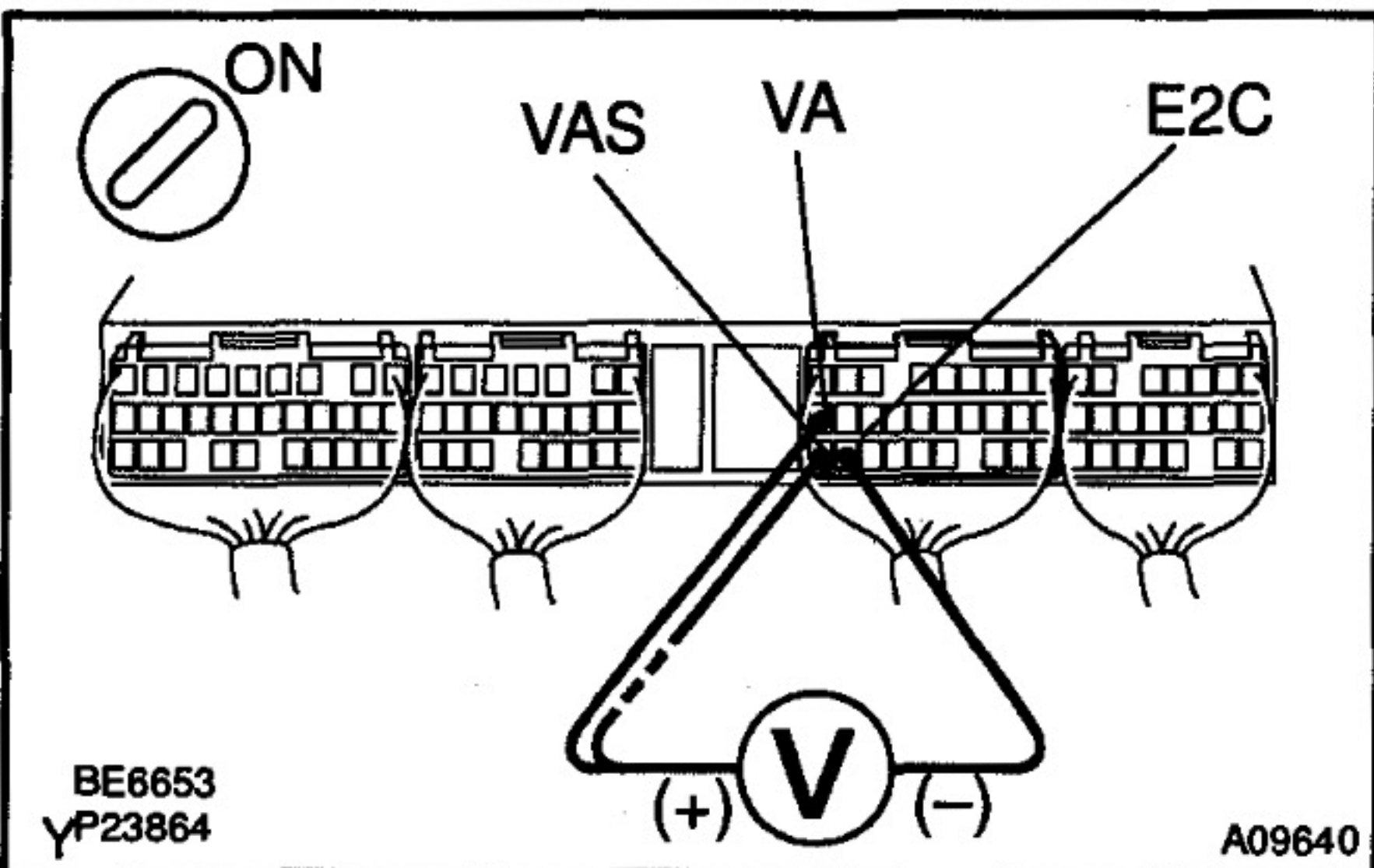

PREPARATION:

- (a) Remove the glove compartment door.
- (b) Turn the ignition switch ON.

CHECK:

Measure the voltage between terminals VA/VAS and E2C of the engine ECU connector.

OK:

Accelerator Pedal	Voltage
Fully released	0.6 – 1.3 V
Fully depressed	2.8 – 4.5 V

OK → Check and replace engine ECU (See page IN-20).

NG

- 4 Check for open and short in harness and connector in VA or VAS between engine ECU and accelerator pedal position sensor (See page IN-20).

NG

Repair or replace harness or connector.

OK

Replace accelerator pedal.

- 5 Check voltage between terminals VCC and E2C of engine ECU connector.

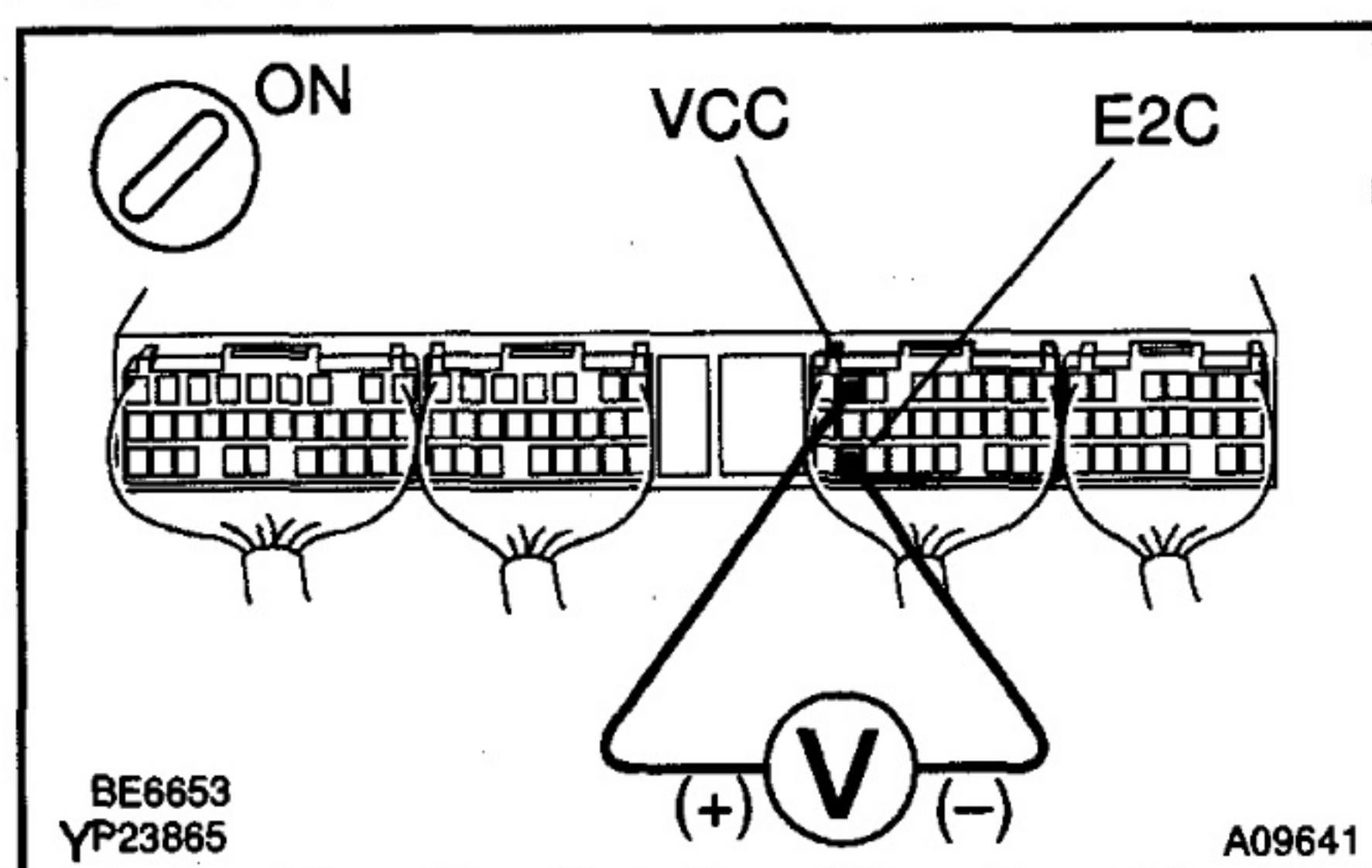
**PREPARATION:**

- (a) Remove the glove compartment door.
 (b) Turn the ignition switch ON.

CHECK:

Measure the voltage between terminals VCC and E2C of the engine ECU connector.

OK:

Voltage: 4.5 – 5.5 V

NG

Check and replace engine ECU (See page IN-20).

OK

Check for open in harness and connector in VCC circuit between engine ECU and accelerator pedal position sensor (See page IN-20).

When not using hand-held tester:

- 1 Check voltage between terminal 4 of wire harness side connector and body ground.**

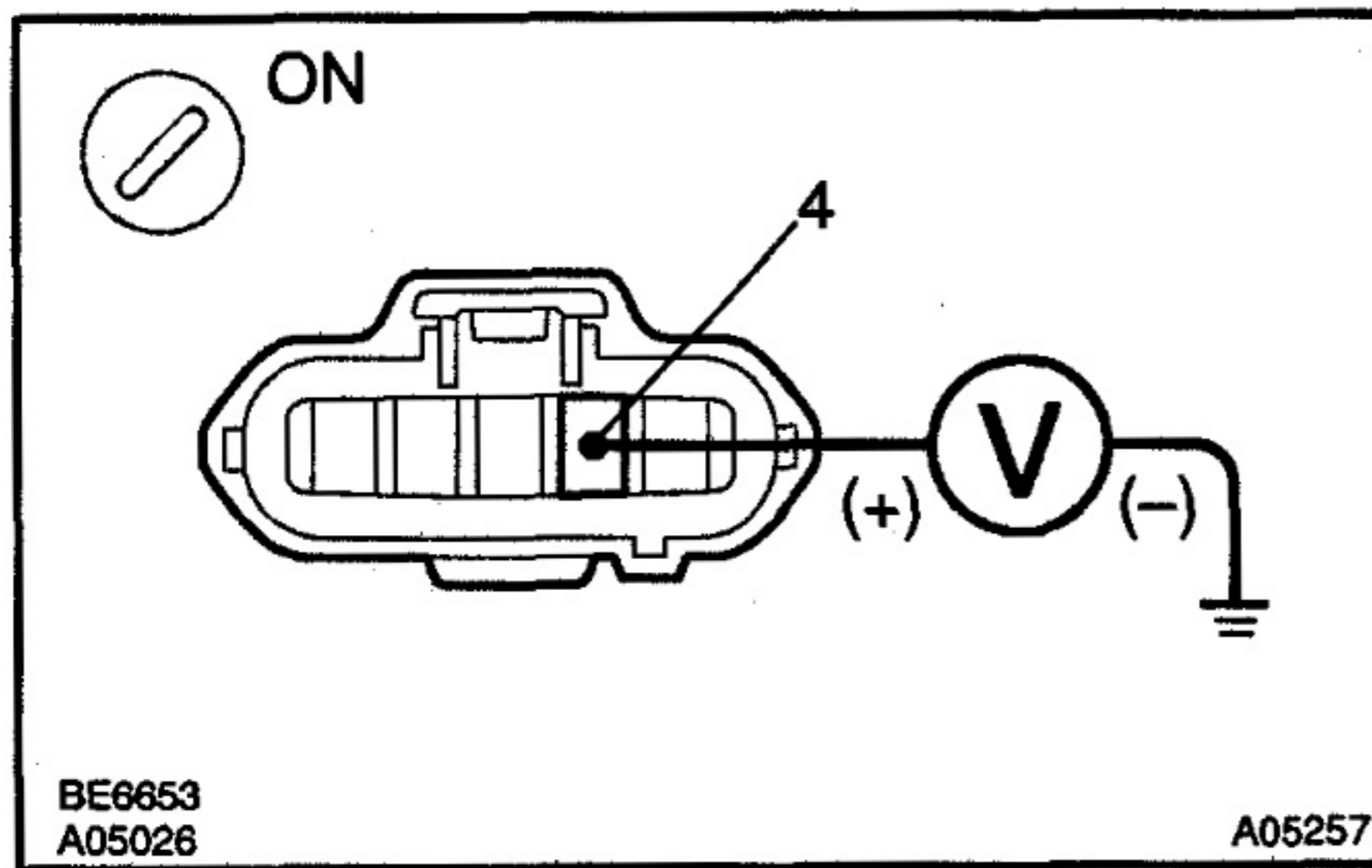
**PREPARATION:**

- (a) Disconnect the accelerator pedal position sensor connector.
 (b) Turn the ignition switch ON.

CHECK:

Measure the voltage between terminal 4 of the wire harness side connector and the body ground.

OK:

Voltage: 4.5 – 5.5 V

NG

Go to step 4.

OK

- 2 Check voltage between terminals VA/VAS and E2C of engine ECU connector.**

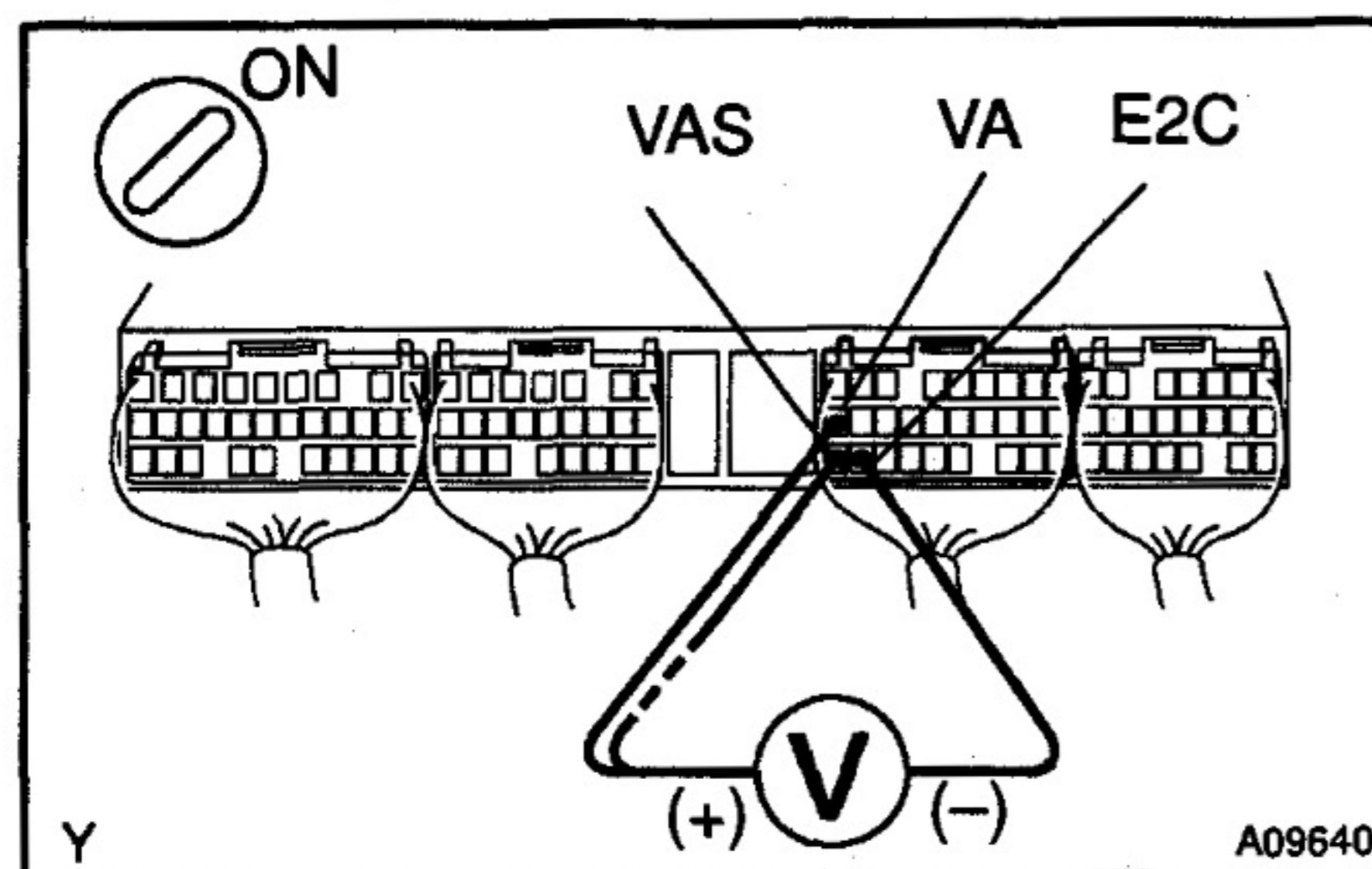
**PREPARATION:**

- (a) Remove the glove compartment door.
 (b) Turn the ignition switch ON.

CHECK:

Measure the voltage between terminals VA/VAS and E2C of the engine ECU connector.

OK:

Accelerator pedal	Voltage
Fully released	0.6 – 1.3 V
Fully depressed	2.8 – 4.5 V

OK

Check and replace engine ECU (See page IN-20).

NG

- 3 Check for open and short in harness and connector in VA or VAS circuit between engine ECU and accelerator pedal position sensor (See page IN-20).**

NG

Repair or replace harness or connector.

OK

Replace accelerator pedal.

4 Check voltage between terminals VCC and E2C of engine ECU connector.

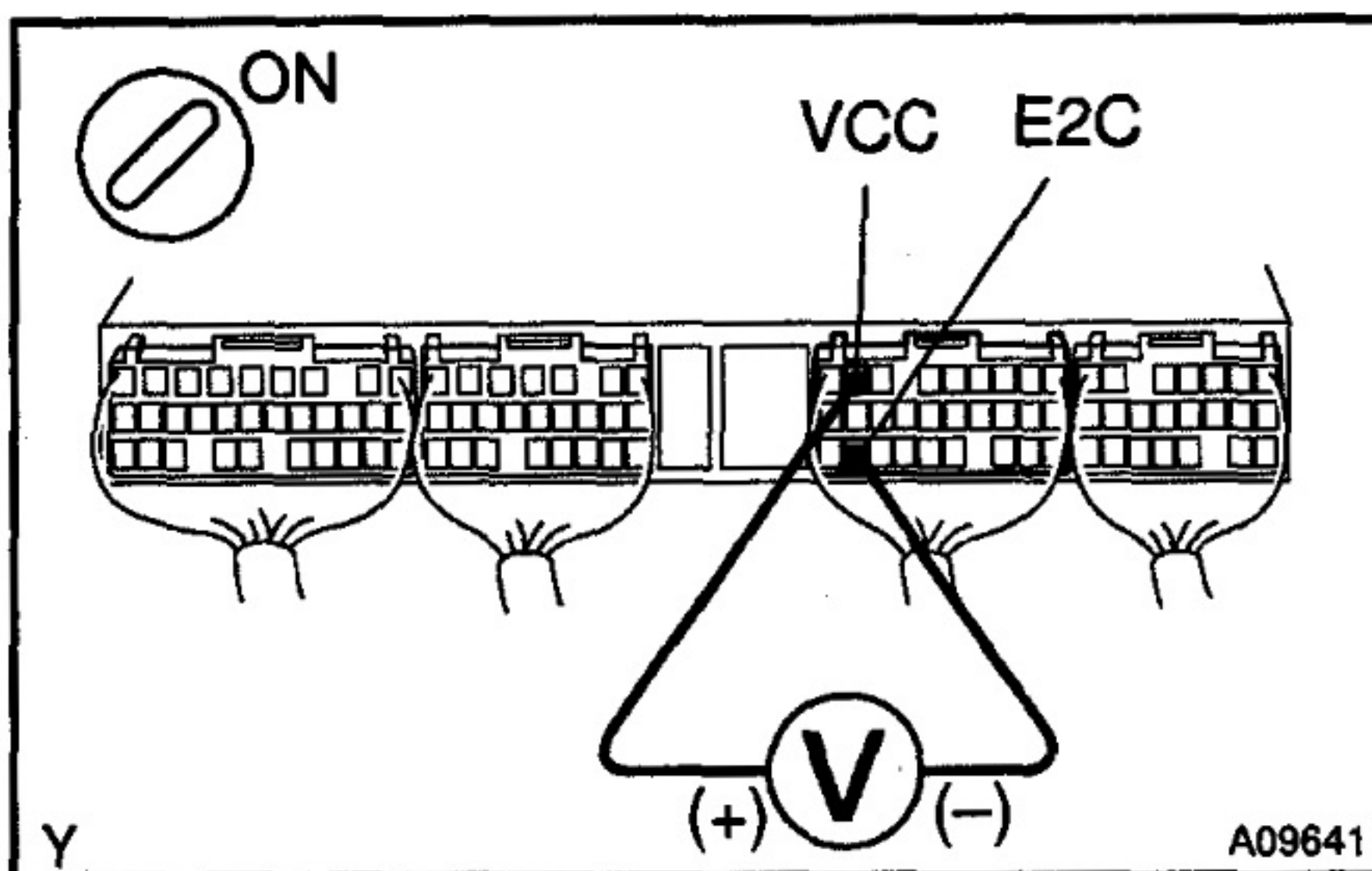
**PREPARATION:**

- (a) Remove the glove compartment door.
- (b) Turn the ignition switch ON.

CHECK:

Measure the voltage between terminals VCC and E2C of the engine ECU connector.

OK:

Voltage: 4.5 – 5.5 V

NG

Check and replace engine ECU (See page IN-20).

OK

Check for open in harness and connector in VCC circuit between engine ECU and accelerator pedal position sensor (See page IN-20).

DTC	19 (2)	Accelerator Pedal Position Sensor Circuit Malfunction (IDL Switch/Range)
------------	---------------	---

CIRCUIT DESCRIPTION

Refer to DTC 19 (1) on page DI-42.

DTC No.	DTC Detection Condition	Trouble Area
19 (2)	Condition (a) or (b) continues for 0.5 seconds or more: (a) IDL ON and VA > 1.4 V (b) IDL ON and VAS > 1.4 V	<ul style="list-style-type: none"> • Open or short in accelerator pedal position sensor circuit • Accelerator pedal position sensor • Engine ECU
	Condition (a) or (b) continues for 0.5 seconds or more: (a) IDL OFF and VA < 0.6 V (b) IDL OFF and VAS < 0.6 V	
	Conditions (a) and (b) continue 0.05 seconds or more: (a) 0.6 V < VA < 4.4 V and 0.6 V < VAS < 4.4 V (b) VA - VAS > 0.5 V	

WIRING DIAGRAM

Refer to DTC 19 (1) on page DI-42.

INSPECTION PROCEDURE

When using hand-held tester:

HINT:

Read freeze frame data using hand-held tester, as freeze frame data records the engine conditions when a malfunction is detected. When troubleshooting, it is useful for determining whether the vehicle was running or stopped, the engine was warmed up or not, the air-fuel ratio was lean or rich, etc. at the time of the malfunction.

1	Connect hand-held tester to DLC3, read IDL signal.
----------	---

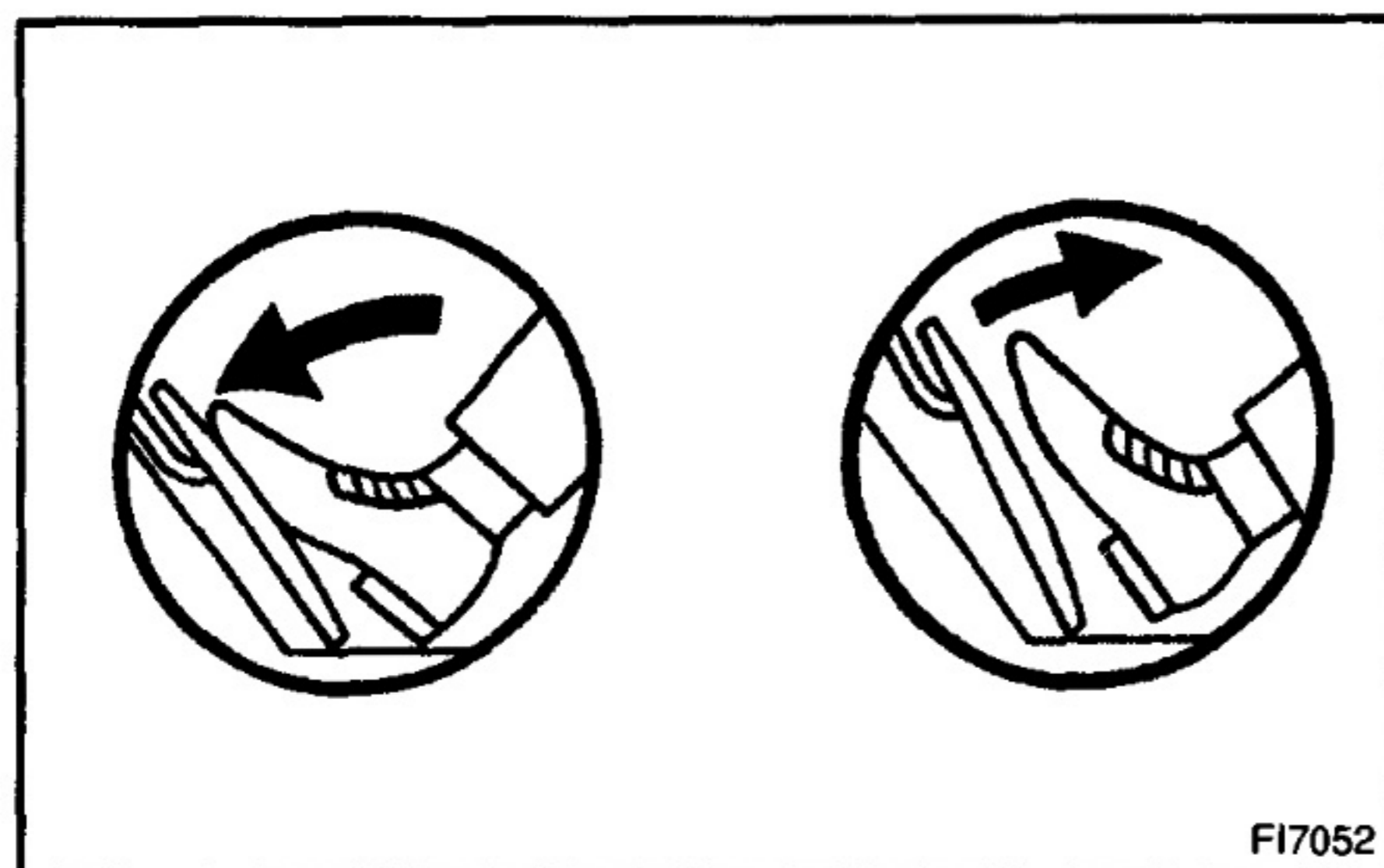

PREPARATION:

- Connect the hand-held tester to the DLC3.
- Turn the ignition switch ON and push the hand-held tester main switch ON.

CHECK:

Read the IDL signal.

OK:

Accelerator Pedal	IDL Signal
Fully released	OFF
Fully depressed	ON

OK	Go to step 4.
-----------	----------------------

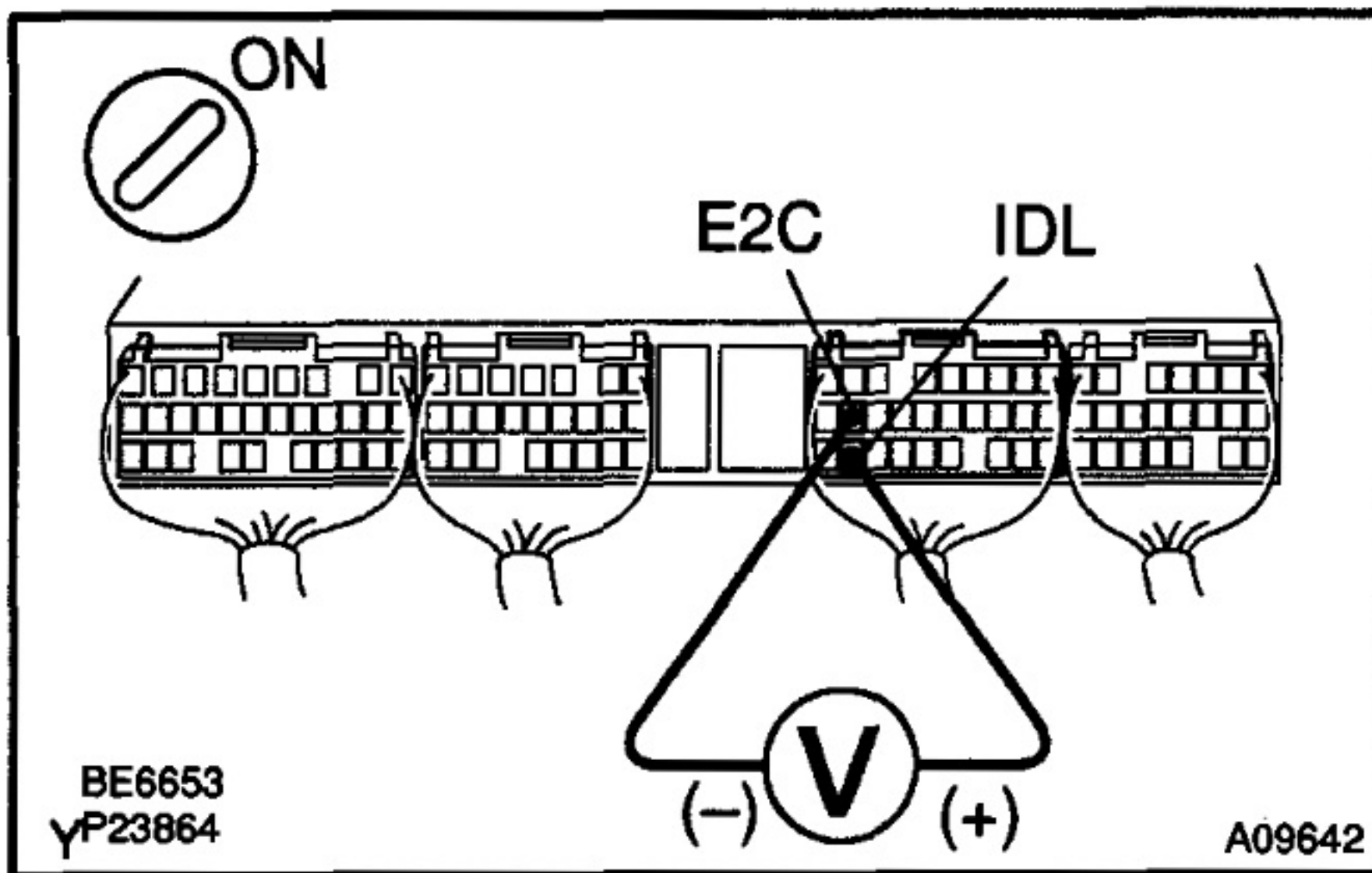

2 Check voltage between terminals IDL and E2C of engine ECU connector.

**PREPARATION:**

- (a) Remove the glove compartment door.
- (b) Turn the ignition switch ON.

CHECK:

Measure the voltage between terminals IDL and E2C of the engine ECU connector.

OK:

Accelerator Pedal	Voltage
Fully released	9 - 14 V
Fully depressed	0 - 3 V

OK

Check and replace engine ECU (See page IN-20).

NG

3 Check for open and short in harness and connector in IDL circuit between engine ECU and accelerator pedal position sensor (See page IN-20).

NG

Repair or replace harness or connector.

OK

Replace accelerator pedal.

4 Connect hand-held tester, read accelerator pedal operating percentage (See page DI-42, step 1).

OK

Check for intermittent problems (See page DI-4).

OK

5 Check voltage between terminal VCC of wire harness side connector and body ground (See page DI-42, step 2).

NG

Go to step 8.

OK

6 Check voltage between terminals VA, VAS and E2C of engine ECU connector (See page DI-42, step 3).

OK

Check and replace engine ECU (See page IN-20).

NG

7 Check for open and short in harness and connector in VA or VAS circuit between engine ECU and accelerator pedal position sensor (See page IN-20).

NG

Repair or replace harness or connector.

OK

Replace accelerator pedal.

8 Check voltage between terminals VCC and E2C of engine ECU connector (See page DI-42, step 5).

NG

Check and replace engine ECU (See page IN-20).

OK

Check for open in harness and connector in VCC circuit between engine ECU and accelerator pedal position sensor (See page IN-20).

When not using hand-held tester:

1 Check voltage between terminals IDL and E2C of engine ECU connector.

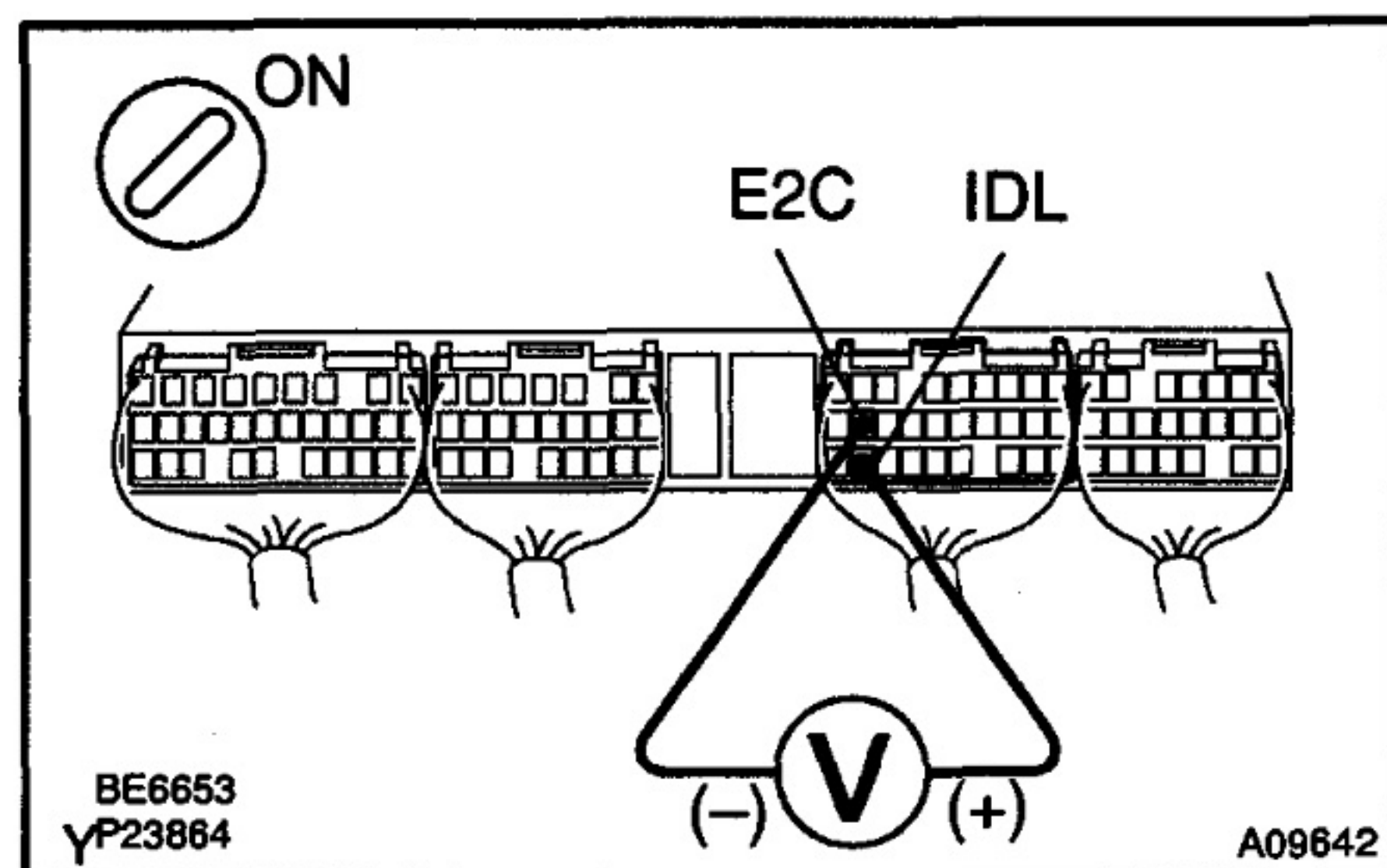
**PREPARATION:**

- (a) Remove the glove compartment door.
 (b) Turn the ignition switch ON.

CHECK:

Measure the voltage between terminals IDL and E2C of the engine ECU connector.

OK:

Accelerator Pedal	Voltage
Fully released	9 - 14 V
Fully depressed	0 - 3 V

OK

Go to step 3.

NG

2 Check for open and short in harness and connector in IDL circuit between engine ECU and accelerator pedal position sensor (See page IN-20).

NG

Repair or replace harness or connector.

OK

Replace accelerator pedal.

3 Check voltage between terminal 4 of wire harness side connector and body-ground (See page DI-42, step 2).

NG

Go to step 6.

OK

4 Check voltage between terminals VA, VAS and E2C of engine ECU connector (See page DI-42, step 3).

OK

Check and replace engine ECU (See page IN-20).

NG

5 Check for open and short in harness and connector in VA or VAS circuit between engine ECU and accelerator pedal position sensor (See page IN-20).

NG

Repair or replace harness or connector.

OK

Replace accelerator pedal.

6 Check voltage between terminals VCC and E2C of engine ECU connector (See page DI-42, step 5).

NG

Check and replace engine ECU (See page IN-20).

OK

Check for open in harness and connector in VCC line between engine ECU and accelerator pedal position sensor (See page IN-20).

DTC	19 (3)	Accelerator Pedal Closed Position Switch Circuit Malfunction (Short)
------------	---------------	---

DTC	19 (4)	Accelerator Pedal Closed Position Switch Circuit Malfunction (Open)
------------	---------------	--

CIRCUIT DESCRIPTION

Refer to DTC 19 (1) on page DI-42.

DTC No.	DTC Detection Condition	Trouble Area
19(3)	Conditions (a), (b) and (c) continue 0.5 sec. or more: (c) PDL ON (d) VA > Fully closed study voltage +0.41 V (e) VAS > Fully closed study voltage +0.41 V	<ul style="list-style-type: none"> • Short in accelerator pedal closed position switch circuit • Accelerator pedal closed position switch • Engine ECU
19(4)	PDL does not turn ON even once while driving vehicle (2 trip detection logic) Conditions (a) and (b) continue 5 sec. or more: (a) PDL OFF (b) IDL ON	<ul style="list-style-type: none"> • Open in accelerator pedal closed position switch circuit • Accelerator pedal closed position switch • Engine ECU

WIRING DIAGRAM

Refer to DTC 19 (1) on page DI-42.

INSPECTION PROCEDURE

HINT:

Read freeze frame data using hand-held tester, as freeze frame data records the engine conditions when a malfunction is detected. When troubleshooting, it is useful for determining whether the vehicle was running or stopped, the engine was warmed up or not, the air-fuel ratio was lean or rich, etc. at the time of the malfunction.

1	Check accelerator pedal closed position switch (See page ED-20).
----------	---

PREPARATION:

Disconnect the accelerator pedal closed position switch connector.

CHECK:

Measure the resistance between terminals of accelerator pedal closed position switch.

OK:

Terminals	Accelerator Pedal	Resistance
1 - 2	Fully released	∞
1 - 2	Fully depressed	0 - 20 Ω

NG

Replace accelerator pedal (See page ED-20).

OK

2 Check voltage between terminal PDL of engine ECU connector and body ground.

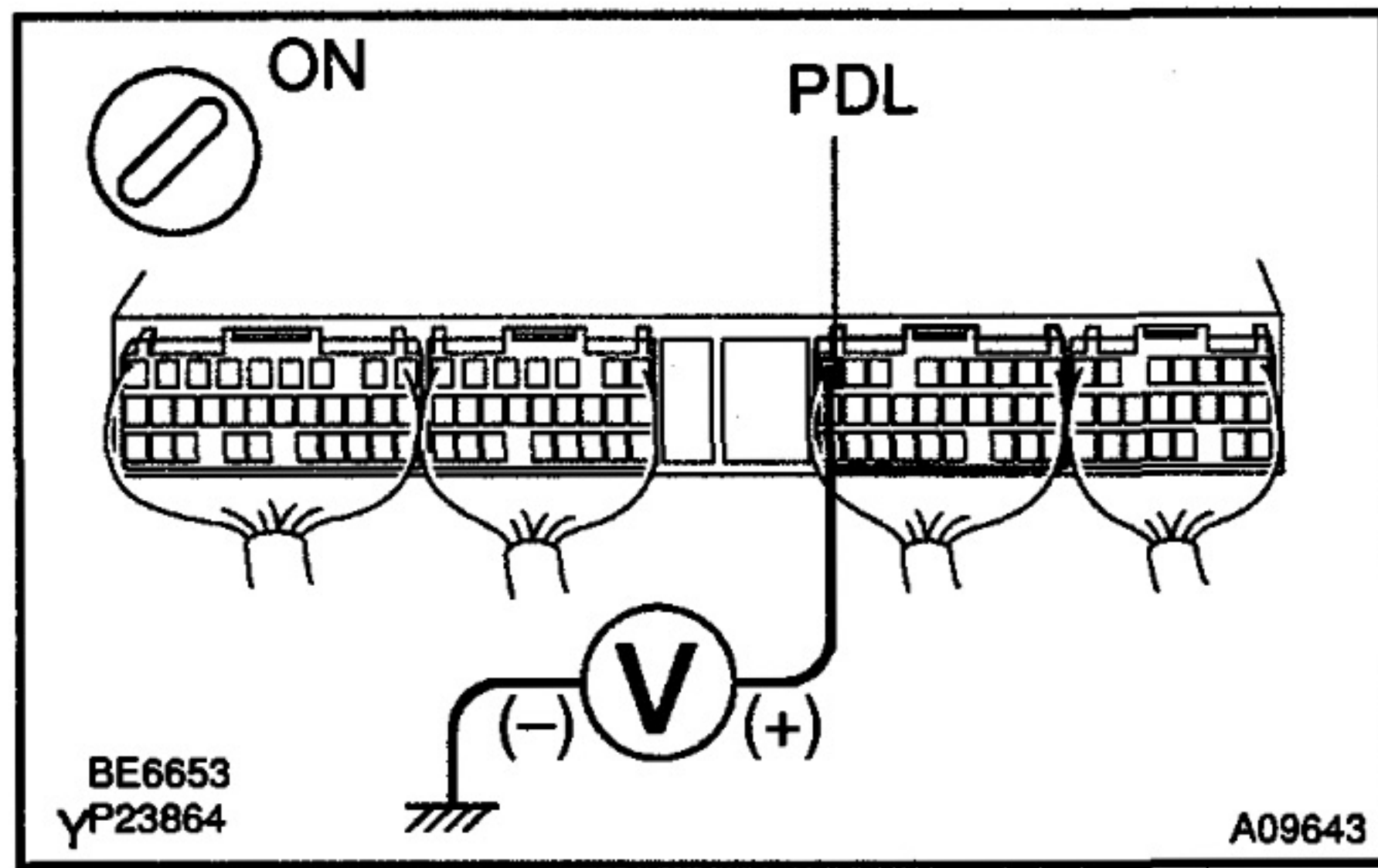

PREPARATION:

- (a) Remove the glove compartment door.
- (b) Turn the ignition switch ON.

CHECK:

Measure the voltage between terminal PDL of the engine ECU connector and the body ground.

OK:

Accelerator Pedal	Voltage
Fully released	9 - 14 V
Fully depressed	0 - 3 V

OK → Check and replace engine ECU (See page IN-20).

NG

Check for open and short in harness and connector between engine ECU and accelerator pedal closed position switch, and accelerator pedal closed position switch and body ground (See page IN-20).

DTC	22	Water Temp. Sensor Circuit Malfunction
------------	-----------	---

CIRCUIT DESCRIPTION

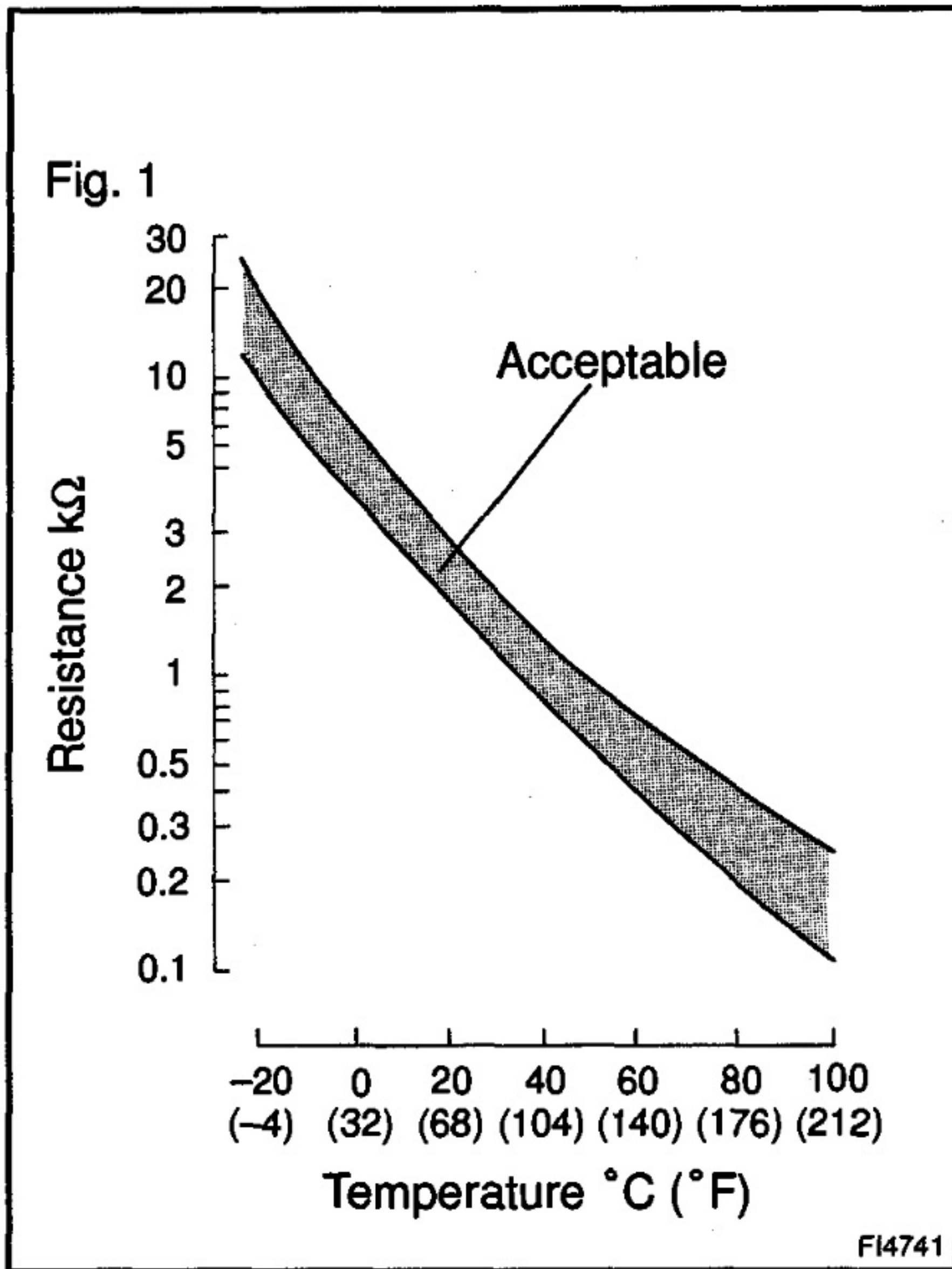

The water temperature sensor senses the coolant temperature. A thermistor built in the sensor changes the resistance value according to the coolant temperature. The lower the coolant temperature, the greater the thermistor resistance value, and the higher the coolant temperature, the lower the thermistor resistance value (See Fig. 1).

The water temperature sensor is connected to the engine ECU (See below). The 5 V power source voltage in the engine ECU is applied to the water temperature sensor from terminal THW via a resistor R. That is, the resistor R and the water temperature sensor are connected in series. When the resistance value of the water temperature sensor changes in accordance with changes in the coolant temperature, the potential at terminal THW also changes. Based on this signal, the engine ECU increases the fuel injection volume to improve driveability during the cold engine operation.

DTC No.	DTC Detection Condition	Trouble Area
22	Open or short in water temp. sensor circuit for 0.5 sec. or more	<ul style="list-style-type: none"> • Open or short in water temp. sensor circuit • Water temp. sensor • Engine ECU

HINT:

After confirming DTC22, use the hand-held tester to confirm the water temperature from the CURRENT DATA.

Displayed Temperature	Malfunction
-40°C (-40°F)	Open circuit
140°C (284°F) or more	Short circuit

WIRING DIAGRAM

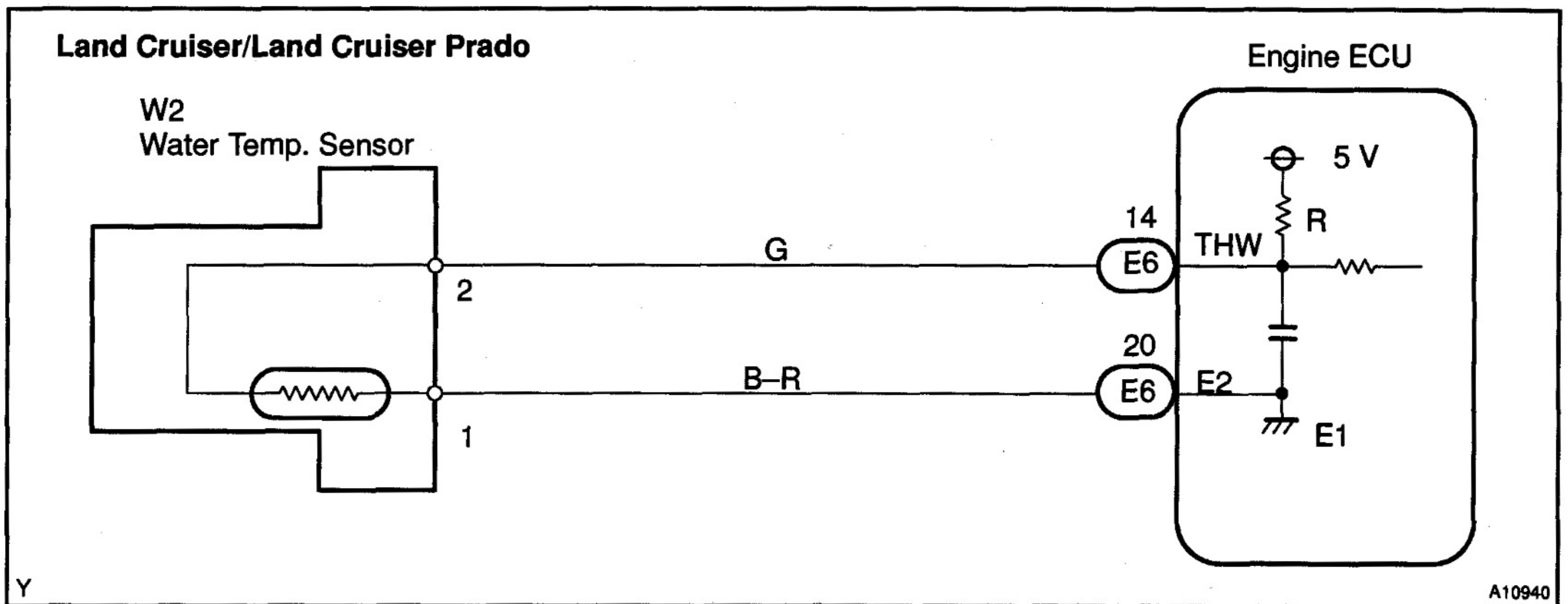
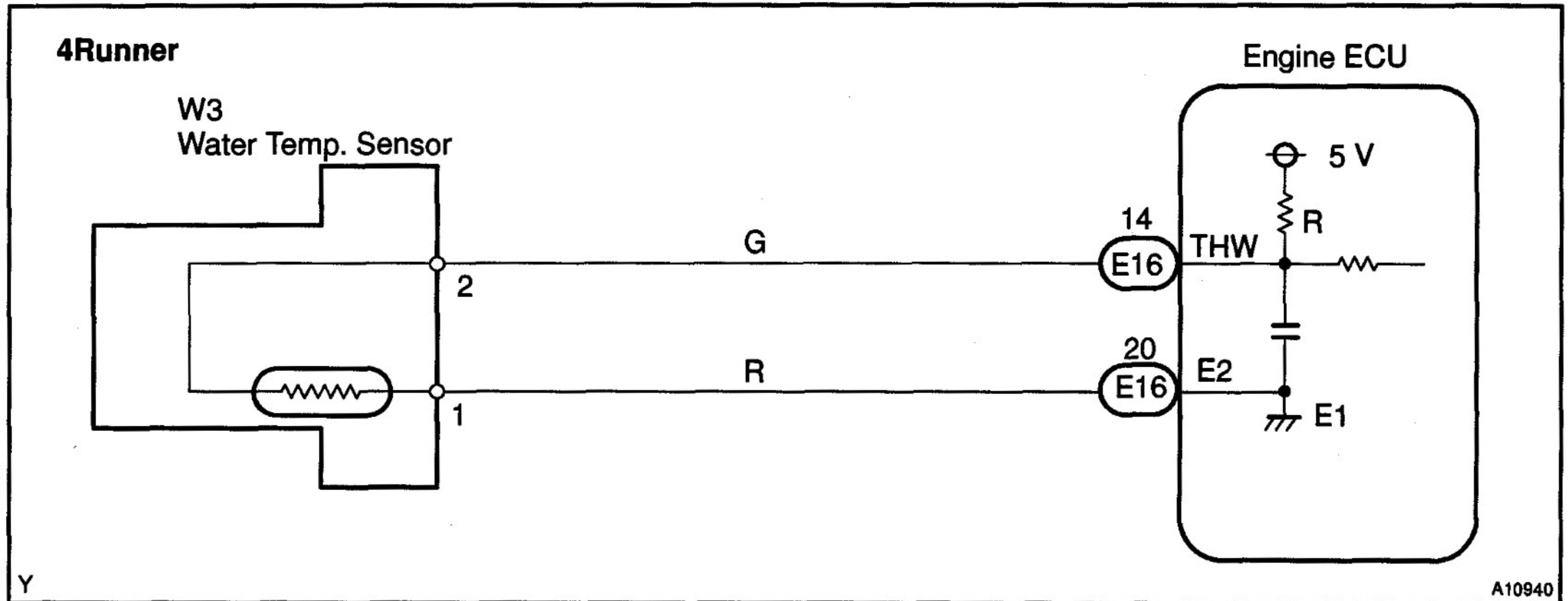
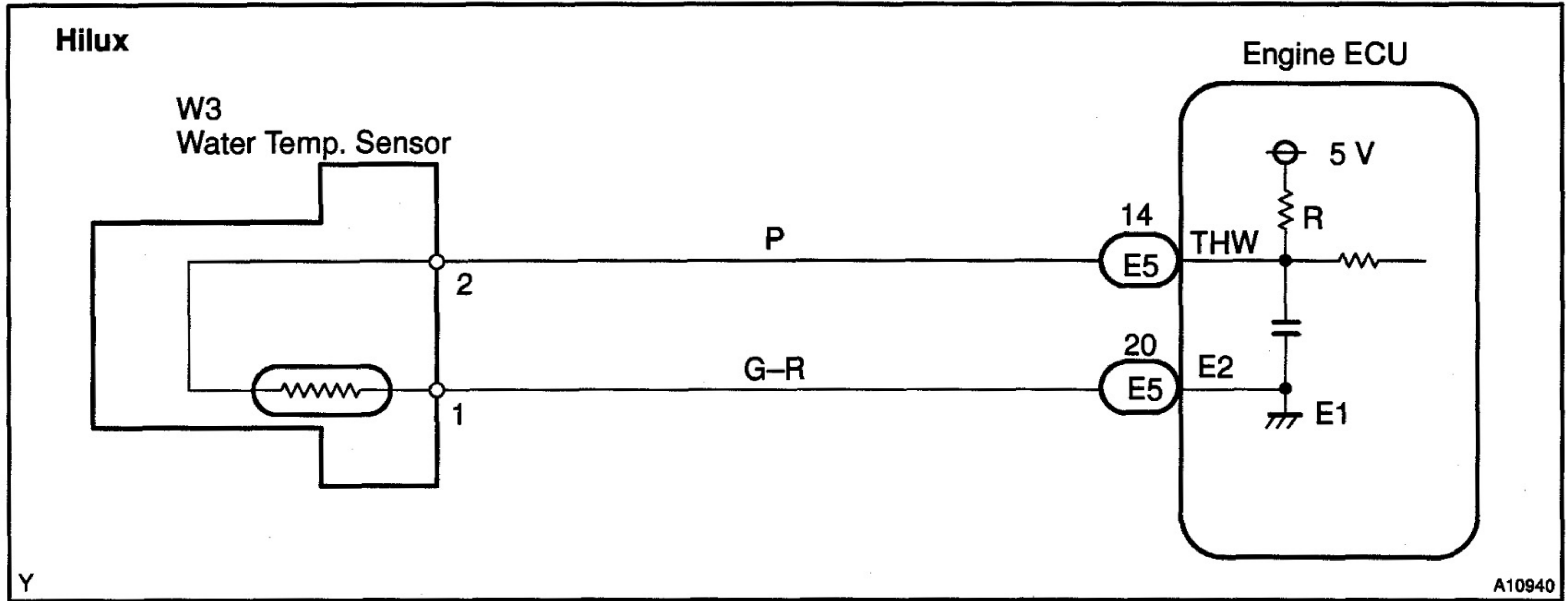

INSPECTION PROCEDURE

HINT:

- If DTC22, 24 and 39 are output simultaneously, E2 (sensor ground) may be open.
- Read freeze frame data using hand-held tester, as freeze frame data records the engine conditions when a malfunction is detected. When troubleshooting, it is useful for determining whether the vehicle was running or stopped, the engine was warmed up or not, the air-fuel ratio was lean or rich, etc. at the time of the malfunction.

When using hand-held tester:

1	Connect hand-held tester, and read value of water temperature.
----------	---

PREPARATION:

- Connect the hand-held tester to the DLC3.
- Turn the ignition switch ON and push the hand-held tester main switch ON.

CHECK:

Read the temperature value on the hand-held tester.

OK:

Same value as the actual water temperature.

HINT:

- If there is open circuit, hand-held tester indicates -40°C (-40°F).
- If there is short circuit, hand-held tester indicates 140°C (284°F) or more.

NG

-40°C (-40°F) ... Go to step 2.
 140°C (284°F) or more ... Go to step 4.

OK

Check for intermittent problems (See page DI-4).

2	Check for open in harness or engine ECU.
----------	---

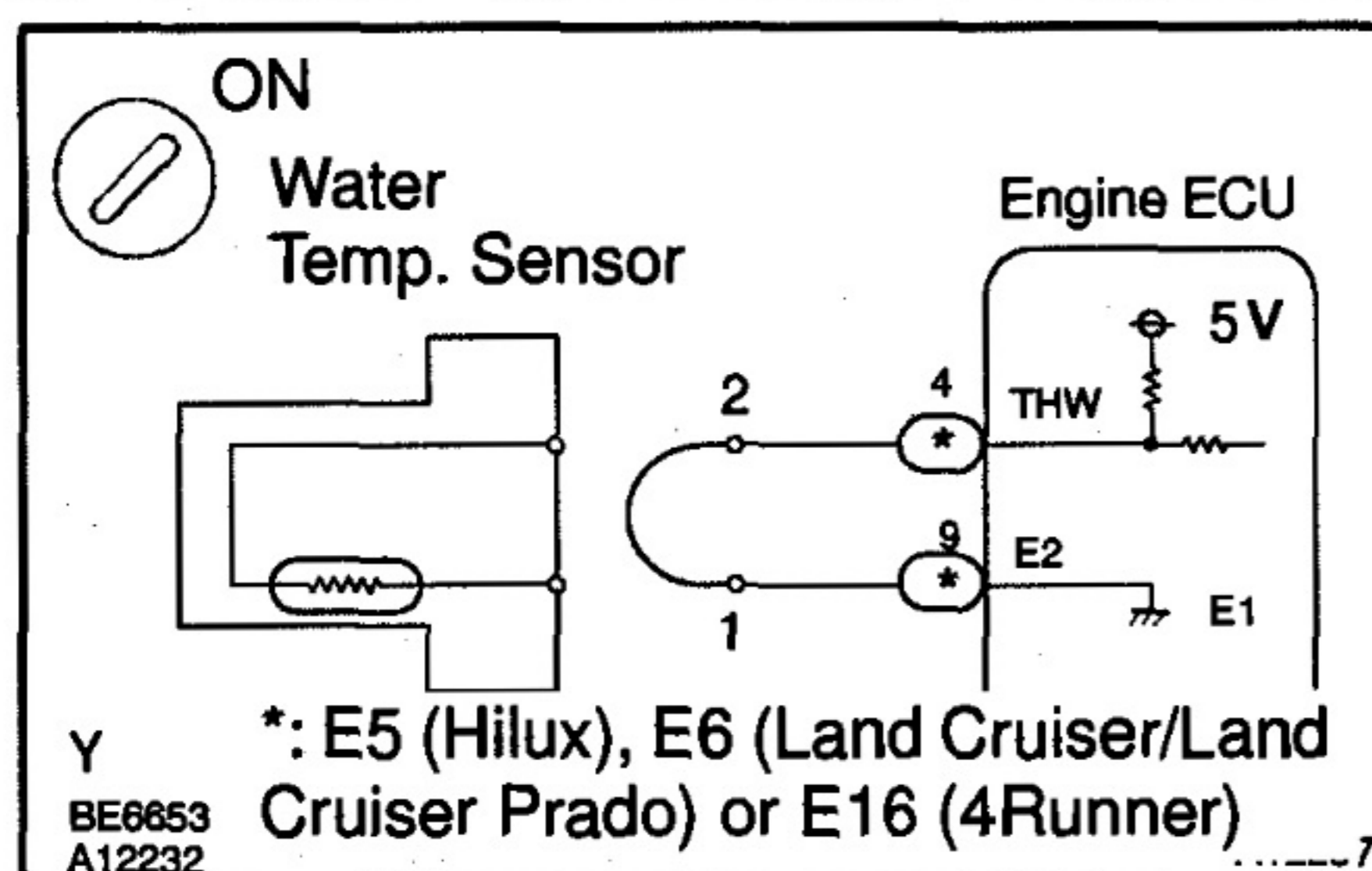

PREPARATION:

- Disconnect the water temperature sensor connector.
- Connect the sensor wire harness terminals together.
- Turn the ignition switch ON.

CHECK:

Read the temperature value on the hand-held tester.

OK:

Temperature value: 140°C (284°F) or more

OK

**Confirm good connection at sensor.
 If OK, replace water temperature sensor.**

NG

3 Check for open in harness or engine ECU.

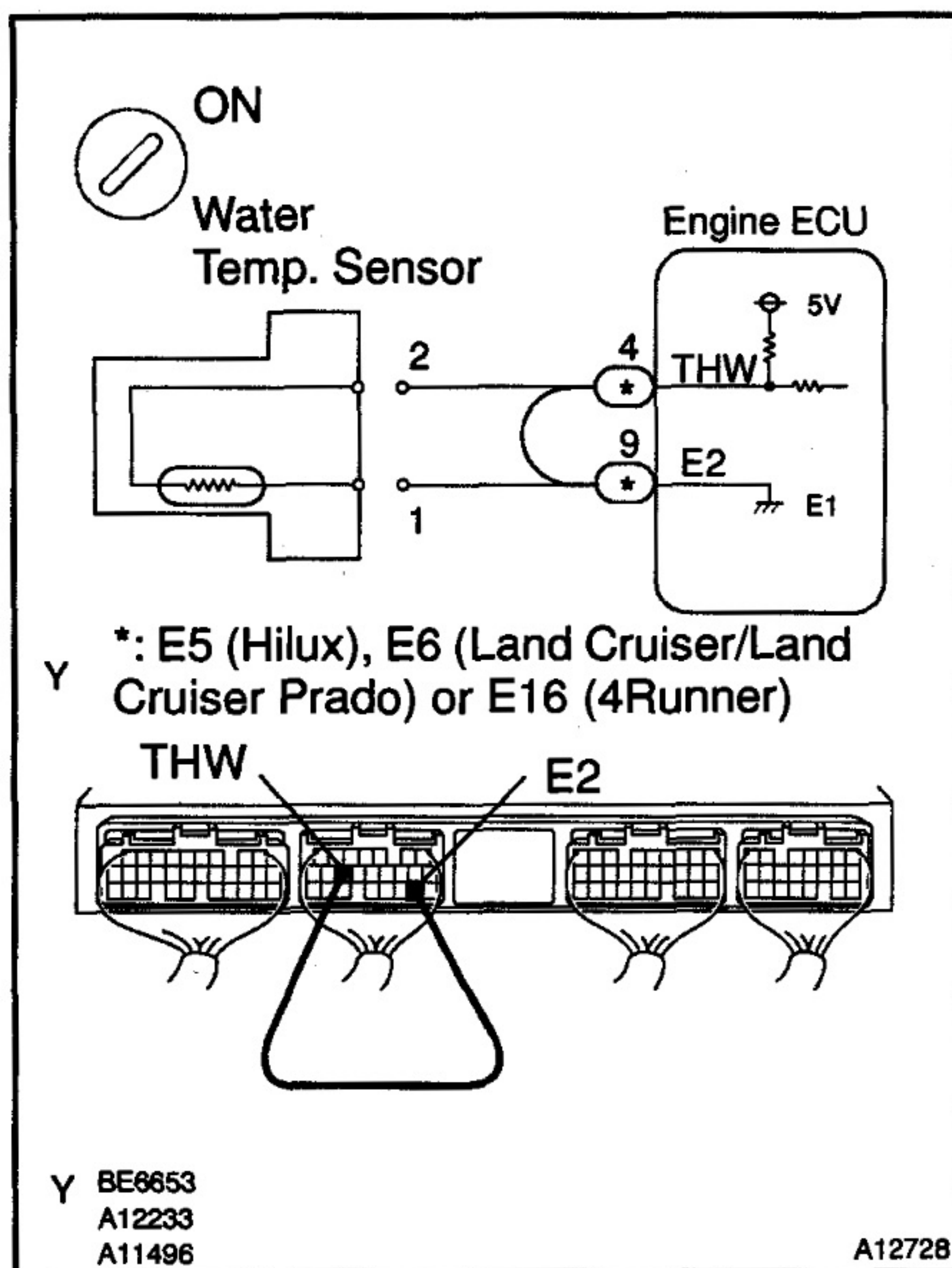

PREPARATION:

- Remove the glove compartment door.
- Connect terminals THW and E2 of the engine ECU connector.

HINT:

Water temperature sensor connector is disconnected. Before checking, do a visual and contact check of the pressure of the engine ECU connector (See page IN-20).

- Turn the ignition switch ON.

CHECK:

Read the temperature value on the hand-held tester.

OK:

Temperature value: 140°C (284°F) or more

OK

Open in harness between terminal E2 or THW, repair or replace harness.

NG

Confirm good connection at engine ECU. If OK, replace engine ECU.

4 Check for short in harness and engine ECU.

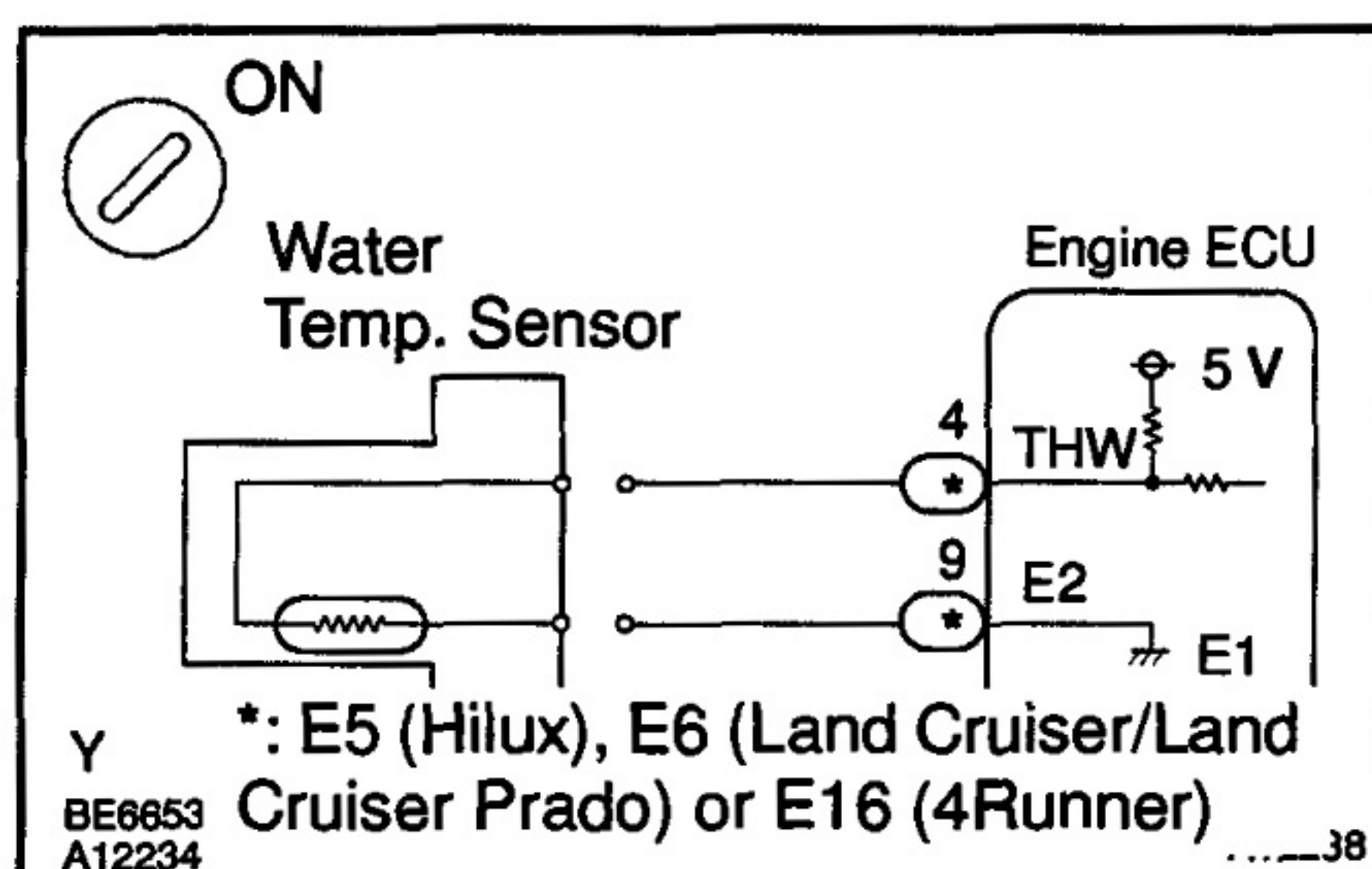

PREPARATION:

- Disconnect the water temperature sensor connector.
- Turn the ignition switch ON.

CHECK:

Read the temperature value on the hand-held tester.

OK:

Temperature value: -40°C (-40°F)

OK

Replace water temperature sensor.

NG

5 Check for short in harness or engine ECU.

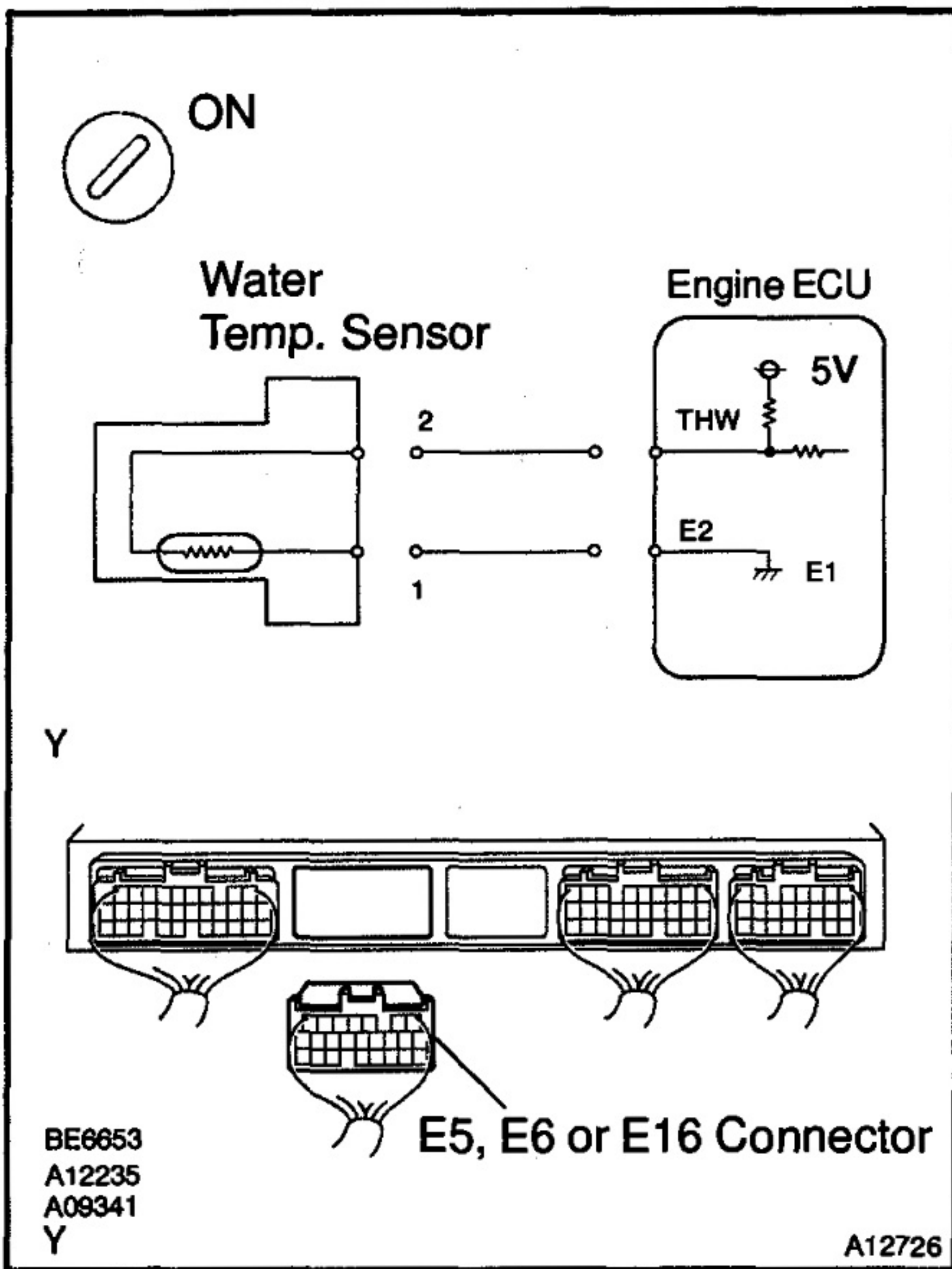

PREPARATION:

- (a) Remove the glove compartment door.
- (b) Disconnect the E5 (Hilux), E6 (Land Cruiser/Land Cruiser Prado) or E16 (4Runner) connector of the engine ECU.

HINT:

Water temperature sensor connector is disconnected.

- (c) Turn the ignition switch ON.

CHECK:

Read the temperature value on the hand-held tester.

OK:

Temperature value: -40°C (-40°F)

OK Repair or replace harness or connector.

NG

Check and replace engine ECU (See page IN-20).

When not using hand-held tester:

1 Check voltage between terminals THW and E2 of engine ECU connector.

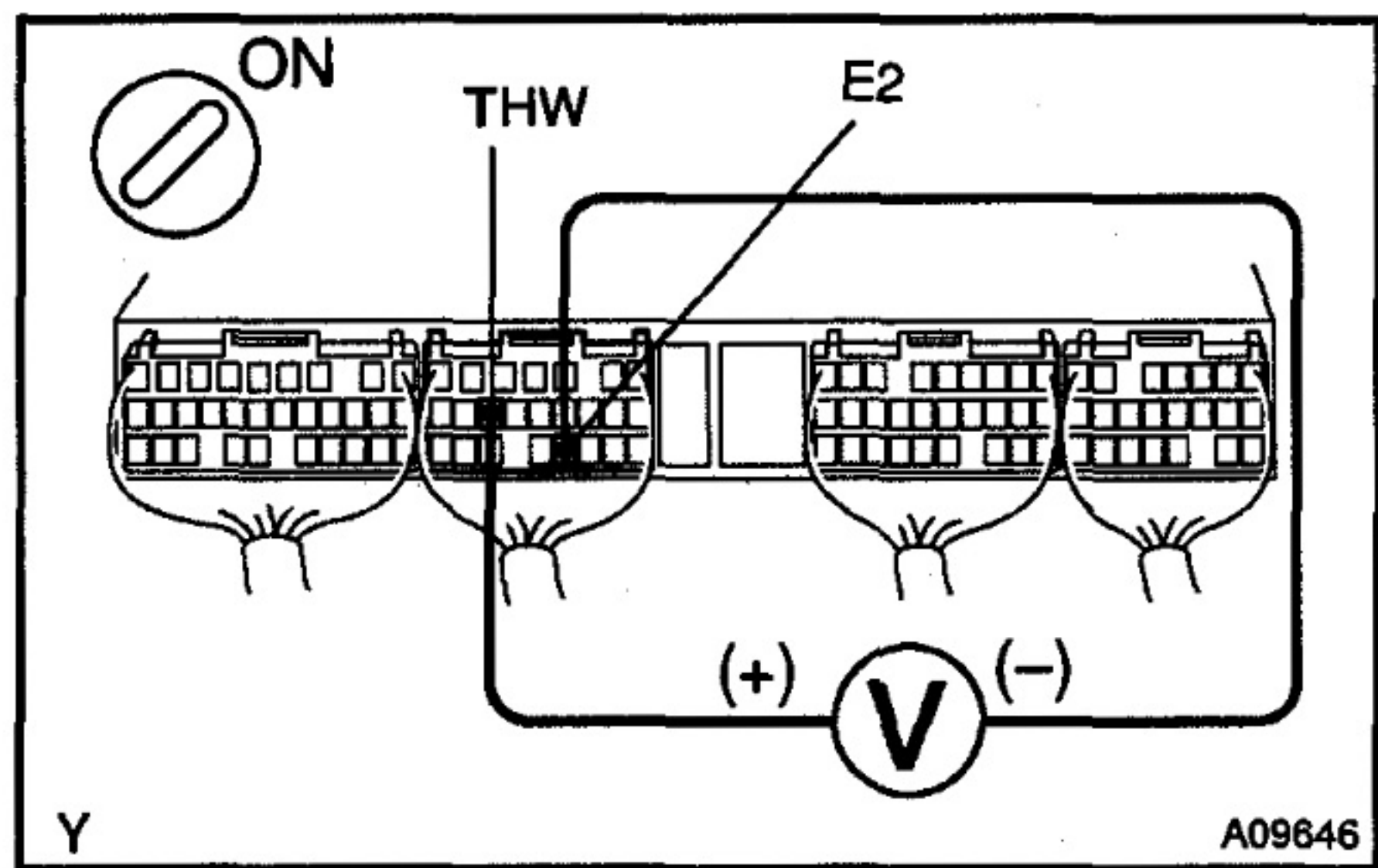

PREPARATION:

- (a) Remove the glove compartment door.
- (b) Turn the ignition switch ON.

CHECK:

Measure the voltage between terminals THW and E2 of the engine ECU connector.

OK:

Water Temp	Voltage
20°C (68°F) (Engine is cool)	0.2 - 3.8 V
80°C (176°F) (Engine is hot)	0.1 - 1.5 V

OK Check for intermittent problems (See page DI-4).

NG

2 Check water temperature sensor (See Pub. No. RM710E, ED section).

NG

Replace water temperature sensor.

OK

3 Check for open and short in harness and connector between engine ECU and water temperature sensor (See page IN-20).

NG

Repair or replace harness or connector.

OK

Check and replace engine ECU.

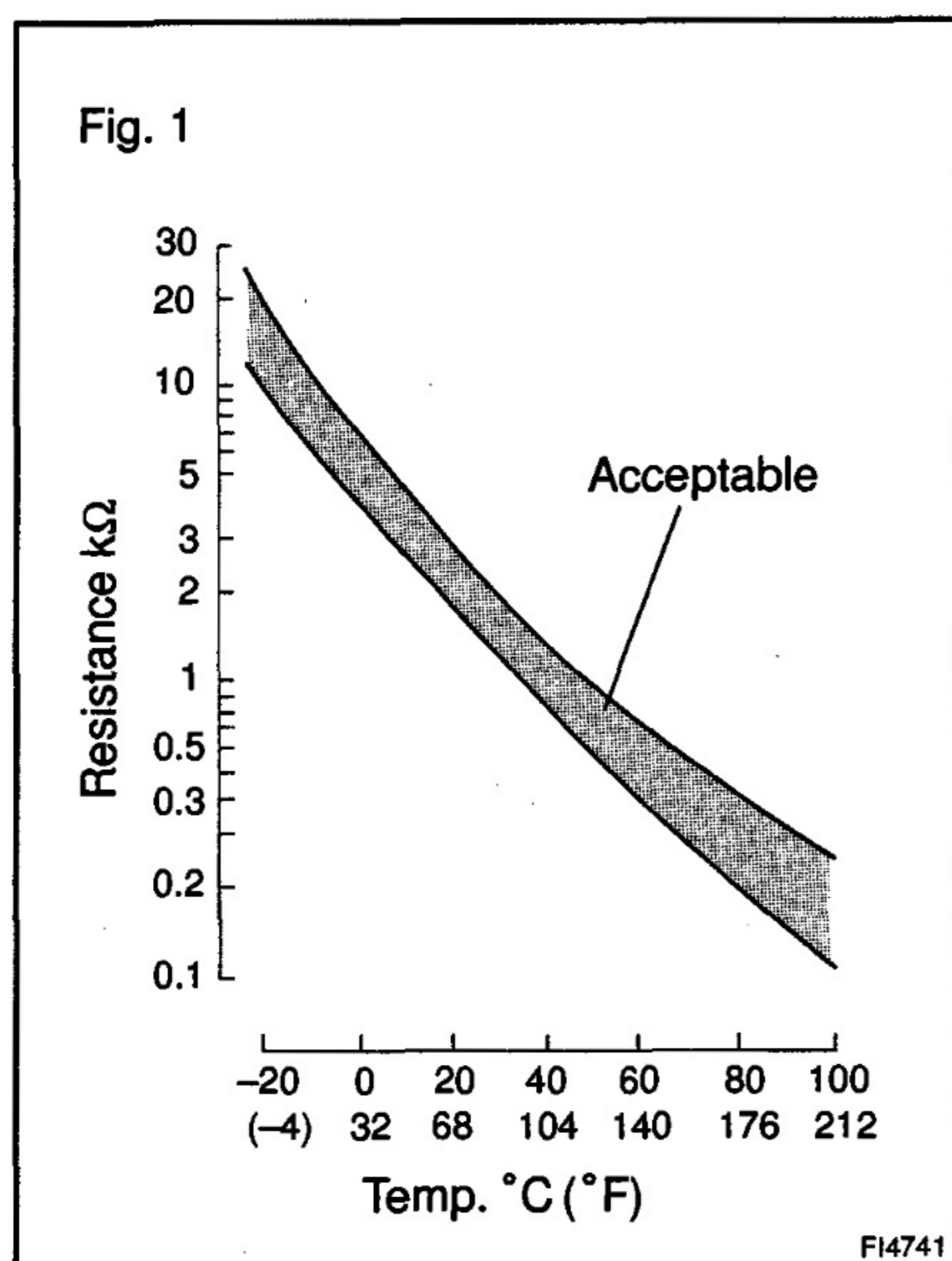
DTC**24****Intake Air Temp. Sensor Circuit Malfunction****CIRCUIT DESCRIPTION**

The intake air temperature sensor is built in the intake manifold and senses the intake air temperature. A thermistor built in the sensor changes the resistance value according to the intake air temperature. The lower the intake air temperature is, the greater the thermistor resistance value becomes, and the higher the intake air temperature is, the lower the thermistor resistance value becomes (See Fig. 1). The intake air temperature sensor is connected to the engine ECU. The 5 V power source voltage in the engine ECU is applied to the intake air temperature sensor from terminal THA via a resistor R. That is resistor R and the intake air temperature sensor are connected in series. When the resistance value of the intake air temperature sensor changes, the potential at terminal THA also changes. Based on this signal, the engine ECU increases the fuel injection volume to improve drivability during cold engine operation.

DTC No.	DTC Detection Condition	Trouble Area
24	Open or short in intake air temp. sensor circuit for 0.5 sec. or more	<ul style="list-style-type: none"> • Open or short in intake air temp. sensor circuit • Intake air temp. sensor • Engine ECU

HINT:

After confirming DTC 24, use the hand-held tester to confirm the water temperature from the CURRENT DATA.

Displayed Temperature	Malfunction
-40°C (-40°F)	Open circuit
140°C (284°F) or more	Short circuit

WIRING DIAGRAM

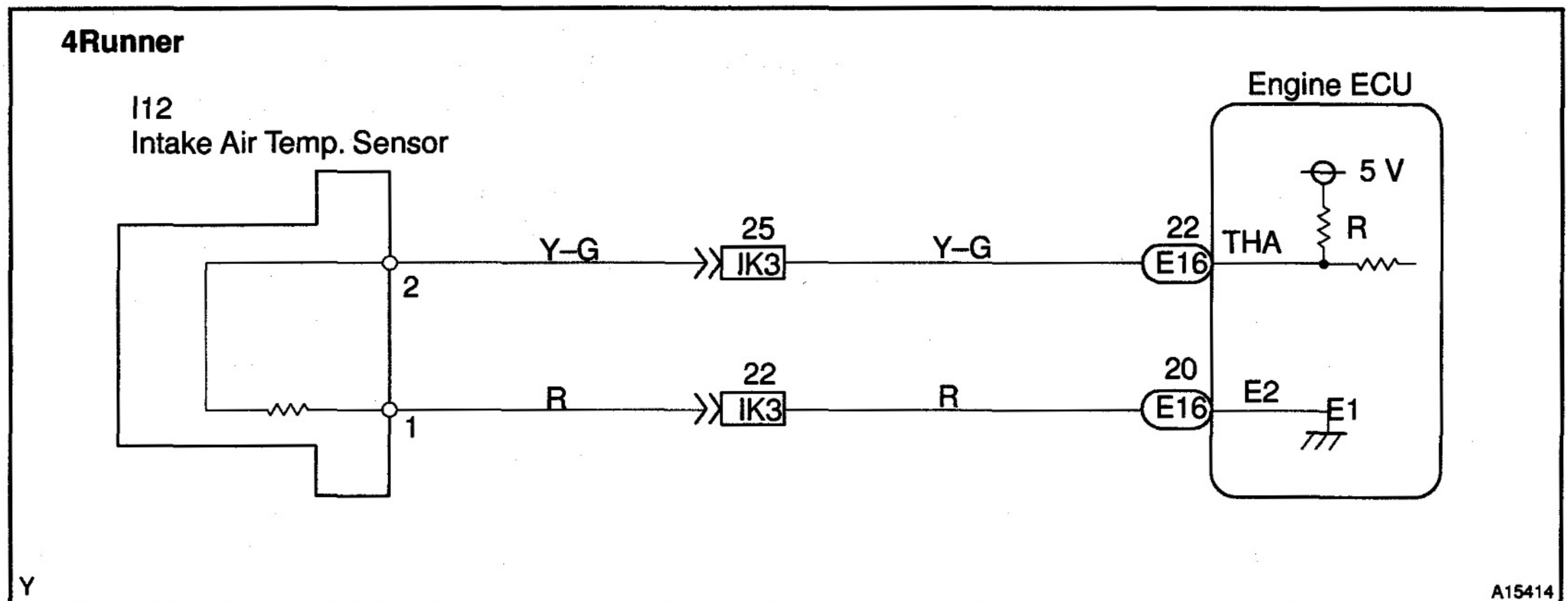
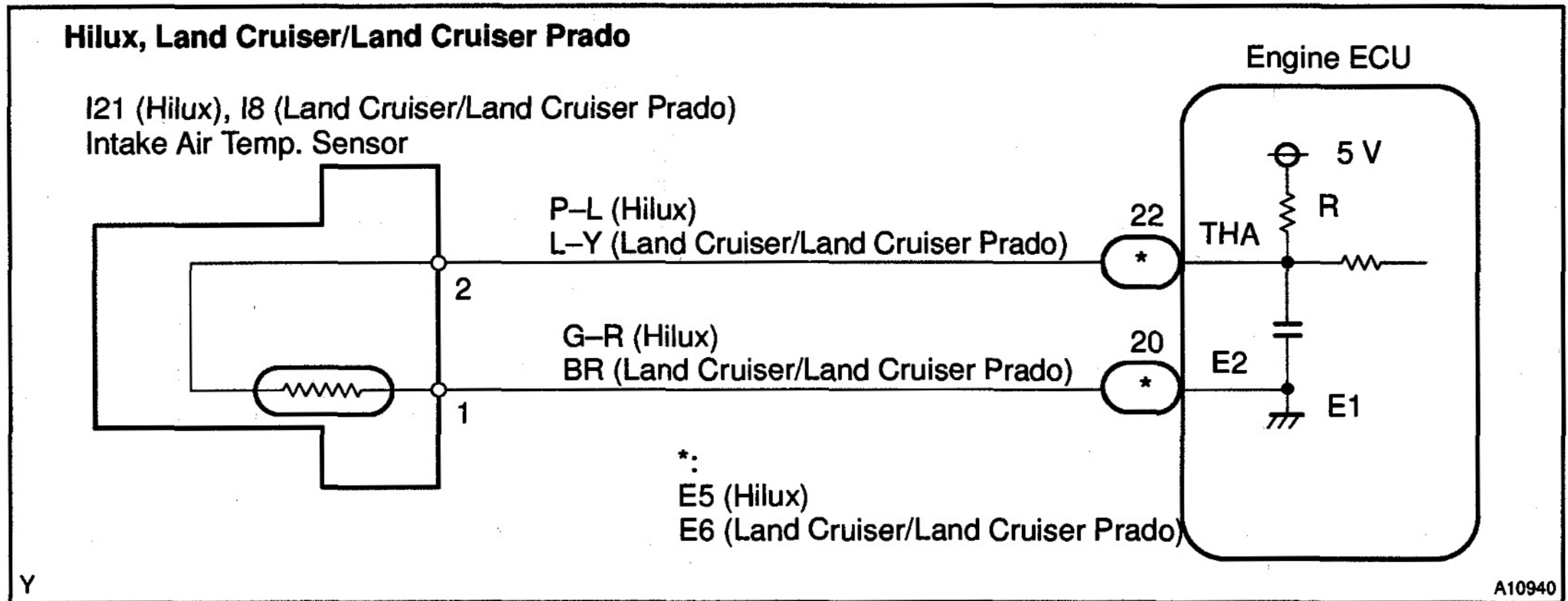

INSPECTION PROCEDURE

HINT:

- If DTC22, 24, 35 and 39 are output simultaneously, E2 (sensor ground) may be open.
- Read freeze frame data using hand-held tester, as freeze frame data records the engine conditions when a malfunction is detected. When troubleshooting, it is useful for determining whether the vehicle was running or stopped, the engine was warmed up or not, the air-fuel ratio was lean or rich, etc. at the time of the malfunction.

When using hand-held tester:

1	Connect hand-held tester, and read value of water temperature.
---	---

PREPARATION:

- Connect the hand-held tester to the DLC3.
- Turn the ignition switch ON and push the hand-held tester main switch ON.

CHECK:

Read the temperature value on the hand-held tester.

OK:

Same value as the actual intake air temperature.

HINT:

- If there is open circuit, hand-held tester indicates -40°C (-40°F).
- If there is short circuit, hand-held tester indicates 140°C (284°F) or more.

NG

-40°C (-40°F) ... Go to step 2.
 140°C (284°F) or more ... Go to step 4.

OK

Check for intermittent problems (See page DI-4).

2

Check for open in harness or engine ECU.

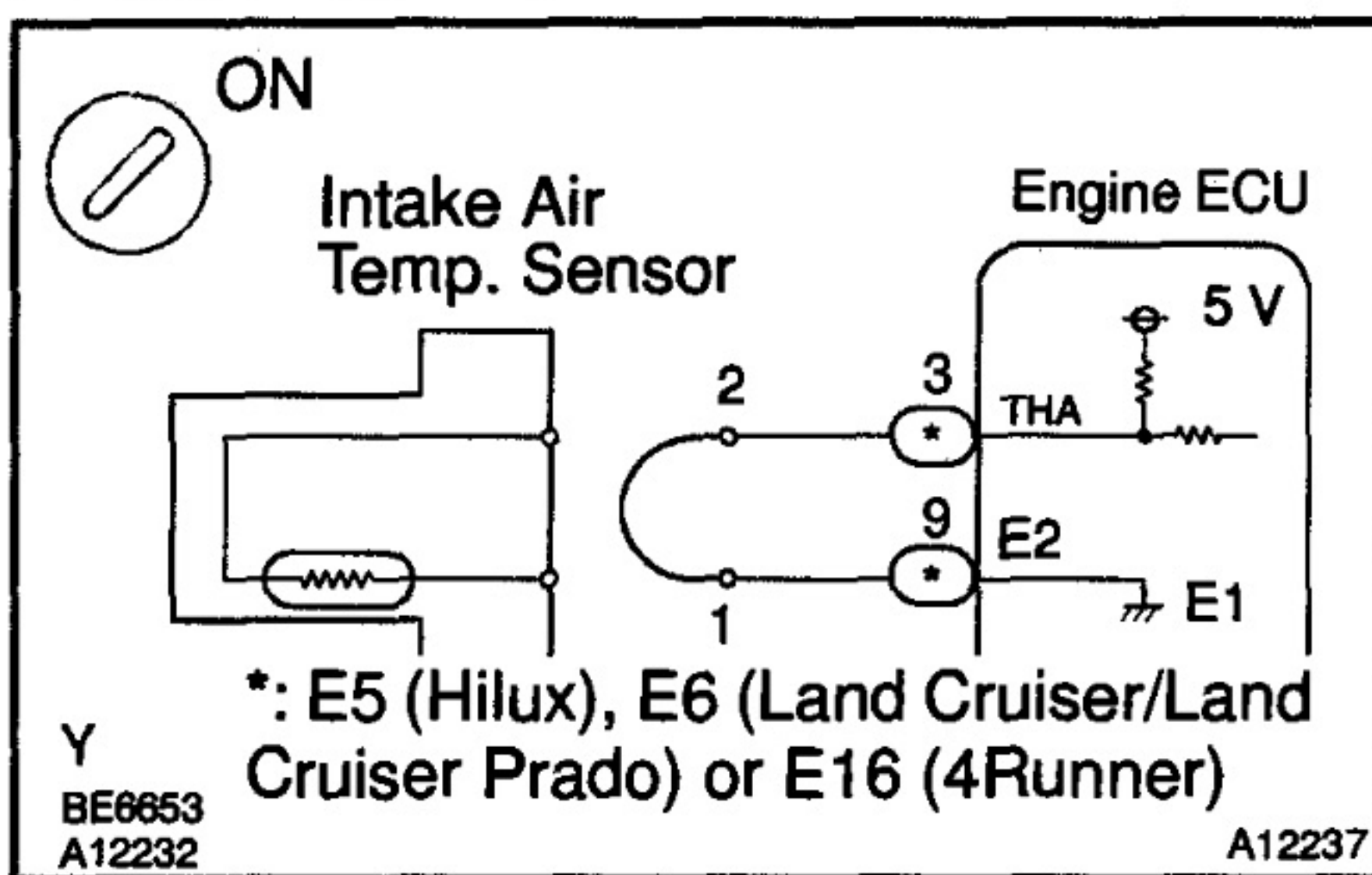
**PREPARATION:**

- Disconnect the intake air temperature sensor connector.
- Connect the sensor wire harness terminals together.
- Turn the ignition switch ON.

CHECK:

Read the temperature value on the hand-held tester.

OK:

Temperature value: 140°C (284°F) or more

OK

Confirm good connection at sensor.
 If OK, replace intake air temperature sensor.

NG

3 Check for open in harness or engine ECU.

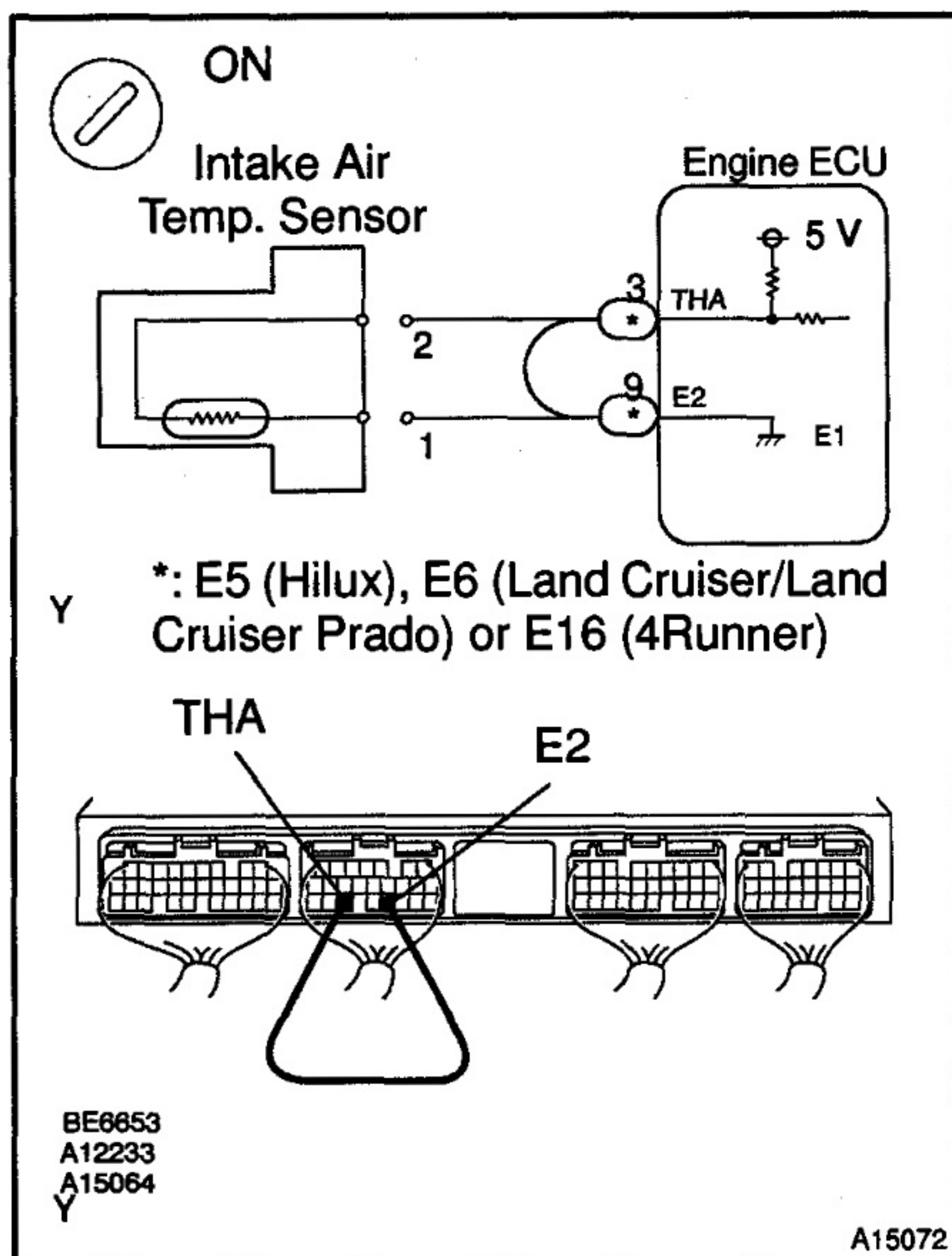

PREPARATION:

- Remove the glove compartment door.
- Connect between terminals THA and E2 of the engine ECU connector.

HINT:

Intake air temperature sensor connector is disconnected. Before checking, do a visual and contact check of the pressure of the engine ECU connector (See page IN-20).

- Turn the ignition switch ON.

CHECK:

Read the temperature value on the hand-held tester.

OK:

Temperature value: 140°C (284°F) or more

OK

Open in harness between terminal E2 or THA, repair or replace harness.

NG

Confirm good connection at engine ECU. If OK, replace engine ECU.

4 Check for short in harness and engine ECU.

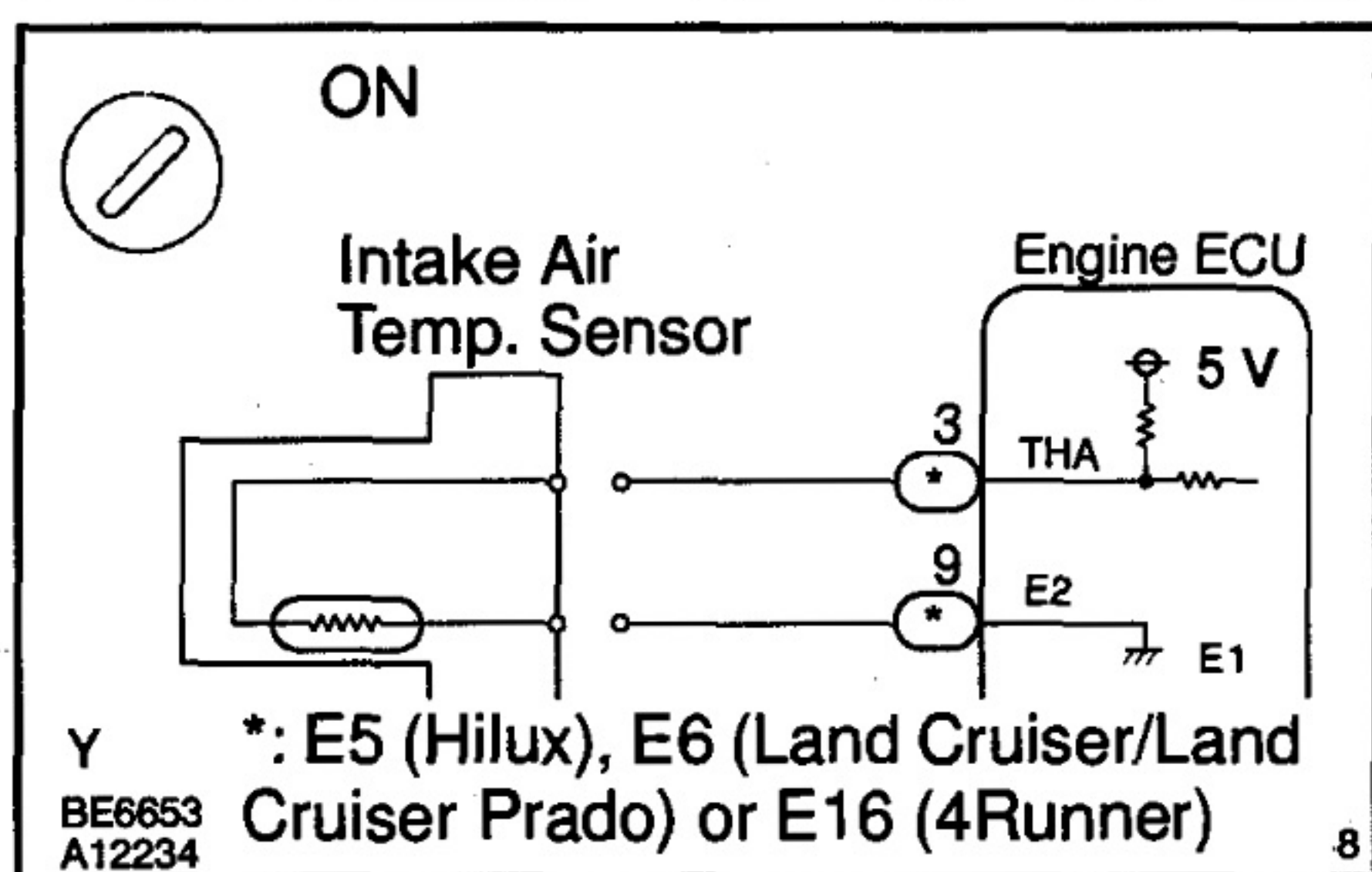

PREPARATION:

- Disconnect the intake air temperature sensor connector.
- Turn the ignition switch ON.

CHECK:

Read the temperature value on the hand-held tester.

OK:

Temperature value: -40°C (-40°F)

OK

Replace intake air temperature sensor.

NG

5 Check for short in harness or engine ECU.

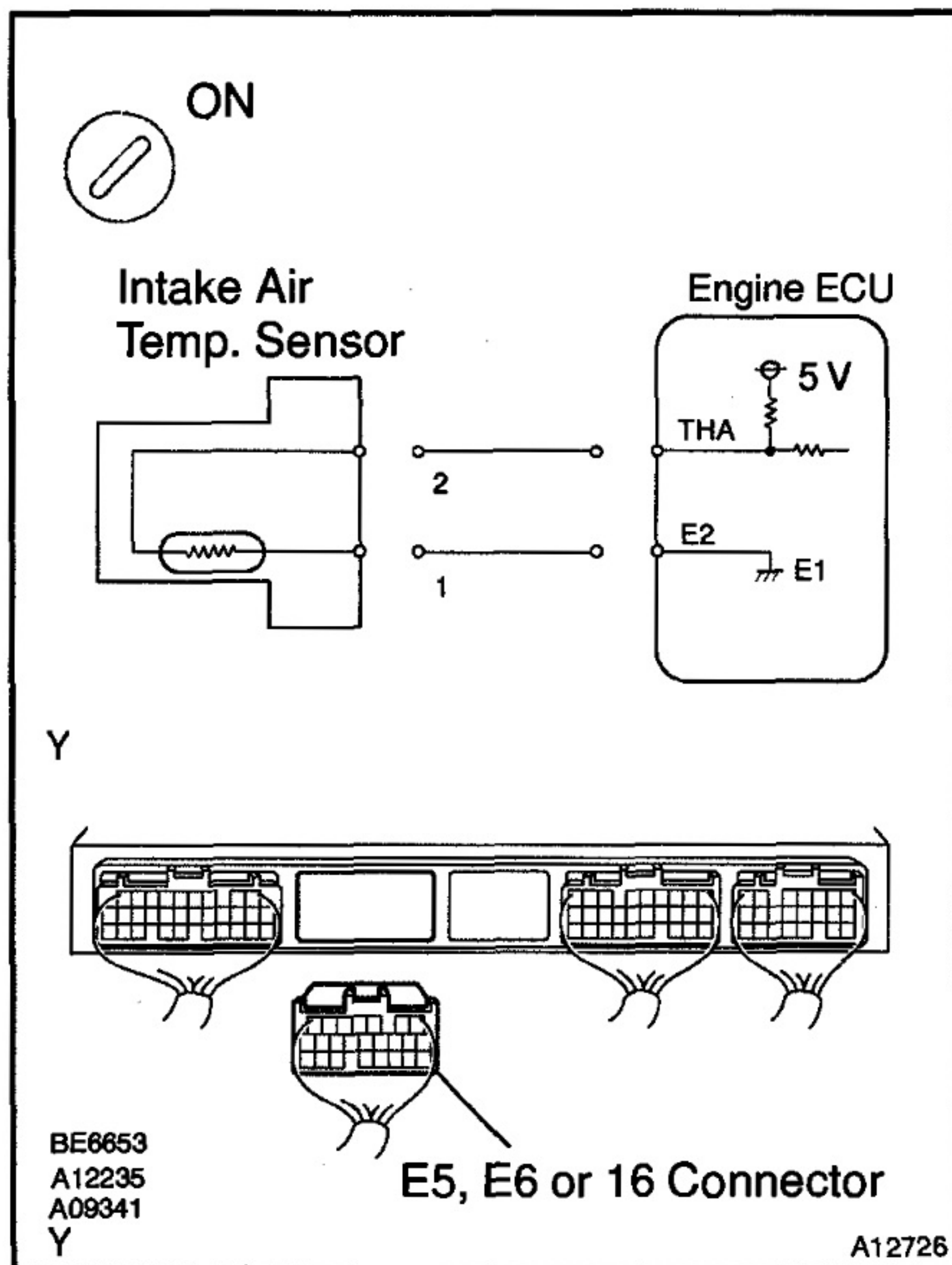

PREPARATION:

- Remove the glove compartment door.
- Disconnect the E5 (Hilux), E6 (Land Cruiser/Land Cruiser Prado) or E16 (4Runner) connector of the engine ECU.

HINT:

Intake air temperature sensor connector is disconnected.

- Turn the ignition switch ON.

CHECK:

Read the temperature value on the hand-held tester.

OK:

Temperature value: -40°C (-40°F)

OK

Repair or replace harness or connector.

NG

Check and replace engine ECU (See page IN-20).

When not using hand-held tester:

1 Check voltage between terminals THA and E2 of engine ECU connector.

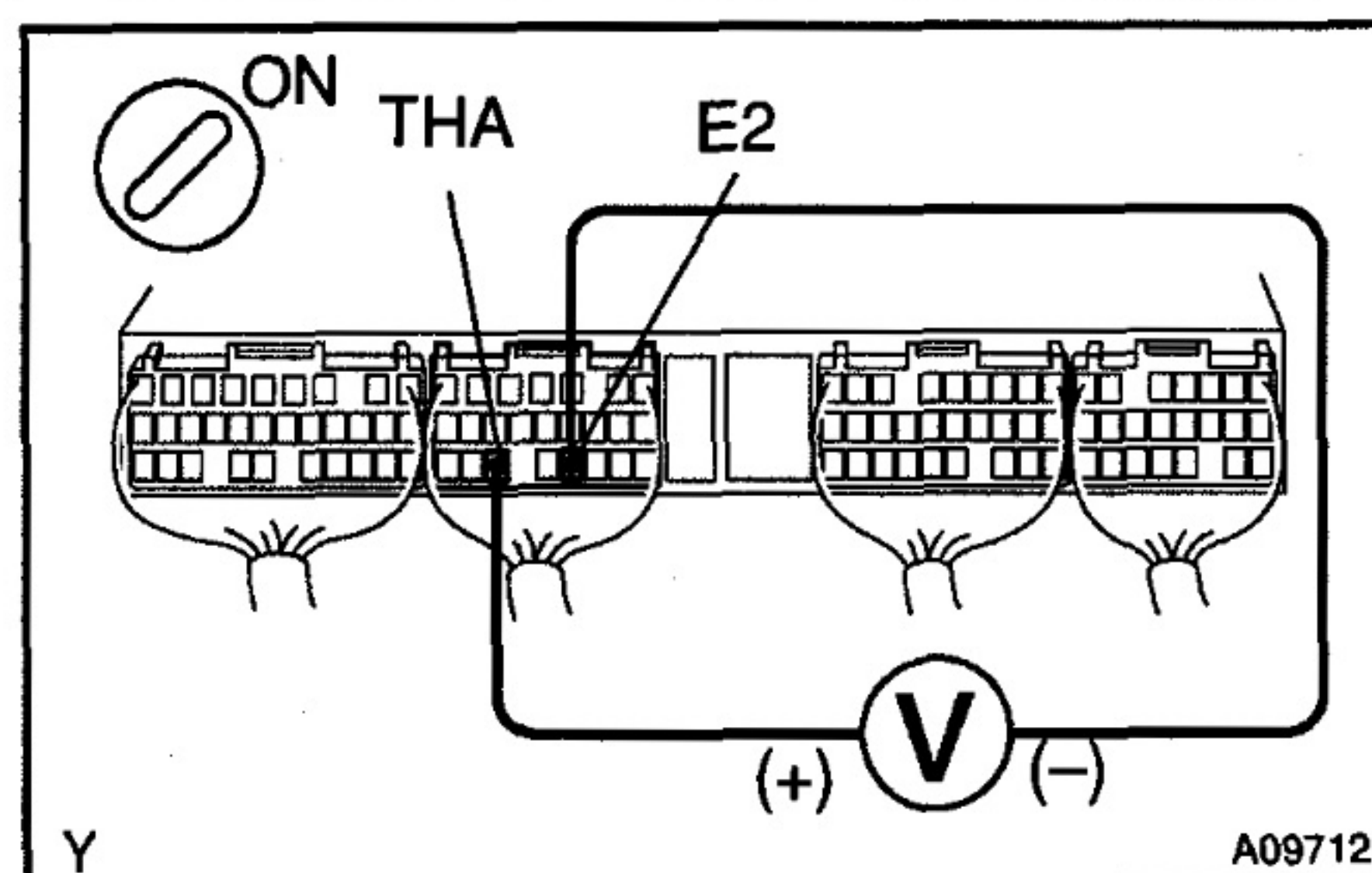

PREPARATION:

- Remove the glove compartment door.
- Turn the ignition switch ON.

CHECK:

Measure the voltage between terminals THA and E2 of the engine ECU connector.

OK:

Intake Air Temp.	Voltage
20°C (68°F) (Engine is cool)	0.2 – 3.8 V
80°C (176°F) (Engine is hot)	0.1 – 1.5 V

OK

Check for intermittent problems (See page DI-4).

NG**2** Check intake air temperature sensor (See page ED-13).**NG**

Replace intake air temperature sensor.

OK**3** Check for open and short in harness and connector between engine ECU and intake air temperature sensor (See page IN-20).**NG**

Repair or replace harness or connector.

OK

Check and replace engine ECU.

DTC	32	Injection Pump Correction System Malfunction
------------	-----------	---

CIRCUIT DESCRIPTION

The correction system is the one to correct a small change between each injection pumps.

DTC No.	DTC Detection Condition	Trouble Area
32	Open or short in injection pump correction unit circuit	<ul style="list-style-type: none"> • Open or short in injection pump correction unit circuit • Injection pump correction unit • Engine ECU

WIRING DIAGRAM

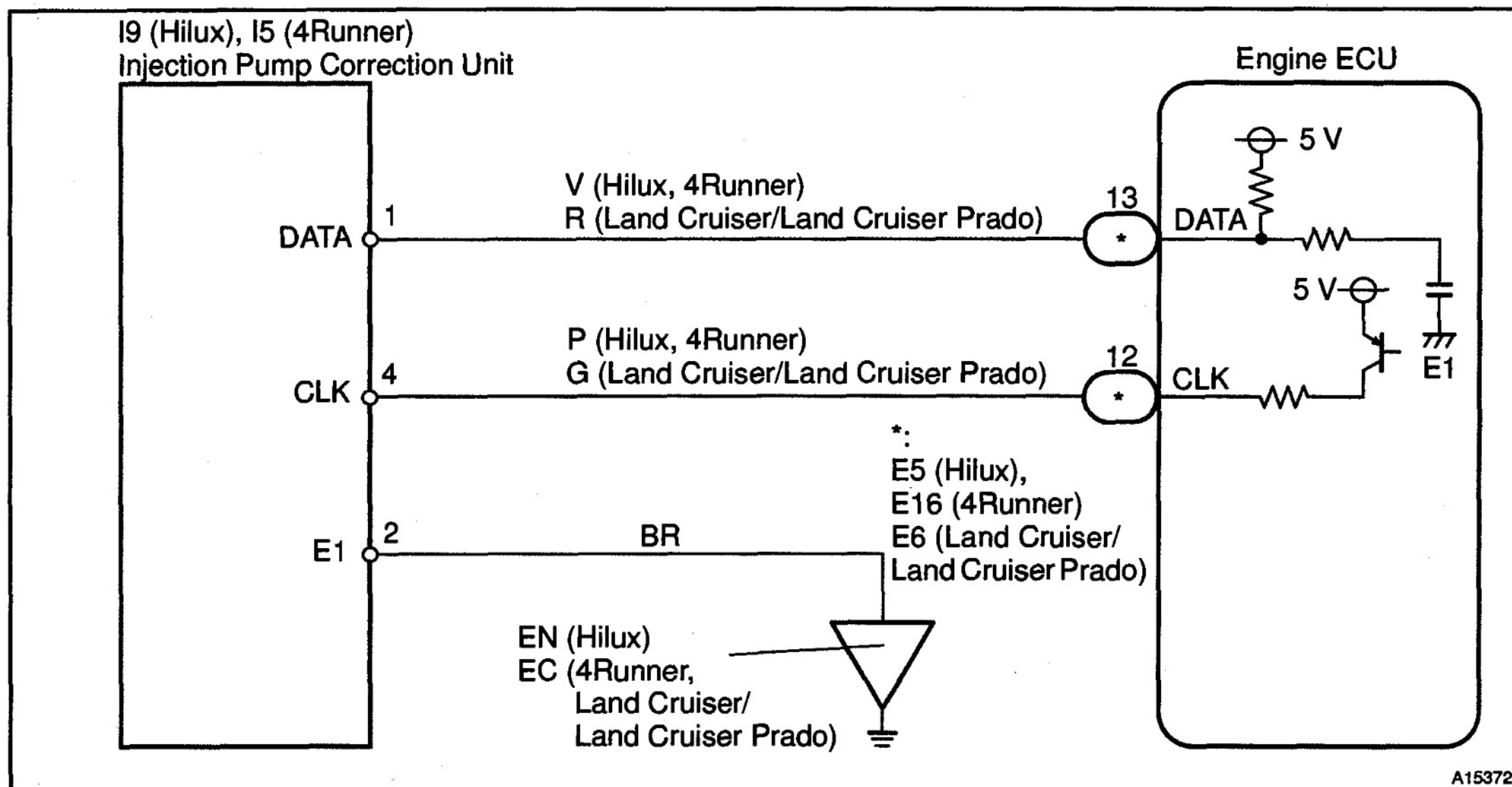

INSPECTION PROCEDURE

HINT:

Read freeze frame data using hand-held tester, as freeze frame data records the engine conditions when a malfunction is detected. When troubleshooting, it is useful for determining whether the vehicle was running or stopped, the engine was warmed up or not, the air-fuel ratio was lean or rich, etc. at the time of the malfunction.

1	Check for open and short in harness and connector between engine ECU and injection pump correction unit (See page IN-20).
---	--

NG

Repair or replace harness or connector.

OK

2

Try to change injection pump correction unit to another one.**PREPARATION:**

- (a) Remove the injection pump correction unit from the injection pump.
- (b) Install another injection pump correction unit.
- (c) Clear the DTC.
- (d) Turn the ignition switch ON.

CHECK:

Read the DTC again.

OK:

The DTC32 does not output.

OK

Check and replace injection pump (See page FU-5).

NG

Check and replace engine ECU (See page IN-20).

DTC	35	Turbo Pressure Sensor Circuit Malfunction
------------	-----------	--

CIRCUIT DESCRIPTION

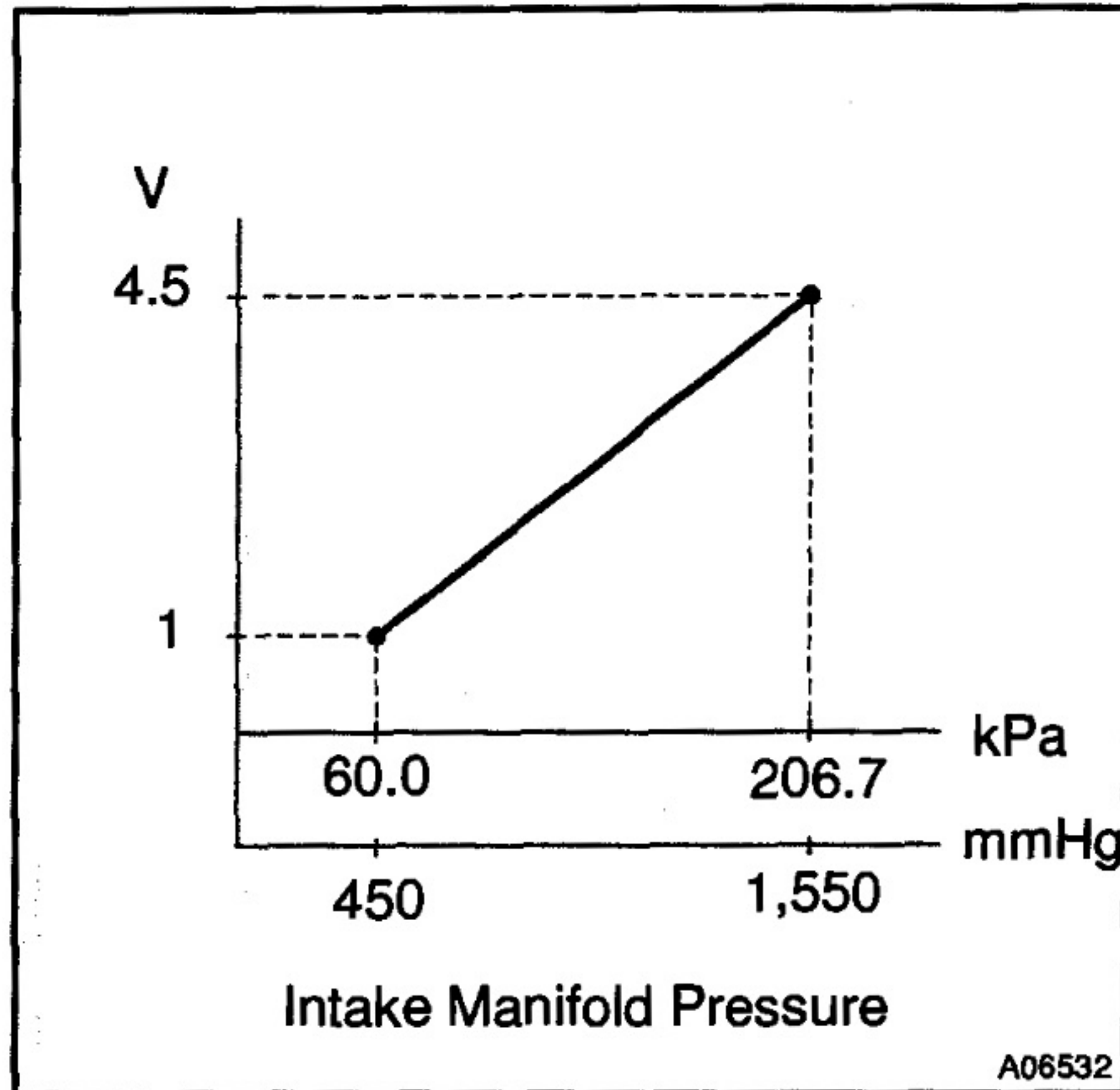

The turbo pressure sensor is connected to the intake manifold. The engine ECU detects the intake manifold pressure as a voltage by the sensor. The engine ECU uses the intake manifold pressure signal for a correction of the injection volume control and injection timing control.

The VSV for turbo pressure sensor switches the atmosphere applied to the turbo pressure sensor to the intake manifold pressure. The turbo pressure sensor monitors both of the atmospheric pressure and intake manifold pressure and transmits the output voltage to the engine ECU, and the engine ECU uses this atmospheric pressure value for correcting the injection volume.

DTC No.	DTC Detection Condition	Trouble Area
35	Open or short in turbo pressure sensor circuit for 2 sec. or more	<ul style="list-style-type: none"> • Open or short in turbo pressure sensor circuit • Turbo pressure sensor • Vacuum hose disconnected or blocked • Engine ECU

HINT:

After confirming DTC 35, use the hand-held tester to confirm the intake manifold pressure from the CURRENT DATA.

Intake Manifold Pressure (kPa)	Malfunction
Approx. 0	<ul style="list-style-type: none"> • PIM circuit short
206.7 or more	<ul style="list-style-type: none"> • VC circuit open or short • PIM circuit open • E2 circuit open

WIRING DIAGRAM

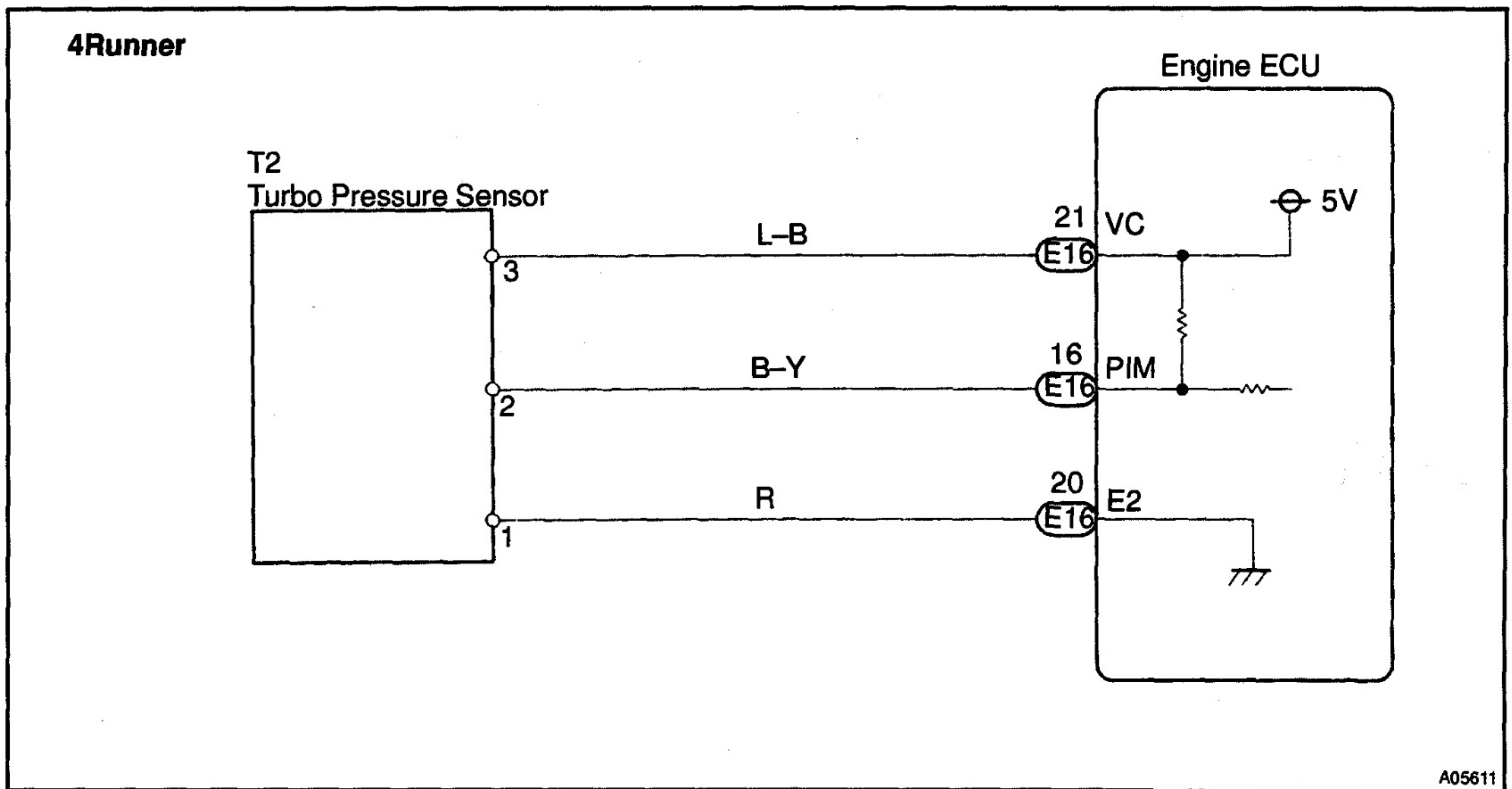
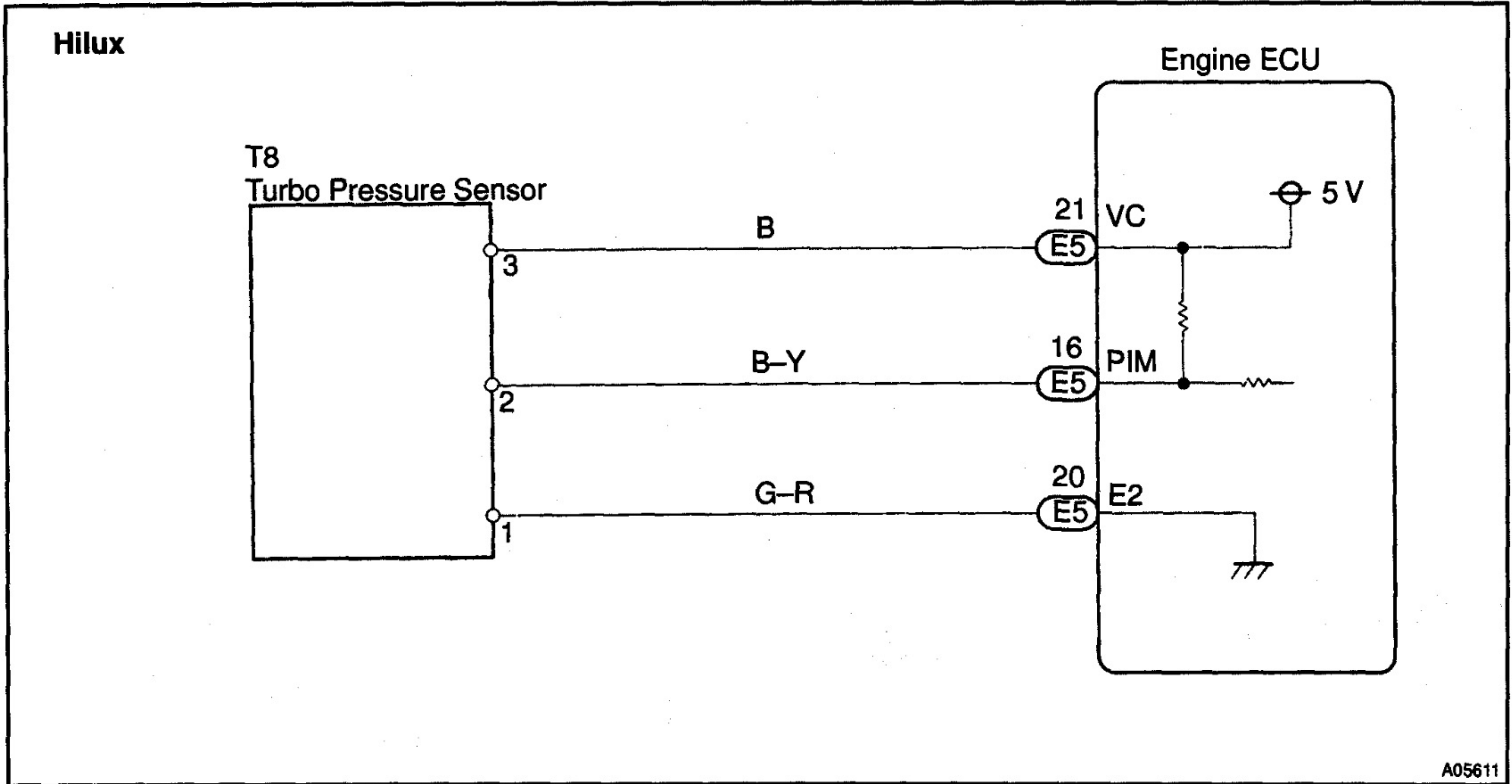

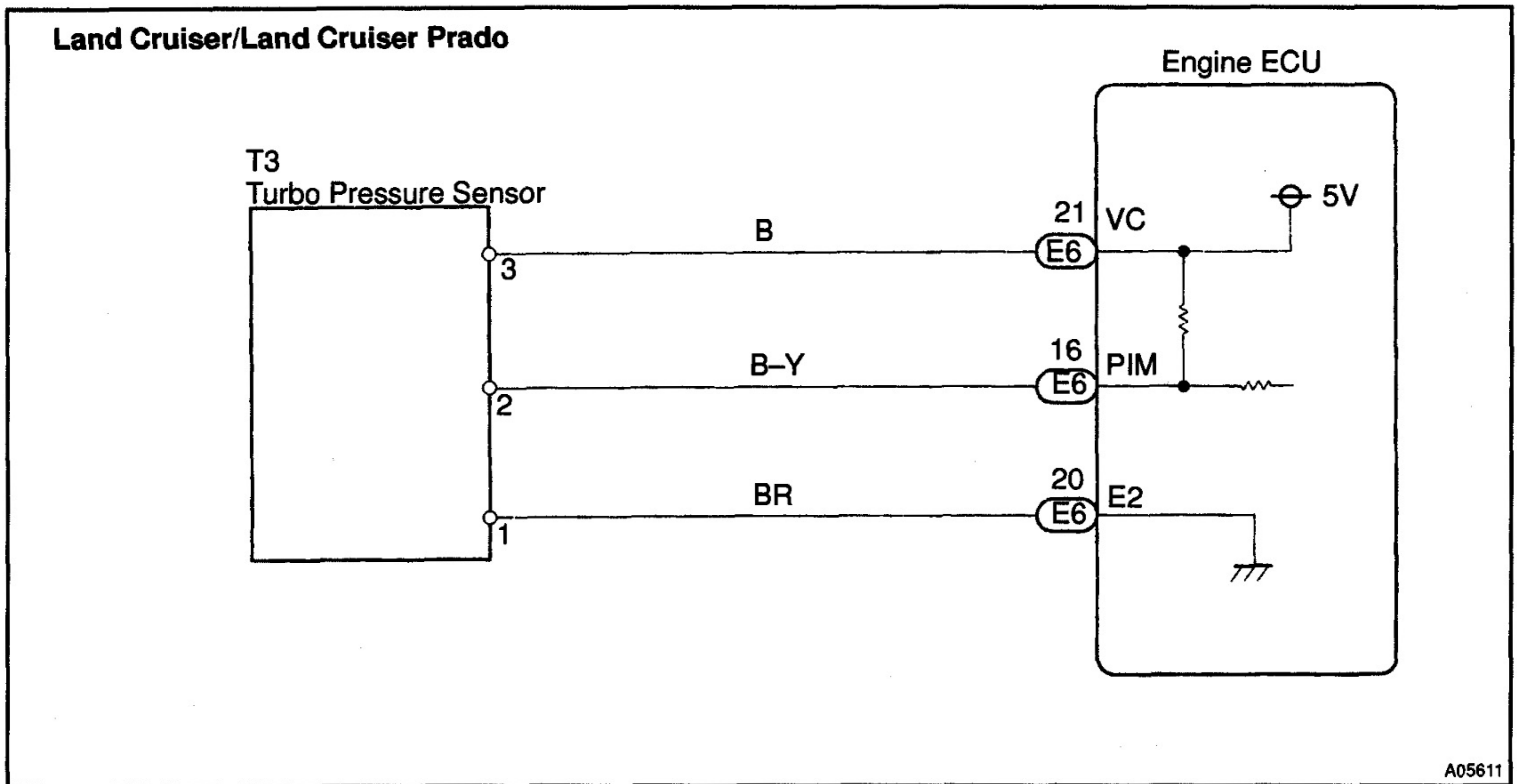

INSPECTION PROCEDURE

HINT:

- If DTC22, 24, 35 and 39 are output simultaneously, E2 (sensor ground) may be open.
- Read freeze frame data using hand-held tester, as freeze frame data records the engine conditions when a malfunction is detected. When troubleshooting, it is useful for determining whether the vehicle was running or stopped, the engine was warmed up or not, the air-fuel ratio was lean or rich, etc. at the time of the malfunction.

When using hand-held tester:

1	Connect hand-held tester, and read value of intake manifold pressure.
---	--

PREPARATION:

- Connect the hand-held tester to the DLC3.
- Turn the ignition switch ON and push the hand-held tester main switch ON.

CHECK:

Read the value of the intake manifold pressure on the hand-held tester.

OK:

Same as atmospheric pressure.

OK

Go to step 5.

NG

2 Check turbo pressure sensor (See page ED-14).

NG

Replace turbo pressure sensor.

OK

3 Check voltage between terminals VC and E2 of engine ECU connector.

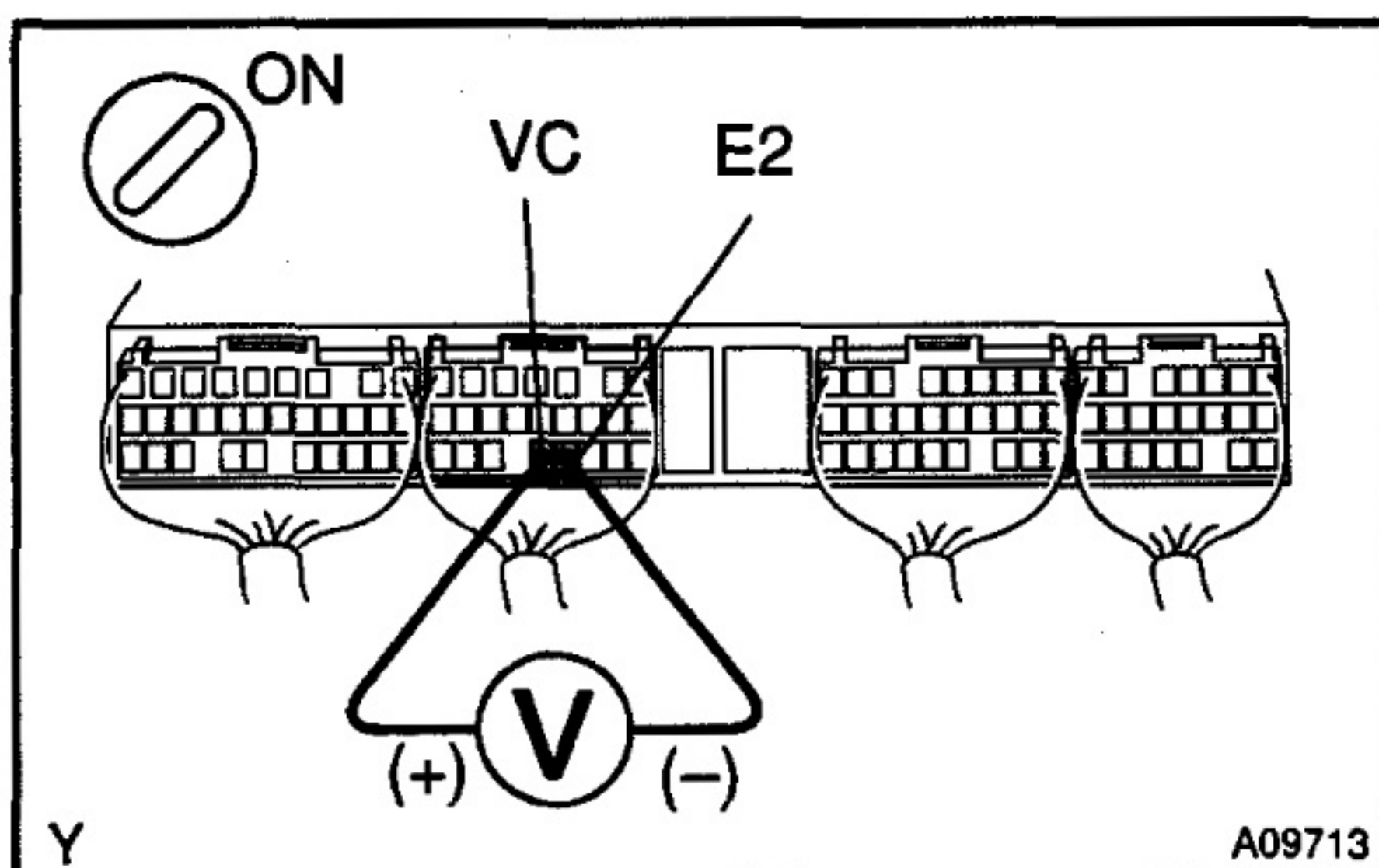

PREPARATION:

- (a) Remove the glove compartment door.
- (b) Turn the ignition switch ON.

CHECK:

Measure the voltage between terminals VC and E2 of the engine ECU connector.

OK:

Voltage: 4.5 - 5.5 V

NG

Check and replace engine ECU (See page IN-20).

OK

4 Check voltage between terminals PIM and E2 of engine ECU connector.

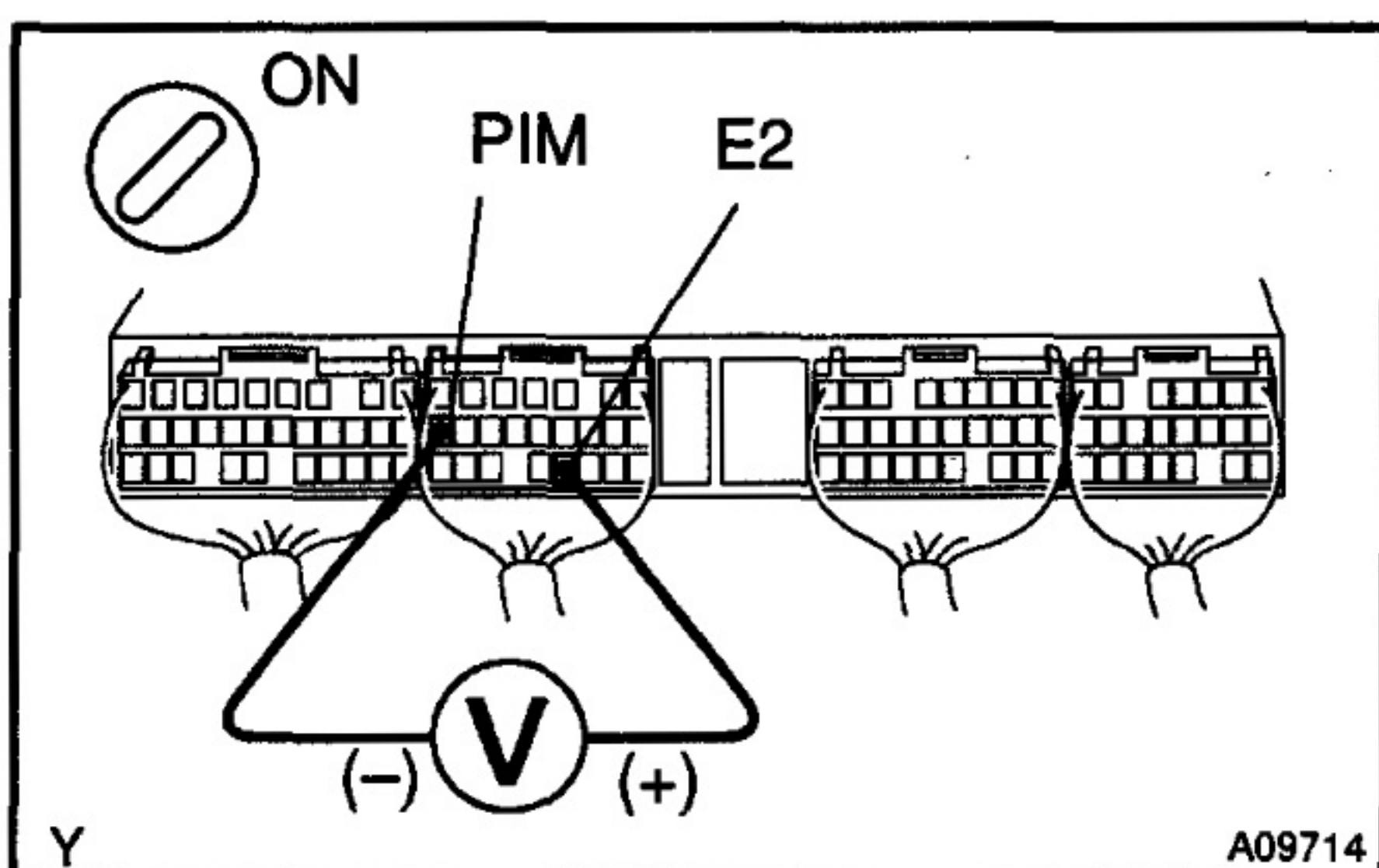

PREPARATION:

- (a) Remove the glove compartment door.
- (b) Turn the ignition switch ON.

CHECK:

Measure the voltage between terminals PIM and E2 of the engine ECU connector.

OK:

Voltage: 1.0 - 2.2 V

OK

Check and replace engine ECU (See page IN-20).

NG

Check for open and short in harness and connector between engine ECU and turbo pressure sensor (See page IN-20).

5 Check connection of vacuum hose between turbo pressure sensor and intake manifold.

NG

Repair or replace.

OK

6 Check for open and short in harness and connector between engine ECU and ECD main relay (Marking: ECD) (See page IN-20).

NG

Repair of replace harness or connector.

OK

Check and replace engine ECU.

When not using hand-held tester:

1 Check turbo pressure sensor (See page ED-14).

NG

Replace turbo pressure sensor.

OK

2 Check voltage between terminals VC and E2 of engine ECU connector.

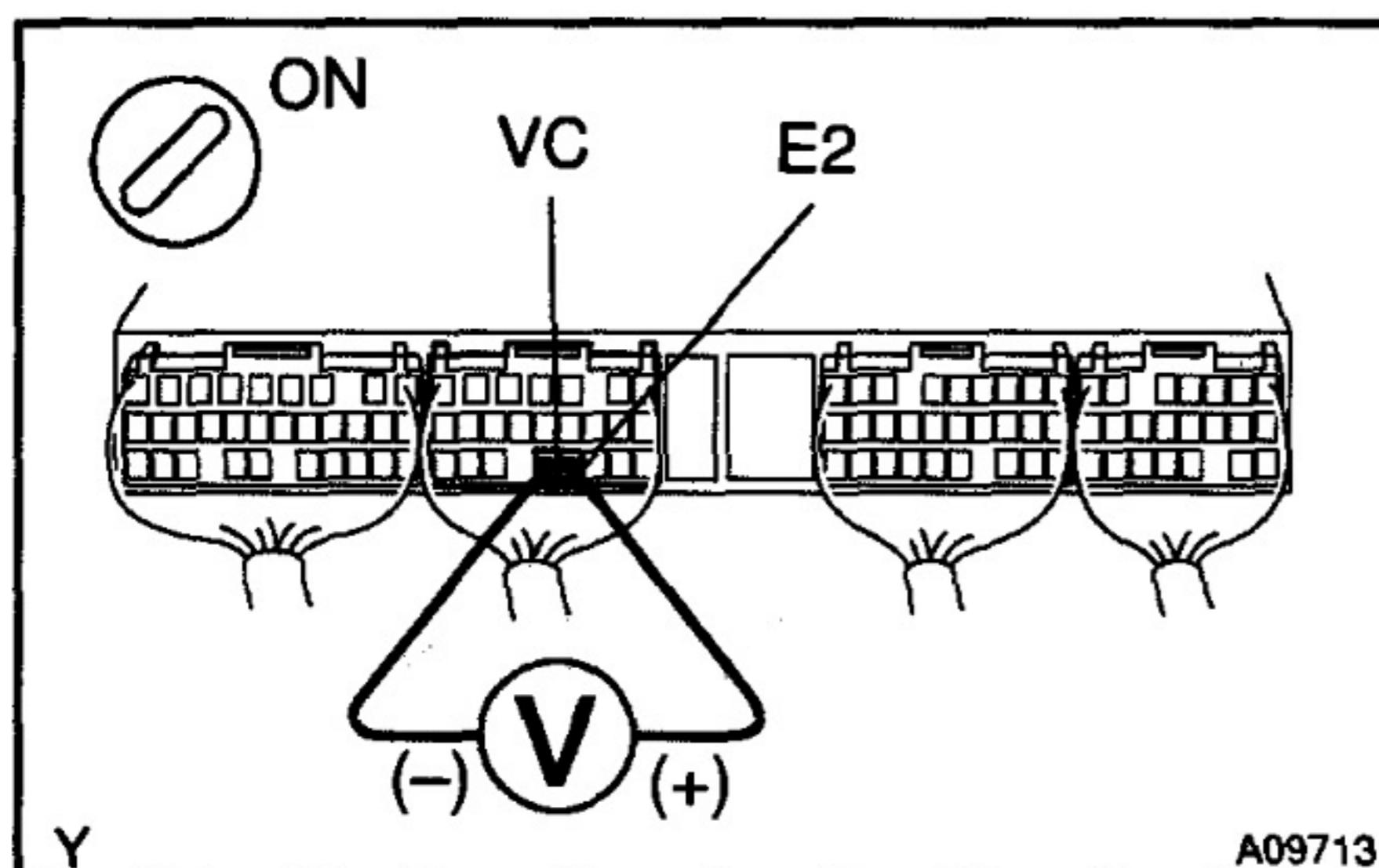

PREPARATION:

- Remove the glove compartment door.
- Turn the ignition switch ON.

CHECK:

Measure the voltage between terminals VC and E2 of the engine ECU connector.

OK:

Voltage: 4.5 - 5.5 V

NG

Check and replace engine ECU (See page IN-20).

OK

3 Check voltage between terminals PIM and E2 of engine ECU connector.

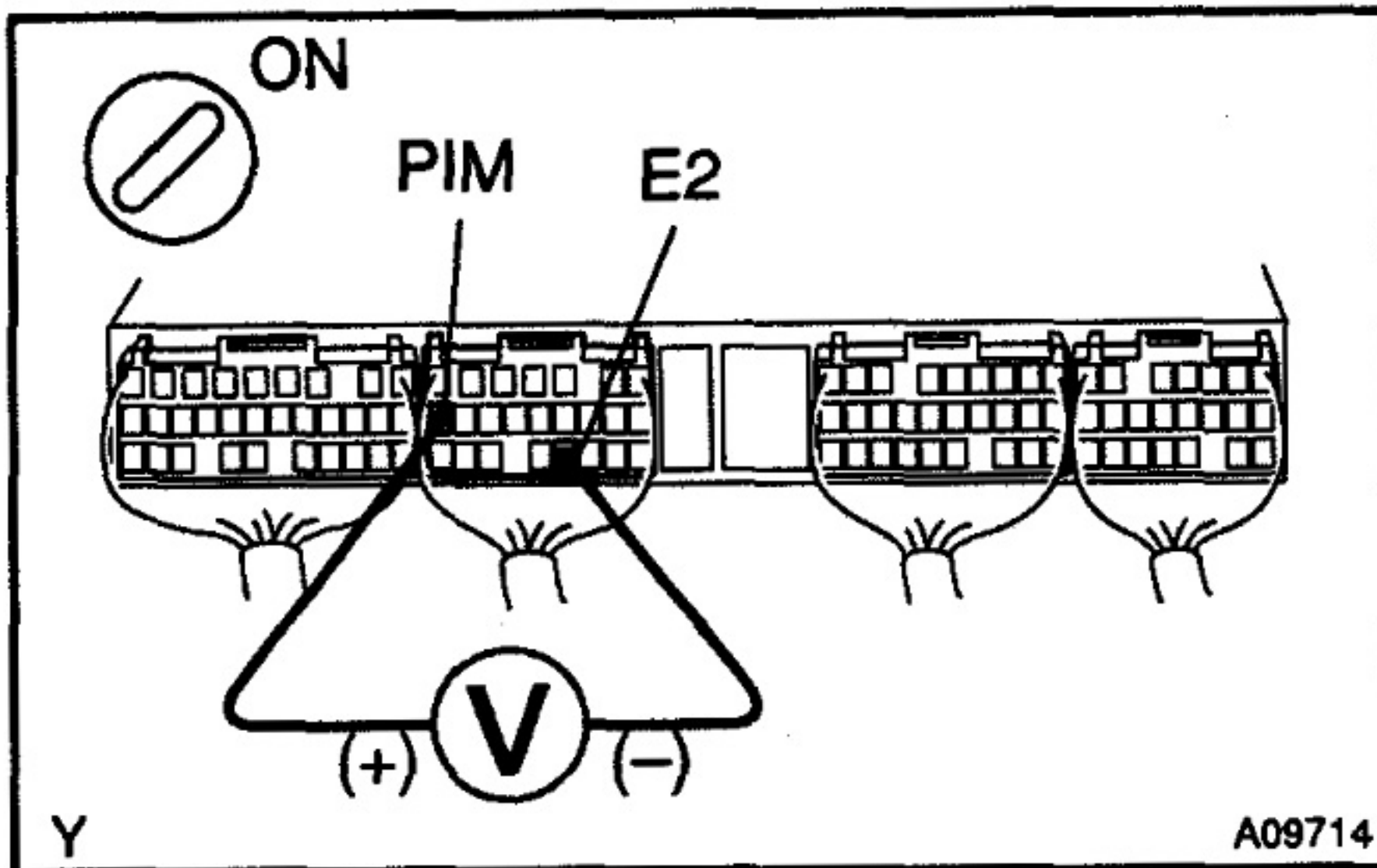
**PREPARATION:**

- (a) Remove the glove compartment door.
- (b) Turn the ignition switch ON.

CHECK:

Measure the voltage between terminals PIM and E2 of the engine ECU connector.

OK:

Voltage: 1.0 - 2.2 V

OK

Check and replace engine ECU (See page IN-20).

NG

4 Check for open and short in harness and connector between engine ECU and turbo pressure sensor (See page IN-20).

NG

Repair or replace harness or connector.

OK

5 Check connection of vacuum hose between turbo pressure sensor and intake manifold.

NG

Repair or replace.

OK

6 Check for open and short in harness and connector between engine ECU and ECD main relay (Marking: ECD) (See page IN-20).

NG

Repair or replace harness or connector.

OK

Check and replace engine ECU.

DTC	39	Fuel Temp. Sensor Circuit Malfunction
------------	-----------	--

CIRCUIT DESCRIPTION

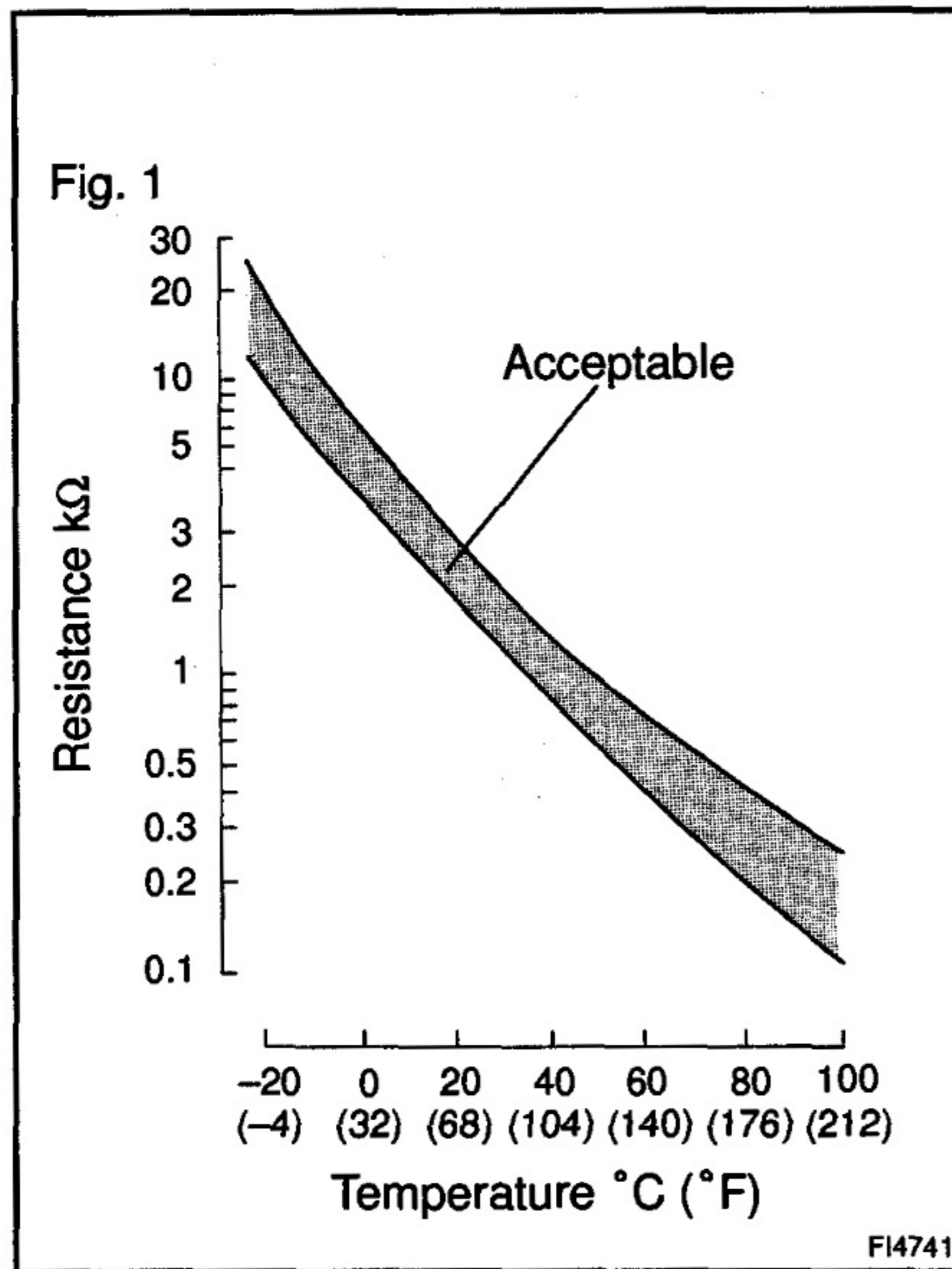

The fuel temperature sensor senses the fuel temperature. A thermistor built in the sensor changes the resistance value according to the fuel temperature. The lower the fuel temperature is, the greater the thermistor resistance value becomes, and the higher the fuel temperature, is the lower the thermistor resistance value (See Fig. 1) becomes.

The fuel temperature sensor is connected to the engine ECU (See below). The 5 V power source voltage in the engine ECU is applied to the fuel temperature sensor from terminal THF via a resistor R. That is, resistor R and the fuel temperature sensor are connected in series. When the resistance value of the fuel temperature sensor changes in accordance with changes in the fuel temperature, the potential at terminal THF also changes. Based on this signal, the engine ECU increases the fuel injection volume to improve driveability during low engine revolution and high fuel temperature.

DTC No.	DTC Detection Condition	Trouble Area
39	Open or short in fuel temperature sensor circuit for 0.5 seconds or more	<ul style="list-style-type: none"> • Open or short in fuel temp. sensor circuit • Fuel temp. sensor • Engine ECU

HINT:

After confirming DTC 39, use the hand-held tester to confirm the water temperature from the CURRENT DATA.

Displayed Temperature	Malfunction
-40°C (-40°F)	Open circuit
140°C (284°F) or more	Short circuit

WIRING DIAGRAM

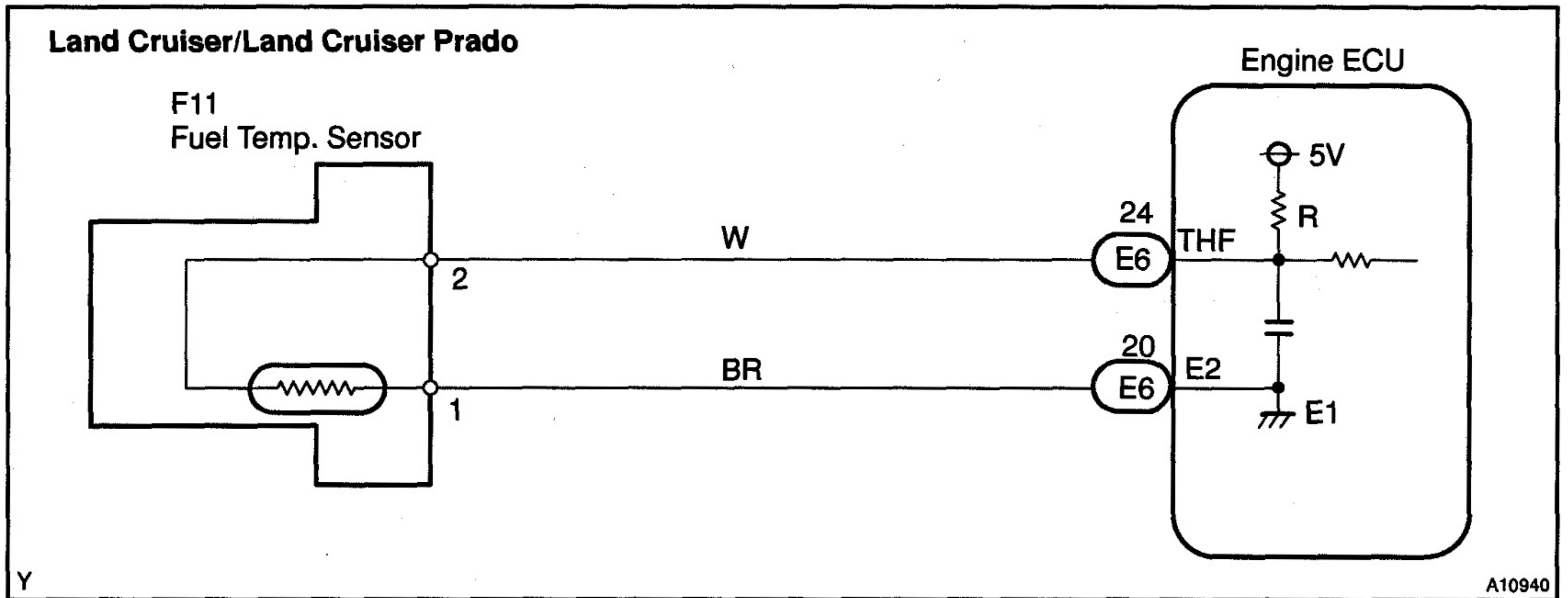
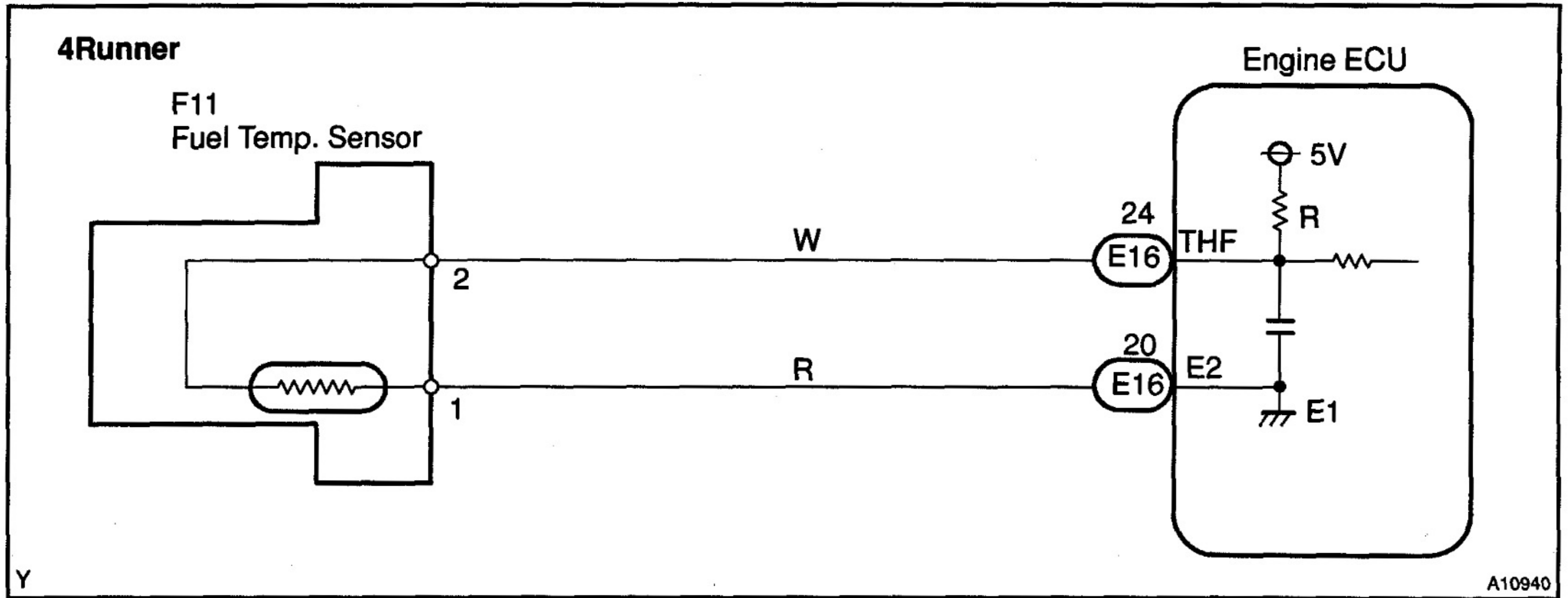
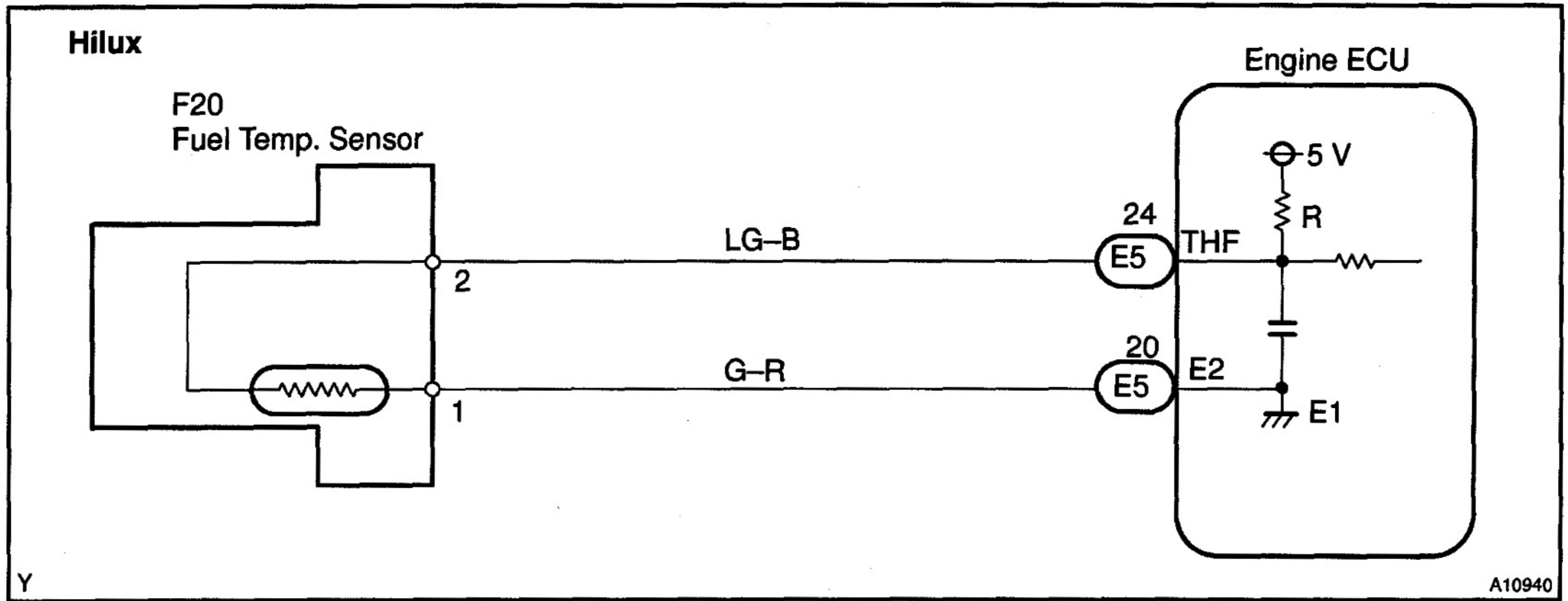

INSPECTION PROCEDURE

HINT:

- If DTC22, 24, 35 and 39 are output simultaneously, E2 (sensor ground) may be open.
- Read freeze frame data using hand-held tester, as freeze frame data records the engine conditions when a malfunction is detected. When troubleshooting, it is useful for determining whether the vehicle was running or stopped, the engine was warmed up or not, the air-fuel ratio was lean or rich, etc. at the time of the malfunction.

When using hand-held tester:

1	Connect hand-held tester, and read value of fuel temperature.
----------	--

PREPARATION:

- Connect the hand-held tester to the DLC3.
- Turn the ignition switch ON and push the hand-held tester main switch ON.

CHECK:

Read the temperature value on the hand-held tester.

OK:

Same value as the actual fuel temperature.

HINT:

- If there is open circuit, hand-held tester indicates -40°C (-40°F).
- If there is short circuit, hand-held tester indicates 140°C (284°F) or more.

NG

-40°C (-40°F) ... Go to step 2.
 140°C (284°F) or more ... Go to step 4.

OK

Check for intermittent problems (See page DI-4).

2	Check for open in harness or engine ECU.
----------	---

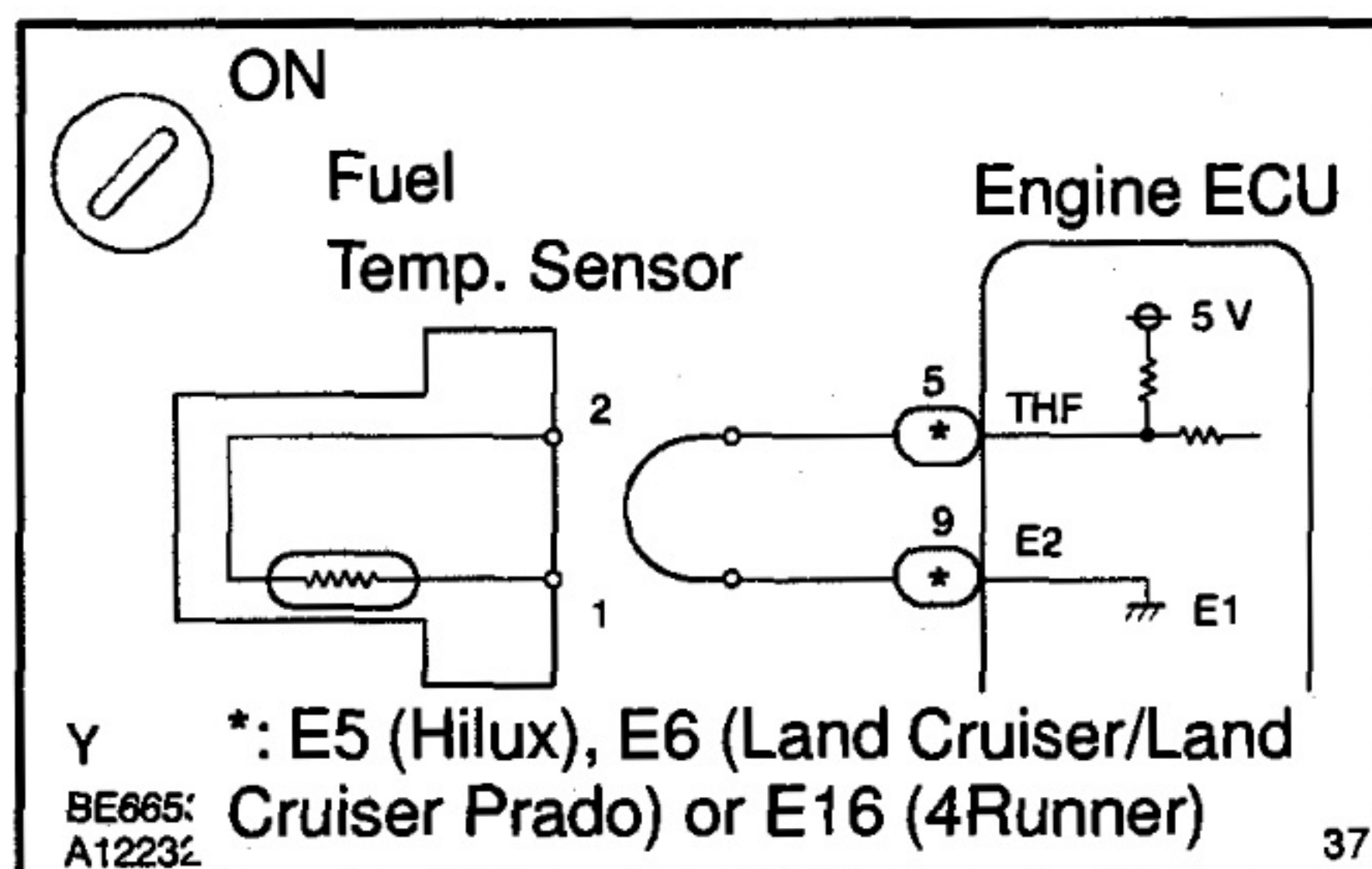

PREPARATION:

- Disconnect the fuel temperature sensor connector.
- Connect the sensor wire harness terminals together.
- Turn the ignition switch ON.

CHECK:

Read the temperature value on the hand-held tester.

OK:

Temperature value: 140°C (284°F) or more

OK

**Confirm good connection at sensor.
If OK, replace fuel temperature sensor.**

NG

3 Check for open in harness or engine ECU.

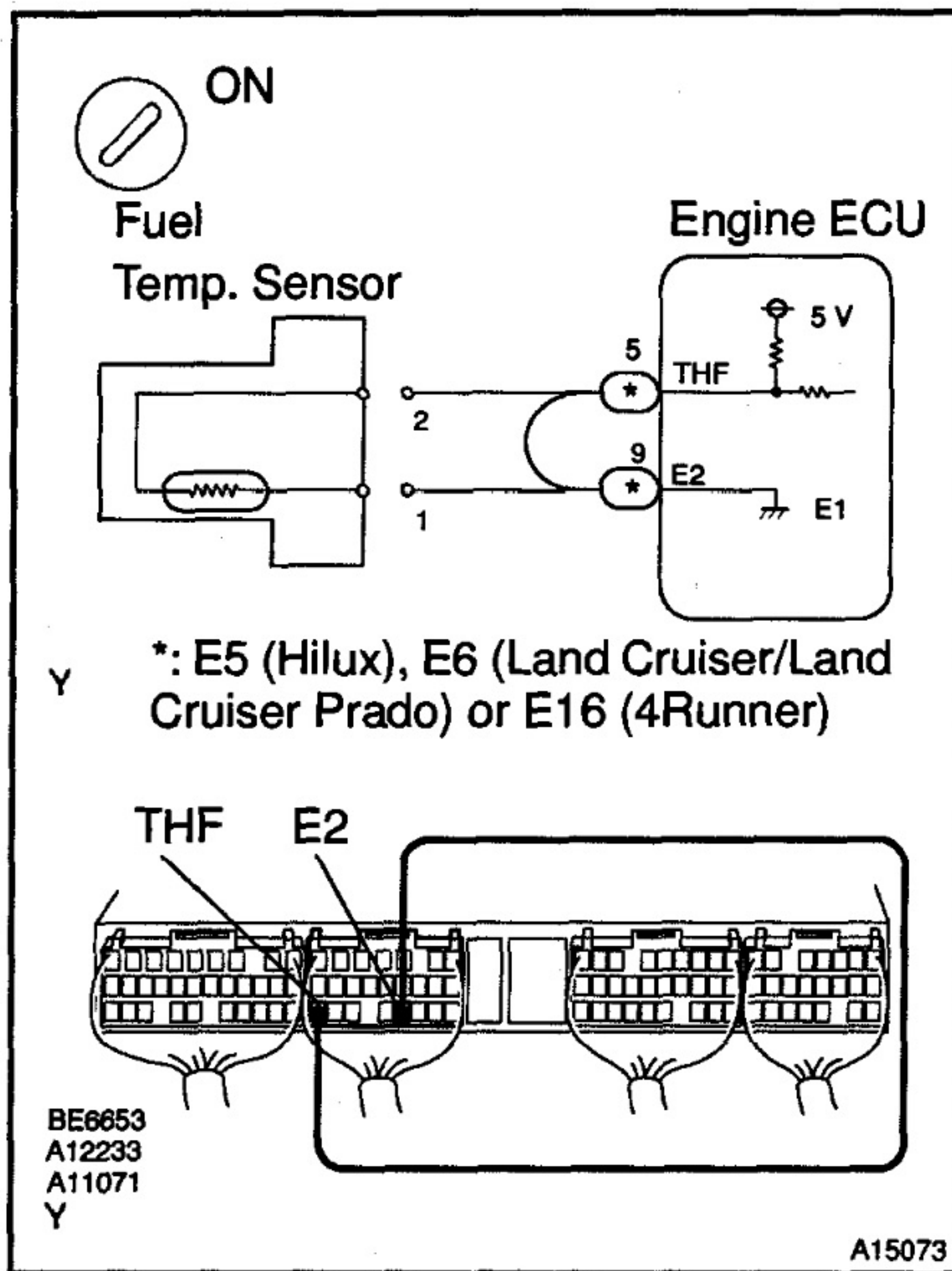

PREPARATION:

- Remove the glove compartment door.
- Connect terminals THF and E2 of the engine ECU connector.

HINT:

Fuel temperature sensor connector is disconnected. Before checking, do a visual and contact check of the pressure the engine ECU connector (See page IN-20).

- Turn the ignition switch ON.

CHECK:

Read the temperature value on the hand-held tester.

OK:

Temperature value: 140°C (284°F) or more

OK

Open in harness between terminal E2 or THF, repair or replace harness.

NG

Confirm good connection at engine ECU. If OK, replace engine ECU.

4 Check for short in harness or engine ECU.

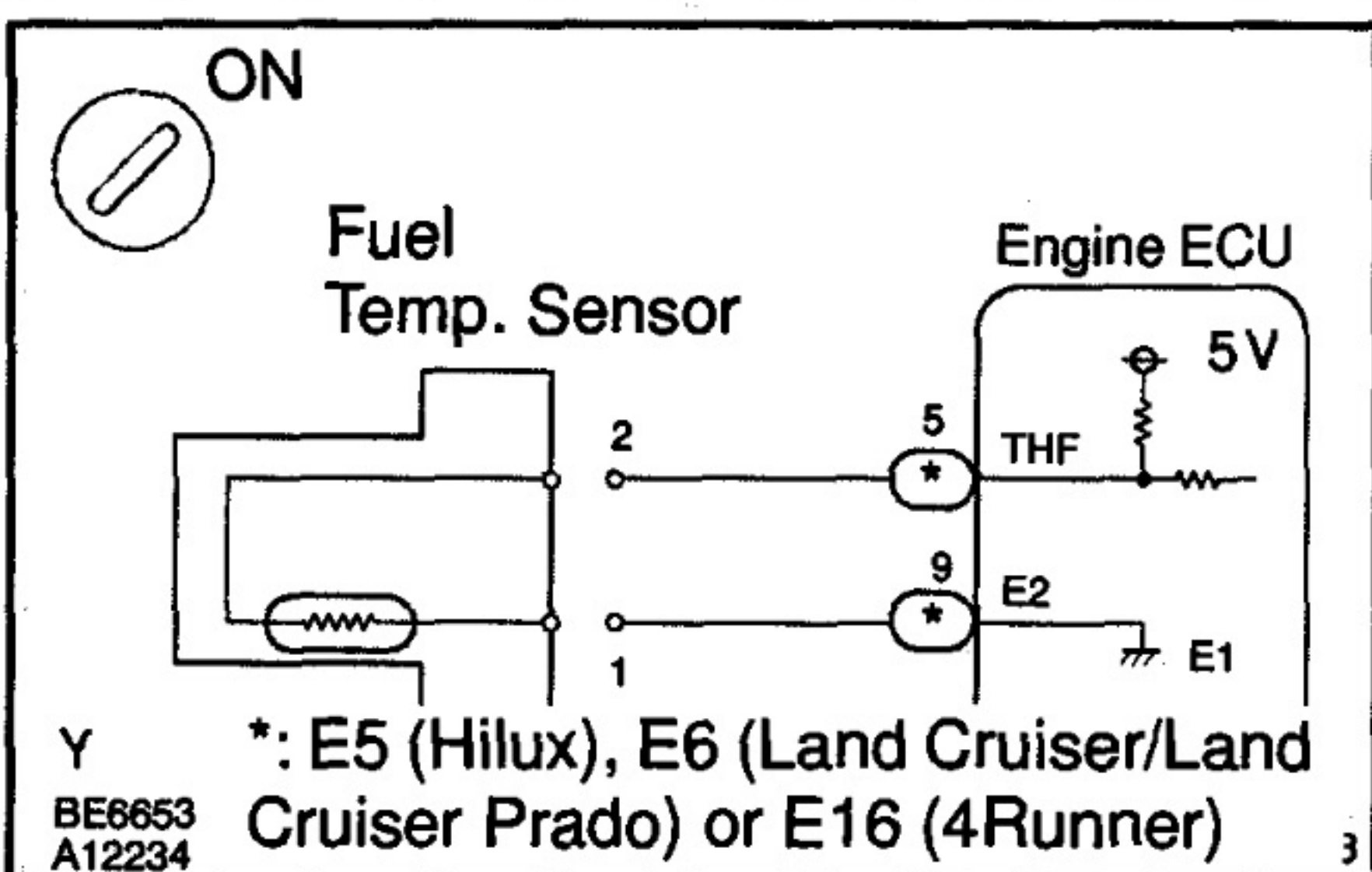

PREPARATION:

- Disconnect the fuel temperature sensor connector.
- Turn the ignition switch ON.

CHECK:

Read the temperature value on the hand-held tester.

OK:

Temperature value: -40°C (-40°F)

OK

Replace fuel temperature sensor.

NG

5 Check for short in harness or engine ECU.

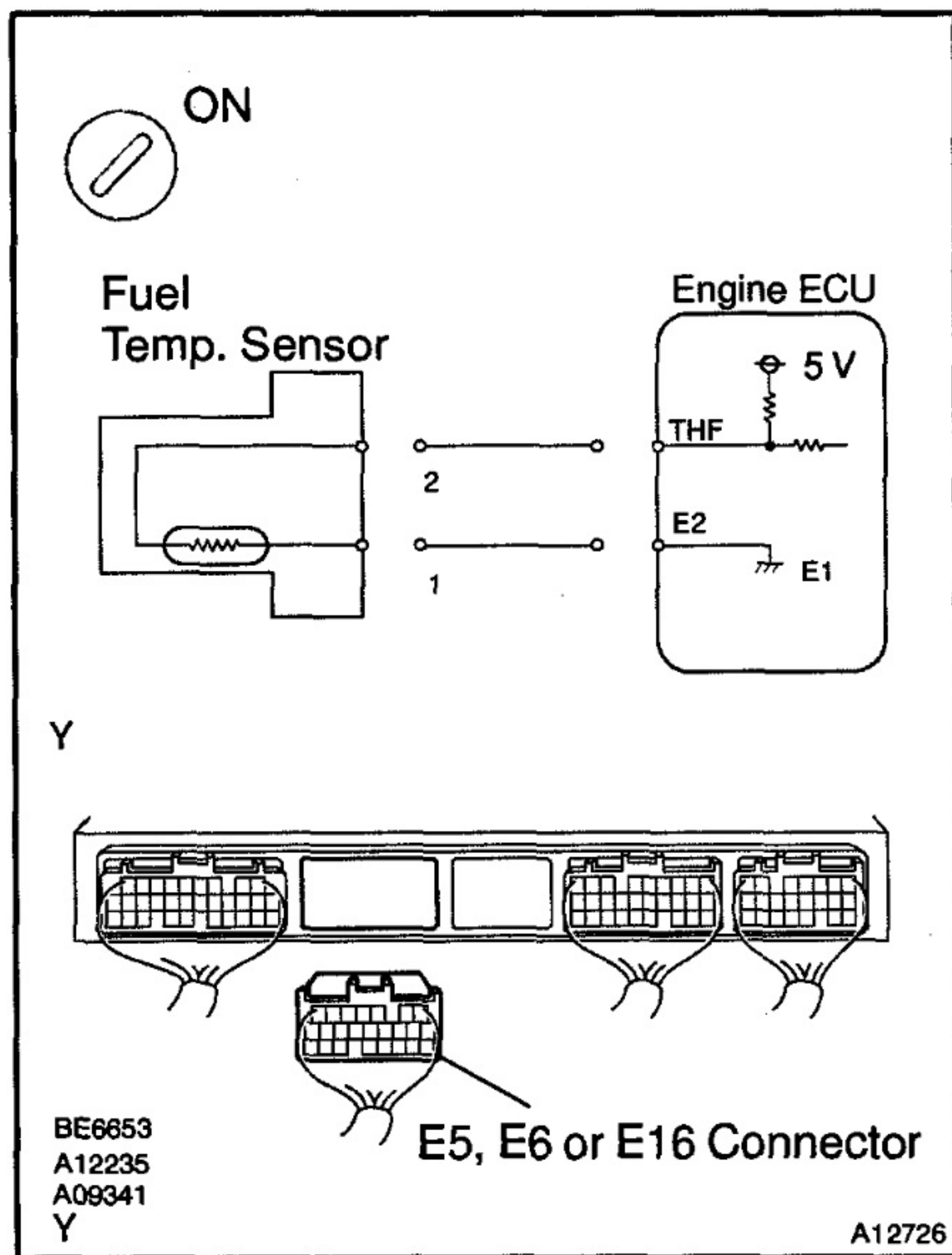

PREPARATION:

- (a) Remove the glove compartment door.
- (b) Disconnect the E5 (Hilux), E6 (Land Cruiser/Land Cruiser Prado) or E16 (4Runner) connector of the engine ECU.

HINT:

Fuel temperature sensor connector is disconnected.

- (c) Turn the ignition switch ON.

CHECK:

Read the temperature value on the hand-held tester.

OK:

Temperature value: -40°C (-40°F)

OK → Repair or replace harness or connector.

NG

Check and replace engine ECU (See page IN-20).

When not using hand-held tester:

1 Check voltage between terminals THF and E2 of engine ECU connector.

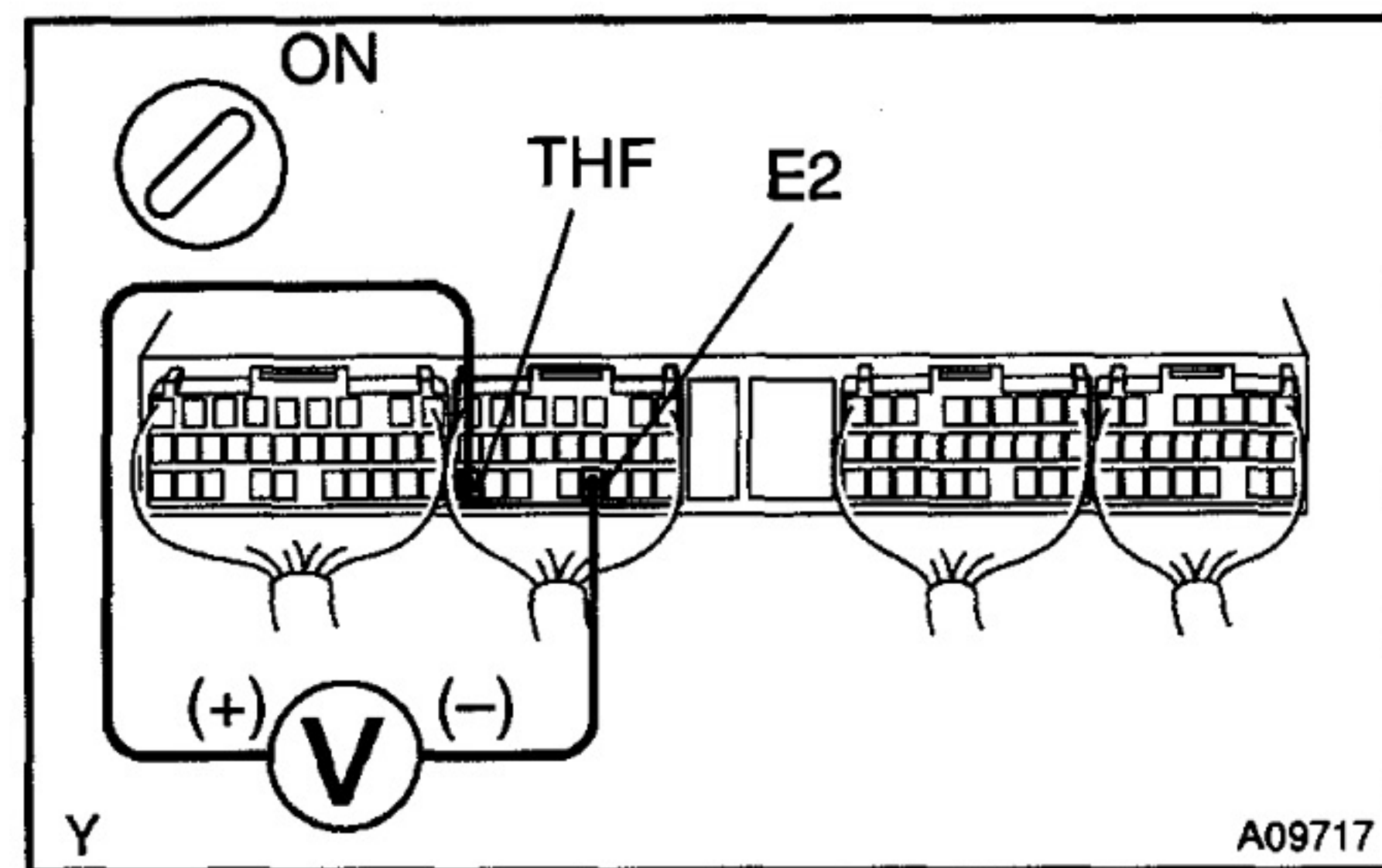

PREPARATION:

- (a) Remove the glove compartment door.
- (b) Turn the ignition switch ON.

CHECK:

Measure the voltage between terminals THF and E2 of the engine ECU connector.

OK:

Fuel Temp.	Voltage
70°C (68°F) (Engine is cool)	0.2 - 3.8 V
80°C (176°F) (Engine is hot)	0.1 - 1.5 V

OK → Check for intermittent problems (See page DI-4).

NG**2** Check fuel temperature sensor (See page ED-12).**NG**

Replace fuel temperature sensor.

OK**3** Check for open and short in harness and connector between engine ECU and fuel temperature sensor (See page IN-20).**NG**

Repair or replace harness or connector.

OK

Check and replace engine ECU.

DTC	42	Vehicle Speed Sensor Signal Circuit Malfunction
------------	-----------	--

CIRCUIT DESCRIPTION

The vehicle speed sensor outputs a 4-pulse signal for every revolution of the rotor shaft, which is rotated by the transmission output shaft via the driven gear. After this signal is converted into a more precise rectangular waveform by the waveform shaping circuit inside the combination meter, it is then transmitted to the engine ECU. The engine ECU determines the vehicle speed based on the frequency of these pulse signals.

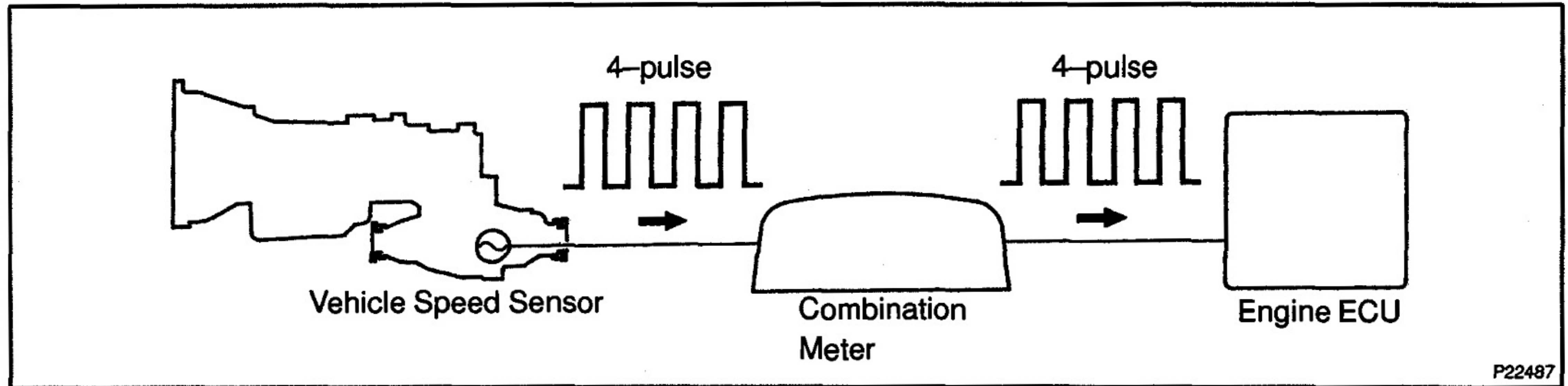

P22487

DTC No.	DTC Detection Condition	Trouble Area
42	<p>All conditions below are detected continuously for 8 sec. or more:</p> <ol style="list-style-type: none"> 1. Vehicle speed signal: 0 km/h (0 mph) 2. Engine speed: 2,400 ± 4,000 rpm 3. Engine coolant temp.: 60°C (176°F) or more 4. Accelerator pedal opening angle : 60 % or more 	<ul style="list-style-type: none"> • Combination meter • Open or short in vehicle speed sensor circuit • Vehicle speed sensor • Engine ECU

WIRING DIAGRAM

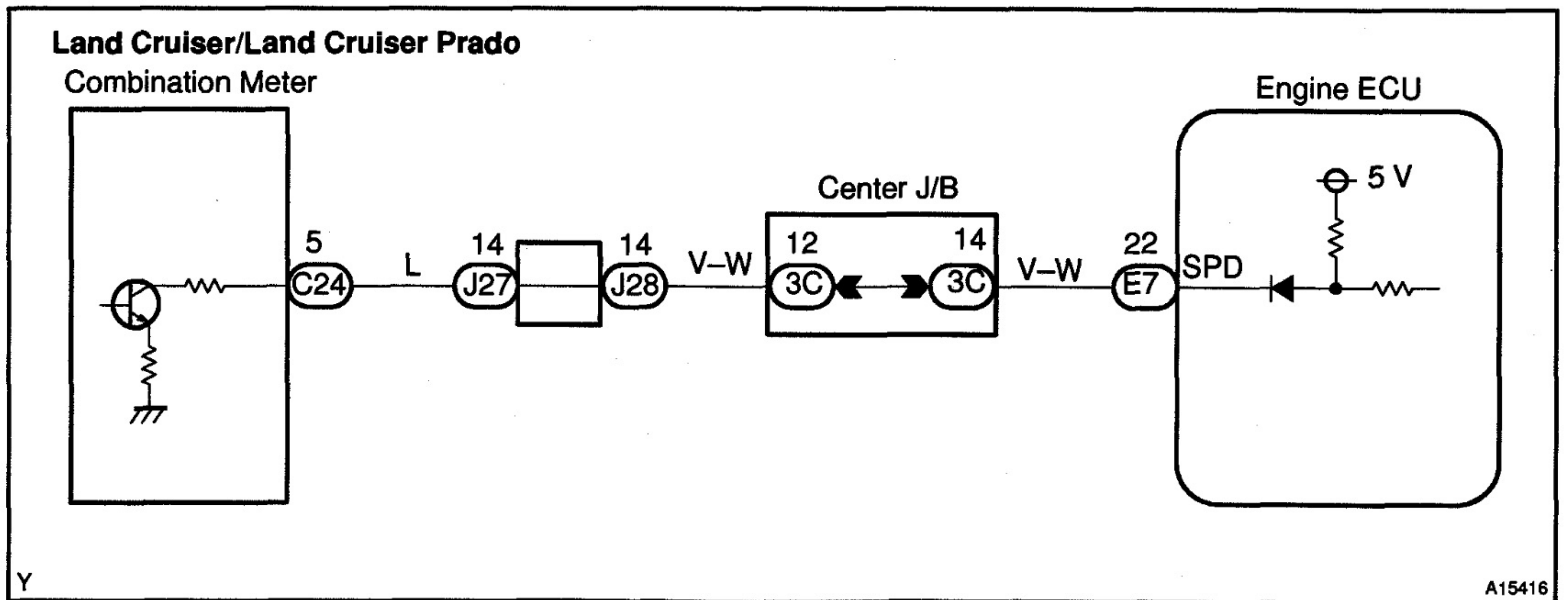
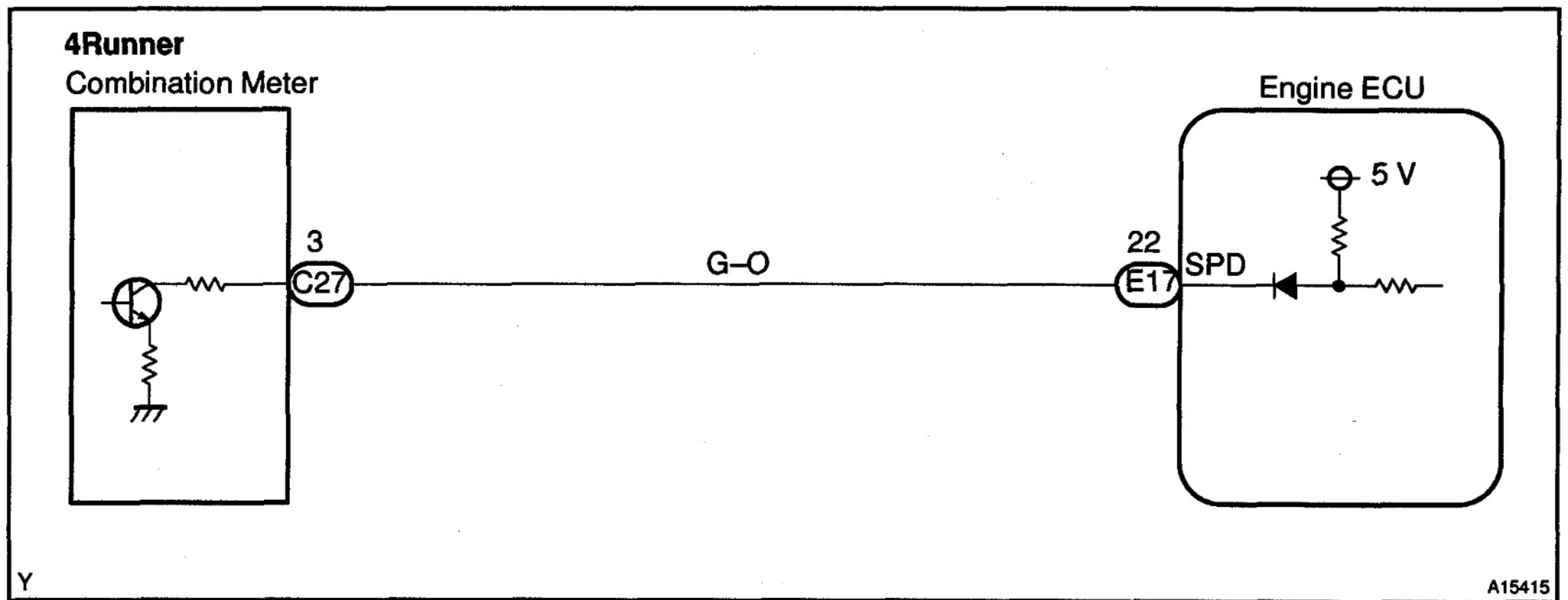
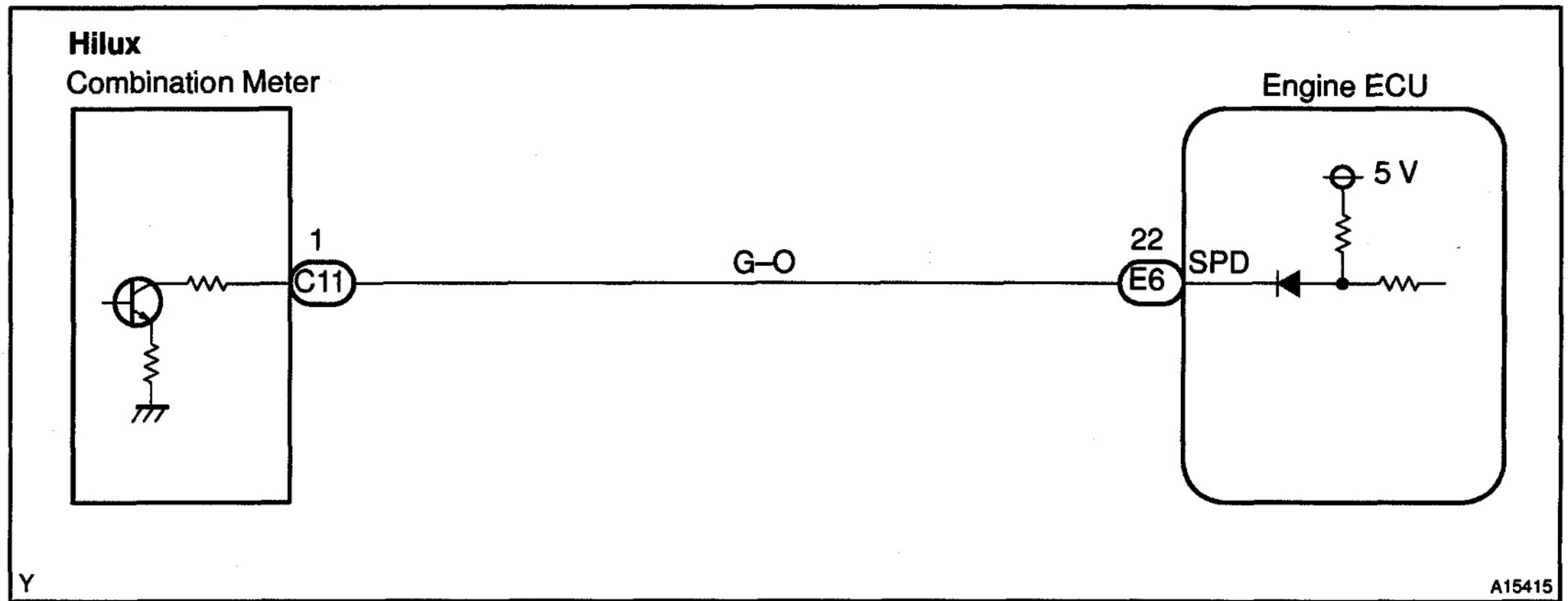

INSPECTION PROCEDURE

HINT:

Read freeze frame data using hand-held tester, as freeze frame data records the engine conditions when a malfunction is detected. When troubleshooting, it is useful for determining whether the vehicle was running or stopped, the engine was warmed up or not, the air-fuel ratio was lean or rich, etc. at the time of the malfunction.

1 Check operation of speedometer.

CHECK:

Drive the vehicle and check if the operation of the speedometer in the combination meter is normal.

HINT:

The vehicle speed sensor is operating normally if the speedometer display is normal.

NG

Check speedometer.

OK

2 Check voltage between terminal SP1 of engine ECU connector and body ground.

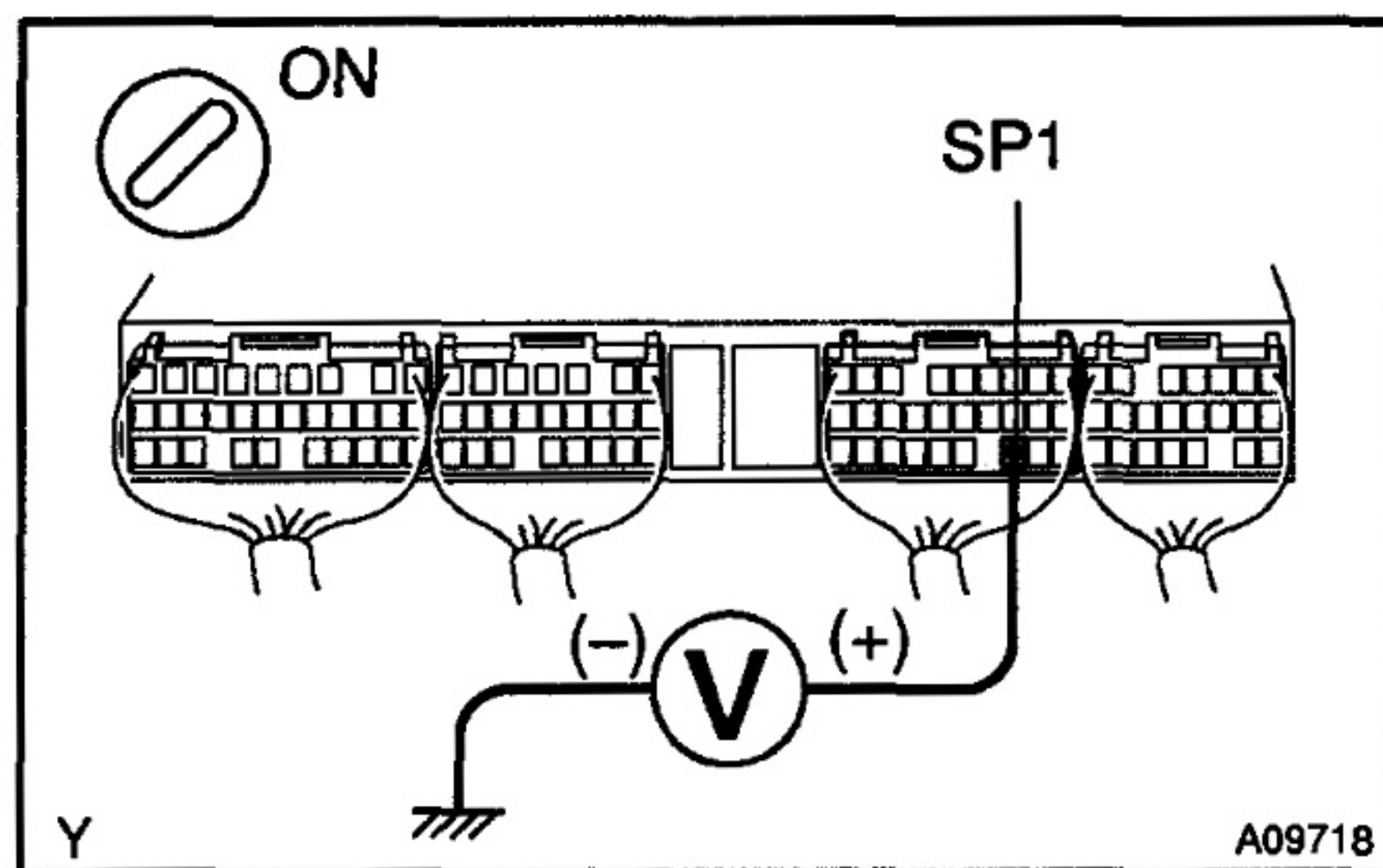

PREPARATION:

- Remove the glove compartment door.
- Shift the shift lever into neutral.
- Jack up one of the front wheels.
- Turn the ignition switch ON.

CHECK:

Measure the voltage between terminal SP1 of the engine ECU connector and the body ground when turning the wheel slowly.

OK:

Voltage is generated intermittently.

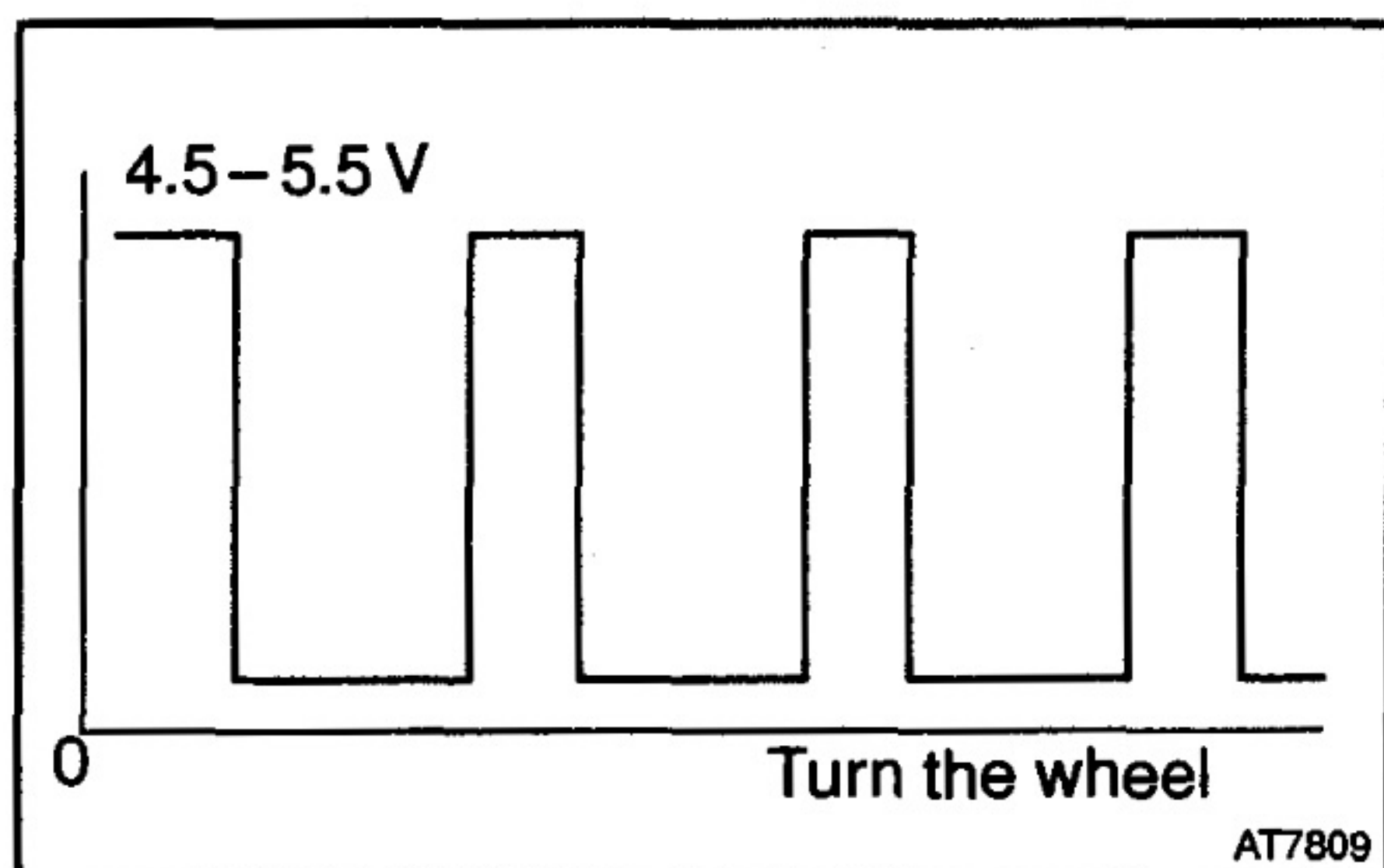

NG

Check and repair harness and connector between combination meter and engine ECU (See page IN-20).

OK

Check and replace engine ECU (See page IN-20).

DTC	96	EGR Valve Lift Sensor Circuit Malfunction
------------	-----------	--

CIRCUIT DESCRIPTION

DTC No.	DTC Detection Condition	Trouble Area
96	No EGLS signal to engine ECU for 1.0 sec. or more	<ul style="list-style-type: none"> • Open or short in EGR valve lift sensor circuit • EGR valve lift sensor • Engine ECU

WIRING DIAGRAM

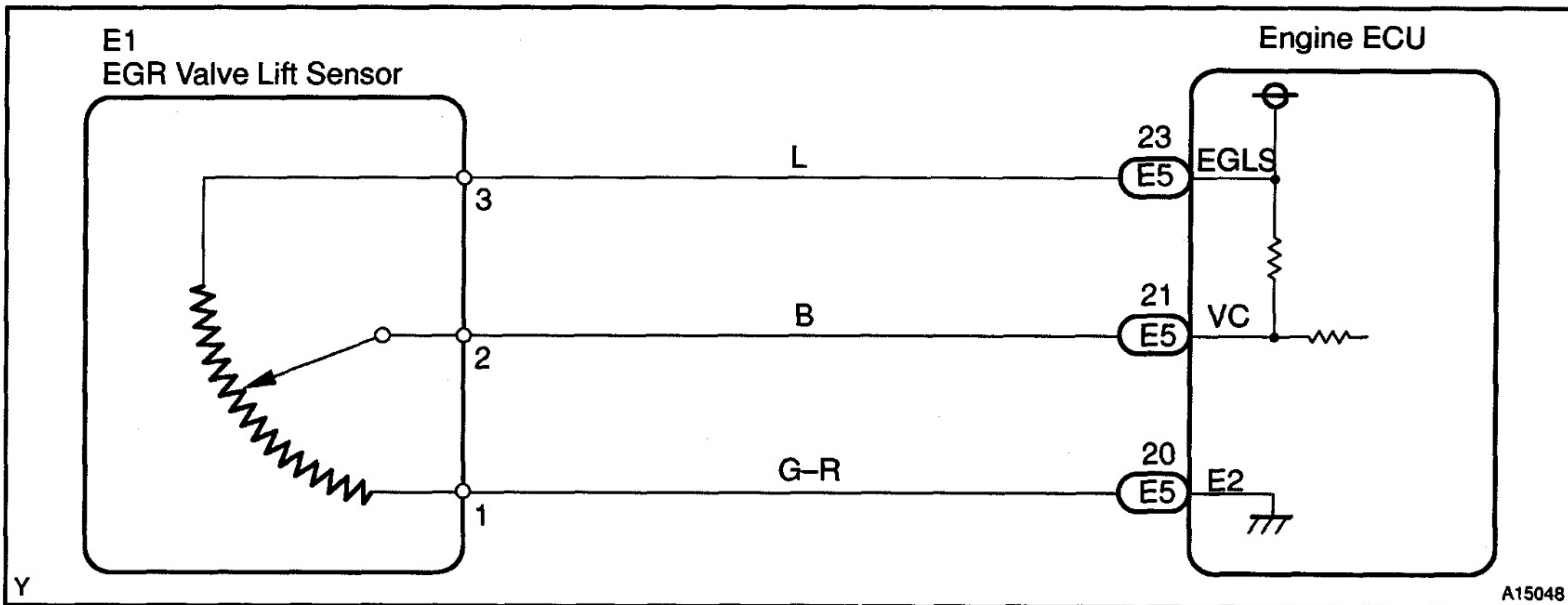

INSPECTION PROCEDURE

HINT:

Read freeze frame data using hand-held tester, as freeze frame data records the engine conditions when a malfunction is detected. When troubleshooting, it is useful for determining whether the vehicle was running or stopped, the engine was warmed up or not, the air-fuel ratio was lean or rich, etc. at the time of the malfunction.

1	Check EGR valve lift sensor (See page EC-6).
----------	---

NG
Replace EGR valve.

OK

- 2 Check voltage between terminal EGLS of engine ECU connector and body ground (See page EC-6).**

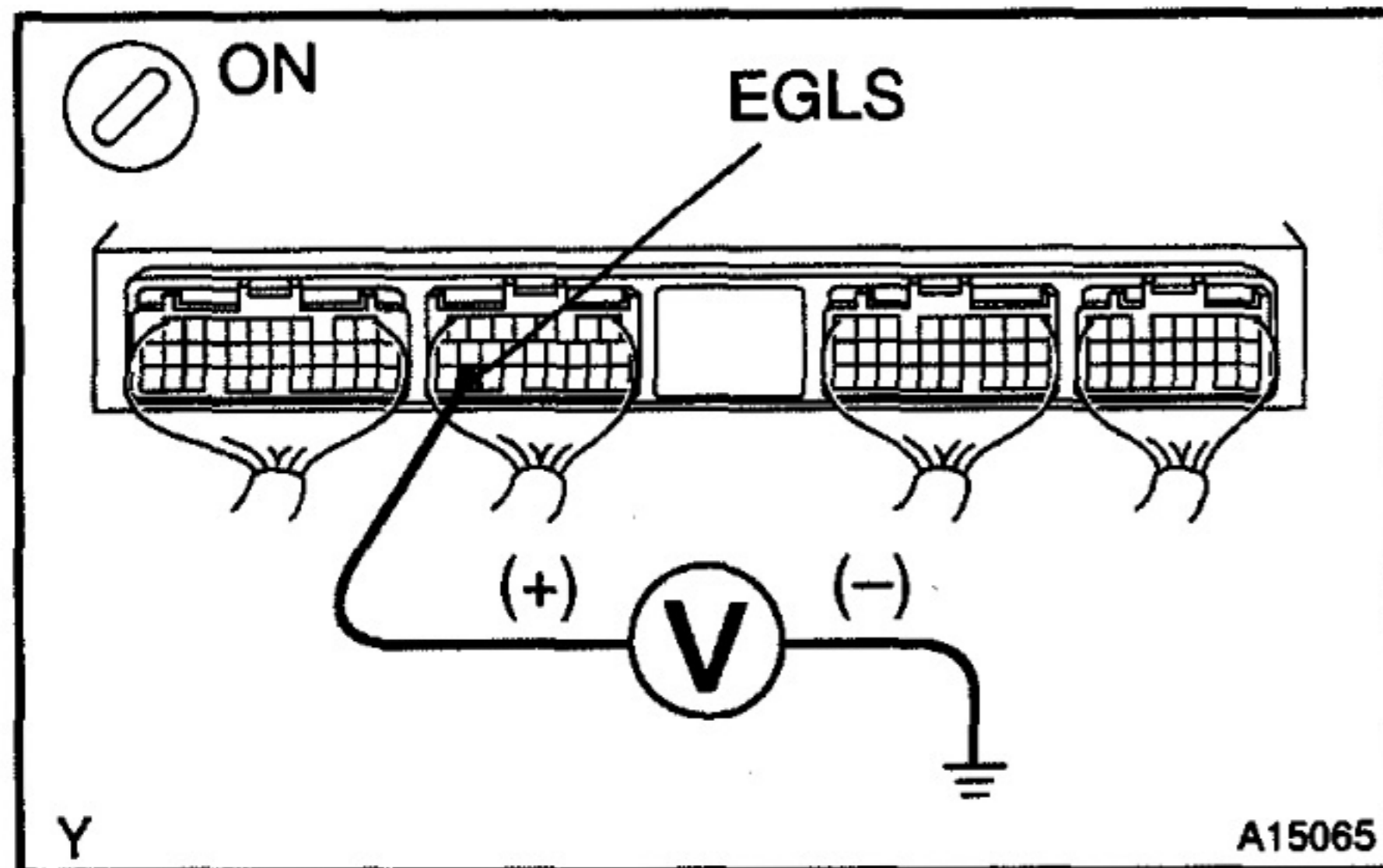
**PREPARATION:**

Remove the glove compartment door.

CHECK:

Check the voltage between terminal EGLS of the engine ECU connector and the body ground.

OK:

0.6 - 1.4 V

NG

Check and replace engine ECU (See page IN-20).

OK

- 3 Check for open and short in harness and connector between engine ECU and EGR valve lift sensor (See page IN-20).**

NG

Repair or replace harness or connector.

OK

- 4 Inspect sensor installation.**

NG

Tighten sensor.

OK

Check and replace engine ECU (See page IN-20).

Back Up Power Source Circuit

CIRCUIT DESCRIPTION

Battery positive voltage is applied to terminal +BF of the engine ECU even when the ignition switch is OFF for the use of the DTC memory, air-fuel ratio adaptive control value memory and etc.

WIRING DIAGRAM

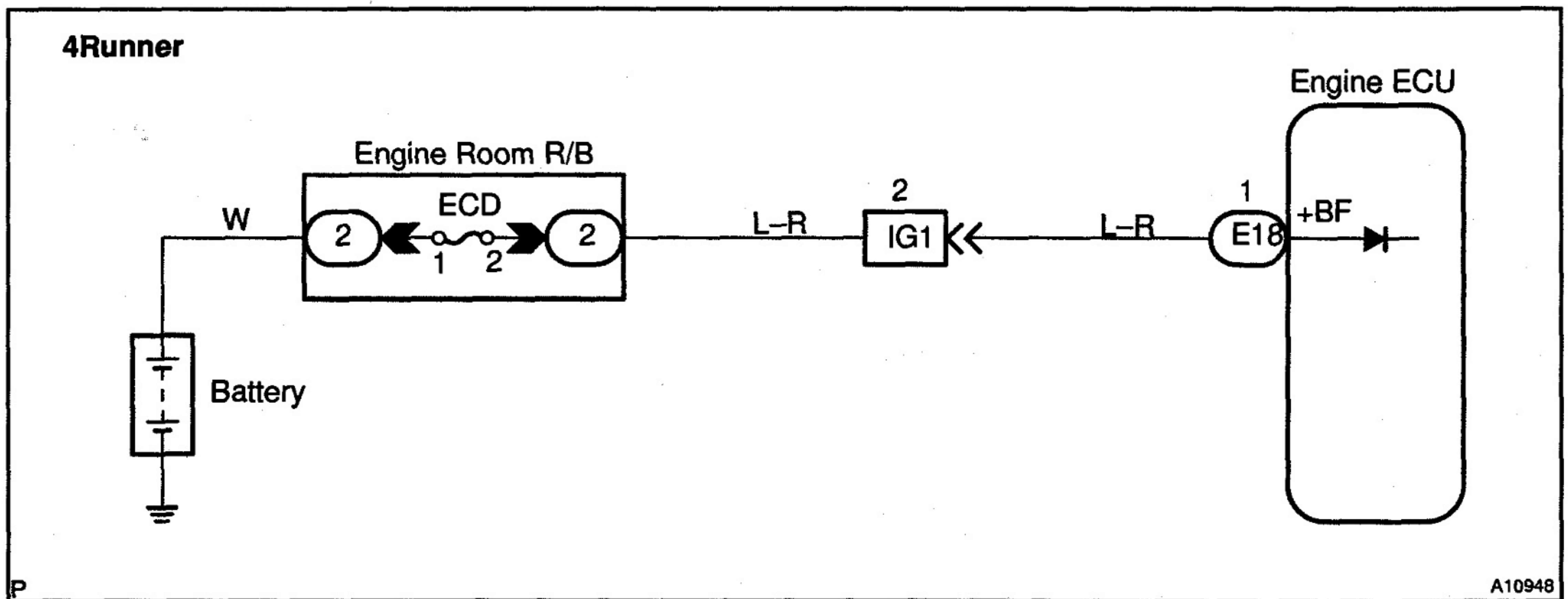
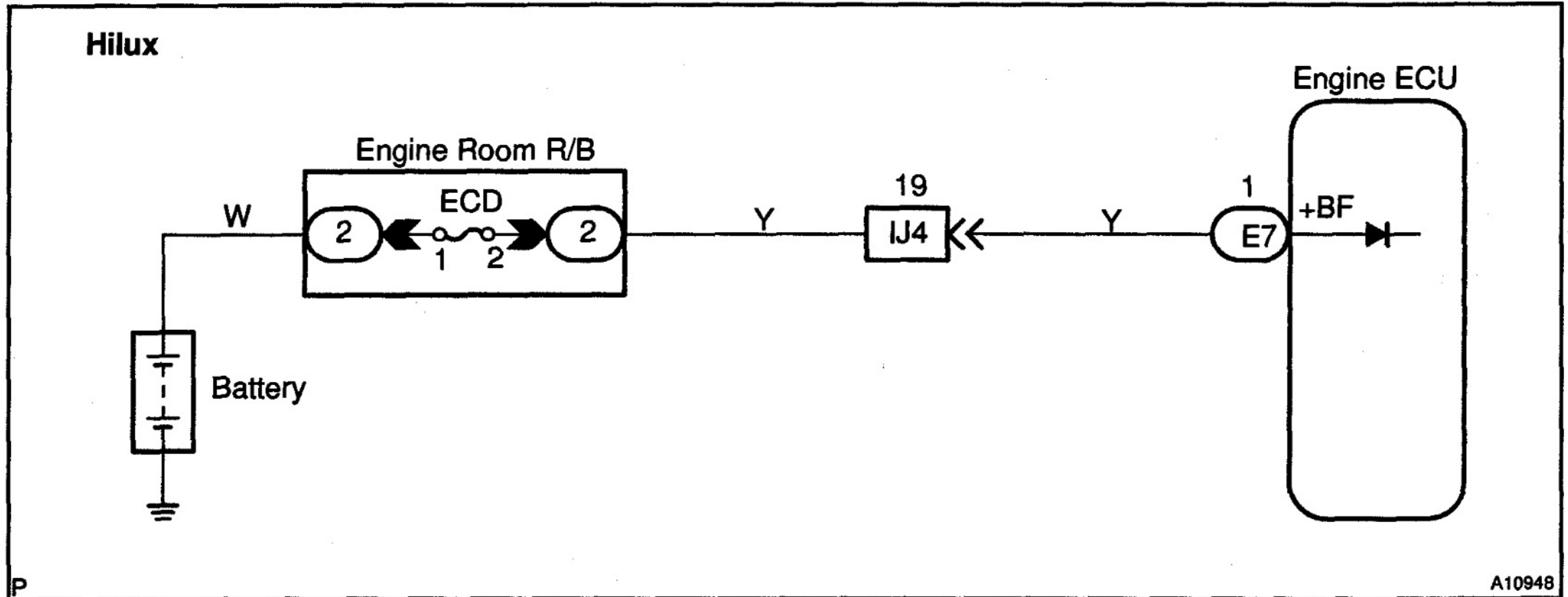

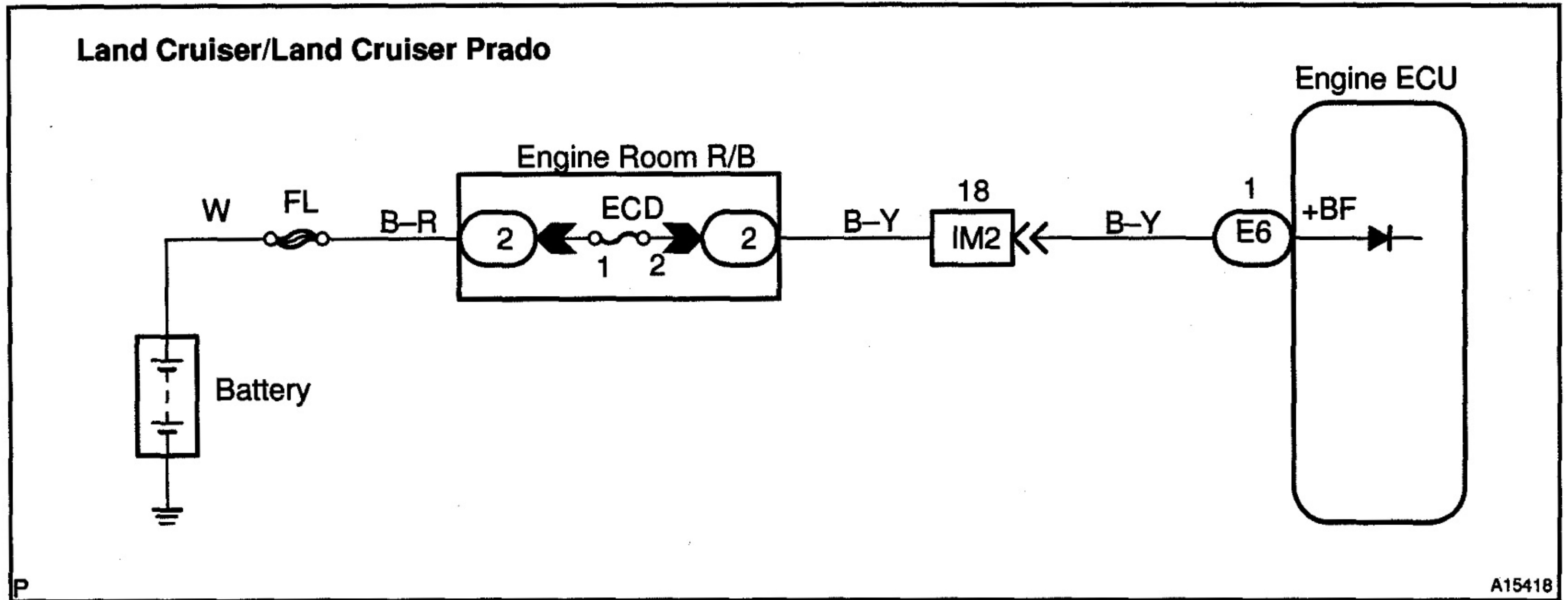

INSPECTION PROCEDURE

- | | |
|---|--|
| 1 | Check voltage between terminal +BF of engine ECU connector and body ground. |
|---|--|

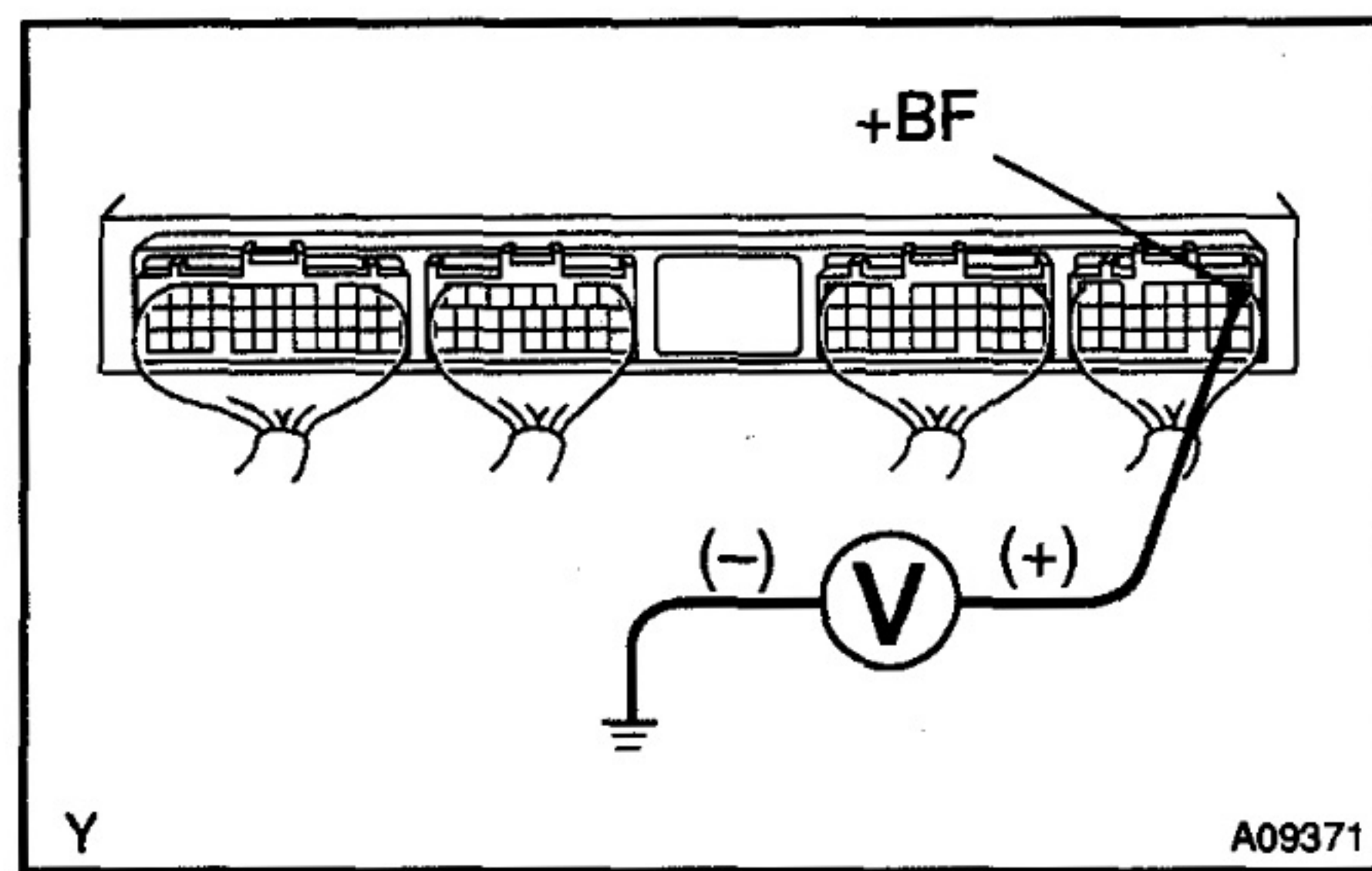

PREPARATION:

Remove the glove compartment.

CHECK:

Measure the voltage between terminal +BF of the engine ECU connector and the body ground.

OK:

Voltage: 9 - 14 V

OK

Check and replace engine ECU (See page IN-20).

NG

2 Check ECD fuse.

Hilux, 4Runner

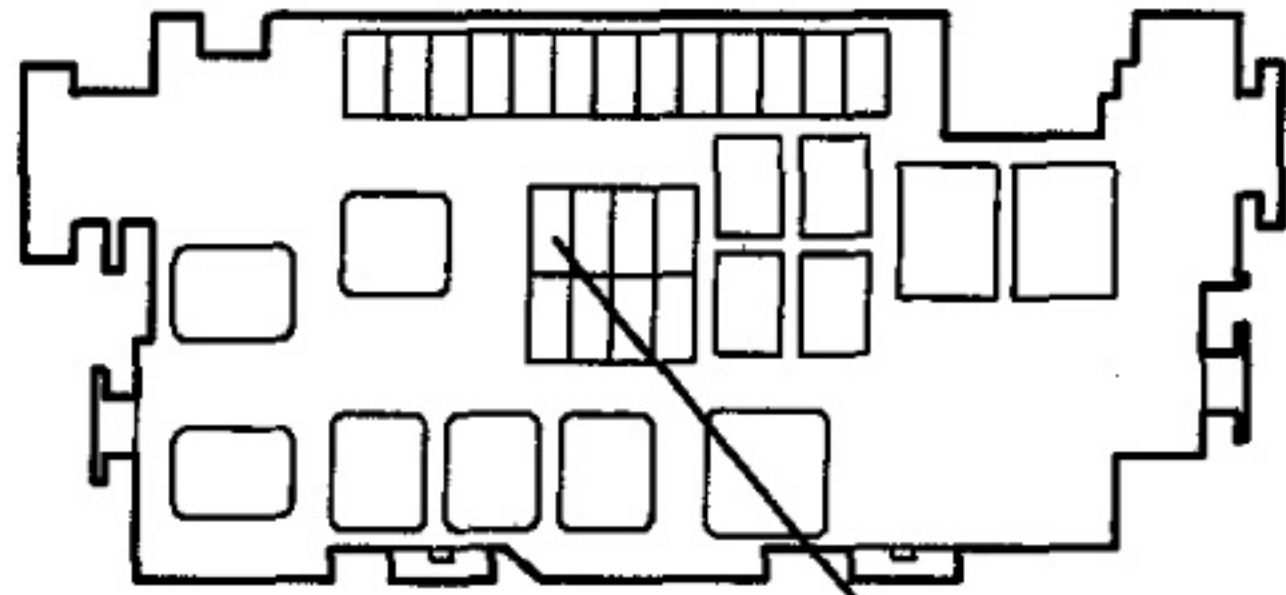

**Land Cruiser/
Land Cruiser Prado** ECD Fuse

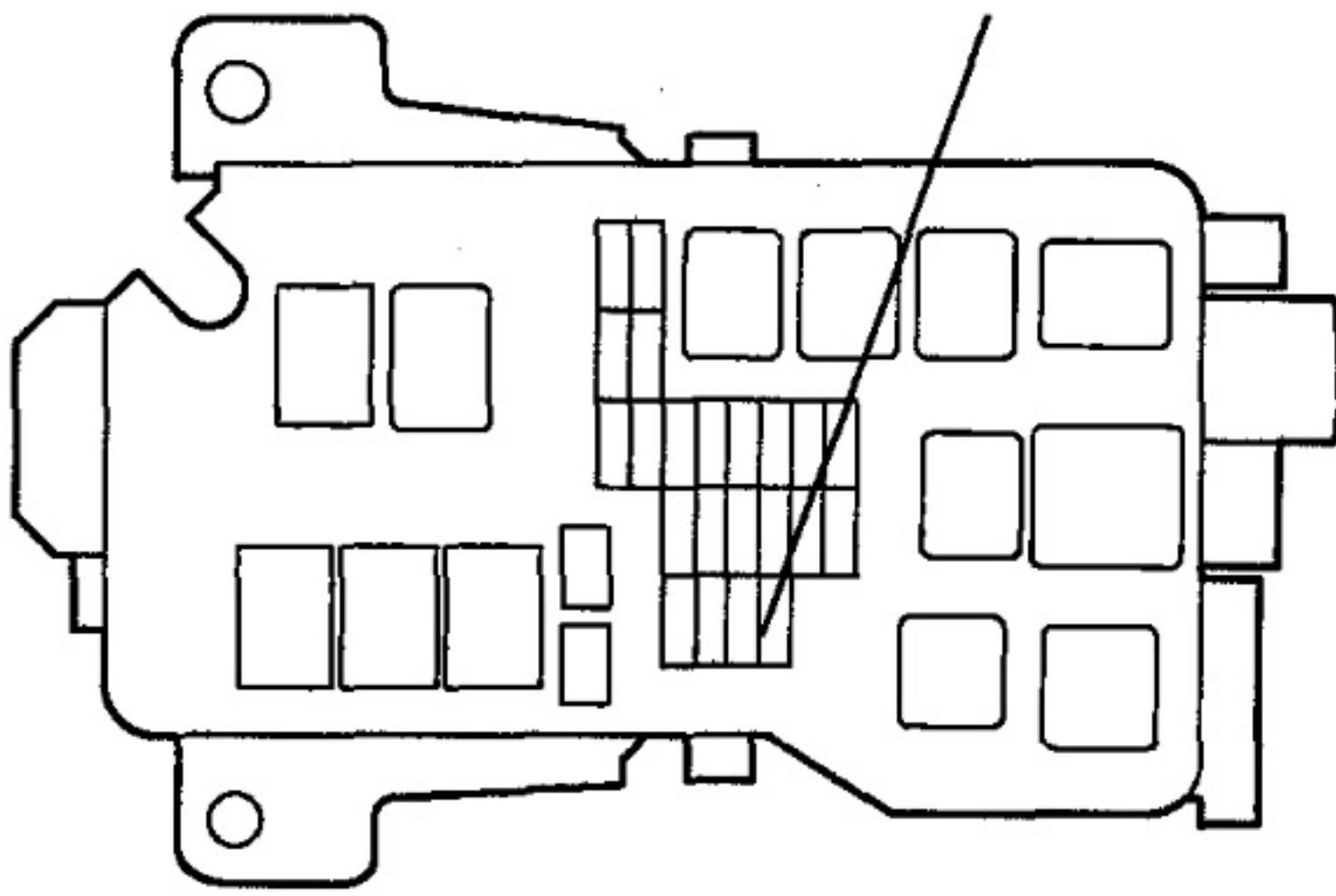

Y

A15376

PREPARATION:

Remove the ECD fuse from the engine room R/B.

CHECK:

Check the continuity of the ECD fuse.

OK:

Continuity

NG

Replace ECD fuse.

OK

Check and repair harness or connector between battery and ECD fuse, and ECD fuse and engine ECU (See page IN-20).

ECU Power Source Circuit

CIRCUIT DESCRIPTION

When the ignition switch is turned ON, battery positive voltage is applied to the coil, closing the contacts of the ECD main relay (Marking: ECD) and supplying power to the terminal +B of the engine ECU.

WIRING DIAGRAM

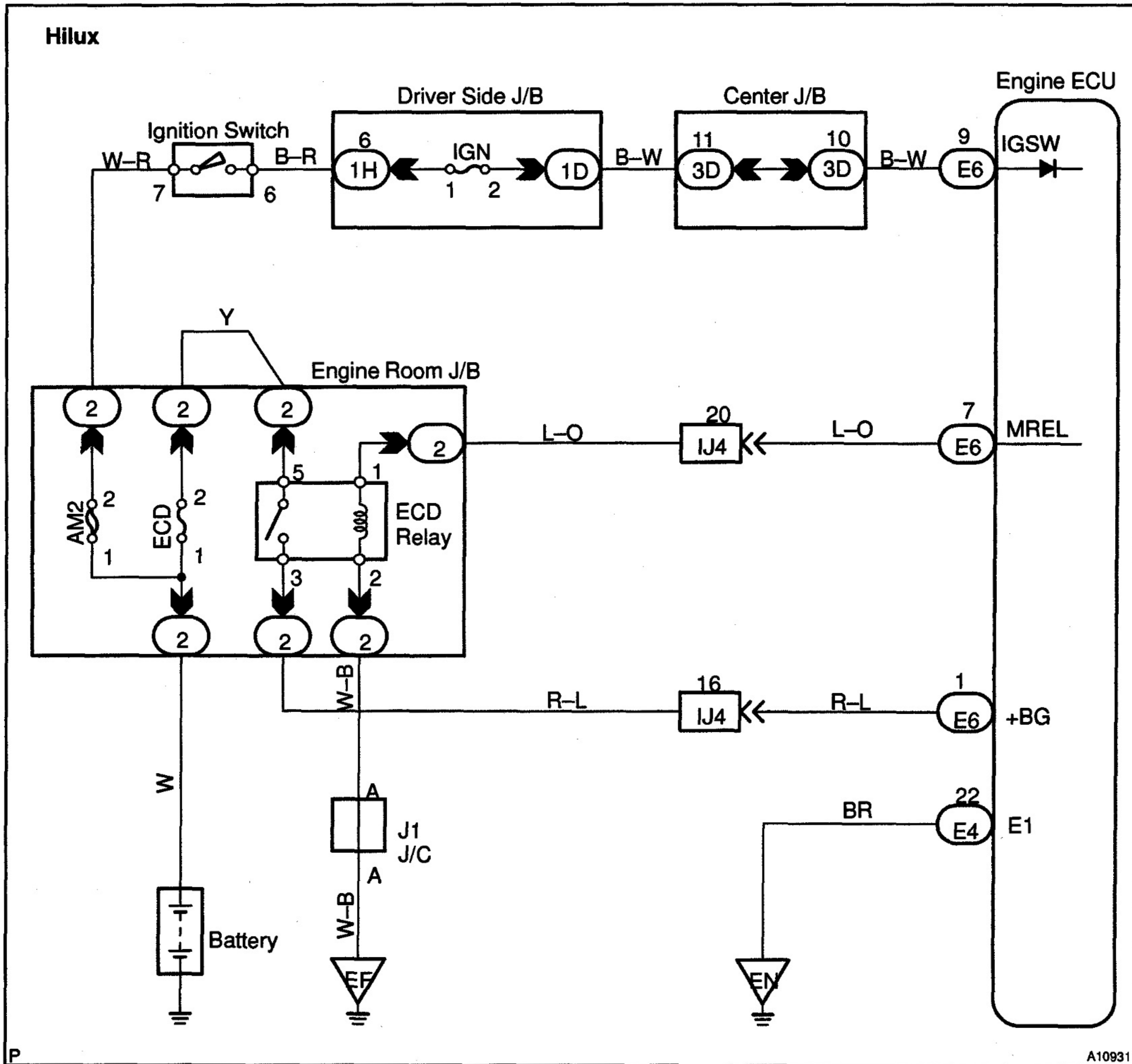

4Runner

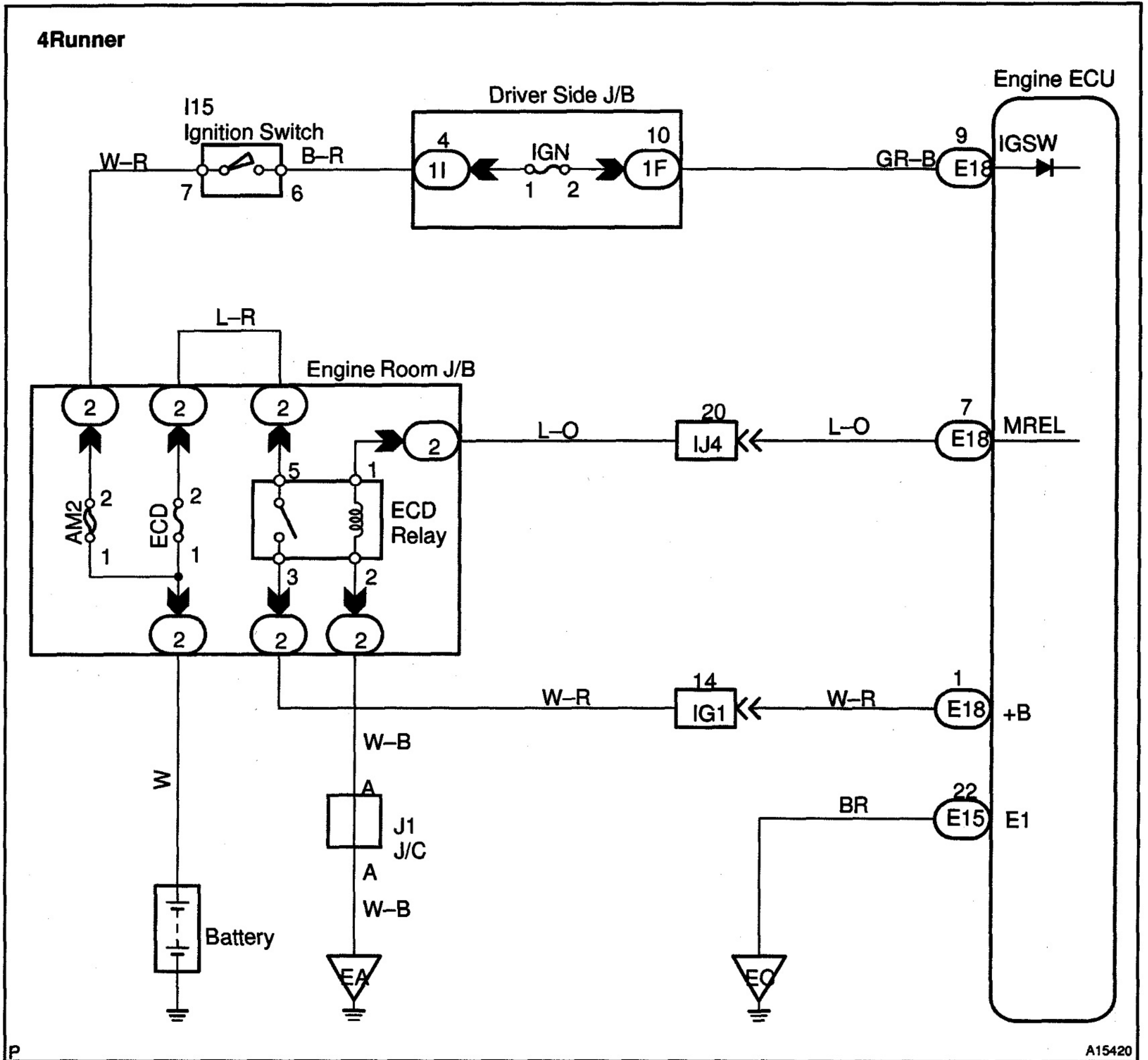

P

A15420

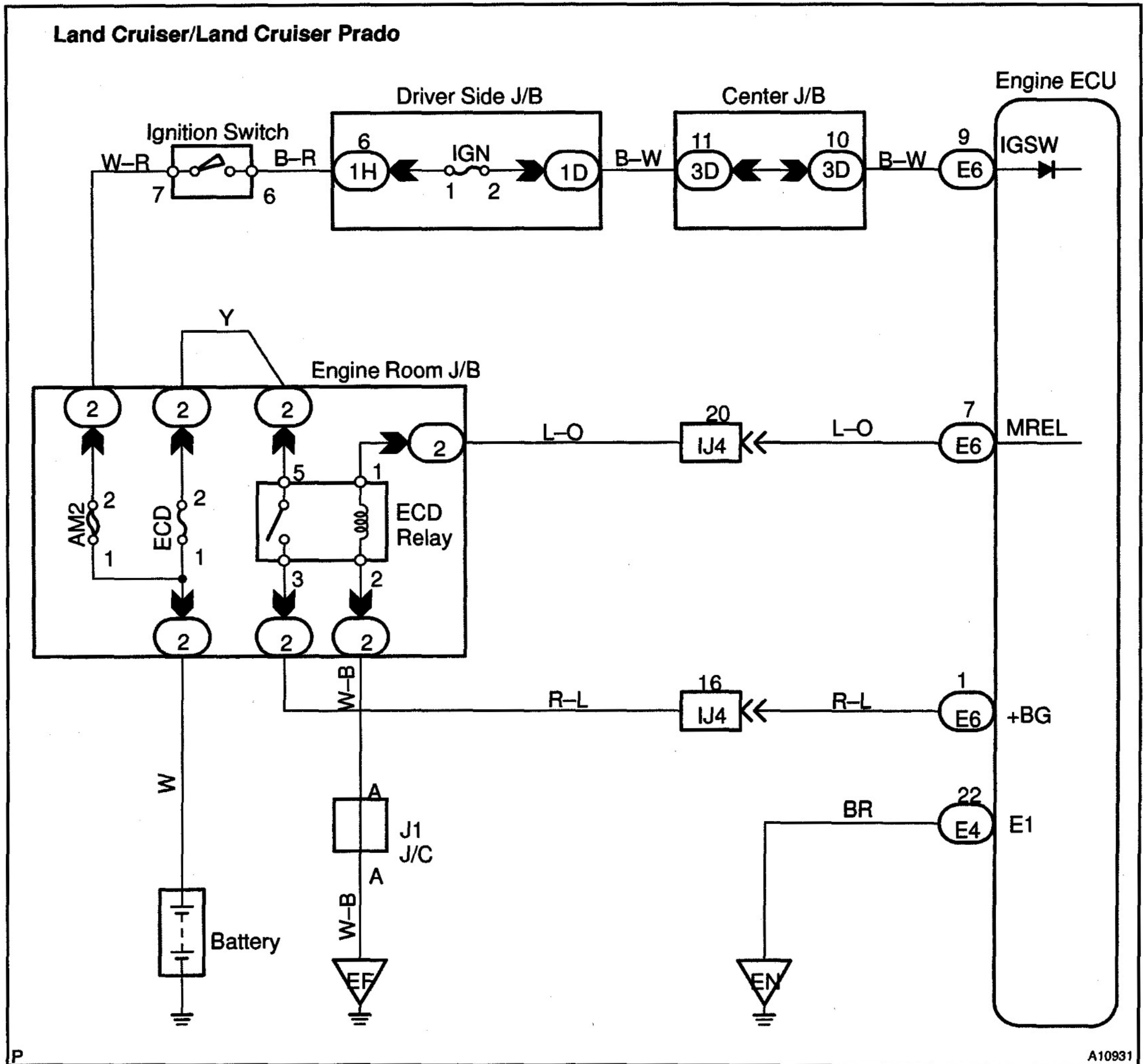

INSPECTION PROCEDURE

1	Check voltage between terminals +B and E1 of engine ECU connector.
----------	---

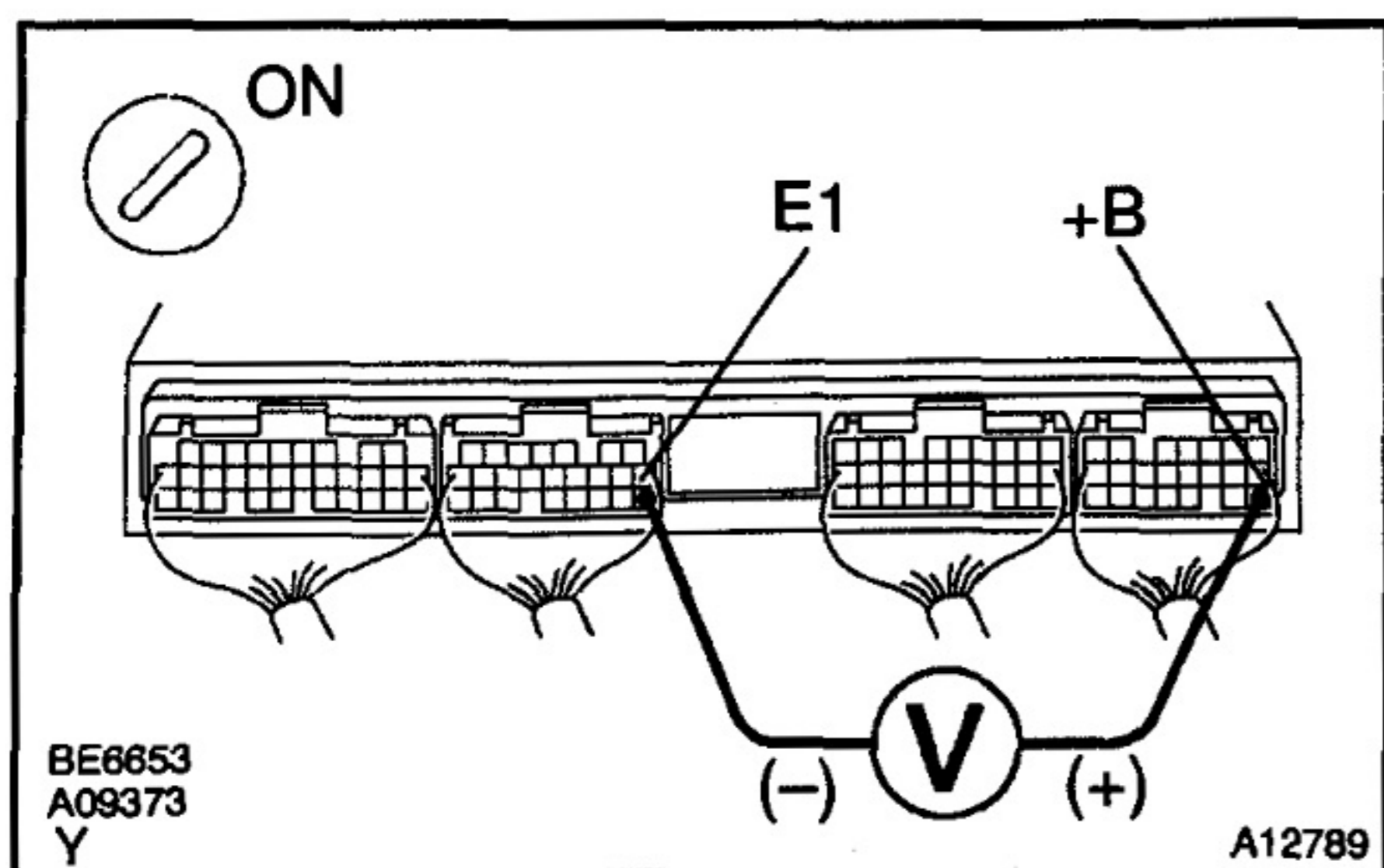

PREPARATION:

- (a) Remove the glove compartment door.
- (b) Turn the ignition switch ON.

CHECK:

Measure the voltage between terminals +B and E1 of the engine ECU connector.

OK:

Voltage: 9 - 14 V

OK

Proceed to next circuit inspection shown on problem symptoms table (See page DI-24).

NG

2

Check for open in harness and connector between terminal E1 of engine ECU and body ground (See page IN-20).

NG

Repair or replace harness or connector.

OK

3

Check ECD main relay (Marking: ECD) (See Pub. No. RM710E, ED section).

NG

Replace ECD main relay.

OK

4

Check ECD fuse (See page DI-89).

NG

Replace ECD fuse.

OK

5

Check for open in harness and connector between engine ECU and ECD main relay (Marking: ECD) and ECD main relay and battery (See page IN-20).

NG

Repair or replace harness or connector.

OK

6 Check voltage between terminal IGSW of engine ECU connector and body ground.

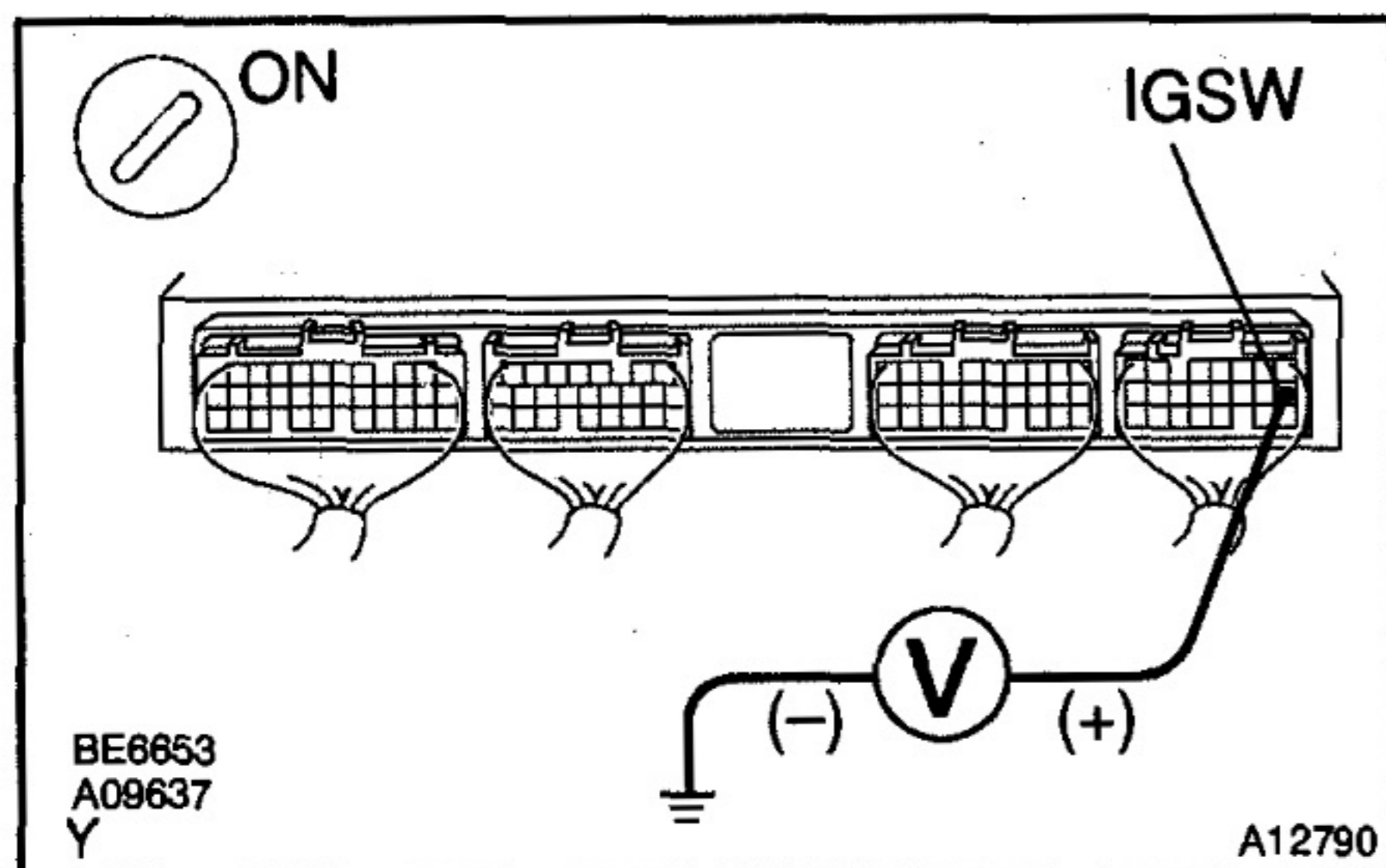
**PREPARATION:**

- (a) Remove the glove compartment door.
- (b) Turn the ignition switch ON.

CHECK:

Measure the voltage between terminal IGSW of the engine ECU connector and the body ground.

OK:

Voltage: 9 - 14 V

OK

Go to step 9.

NG

7 Check ignition switch (See Pub. No. RM789E (Hilux), RM805E (Land Cruiser/Land Cruiser Prado) or RM663U (4Runner) BE section).

NG

Replace ignition switch.

OK

8 Check for open in harness and connector between ignition switch and engine ECU (See page IN-20).

NG

Repair or replace harness or connector.

OK

9 Check voltage between terminal MREL of engine ECU connector and body ground.

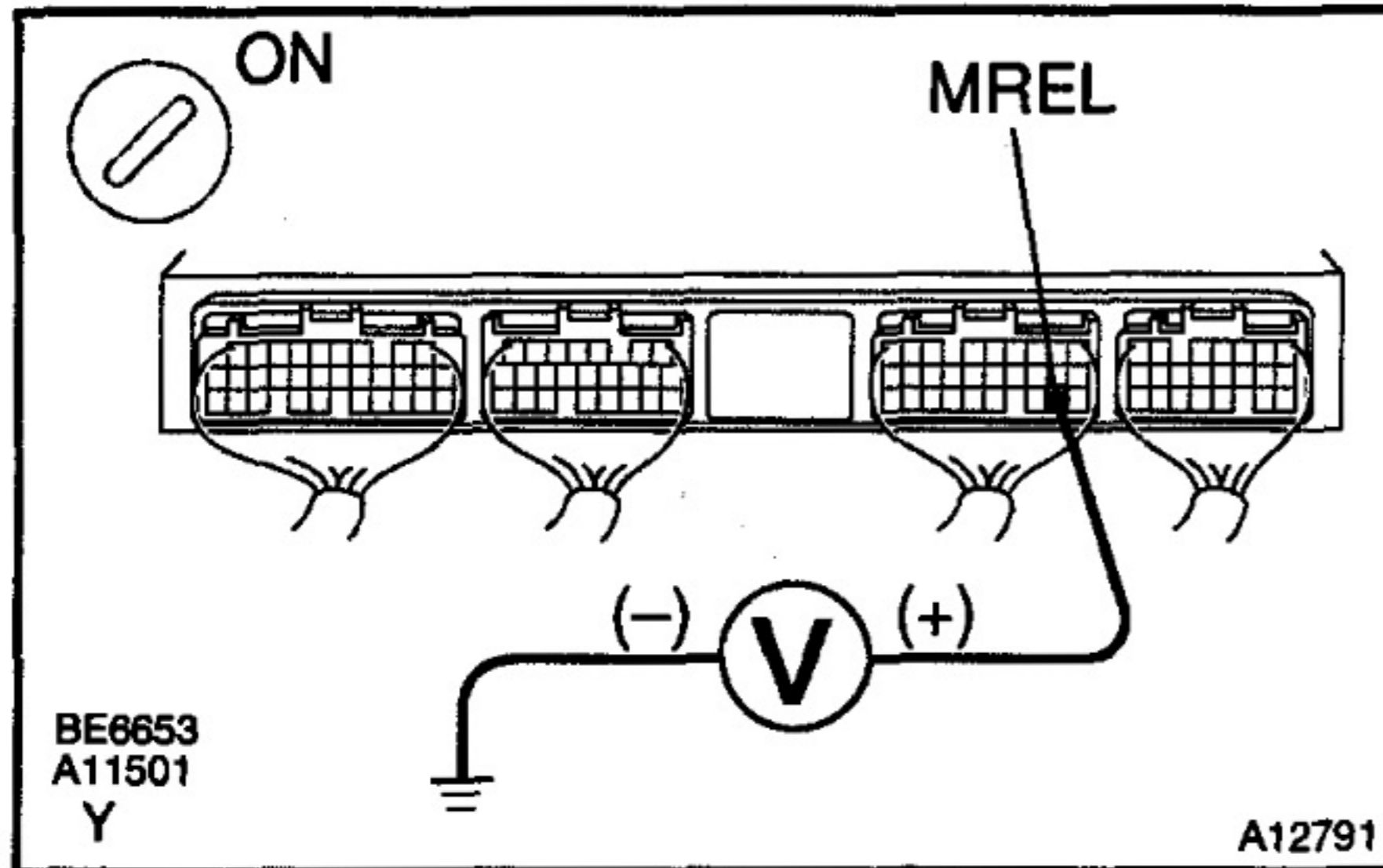

PREPARATION:

- (a) Remove the glove compartment door.
- (b) Turn the ignition switch ON.

CHECK:

Measure the voltage between terminal MREL of the engine ECU connector and the body ground.

OK:

Voltage: 9 – 14 V

OK

Check and replace engine ECU (See page IN-20).

NG

Check for open in harness and connector between engine ECU and ECD main relay (Marking: ECD), and ECD main relay and body ground (See page IN-20).

Diagnostic Connector (DLC3) Circuit

CIRCUIT DESCRIPTION

Terminals TC and CG are located in the DLC3.

The DLC3 is located under the finish lower panel. When terminals TC and CG are connected, a DTC in the normal mode or test mode can be read from the check engine warning light in the combination meter.

Also, terminal SIL is located in the DLC3. This terminal is used for the M-OBD communication with hand-held tester.

WIRING DIAGRAM

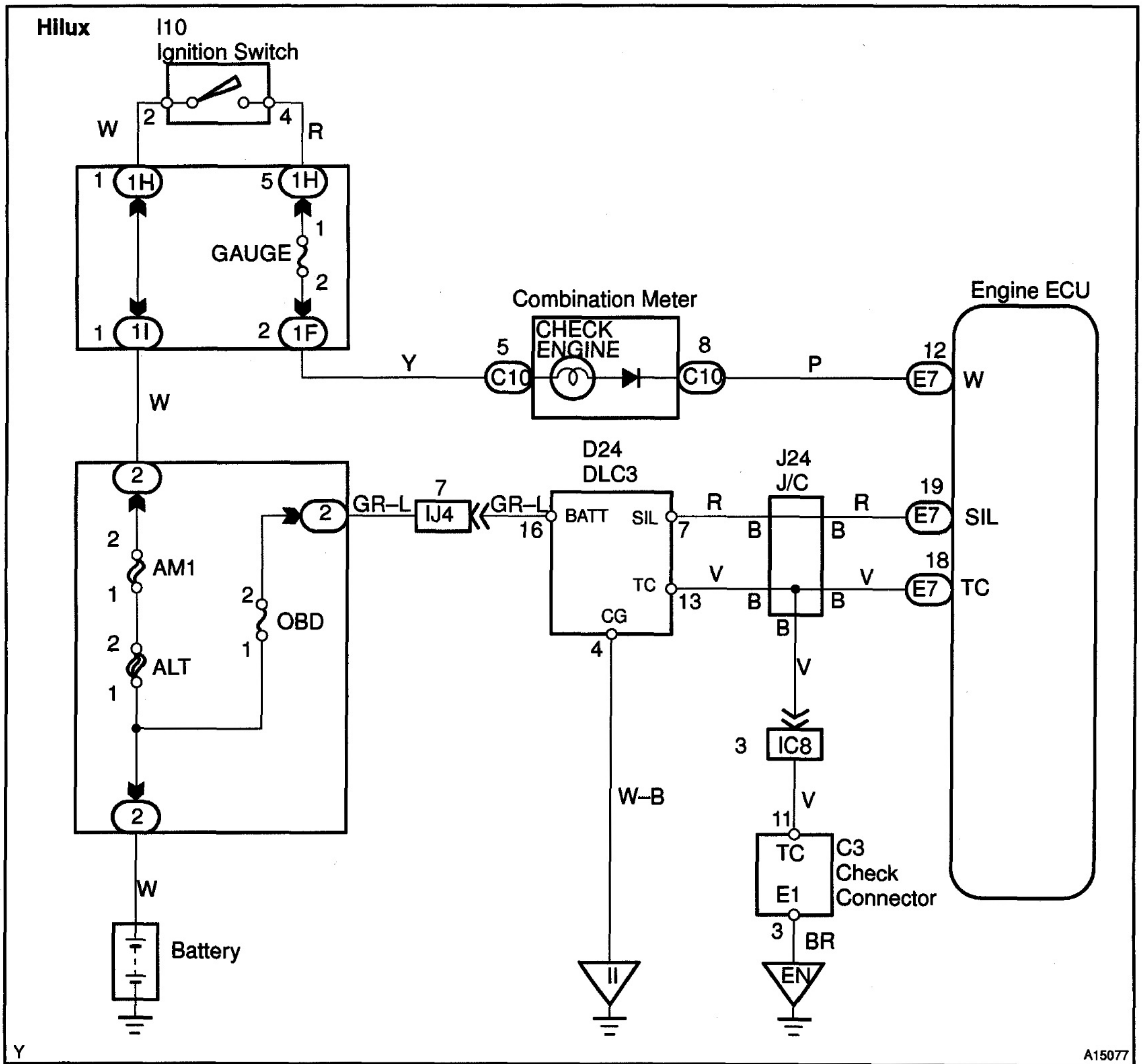

4Runner

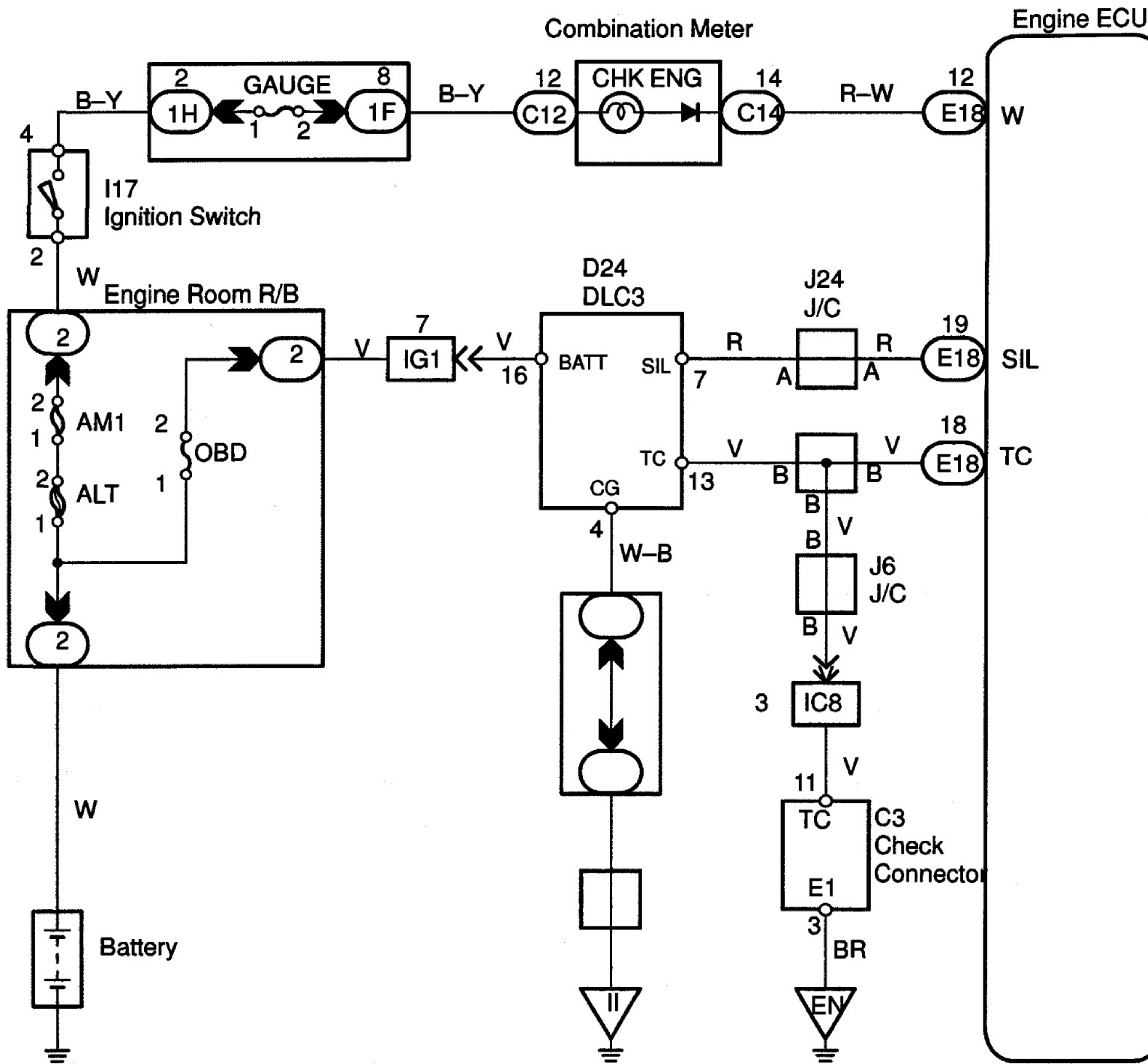

P

A15421

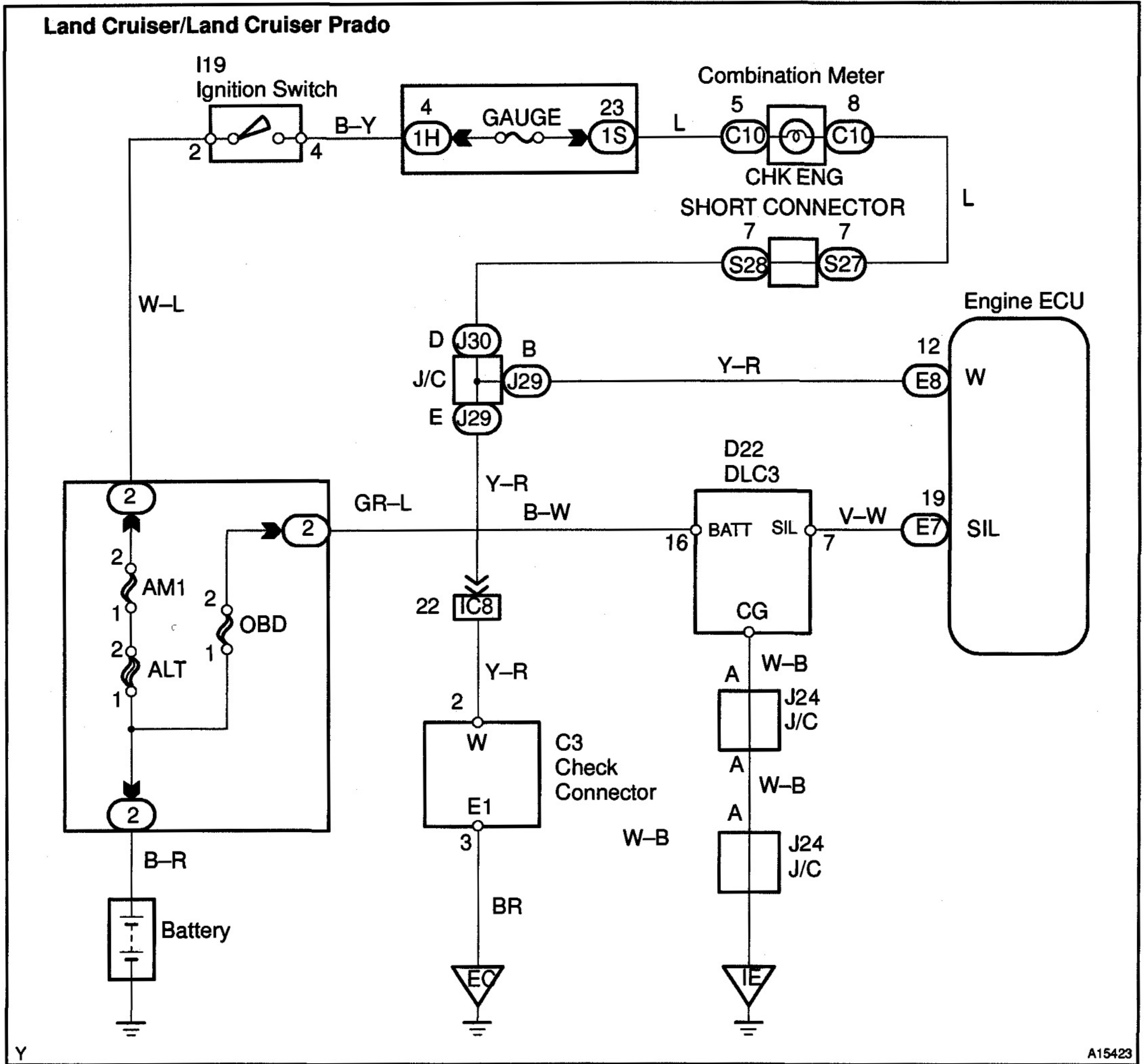

INSPECTION PROCEDURE

1	Check check engine warning light condition.
----------	--

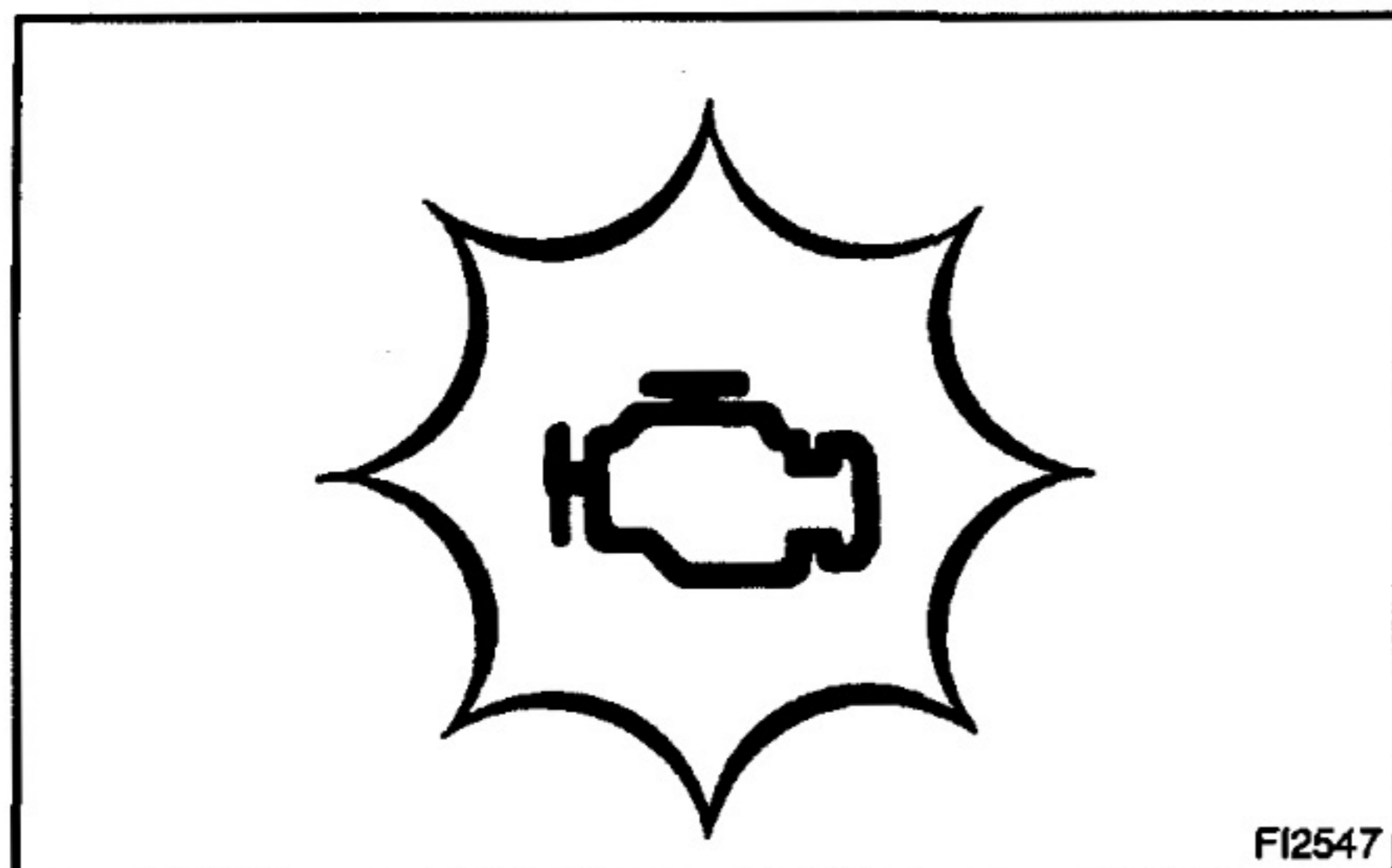

PREPARATION:

- (a) Turn the ignition switch ON.
- (b) Using SST, connect terminals TC and CG of the DLC3.
SST 09843-18040

CHECK:

Check the check engine warning light condition.

OK:

Check engine warning light: Blinking

HINT:

If this inspection is OK and there is no hand-held tester, the following steps are unnecessary because this circuit is OK. Proceed to next circuit inspection shown on problem symptoms table (See page DI-24).

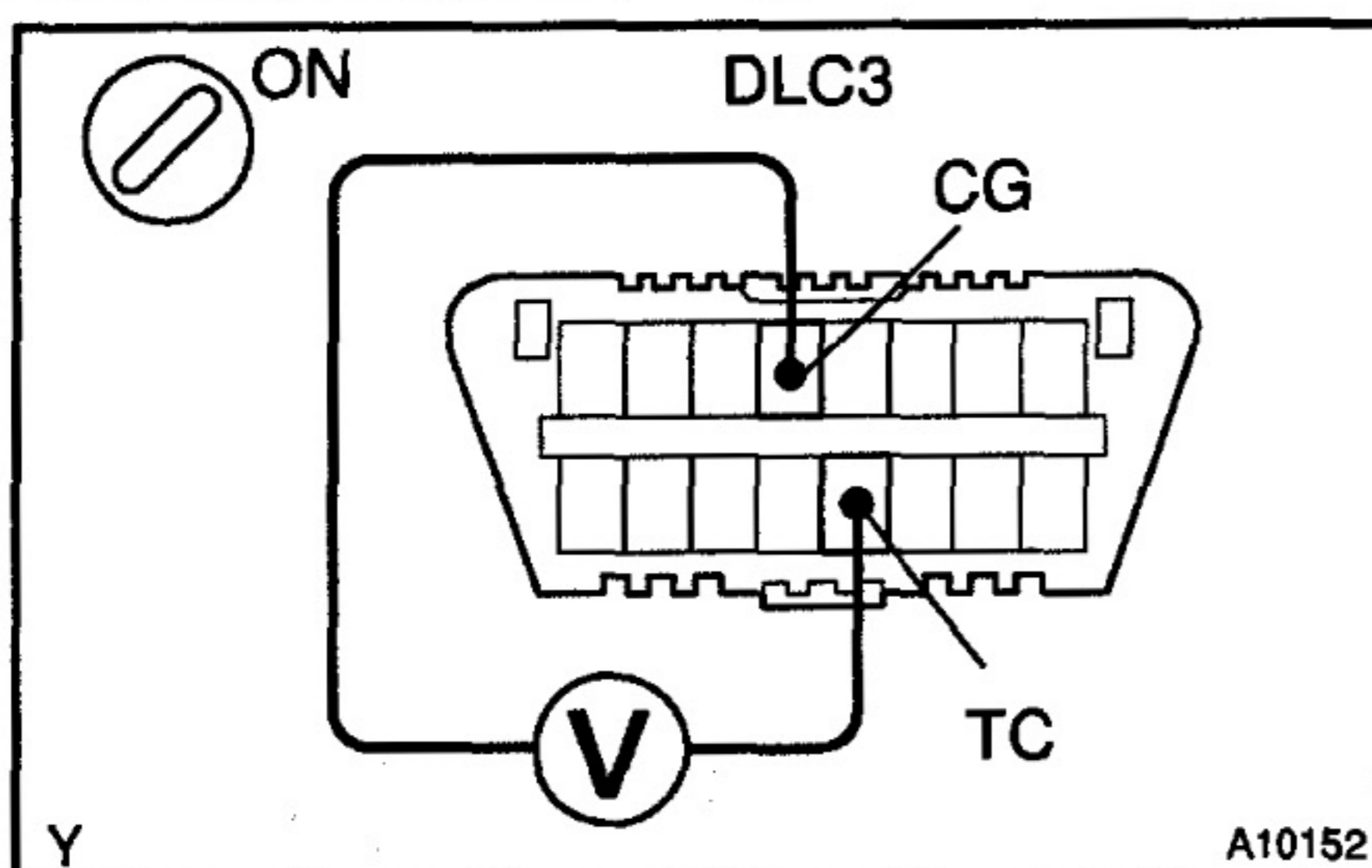
OK**Go to step 7.****NG****2****Check voltage between terminals TC and CG of DLC3.****PREPARATION:**

Turn the ignition switch ON.

CHECK:

Measure the voltage between terminals TC and CG of the DLC3.

OK:

Voltage: 9 - 14 V

OK**Go to step 5.****NG****3****Check continuity terminal CG of DLC3 and body ground.****NG****Repair or replace harness or connector.****OK****4****Check for open and short in harness and connector between terminal TC of DLC3 and terminal TC of engine ECU (See page IN-20).****NG****Repair or replace harness or connector.****OK**

Check and replace engine ECU.

5 Check voltage between terminal W of engine ECU connector and body ground.

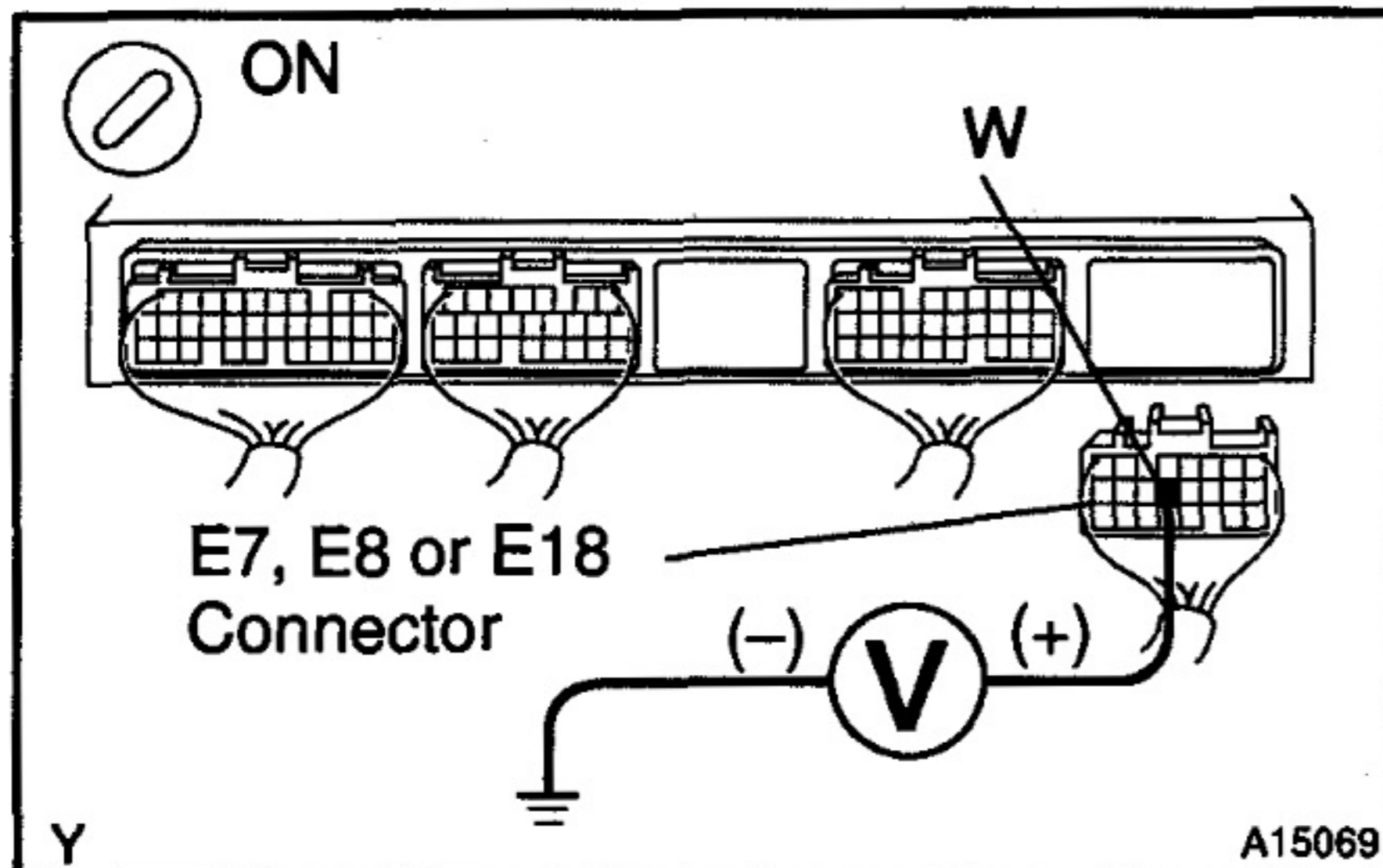

PREPARATION:

- Remove the glove compartment door.
- Disconnect the E7 (Hilux), E8 (Land Cruiser/Land Cruiser Prado) or E18 (4Runner) connector of the engine ECU.
- Turn the ignition switch ON.

CHECK:

Measure the voltage between terminal W of the engine ECU connector and the body ground.

OK:

Voltage: 9 – 14 V

OK

Check and replace engine ECU (See page IN-20).

NG

6 Check bulb of check engine warning light.

NG

Replace bulb.

OK

Check for open in harness and connector between terminal W of engine ECU and combination meter (See page IN-20).

7 Can you read DTC (including normal DTC) using hand-held tester?

YES

Proceed to next circuit inspection shown on problem symptoms table (See page DI-24).

NO

8

Check voltage between terminal BATT of DLC3 and body ground.

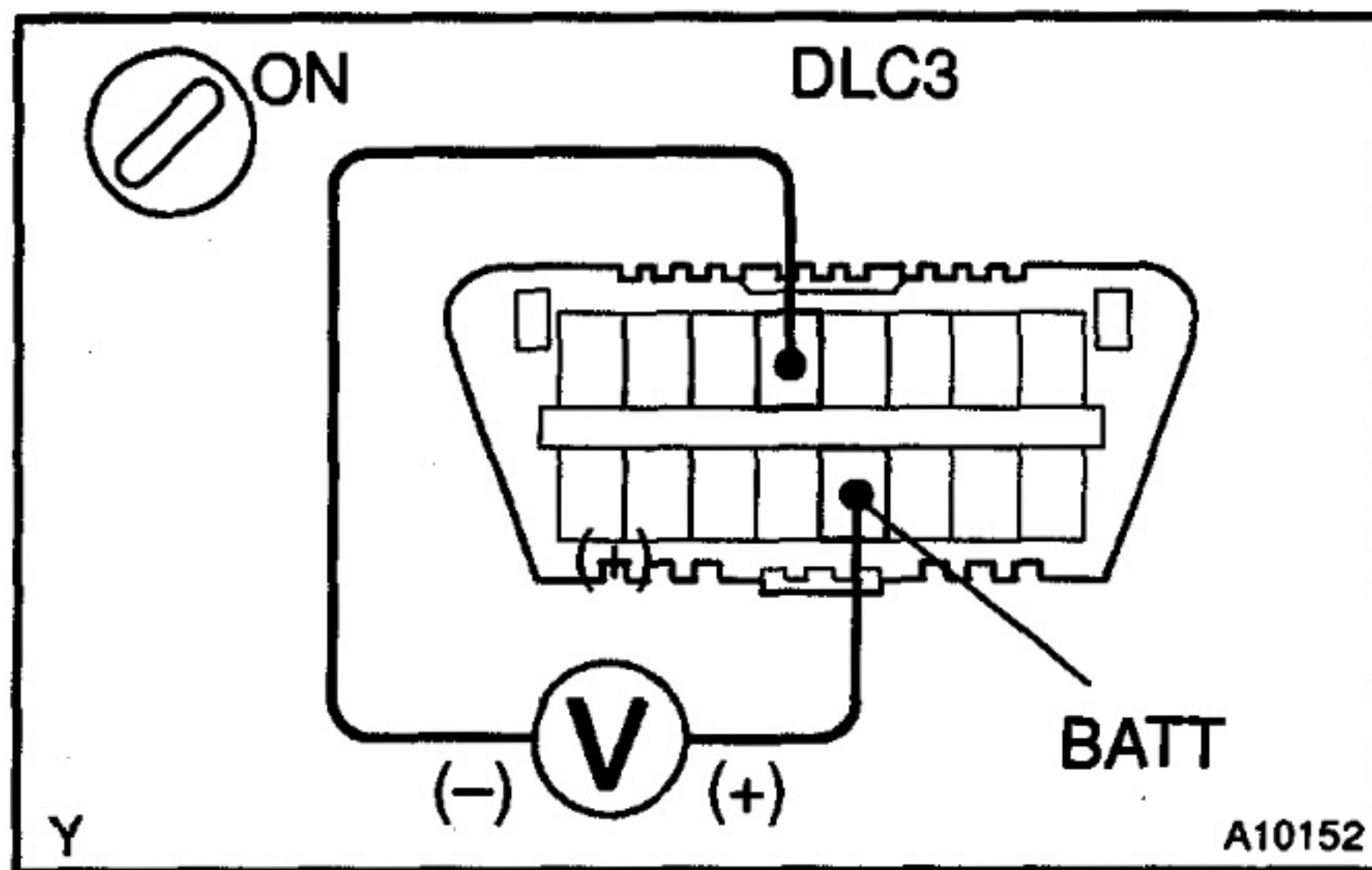
**CHECK:**

Measure the voltage between terminal BATT of the DLC3 and the body ground.

OK:

Voltage: 9 - 14 V

NG

Check for open and short in harness and connector between terminal BATT of DLC3 and fusible link block (See page IN-20).

OK

Check for open and short in harness and connector between terminal SIL of DLC3 and terminal SIL of engine ECU (See page IN-20).

4Runner

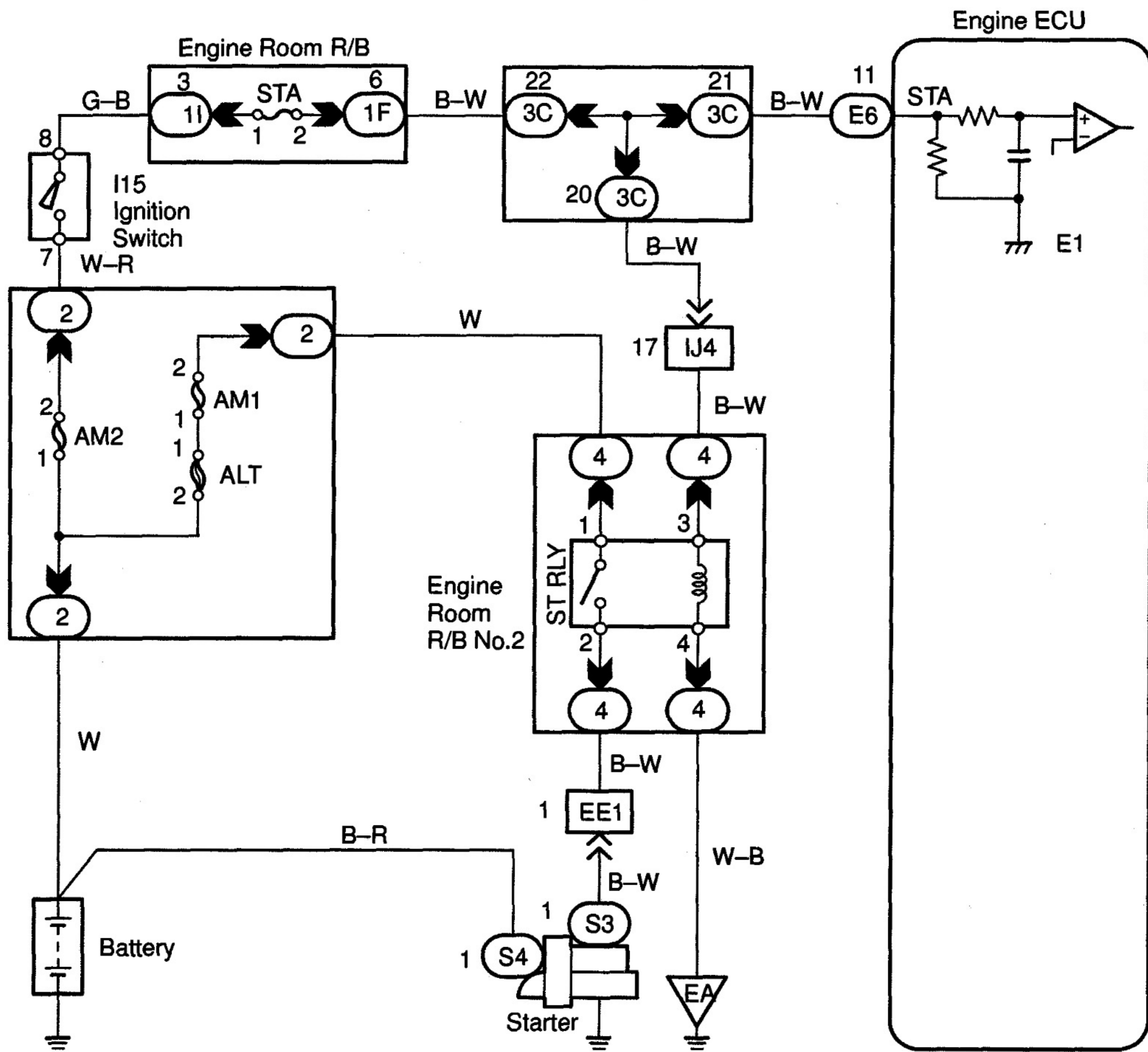

Land Cruiser/Land Cruiser Prado

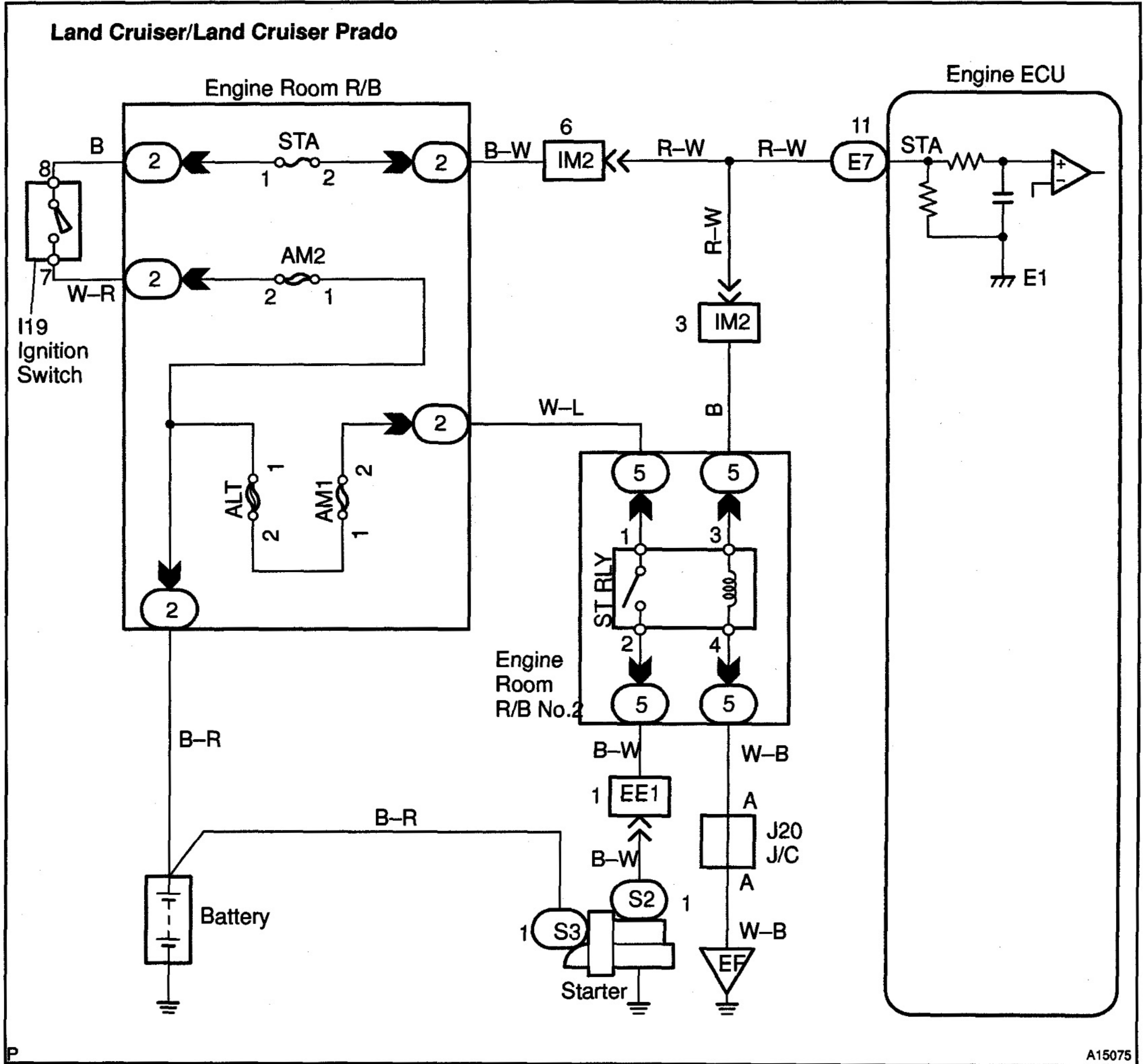

P

A15075

INSPECTION PROCEDURE**HINT:**

This diagnostic chart is based on the premise that the engine is being cranked under the normal conditions. If the engine does not crank, proceed to the problem symptoms table on page DI-24.

When using hand-held tester:

1	Connect hand-held tester and check STA signal.
----------	---

PREPARATION:

- (a) Connect the hand-held tester to the DLC3.
 (b) Turn the ignition switch ON and push the hand-held tester main switch ON.

CHECK:

Read the STA signal on the hand-held tester while the starter is operating.

OK:

Ignition Switch Position	ON	STA
STA Signal	OFF	ON

OK

Proceed to next circuit inspection shown on problem symptoms table (See page DI-24).

NG

2	Check for open in harness and connector between engine ECU and starter relay (Marking : ST RLY for Land Cruiser/Land Cruiser Prado or ST for Hilux and 4Runner) (See page IN-20).
----------	--

NG

Repair or replace harness or connector.

OK

Check and replace engine ECU.

When not using hand-held tester:

1	Check voltage between terminal STA of engine ECU connector and body ground.
----------	--

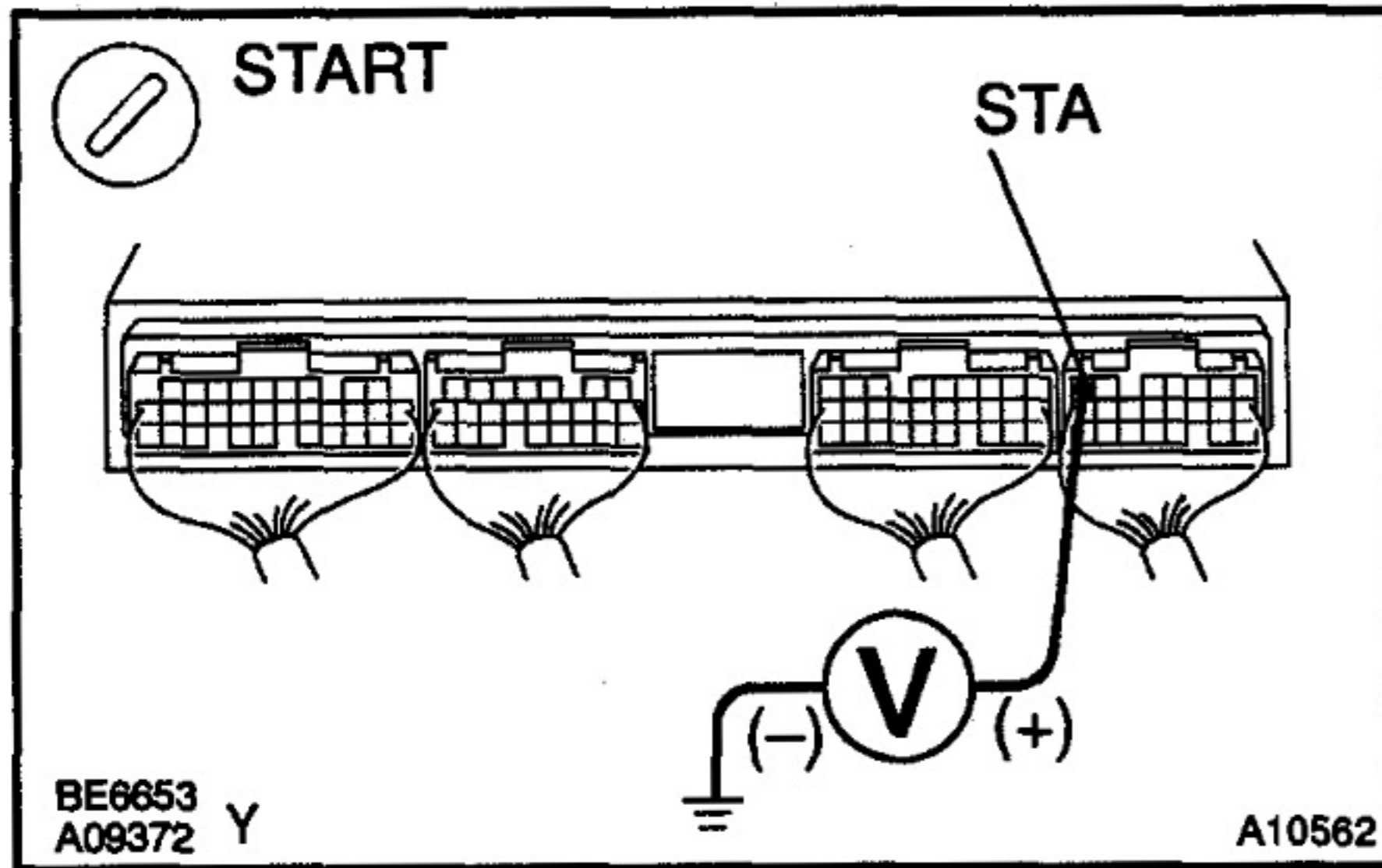
**PREPARATION:**

- (a) Remove the glove compartment door.
- (b) Turn the ignition switch ON.

CHECK:

Measure the voltage between terminal STA of the engine ECU connector and the body ground during cranking.

OK:

Voltage: 6.0 V or more

OK

Proceed to next circuit inspection shown on problem symptoms table (See page DI-24).

NG

2	Check for open in harness and connector between engine ECU and starter relay (Marking : ST RLY for Land Cruiser/Land Cruiser Prado or ST for Hilux and 4Runner) (See page IN-20).
----------	--

NG

Repair or replace harness or connector.

OK

Check and replace engine ECU.

EGR Control Circuit

CIRCUIT DESCRIPTION

The EGR system recirculates exhaust gas, which is controlled to the proper quantity to suit the driving conditions into the intake air mixture to slow down combustion, reduce the combustion temperature and reduce NOx emissions. The lift amount of the EGR valve is controlled by the vacuum which is regulated by the E-VRV operated by the engine ECU.

If even one of the following conditions is fulfilled, the E-VRV for EGR is turned ON by a signal from the ECU. This results in atmospheric air acting on the EGR valve, closing the EGR valve and shutting off the exhaust gas (EGR cutoff).

Under the following conditions, the EGR is cut to maintain driveability.

- Before the engine is warmed up
- During deceleration (Diesel throttle valve closed)
- Light engine load (very small amount of intake air)
- Engine speed over 3,000 rpm

WIRING DIAGRAM

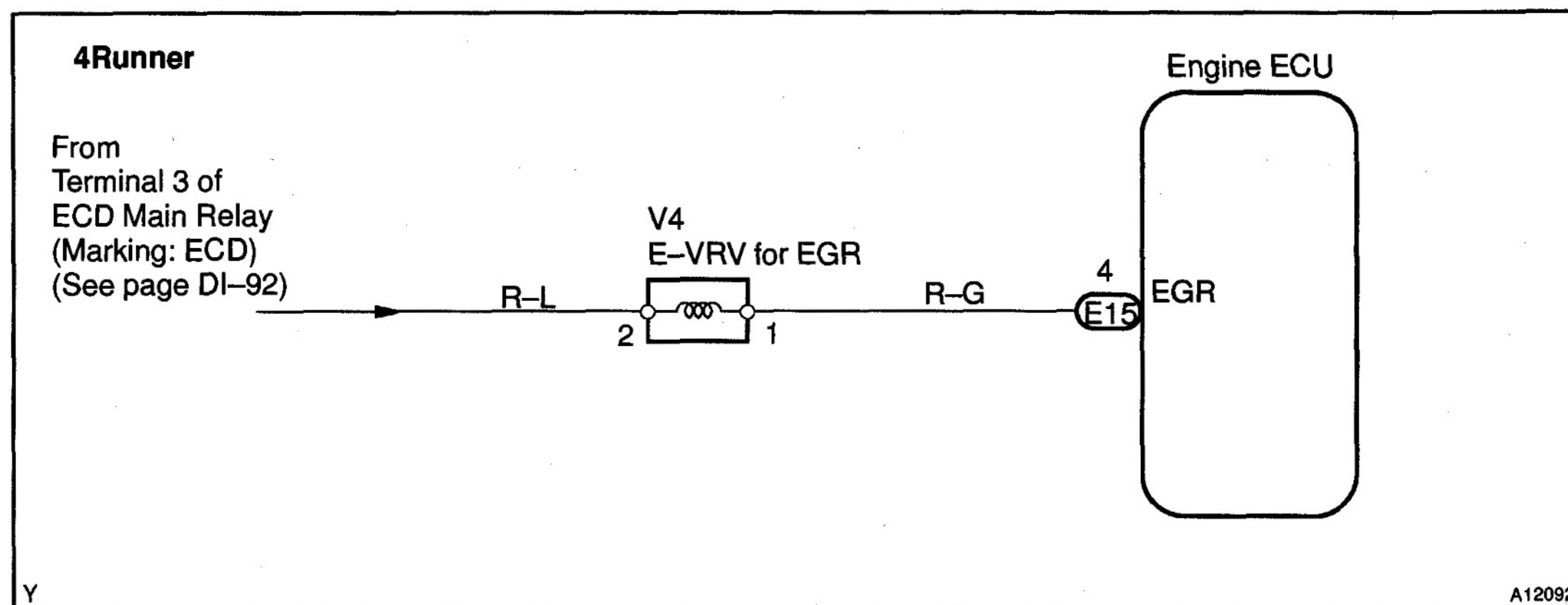
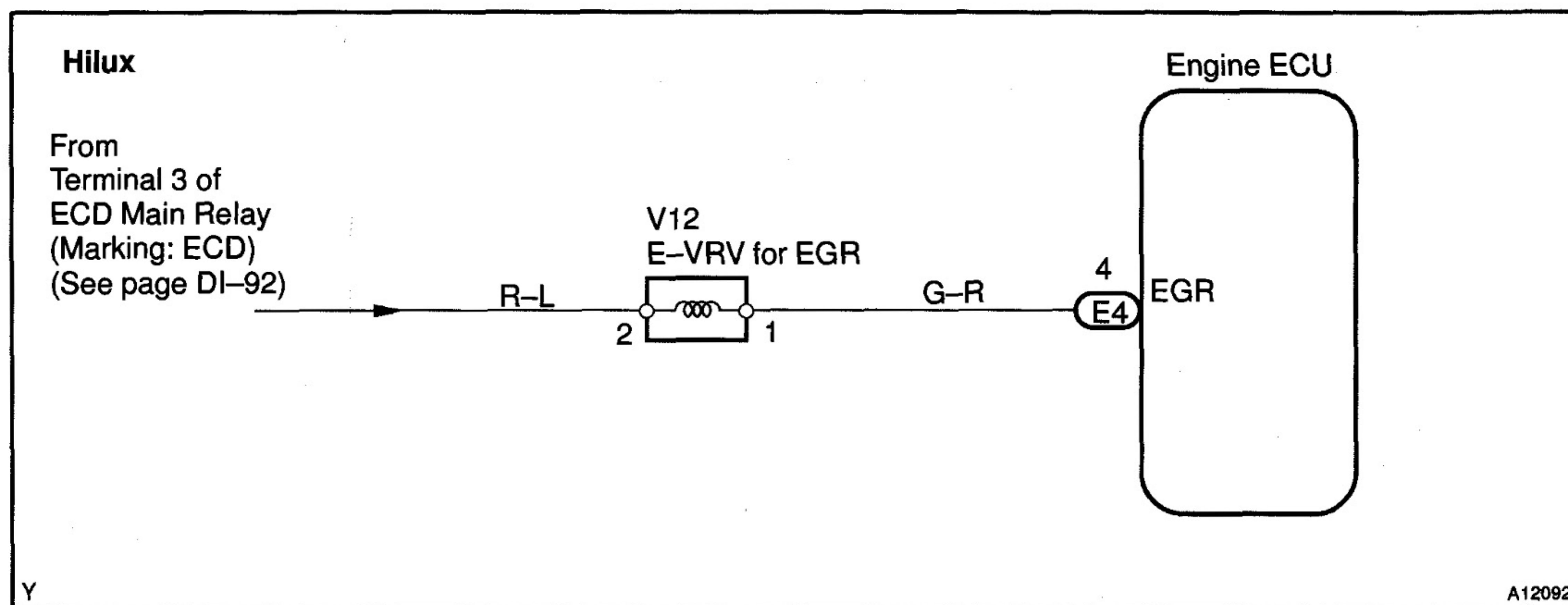

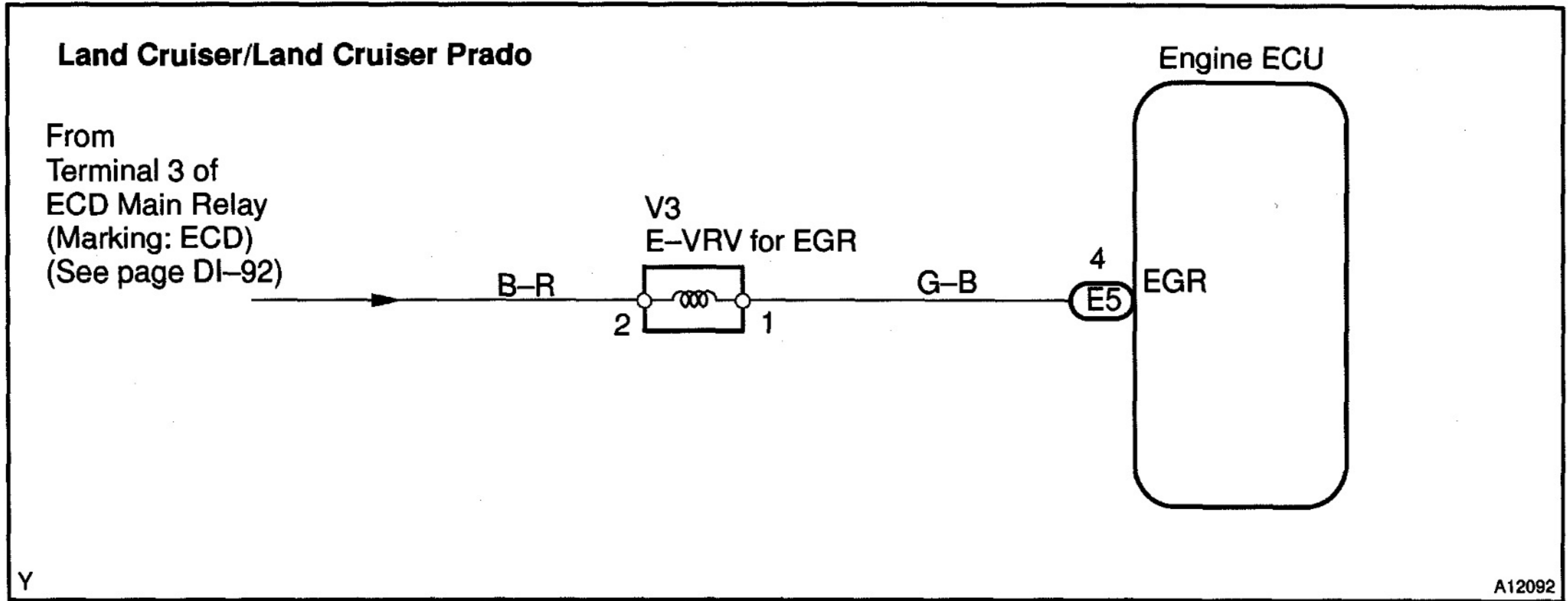

INSPECTION PROCEDURE

When using hand-held tester:

1	Check connection of vacuum hose.
---	----------------------------------

NG
Repair or replace.

OK

2	Check voltage between terminal EGR of engine ECU and body ground.
---	---

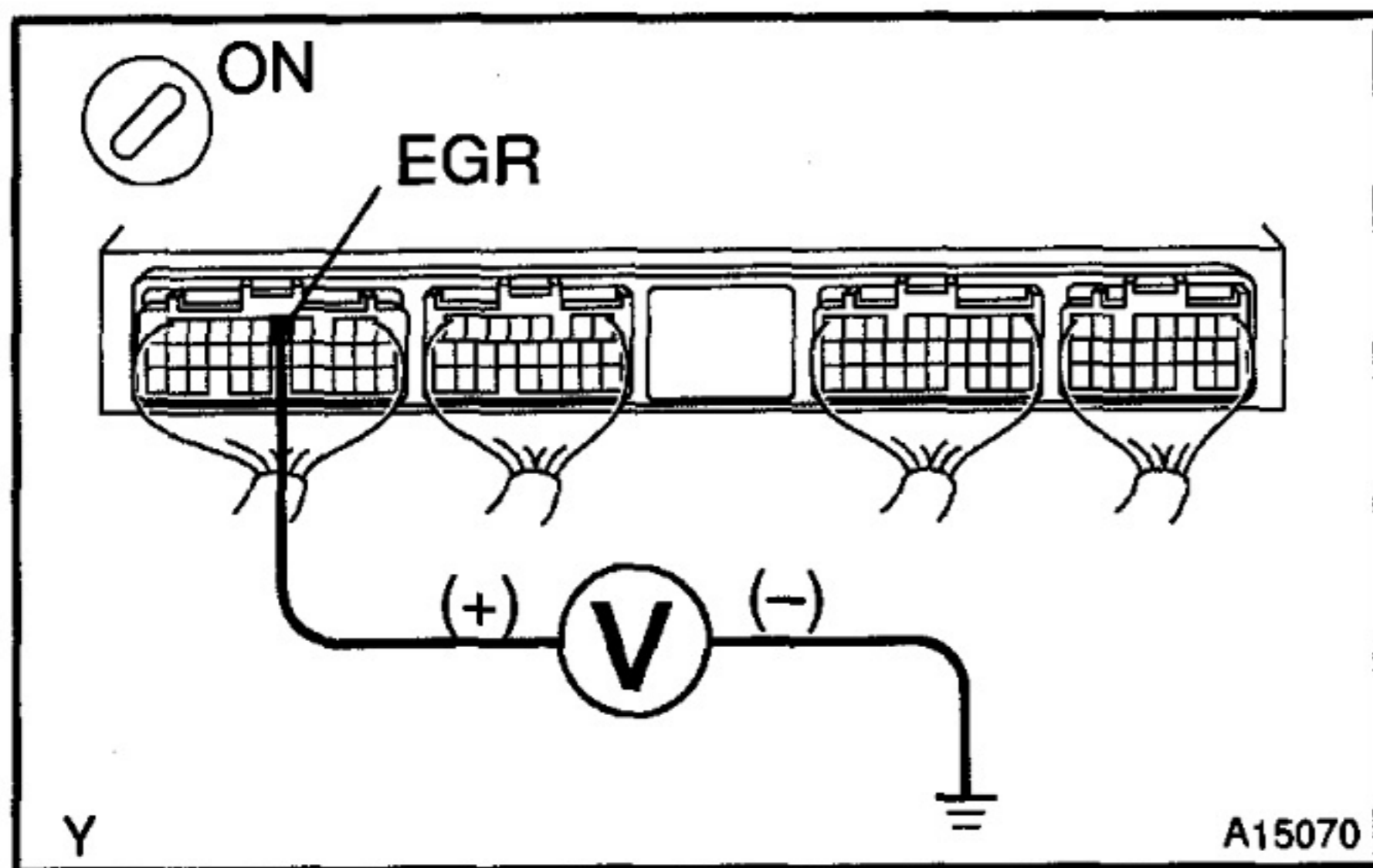

PREPARATION:

- (a) Remove the glove compartment door.
- (b) Turn the ignition switch ON.

CHECK:

Measure the voltage between terminal EGR of the engine ECU connector and the body ground.

OK:

Voltage: 9 - 14 V

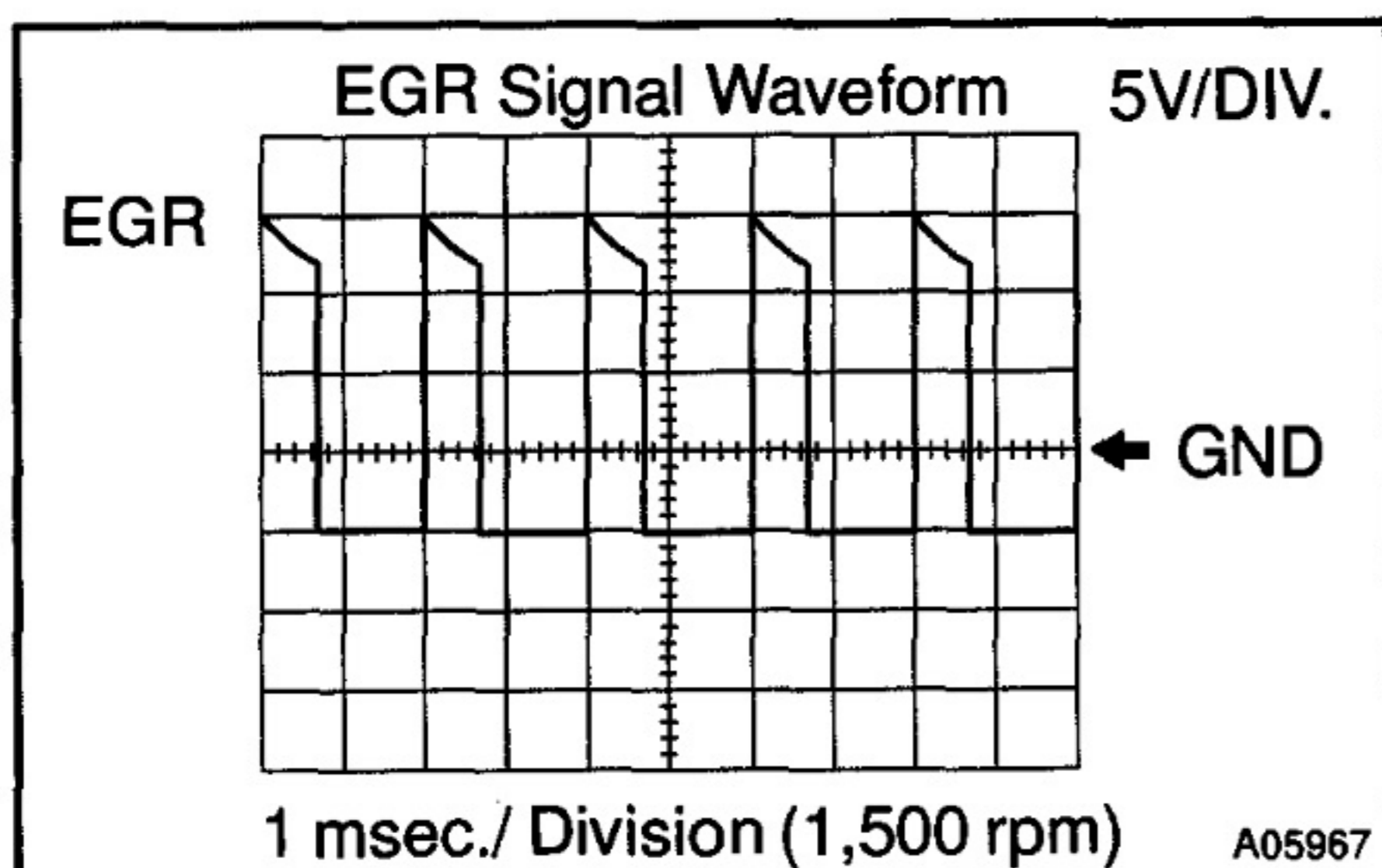

Reference: INSPECTION USING OSCILLOSCOPE

While EGR system is ON (engine speed 1,500 rpm), check the waveform between terminals EGR and E1 of the engine ECU connector.

HINT:

The correct waveform is as shown.

NG

Check and replace engine ECU (See page IN-20).

OK

3

Check operation of E-VRV for EGR.

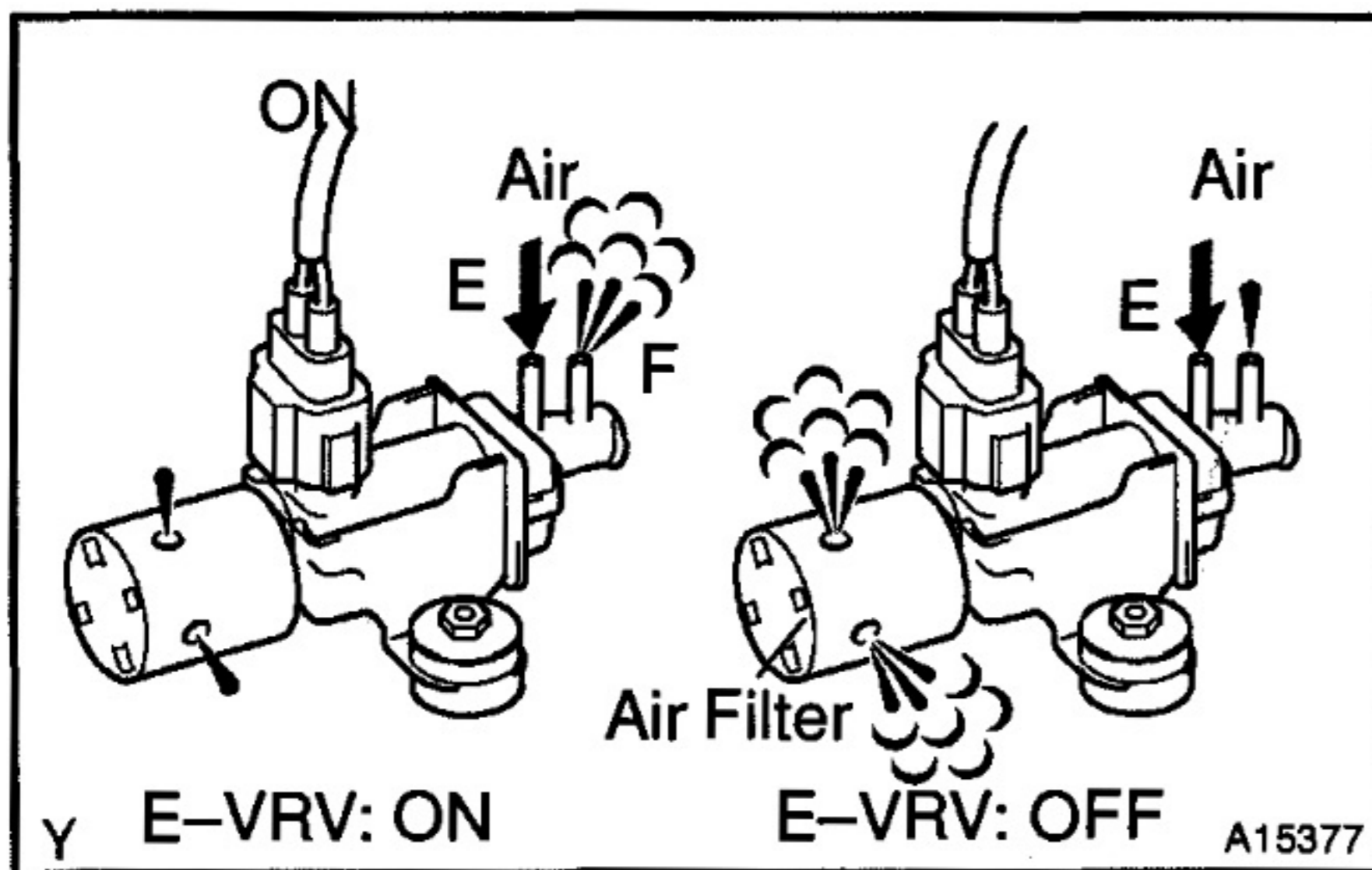
**PREPARATION:**

- Disconnect the vacuum hoses from the E-VRV.
- Connect the hand-held tester to the DLC3.
- Turn the ignition switch ON and push the hand-held tester main switch ON.
- Select the ACTIVE TEST mode on the hand-held tester.

CHECK:

Check the operation of the E-VRV when it is operated by the hand-held tester.

OK:

E-VRV ON:

Air from port E is flows out through port F.

E-VRV OFF:

Air from port E is flows out through air filter.

OK

Go to step 10.

NG

4

Check E-VRV for EGR (See page EC-3).

NG

Replace E-VRV for EGR.

OK

5

Check for open and short in harness and connector between E-VRV and engine ECU, and E-VRV and ECD main relay (Marking: ECD) (See page IN-20).

NG

Repair or replace harness or connector.

OK

6	Check EGR valve (See page EC-3).
---	----------------------------------



Replace EGR valve.



Check and replace engine ECU (See page IN-20).

When not using hand-held tester:

1	Check connection of vacuum hose.
---	----------------------------------



Repair or replace.



2	Check voltage between terminal EGR of engine ECU connector and body ground (See page DI-109, Step 5).
---	---



Check and replace engine ECU (See page IN-20).



3 Check operation of E-VRV for EGR.

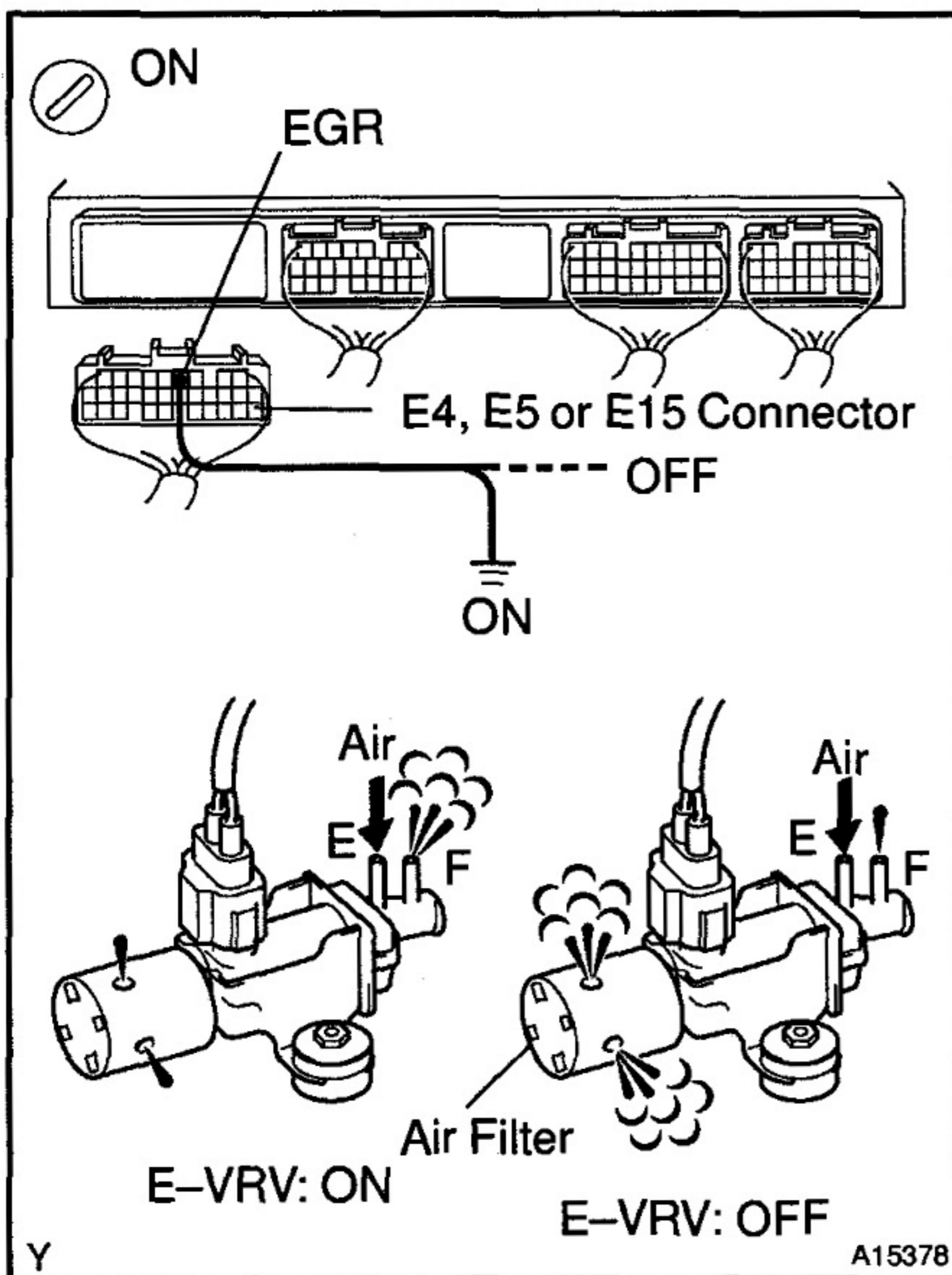

PREPARATION:

- Remove the glove compartment door.
- Disconnect the E4 (Hilux), E5 (Land Cruiser Land Cruiser Prado) or E15 (4Runner) connector of the engine ECU.
- Turn the ignition switch ON.

CHECK:

Check the E-VRV operation.

- Connect terminal EGR of the engine ECU connector and the body ground (ON).
- Disconnect terminal EGR of the engine ECU connector and the body ground (OFF).

OK:

E-VRV ON:

Air from port E flows out through port F.

E-VRV OFF:

Air from port E flows out through air filter.

OK

Go to step 9.

NG

4 Check E-VRV for EGR (See page EC-3).

NG

Replace E-VRV for EGR.

OK

5 Check for open and short in harness and connector between E-VRV for EGR and engine ECU, and E-VRV for EGR and ECD main relay (Marking: ECD) (See page IN-20).

NG

Repair or replace harness or connector.

OK

6	Check EGR valve (See page EC-3).
----------	---

NG

Replace EGR valve.

OK

Check and replace engine ECU (See page IN-20).

Pre-heating Control Circuit

CIRCUIT DESCRIPTION

When the ignition switch is turned ON, the engine ECU calculates the glow indicator lighting time/heating corresponding to the coolant temperature at that time and turns on the glow indicator light/glow plug relay. As ceramics is used for a glow plug material, the current control is impossible.

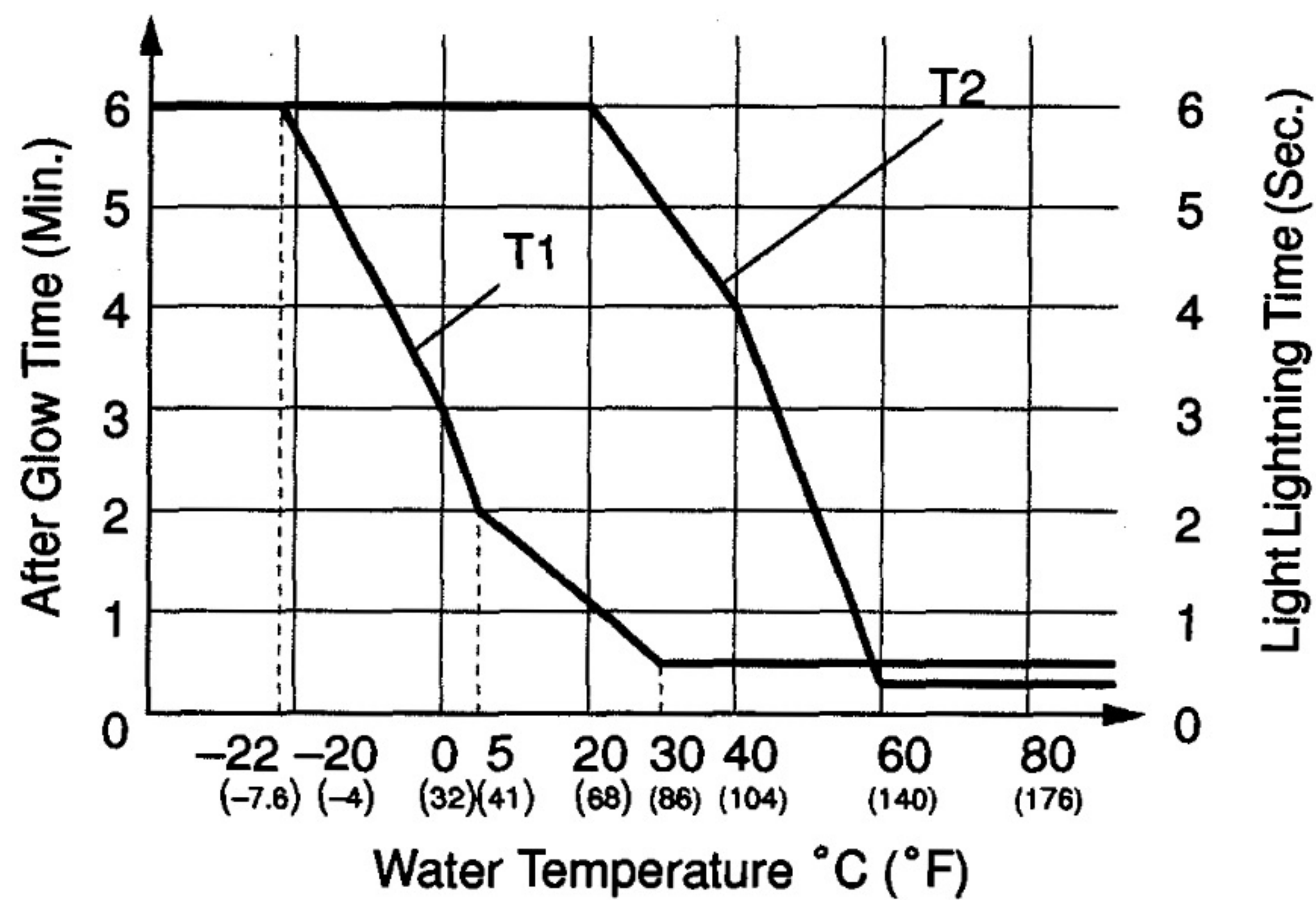

WIRING DIAGRAM

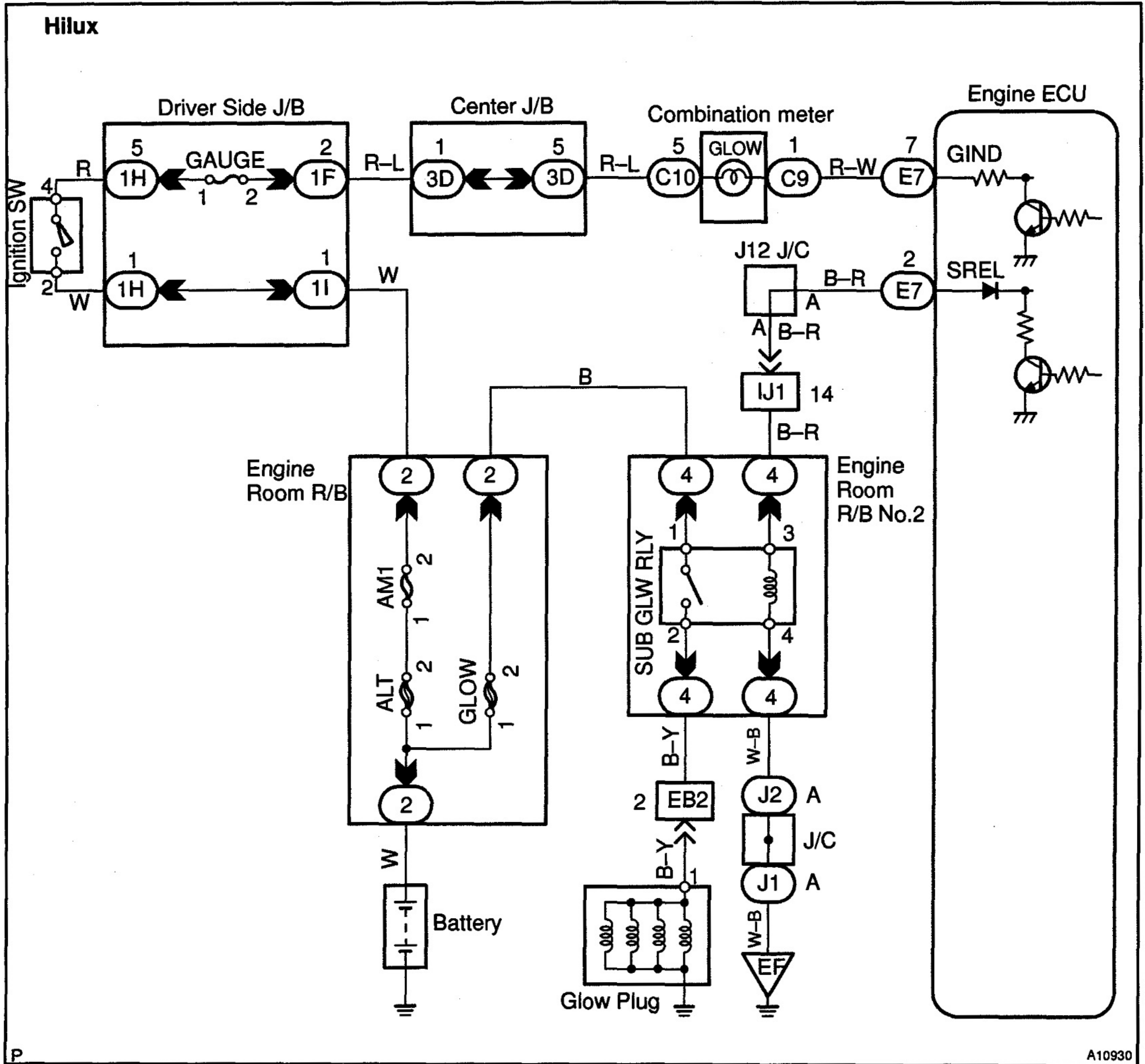

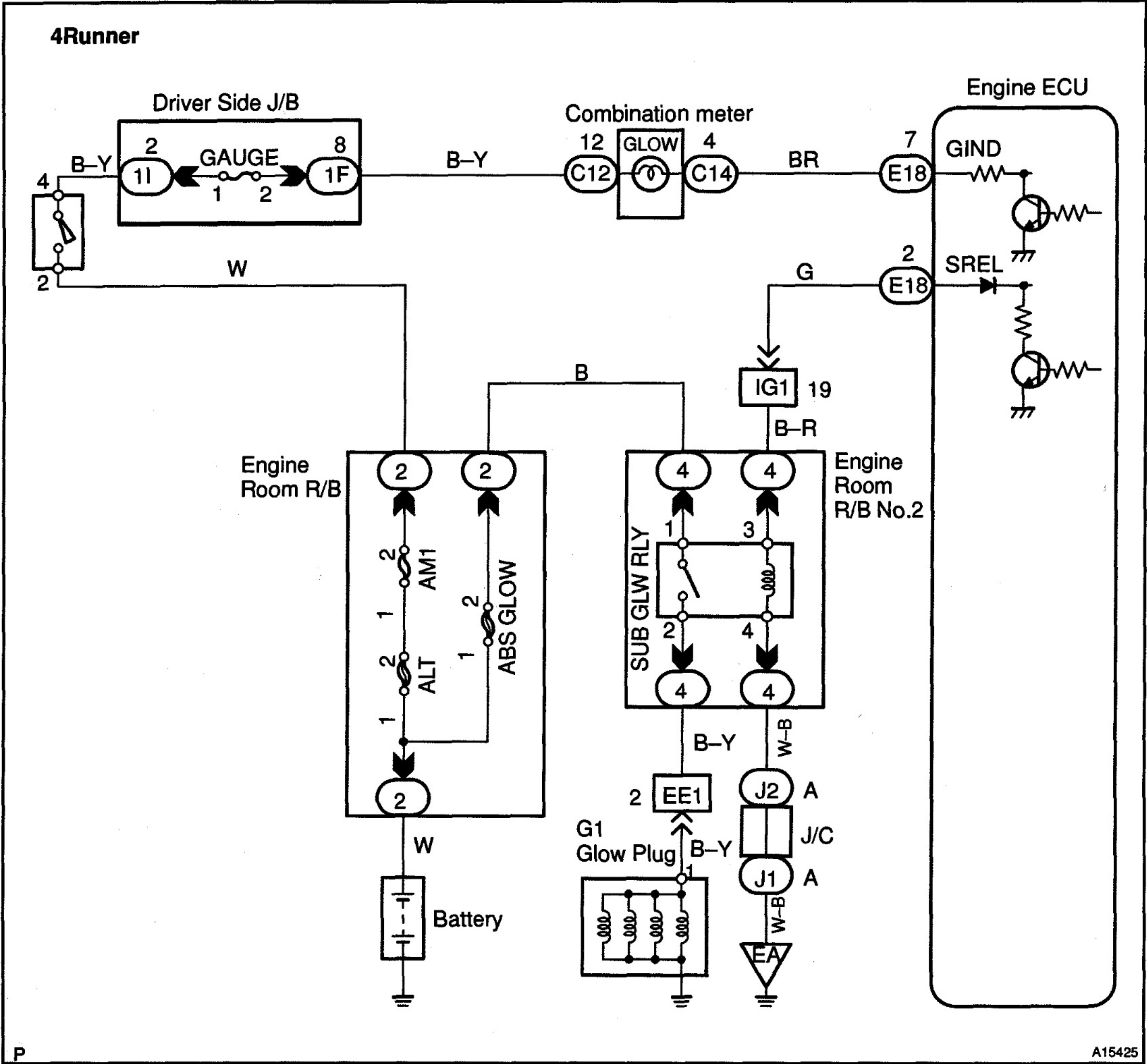

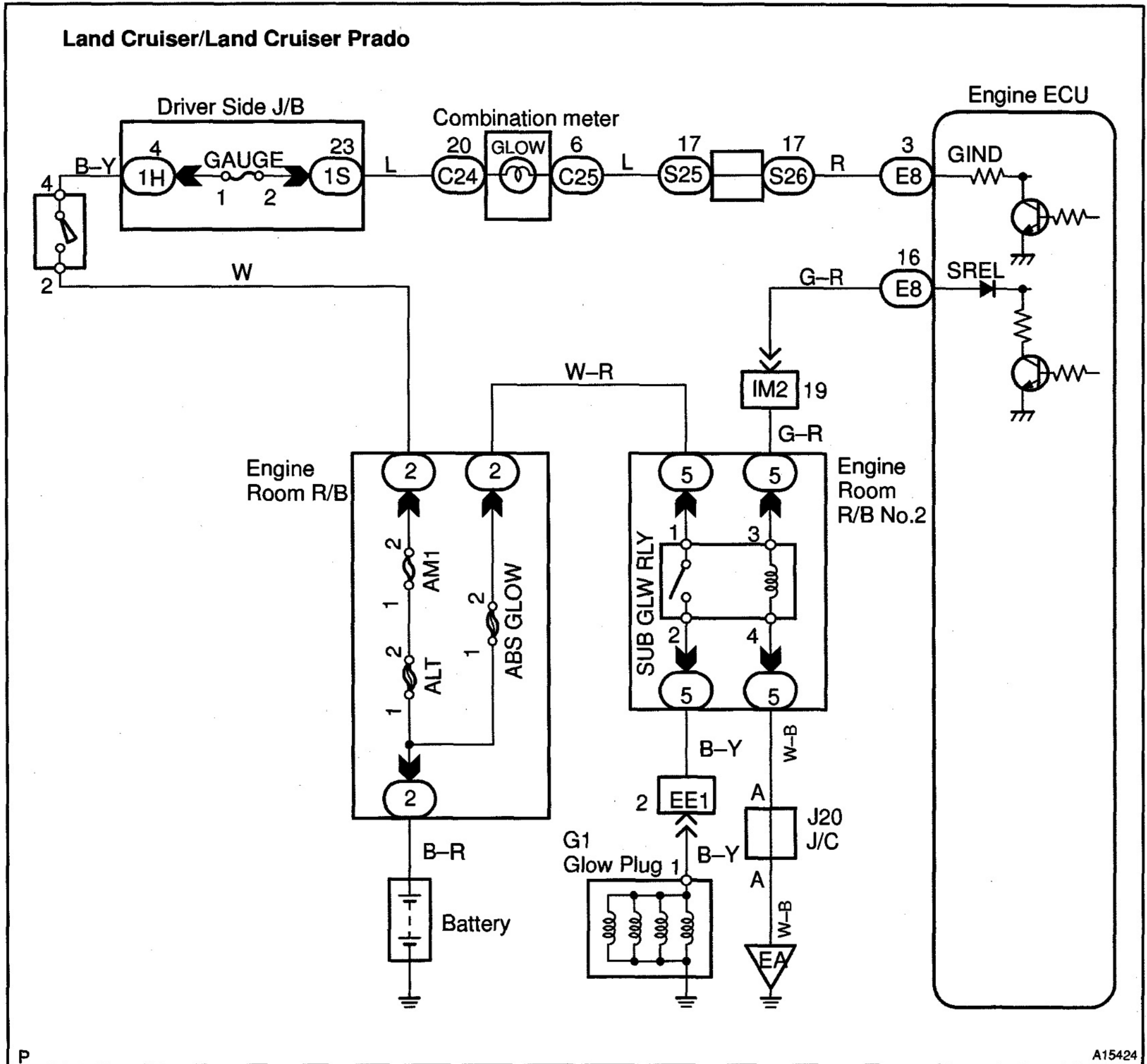

P

A15424

INSPECTION PROCEDURE

1	Does glow indicator light up?
---	-------------------------------

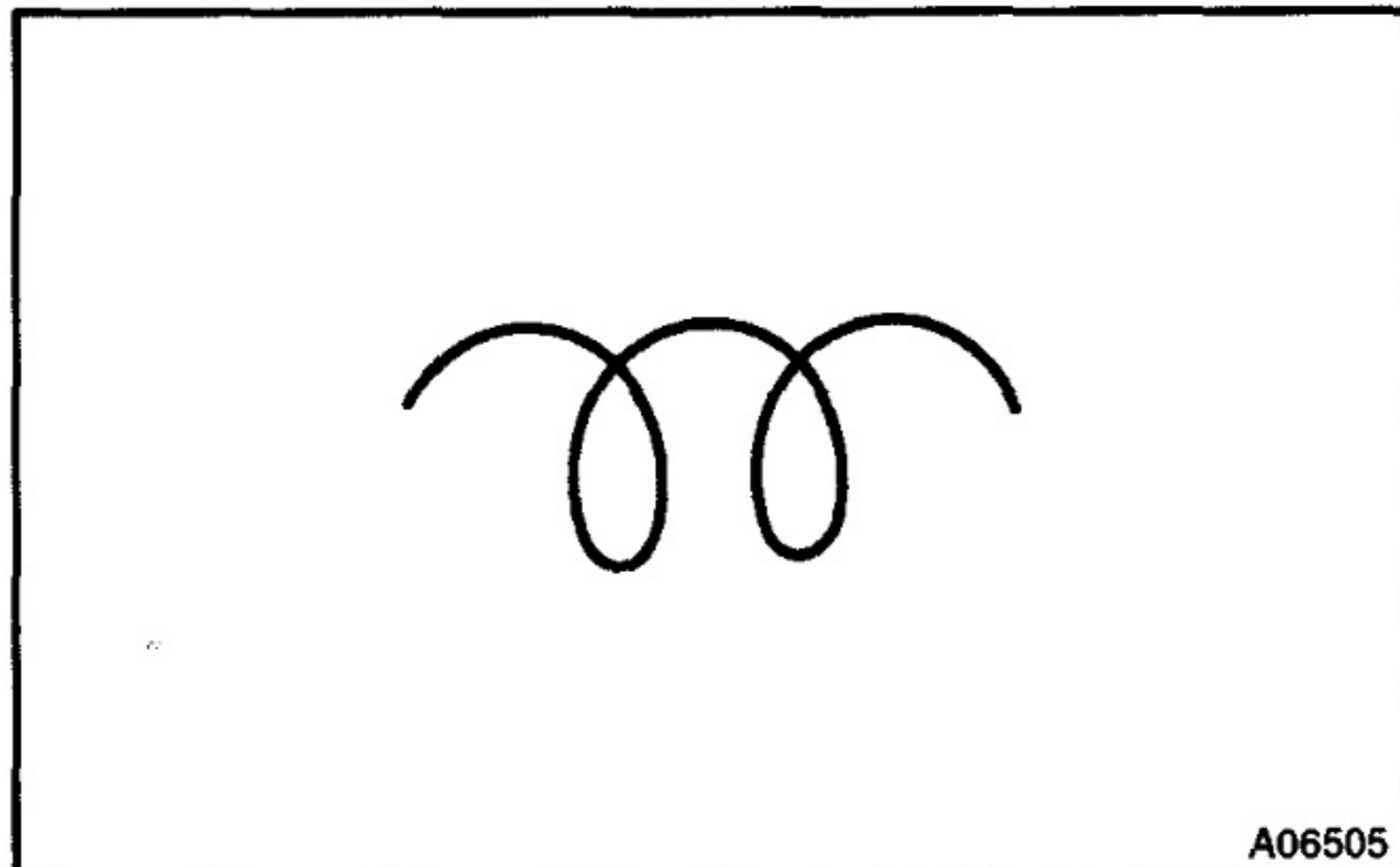

A06505

PREPARATION:

Turn the ignition switch ON.

CHECK:

Does the glow indicator light up?

OK:

The glow indicator lights up for 0.5 sec. or more.



Go to step 5.

NG

2 Check voltage between terminal GIND of engine ECU connector and body ground.

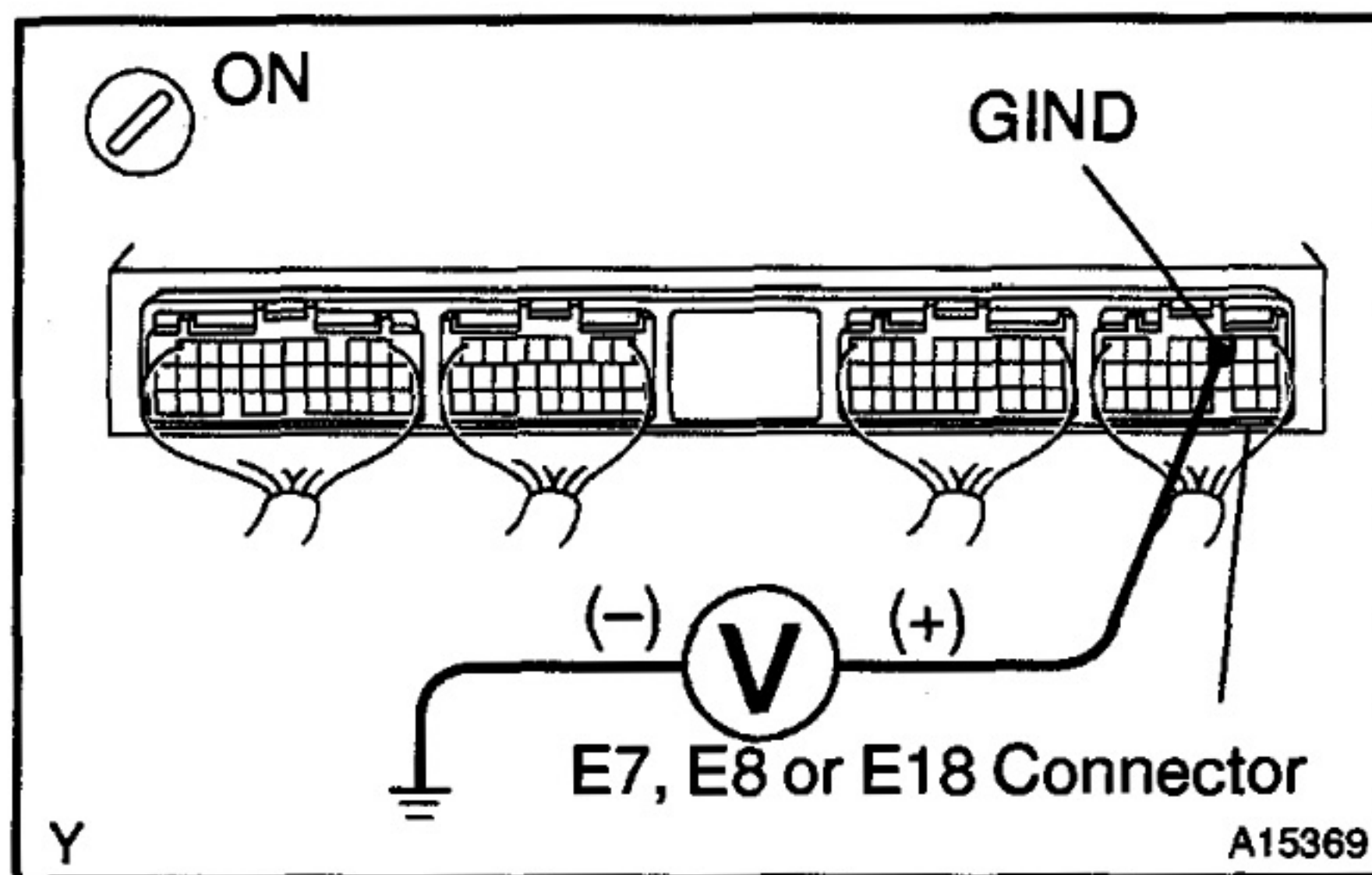
**PREPARATION:**

- Remove the glove compartment.
- Disconnect the E7 (Hilux), E8 (Land Cruiser/Land Cruiser/Prado) or E18 (4Runner) connector from the engine ECU.
- Turn the ignition switch ON.

CHECK:

Measure the voltage between terminal GIND of the engine ECU connector and the body ground.

OK:

Voltage: 9 – 14 V

OK

Check and replace engine ECU (See page IN-20).

NG

3 Check GAUGE fuse.

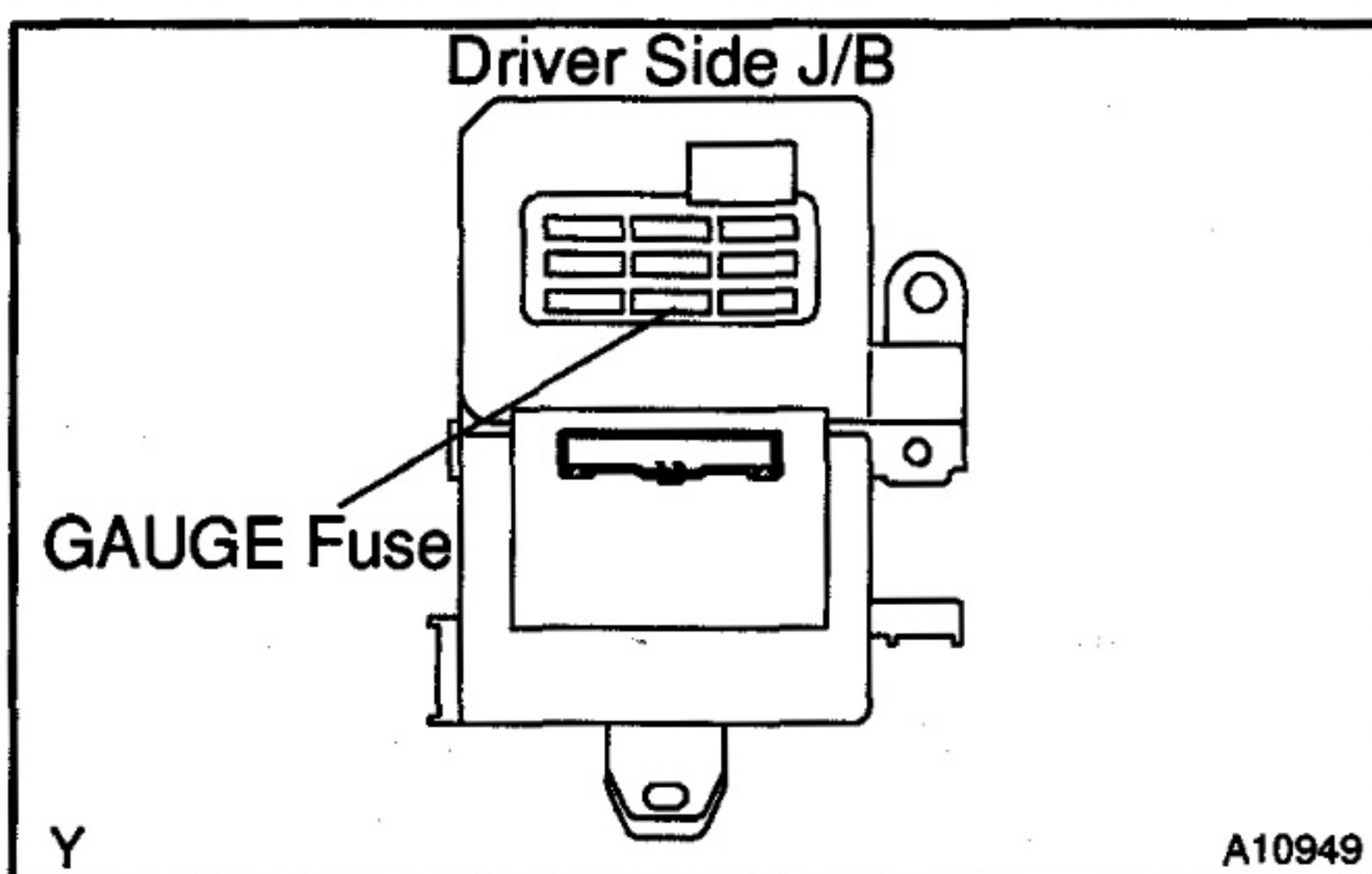
**PREPARATION:**

Remove the GAUGE fuse from the driver side J/B.

CHECK:

Check the continuity of the GAUGE fuse.

OK:

Continuity

NG

Replace GAUGE fuse.

OK

4 Check glow indicator light bulb.

NG

Replace bulb.

OK

Check for open in harness and connector between combination meter and engine ECU, and combination meter and GAUGE fuse (See page IN-20).

5 Check glow indicator lighting time (See page ST-1).

NG

Check and replace engine ECU (See page IN-20).

OK

6 Are there any DTC being output?

YES

Go to relevant DTC chart (See page DI-14).

NO

7 Check glow plug relay (Marking: SUB GLW RLY for Hilux and 4Runner, SUB GLW for Land Cruiser/Land Cruiser Prado) (See page ST-1).

NG

Replace glow plug relay.

OK

8 Check voltage between terminal SREL of engine ECU connector and body ground at cranking.

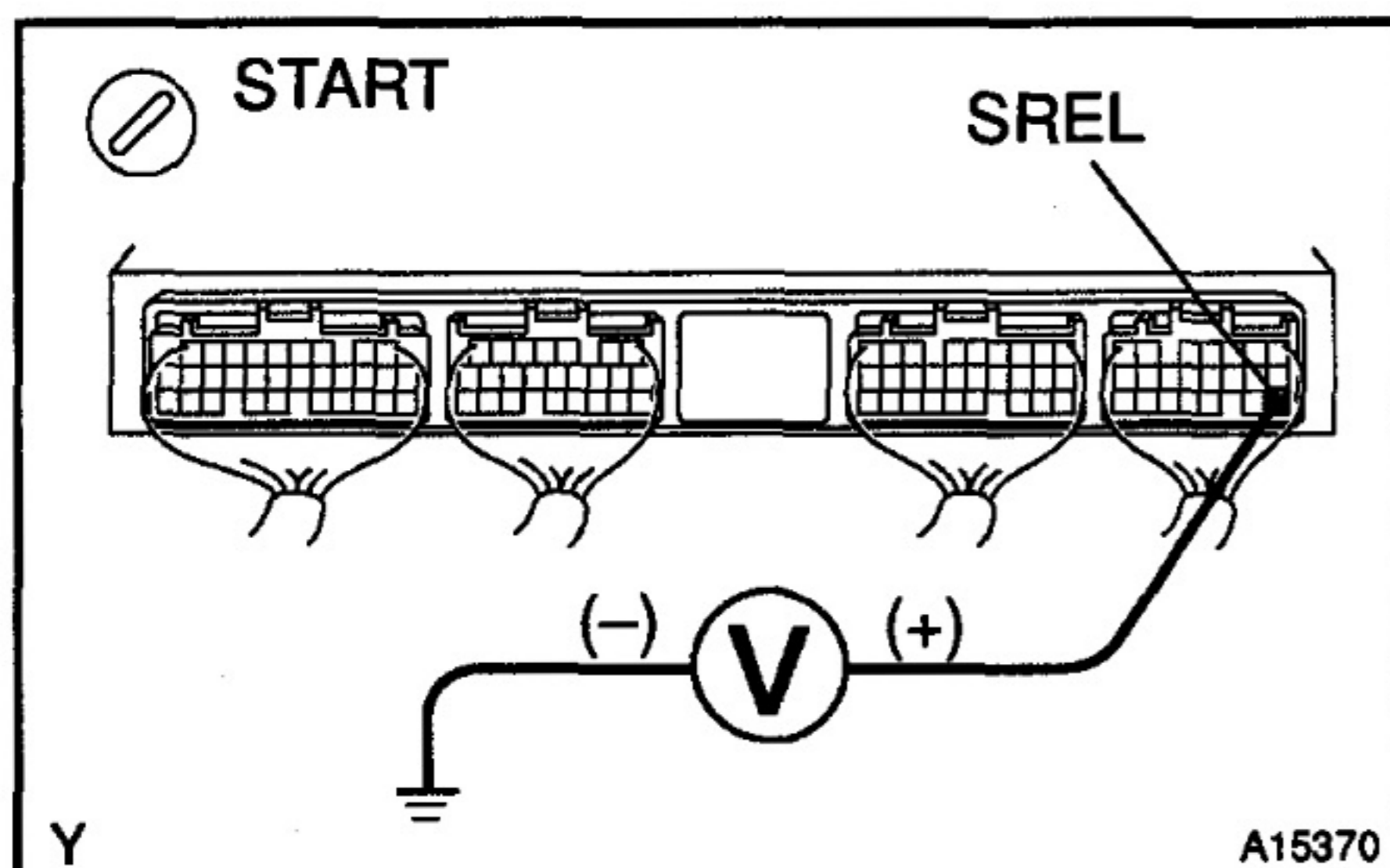

PREPARATION:

- Remove the glove compartment.
- Disconnect the E7 (Hilux), E8 (Land Cruiser/Land Cruiser Prado) or E18 (4Runner) connector from the engine ECU.
- Turn the ignition switch START.

CHECK:

Measure the voltage between terminal SREL of the engine ECU connector and the body ground at cranking.

OK:

Voltage: 9 - 14 V

NG Check and replace engine ECU (See page IN-20).

OK

9 Check for open and short in harness and connector between glow plug relay and engine ECU, and glow plug relay and body ground (See page IN-20).

NG Repair or replace harness or connector.

OK

10 Check resistance of glow plug (See Pub. No. RM710E, ST section).

NG Replace glow plug.

OK

11 Inspect glow plug installation.

NG Tighten glow plug.

OK

12 Check for open in harness and connector between glow plug relay and glow plug (See page IN-20).

NG Repair or replace harness or connector.

OK

Proceed to next circuit inspection shown on problem symptoms table (See page DI-24).

1st Gear Position Switch Circuit (only for M/T)

CIRCUIT DESCRIPTION

The shift position switch on the side of transmission detects the 1st gear and limits the engine output when high load is applied during the vehicle running in the 1st gear.

WIRING DIAGRAM

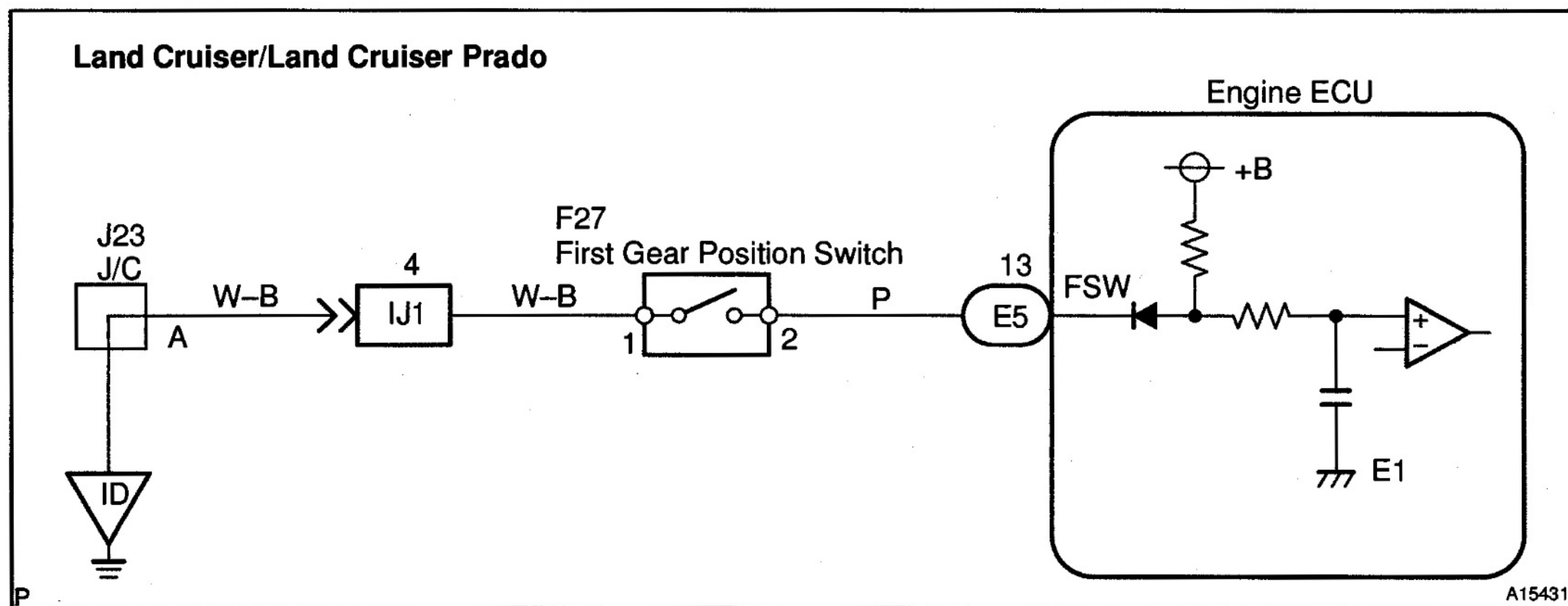
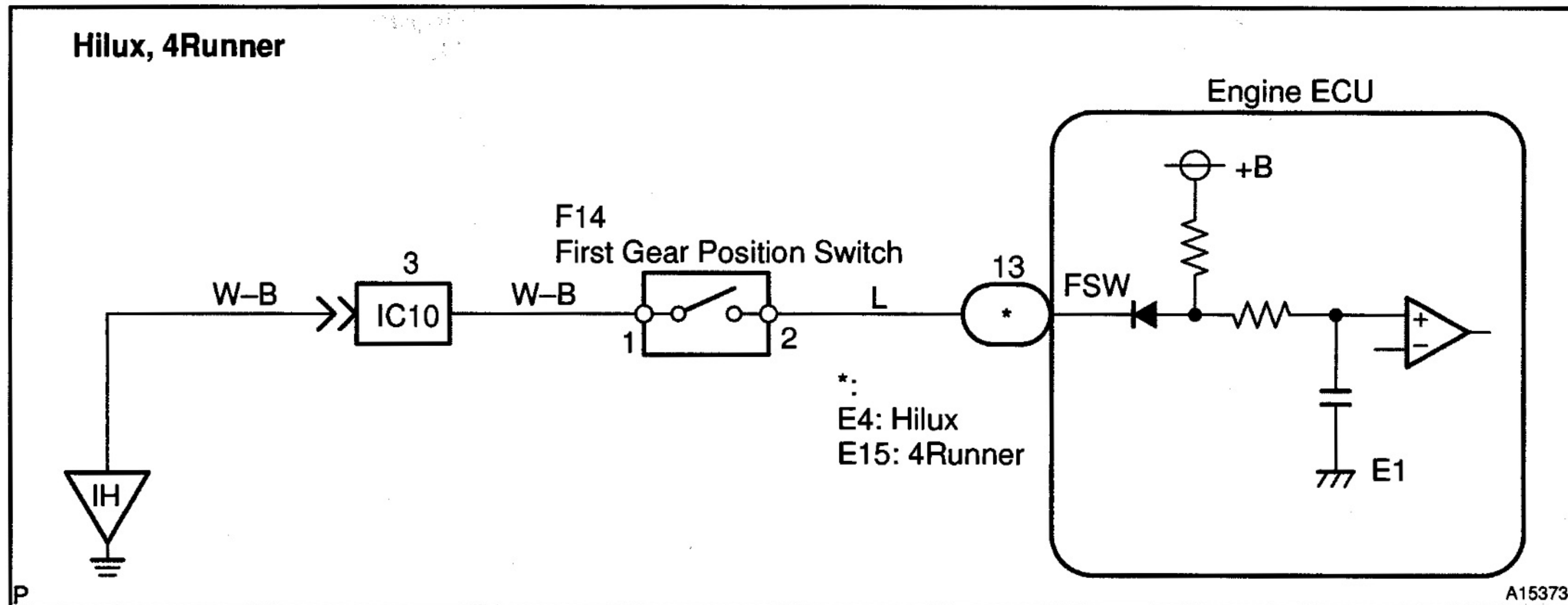

INSPECTION PROCEDURE

1	Check shift position switch (See page ED-21).
---	---

NG	Replace shift position switch.
----	--------------------------------

OK

2 Check voltage between terminal FSW of engine ECU connector and body ground.

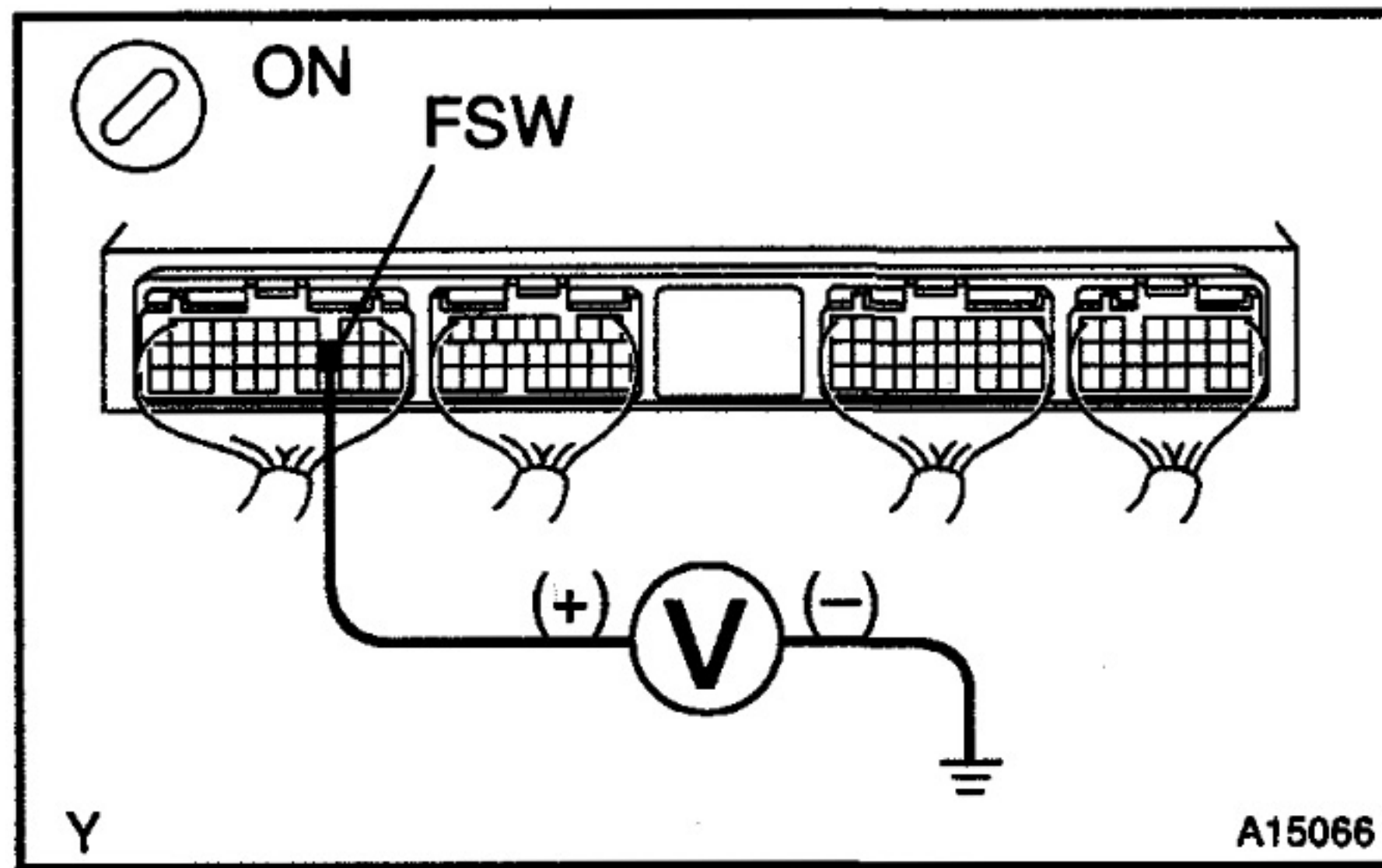

PREPARATION:

- (a) Remove the glove compartment door.
- (b) Turn the ignition switch ON.

CHECK:

Measure the voltage between terminal FSW of the engine ECU connector and the body ground after the shift lever is moved into the following positions.

OK:

Shift Lever Position	1st Gear	Except 1st Gear
Voltage	9 - 14 V	0 - 3 V

OK

Check and replace engine ECU (See page IN-20).

NG

Check for open and short in harness and connector between shift position switch and engine ECU (See page IN-20).

A/C Signal Circuit

CIRCUIT DESCRIPTION

When the A/C compressor is on, the A/C amplifier sends an A/C signal to the engine ECU, then engine ECU increases the fuel injection volume to improve the driveability during the engine idling.

WIRING DIAGRAM

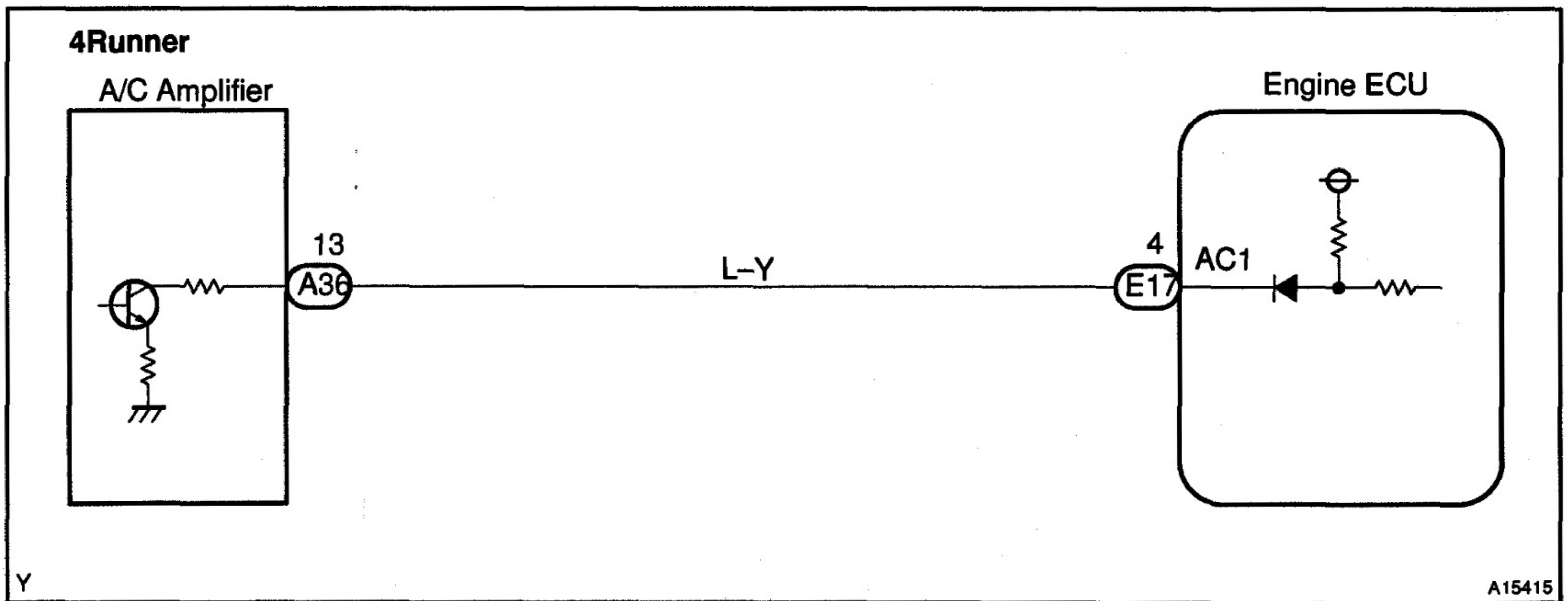
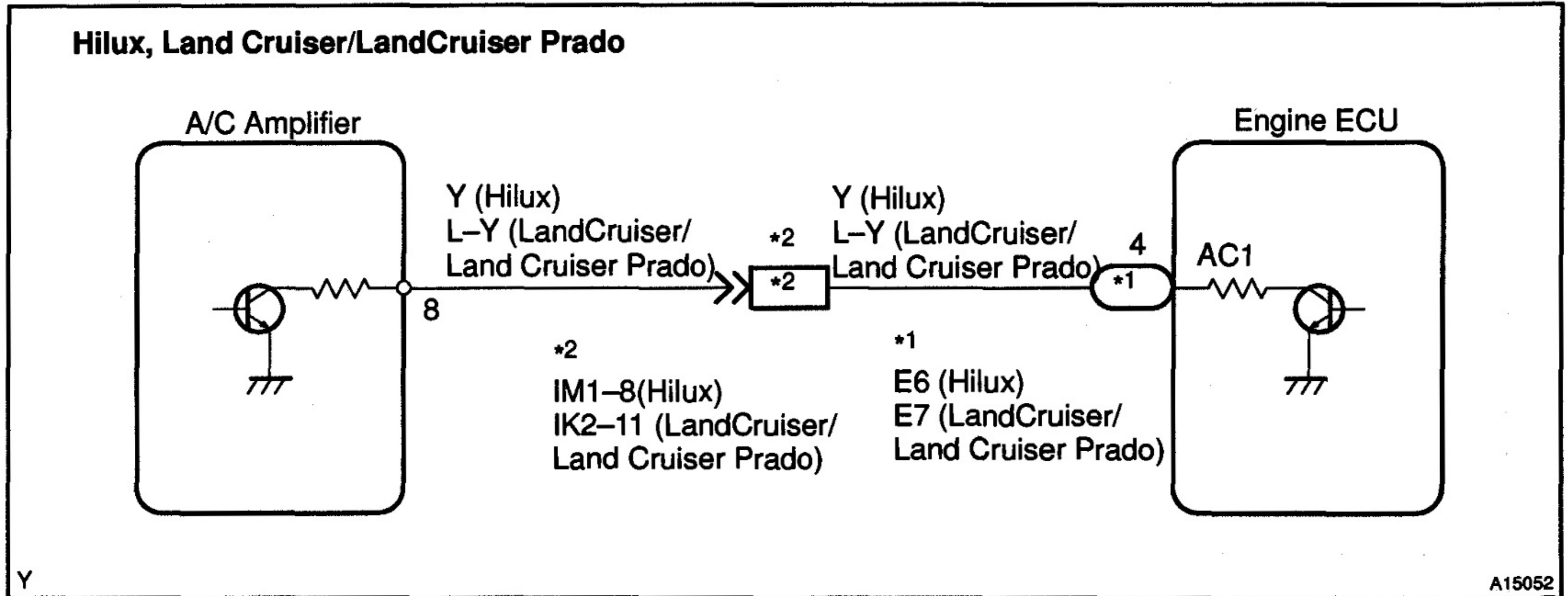

INSPECTION PROCEDURE

When using hand-held tester:

1	Connect hand-held tester, and check A/C signal.
----------	--

PREPARATION:

- (a) Connect the hand-held tester to the DLC3.
- (b) Turn the ignition switch ON and push the hand-held tester main switch ON.

CHECK:

Read the A/C signal on the hand-held tester while the A/C compressor is on.

OK:

A/C Switch Condition	OFF	ON
A/C Signal	OFF	ON

OK → Proceed to next circuit inspection shown on problem symptoms table (See page DI-24).

NG

2	Check voltage between terminal AC1 of engine ECU connector and body ground.
----------	--

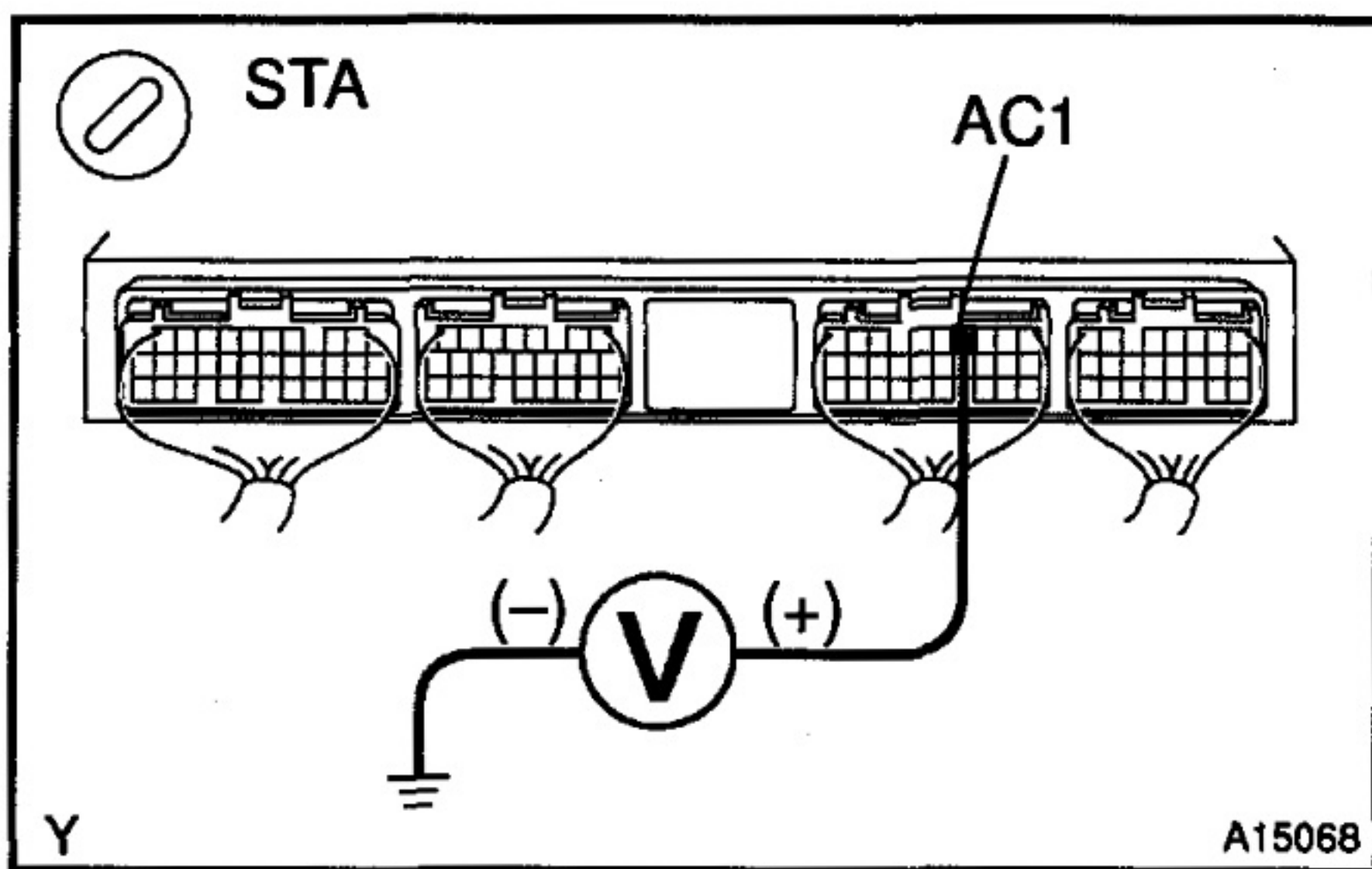

PREPARATION:

- (a) Remove the glove compartment door.
- (b) Start the engine.

CHECK:

Measure the voltage between terminal AC1 of the engine ECU connector and the body ground when the A/C switch is turned to ON and OFF.

OK:

A/C Switch Condition	Voltage
ON	Below 1.5 V
OFF	9 - 14 V

OK → Check and replace engine ECU (See page IN-20).

NG

3	Check for open and short in harness and connector between engine ECU and A/C amplifier (See page IN-20).
----------	---

NG → Repair or replace harness or connector.

OK

Check and replace A/C amplifier.

When not using hand-held tester:

1 Check voltage between terminal AC1 of engine ECU connector and body ground.

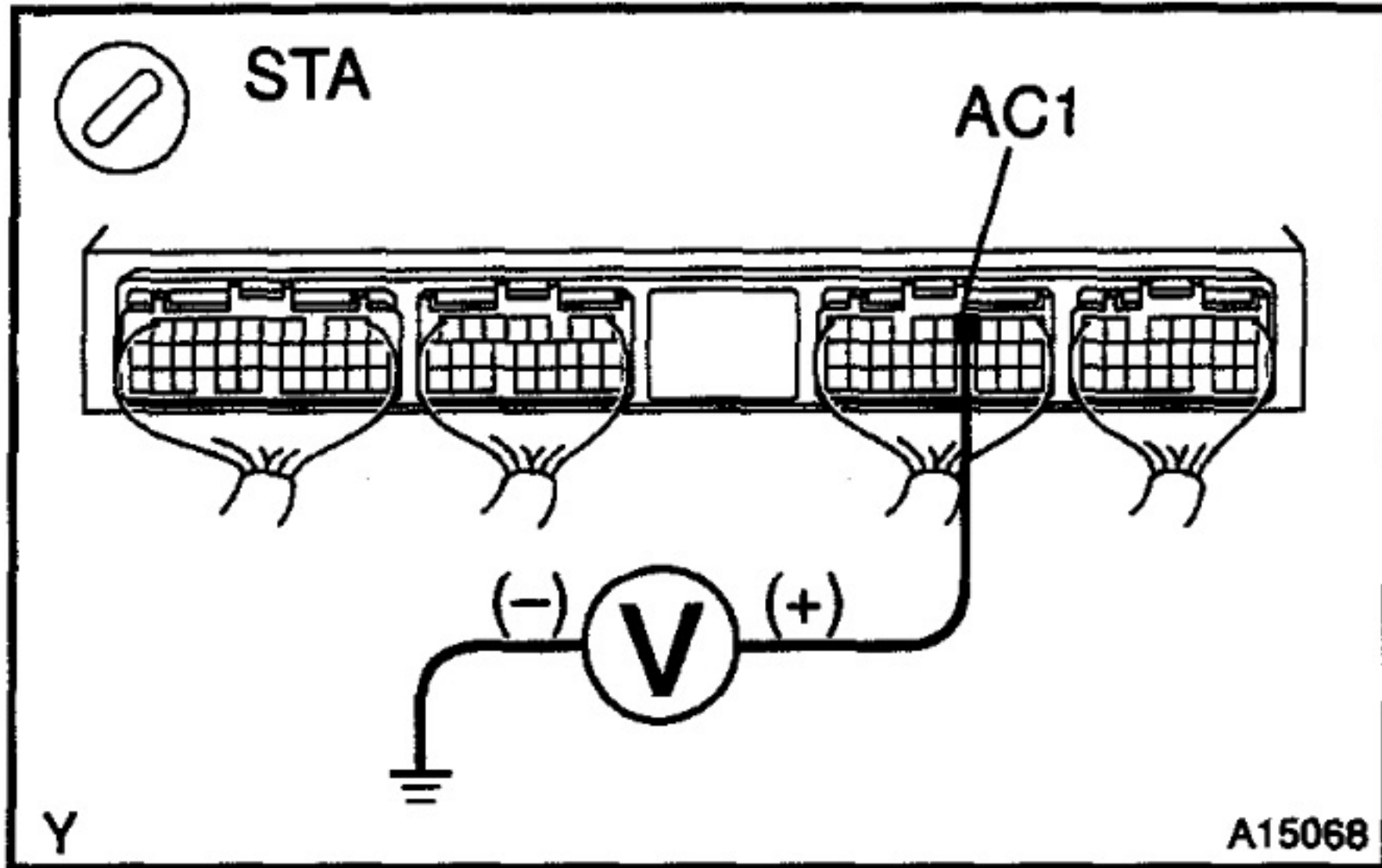

PREPARATION:

- (a) Remove the glove compartment door.
- (b) Start the engine.

CHECK:

Measure the voltage between terminal AC1 of the engine ECU connector and the body ground when the A/C switch is turned to ON and OFF.

OK:

A/C Switch Condition	Voltage
ON	Below 1.5 V
OFF	9 - 14 V

OK Proceed to next circuit inspection shown on problem symptoms table (See page DI-24).

NG

2 Check for open and short in harness and connector between engine ECU and A/C amplifier (See page IN-20).

NG Repair or replace harness or connector.

OK

Check and replace A/C amplifier.

A/C Cut Control Circuit

CIRCUIT DESCRIPTION

This circuit cuts the air conditioning operation during the vehicle acceleration in order to increase an acceleration performance. During the acceleration with the vehicle speed of 30 km/h (19 mph) or less and accelerator pedal opening angle of 45° or more, the A/C magnetic switch is turned off for several seconds.

The air conditioning is also controlled by the ECU outputting the engine coolant temperature to the A/C amplifier.

WIRING DIAGRAM

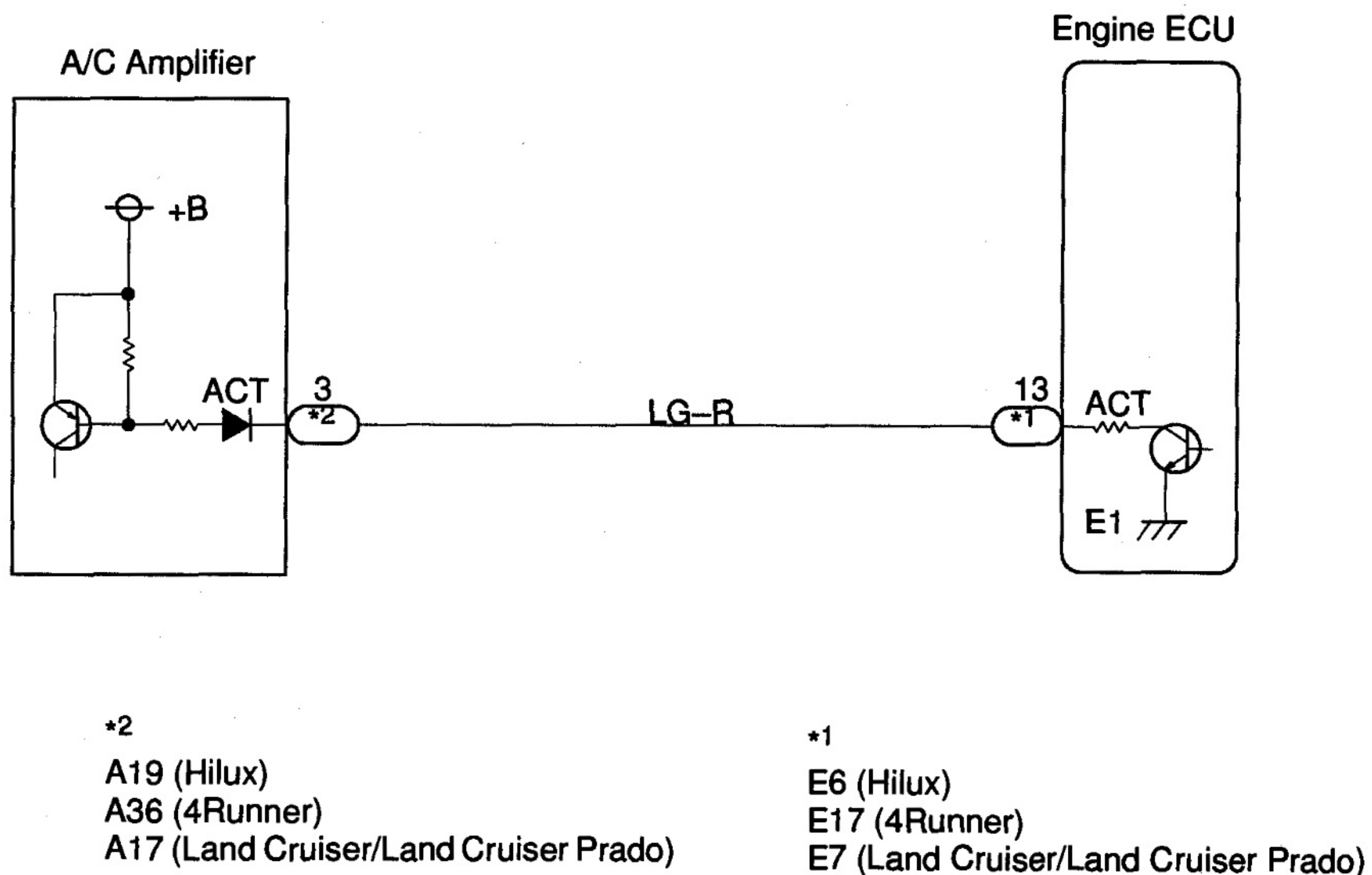

INSPECTION PROCEDURE**When using hand-held tester:**

1	Connect hand-held tester, and check operation of air conditioning cut control.
----------	---

PREPARATION:

- (a) Connect the hand held tester to the DLC3.
- (b) Turn the ignition switch ON and push the hand-held tester main switch ON.
- (c) Start the engine and turn the A/C switch ON.

HINT:

A/C magnetic clutch is turned ON.

- (d) Select the ACTIVE TEST mode on the hand-held tester.

CHECK:

Check the operation of the A/C magnetic clutch cut when the A/C cut control is operated by the hand-held tester.

OK:

A/C magnet clutch is turned off.

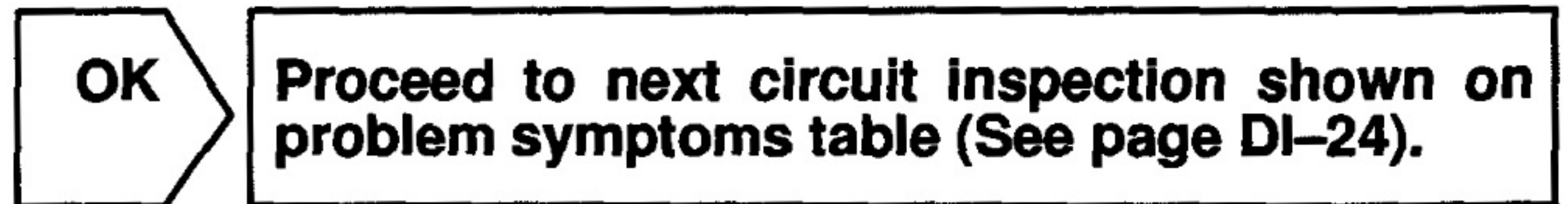

2	Check for open and short in harness and connector between engine ECU and A/C amplifier (See page IN-20).
----------	---

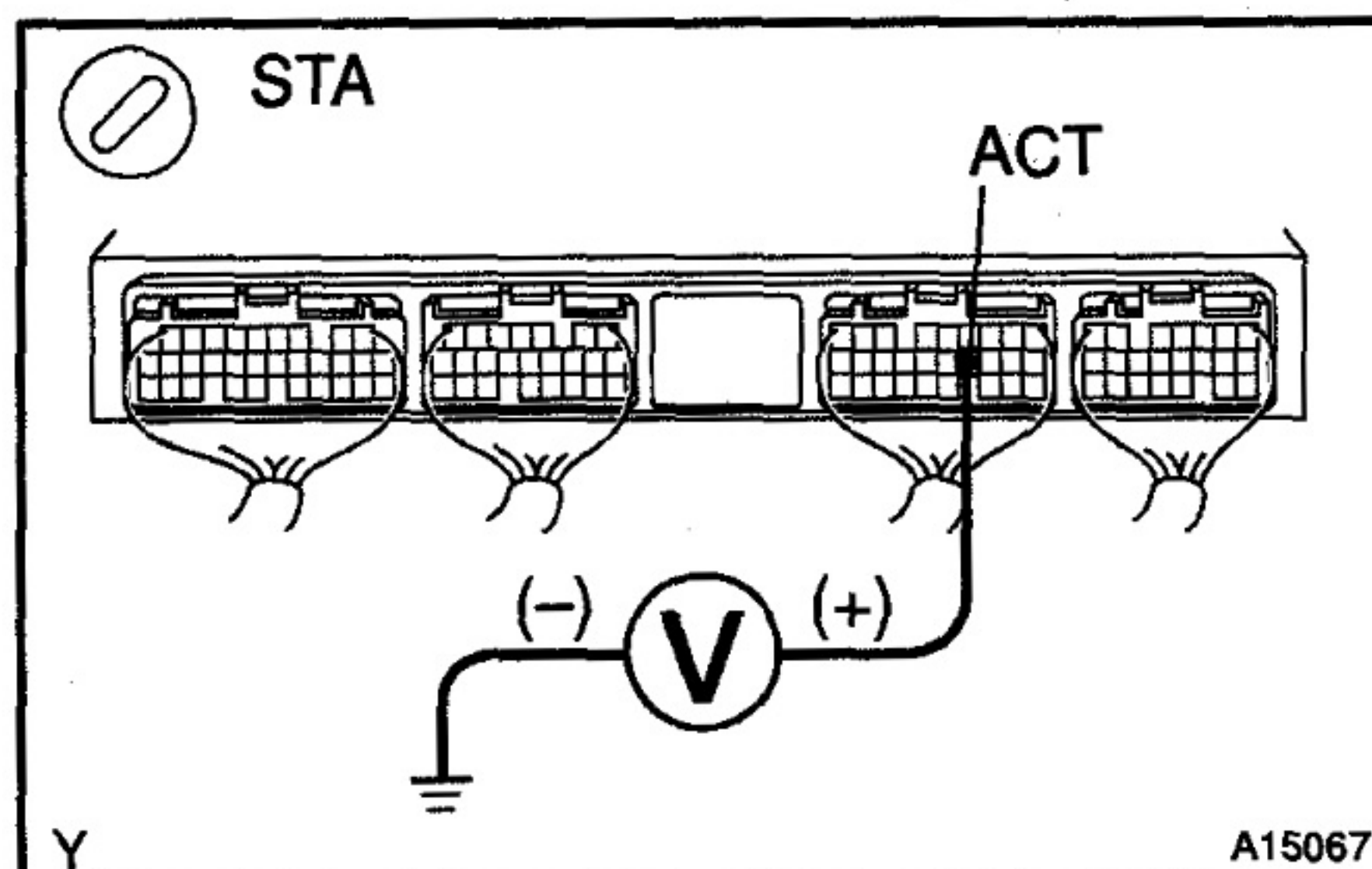

3	Check voltage between terminal ACT of engine ECU connector and body ground.
----------	--

**PREPARATION:**

- (a) Remove the glove compartment door.
- (b) Start the engine.

CHECK:

Measure the voltage between terminal ACT of the engine ECU connector and the body ground when the A/C switch is turned to ON and OFF.

OK:

A/C Switch Condition	Voltage
ON	9 - 14 V
OFF	0 - 3 V

NG**Check and replace A/C amplifier.****OK****Check and replace engine ECU (See page IN-20).****When not using hand-held tester:****1****Check voltage between terminal ACT of engine ECU connector and body ground (See page DI-128, step 3).****OK****Check and replace engine ECU (See page IN-20).****NG****2****Check for open and short in harness and connector between engine ECU and A/C amplifier (See page IN-20).****NG****Repair or replace harness or connector.****OK****Check and replace A/C amplifier.**

ENGINE MECHANICAL

IDLE SPEED AND MAXIMUM SPEED	EM-1
CYLINDER HEAD	EM-2
CYLINDER BLOCK	EM-8

REFER TO FOLLOWING REPAIR MANUALS:

Manual Name	Pub. No.
1KZ-T Engine Repair Manual	RM353E
1KZ-TE Engine Repair Manual	RM710E
1KZ-T, 1KZ-TE Engine Repair Manual Supplement	RM522E

EM

NOTE: The above pages contain only the points which differ from the above listed manuals.

IDLE SPEED AND MAXIMUM SPEED INSPECTION

EMOOL-03

1. INITIAL CONDITIONS

- (a) Engine at normal operating temperature.
- (b) Air cleaner installed.
- (c) All pipes and hoses of air induction system connected.
- (d) All accessories switched OFF.
- (e) All vacuum lines properly connected.
- (f) ECD system warning connectors fully plugged.
- (g) Valve clearance set correctly.
- (h) Ignition timing check correctly.

EM

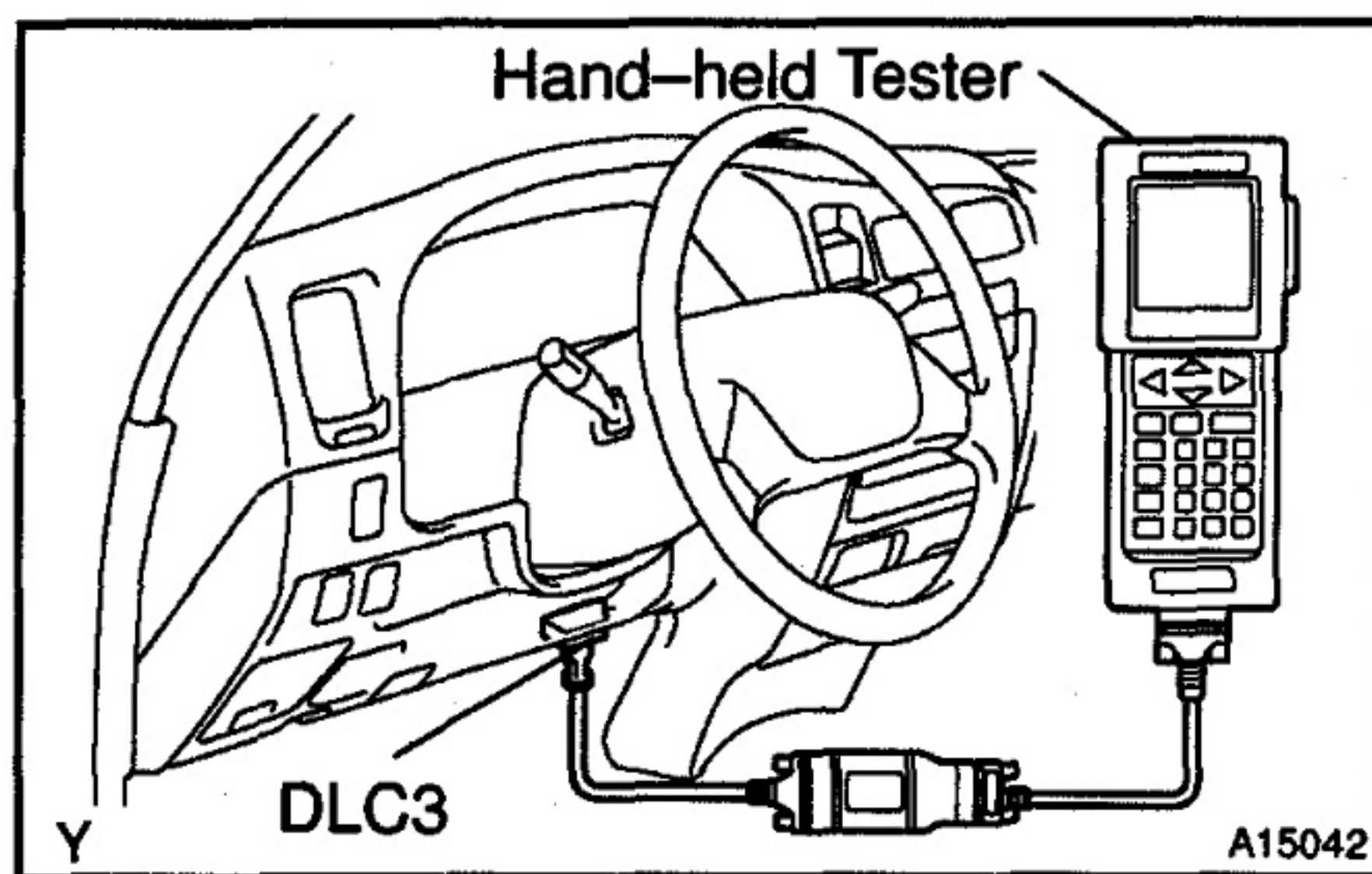

2. CONNECT HAND-HELD TESTER

- (a) Connect a hand-held tester to the DLC3.
- (b) Please refer to the hand-held tester operator's manual for further details.

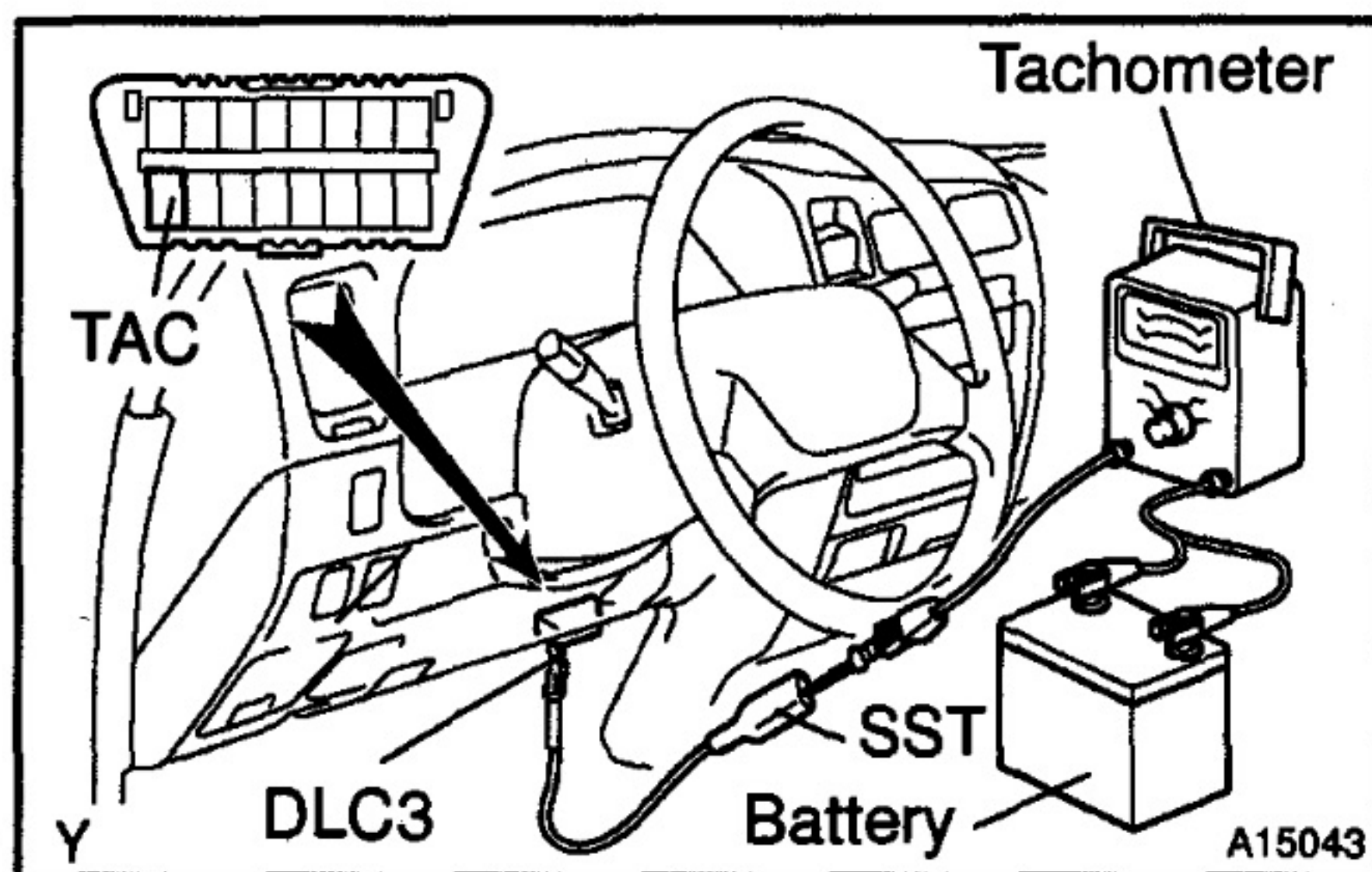

If you have no hand-held tester, connect a tachometer tester probe to terminal TAC of the DLC3 with SST.

SST 09843-18040

3. INSPECT IDLE SPEED

- (a) Start the engine.
- (b) Check the idle speed.

Idle speed: 650 – 750 rpm

4. INSPECT MAXIMUM SPEED

- (a) Start the engine.
- (b) Depress the accelerator pedal all the way.
- (c) Check the maximum speed.

Maximum speed: 4,450 – 4,750 rpm

5. DISCONNECT HAND-HELD TESTER

CYLINDER HEAD COMPONENTS

EM1LQ-01

w/ Intercooler (Land Cruiser/Land Cruiser Prado for Australia)

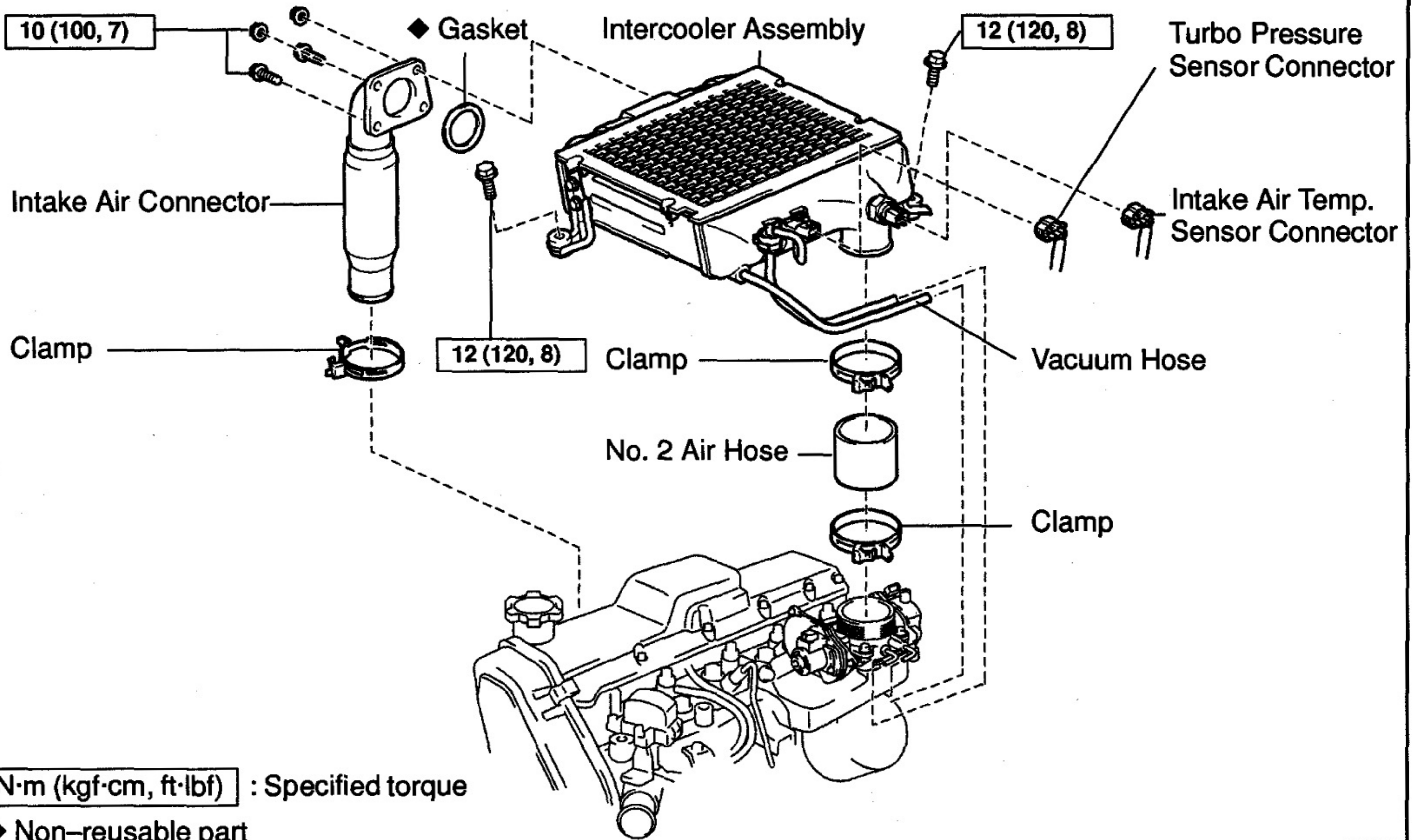

B13244

EM

w/o Intercooler

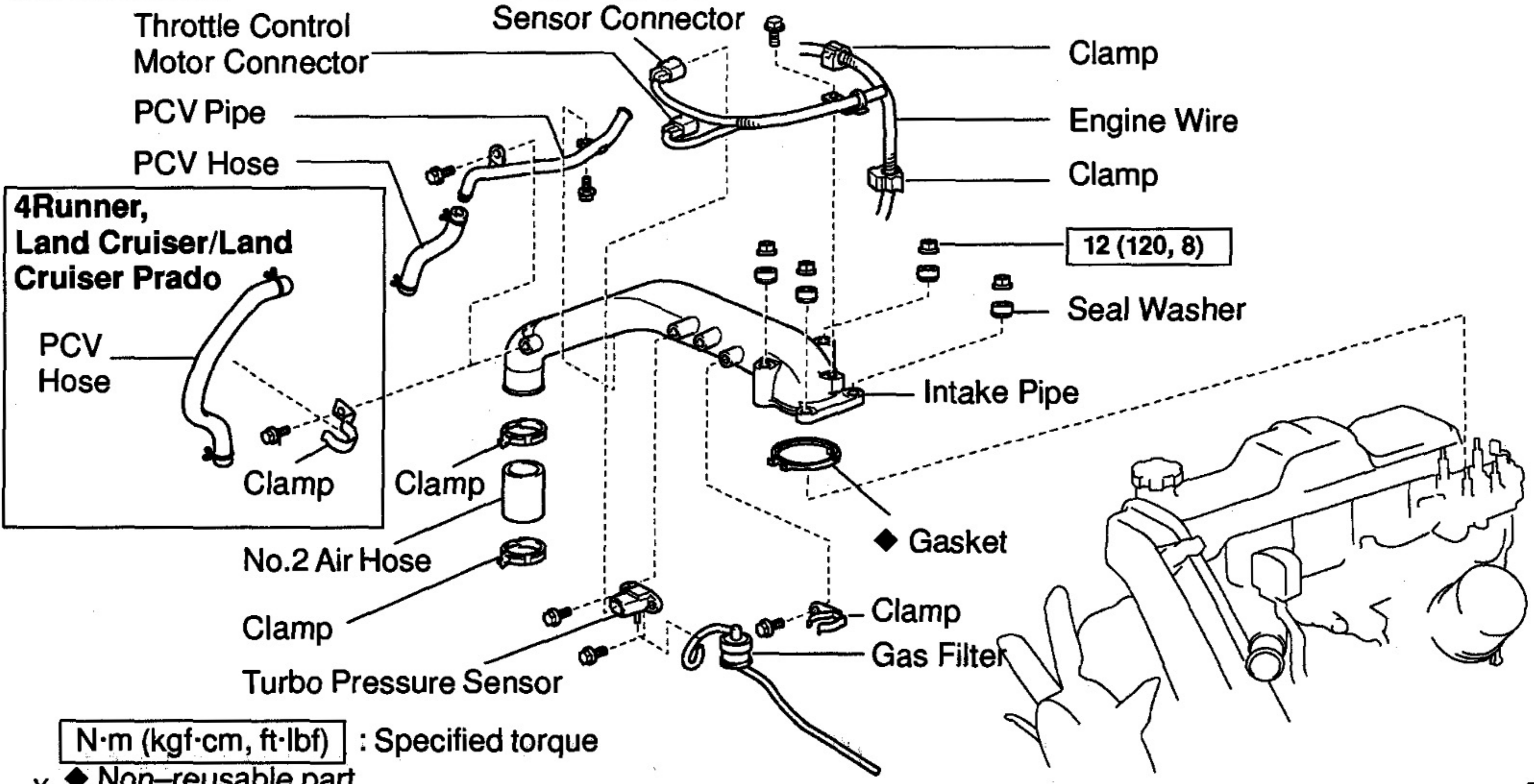

B13243

EM

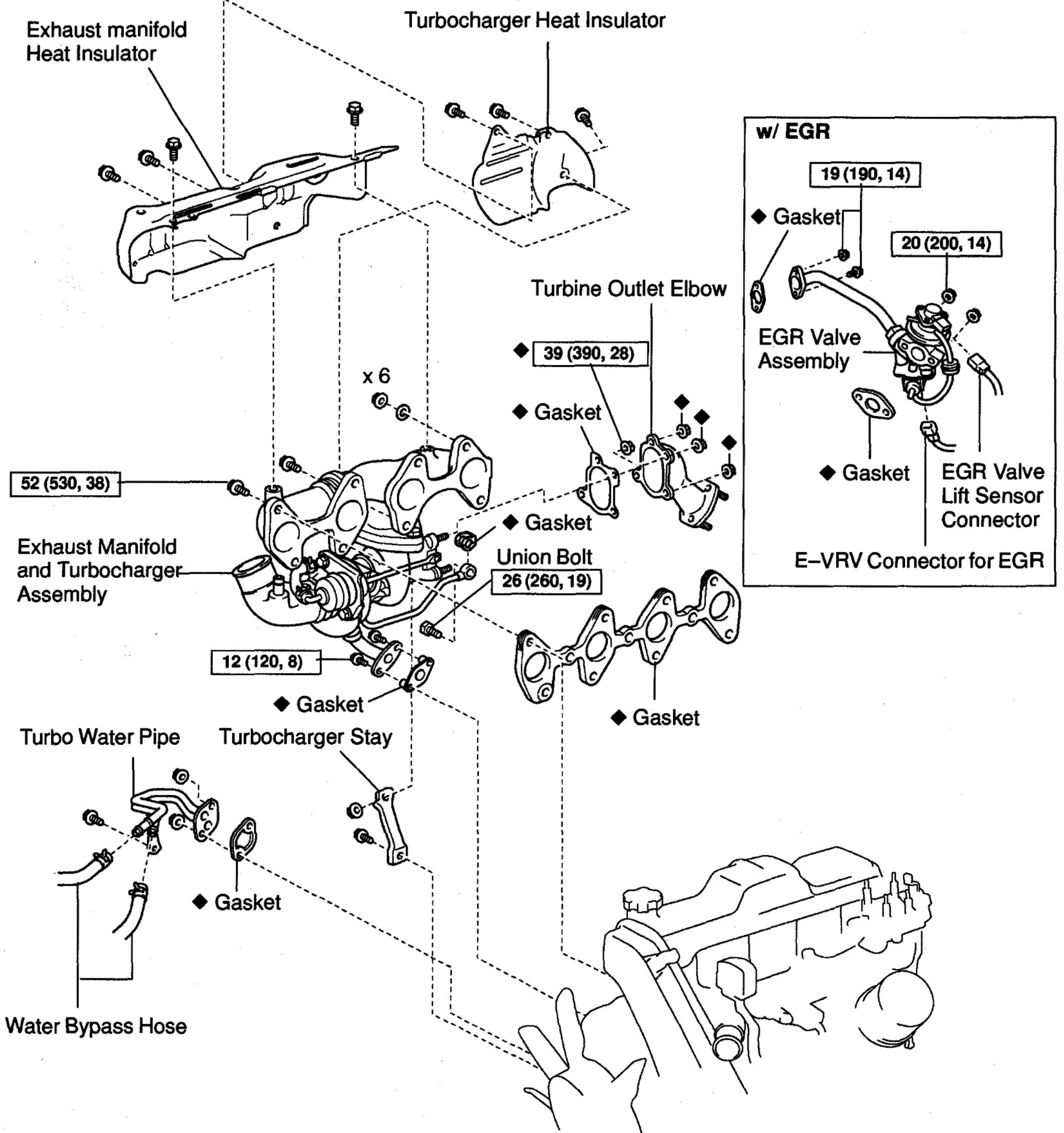

N·m (kgf·cm, ft·lbf) : Specified torque

◆ Non-reusable part

EM

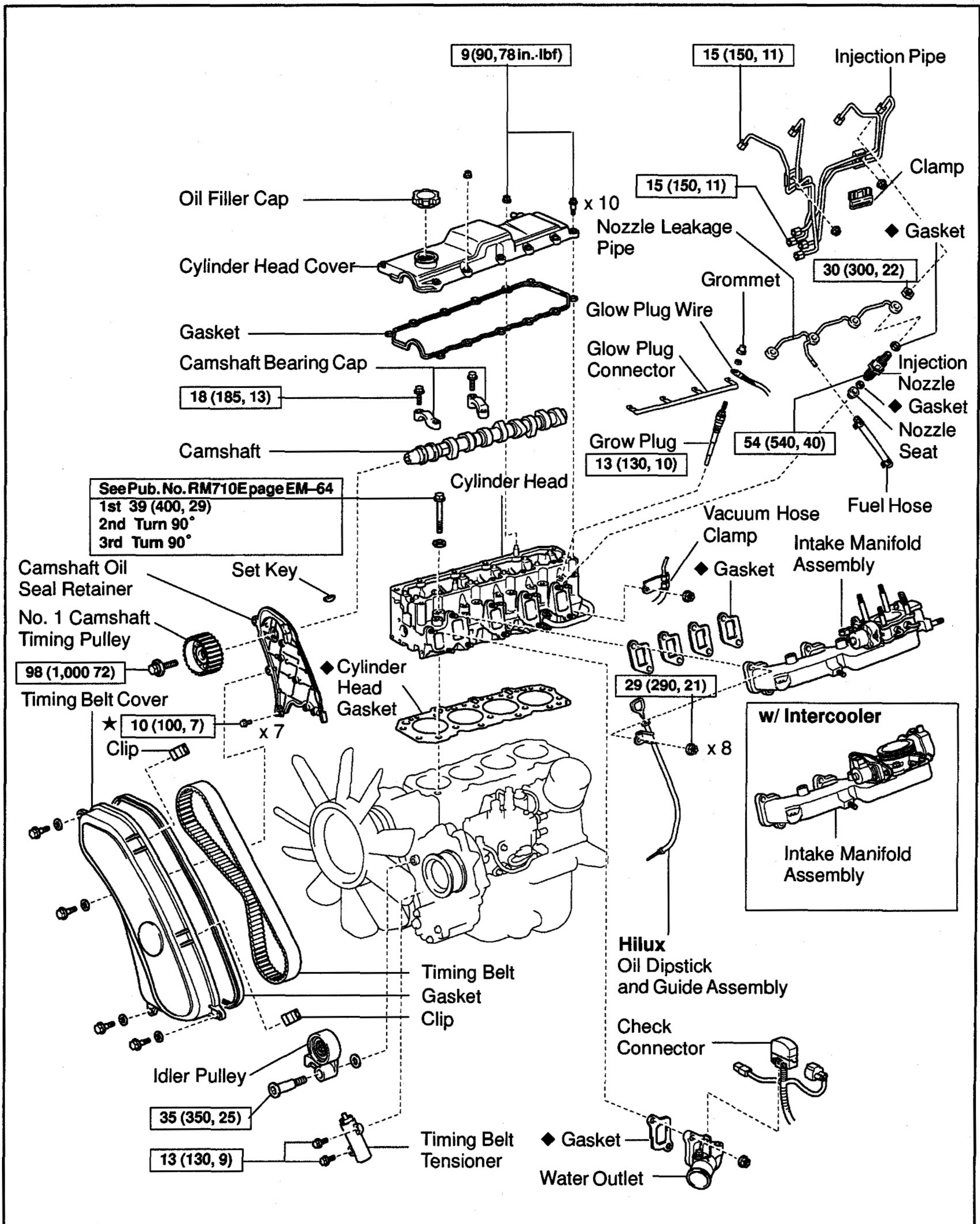

See Pub. No. RM710E page EM-64
 1st 39 (400, 29)
 2nd Turn 90°
 3rd Turn 90°

N·m (kgf·cm, ft·lbf) : Specified torque
 ◆ Non-reusable part
 ★ Precoated part

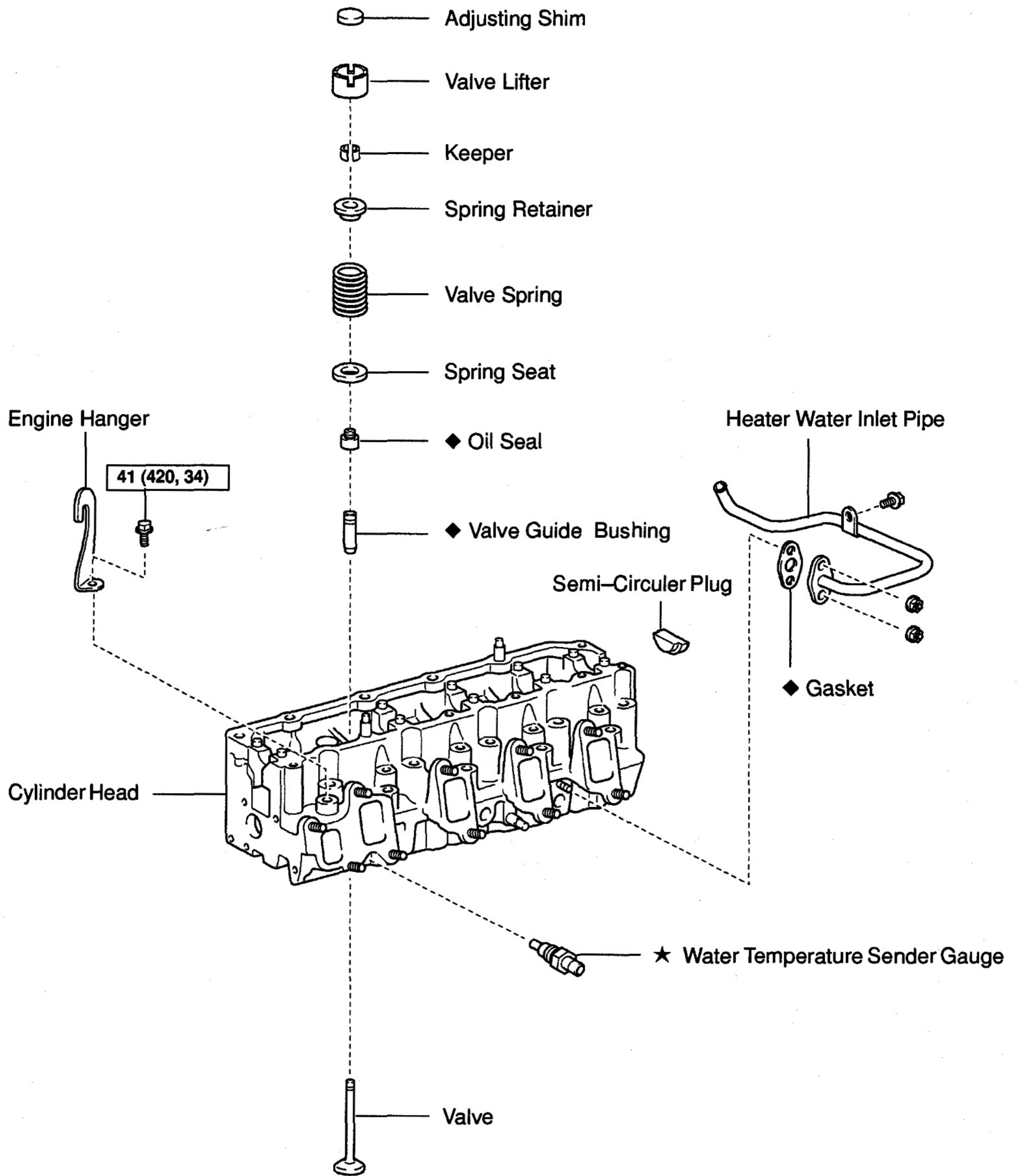

N·m (kgf·cm, ft·lbf) : Specified torque

◆ Non-reusable part

★ Precoated part

Y

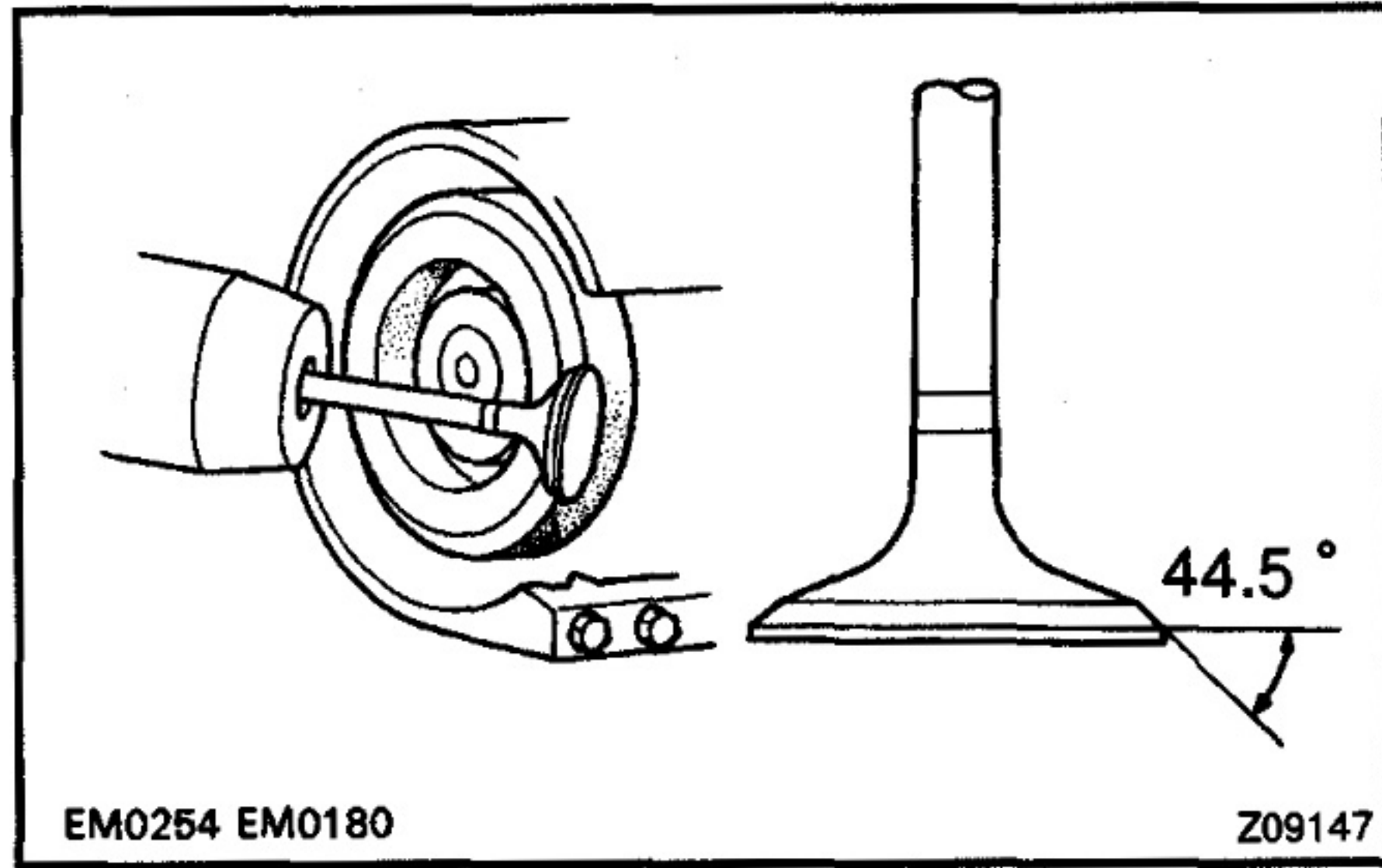

INSPECTION

1. INSPECT AND GRIND VALVES

- (a) Grind the valve enough to remove pits and carbon.
- (b) Check that the valve is ground to the correct valve face angle.

Valve face angle: 44.5°

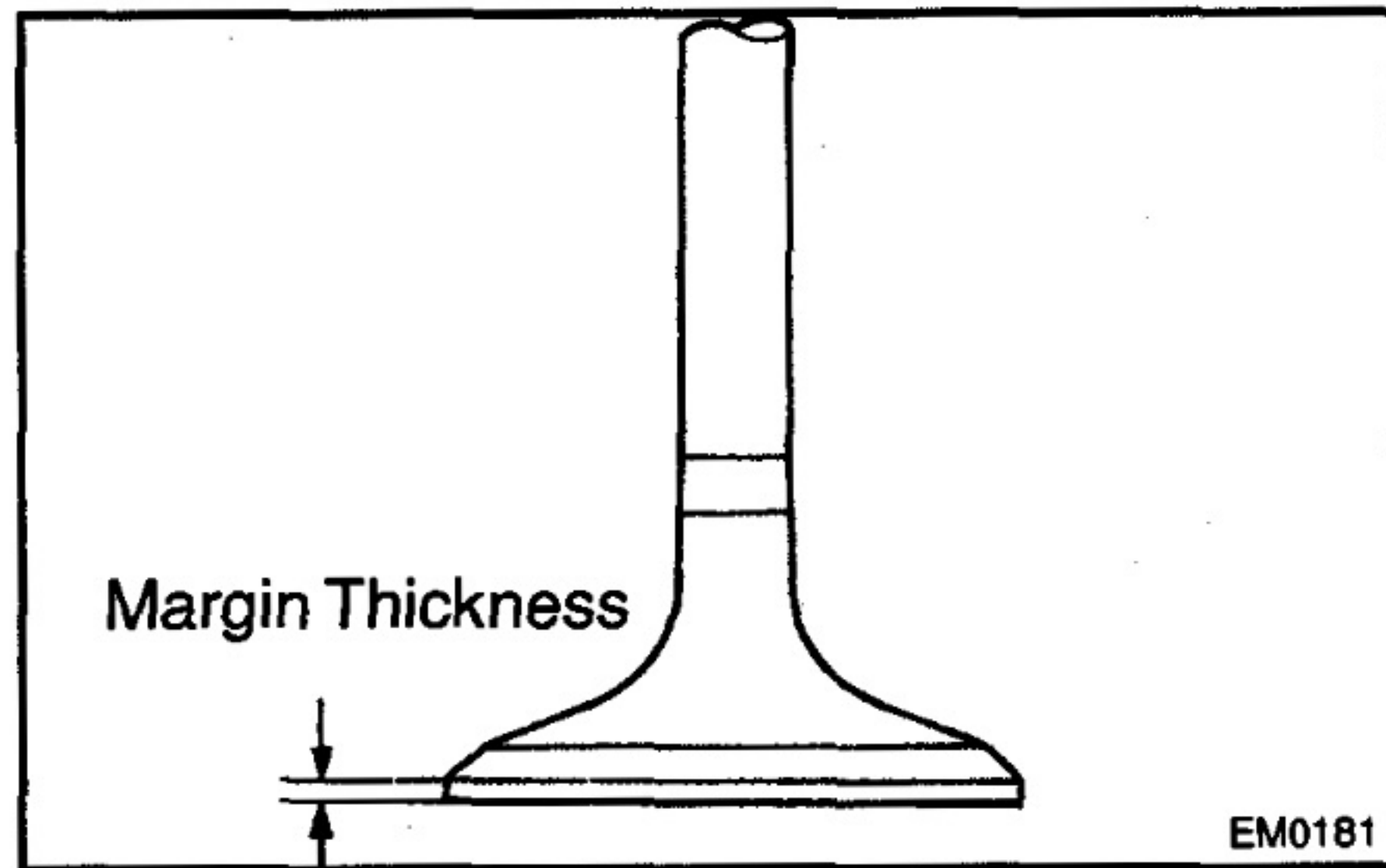

- (c) Check the valve head margin thickness.

Standard margin thickness:

Intake	1.6 mm (0.063 in.)
Exhaust	1.7 mm (0.067 in.)

Minimum margin thickness:

Intake	1.1 mm (0.043 in.)
Exhaust	1.2 mm (0.047 in.)

If the margin thickness is less than minimum, replace the valve.

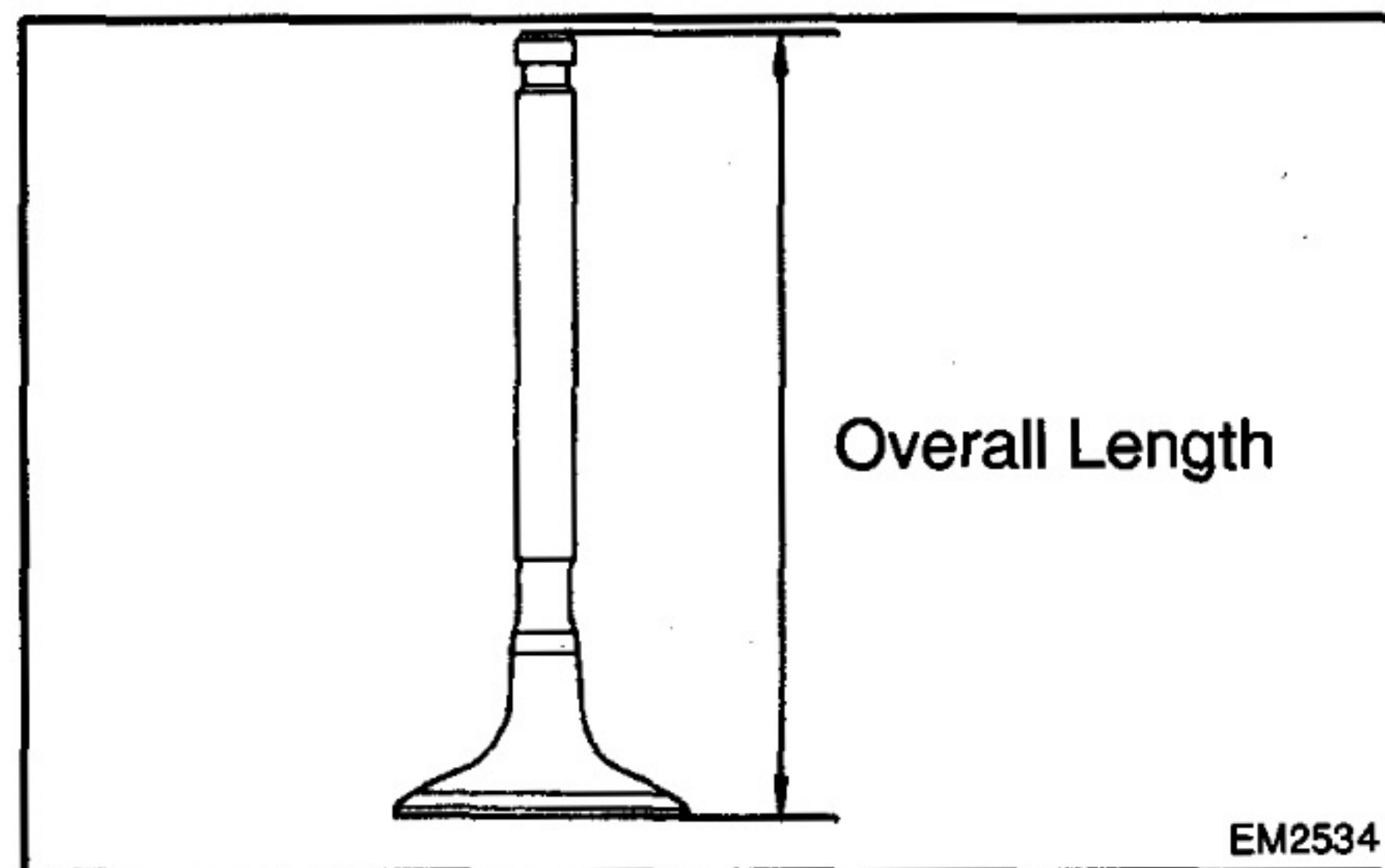

- (d) Check the valve overall length.

Standard overall length:

104.10 – 104.50 mm (4.0984 – 4.1142 in.)

Minimum overall length: 103.60 mm (4.0787 in.)

If the overall length is less than minimum, replace the valve.

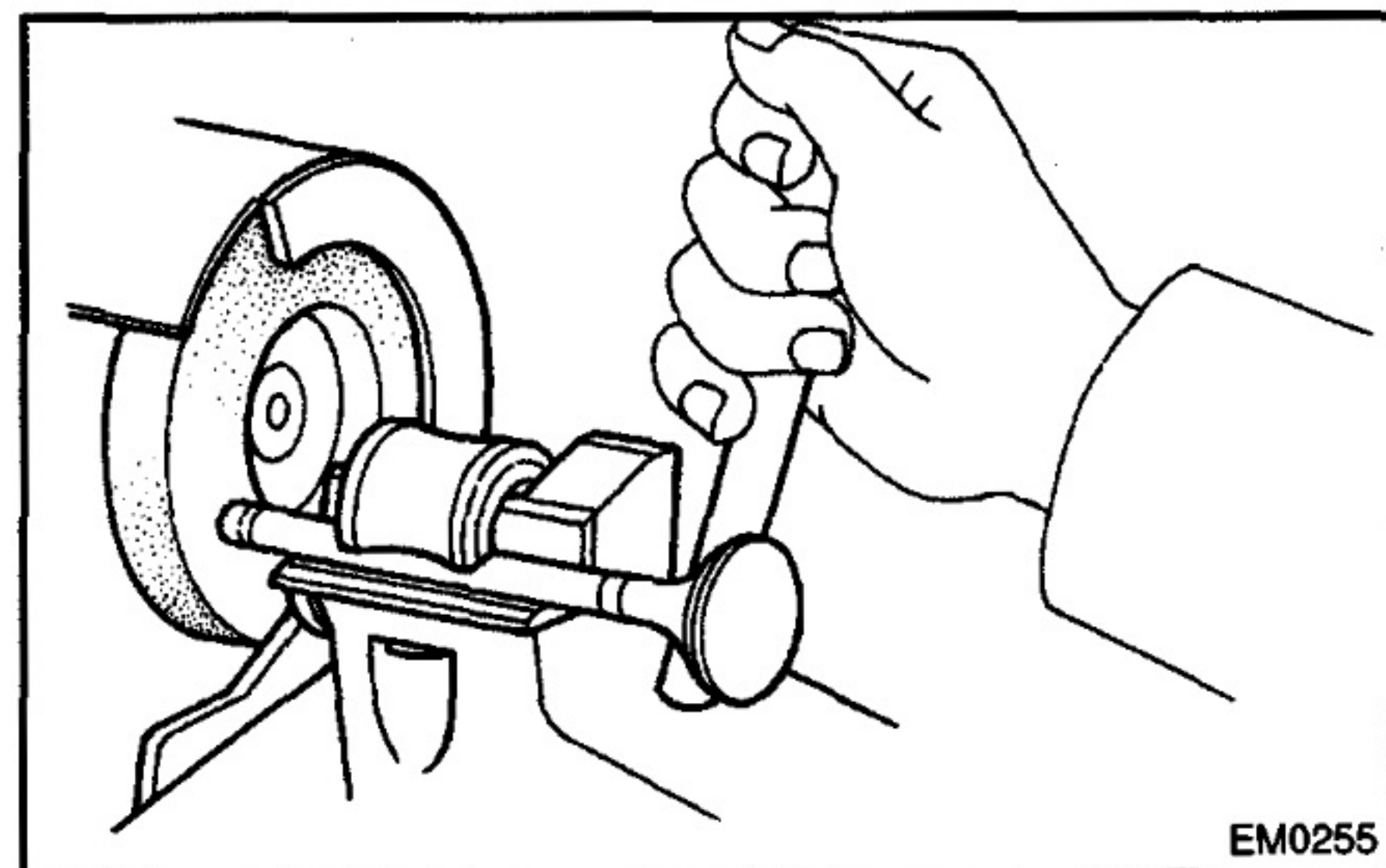

- (e) Check the surface of the valve stem tip for wear.

If the valve stem tip is worn, resurface the tip with a grinder or replace the valve.

NOTICE:

Do not grind off more than minimum overall length.

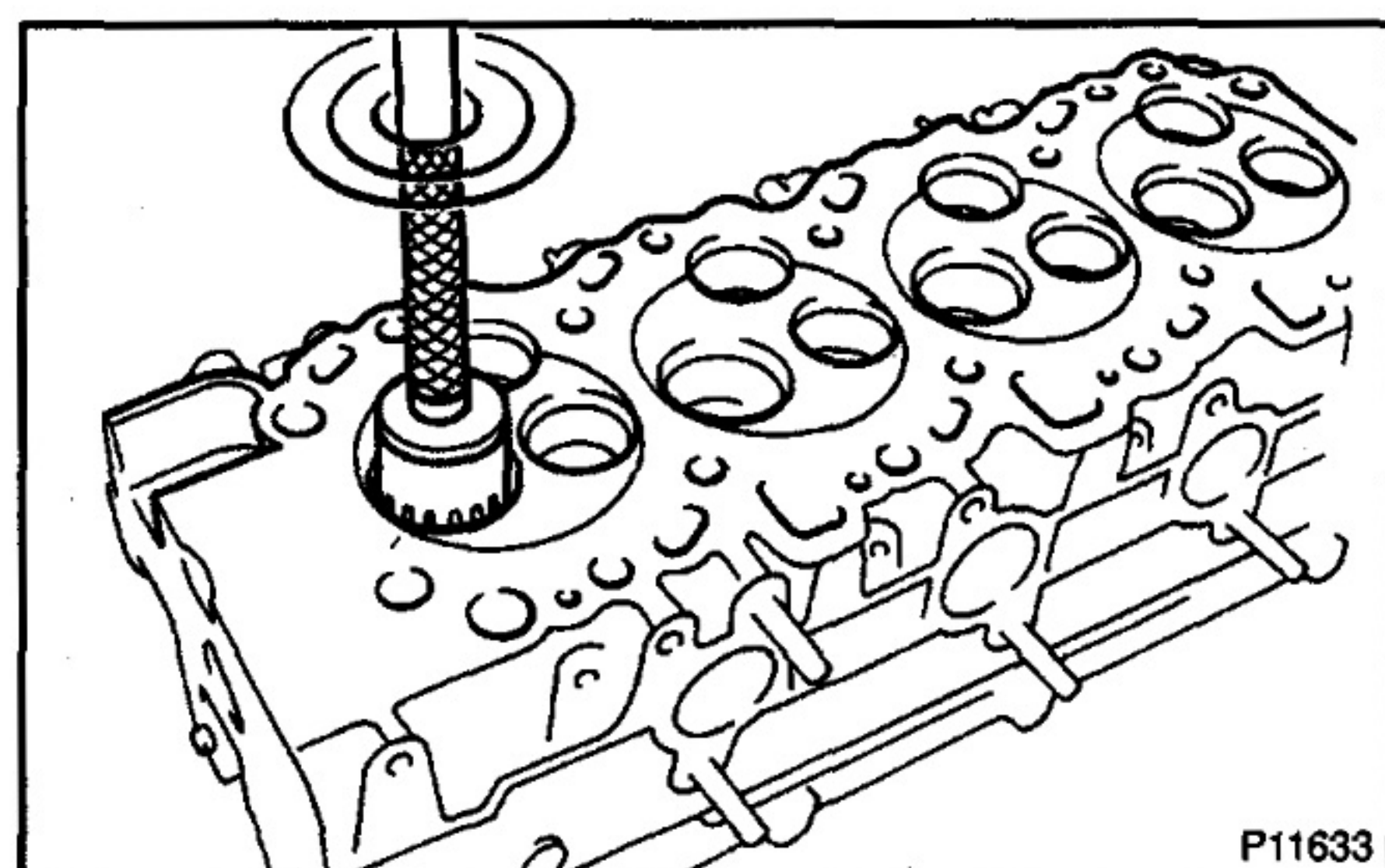

2. INSPECT AND CLEAN VALVE SEATS

- (a) Using a 45° carbide cutter, resurface the valve seats. Remove only enough metal to clean the seats.

EM

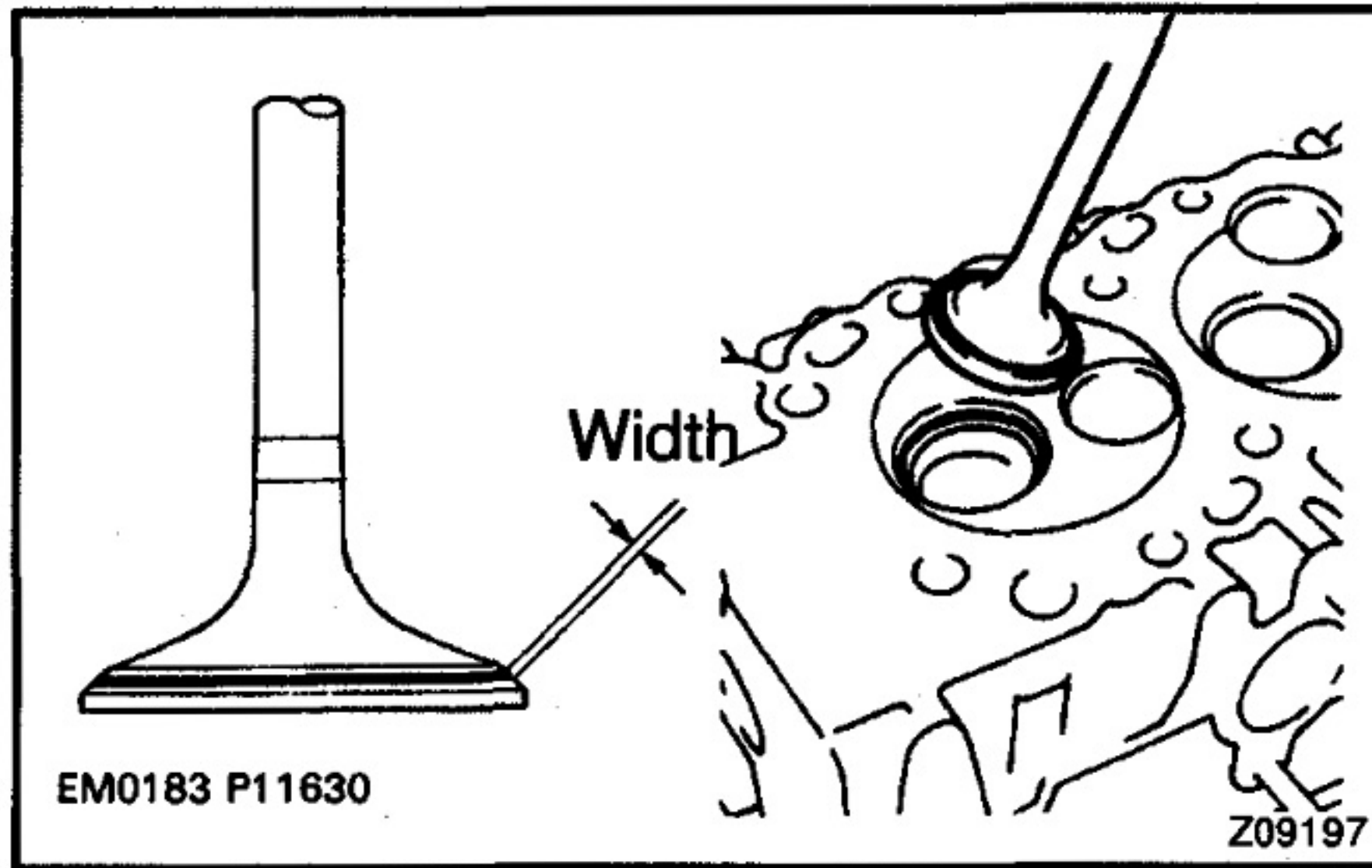

- (b) Check the valve seating position.
Apply a light coat of prussian blue (or white lead) to the valve face. Lightly press the valve against the seat. Do not rotate valve.
- (c) Check the valve face and seat for the following:
- If blue appears 360° around the valve face, the valve is concentric. If not, replace the valve.
 - If blue appears 360° around the valve seat, the guide and face are concentric. If not, resurface the seat.
 - Check that the seat contact is in the middle of the valve face with the following width:

Intake	1.5 – 1.9 mm (0.059 – 0.075 in.)
Exhaust	1.8 – 2.2 mm (0.071 – 0.087 in.)

EM

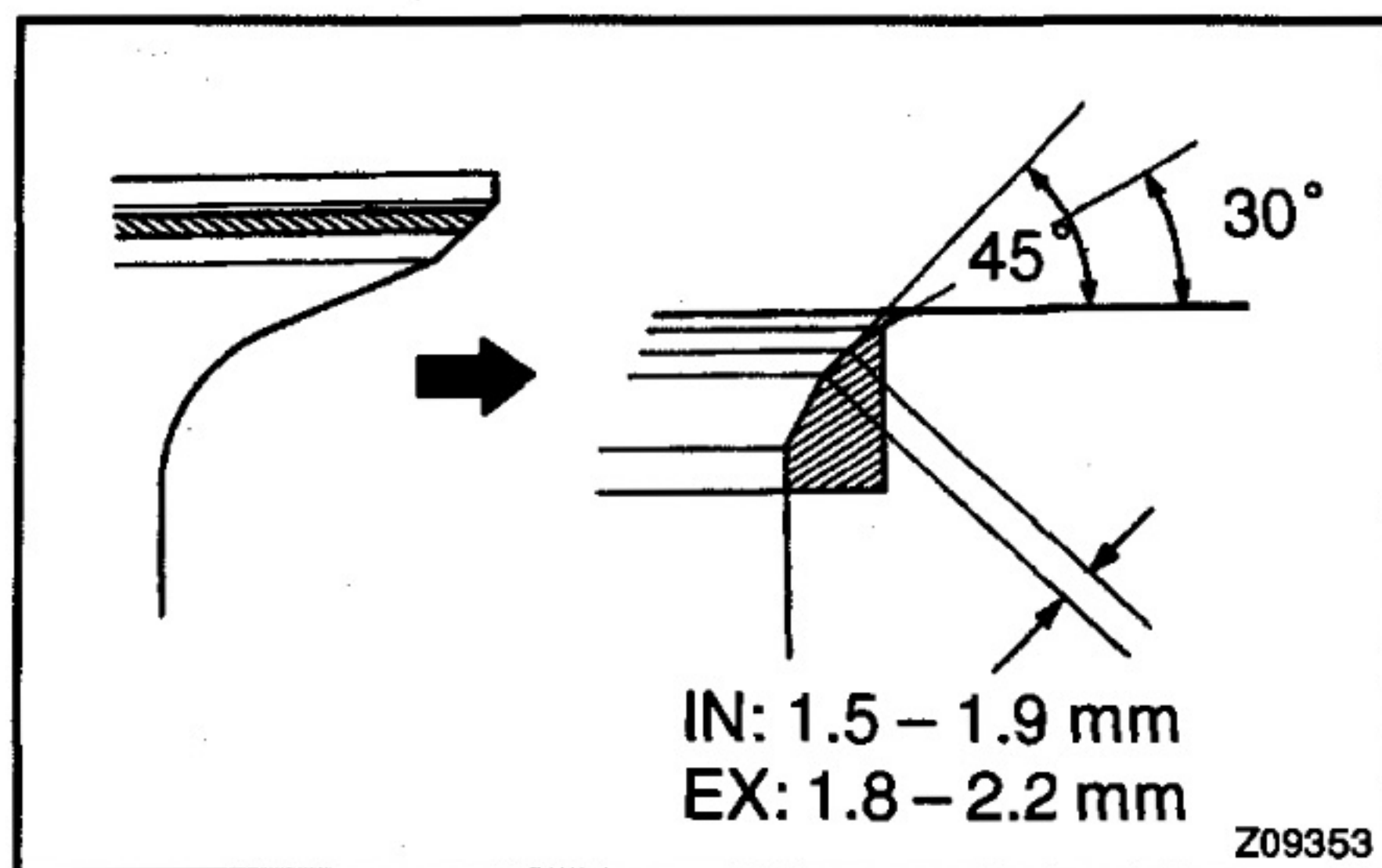

If not, correct the valve seats as follows:

- (1) If the seating is too high on the valve face, use 30° and 45° cutters to correct the seat.

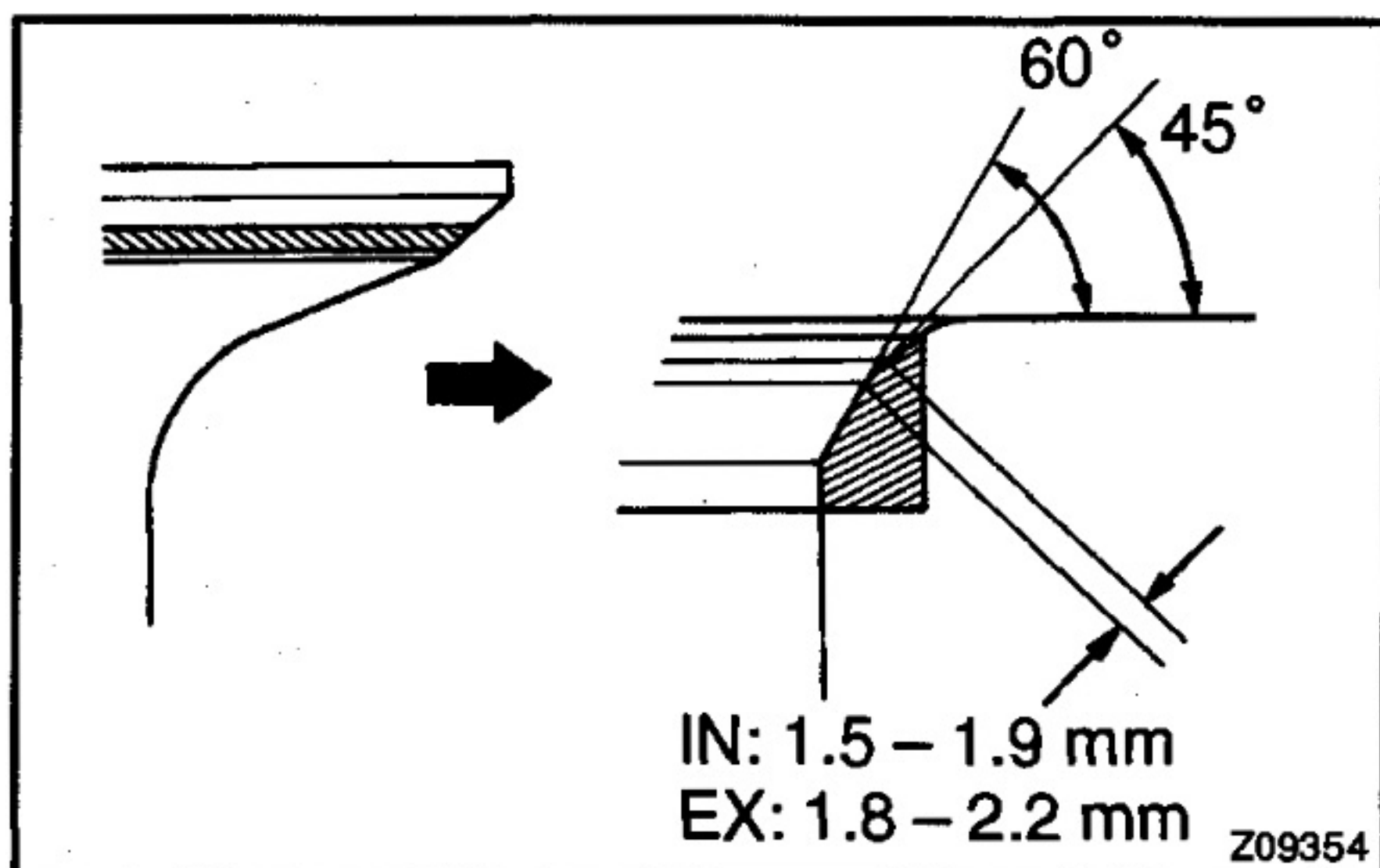

- (2) If the seating is too low on the valve face, use 60° and 45° cutters to correct the seat.

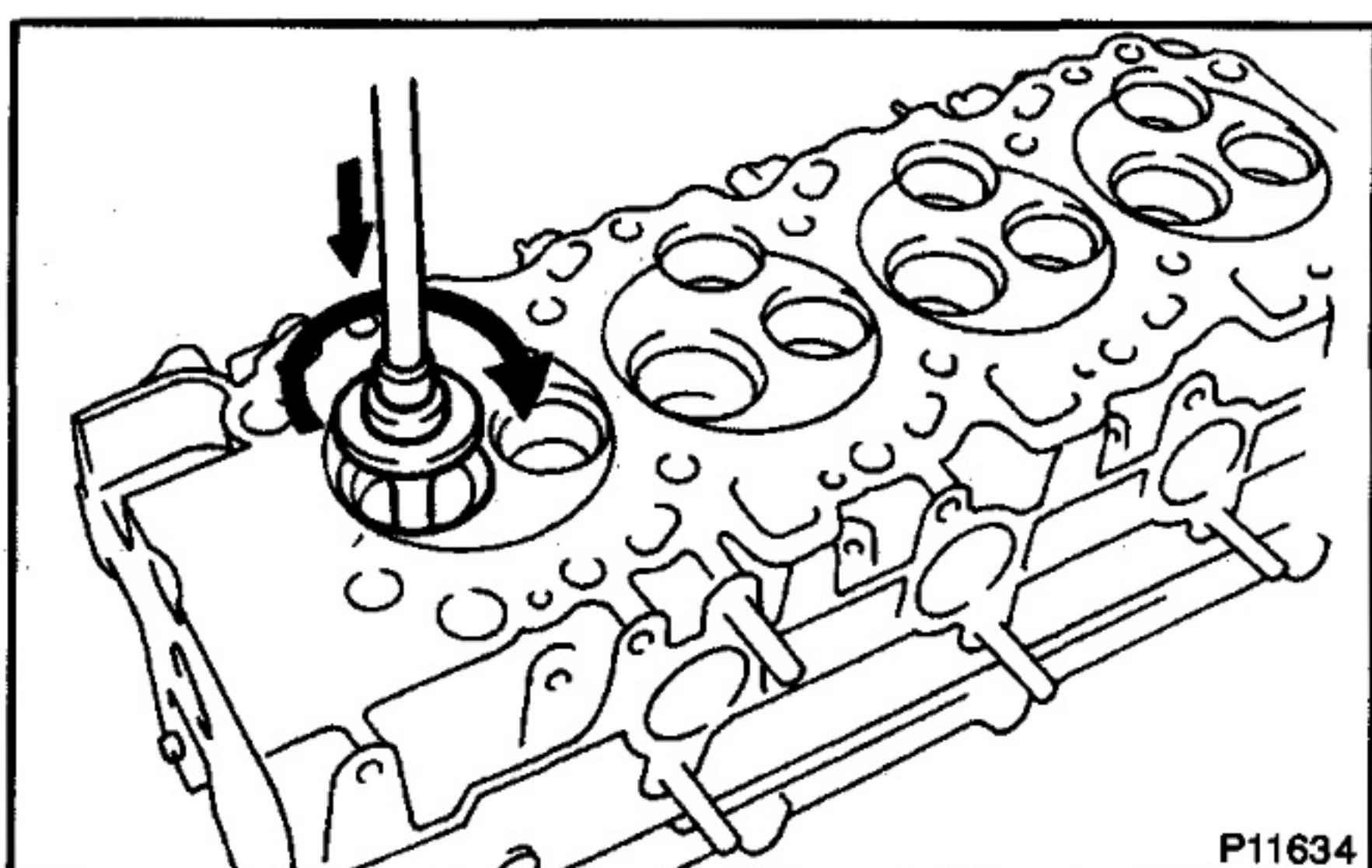

- (d) Hand-lap the valve and valve seat with an abrasive compound.
- (e) After hand-lapping, clean the valve and valve seat.
- (f) Remove the bearing caps.

CYLINDER BLOCK DISASSEMBLY

EM1LS-01

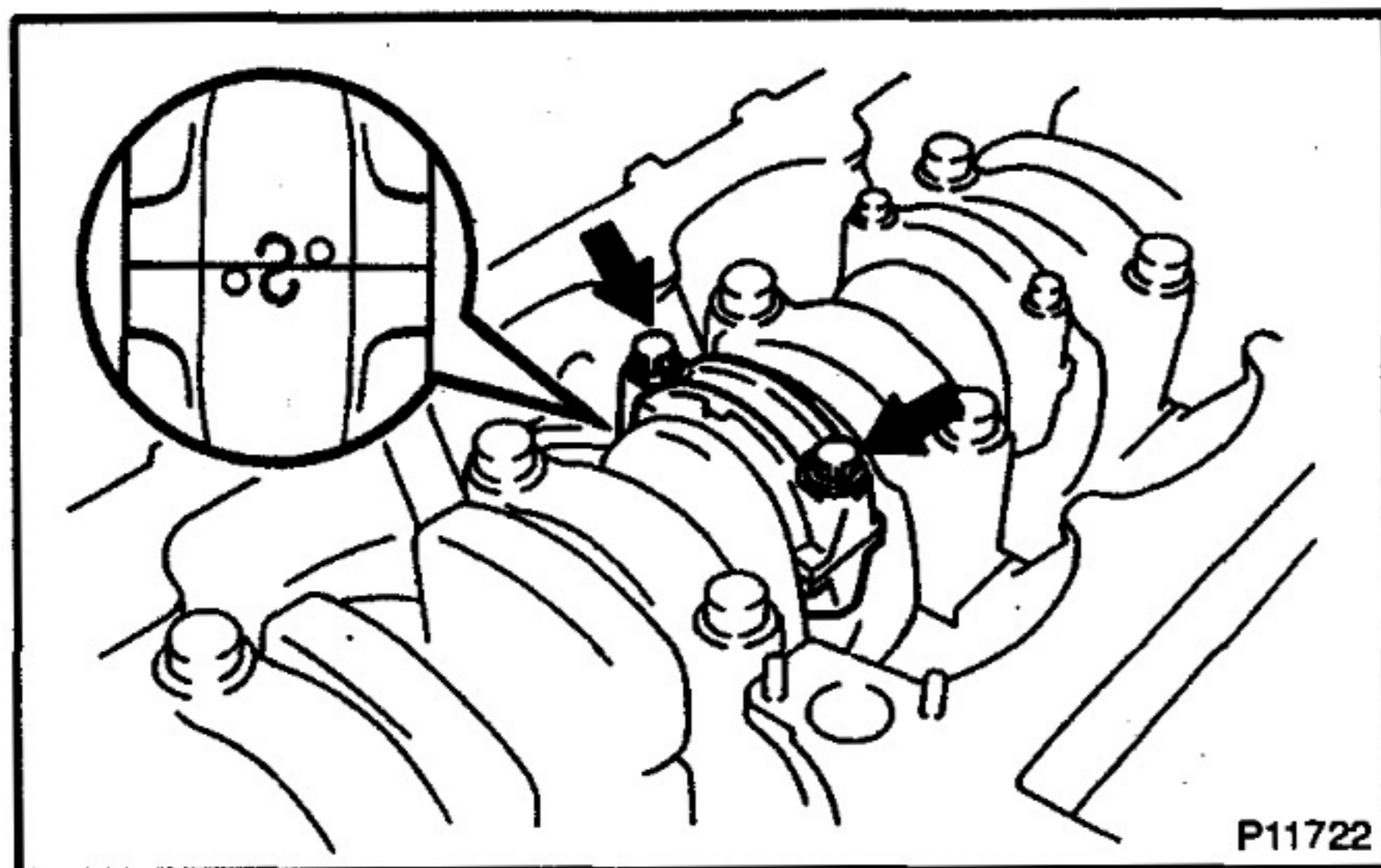

1. REMOVE CONNECTING ROD CAPS AND CHECK OIL CLEARANCE

- (a) Using a punch or numbering stamp, place matchmarks on the connecting rod and cap to ensure correct reassembly.
- (b) Remove the connecting rod cap bolts.

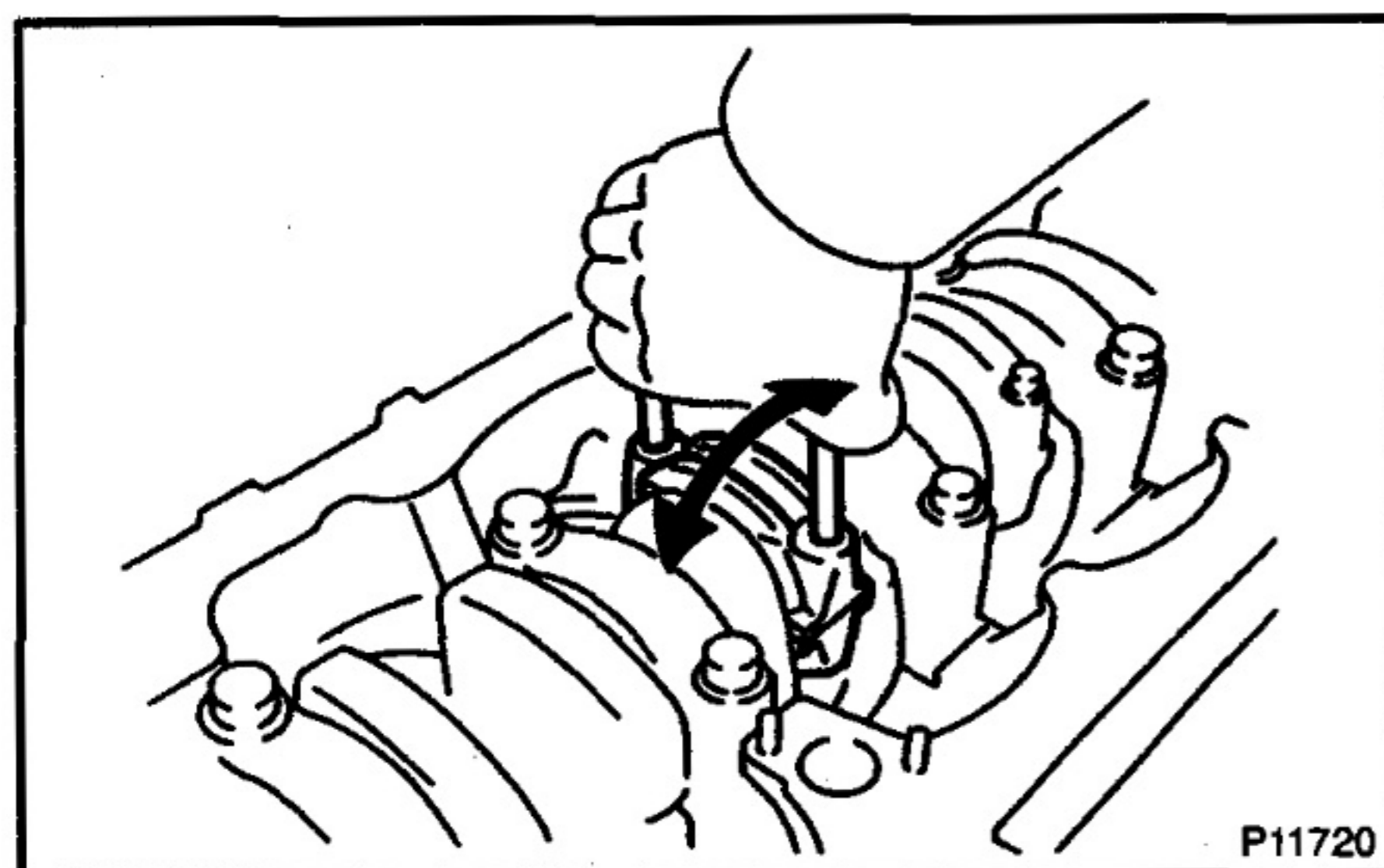

- (c) Using the 2 removed connecting rod bolts, pry the connecting rod cap back and forth, and remove the connecting cap.

HINT:

Keep the lower bearing inserted with the connecting rod cap.

- (d) Clean the crank pin and bearing.
- (e) Check the crank pin and bearing for pitting and scratches. If the crank pin or bearing is damaged, replace the bearings. If necessary, grind or replace the crankshaft.

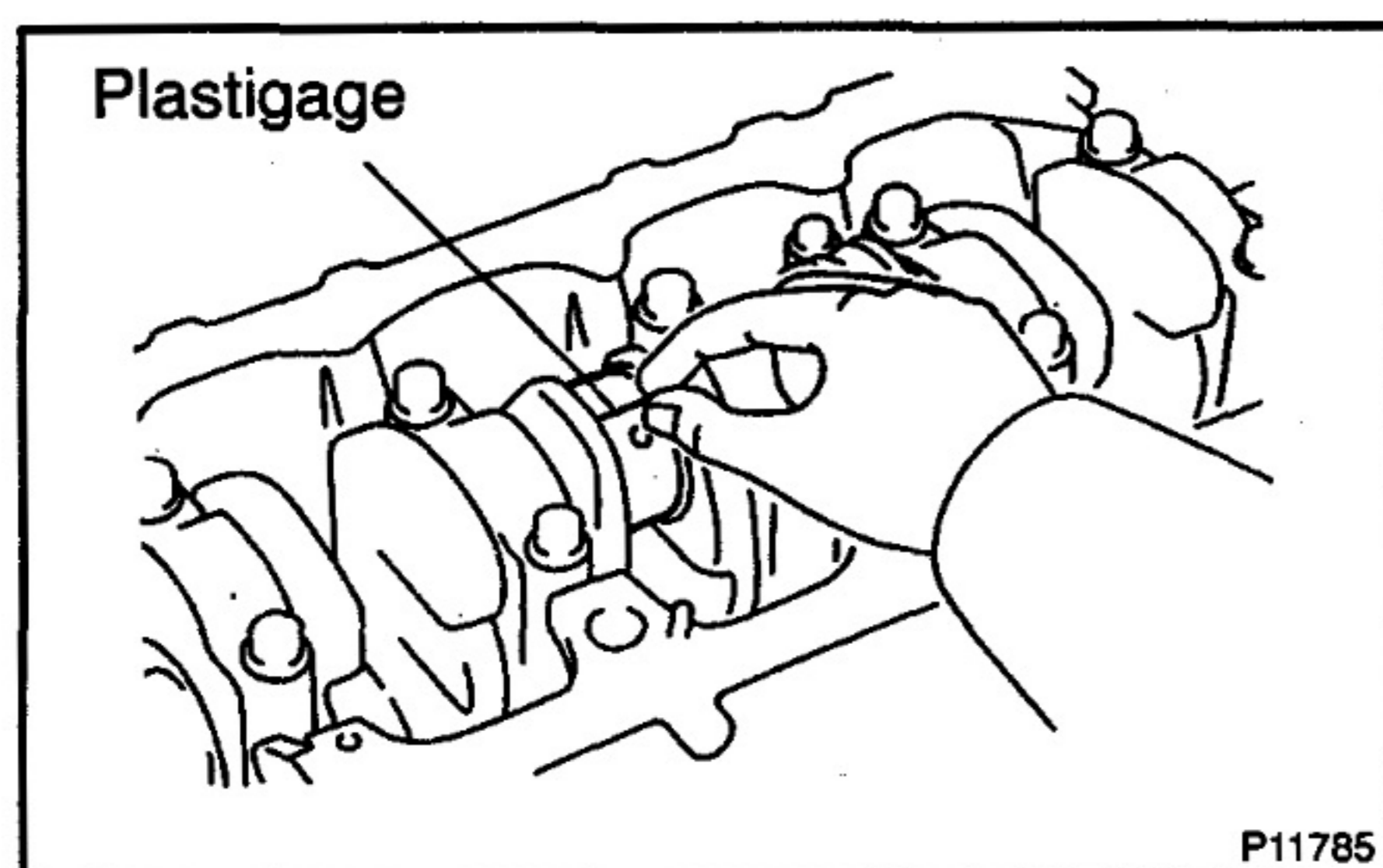

- (f) Lay a strip of Plastigage across the crank pin.
- (g) Install the connecting rod cap with the 2 bolts. (See Pub. No. RM710E, page EM-94)

Torque:

1st: 29.5 N·m (300 kgf·cm, 22 ft·lbf)

2nd: Turn 90°

NOTICE:

Do not turn the crankshaft.

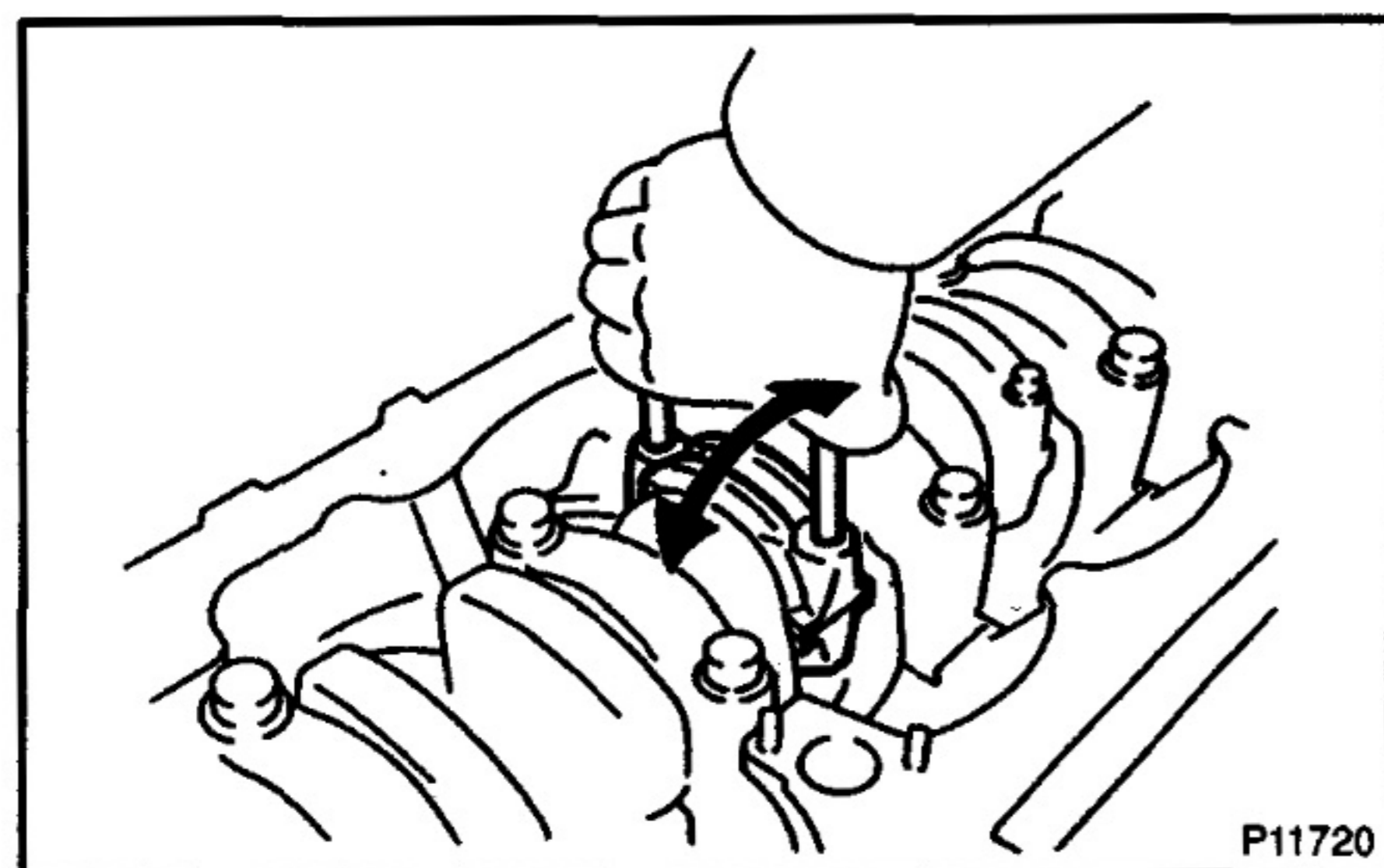

- (h) Remove the 2 bolts, connecting rod cap and lower bearing (See procedure (b) and (c) above).

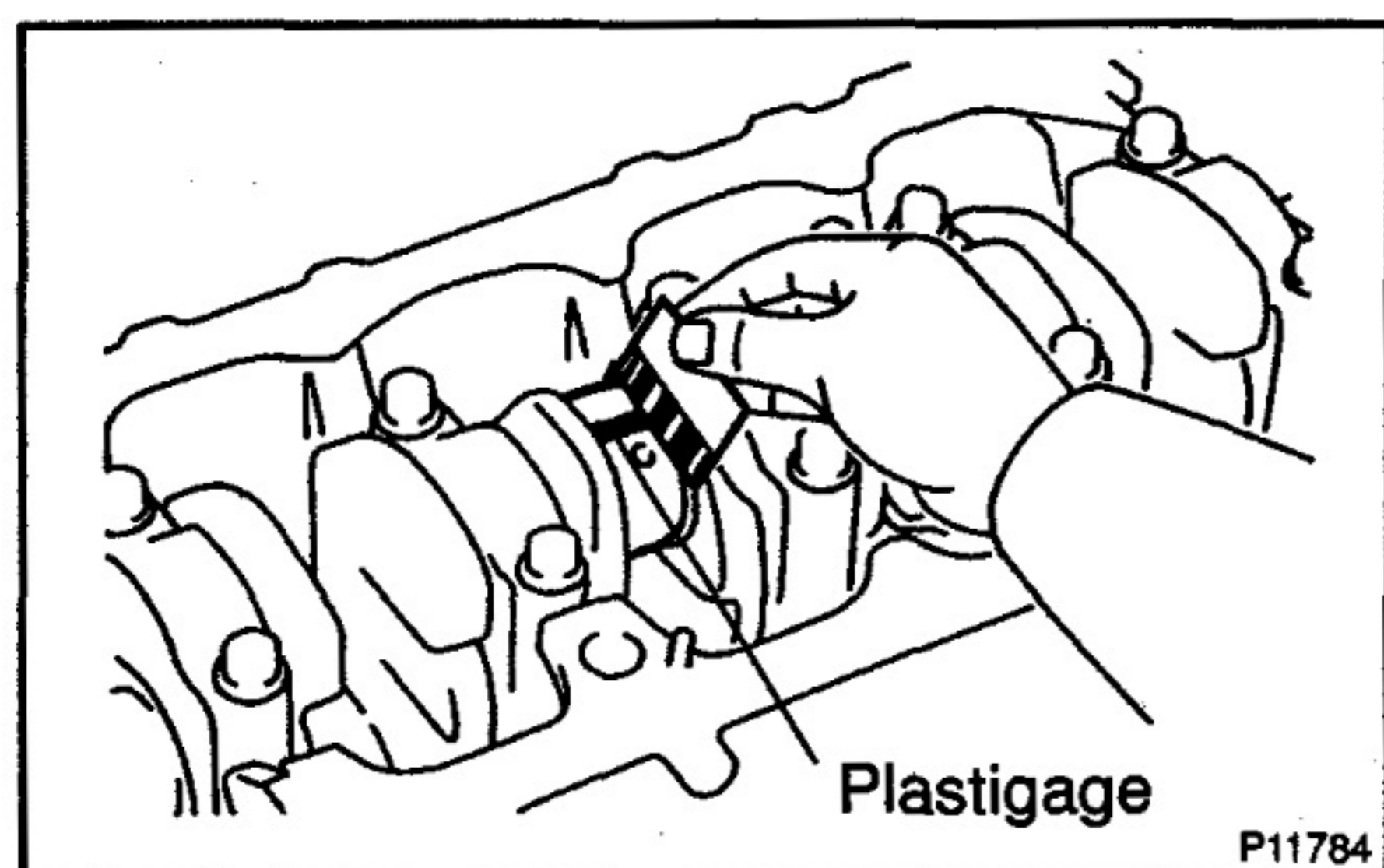

- (i) Measure the Plastigage at its widest point.

Standard oil clearance:

0.036 – 0.054 mm (0.0014 – 0.0021 in.)

Maximum oil clearance: 0.10 mm (0.0039 in.)

If the oil clearance is greater than maximum, replace the bearings. If necessary, grind or replace the crankshaft.

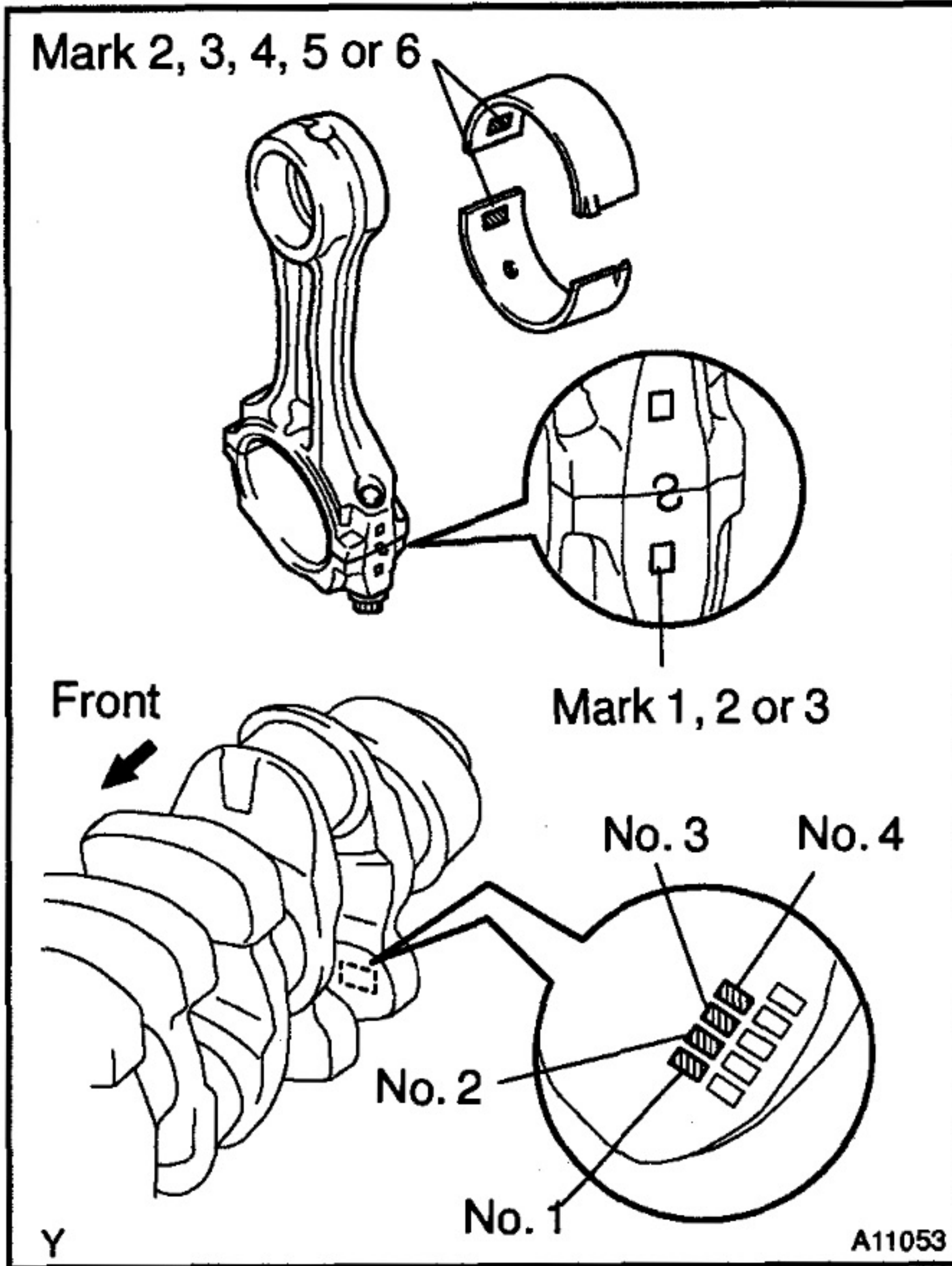

HINT:

If using a standard bearing, replace it with one having the same number. If the number of the bearing cannot be determined, select the correct bearing by adding together the numbers imprinted on the crankshaft and connecting rod, then selecting the bearing with the same number as the total. There are 5 sizes of standard bearings, marked "2", "3", "4", "5" and "6" accordingly.

	Number Marked								
	1			2			3		
Connecting rod									
Crankshaft	1	2	3	1	2	3	1	2	3
Use bearing	2	3	4	3	4	5	4	5	6

EXAMPLE: Connecting rod "2" + Crankshaft "1"
= Total number 3 (Use bearing "3")

Y

A11054

Reference

Connecting rod big end inner diameter:

Mark "1"	62.014 – 62.020 mm (2.4415 – 2.4417 in.)
Mark "2"	62.020 – 62.026 mm (2.4417 – 2.4420 in.)
Mark "3"	62.026 – 62.032 mm (2.4420 – 2.4422 in.)

Crankshaft pin diameter:

Mark "1"	58.994 – 59.000 mm (2.3226 – 2.3228 in.)
Mark "2"	58.988 – 58.994 mm (2.3224 – 2.3226 in.)
Mark "3"	58.982 – 58.988 mm (2.3221 – 2.3224 in.)

Standard sized bearing center wall thickness:

Mark "2"	1.486 – 1.489 mm (0.0585 – 0.0586 in.)
Mark "3"	1.489 – 1.492 mm (0.0586 – 0.0587 in.)
Mark "4"	1.492 – 1.495 mm (0.0587 – 0.0589 in.)
Mark "5"	1.495 – 1.498 mm (0.0589 – 0.0590 in.)
Mark "6"	1.498 – 1.501 mm (0.0590 – 0.0591 in.)

(j) Completely remove the Plastigage.

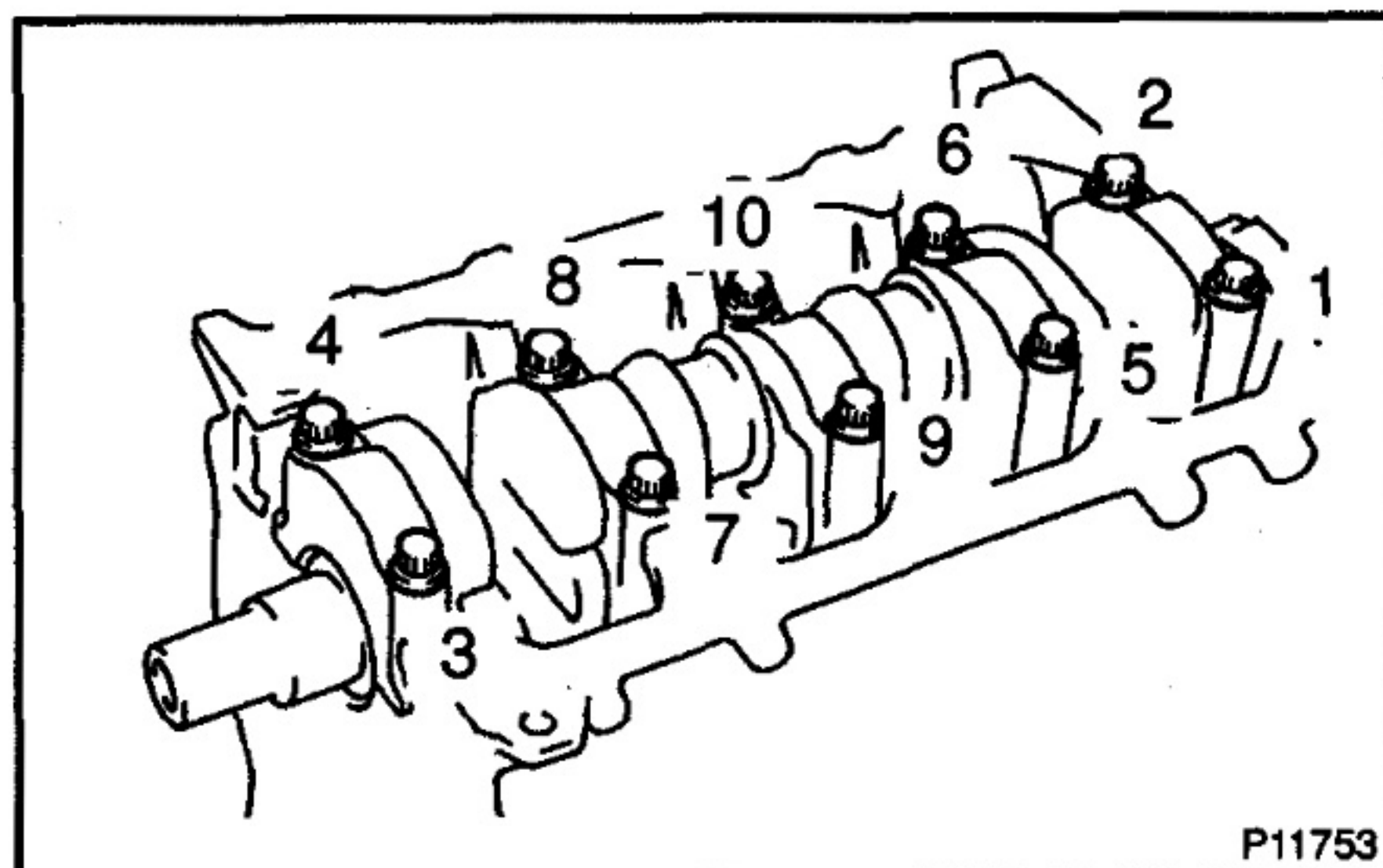

2. REMOVE MAIN BEARING CAPS AND CHECK OIL CLEARANCE

(a) Uniformly loosen and remove the main bearing cap bolts in several passes, in the sequence shown.

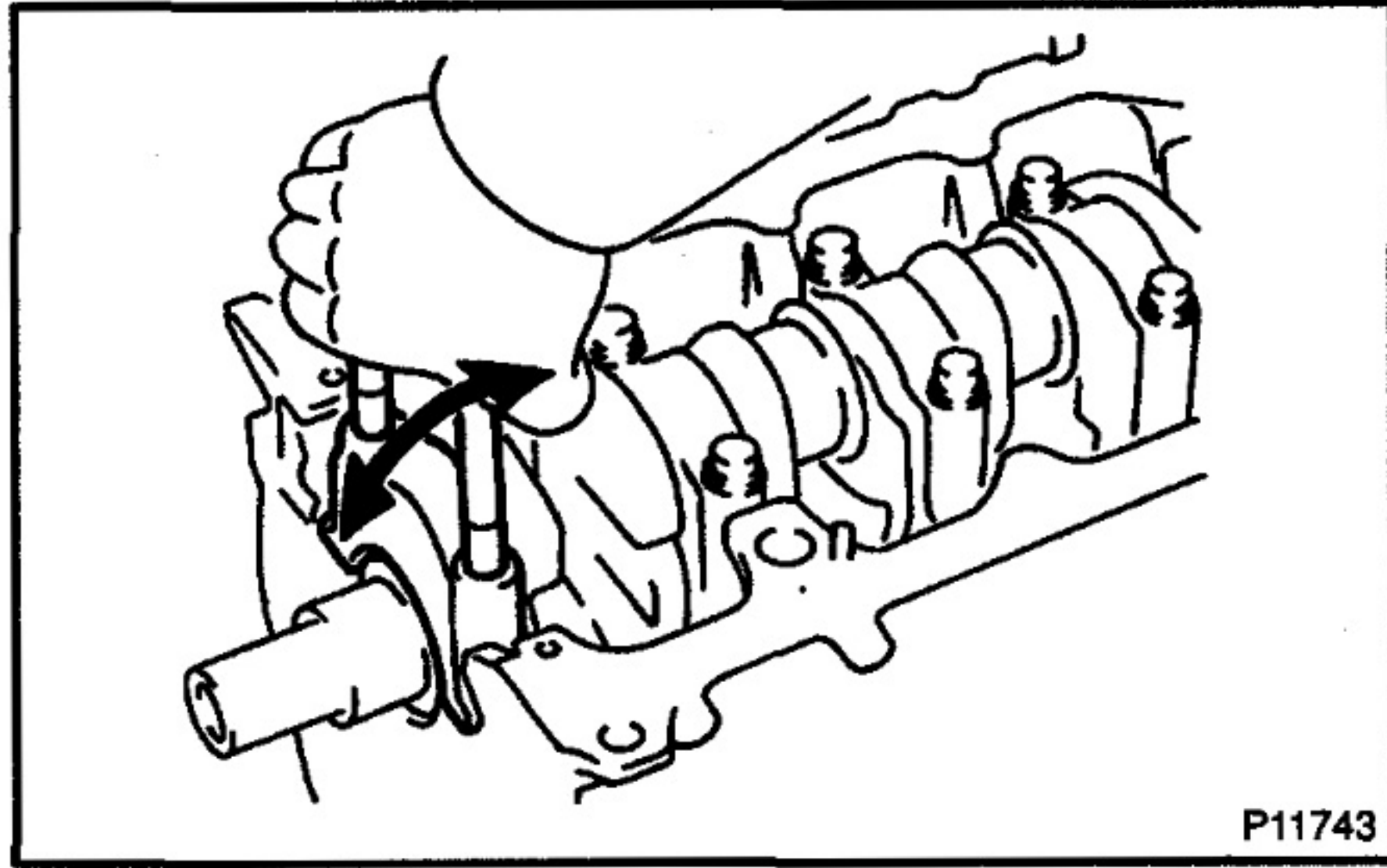

- (b) Using the removed main bearing cap bolts, pry the main bearing cap back and forth, and remove the main bearing caps, lower bearings and lower thrust washers (No.5 main bearing cap only).

HINT:

- Keep the lower bearing and main bearing cap together.
- Arrange the main bearing caps and lower thrust washers in correct order.

- (c) Lift out the crankshaft.

HINT:

Keep the upper bearings and upper thrust washers together with the cylinder block.

- (d) Clean each main journal and bearing.
 (e) Check each main journal and bearing for pitting and scratches.

If the journal or bearing is damaged, replace the bearings. If necessary, grind or replace the crankshaft.

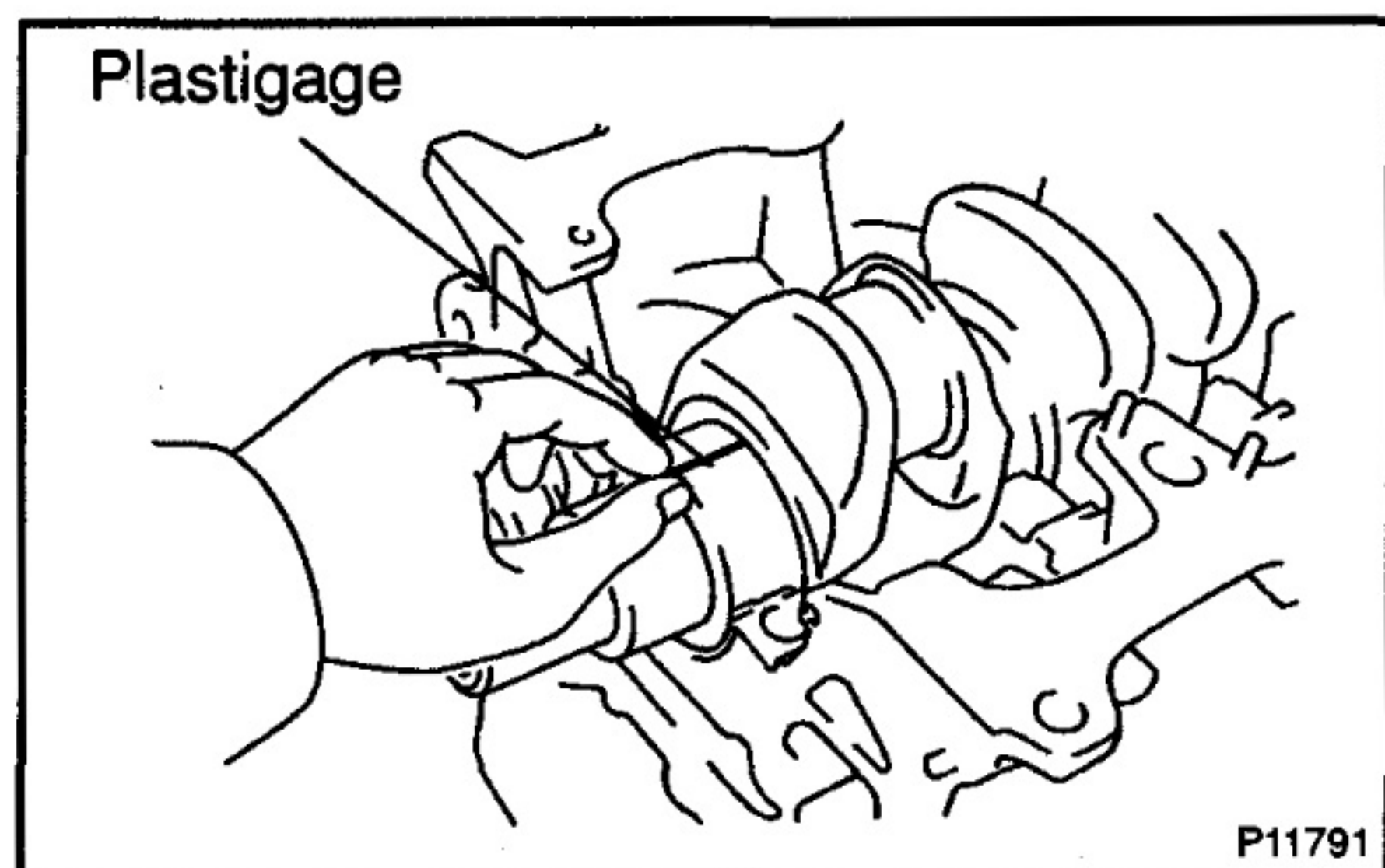

- (f) Place the crankshaft on the cylinder block.
 (g) Lay a strip of Plastigage across each journal.
 (h) Install the main bearing caps (See Pub. No. RM710E, page EM-94).

Torque:

1st: 50 N·m (500 kgf·cm, 36 ft·lbf)

2nd: Turn 90°

NOTICE:

Do not turn the crankshaft.

- (i) Remove the main bearing caps (See procedure (a) and (b) above).

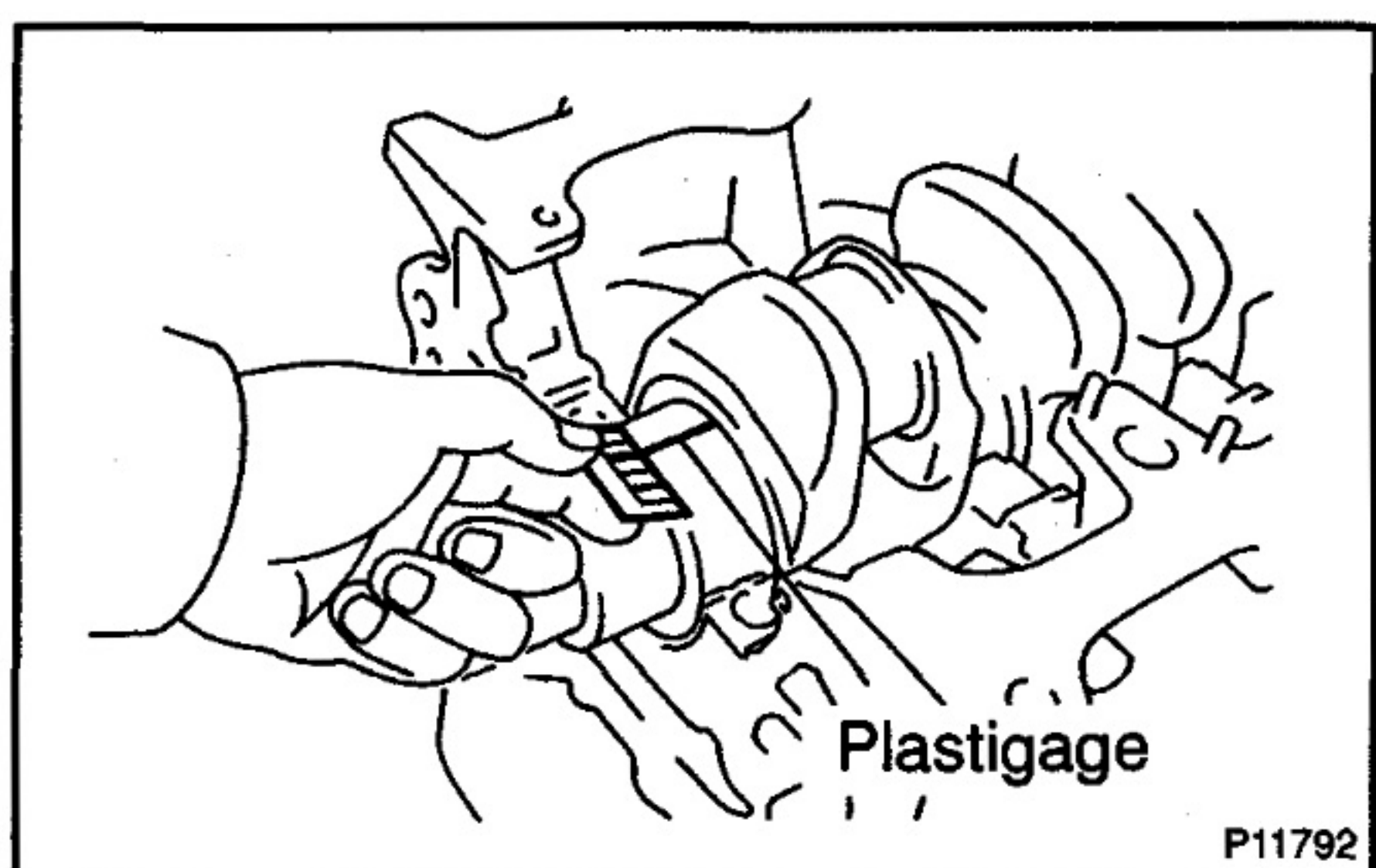

- (j) Measure the Plastigage at its widest point.

Standard clearance:

0.036 – 0.054 mm (0.0014 – 0.0021 in.)

Maximum clearance: 0.10 mm (0.0039 in.)

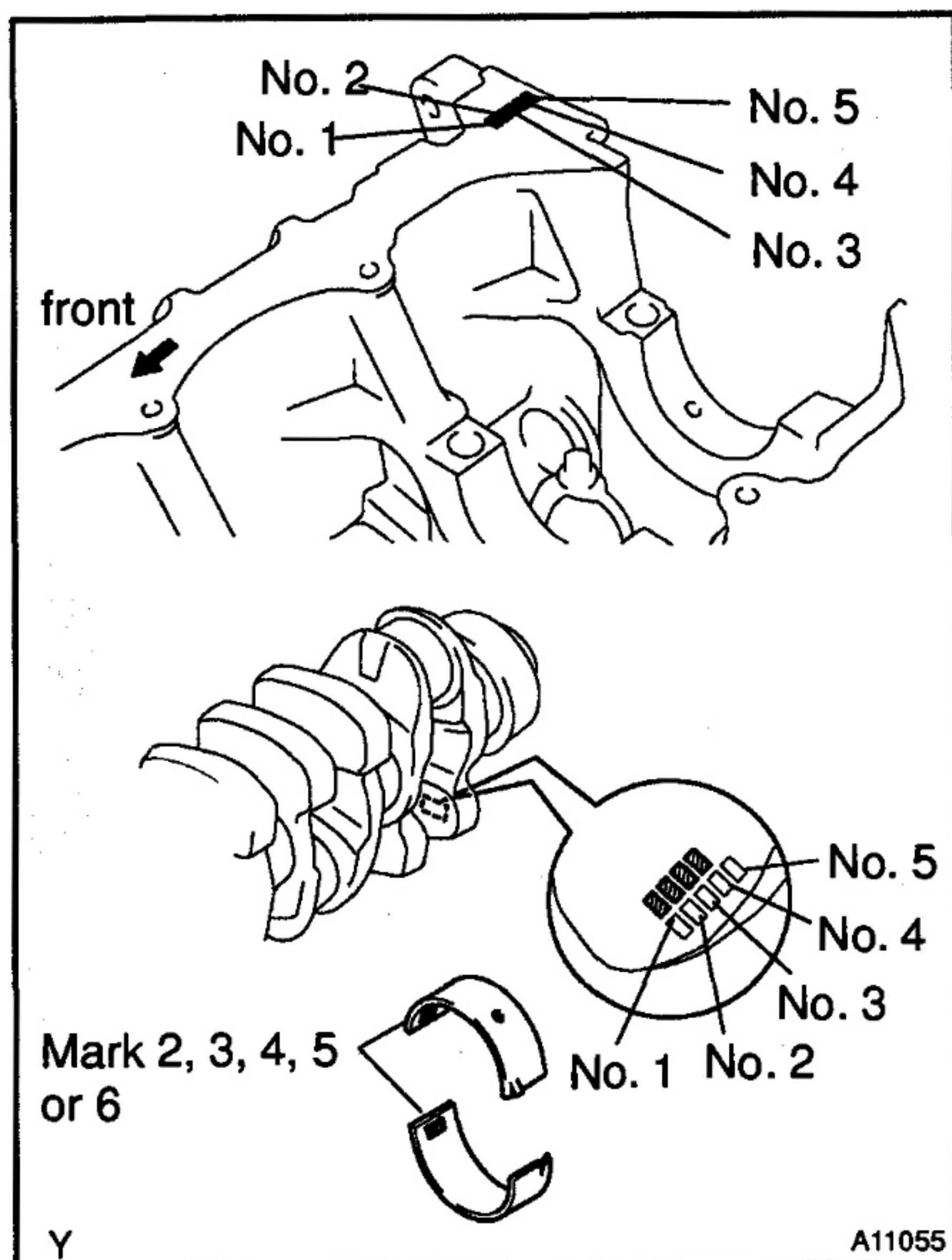
**HINT:**

If replacing the cylinder block subassembly, the bearing standard clearance will be:

0.036 – 0.054 mm (0.0014 – 0.0021 in.)

If the oil clearance is greater than maximum, replace the bearings. If necessary, grind or replace the crankshaft.

HINT:

If using a standard bearing, replace it with one having the same number. If the number of the bearing cannot be determined, select the correct bearing by adding together the numbers imprinted on the cylinder block and crankshaft, then selecting the bearing with the same number as the total. There are 5 sizes of standard bearings, marked "2", "3", "4", "5" and "6" accordingly.

	Number Marked								
	1			2			3		
Cylinder block									
Crankshaft	1	2	3	1	2	3	1	2	3
Use bearing	2	3	4	3	4	5	4	5	6

EXAMPLE: Cylinder block "2" + Crankshaft "1"
= Total number 3 (Use bearing "3")

Y

A11056

Reference**Cylinder block main journal bore diameter:**

Mark "1"	75.000 – 75.006 mm (2.9528 – 2.9530 in.)
Mark "2"	75.006 – 75.012 mm (2.9530 – 2.9532 in.)
Mark "3"	75.012 – 75.018 mm (2.9532 – 2.9535 in.)

Crankshaft journal diameter:

Mark "1"	69.994 – 70.000 mm (2.7557 – 2.7559 in.)
Mark "2"	69.988 – 69.994 mm (2.7554 – 2.7557 in.)
Mark "3"	69.982 – 69.988 mm (2.7552 – 2.7554 in.)

Standard sized bearing center wall thickness:

Mark "2"	2.482 – 2.485 mm (0.0977 – 0.0978 in.)
Mark "3"	2.485 – 2.488 mm (0.0978 – 0.0980 in.)
Mark "4"	2.488 – 2.491 mm (0.0980 – 0.0981 in.)
Mark "5"	2.491 – 2.494 mm (0.0981 – 0.0982 in.)
Mark "6"	2.494 – 2.497 mm (0.0982 – 0.0983 in.)

(k) Completely remove the Plastigage.

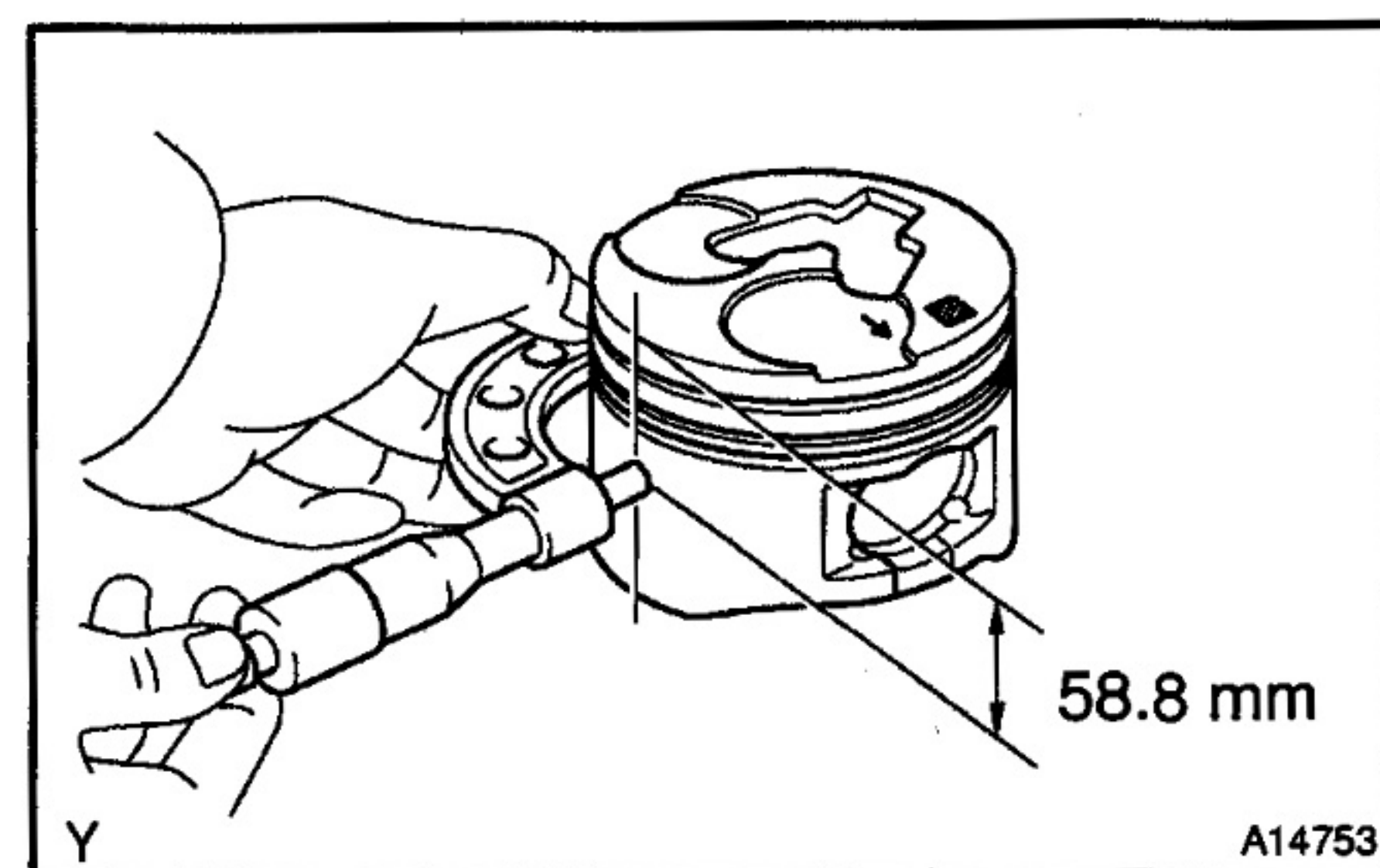
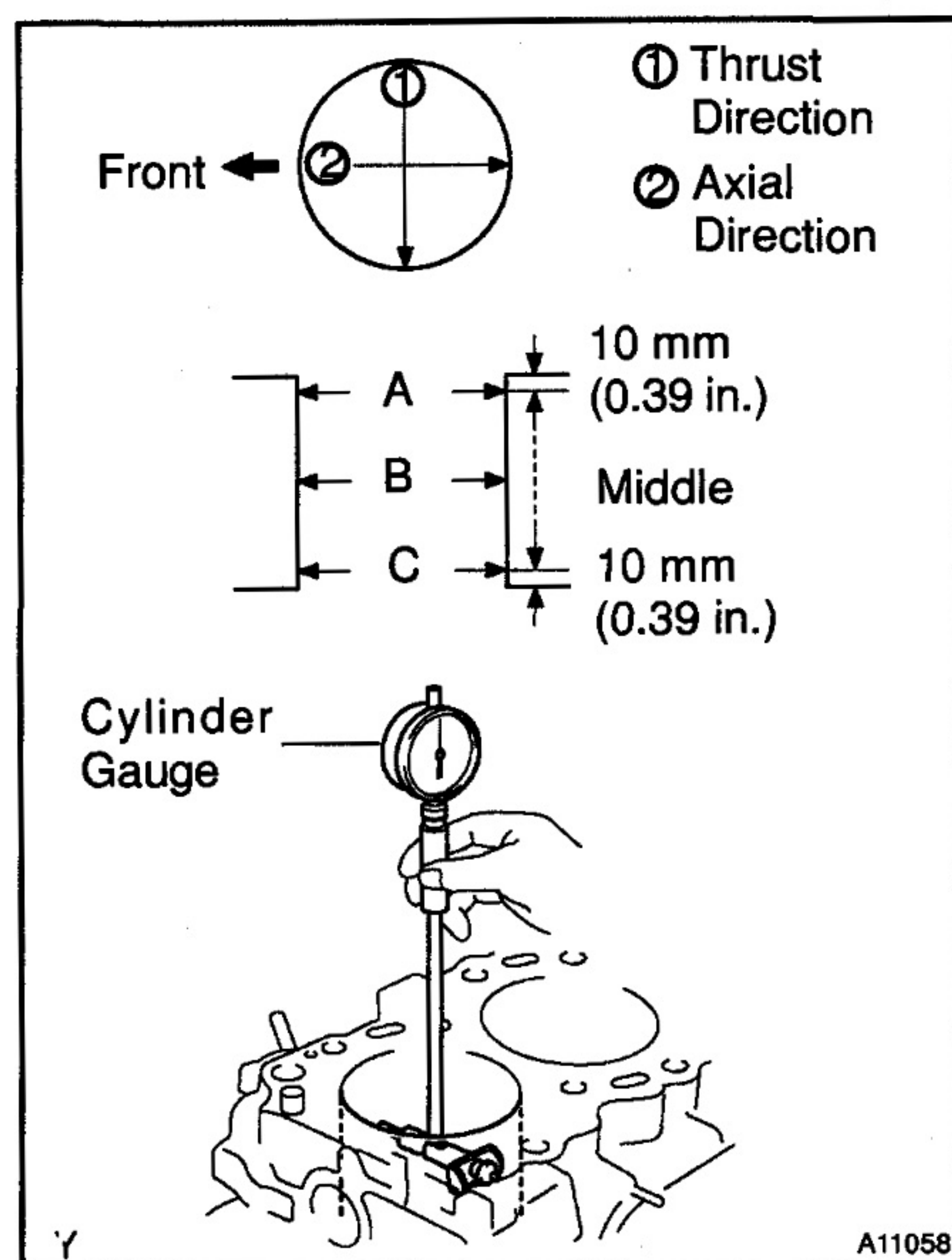
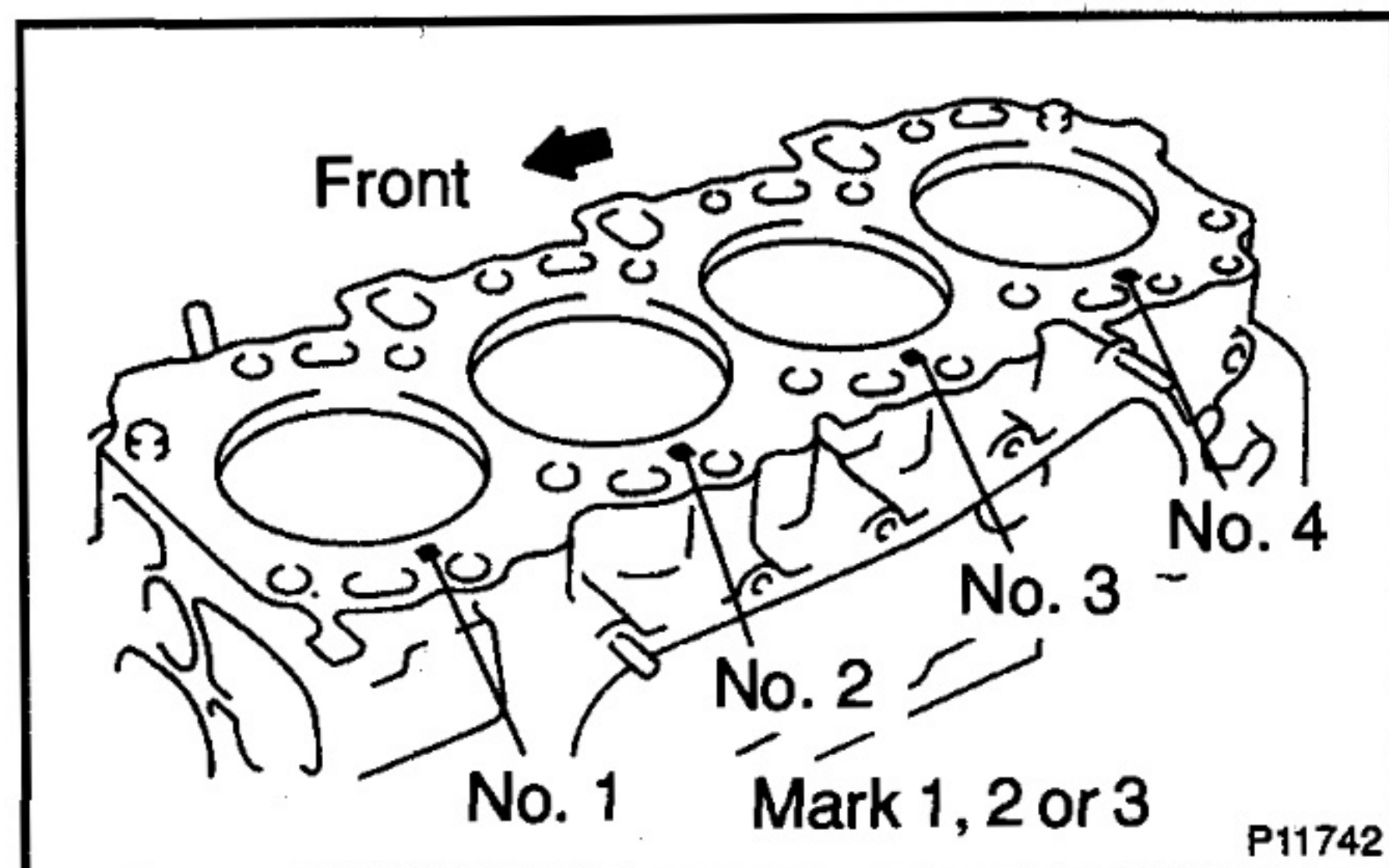

INSPECTION

1. INSPECT CYLINDER BORE DIAMETER

HINT:

There are 3 sizes of the standard cylinder bore diameter, marked "1", "2" and "3" accordingly. The mark is stamped on the top of the cylinder block.

Using a cylinder gauge, measure the cylinder bore diameter at positions A, B and C in the thrust and axial directions.

Standard diameter:

STD Mark 1	96.000 – 96.010 mm (3.7795 – 3.7799 in.)
STD Mark 2	96.010 – 96.020 mm (3.7799 – 3.7803 in.)
STD Mark 3	96.020 – 96.030 mm (3.7803 – 3.7807 in.)

Maximum diameter:

STD	96.23 mm (3.7886 in.)
O/S 0.50	96.73 mm (3.8083 in.)
O/S 0.75	96.96 mm (3.8137 in.)
O/S 1.00	97.23 mm (3.8279 in.)

If the diameter is greater than maximum, rebore all the 4 cylinders. If necessary, replace the cylinder block.

2. INSPECT PISTON AND PISTON RING

(a) Inspect the piston oil clearance.

HINT:

There are 3 sizes of the standard piston diameter, marked "1", "2" and "3" accordingly. The mark is stamped on the piston top.

- Using a micrometer, measure the piston diameter at right angles to the piston pin center line, 58.8 mm (2.315 in.) from the piston head.

Piston diameter:

STD Mark 1	95.940 – 95.950 mm (3.7772 – 3.7776 in.)
STD Mark 2	95.950 – 95.960 mm (3.7776 – 3.7779 in.)
STD Mark 3	95.960 – 95.970 mm (3.7779 – 3.7783 in.)
O/S 0.50	96.440 – 96.470 mm (3.7968 – 3.7980 in.)
O/S 0.75	96.690 – 96.720 mm (3.8067 – 3.8079 in.)
O/S 1.00	96.940 – 96.970 mm (3.8165 – 3.8177 in.)

- Measure the cylinder bore diameter in the thrust directions (See step 1 above).

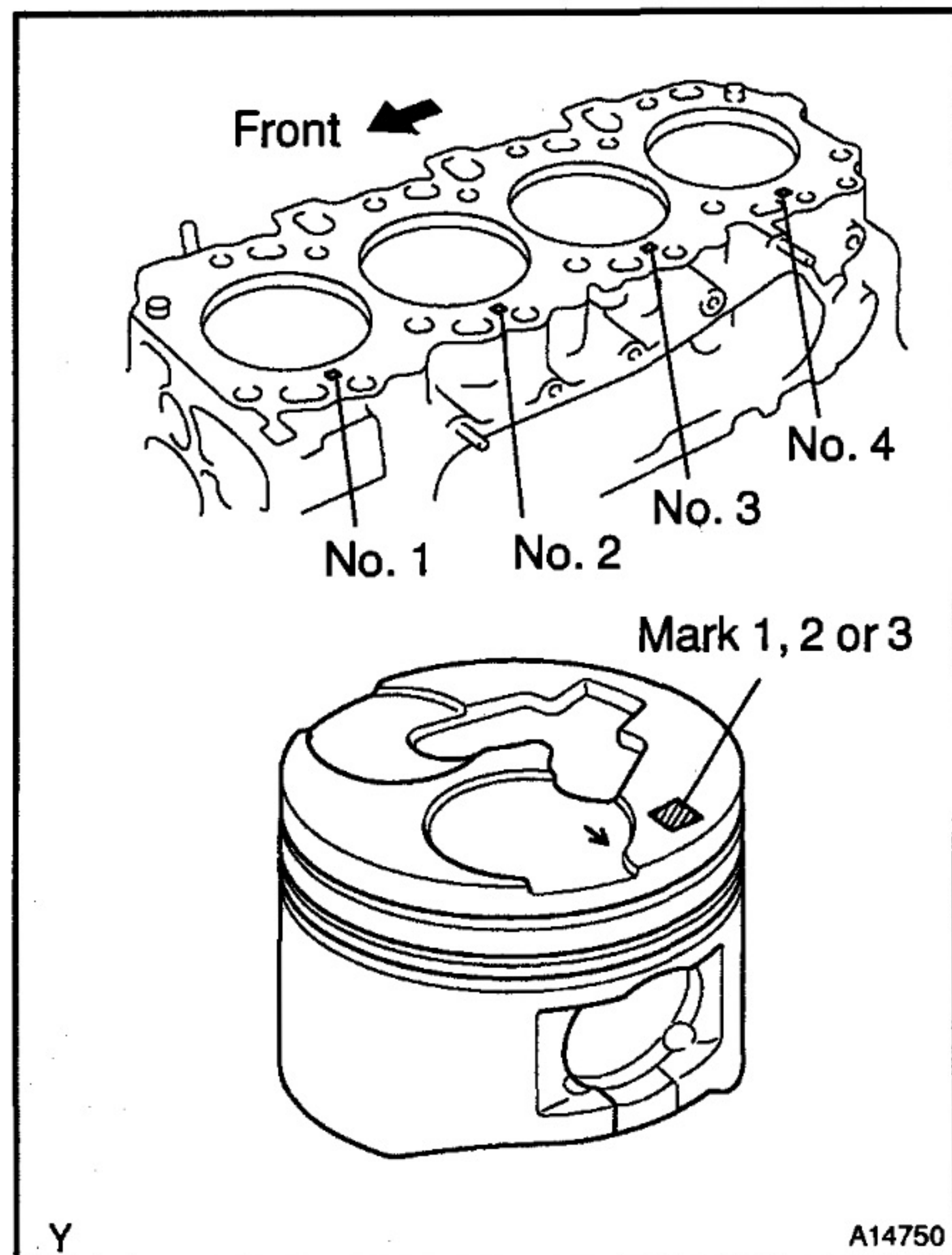

(3) Subtract the piston diameter measurement from the cylinder bore diameter measurement.

Standard oil clearance:

0.050 – 0.070 mm (0.0020 – 0.0028 in.)

Maximum oil clearance: 0.14 mm (0.0055 in.)

If the oil clearance is greater than maximum, replace all the 4 pistons and rebore all the 4 cylinders. If necessary, replace the cylinder block.

HINT:

Use new cylinder block: Use a piston with the same number mark as the cylinder bore diameter marked on the cylinder block.

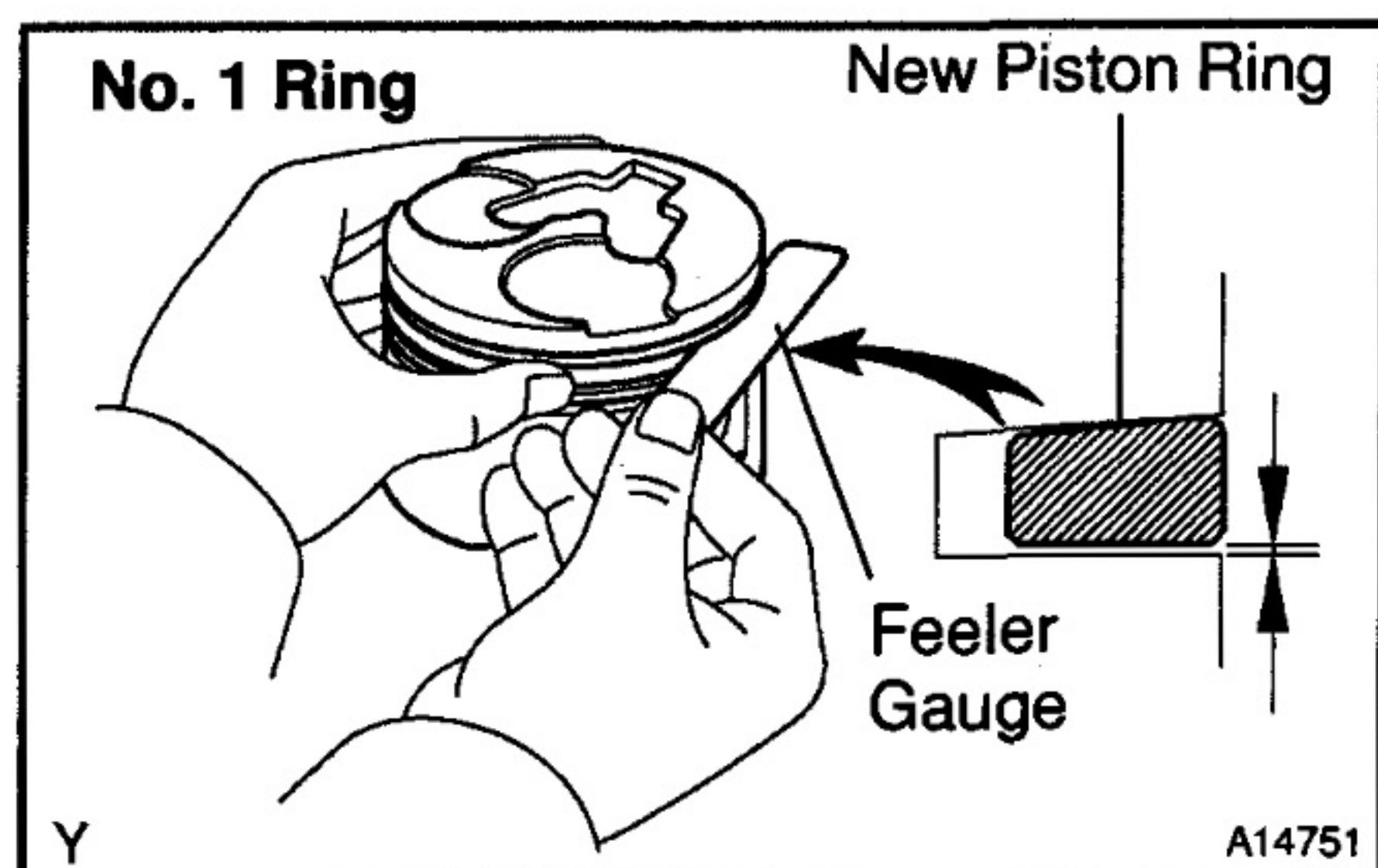

(b) Inspect the piston ring groove clearance.

(1) No. 1 ring:

Install a new No. 1 piston ring to the piston. Using a feeler gauge, measure the clearance between new piston ring and the wall of the ring groove.

Ring groove clearance (No. 1):

0.061 – 0.105 mm (0.0024 – 0.0043 in.)

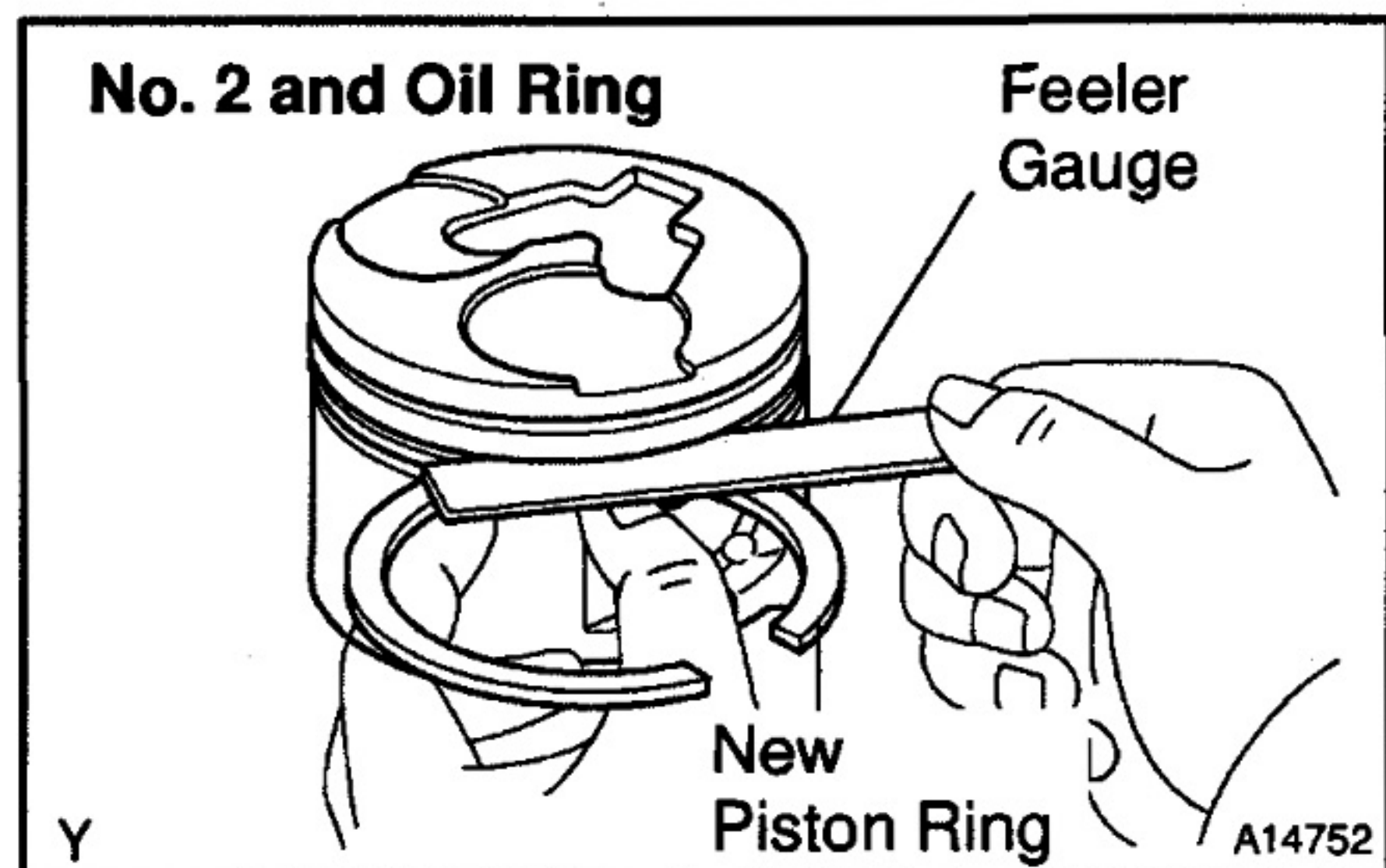

(2) No. 2 and oil ring:

Using a feeler gauge, measure the clearance between the new piston ring and the wall of the ring groove.

Ring groove clearance (No. 2 and oil ring):

No. 2	0.060 – 0.100 mm (0.0024 – 0.0039 in.)
Oil	0.020 – 0.060 mm (0.0009 – 0.0024 in.)

If the clearance is greater than maximum, replace the piston.

REPLACEMENT

REPLACE OVERSIZED (O/S) PISTONS

HINT:

- Bore all the 4 cylinders to the O/S piston outside diameter.
- Replace all the piston rings with ones to match the O/S pistons.

(a) Keep the O/S pistons.

O/S piston diameter:

O/S 0.50	96.440 – 96.470 mm (3.7968 – 3.7980 in.)
O/S 0.75	96.690 – 96.720 mm (3.8067 – 3.8079 in.)
O/S 1.00	96.940 – 96.970 mm (3.8165 – 3.8177 in.)

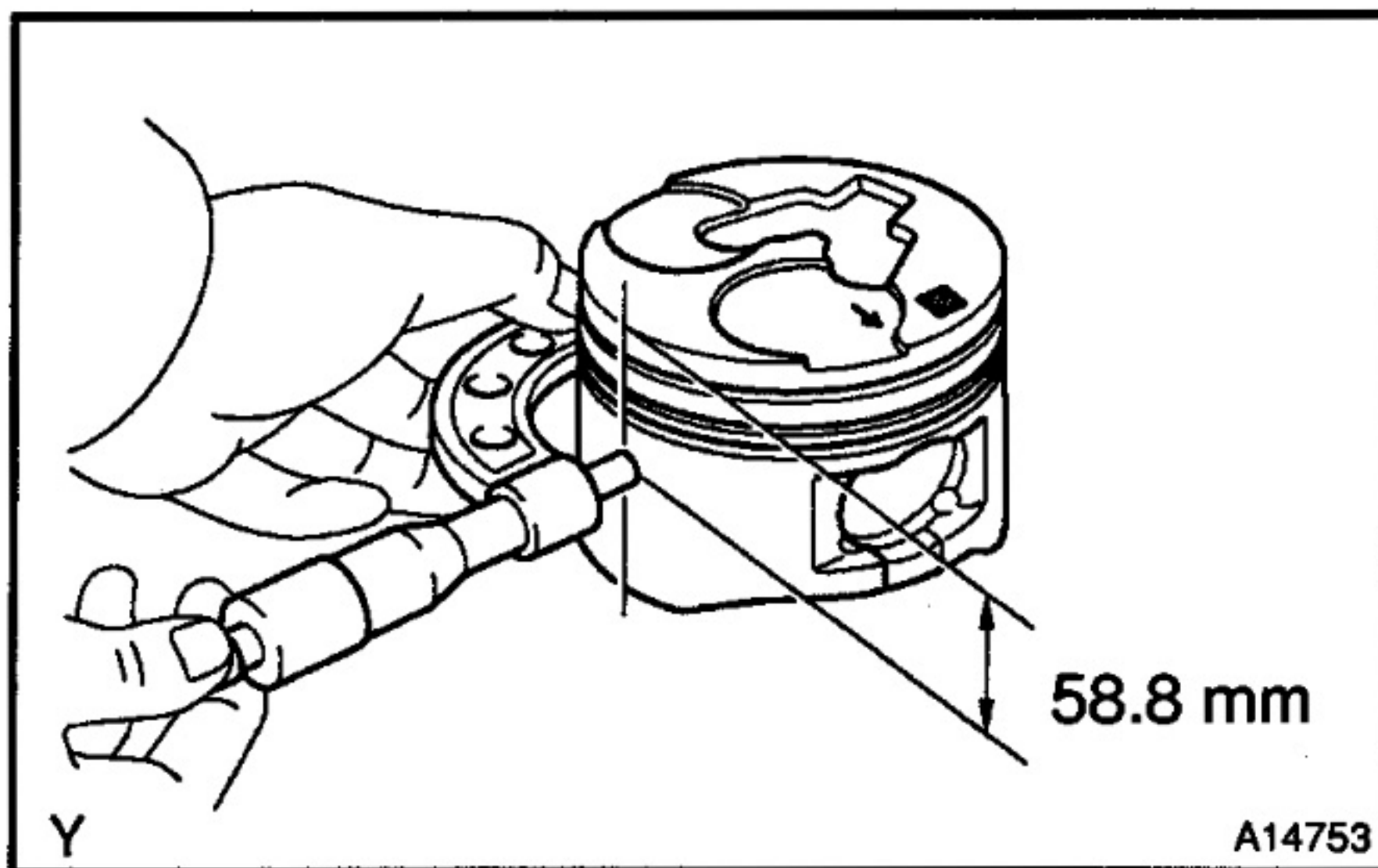

(b) Using a micrometer, measure the piston diameter at right angles to the piston pin center line, 58.8 mm (2.315 in.) from the piston head.

(c) Calculate the amount each cylinder is to be rebored as follows:

$$\text{Size to be rebored} = P + C - H$$

P = Piston diameter

C = Piston clearance

0.050 – 0.070 mm (0.0020 – 0.0028 in.)

H = Allowance for honing

0.02 mm (0.0008 in.) or less

(d) Bore and hone cylinder to calculated dimensions.

Maximum honing: 0.02 mm (0.0008 in.)

NOTICE:

Excess honing will destroy the finished roundness.

REASSEMBLY

HINT:

- Thoroughly clean all parts to be assembled.
- Before installing the parts, apply fresh engine oil to all sliding and rotating surfaces.
- Replace all gaskets, O-rings and oil seals with new parts.

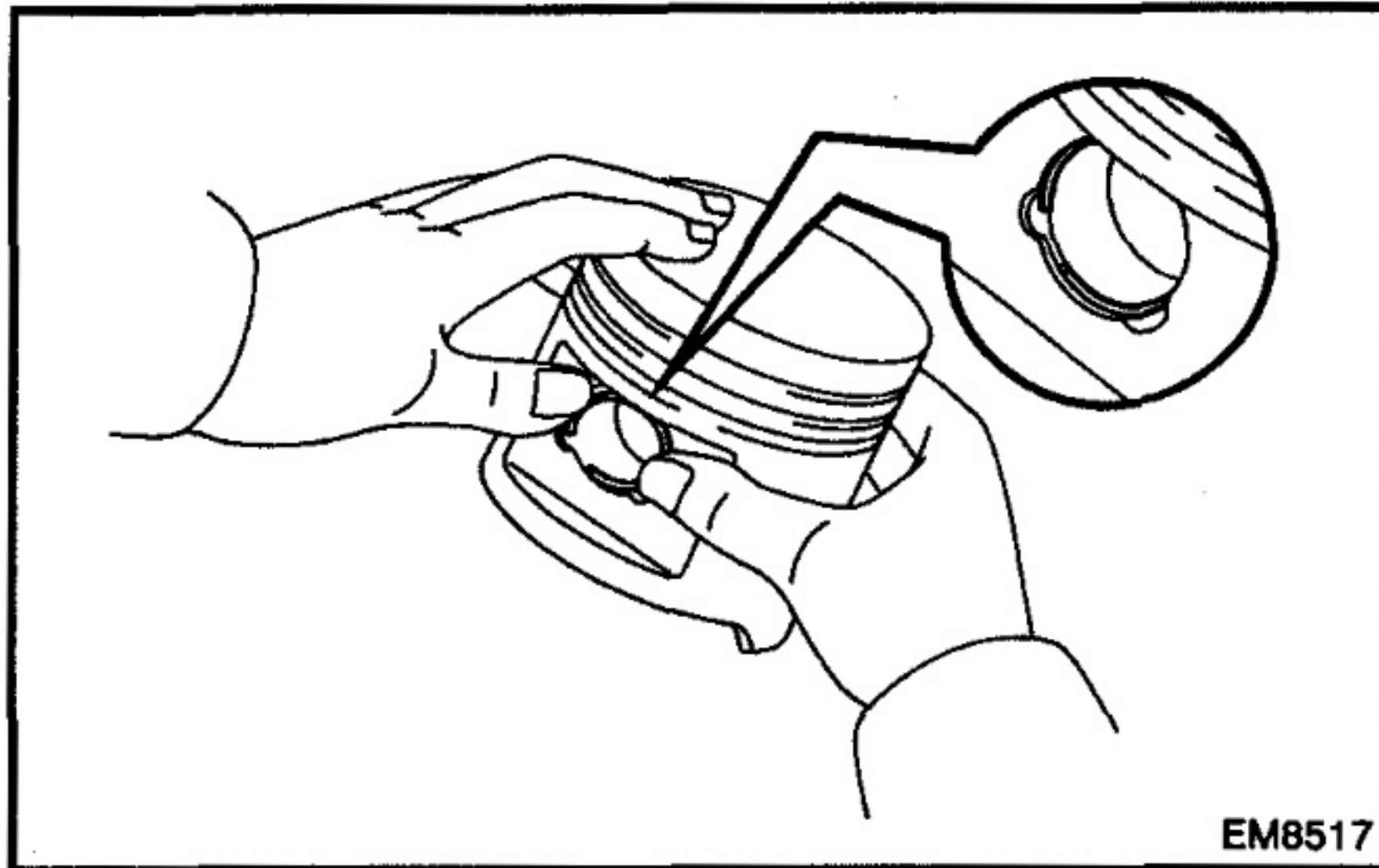

1. ASSEMBLE PISTON AND CONNECTING ROD

- Install a new snap ring on one side of the piston pin hole.
- Gradually heat the piston to 80°C (176°F).
- Coat the piston pin with engine oil.

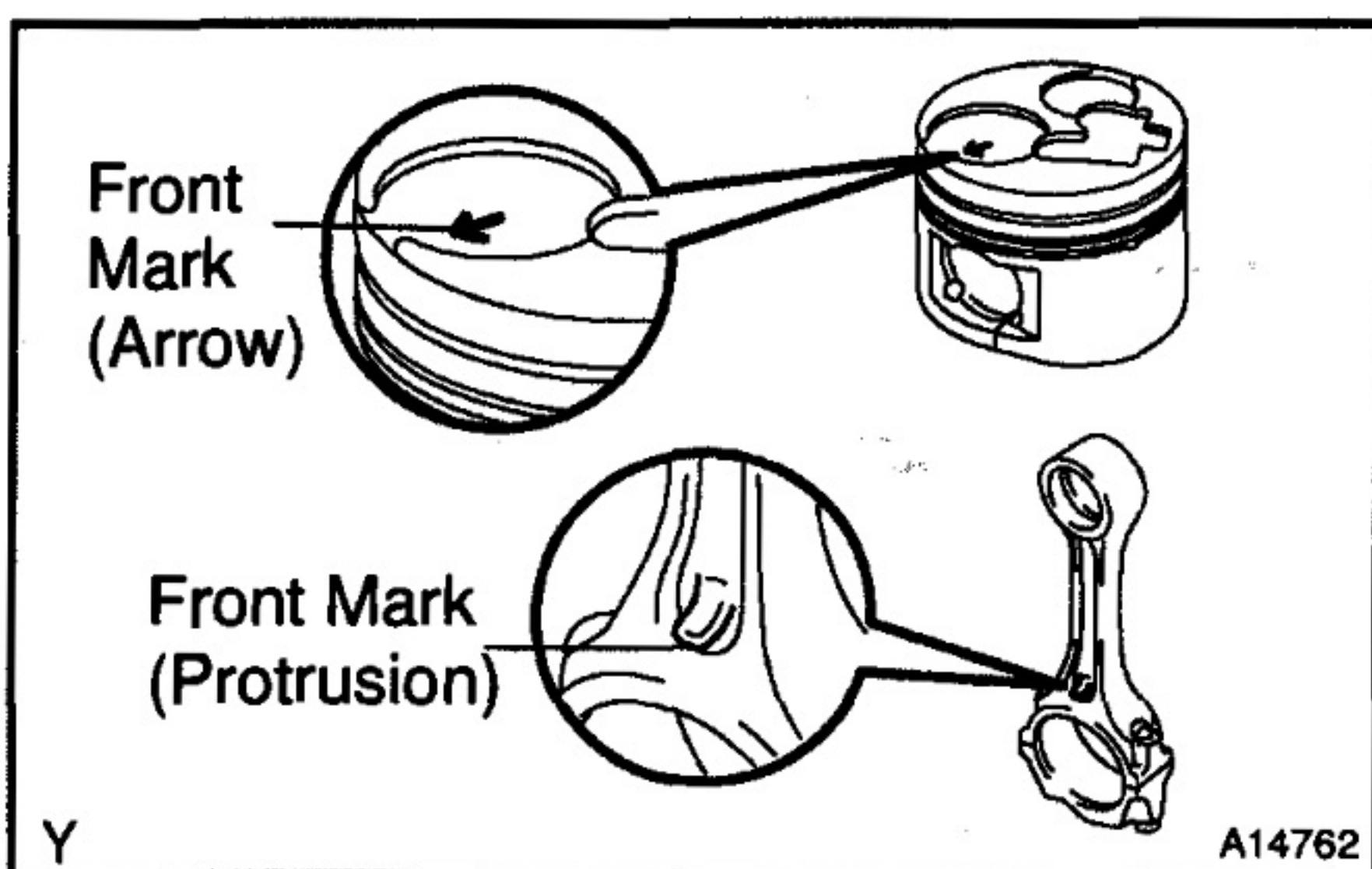

- Align the front marks of the piston and connecting rod, and push in the piston pin with your thumb.
- Install a new snap ring on the other side of the piston pin hole.

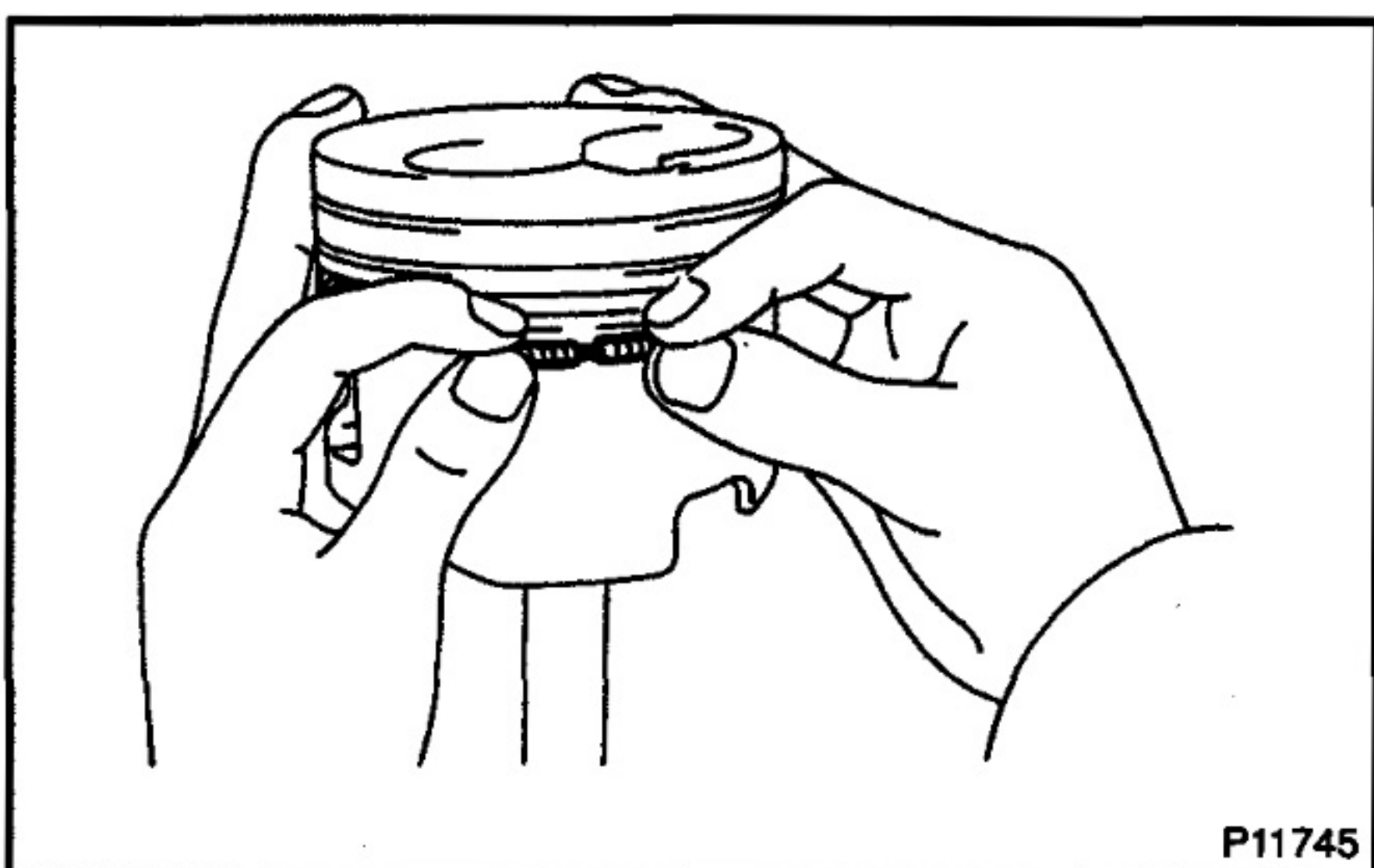

2. INSTALL PISTON RINGS

- Install the coil by hand.
- Install a piston ring expander, install the oil ring.

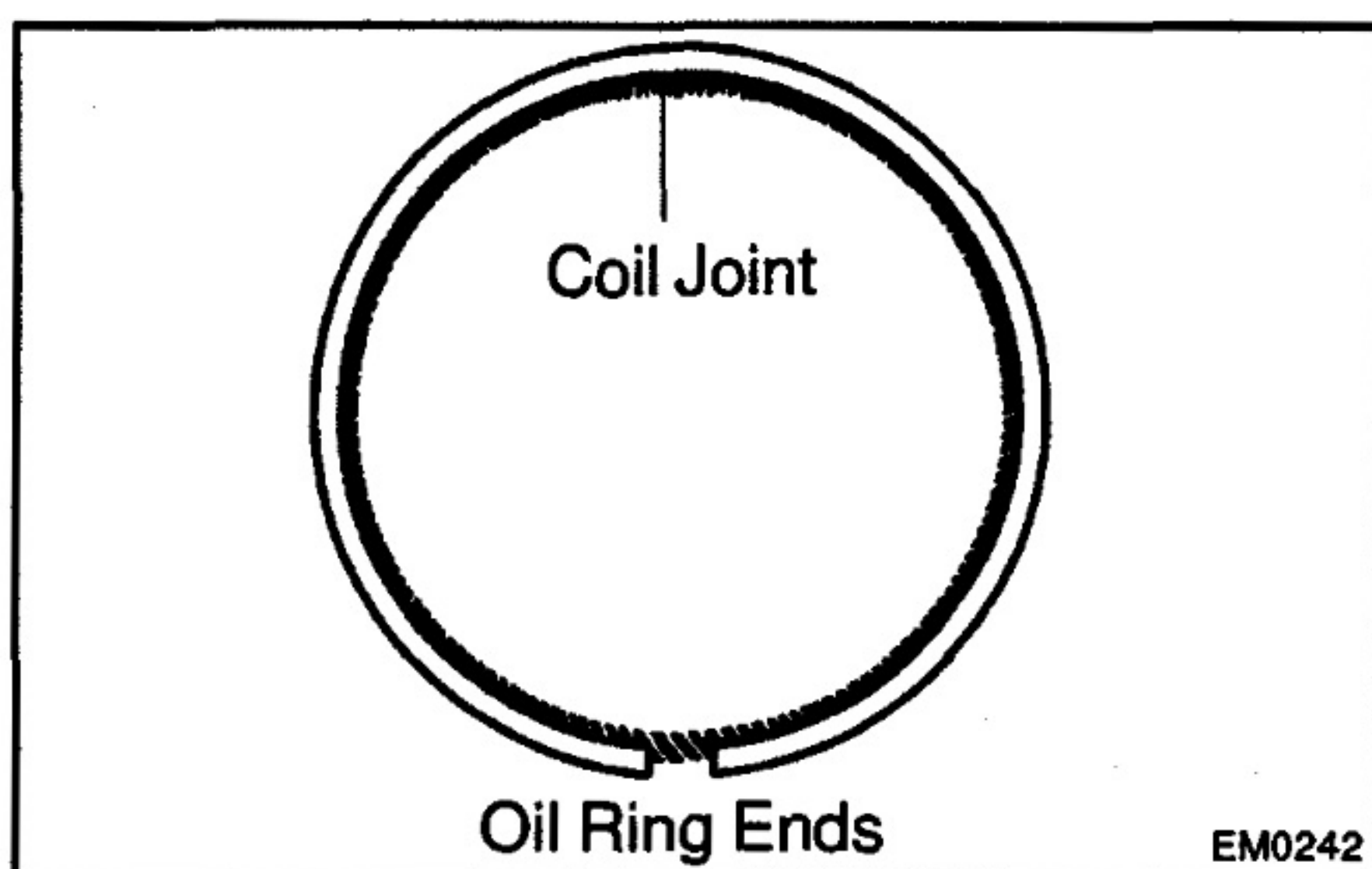

HINT:

Face the end gap of the oil ring in the opposite direction of coil joint.

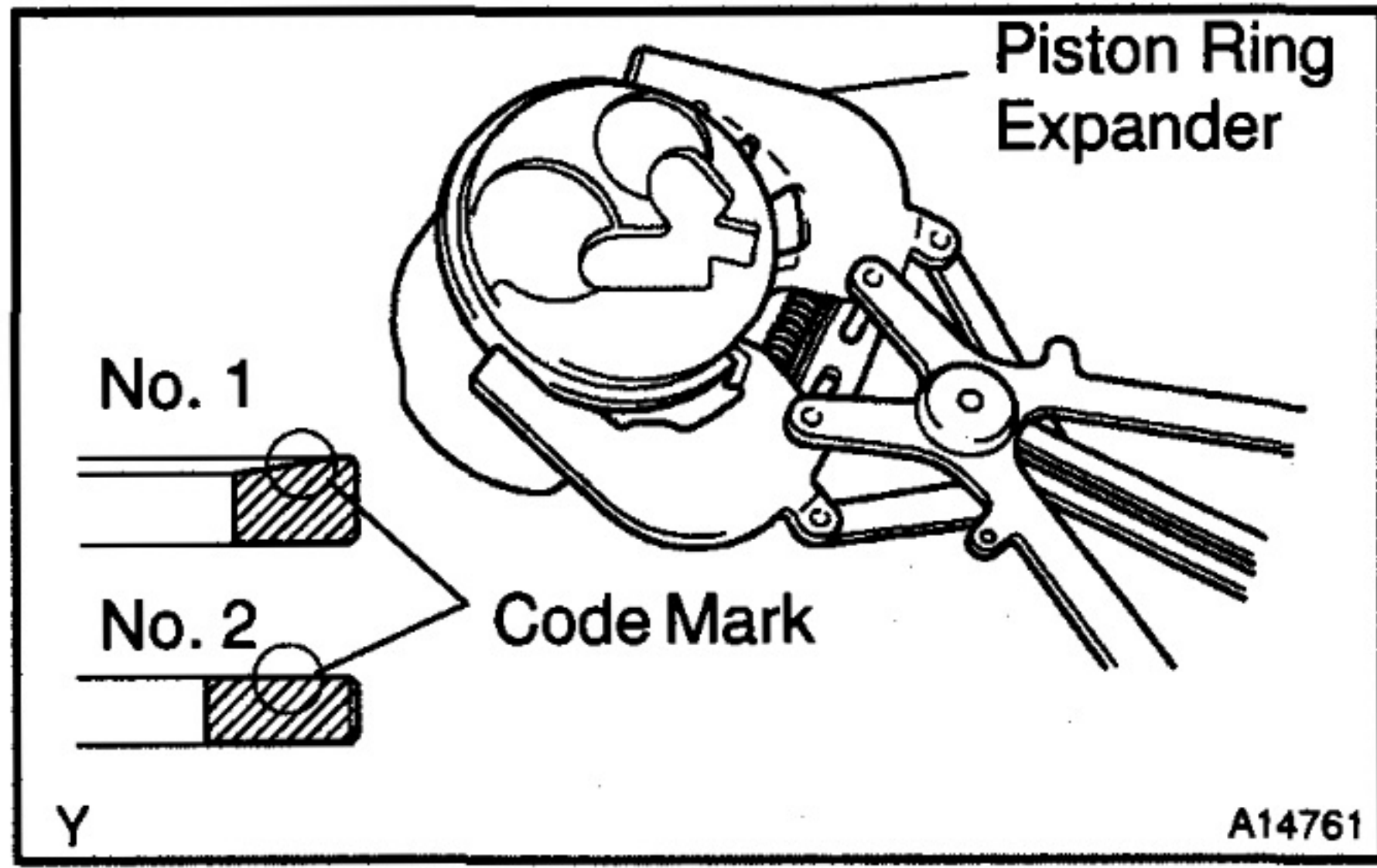

(c) Using a piston ring expander, install the 2 compression rings with the code mark facing upward.

Code mark:

No. 1	1N
No. 2	2N

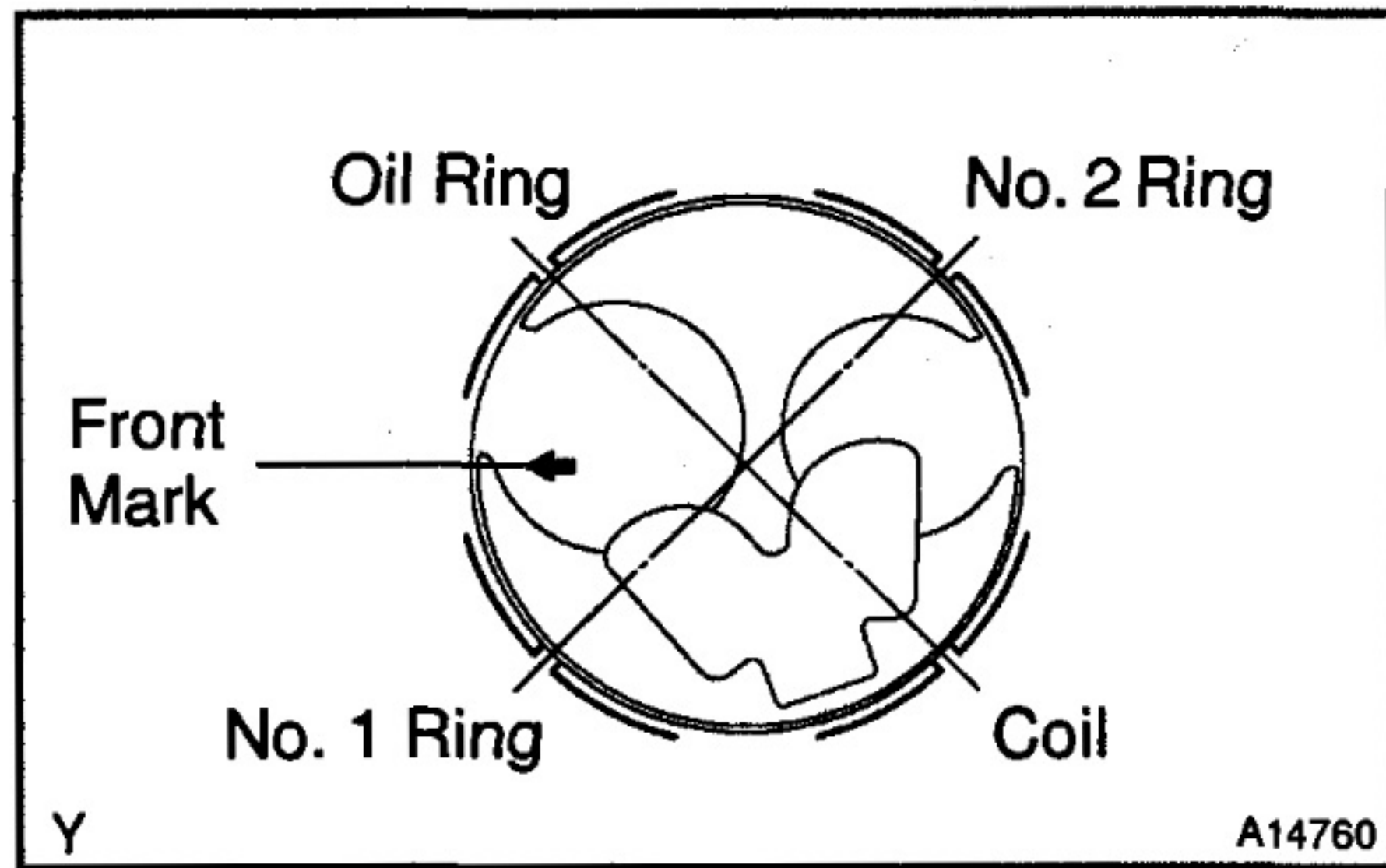

(d) Position the piston rings so that the ring ends are as shown.

NOTICE:

Do not align the ring ends.

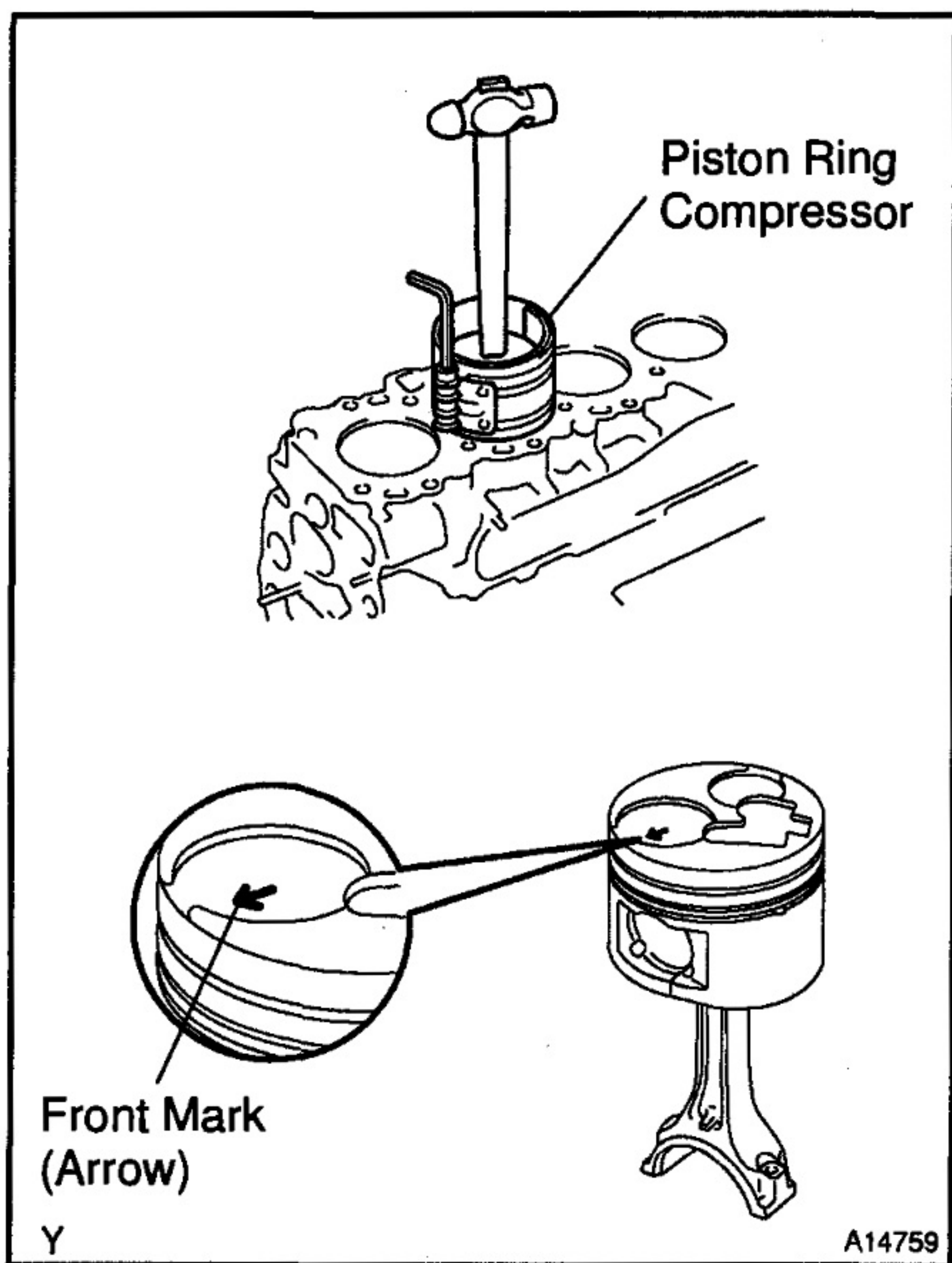

3. INSTALL PISTON AND CONNECTING ROD ASSEMBLIES

Using a piston ring compressor, push the correctly numbered piston and connecting rod assemblies into each cylinder with the front mark of the piston facing forward.

TURBOCHARGING

TURBOCHARGER TC-1
INTERCOOLER TC-10

REFER TO FOLLOWING REPAIR MANUALS:

Manual Name	Pub. No.
1KZ-T Engine Repair Manual	RM353E
1KZ-TE Engine Repair Manual	RM710E
1KZ-T, 1KZ-TE Engine Repair Manual Supplement	RM522E

TC

NOTE: The above pages contain only the points which differ from the above listed manuals.

TURBOCHARGER

ON-VEHICLE INSPECTION

TC01P-03

1. INSPECT INTAKE AIR SYSTEM

Check for leakage or clogging between the air cleaner housing and turbocharger inlet and between the turbocharger outlet and cylinder head.

- Clogged air cleaner Clean or replace element
- Hoses collapsed or deformed Repair or replace
- Leakage from connections Check each connection and repair
- Cracks in components Check and replace

2. INSPECT EXHAUST SYSTEM

Check for leakage or clogging between the cylinder head and turbocharger inlet and between the turbocharger outlet and exhaust pipe.

- Deformed components Repair or replace
- Foreign material in passages Remove
- Leakage from components Repair or replace
- Cracks in components Check and replace

3. CHECK TURBOCHARGER PRESSURE

- (a) Warm up engine.
- (b) Using a 3-way connector, connect SST (turbocharger pressure gauge) to the hose leading to the intake manifold.
SST 09992-00241
- (c) Press in the clutch pedal, then press the accelerator pedal down as far as it will go. Measure the turbocharging pressure at maximum speed (approx. 4,600 rpm).

Standard pressure:

51 – 67 kPa (0.52 – 0.68 kgf/cm², 7.4 – 9.7 psi)

If the pressure is less than specified, check the intake air and exhaust systems for leakage.

If there is no leakage, replace the turbocharger.

If the pressure is above specification, check if the actuator hose is disconnected or cracked. If not, replace the turbocharger.

4. INSPECT IMPELLER WHEEL ROTATION (See page TC-3)

5. INSPECT ACTUATOR OPERATION (See page TC-3)

6. INSPECT TURBO PRESSURE SENOR (See page ED-15)

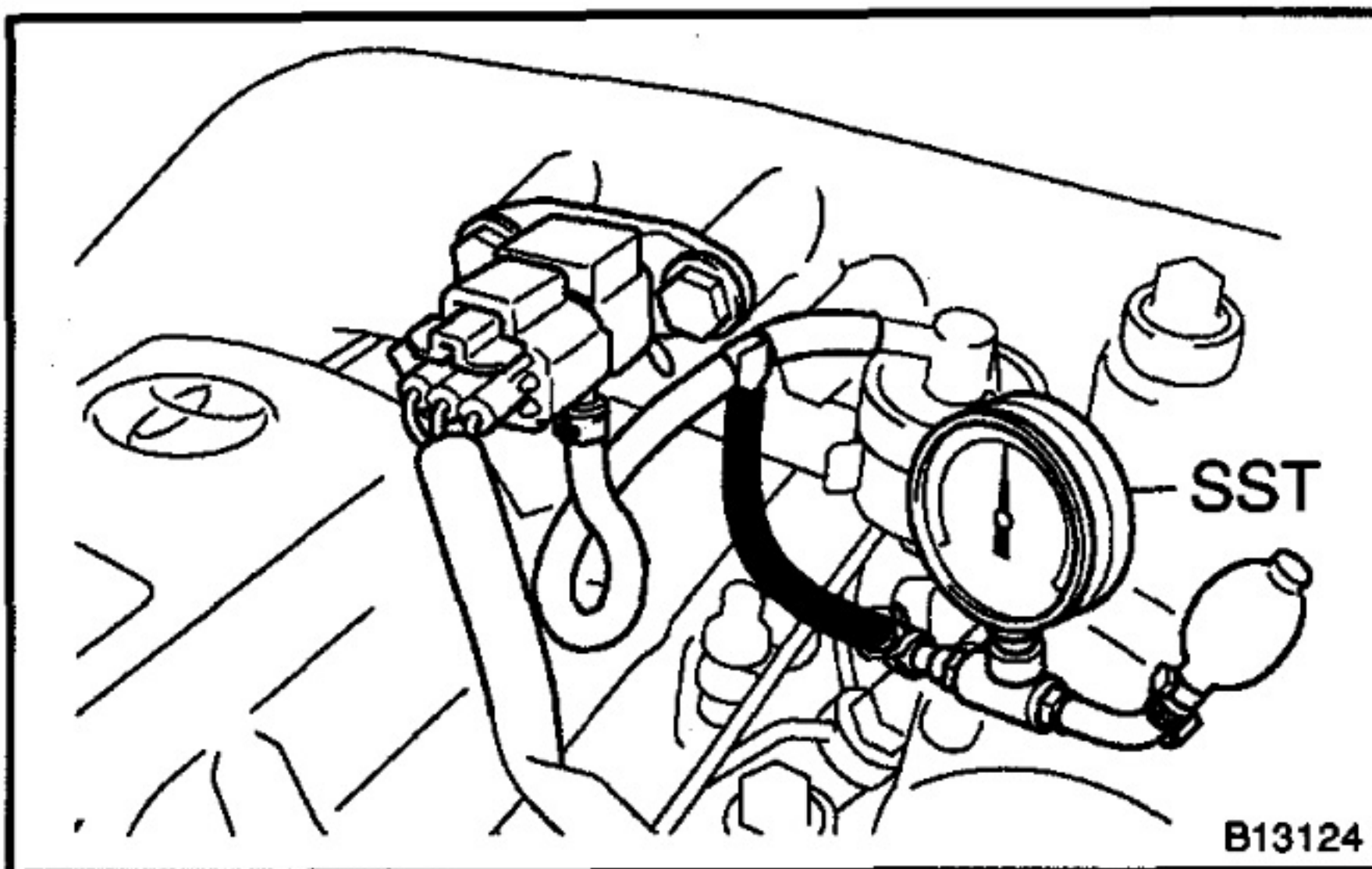

COMPONENTS

TC

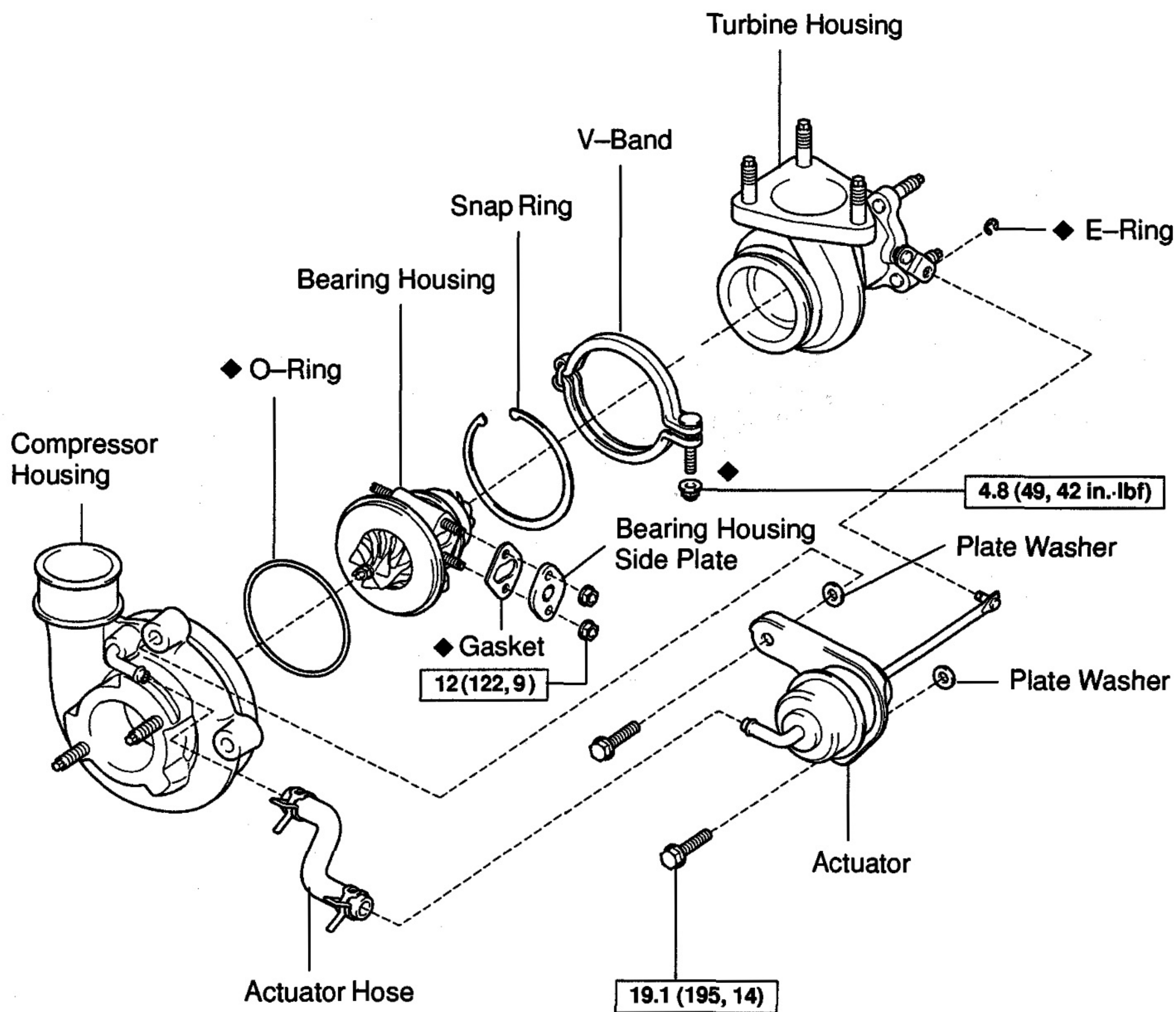

N·m (kgf·cm, ft·lbf) : Specified torque

◆ Non-reusable part

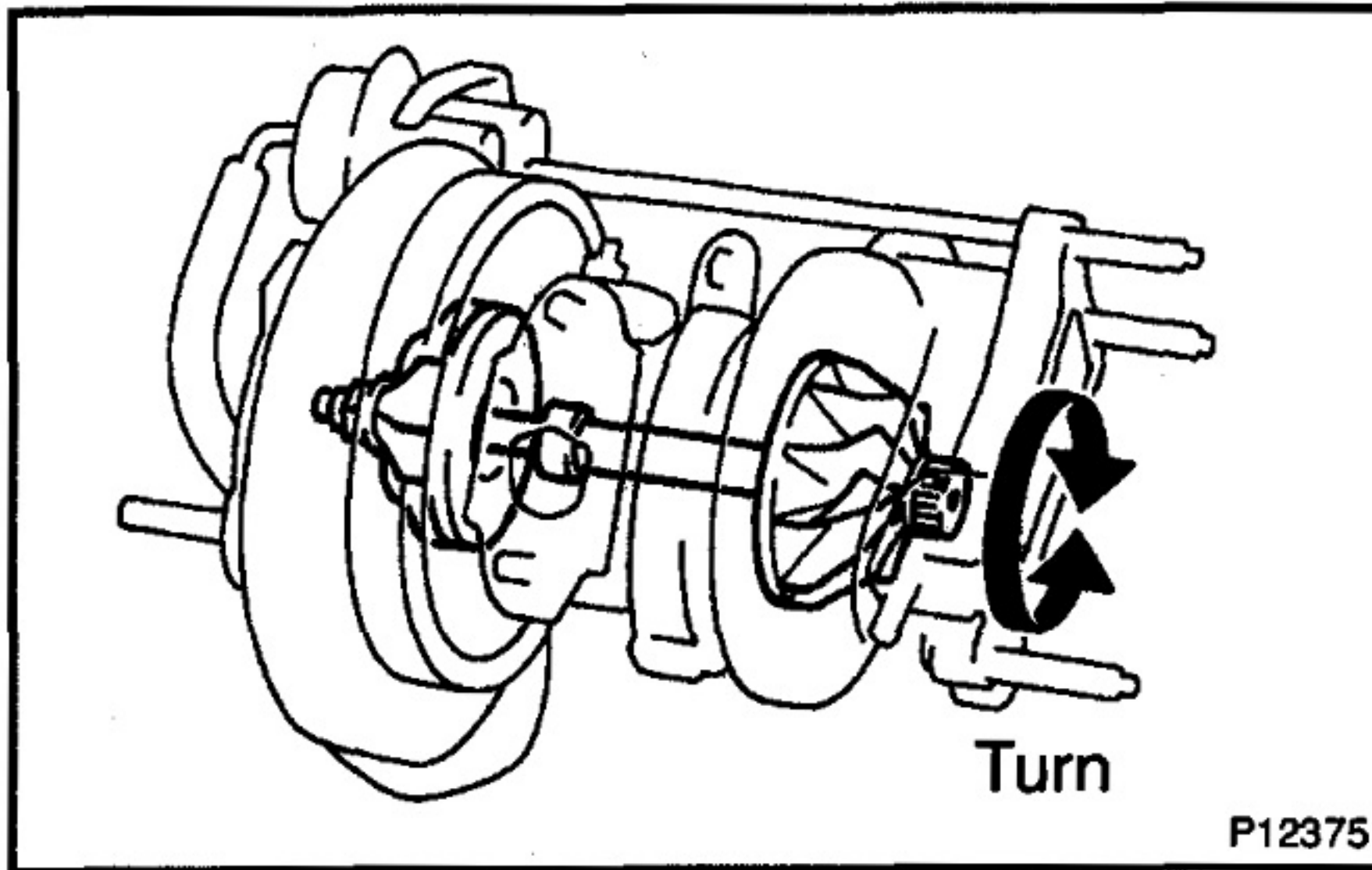

DISASSEMBLY

1. INSPECT TURBINE SHAFT ROTATION

Grasp the edge of the turbine shaft, and turn it. Check that the turbine shaft turns smoothly.

If the turbine shaft does not turn or if it turns with a heavy drag, replace the turbocharger.

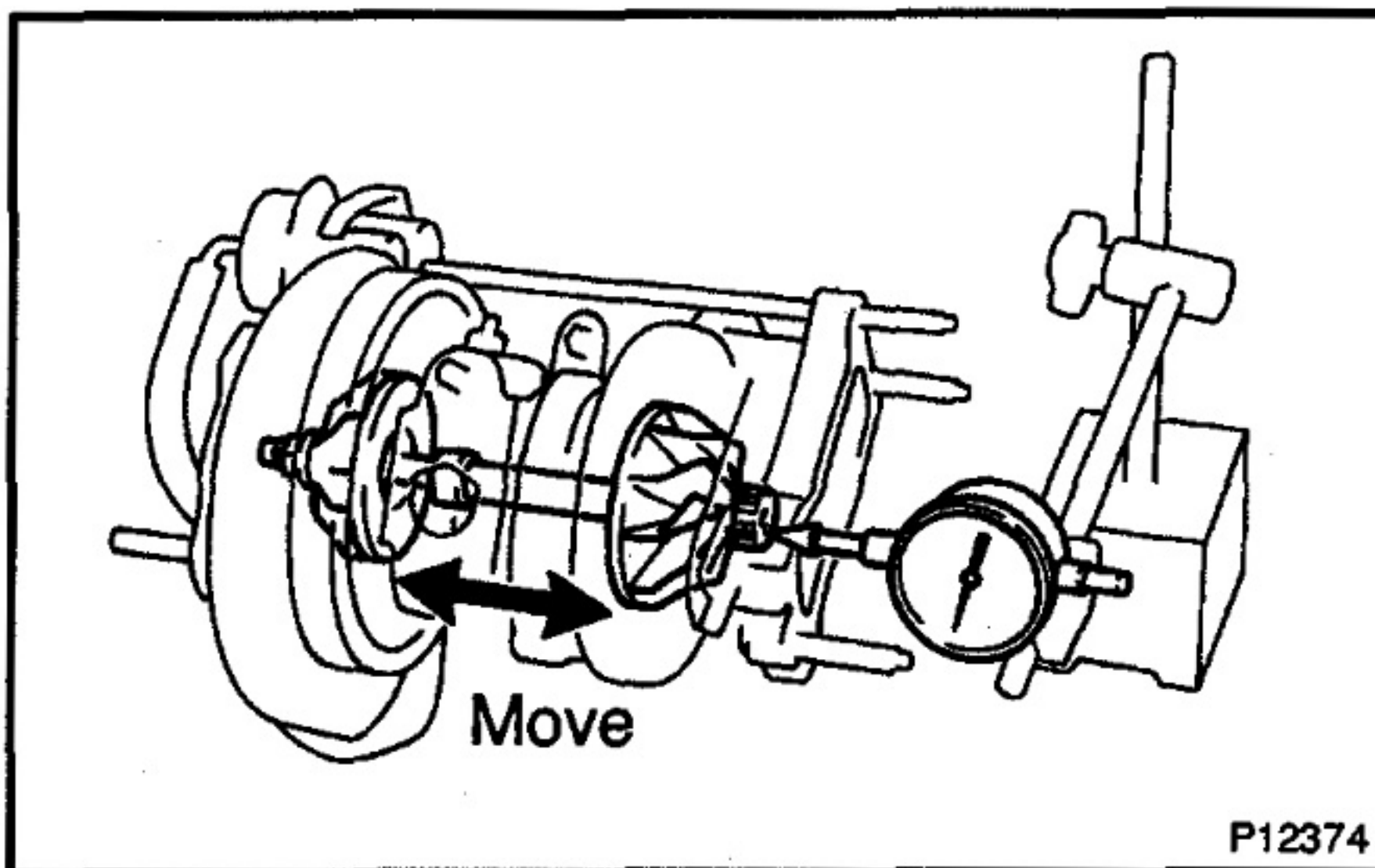

2. INSPECT AXIAL PLAY OF TURBINE SHAFT

(a) Using a dial indicator, insert the needle of the dial indicator into the exhaust side.

(b) Move the turbine shaft in an axial direction, measure the axial play of the turbine shaft.

Maximum axial play: 0.15 mm (0.0063 in.)

If the axial play is greater than maximum, replace the turbocharger.

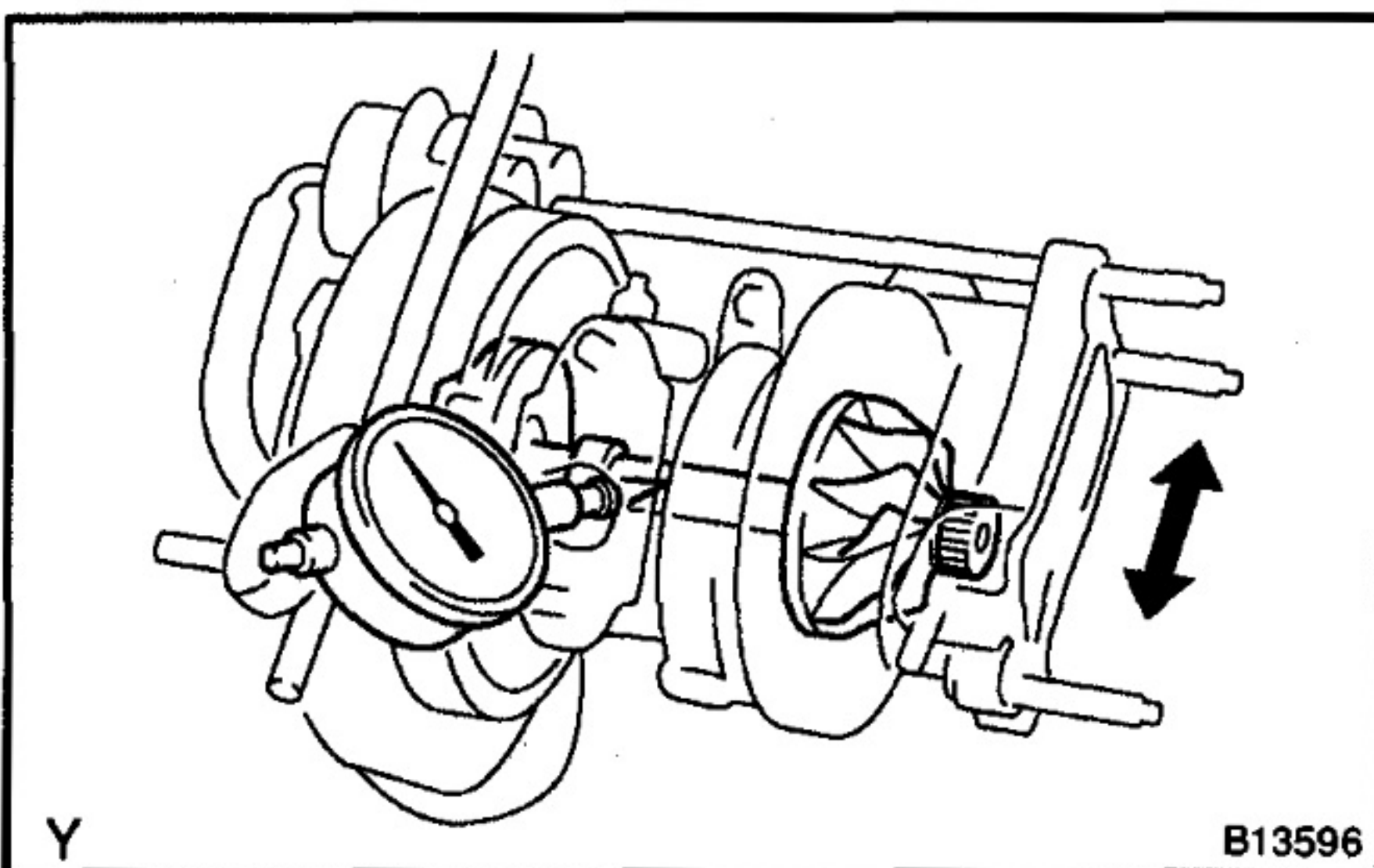

3. INSPECT RADIAL PLAY OF TURBINE SHAFT

(a) Using a dial indicator, insert the needle of the dial indicator into the oil outlet hole, and set it in the center of the turbine shaft.

(b) Move the turbine shaft in a radial direction, measure the radial play of the turbine shaft.

Maximum radial play: 0.11 mm (0.0043 in.)

If the radial play is greater than maximum, replace the turbocharger.

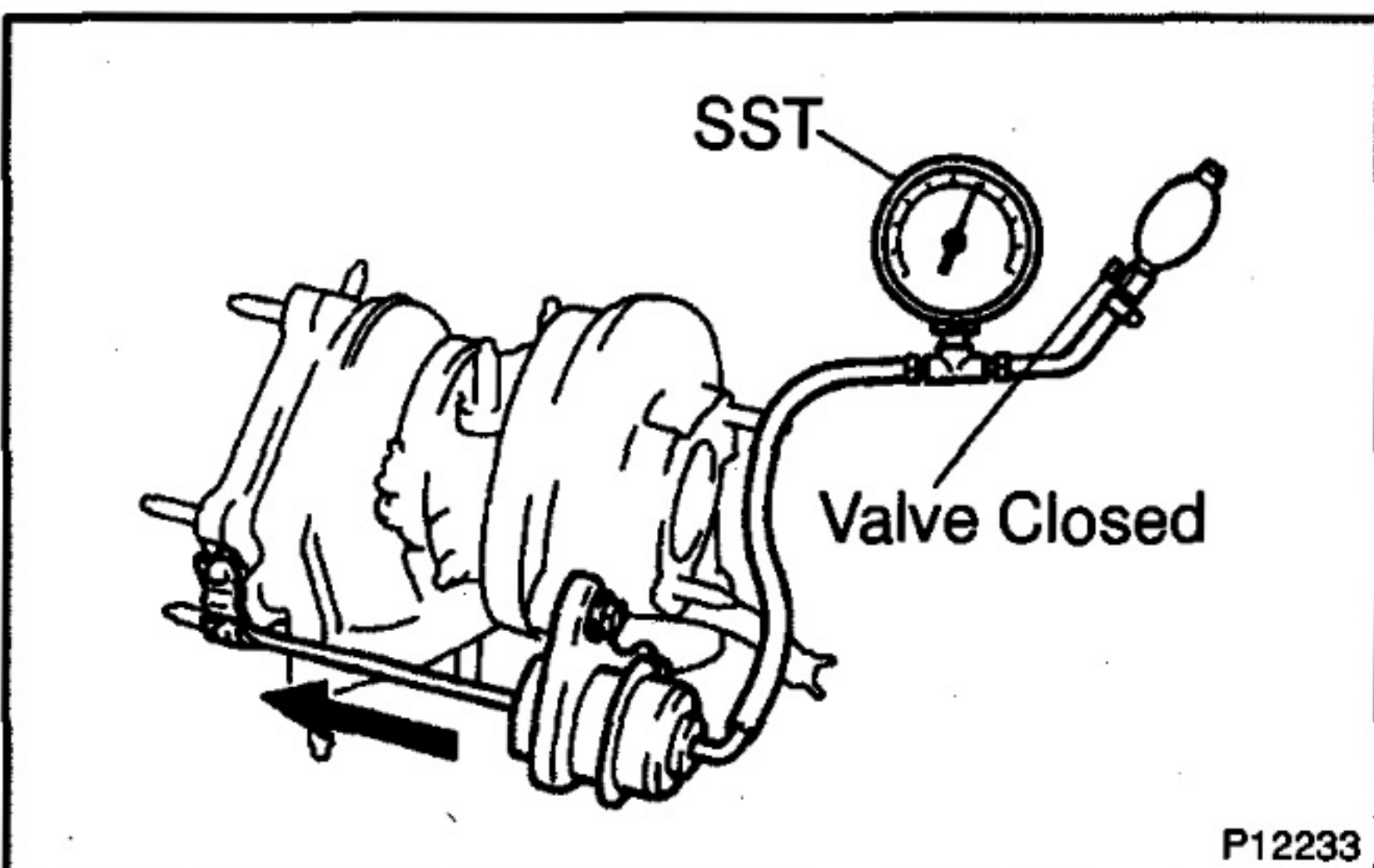

4. INSPECT ACTUATOR AND WASTE GATE VALVE OPERATION

(a) Disconnect the actuator hose from the compressor housing.

(b) Using SST, apply approx. 111 kPa (1.13 kgf/cm², 15.9 psi) of pressure to the actuator.

SST 09992-00242

(c) Move the actuator push rod, and check that the waste gate valve is open.

If the rod does not move, replace the actuator or turbocharger.

NOTICE:

Never apply more than 147 kPa (1.50 kgf/cm², 21.3 psi) of pressure to the actuator.

(d) Reconnect the actuator hose to the compressor housing.

5. REMOVE BEARING HOUSING SIDE PLATE FROM TURBOCHARGER

Remove the 2 bolts, side plate and gasket.

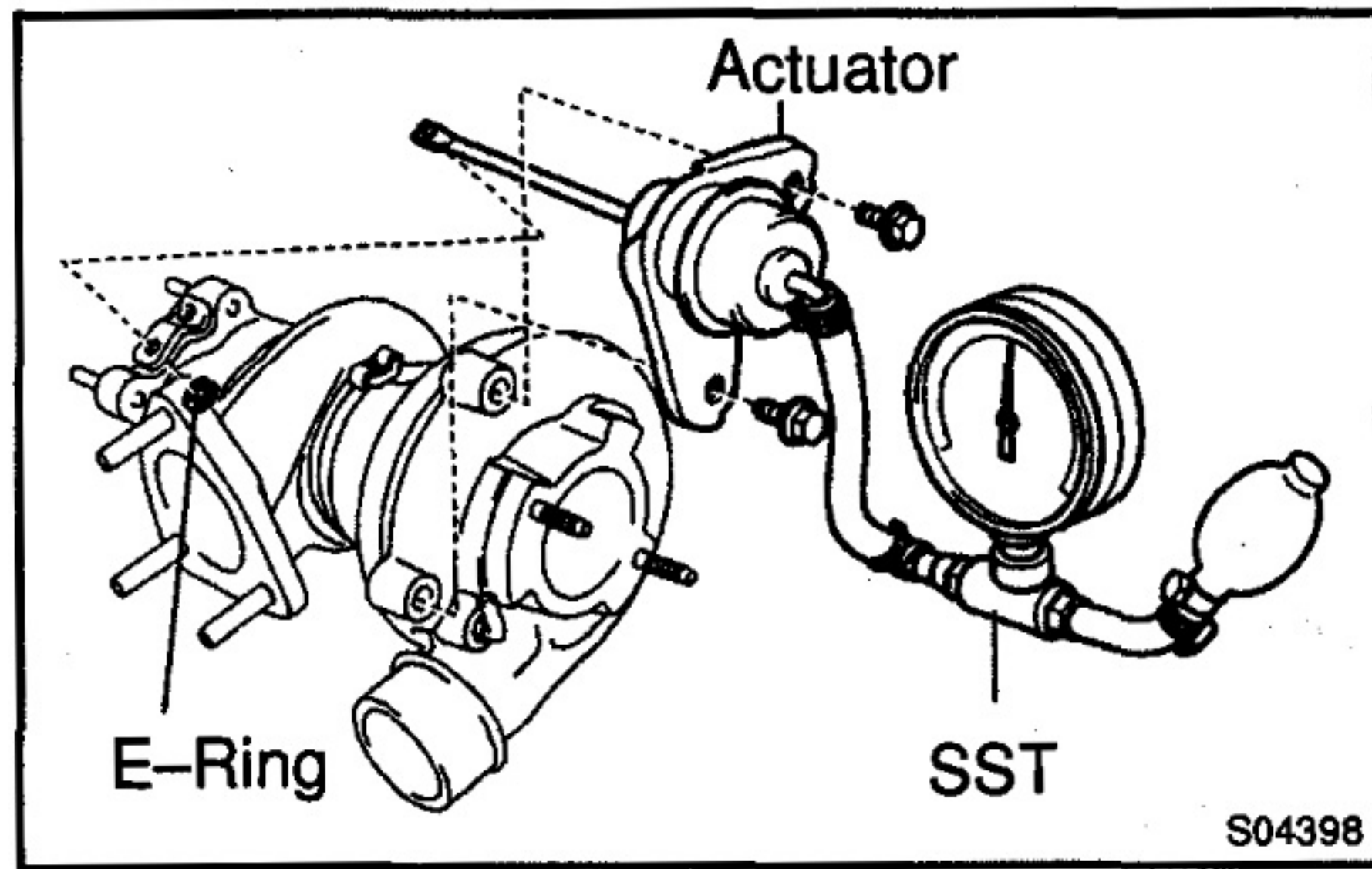

6. REMOVE ACTUATOR

- (a) Disconnect the actuator hose from the compressor housing.
- (b) Using SST, apply pressure to the actuator.
SST 09992-00242

NOTICE:

Never apply more than 147 kPa (1.50 kgf/cm², 21.3 psi) of pressure to the actuator.

- (c) Remove the 2 bolts holding the actuator to the compressor housing.
- (d) Remove the E-ring holding the actuator push rod to the waste gate valve link, and remove the actuator.

7. REMOVE COMPRESSOR HOUSING

- (a) Place the matchmarks on the compressor housing and bearing housing.

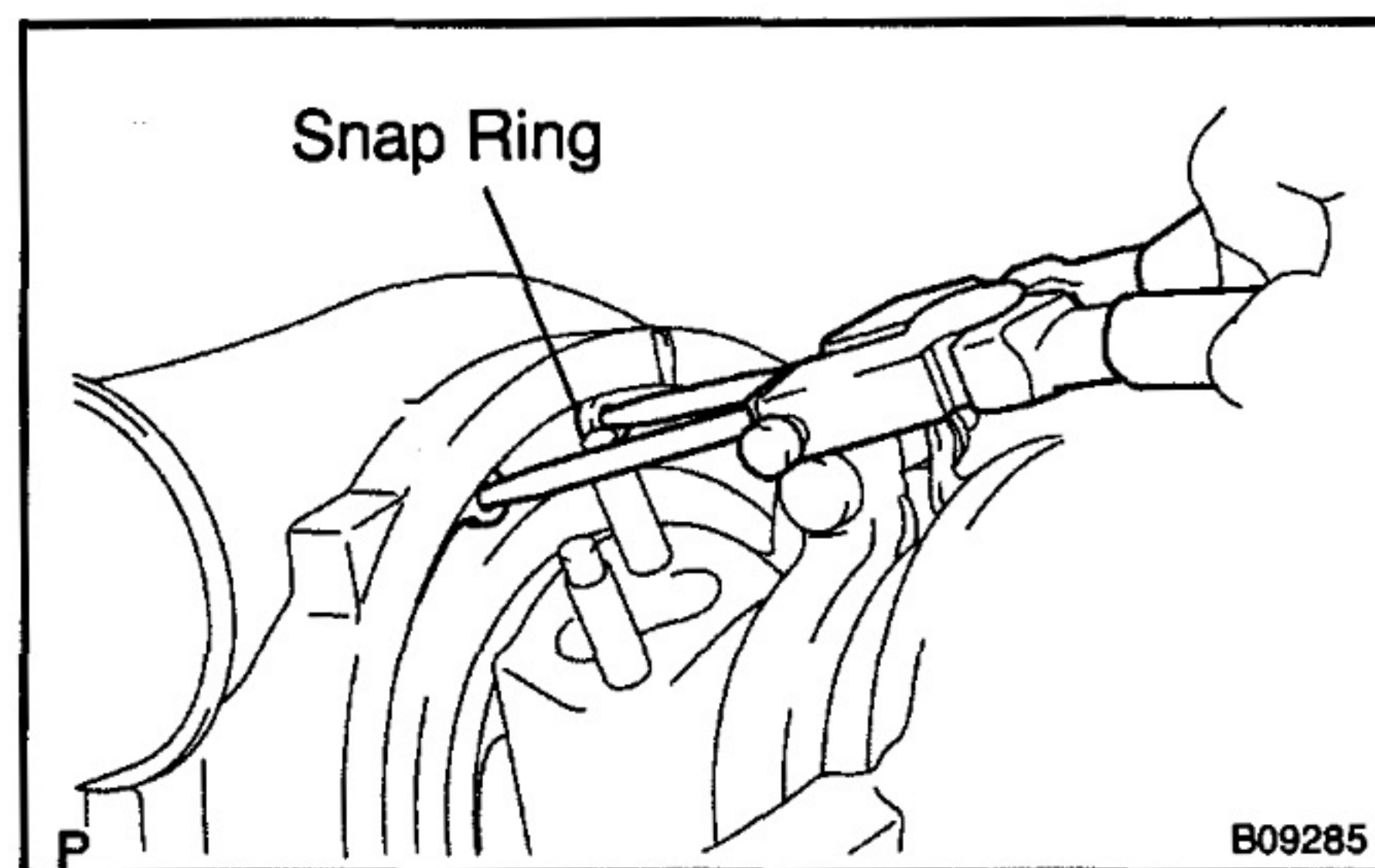

- (b) Using snap ring pliers, remove the snap ring from the compressor housing.

HINT:

Do not remove the snap ring with force from the turbocharger.

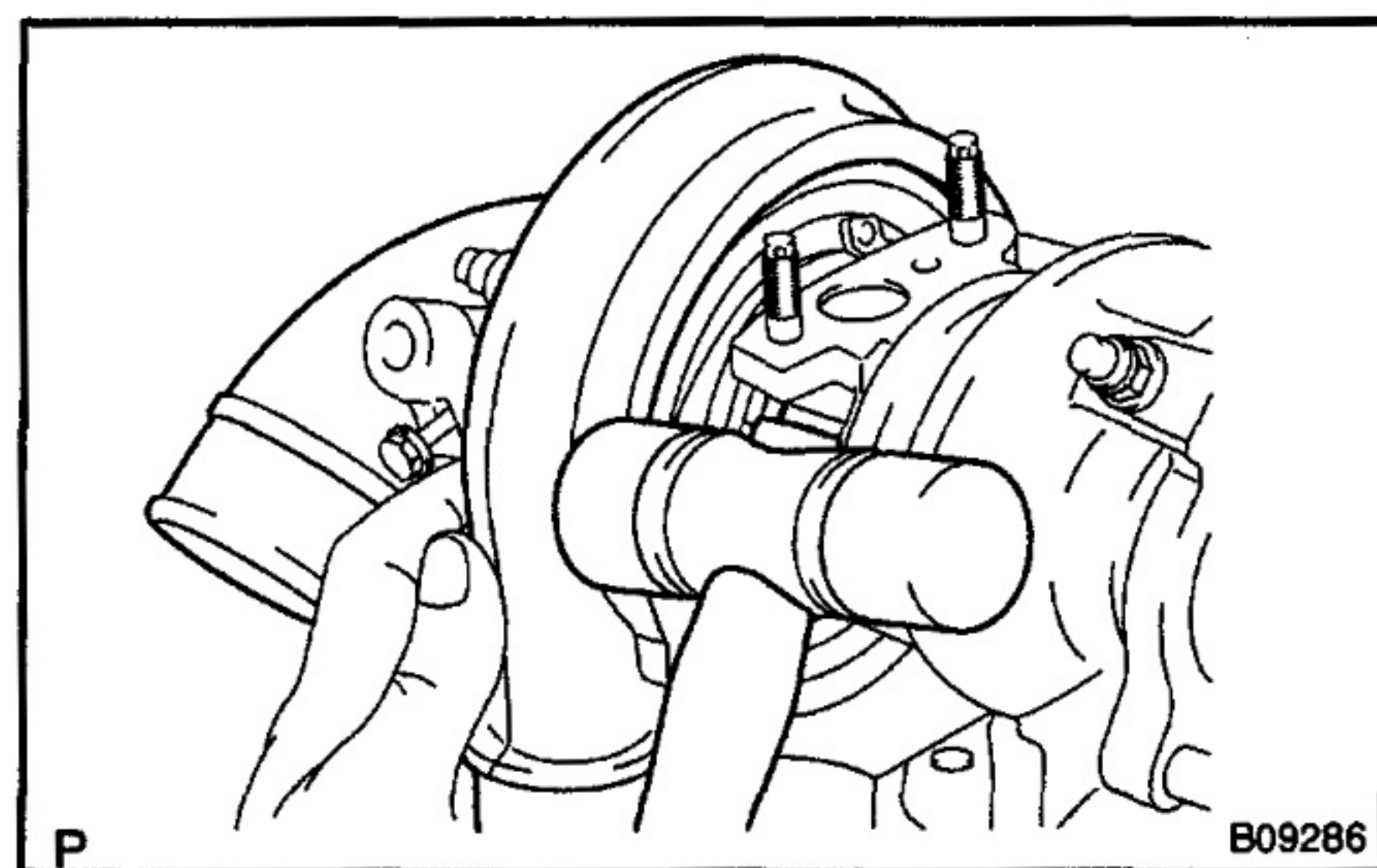

- (c) Using a plastic-faced hammer, tap out the compressor housing.

NOTICE:

Remove the compressor housing as straight as possible and do not make the impeller wheel interfere with the compressor housing.

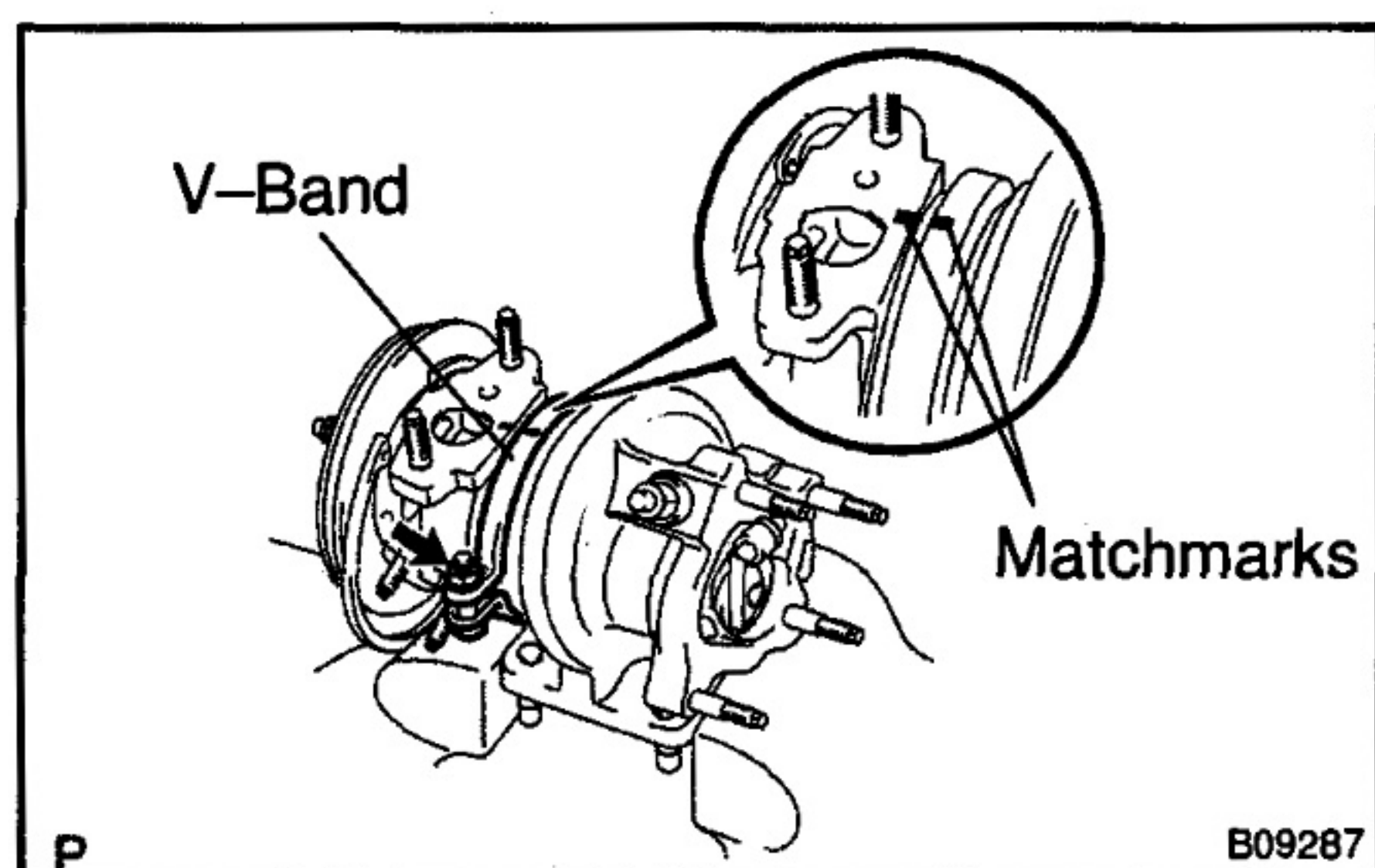

8. REMOVE BEARING HOUSING

- (a) Place the matchmarks on the V-band, turbine housing and bearing housing.
- (b) Remove the nut and V-band.

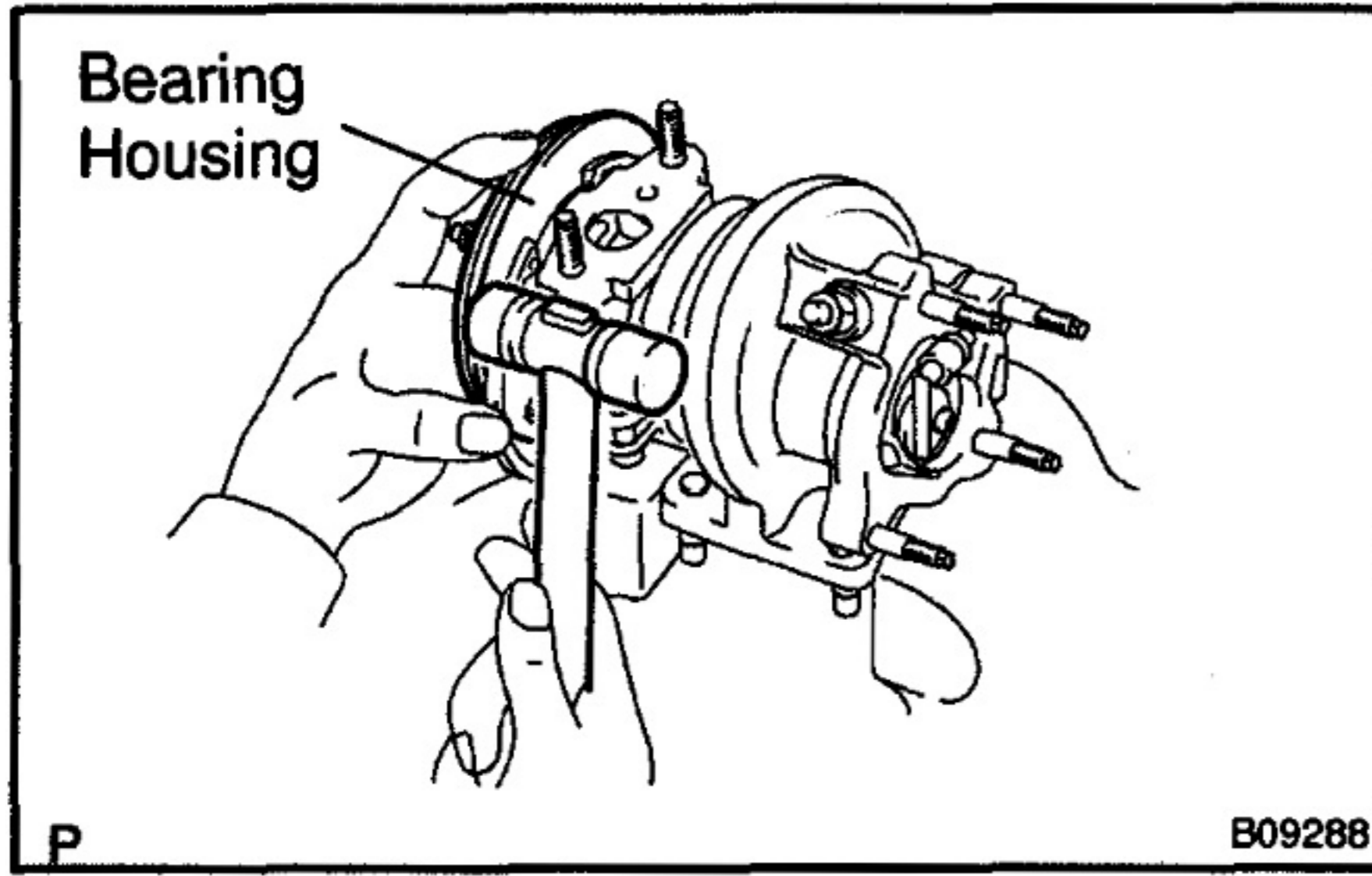

- (c) Using a plastic-faced hammer, tap out the bearing housing.

NOTICE:

Remove the bearing housing as straight as possible and so not make the turbine wheel interfere with the turbine housing.

- (d) Remove the snap ring from the turbocharger.
(e) Remove the O-ring from the bearing housing.

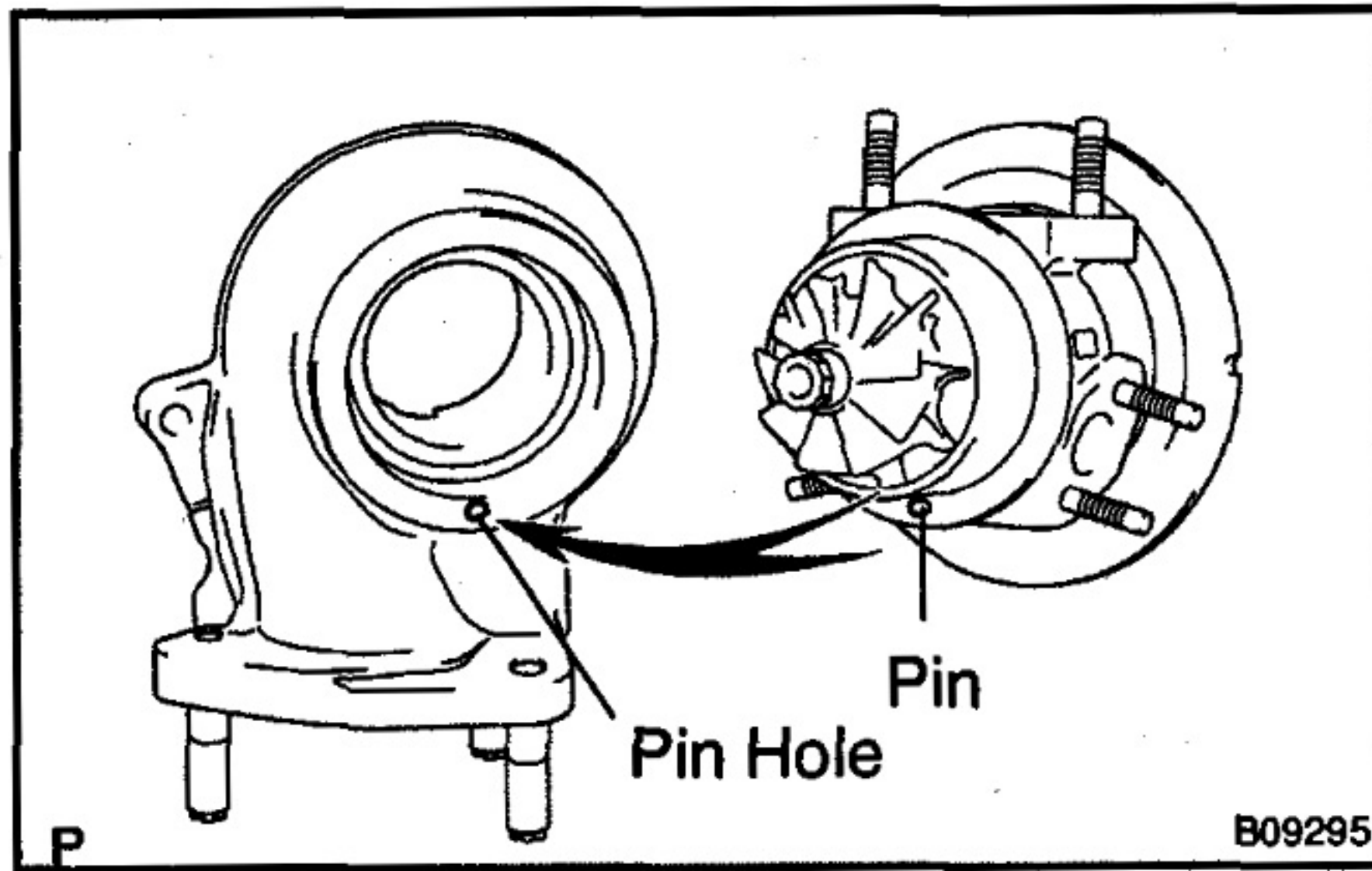

REASSEMBLY

1. INSTALL BEARING HOUSING

- (a) Install the snap ring to the turbocharger.

HINT:

In advance, put the snap ring through the bearing housing.

- (b) Install a new O-ring to the bearing housing.
 (c) Align the pin of the turbine housing with the pin hole of the bearing housing.

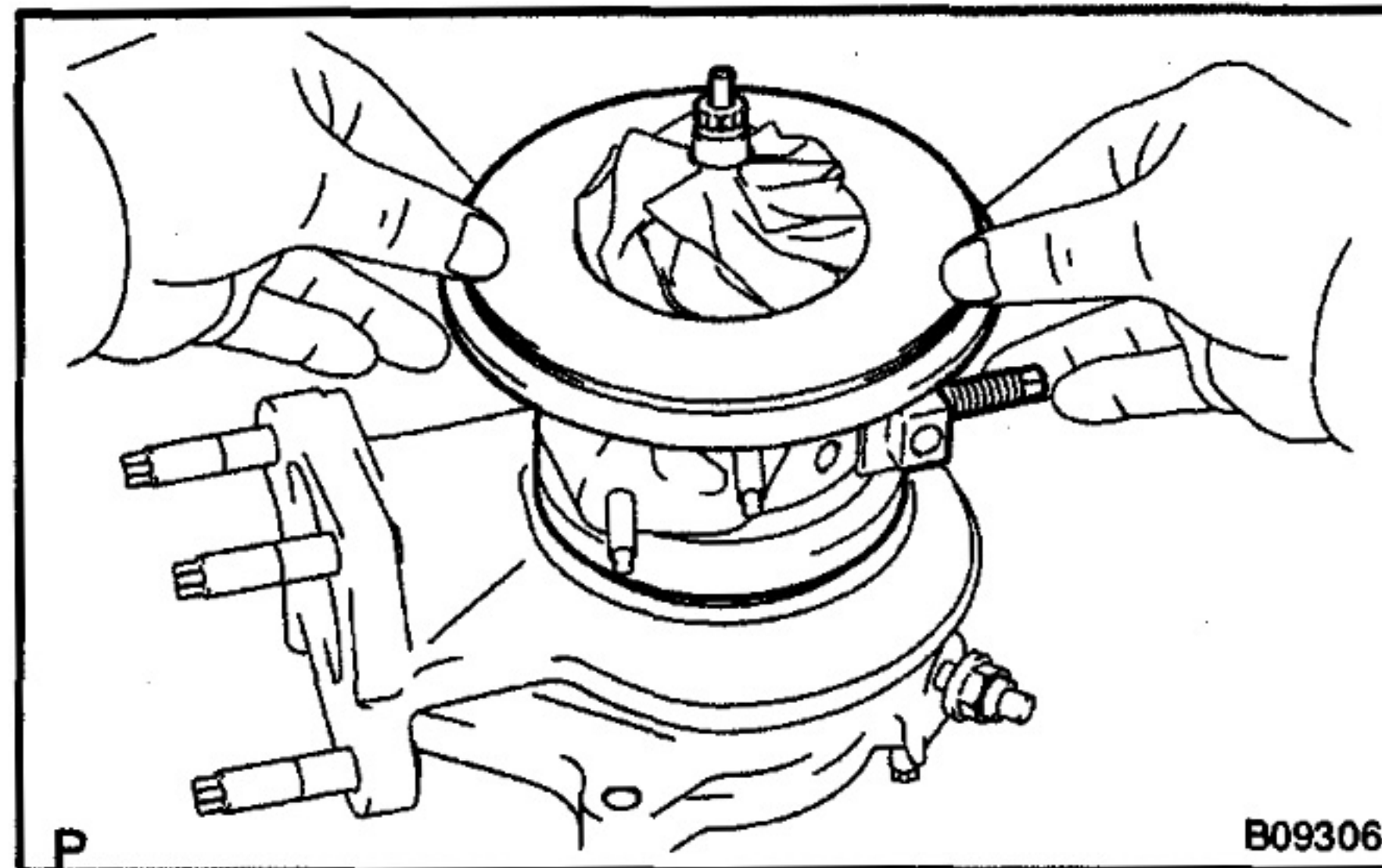

- (d) Install the bearing housing to the turbine housing.

NOTICE:

- Install the bearing housing straight, and be careful not to damage the turbine wheel.
- In case of having difficulty of pressing in the bearing housing to install with a hand due to hard engagement, apply the procedure (c).

HINT:

Apply a little penetrate rust prevention lubricant onto the engagement section to make installation easier.

- (e) In case that the engagement of the bearing housing is hard, using SST and a press, install the bearing housing while checking the smooth rotation of the impeller wheel.
 SST 09350-32014 (09351-32070)

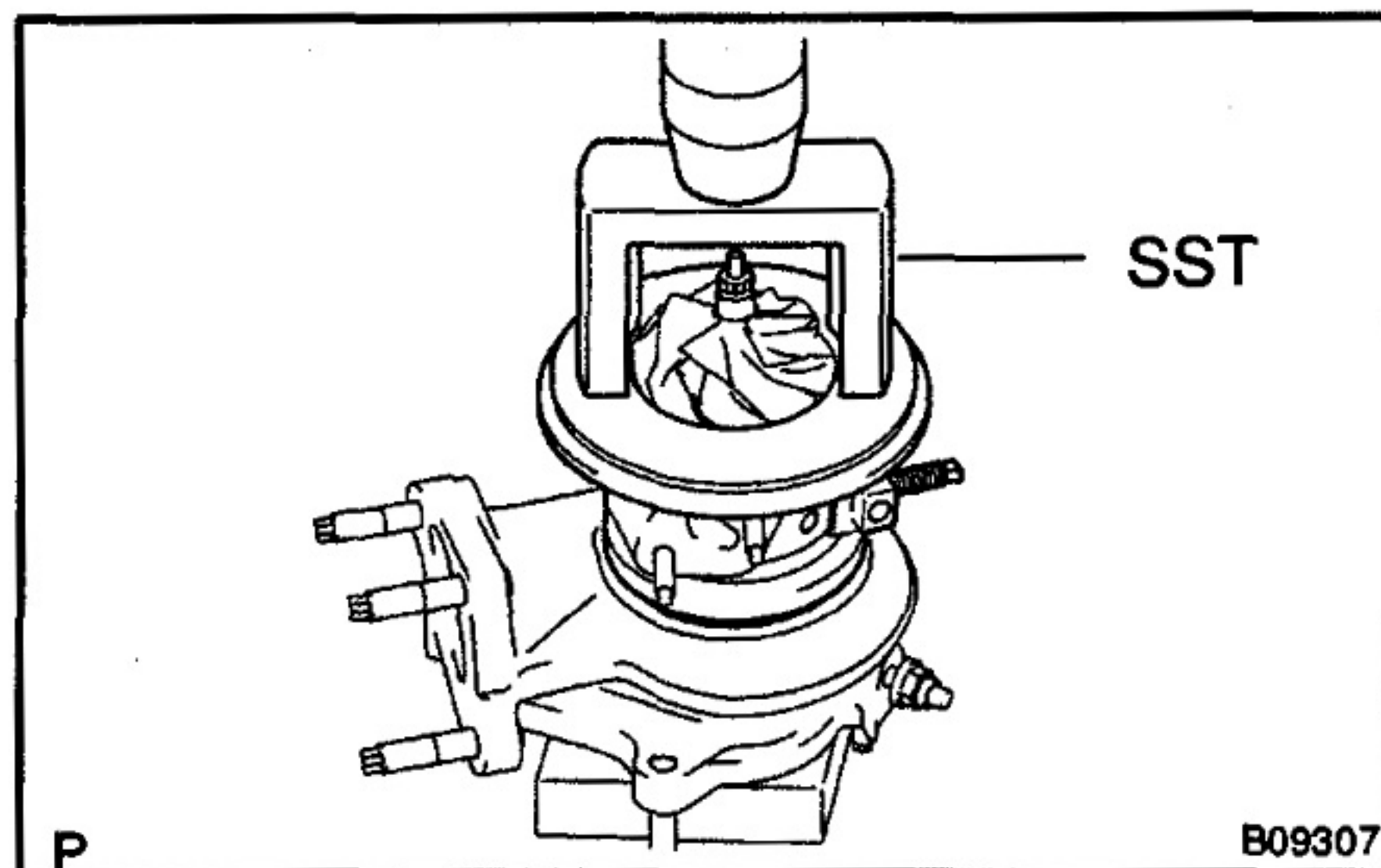

NOTICE:

- Do not hold the turbine housing with the stud bolts.
- Be sure to install the bearing housing straight without tilting as the shaft may bent and cause the irregular noise.
- Press in the bearing housing slowly. When the rotation of the impeller wheel becomes heavy, return the press immediately and do the operation again.
- After installed, check that the turbine shaft turns smoothly.

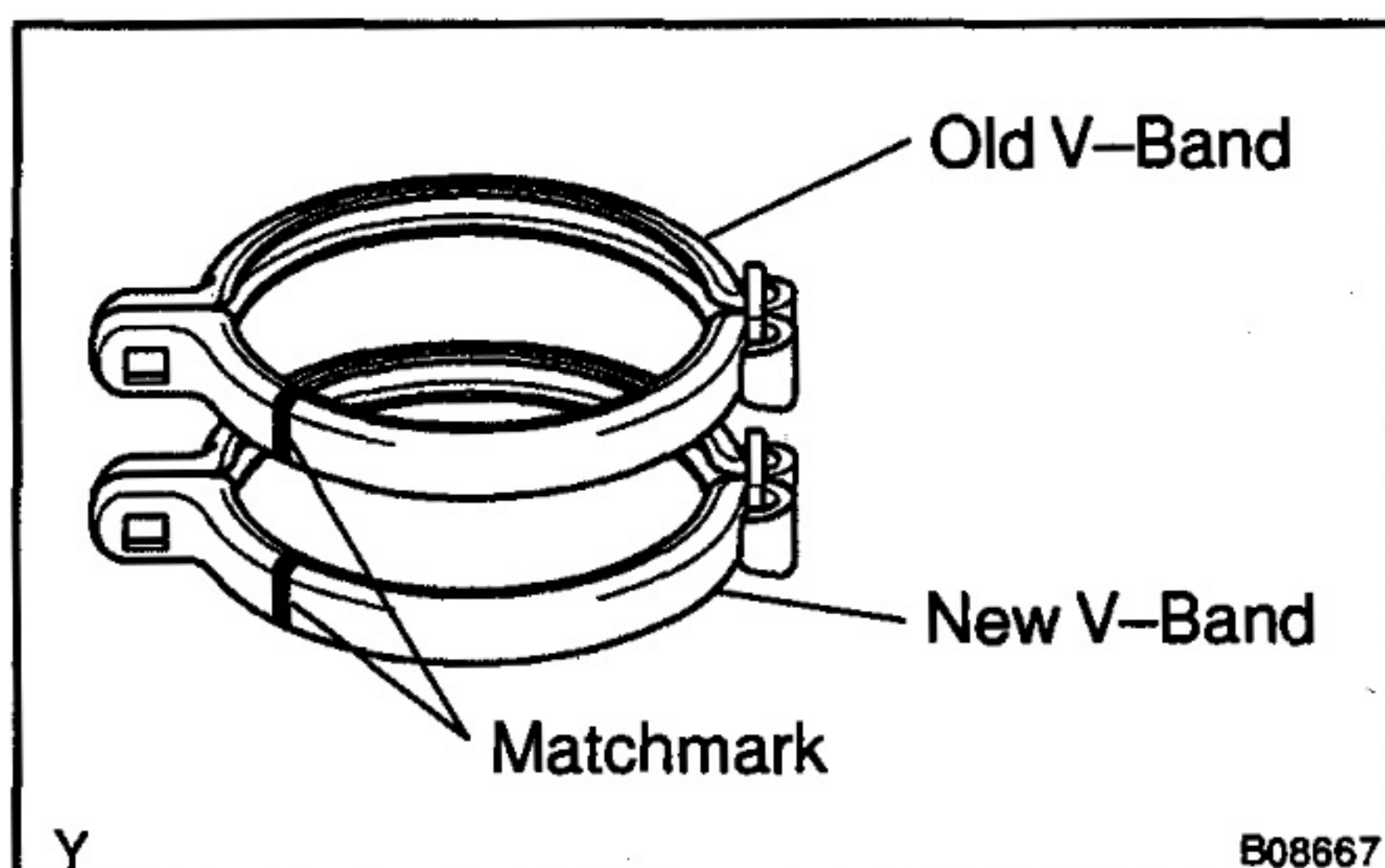

- (f) Place a new and old (used) V-bands in line, then reprint the matchmark position on the old V-band to the new one.

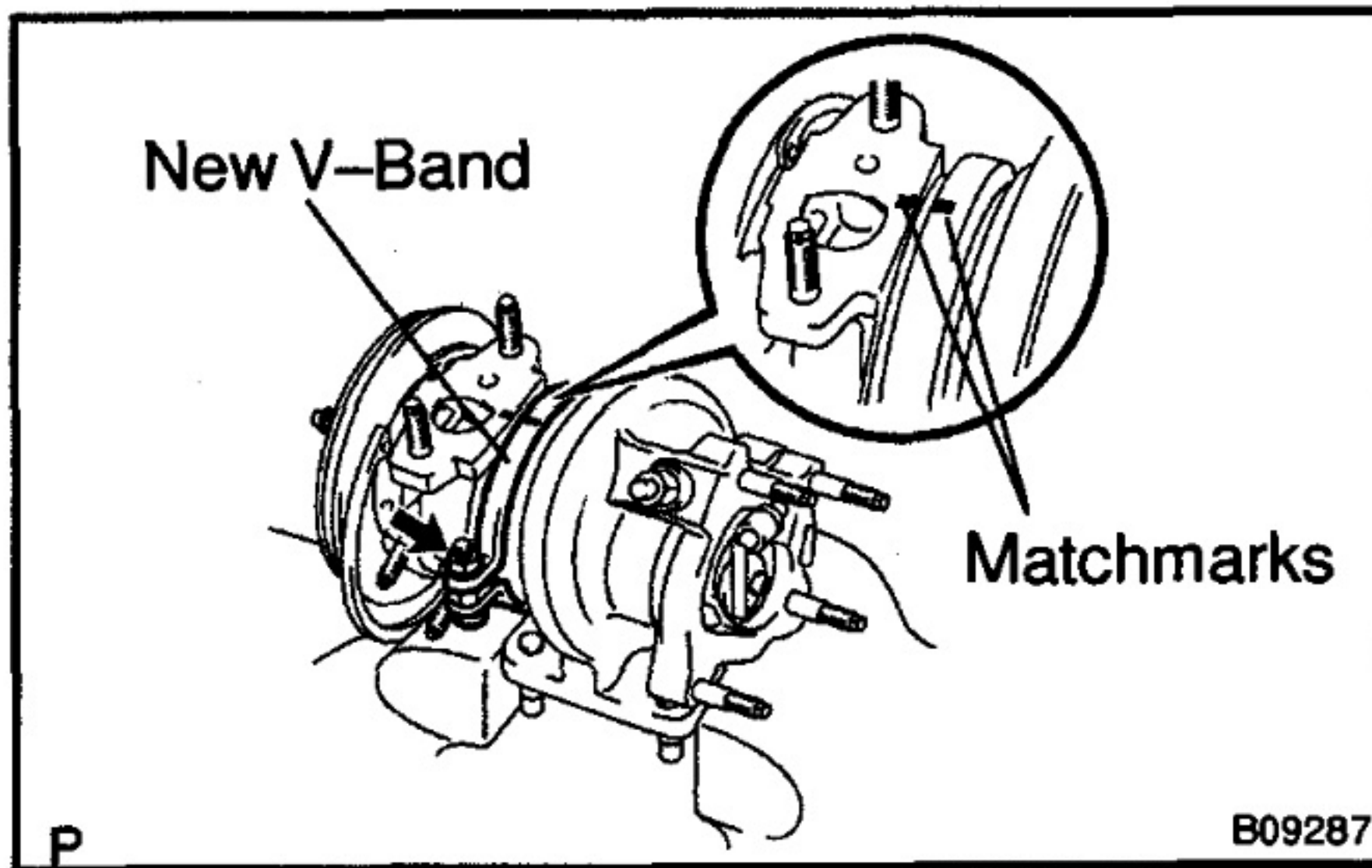

- (g) Align the matchmarks on the V-band, turbine housing and bearing housing, and temporarily tighten a new nut.
Torque: 4.8 N·m (49 kgf·cm, 42 in.-lbf)

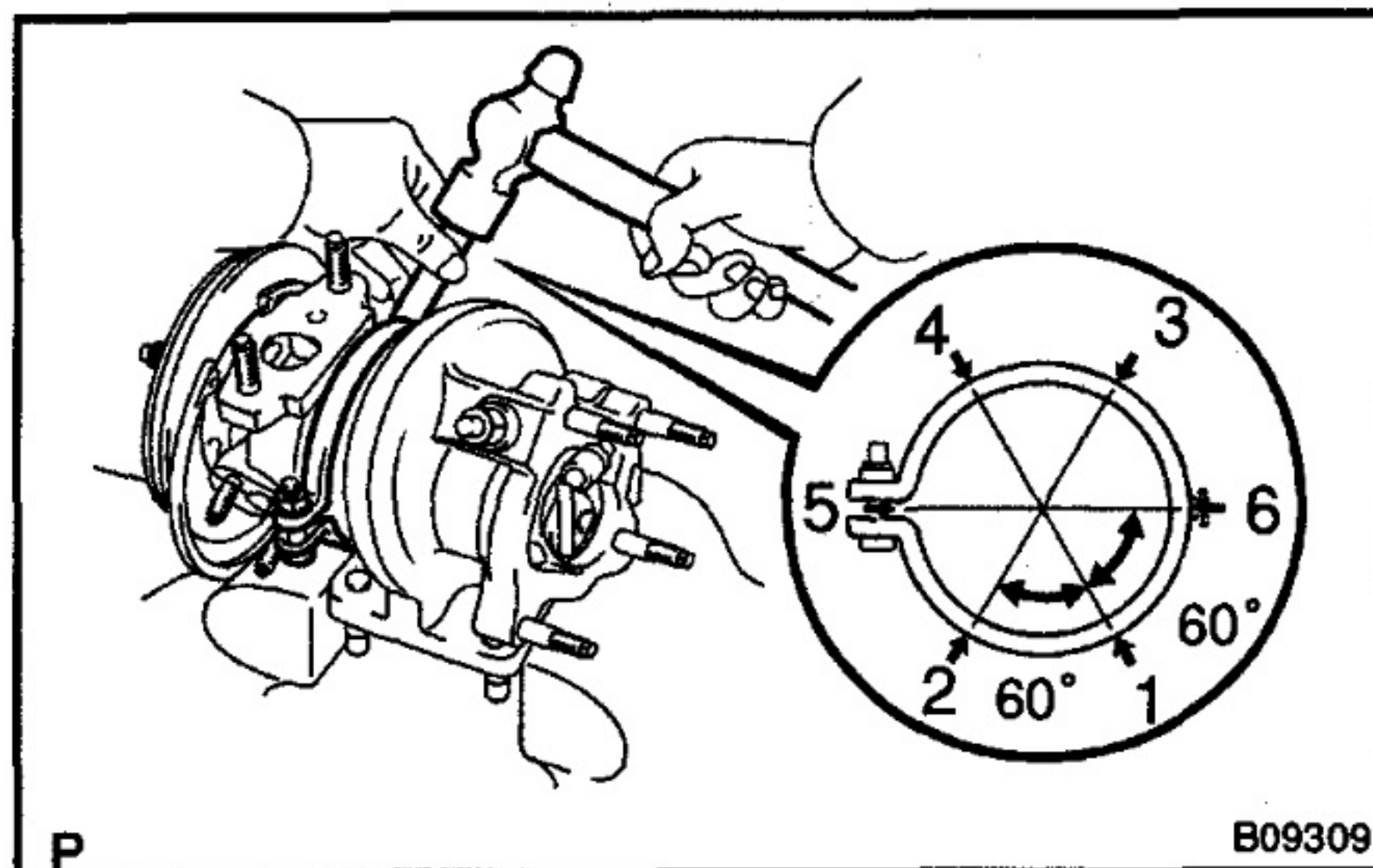

- (h) Using a brass bar and hammer, hit 2 or 3 times lightly at each place in order of 1 through 5.
(i) Tighten the nut more.
Torque: 4.8 N·m (49 kgf·cm, 42 in.-lbf)
(j) Using a brass bar and hammer, hit 2 or 3 times lightly at each place of 1 and 4.
(k) Tighten the nut completely.

TC

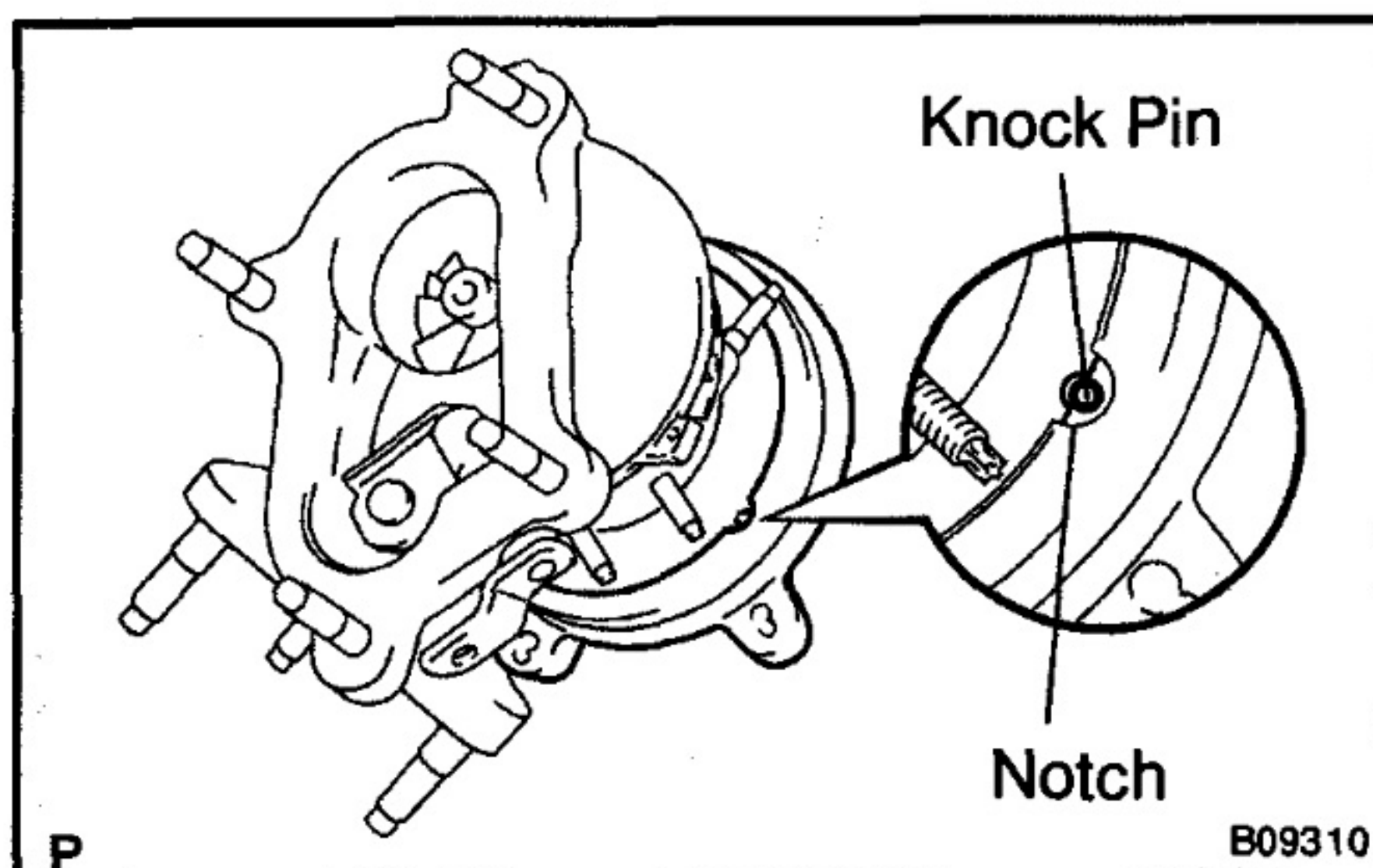

2. INSTALL COMPRESSOR HOUSING

- (a) Align the knock pin of the bearing housing with the notch of the compressor housing, and install them.

NOTICE:

- Do not make the impeller wheel interfere with the compressor housing.
- Check that the turbine shaft turns smoothly.

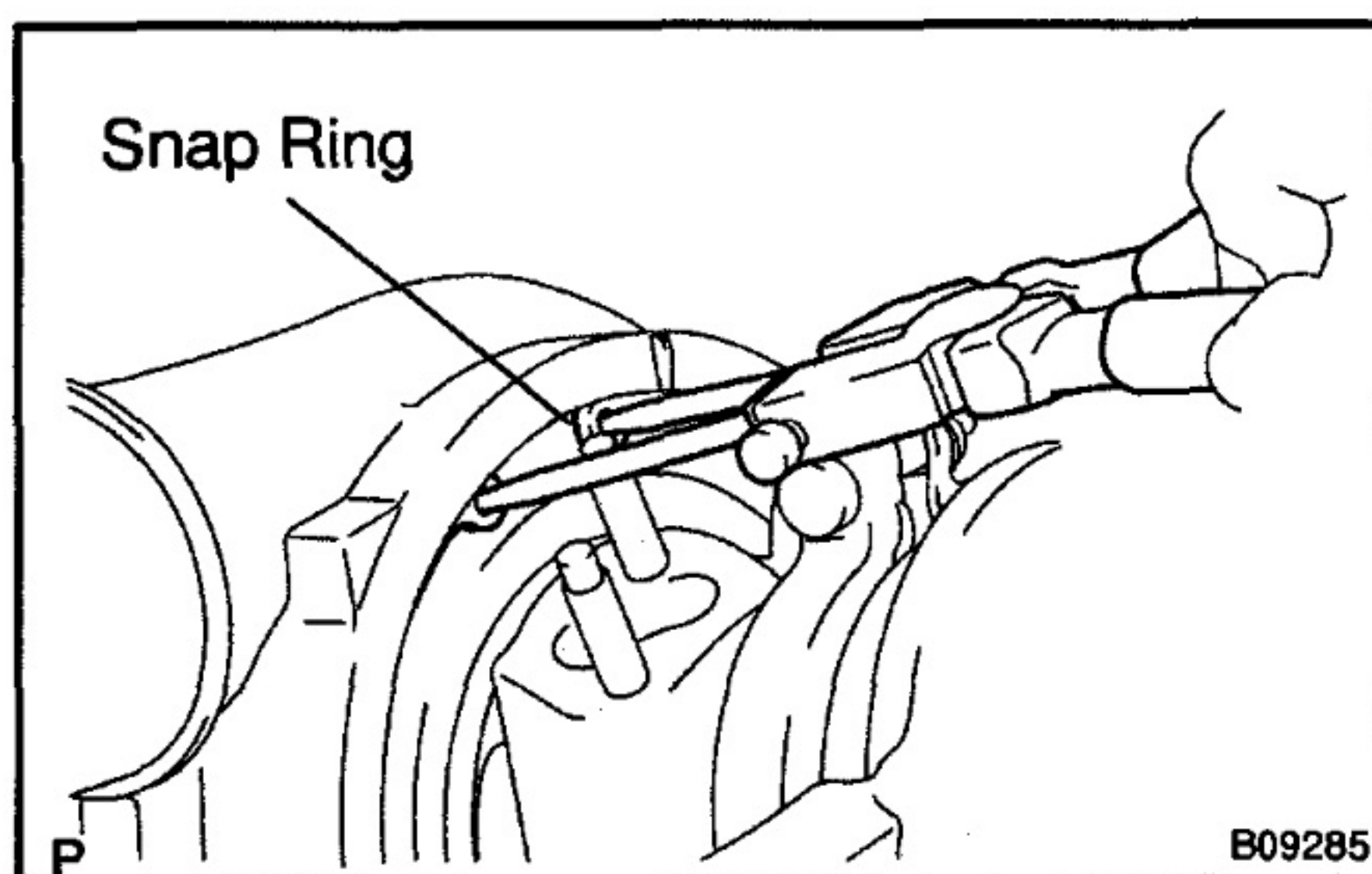

- (b) Using snap ring pliers, install the snap ring to the compressor housing.

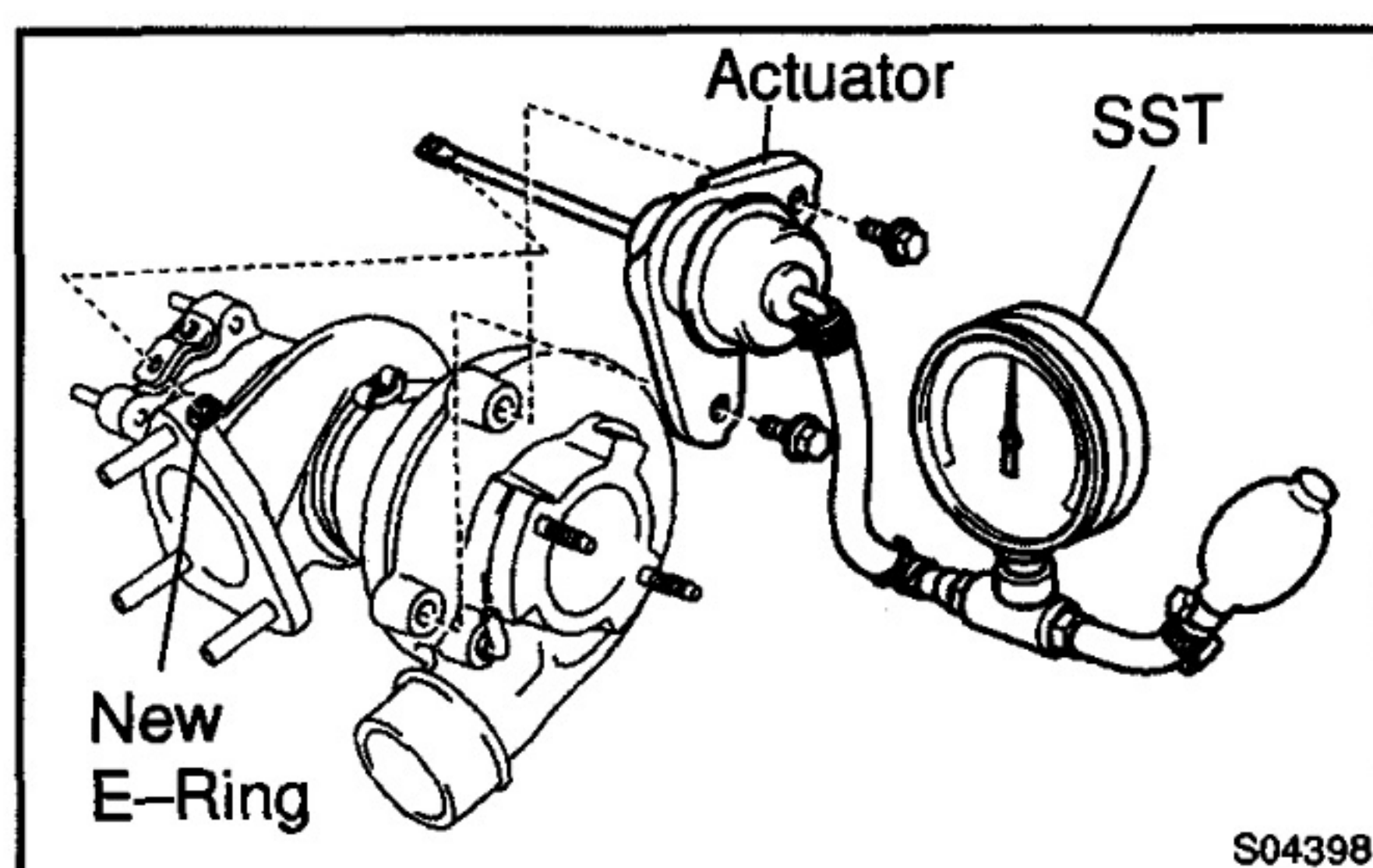

3. INSTALL ACTUATOR

- (a) Using SST, apply pressure to the actuator.
SST 09992-00241

NOTICE:

Never apply more than 147 kPa (1.50 kgf/cm², 21.3 psi) of pressure to the actuator.

- (b) Connect the actuator push rod to the waste gate valve link with a new E-ring.
(c) Install the actuator with the 2 bolts.
Torque: 19.1 N·m (195 kgf·cm, 14 ft.-lbf)

- (d) Remove the SST.

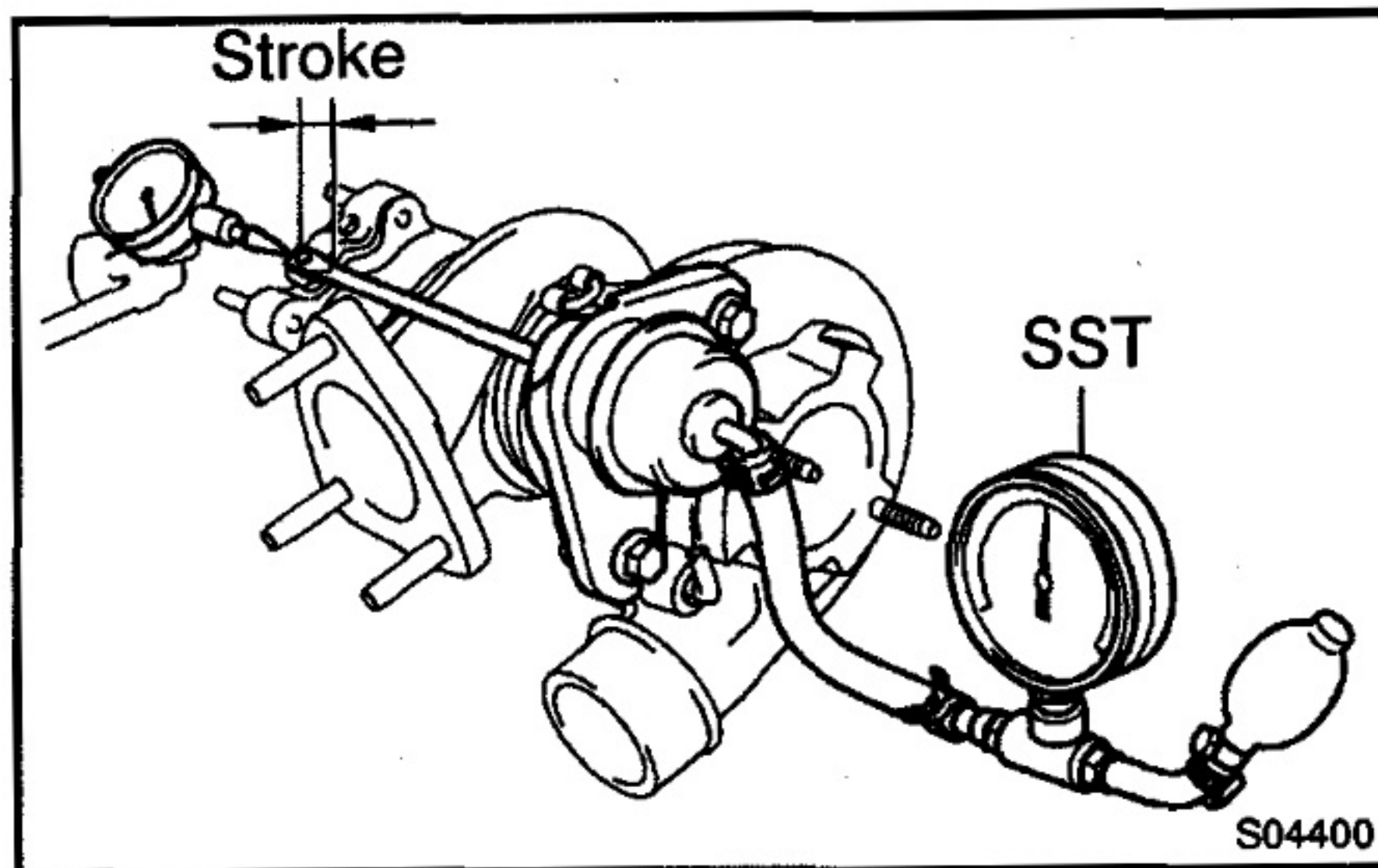

4. ADJUST ACTUATOR PUSH ROD STROKE

NOTICE:

Never apply more than 147 kPa (1.50 kgf/cm², 21.3 psi) of pressure to the actuator.

- Using a dial indicator, set the dial indicator in a straight line with the actuator push rod.
- Using SST, apply 119 kPa (1.21 kgf/cm², 17.2 psi) of pressure to the actuator, and measure the actuator push rod stroke.

SST 09992-00242

- From the table below select the plate washer thickness to match the stroke measured in (b) above.

Stroke measurement mm (in.)	Required plate washer thickness mm (in.)
1.20 - 1.70 (0.0472 - 0.0669)	None required
1.71 - 2.20 (0.0673 - 0.0866)	0.5 (0.020)
2.21 - 2.70 (0.0870 - 0.1063)	1.0 (0.039)
2.71 - 3.20 (0.1067 - 0.1260)	1.5 (0.059)
3.21 - 3.70 (0.1264 - 0.1457)	2.0 (0.079)
3.71 - 4.20 (0.1461 - 0.1654)	2.5 (0.098)
4.21 - 4.70 (0.1657 - 0.1850)	3.0 (0.118)
4.71 - 5.20 (0.1854 - 0.2047)	3.5 (0.138)
5.21 - 5.70 (0.2051 - 0.2244)	4.0 (0.157)
5.71 - 6.20 (0.2248 - 0.2441)	4.5 (0.177)
6.21 - 6.70 (0.2445 - 0.2638)	5.0 (0.197)
6.71 - 7.20 (0.2642 - 0.2827)	5.5 (0.217)
7.21 - 7.70 (0.2839 - 0.3031)	6.0 (0.236)
7.71 - 8.20 (0.3035 - 0.3228)	6.5 (0.256)

NOTICE:

- Use a combination of plate washers of 0.5 mm (0.020 in.), 1.0 mm (0.039 in.), 2.0 mm (0.079 in.) and 3.0 mm (0.118 in.) thickness to achieve the required thickness.
- Use the same thickness of plate washer for the 2 locations between the actuator and compressor housing.
- If the plate washer thickness exceeds 3.5 mm (0.138 in.), replace the actuator installation bolts with the bolts from the kit part.

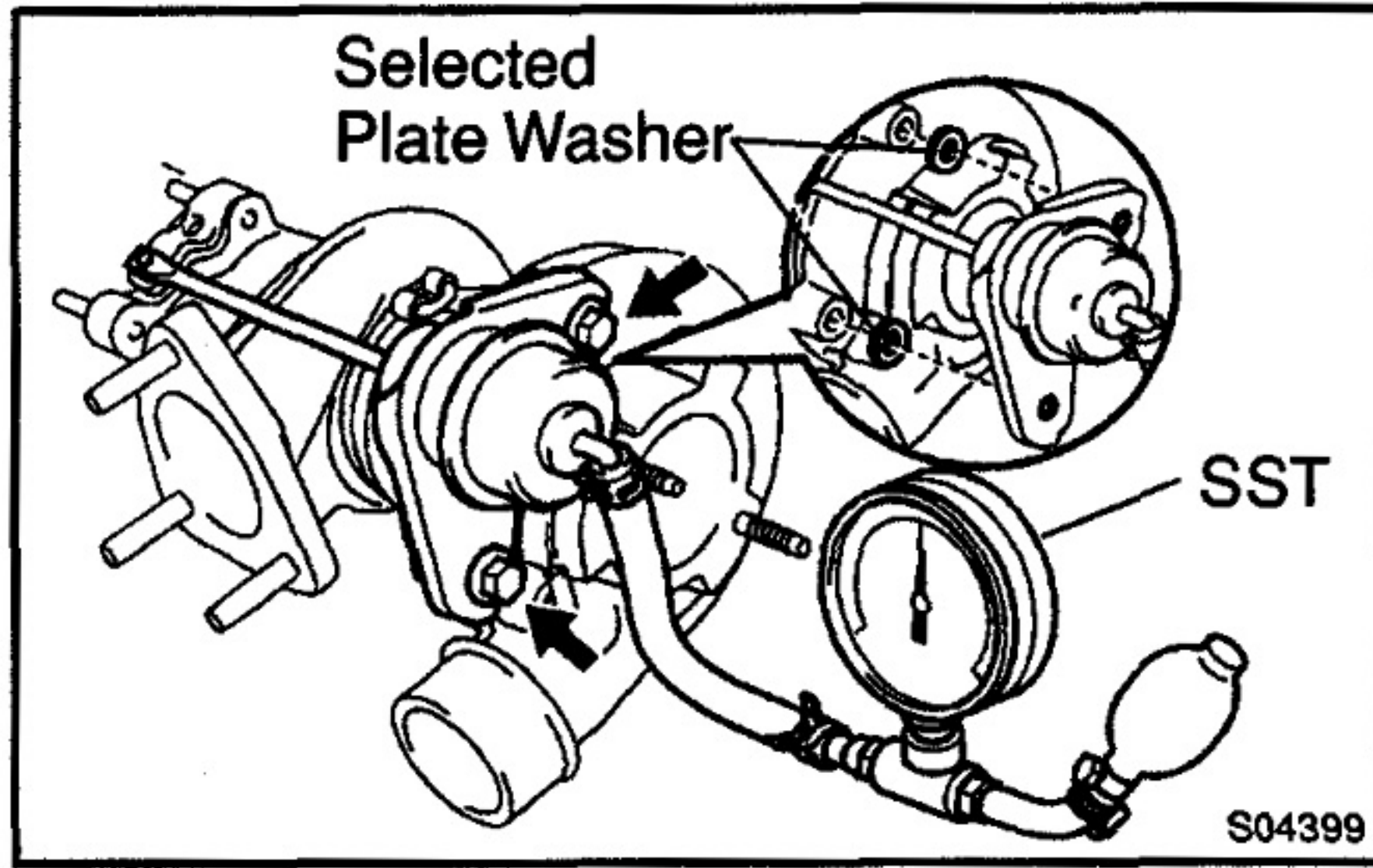

- (d) Using SST, apply approx. 119 kPa (1.21 kgf/cm², 17.2 psi) of pressure to the actuator, and install the selected plate washers between the actuator and compressor housing with the 2 bolts.

Torque: 19.1 N·m (195 kgf·cm, 14 ft·lbf)

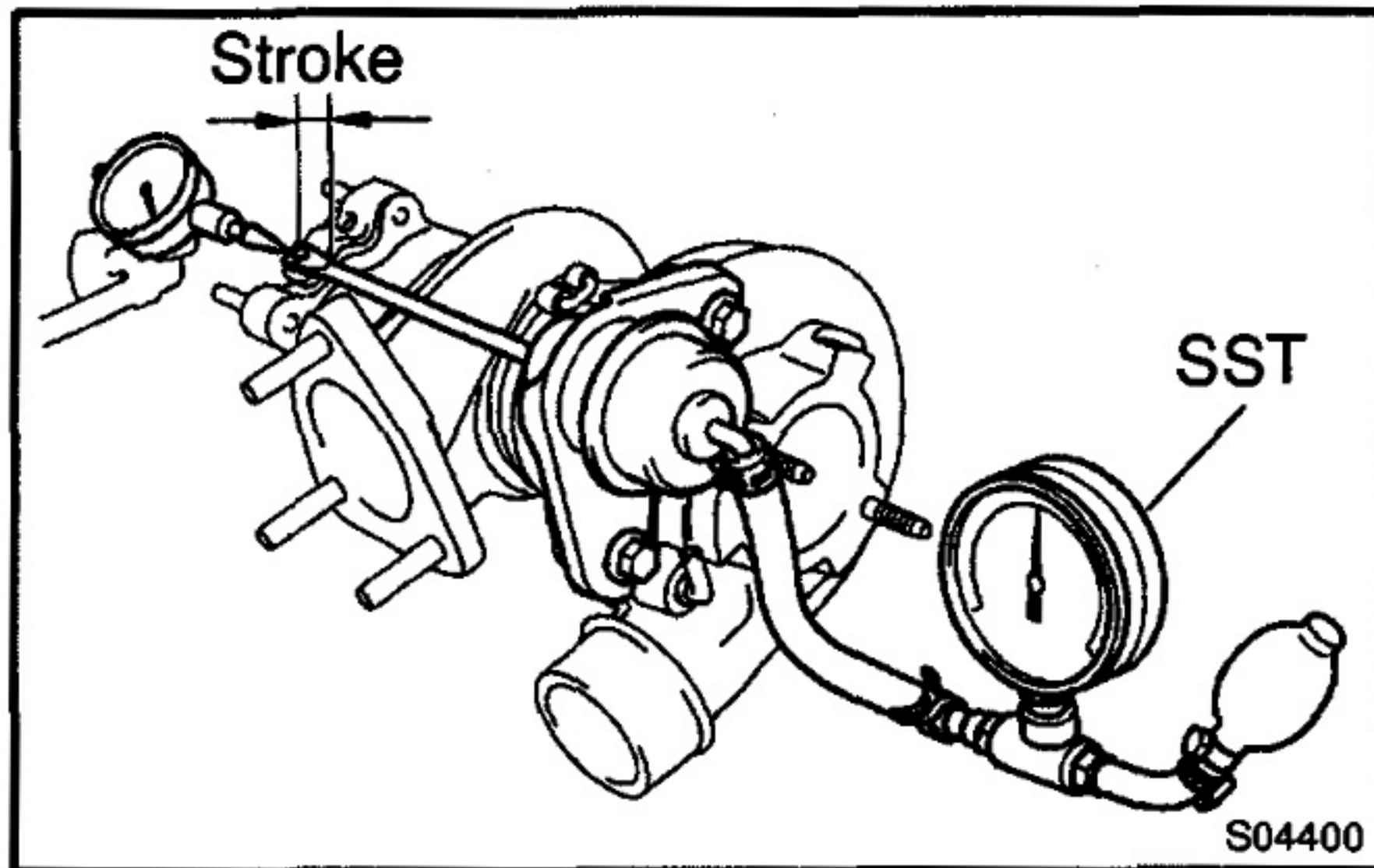

- (e) Using SST, apply approx. 113 kPa (1.13 kgf/cm², 16.1 psi) of pressure to the actuator, and measure the actuator push rod stroke.

SST 09992-00242

Standard stroke: 1.20 – 1.70 mm (0.0472 – 0.0669 in.)

If the stroke is outside specifications, reselect the plate washers.

5. INSTALL ACTUATOR HOSE

6. APPLY YELLOW PAINT

Apply yellow paint from the actuator bolts to the actuator bracket to indicate that they have been correctly installed.

7. INSTALL BEARING HOUSING SIDE PLATE TO TURBOCHARGER

Install a new gasket and the side plate with the 2 bolts.

Torque: 12 N·m (122 kgf·cm, 9ft·lbf)

INTERCOOLER COMPONENTS

TC039-01

w/ Intercooler
(Land Cruiser/Land Cruiser Prado for Australia)

TC

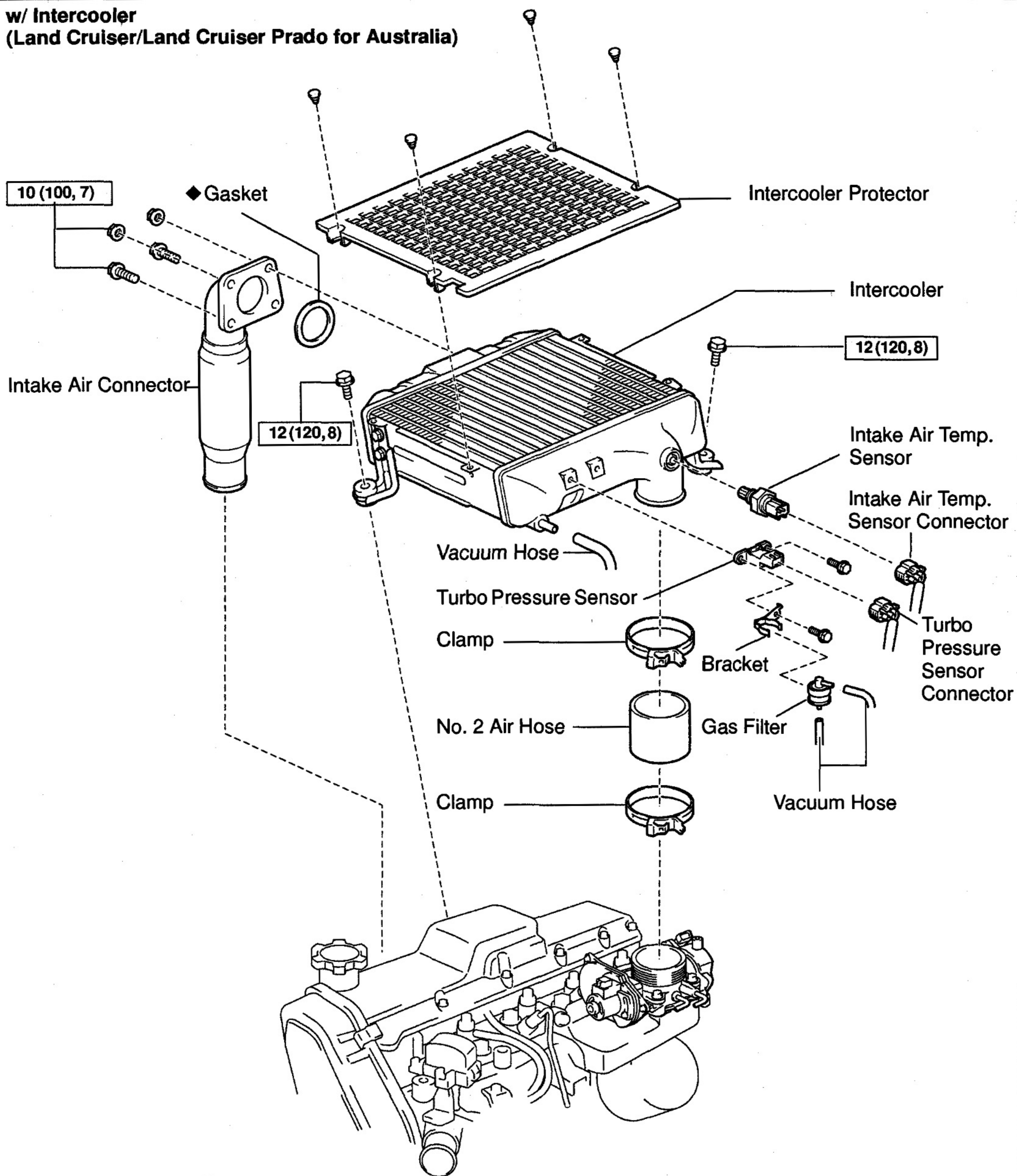

N·m (kgf·cm, ft·lbf) : Specified torque

◆ Non-reusable part

P

B13241

EMISSION CONTROL

PARTS LAYOUT AND SCHEMATIC DRAWING	EC-1
EXHAUST GAS RECIRCULATION (EGR) SYSTEM (w/ EGR)	EC-3

REFER TO 1KZ-TE ENGINE REPAIR MANUAL (Pub. No. RM710E)

NOTE: The above pages contain only the points which differ from the above listed manual.

EC

PARTS LAYOUT AND SCHEMATIC DRAWING

EC01Q-01

LOCATION

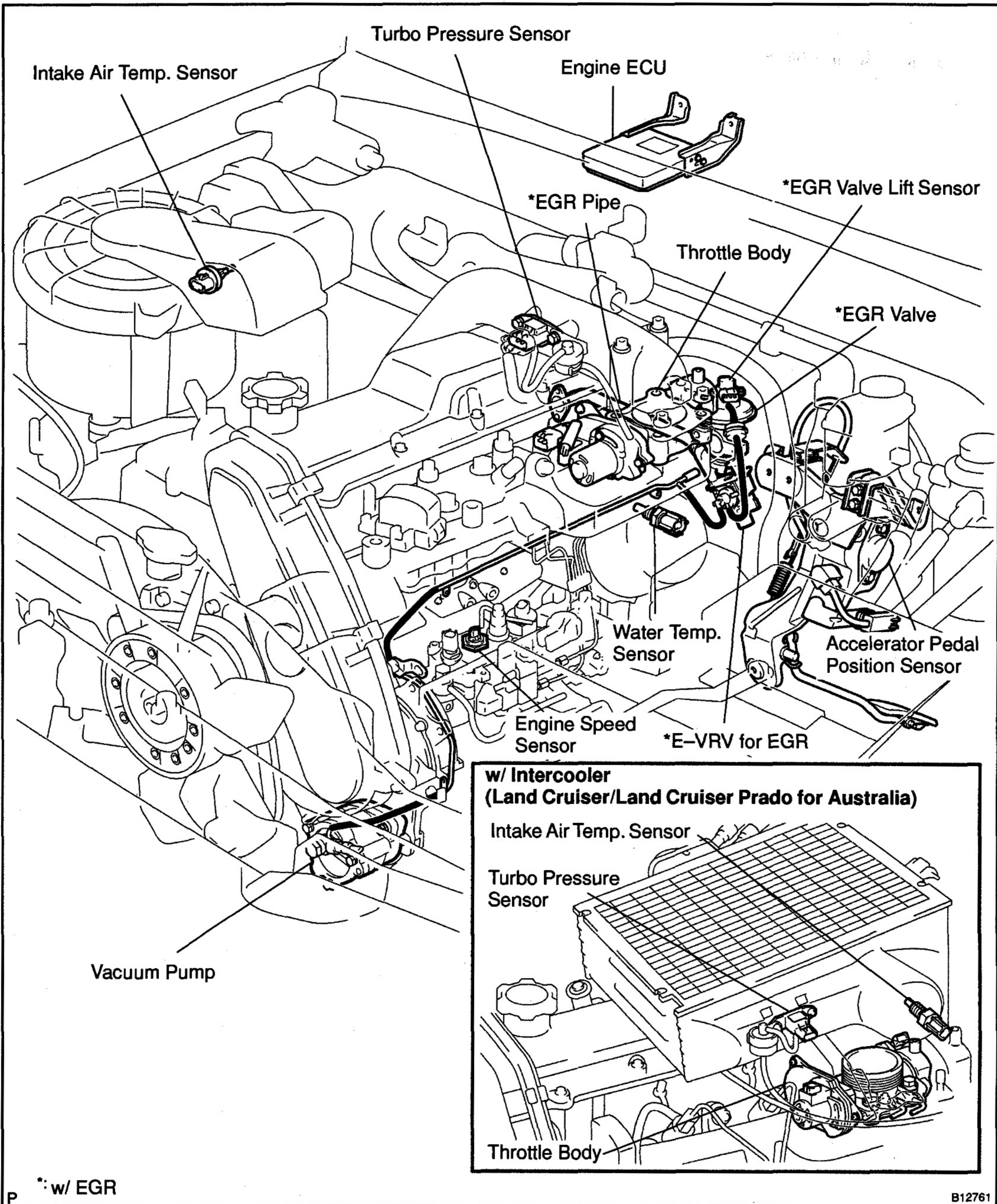

EC

DRAWING

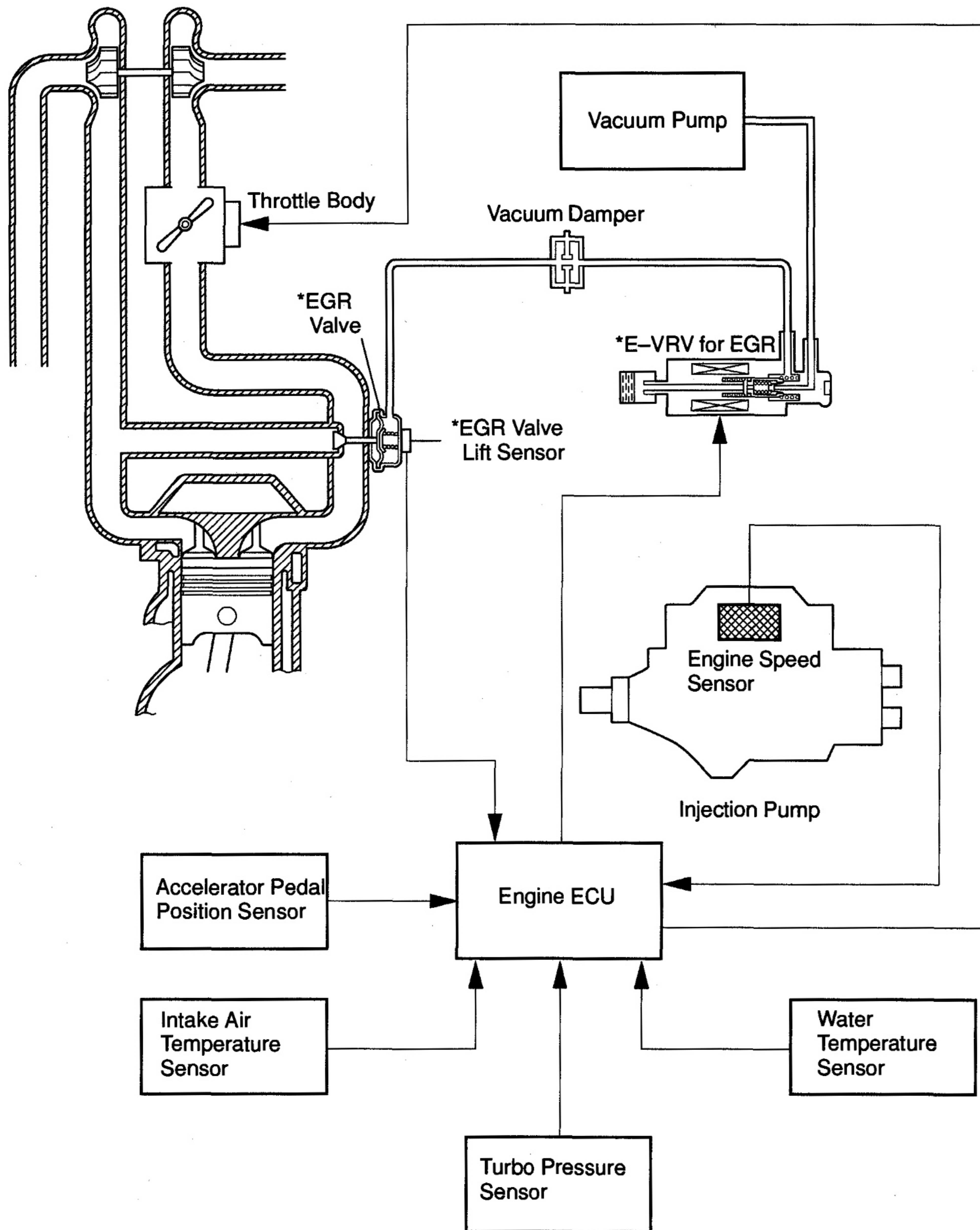

EC

*:w/ EGR

Y

B13116

EXHAUST GAS RECIRCULATION (EGR) SYSTEM (w/ EGR) ON-VEHICLE INSPECTION

EC01N-01

HINT:

In a malfunction where the EGR system is always on, black smoke or white smoke may be output from the exhaust pipe. If this occurs, inspect the EGR system also.

NOTICE:

Always stop the engine when installing or removing the vacuum gauges, or removing the vacuum hoses.

EC

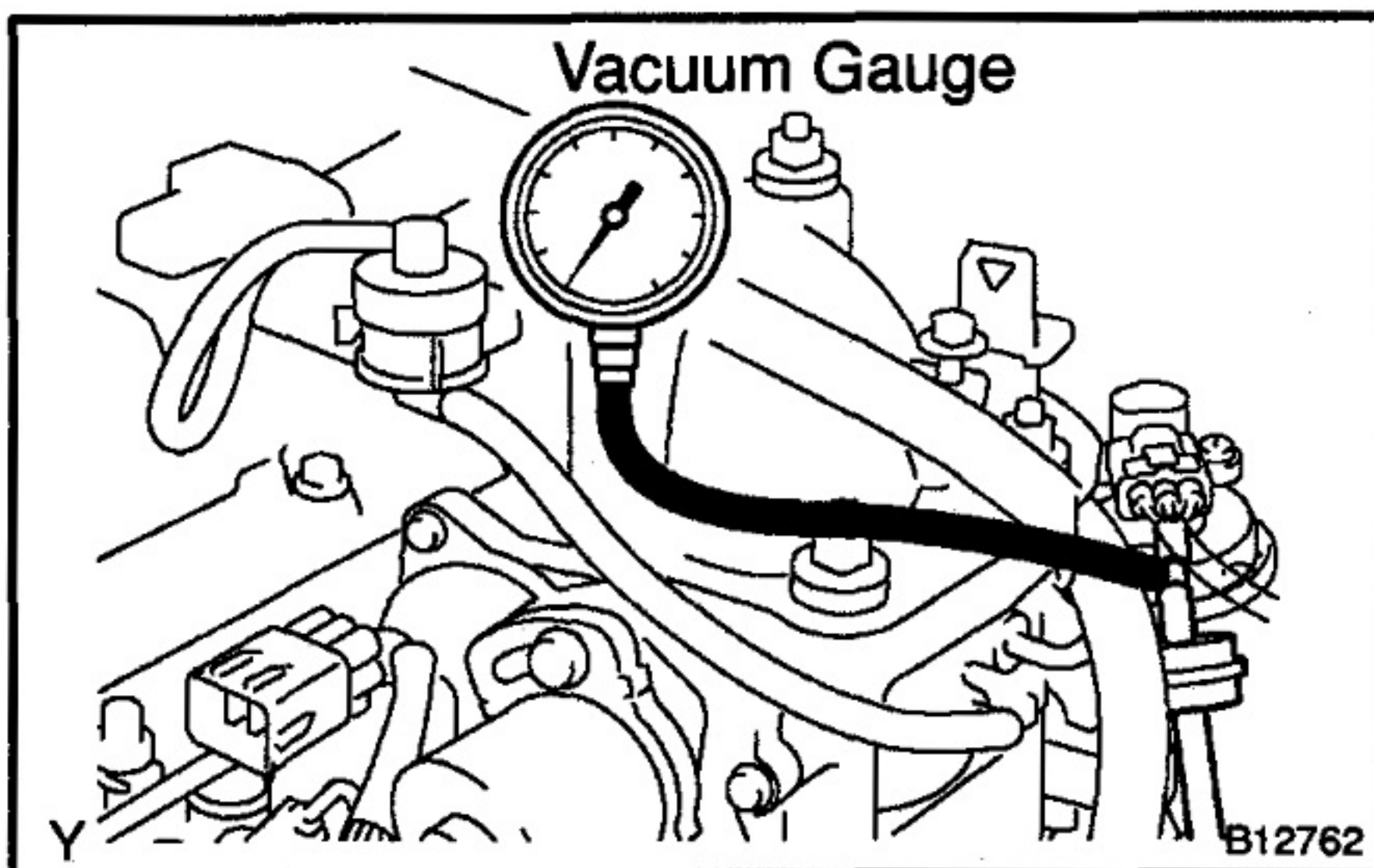
**1. INSTALL VACUUM GAUGE**

Using a 3 way connector, connect a vacuum gauge to the hose between the EGR valve and E-VRV.

2. INSPECT SEATING OF EGR VALVE

Start the engine and check that the engine starts and run at idle.

3. INSPECT COLD ENGINE CONDITION

- (a) The coolant temperature should be below 20°C (64°F).
- (b) Check that the vacuum gauge indicates 0 at idle.

4. INSPECT HOT ENGINE CONDITION

- (a) Warm up the engine, the coolant temperature should be above 70°C (104°F) and below 96°C (205°F).
- (b) Check that the vacuum gauge indicates about more than 28.0 kPa (210 mmHg, 8.3 in.Hg) at idle.
- (c) Check that the vacuum gauge indicator increases about more than 28.0 kPa (210 mm Hg, 8.3 in.Hg) at 1,500 rpm.
- (d) When the accelerator pedal is quickly depress to the full open, check that the vacuum gauge indicator drops momentarily.
- (e) Keep the engine speed at more than 4,000 rpm.
- (f) Check that the vacuum gauge indicates 0.
- (g) When the accelerator pedal is released, check that the vacuum gauge indicator drops momentarily while the engine speed decreases from more than 4,000 rpm to idle.

5. REMOVE VACUUM GAUGE

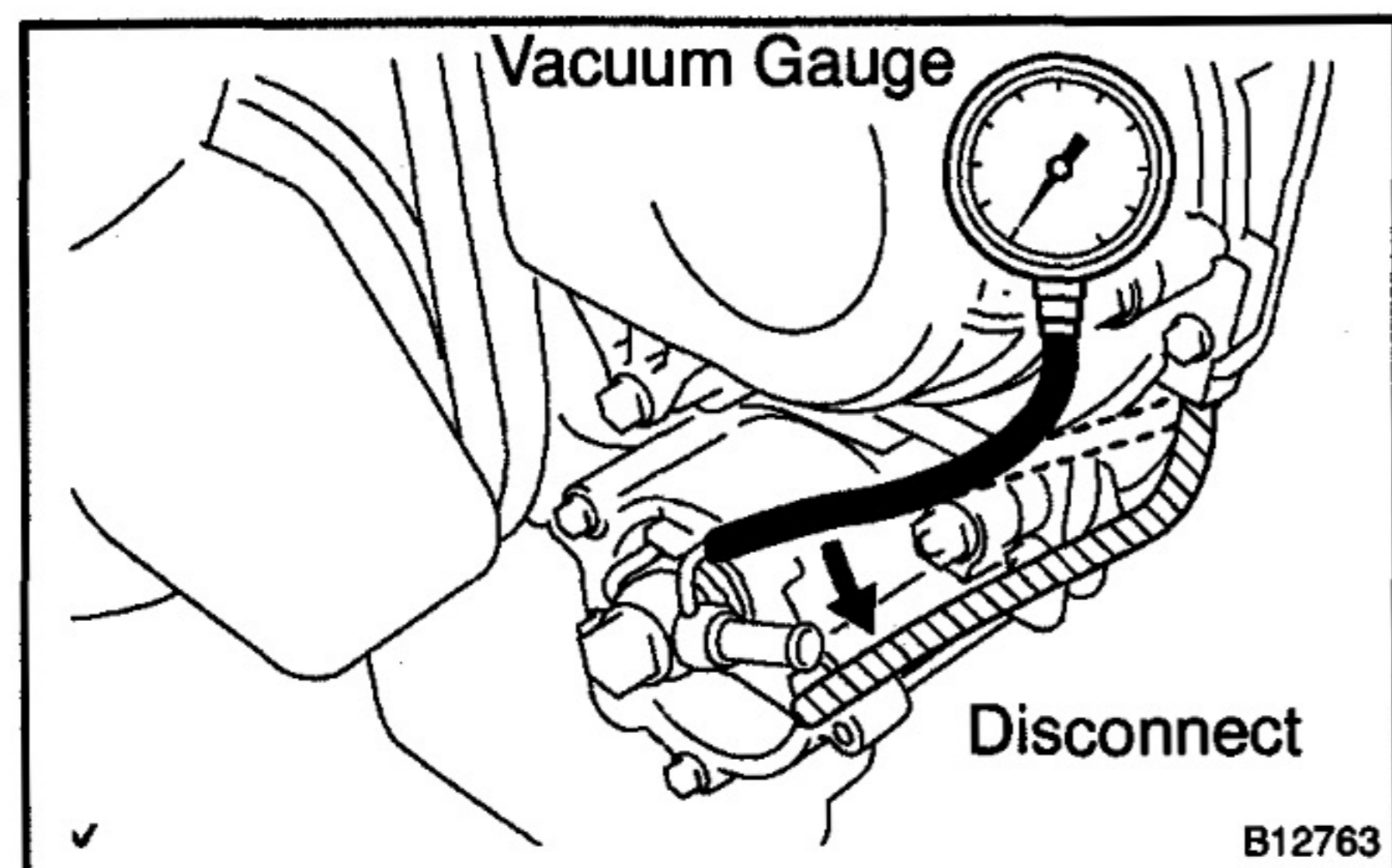
**6. CHECK OUTPUT VACUUM WITH VACUUM GAUGE**

- (a) Connect a vacuum gauge to the output pipe.
- (b) Warm up the engine and check that the vacuum gauge indicates above 86.7 kPa (650 mmHg, 25.59 in.Hg).

If a problem is found, repair the vacuum pump.

COMPONENTS

EC

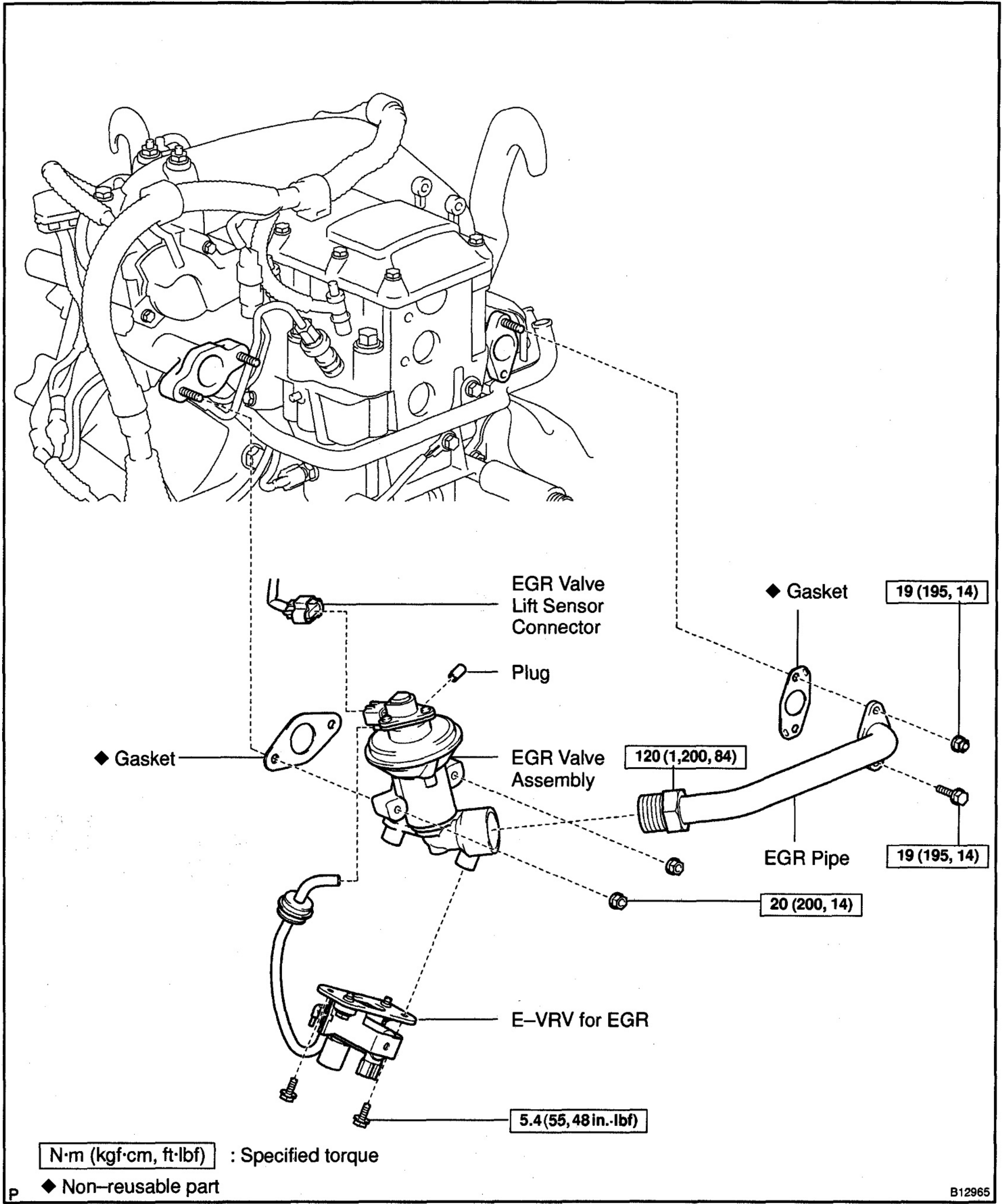

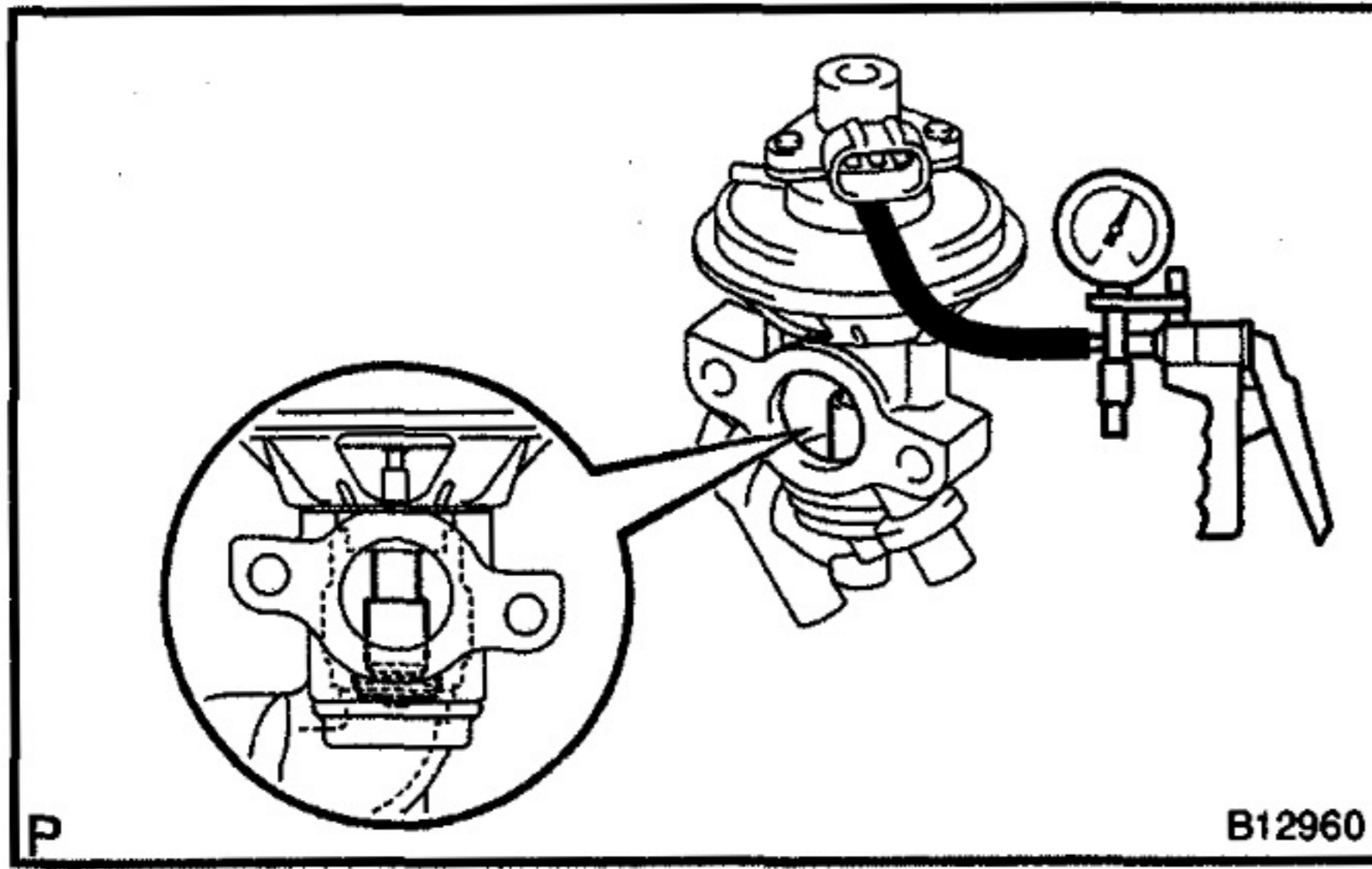

INSPECTION

1. INSPECT EGR VALVE

- (a) Remove the EGR valve.
- (b) Under the condition of applying the vacuum to the diaphragm chamber, check the valve operation.

Vacuum	EGR Valve
Less than 13 kPa (100 mmHg, 3.8 in. Hg)	Closed
More than 27 kPa (200 mmHg, 8.0 in. Hg)	Open

- (c) When applying more than 67 kPa (500 mmHg, 19 in.Hg) of the vacuum, check if there is any leakage of the vacuum.
- (d) Check the valve for sticking and heavy carbon deposits. If a problem is found, replace it.

EC

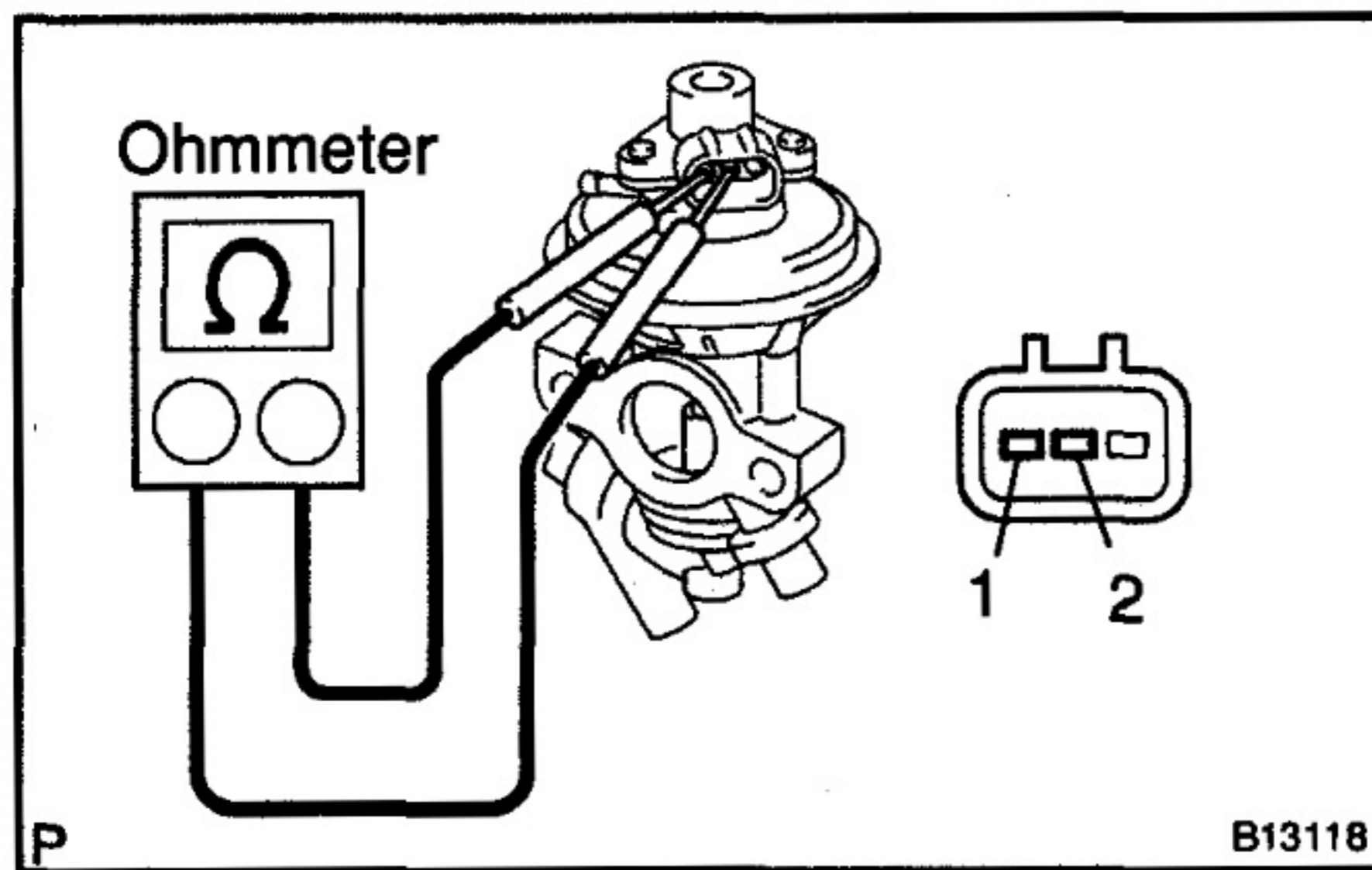

- (e) Using an ohmmeter, check the resistance between terminals 1 and 2 of the EGR lift sensor.
Resistance: 2.6 kΩ at 20°C (68°F)

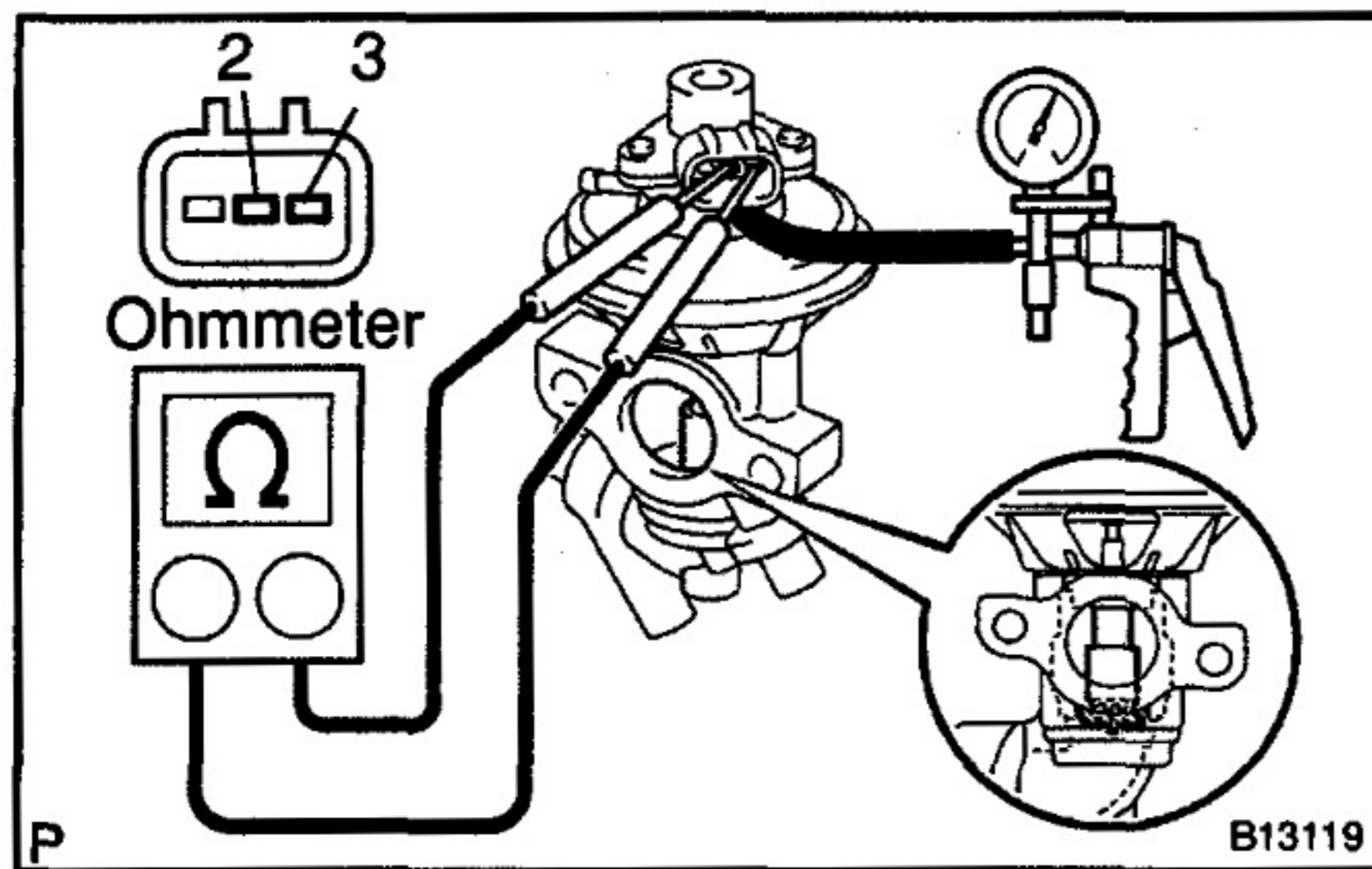

- (f) Apply vacuum to the diaphragm chamber and then check each resistance between terminals of 3 and 2 of the lift sensor when the valve is fully opened and also when fully closed.

Resistance:

EGR Valve	Resistance
Fully opened	0.6 kΩ at 20°C (68°F)
Fully closed	2.2 kΩ at 20°C (68°F)

HINT:

The resistance valve increases in proportion to the opening angle of the EGR valve.

- (g) Reinstall the EGR valve.
- 2. **INSPECT E-VRV FOR EGR (See page ED-11)**
- 3. **INSPECT ACCELERATOR PEDAL POSITION SENSOR (See page ED-19)**
- 4. **INSPECT ENGINE SPEED SENSOR (See page ED-17)**
- 5. **INSPECT INTAKE AIR TEMPERATURE SENSOR (See page ED-13)**

6. **INSPECT WATER TEMPERATURE SENSOR**
(See Pub. No. RM710E, page ED-15)
7. **INSPECT TURBO PRESSURE SENSOR** (See page
ED-15)

ELECTRONIC CONTROL DIESEL

THROTTLE BODY	ED-1
TIMING CONTROL VALVE	ED-8
SPILL CONTROL VALVE	ED-9
E-VRV FOR EGR (w/ EGR)	ED-10
FUEL TEMPERATURE SENSOR	ED-12
INTAKE AIR TEMPERATURE SENSOR	ED-13
TURBO PRESSURE SENSOR	ED-14
ENGINE SPEED SENSOR	ED-17
ACCELERATOR PEDAL	
POSITION SENSOR	ED-18
ACCELERATOR PEDAL	
CLOSED POSITION SWITCH	ED-20
FIRST GEAR POSITION SWITCH (M/T)	ED-21
INJECTION PUMP CORRECTION UNIT	ED-23

ED

REFER TO FOLLOWING REPAIR MANUALS:

Manual Name	Pub. No.
1KZ-T Engine Repair Manual	RM353E
1KZ-TE Engine Repair Manual	RM710E
1KZ-T, 1KZ-TE Engine Repair Manual Supplement	RM522E

NOTE: The above pages contain only the points which differ from the above listed manuals.

THROTTLE BODY ON-VEHICLE INSPECTION

ED02R-02

1. INSPECT THROTTLE FULL SWITCH

- (a) w/ Intercooler:
Remove the intercooler assembly (See page EM-2).
- (b) w/o Intercooler:
Remove the intake pipe (See page EM-2).
- (c) Disconnect the switch connector.
- (d) Using an ohmmeter, check the continuity between the terminals.

Continuity:

Throttle Valve	Continuity
Fully closed	No continuity
Fully open	Continuity

If the continuity is not as specified, replace the throttle body (See page ED-4).

- (e) Reconnect the switch connector.
- (f) w/ Intercooler:
Reinstall the inter cooler assembly (See page EM-2).
- (g) w/o Intercooler:
Reinstall the intake pipe (See page EM-2).

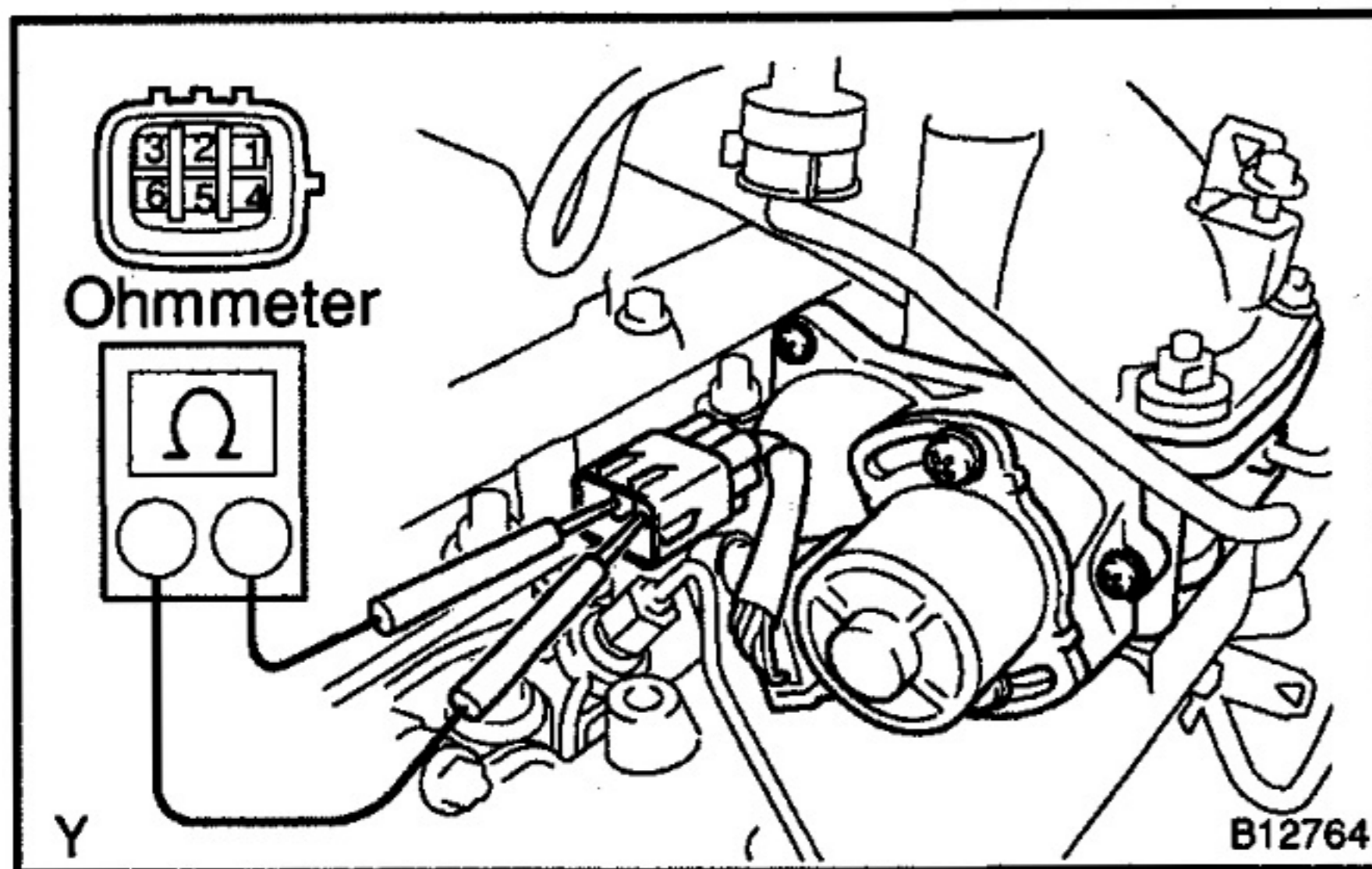
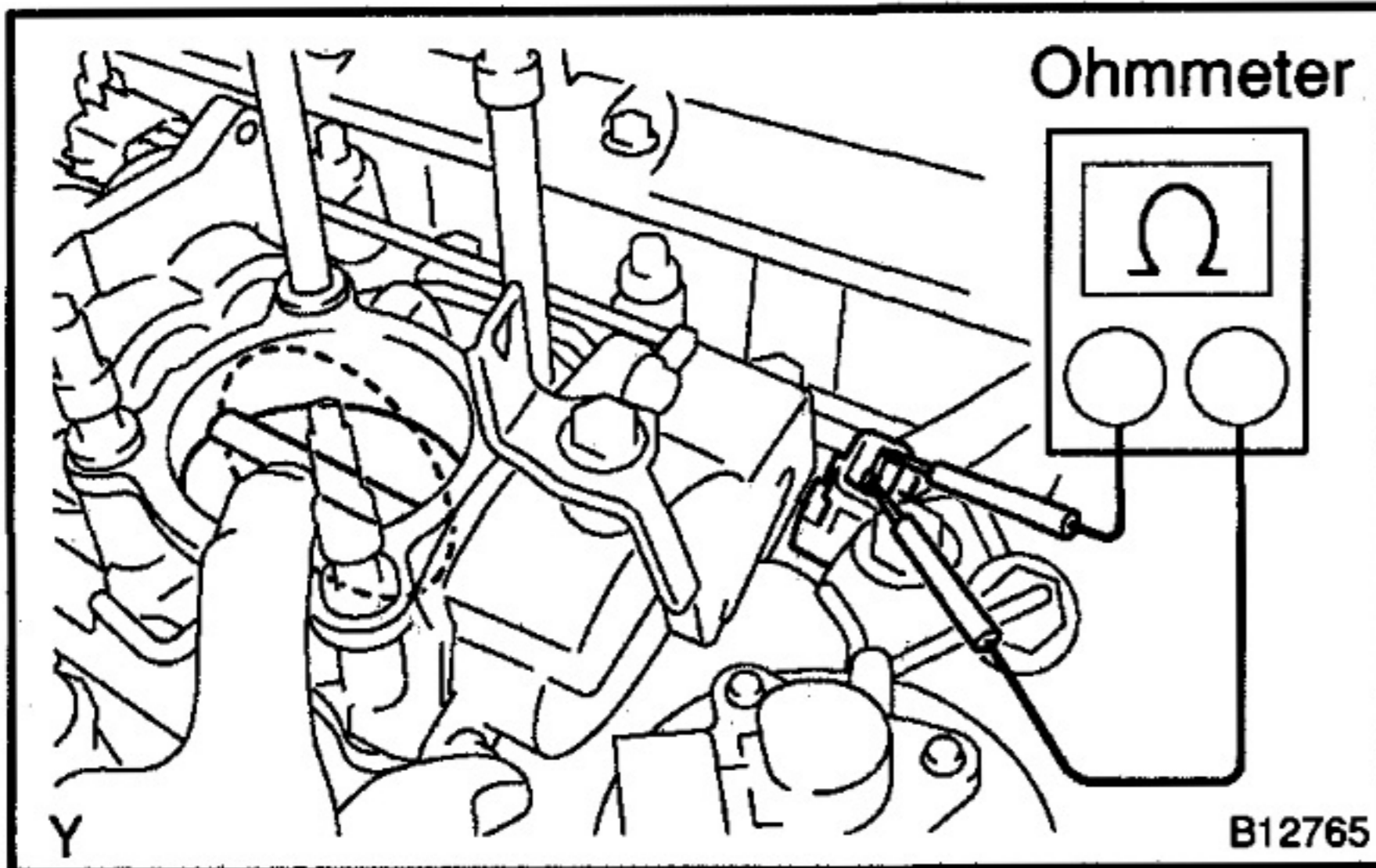

2. INSPECT THROTTLE CONTROL MOTOR

NOTICE:

"Cold" and "Hot" in the following sentences express the temperature of the coils themselves. "Cold" is from -10°C (14°F) to 50°C (122°F) and "Hot" is from 50°C (122°F) to 100°C (212°F).

- (a) Disconnect the motor connector.
- (b) Using an ohmmeter, measure the resistance between terminals 2 and 1/3, and 5 and 4/6.

Resistance:

Cold	23 - 33 Ω
Hot	29 - 39 Ω

If the resistance is not as specified, replace the throttle body (See page ED-4).

- (c) Reconnect the motor connector.
- (d) w/ Intercooler:
Reinstall the inter cooler assembly (See page EM-2).
- (e) w/o Intercooler:
Reinstall the intake pipe (See page EM-2).

COMPONENTS

w/ Intercooler (Land Cruiser/Land Cruiser Prado for Australia)

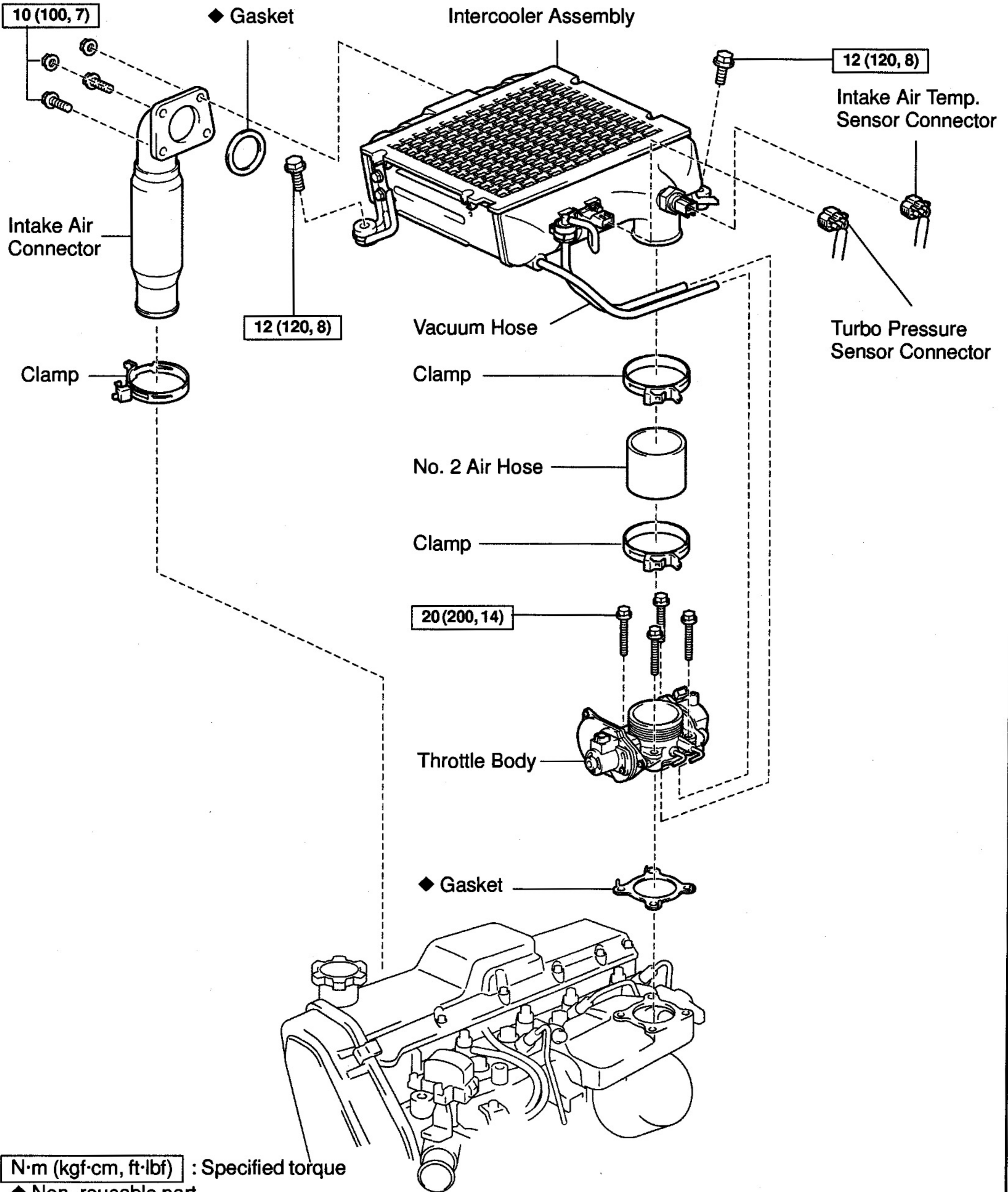

ED

P

w/o Intercooler

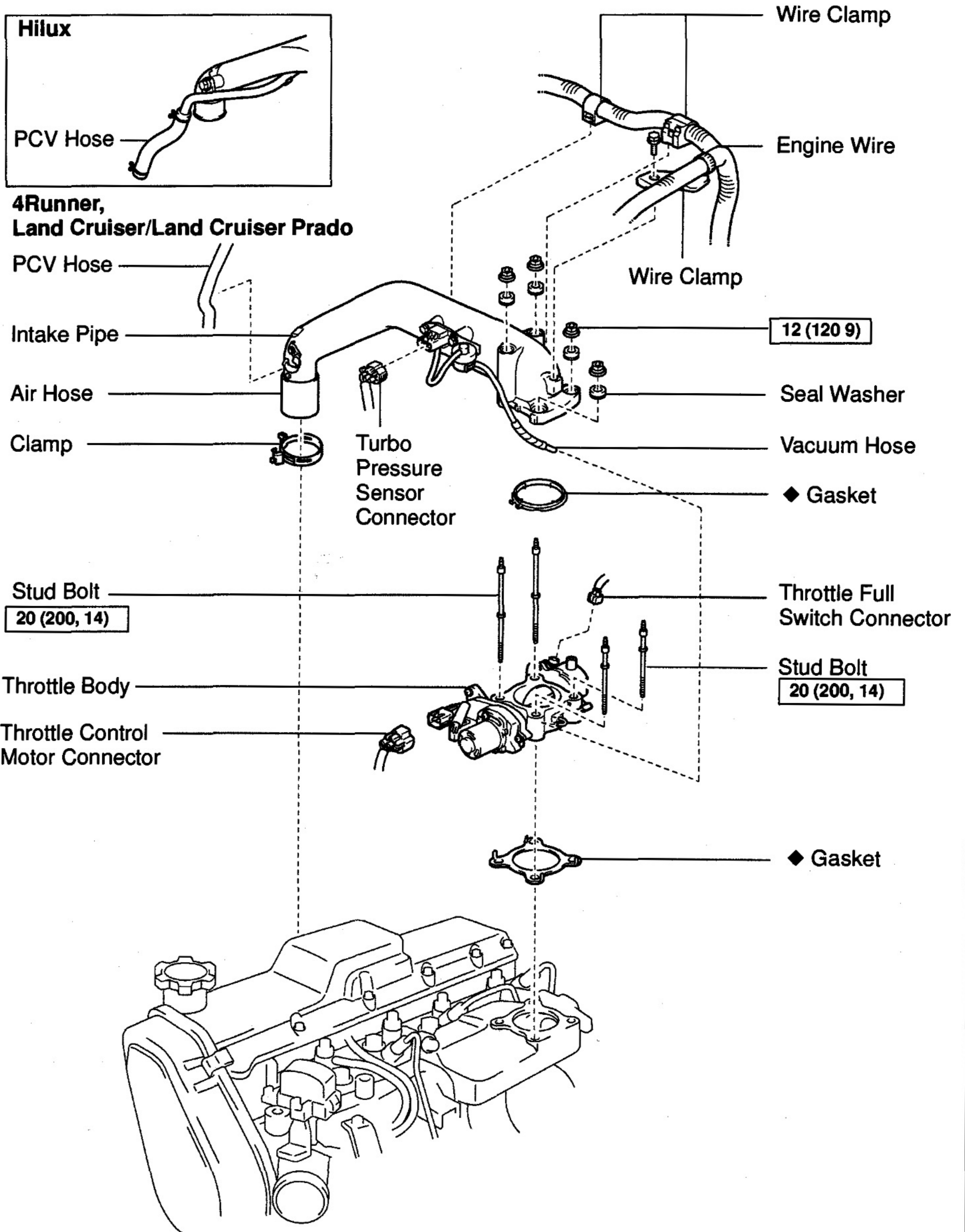

ED

N·m (kgf·cm, ft·lbf) : Specified torque

◆ Non-reusable part

P

REMOVAL

1. w/ Intercooler:

REMOVE INTERCOOLER ASSEMBLY

- (a) Disconnect the turbo pressure sensor connector.
- (b) Disconnect the intake air temperature sensor connector.
- (c) Disconnect the 2 vacuum hoses from the throttle body.
- (d) Use pliers to pinch the ends of the clamp together until the lock plate engages the catch.
Make sure the lock plate and catch are engaged securely.
- (e) Remove the 2 nuts, 2 bolts, intake air connector and gasket.
- (f) Remove the 2 bolts and the intercooler assembly.
- (g) Remove the 2 clamps and No. 2 air hose with the 2 clamps.

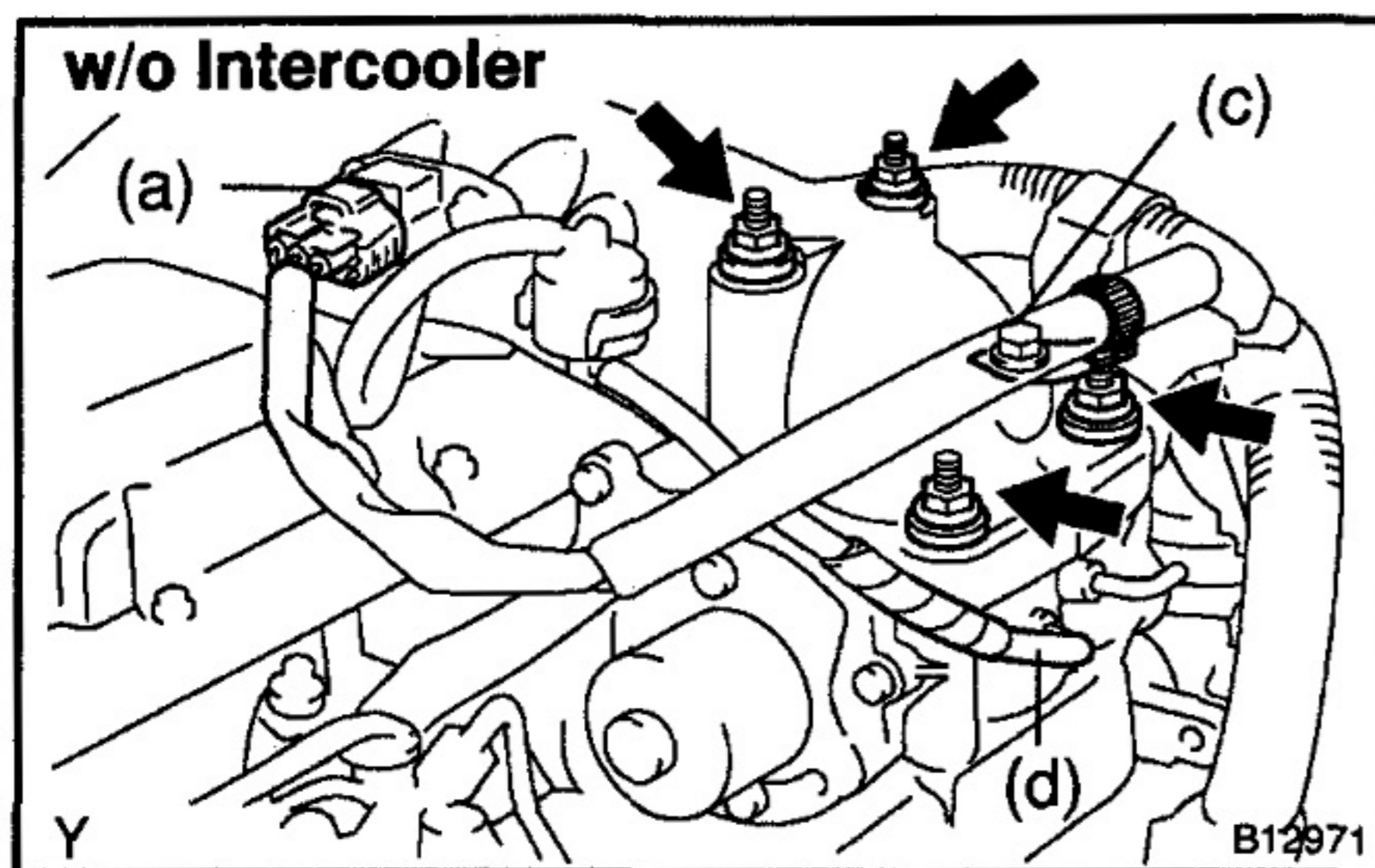

2. w/o Intercooler:

REMOVE INTAKE PIPE

- (a) Disconnect the turbo pressure sensor connector.
- (b) Disconnect the 2 wire clamps.
- (c) Remove the bolt and disconnect the wire.
- (d) Disconnect the vacuum hose from the throttle body.
- (e) Remove the 4 nuts and 4 seal washers.
- (f) Hilux:
Disconnect the 2 PCV hoses.
- (g) 4Runner, Land Cruiser/Land Cruiser Prado:
Disconnect the PCV hose from the clamp.
- (h) Use pliers to pinch the ends of the clamp together until the lock plate engages the catch.
Make sure the lock plate and catch are engaged securely.
- (i) Remove the intake pipe and gasket.

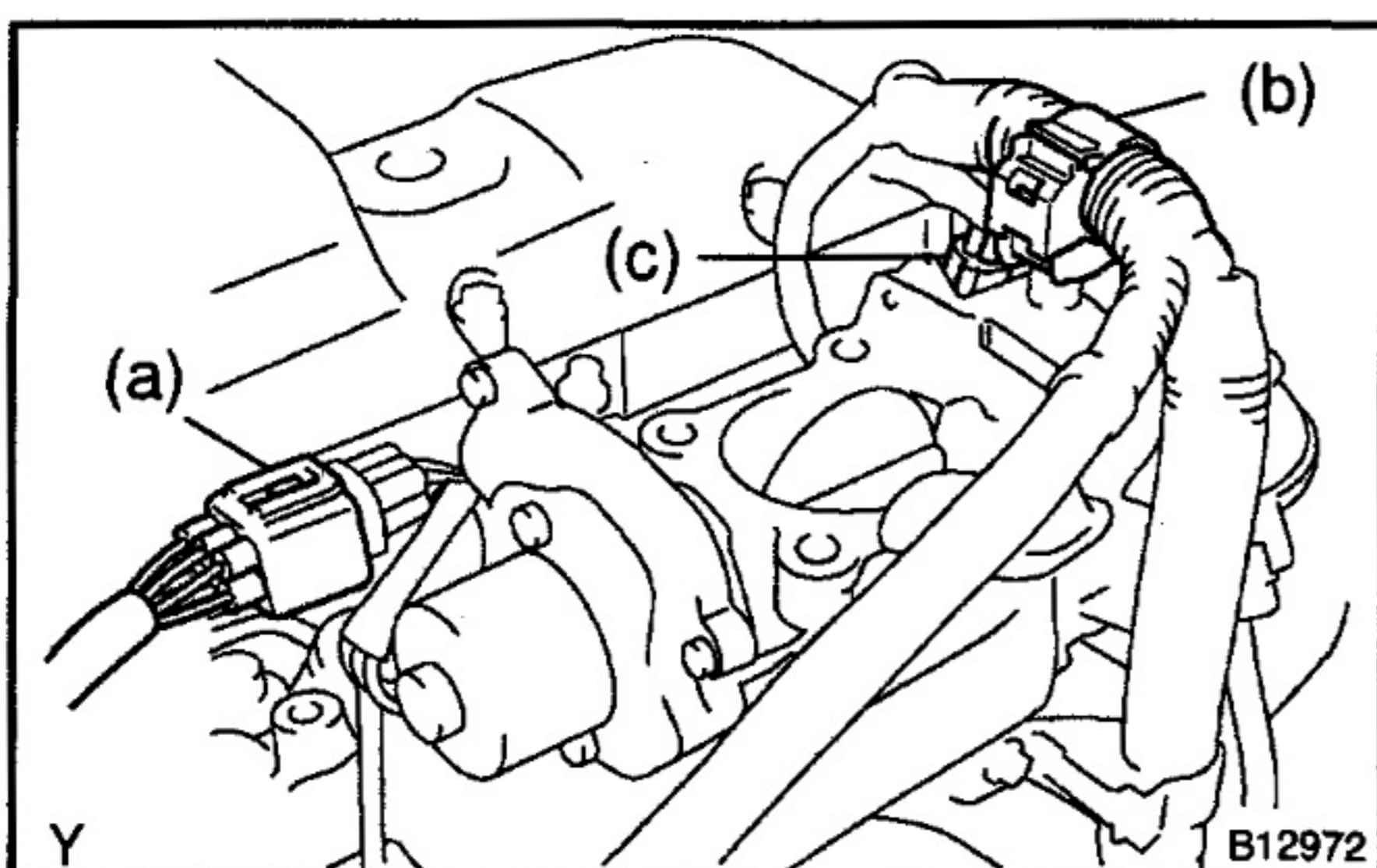
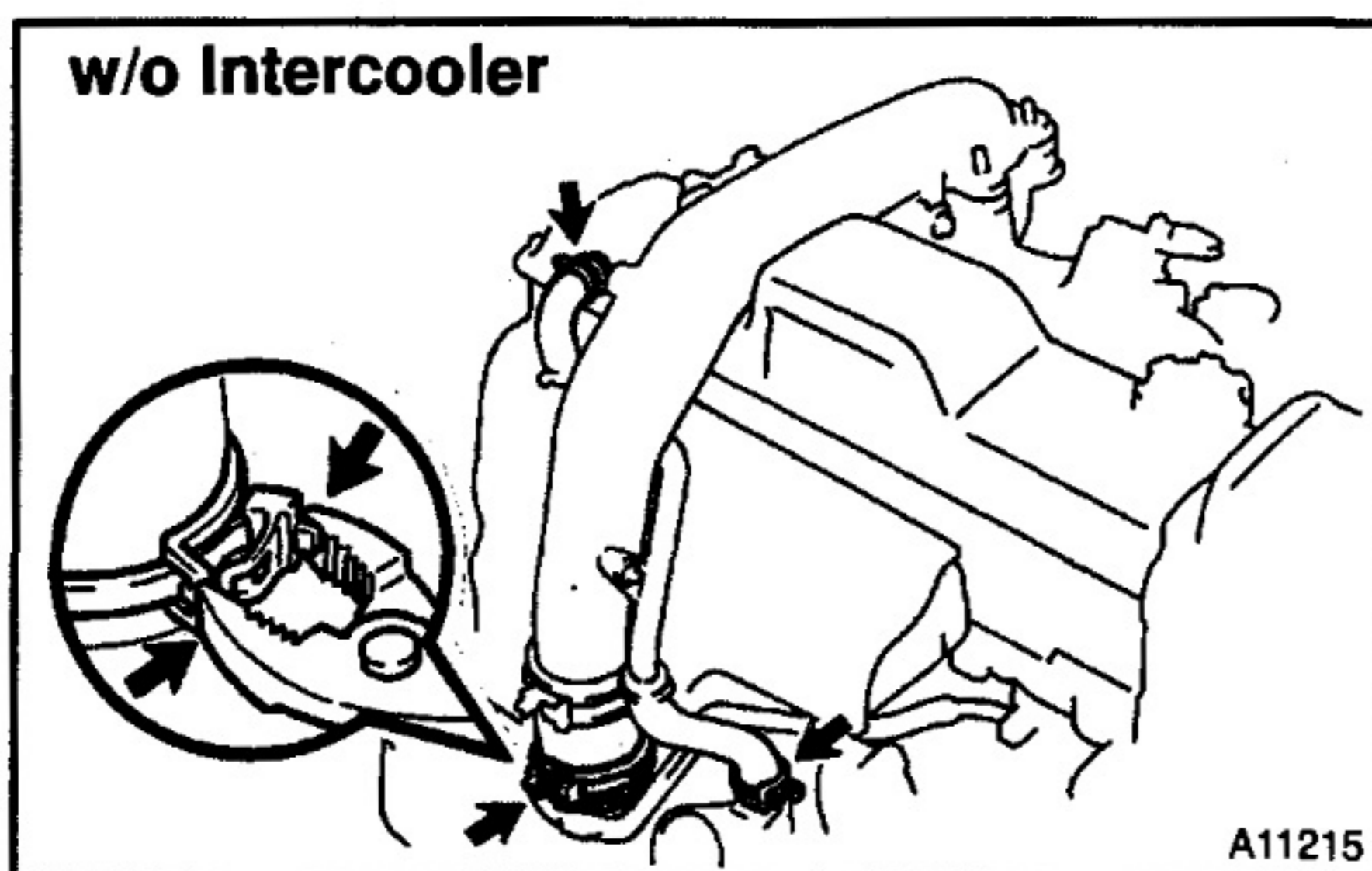

3. REMOVE THROTTLE BODY

- (a) Disconnect the throttle control motor connector.
- (b) Disconnect the wire clamp from the bracket.
- (c) Disconnect the throttle full switch connector.
- (d) w/ Intercooler:
Remove the 4 bolts.

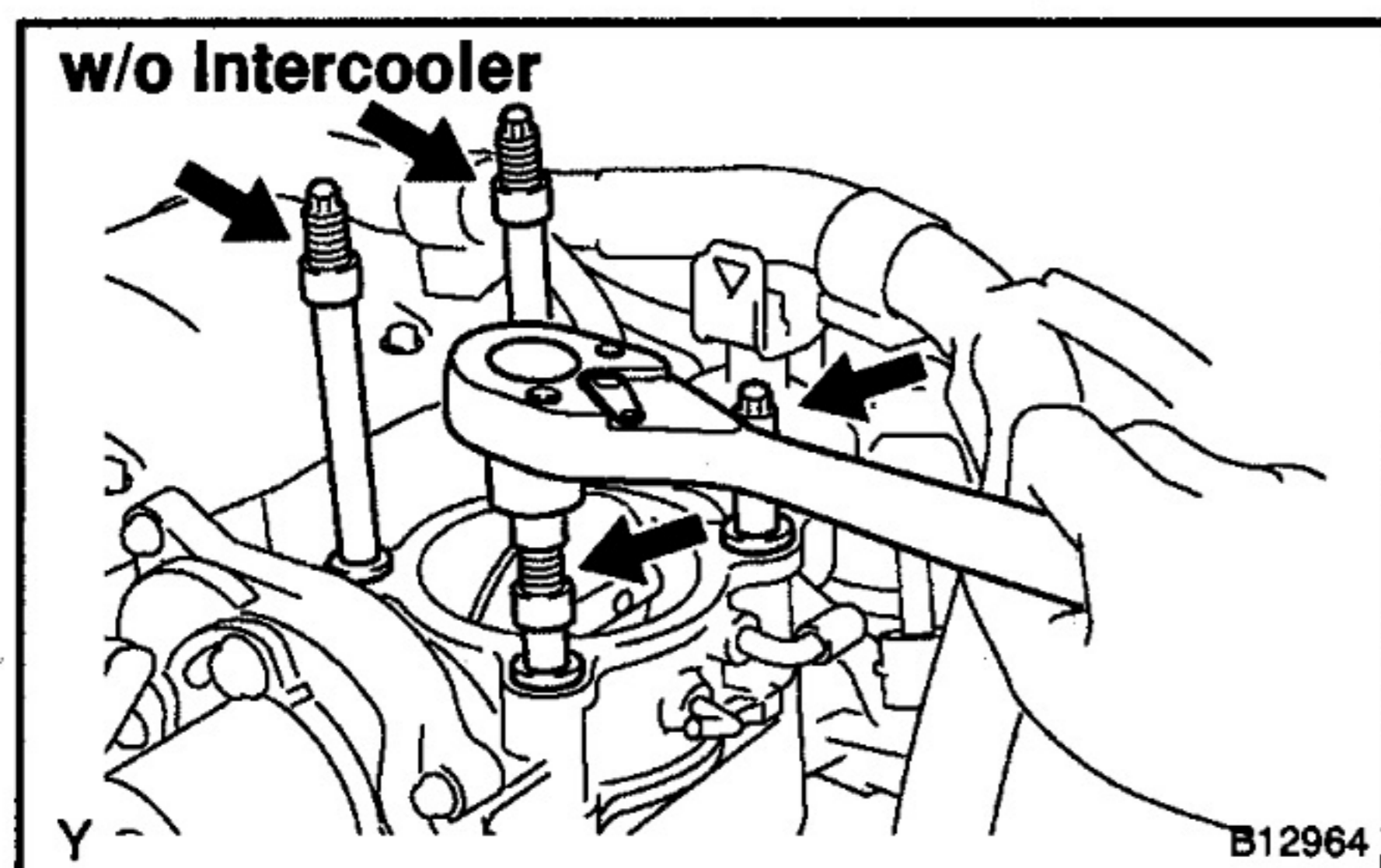

(e) w/o Intercooler:
Using a torx socket wrench (E8), remove the 4 stud bolts for the throttle body.

(f) Remove the throttle body and gasket.

NOTICE:

Do not disassemble the throttle body.

INSTALLATION

1. INSTALL THROTTLE BODY

- (a) **w/ Intercooler:**
Install a new gasket and the throttle body with the 4 bolts.
Torque: 20 N·m (200 kgf·cm, 15 ft·lbf)
- (b) **w/o Intercooler:**
Install a new gasket and the throttle body.

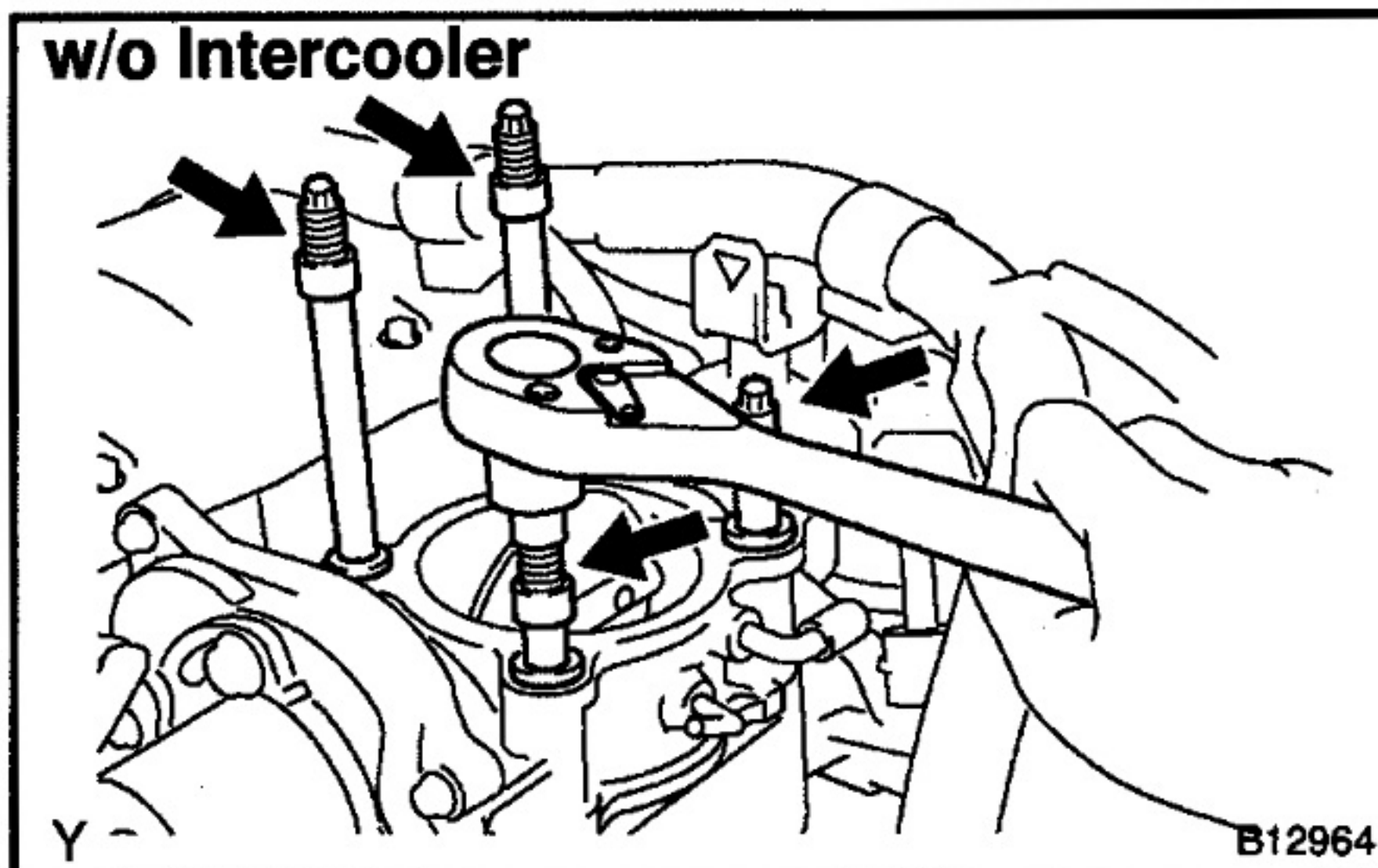

- (c) **w/o Intercooler:**
Using a torx socket wrench (E8), install the 4 stud bolts for the throttle body.
Torque: 20 N·m (200 kgf·cm, 14 ft·lbf)

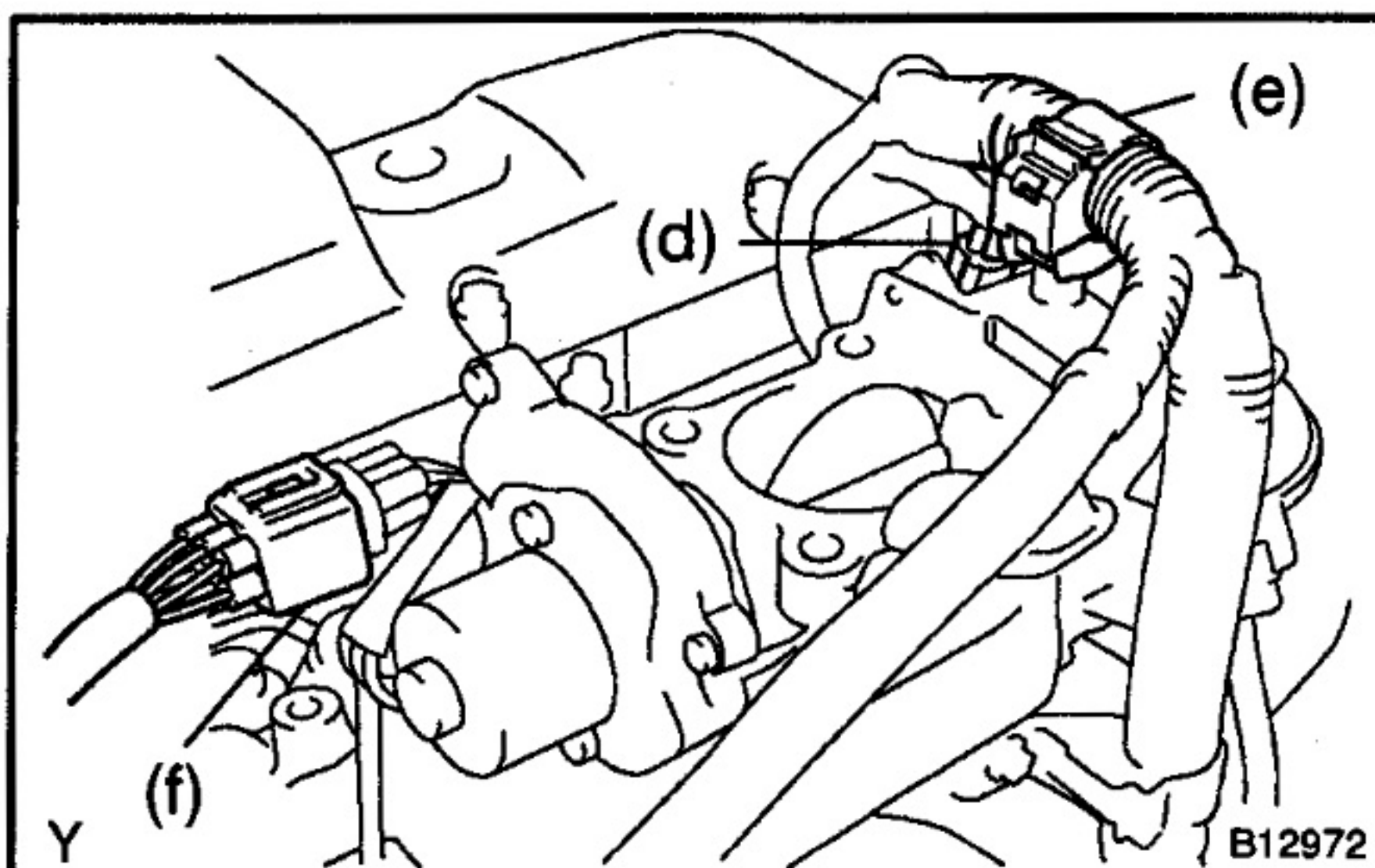

- (d) Connect the throttle full switch connector.
(e) Connect the wire clamp to the bracket.
(f) Connect the throttle control motor connector.

2. w/ Intercooler:

INSTALL INTERCOOLER ASSEMBLY

- (a) Install the No. 2 air hose and intake air connector, and place the clamp lock together with the pliers and press down the tip of the lock plate. Carefully let the lock spread apart. Take care not to let the pliers slip.
- (b) Install the intercooler with the 2 bolts.
Torque: 12 N·m (200 kgf·cm, 14 ft·lbf)
- (c) Install a new gasket and the intake air connector with the 2 bolts and 2 nuts.
Torque: 10 N·m (100 kgf·cm, 7 ft·lbf)
- (d) Connect the 2 vacuum hoses to the throttle body.
(e) Connect the intake air temperature sensor connector.
(f) Connect the turbo pressure sensor connector.

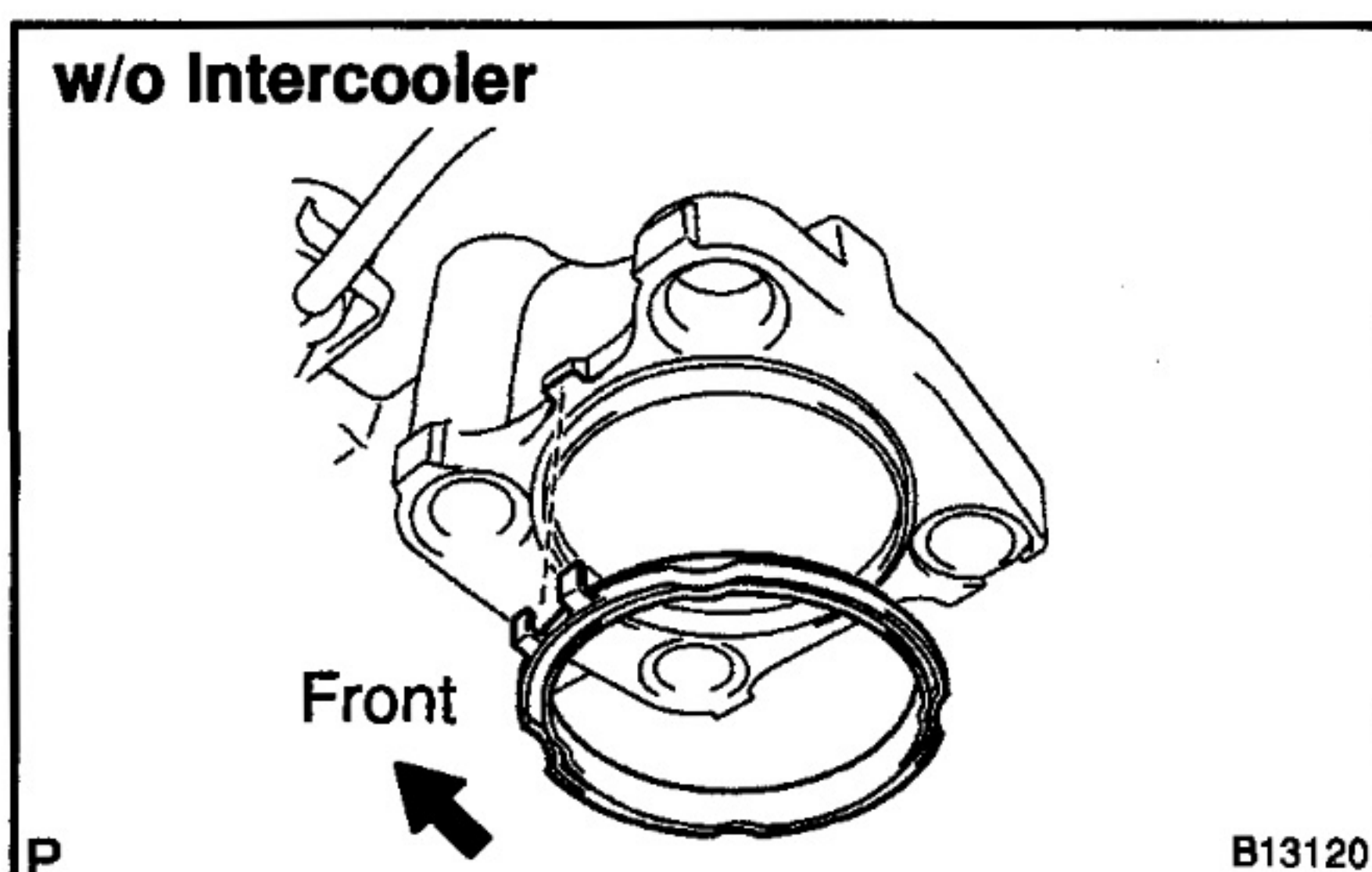

3. w/o Intercooler:

INSTALL INTAKE PIPE

- (a) Install a new gasket to the intake pipe as shown in the illustration.

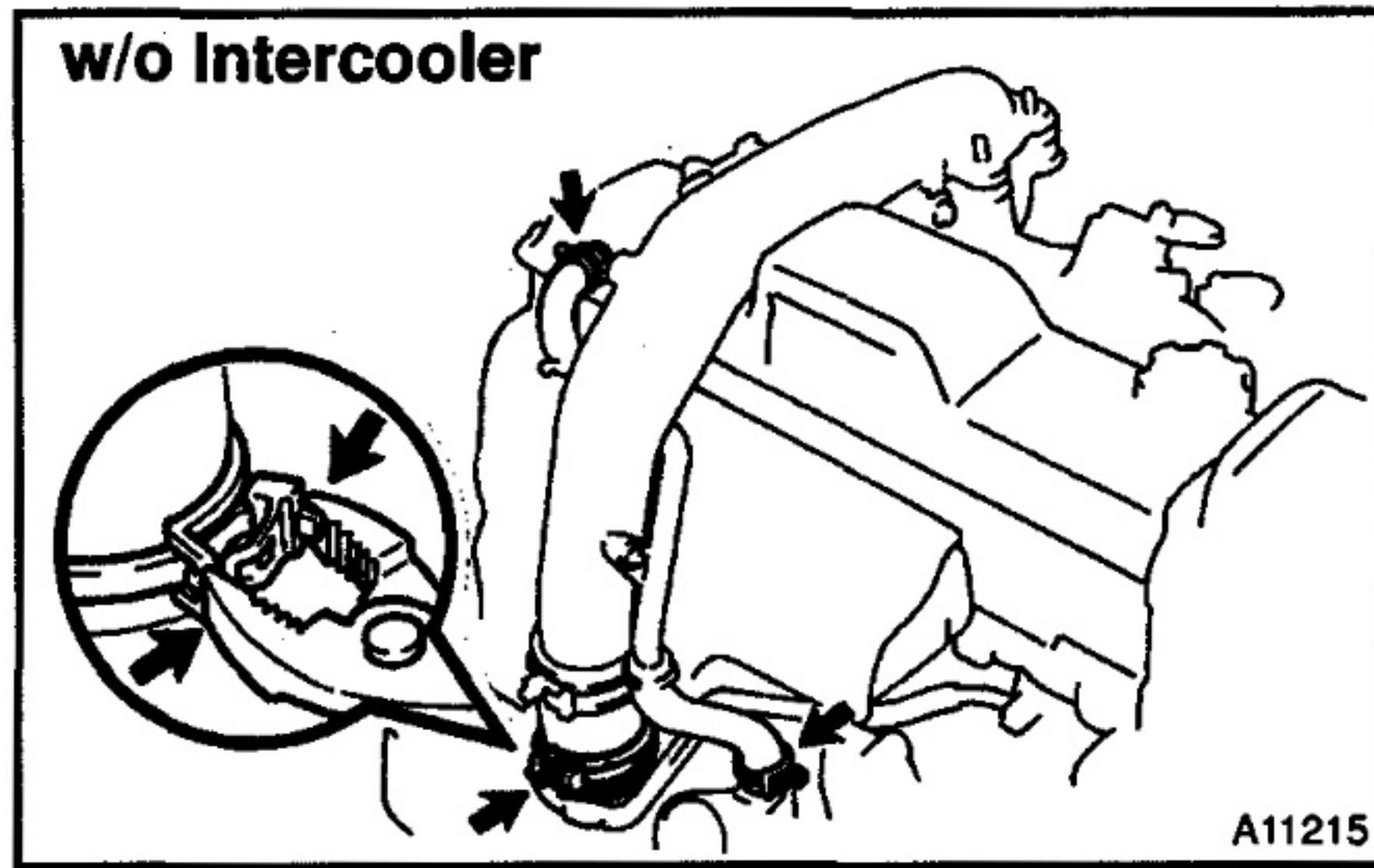

(b) Connect the air hose to the turbocharger, and place the clamp lock together with the pliers and press down the tip of the lock plate. Carefully let the lock spread apart. Take care not to let the pliers slip.

(c) Hilux:
Connect the 2 PCV hoses.

(d) 4runner, Land Cruiser/Land Cruiser Prado:
Connect the PCV hose to the clamp.

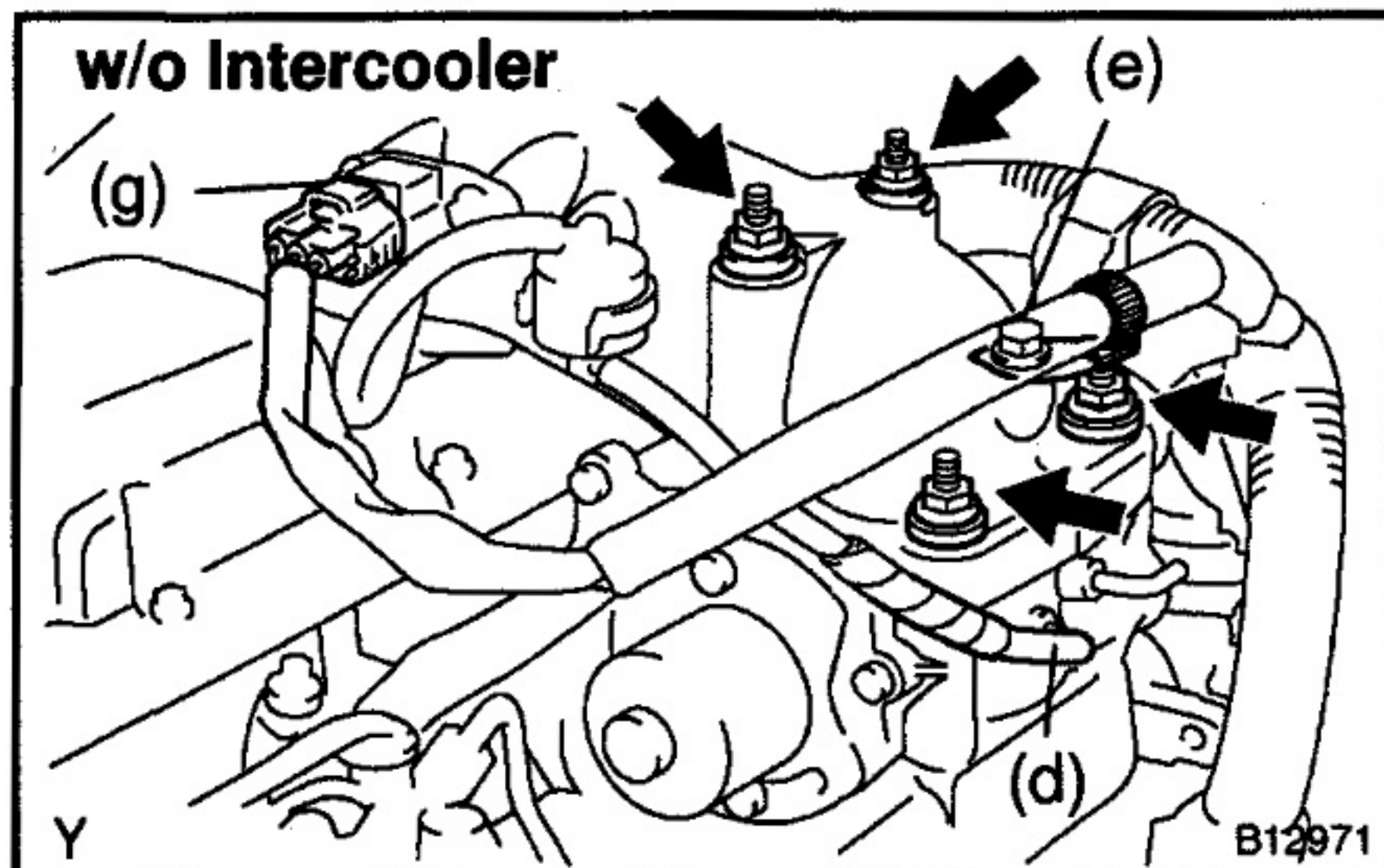

(e) Install the intake pipe to the throttle body with the 4 seal washers and 4 nuts.

Torque: 12 N·m (120 kgf·cm, 8 ft·lbf)

(f) Connect the vacuum hose to the throttle body.

(g) Install the wire with the bolt.

(h) Install the 2 wire clamps.

(i) Connect the turbo pressure sensor connector.

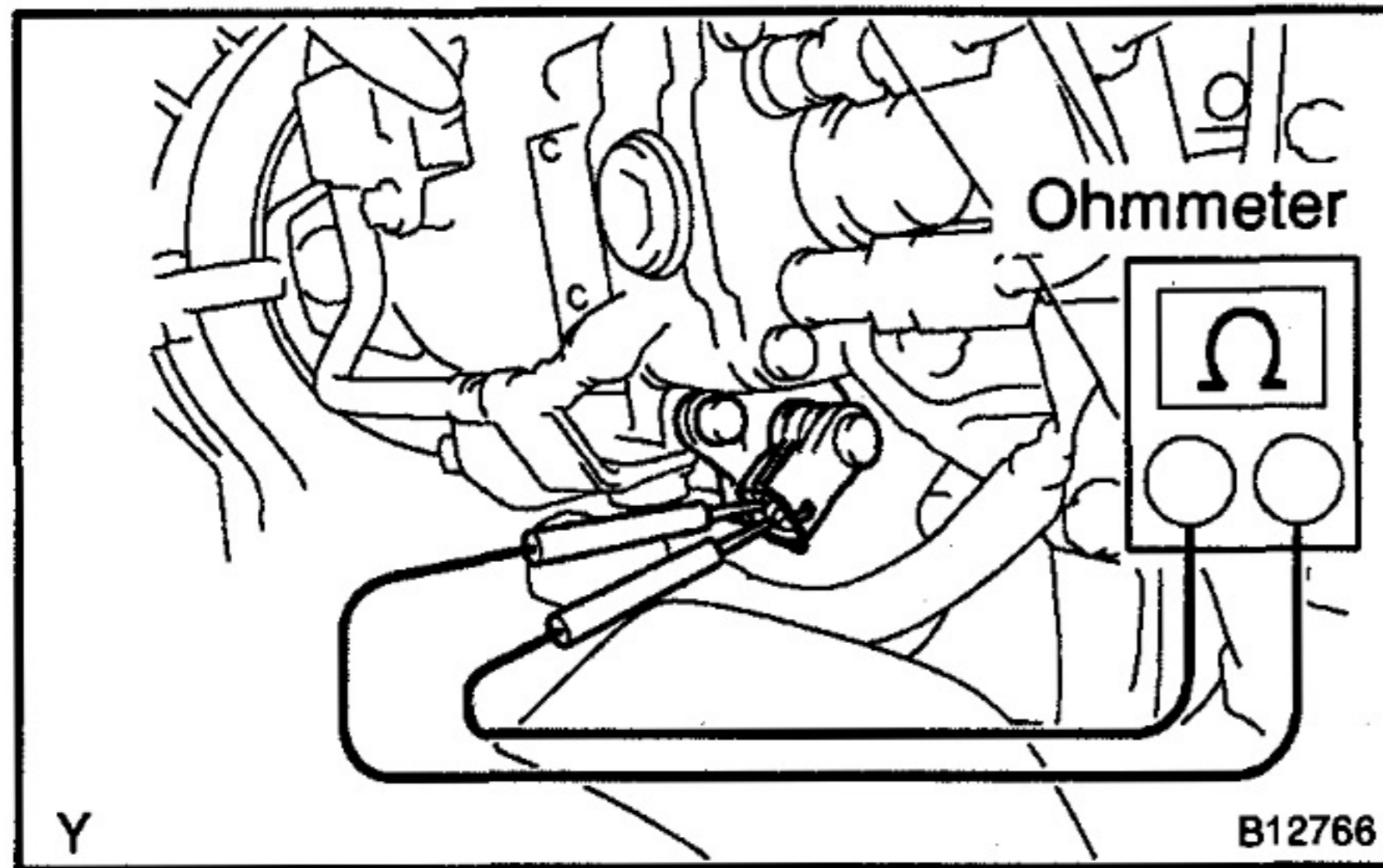

TIMING CONTROL VALVE INSPECTION

ED03V-01

INSPECT TIMING CONTROL VALVE

- (a) Disconnect the valve connector.
- (b) Using an ohmmeter, measure the resistance between the terminals.

Resistance: 10 – 14 Ω at 20°C (68°F)

If the resistance is not specified, replace the valve.

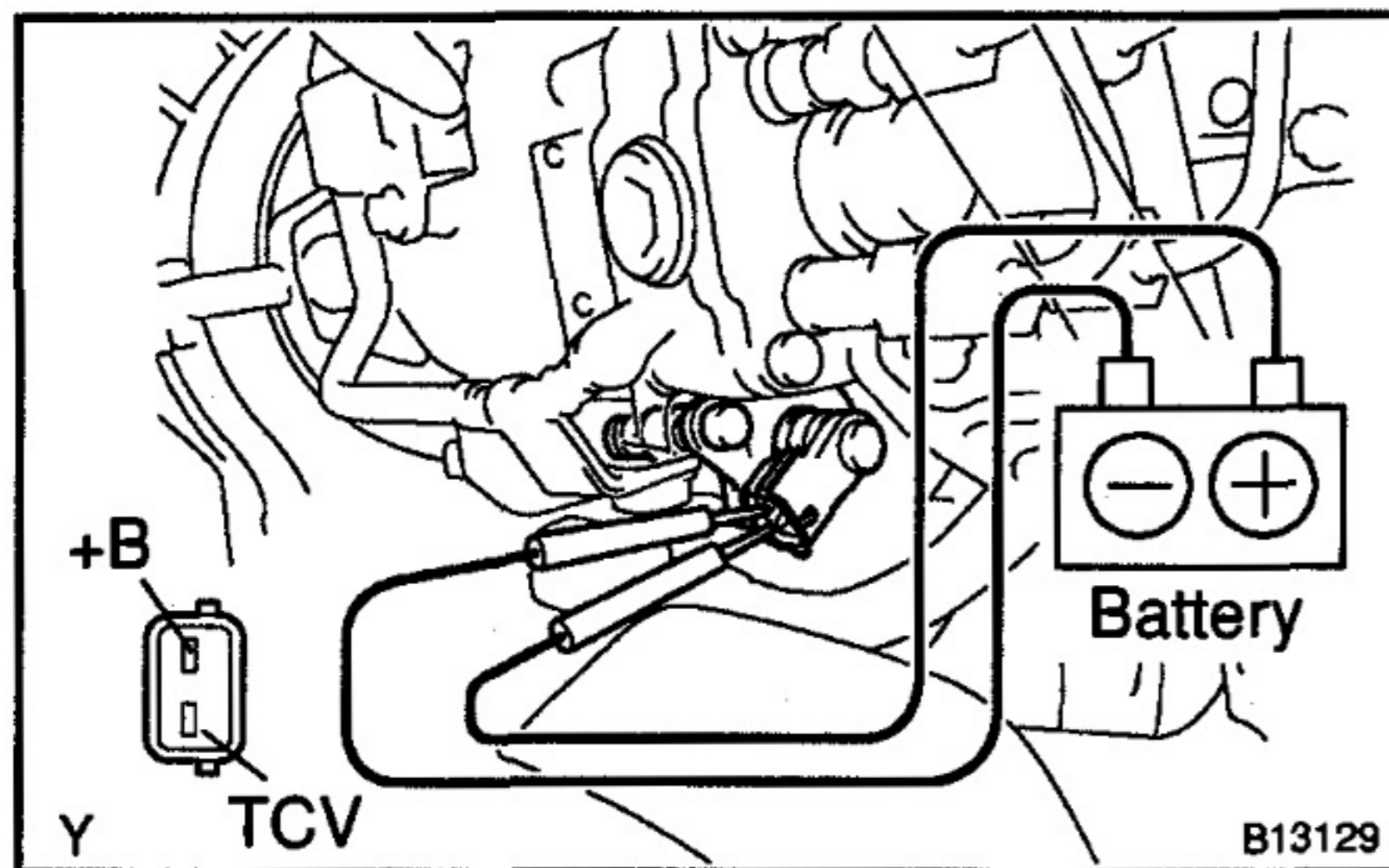

- (c) Inspect the valve solenoid operation.
 - (1) Connect the battery positive (+) terminal to the valve terminal +B.
 - (2) Connect the battery negative (-) terminal to the valve terminal TCV.
 - (3) Check that the solenoid makes a "clicks" sound.

If operation is not as specified, replace the valve.

NOTICE:

- Do not apply voltage for more than 30 seconds to avoid burning out the solenoid.
 - If repeating this step, wait until the solenoid coils become cool enough that it can be touched by hand.
- (d) Reconnect the valve connector.

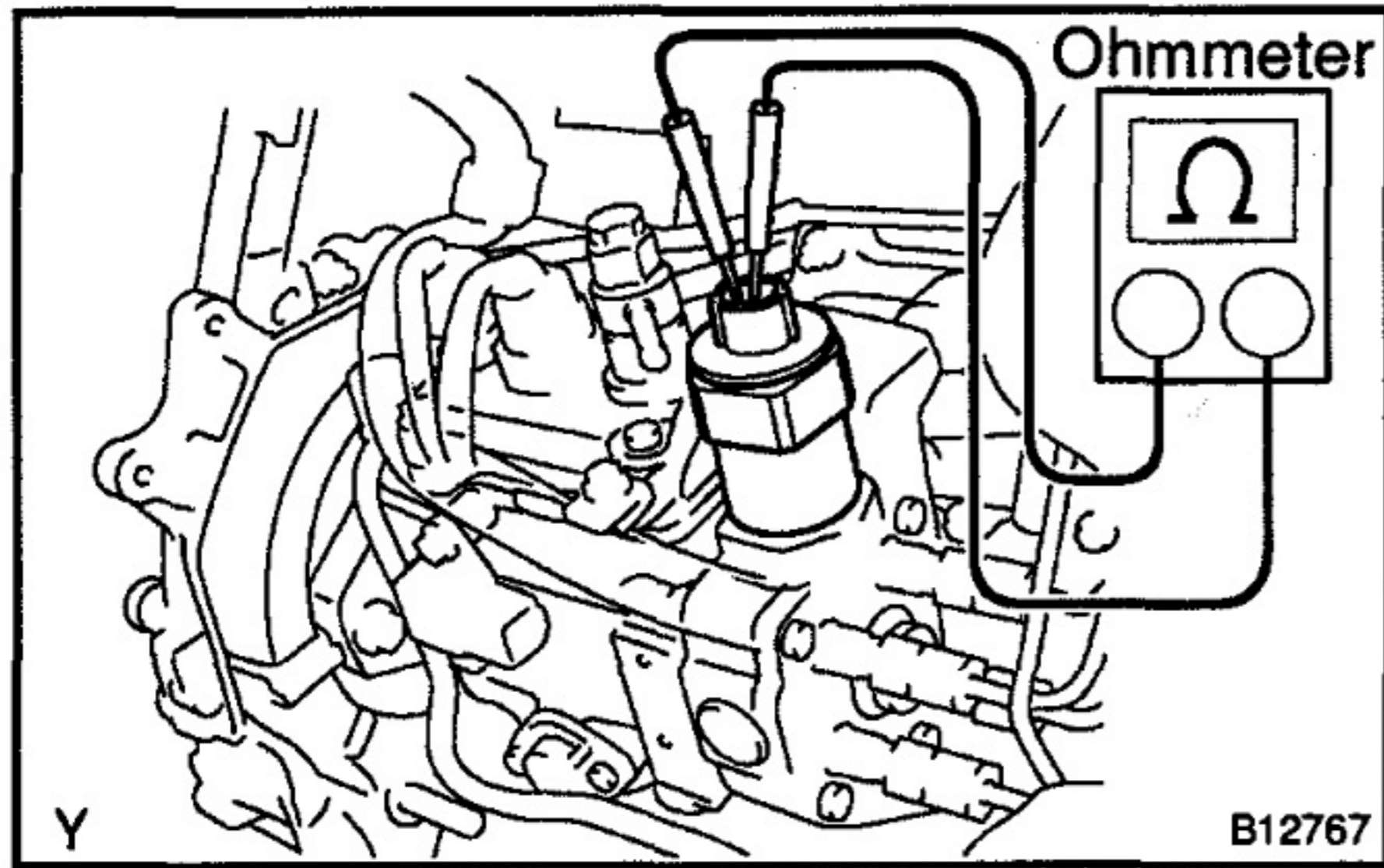

SPILL CONTROL VALVE INSPECTION

ED02U-02

INSPECT SPILL CONTROL VALVE

- (a) Disconnect the valve connector.
- (b) Using an ohmmeter, measure the resistance between the terminals.

Resistance: 1 – 2 Ω at 20°C (68°F)

If the resistance is not specified, replace the injection pump assembly (See page FU-8).

- (c) Reconnect the valve connector.

E-VRV FOR EGR (w/ EGR) COMPONENTS

ED03W-01

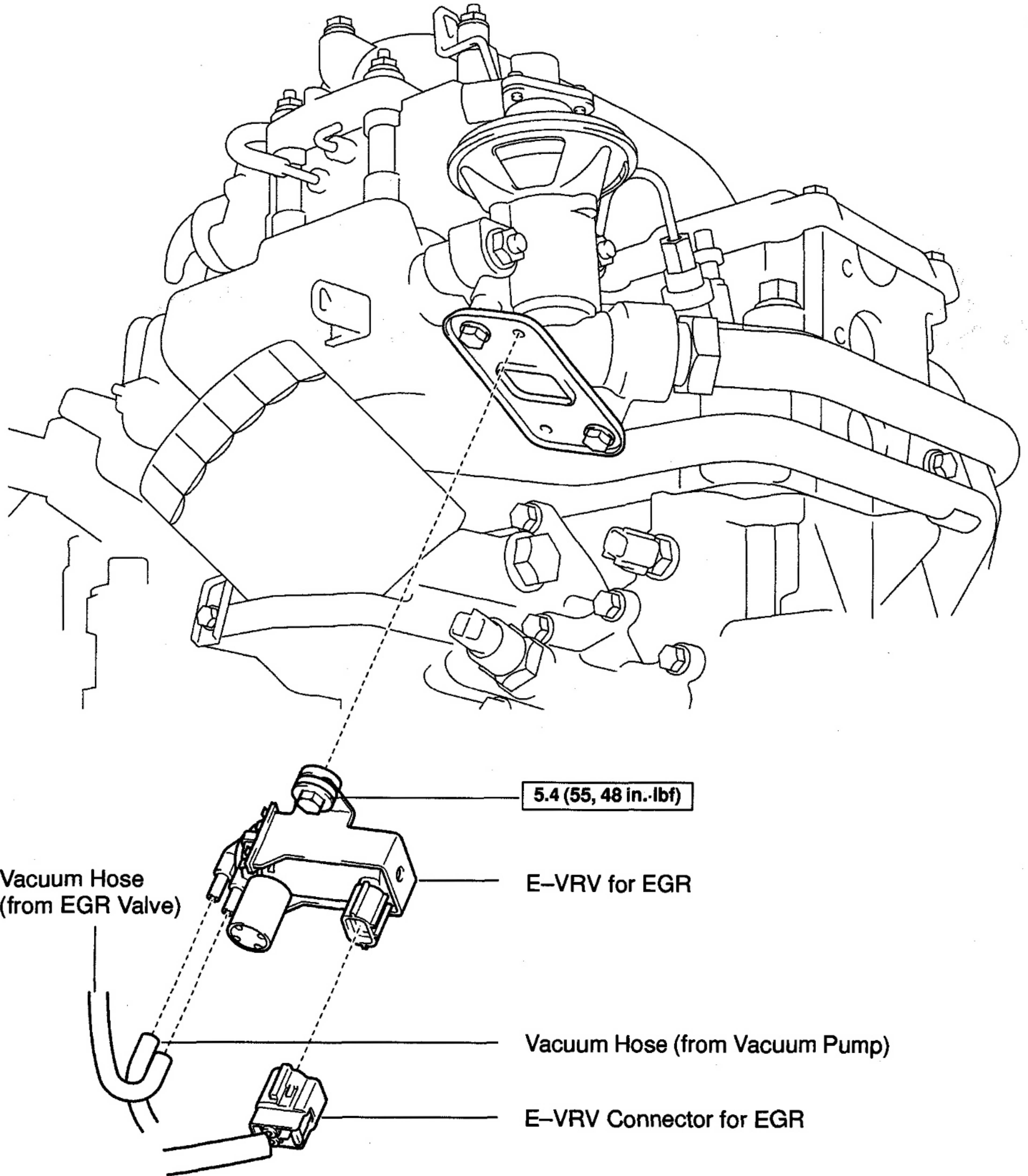

ED

N·m (kgf·cm, ft·lbf) : Specified torque

P

B12962

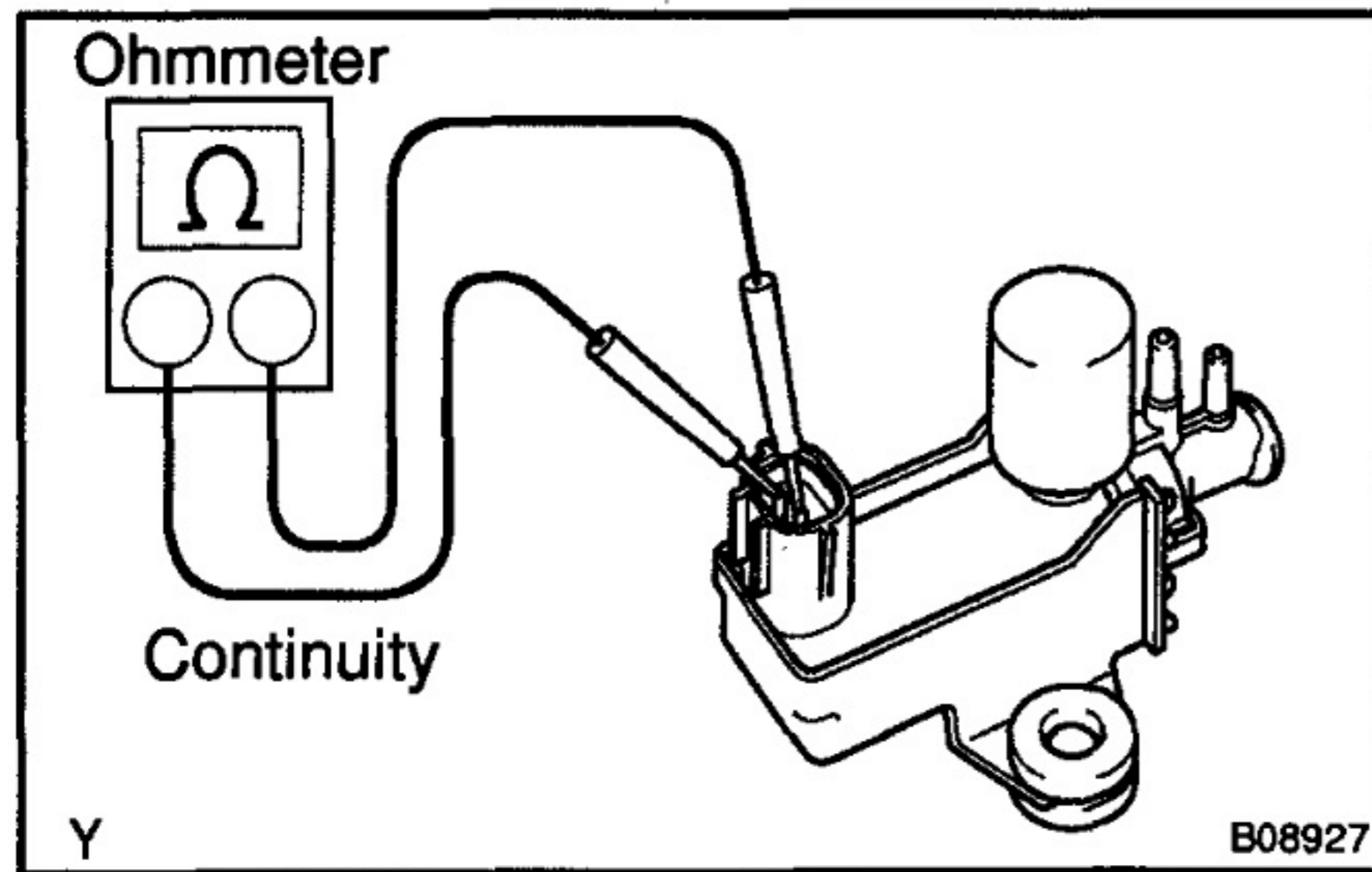

INSPECTION

1. INSPECT E-VRV

- (a) Inspect the E-VRV for open circuit.
Using an ohmmeter, check that there is continuity between the terminals.

Resistance: 11 – 13 Ω at 20°C (68°F)

If there is no continuity, replace the E-VRV.

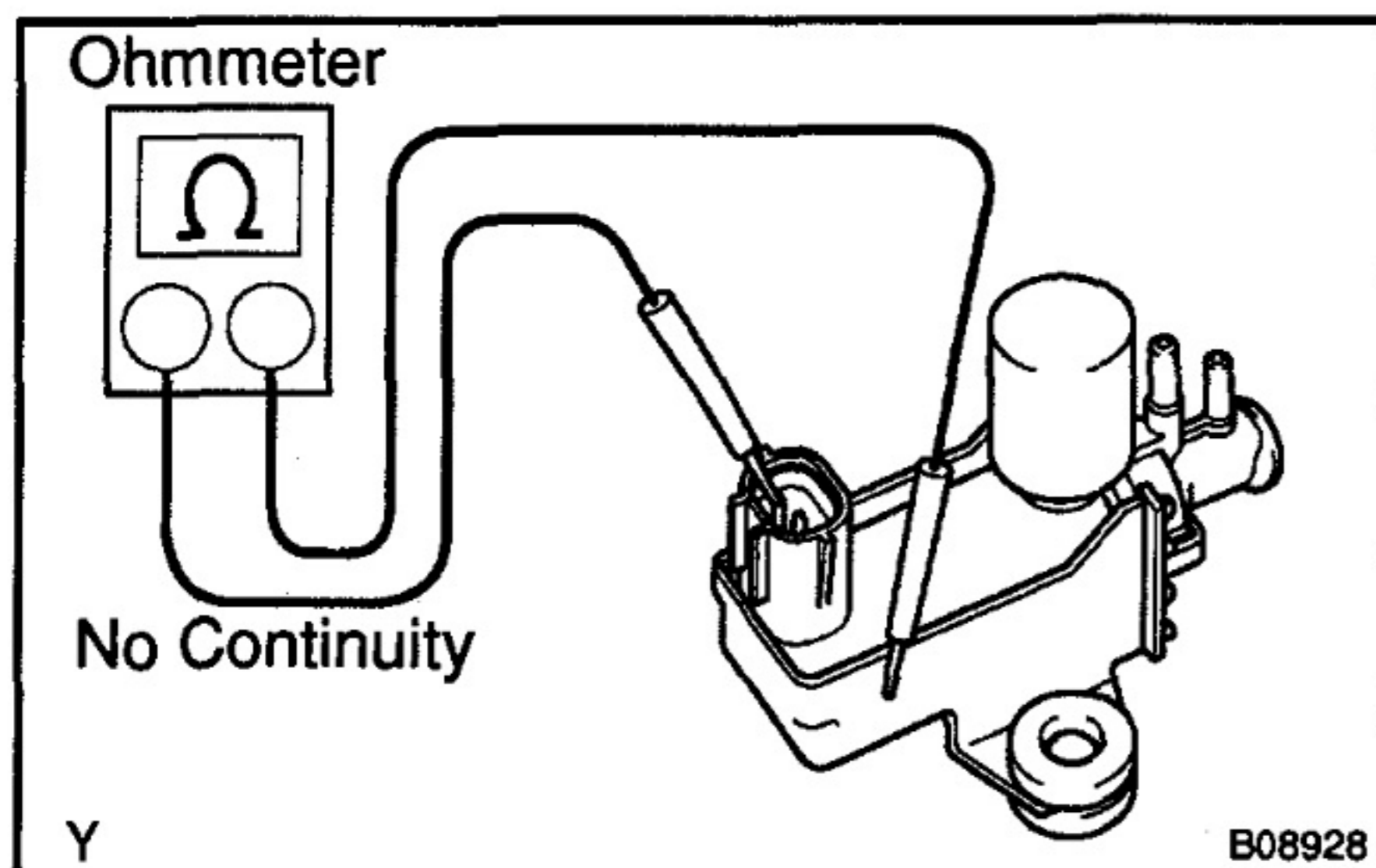

- (b) Inspect the E-VRV for ground.
Using an ohmmeter, check that there is no continuity between each terminal and the body.

If there is continuity, replace the E-VRV.

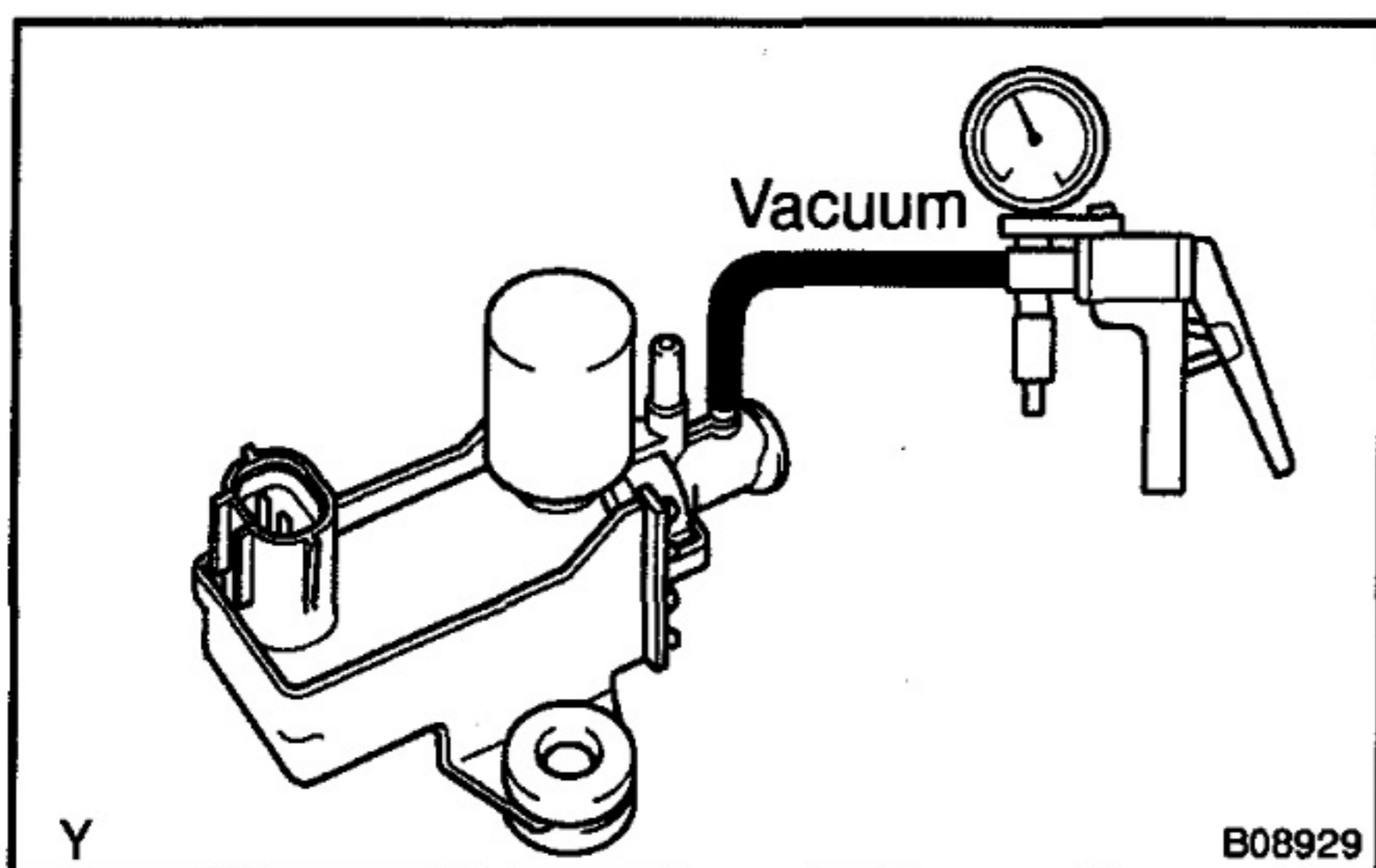

- (c) Inspect the E-VRV for air tightness.
Check that when vacuum is applied to the vacuum outlet port shown, the needle of the vacuum pump indicates an increase of 47 kPa (350 mmHg, 13.9 in. Hg) or more.

If a problem is found, replace the E-VRV.

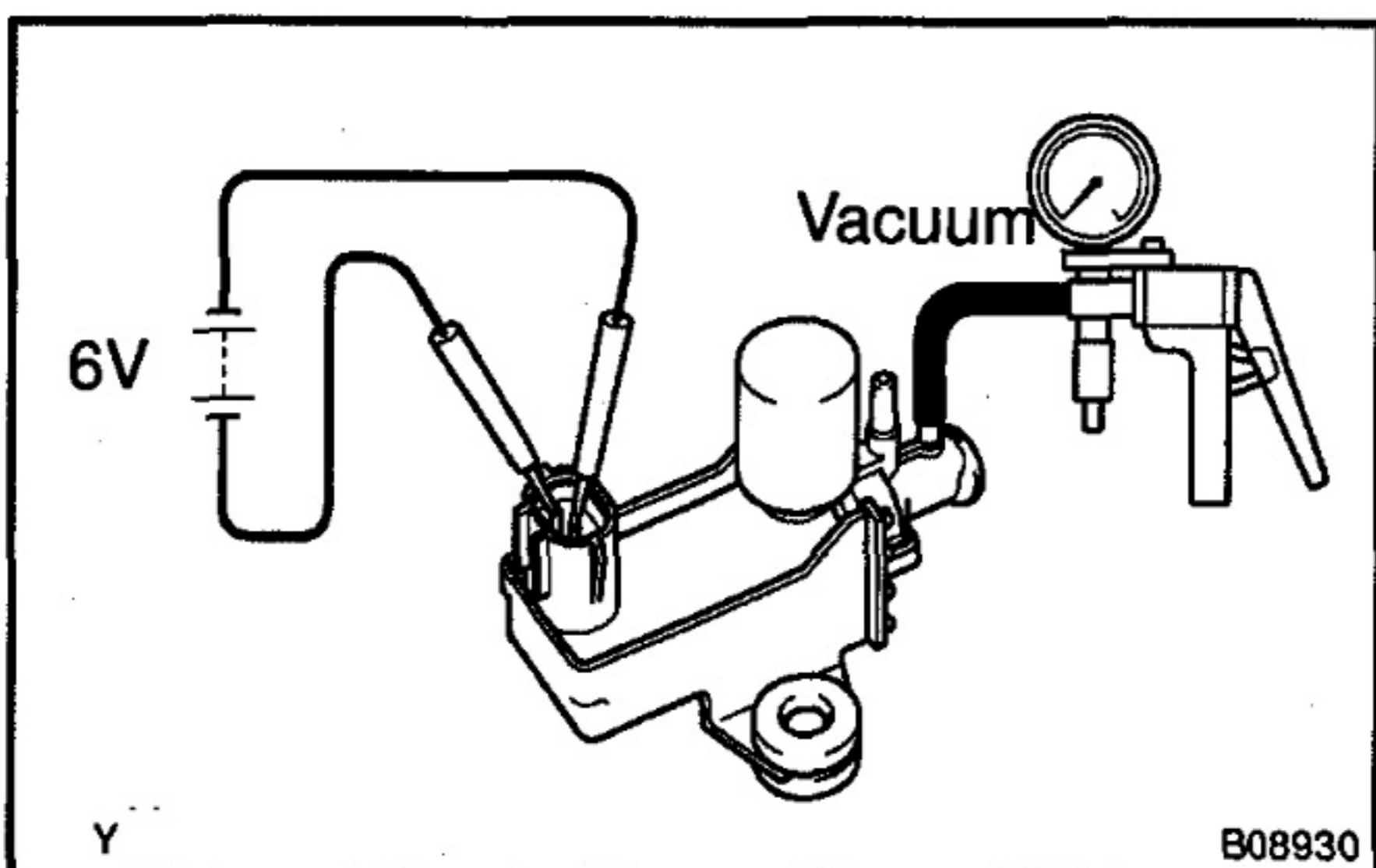

- (d) Inspect the E-VRV operation.

- (1) Apply about 6 V of DC power to the terminals.
- (2) Check that when vacuum is applied to the vacuum outlet port shown, the needle of the vacuum pump does not move.

If operation is not as specified, replace the E-VRV.

2. REINSTALL E-VRV

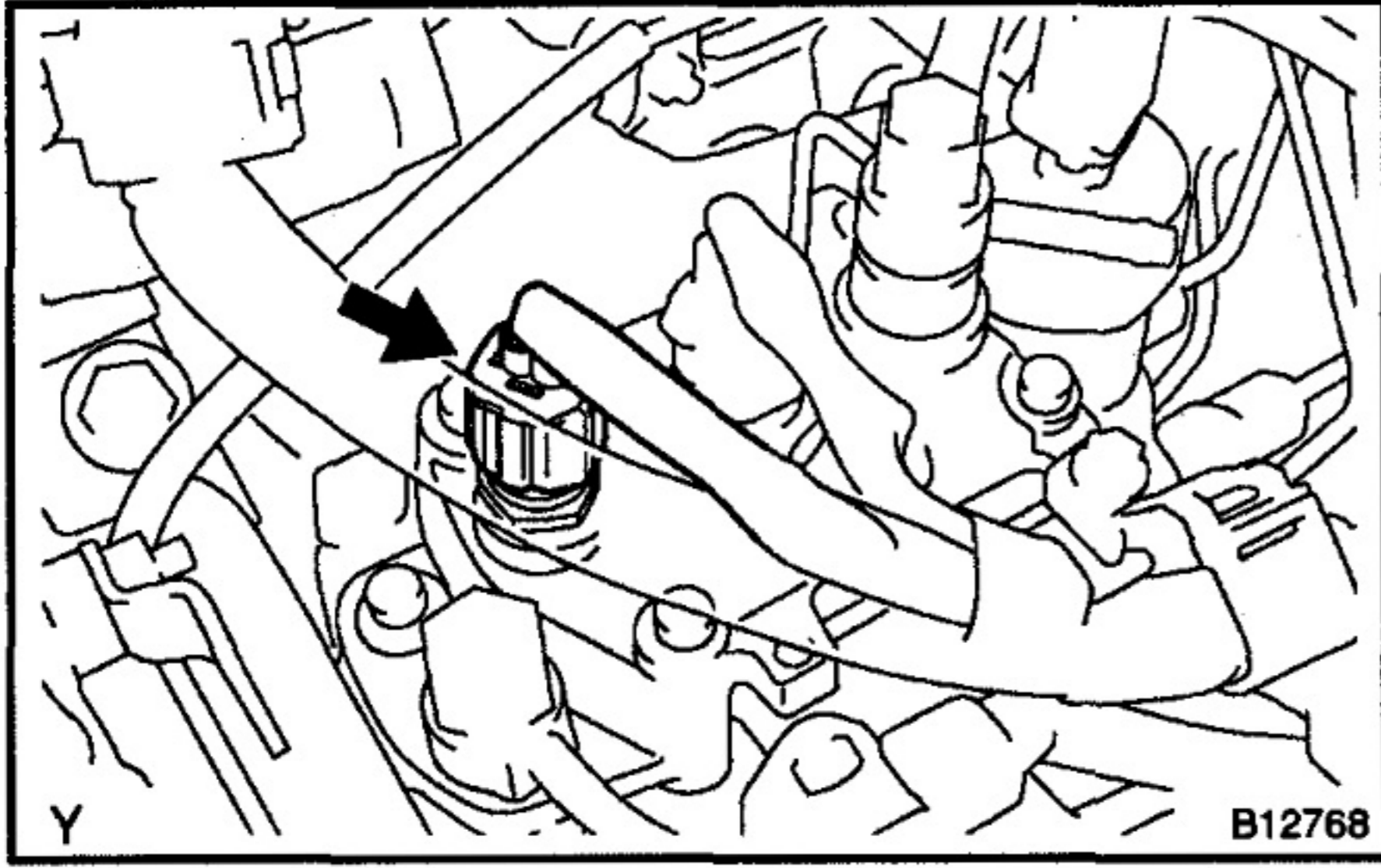

FUEL TEMPERATURE SENSOR INSPECTION

ED040-01

1. REMOVE FUEL TEMPERATURE SENSOR

- (a) Disconnect the sensor connector.
- (b) Using a 19 mm deep socket wrench, remove the sensor and O-ring.

2. INSPECT FUEL TEMPERATURE SENSOR

Using an ohmmeter, measure the resistance between the terminals.

Resistance: Refer to the chart graph

If the resistance is not as specified, replace the sensor.

3. REINSTALL FUEL TEMPERATURE SENSOR

- (a) Install a new O-ring to the sensor.
- (b) Using a 19 mm deep socket wrench, install the sensor.
Torque: 21.6 N·m (220 kgf·cm, 16 ft·lbf)
- (c) Connect the sensor connector.

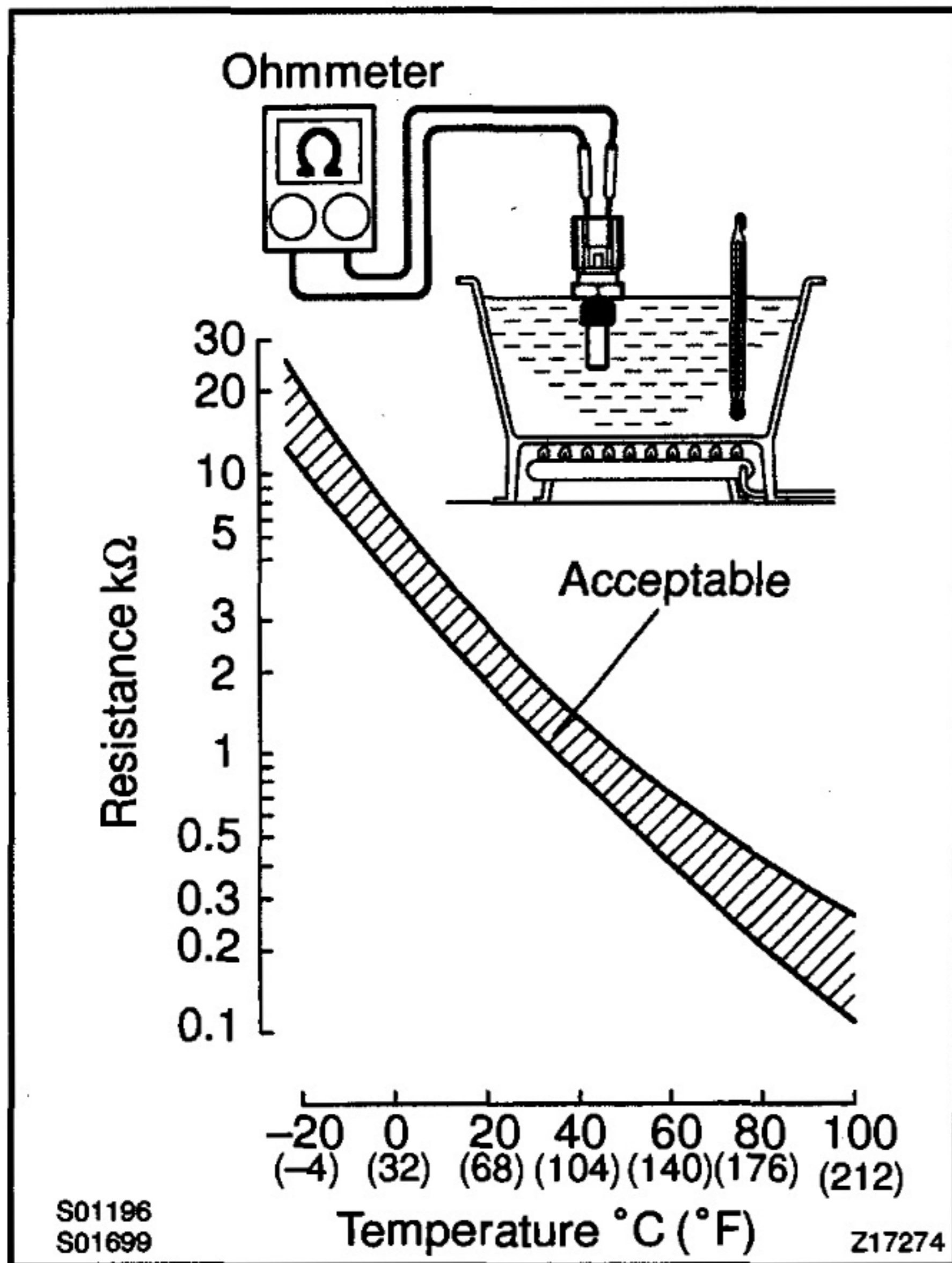

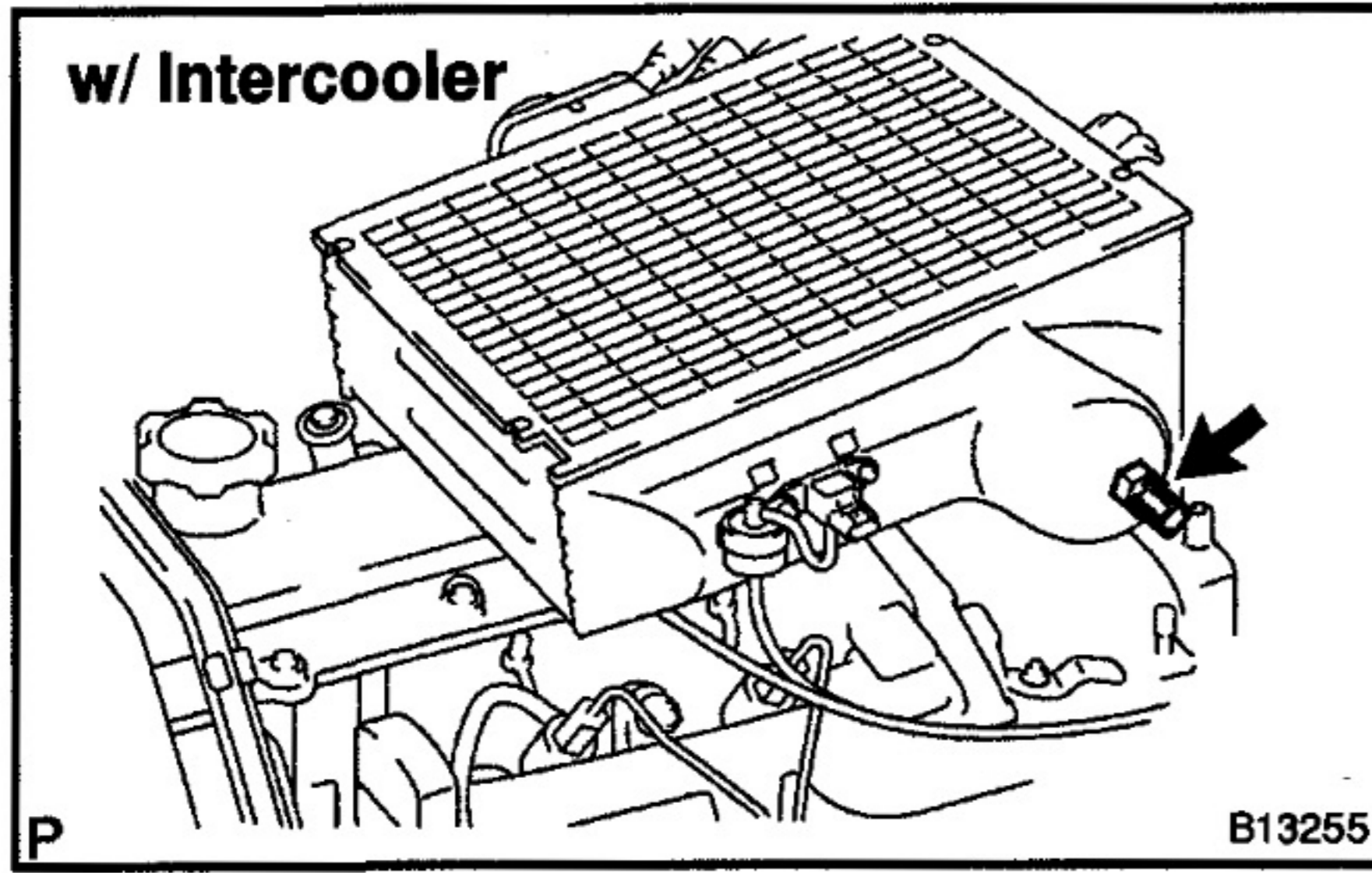

INTAKE AIR TEMPERATURE SENSOR INSPECTION

ED041-01

1. **w/ Intercooler:**
REMOVE INTAKE AIR TEMPERATURE SENSOR
 - (a) Disconnect the sensor connector.
 - (b) Using a 22 mm deep socket wrench, remove the sensor.

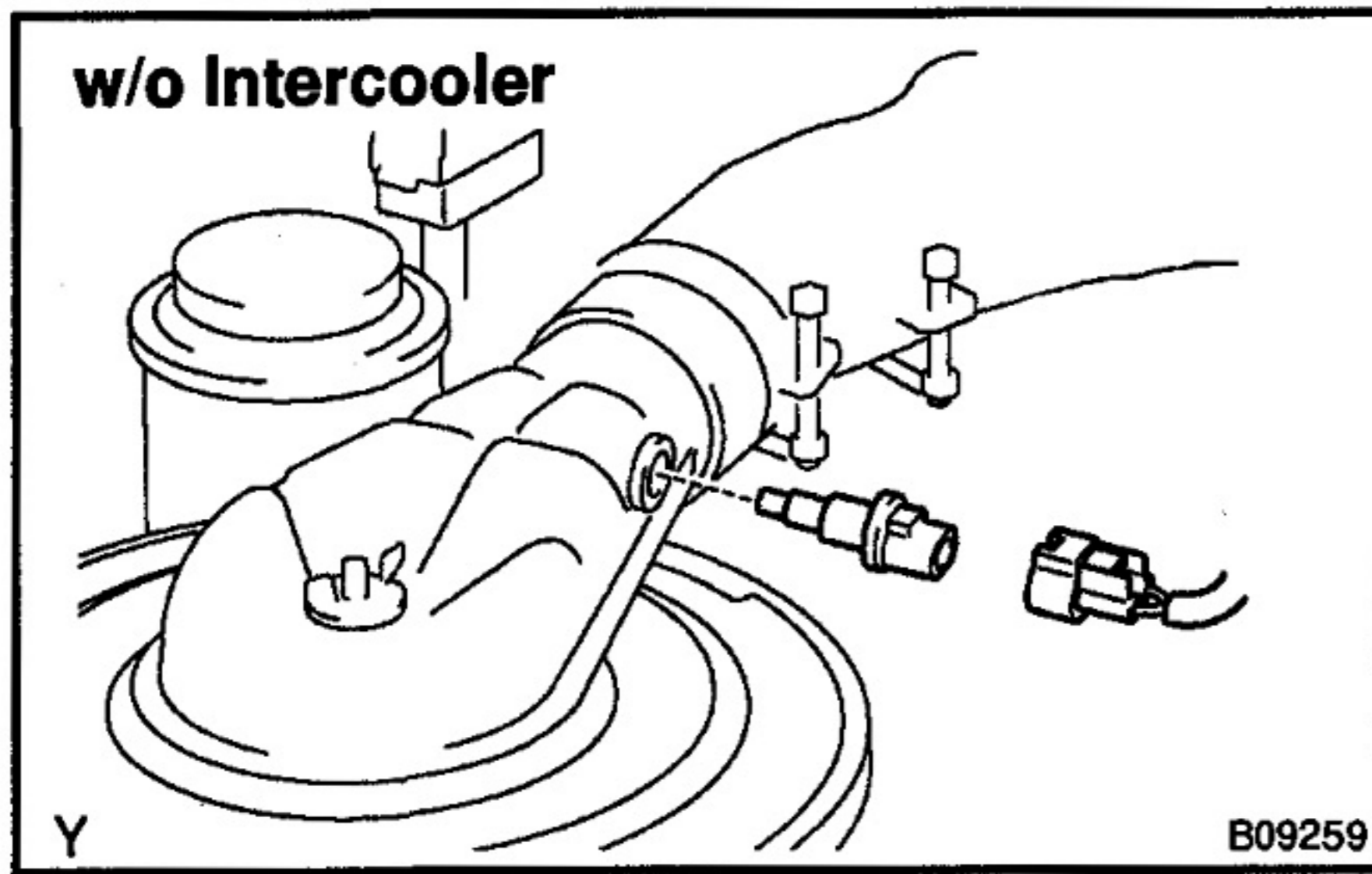

2. **w/o Intercooler:**
REMOVE INTAKE AIR TEMPERATURE SENSOR
 - (a) Disconnect the sensor connector.
 - (b) Remove the sensor.

w/ Intercooler

w/o Intercooler

Resistance kΩ

Temperature °C (°F)	Resistance kΩ
-20 (-4)	30
0 (32)	20
20 (68)	10
40 (104)	5
60 (140)	3
80 (176)	2
100 (212)	1
	0.5
	0.3
	0.2
	0.1

Temperature °C (°F)

Acceptable

S01196
S01195
S01699

B13256

3. **INSPECT INTAKE AIR TEMPERATURE SENSOR**
 Using an ohmmeter, measure the resistance between the terminals.

Resistance: Refer to the chart graph

If the resistance is not as specified, replace the sensor.

4. **w/ Intercooler:**
REINSTALL INTAKE AIR TEMPERATURE SENSOR
 - (a) Using a 22 mm deep socket wrench, install the sensor.
Torque: 29.4 N·m (300 kgf·cm, 20 ft·lbf)
 - (b) Connect the sensor connector.
5. **w/o Intercooler:**
REINSTALL INTAKE AIR TEMPERATURE SENSOR

TURBO PRESSURE SENSOR COMPONENTS

ED042-01

w/ Intercooler (Land Cruiser/Land Cruiser Prado for Australia)

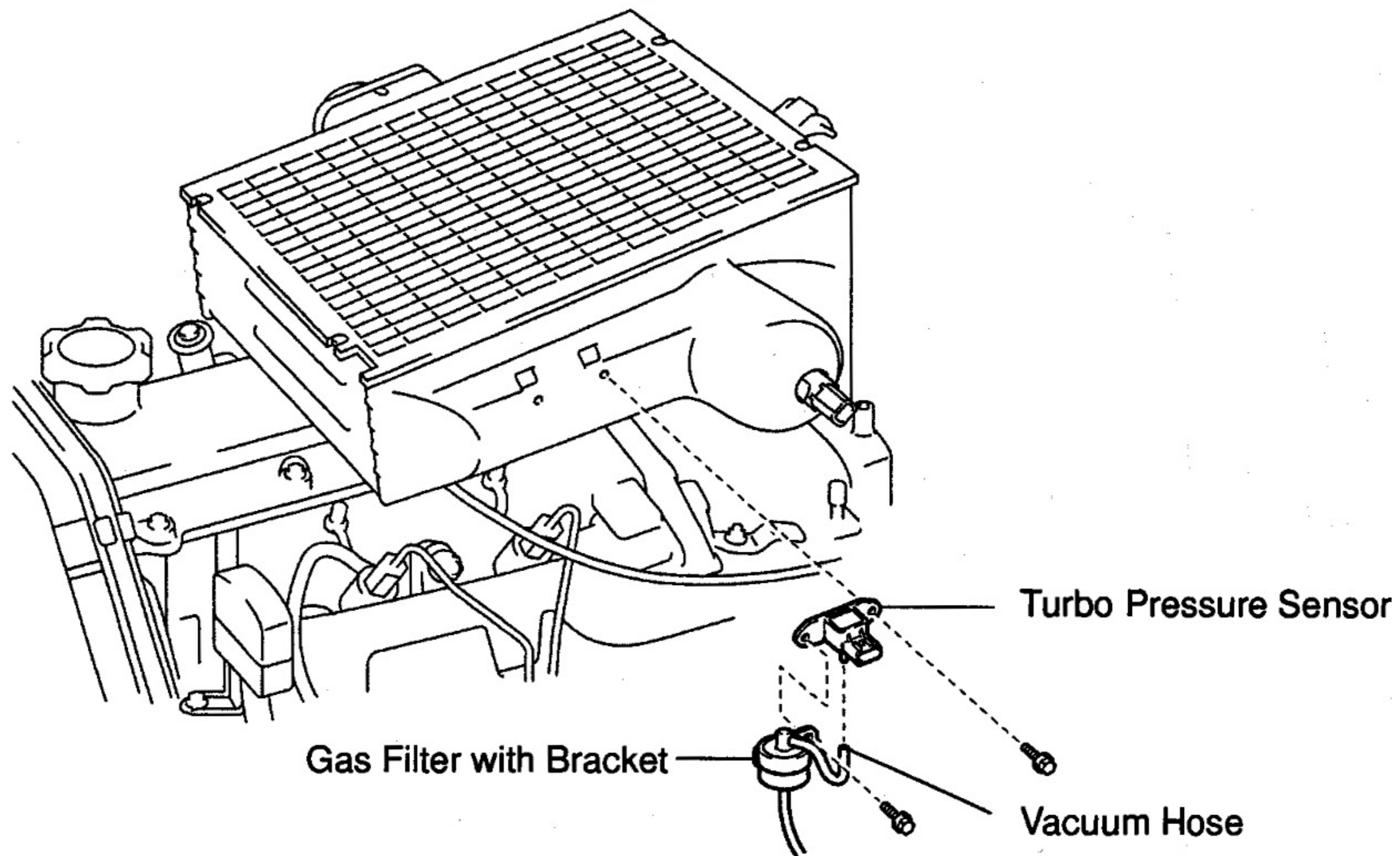

P

B13254

w/o Intercooler

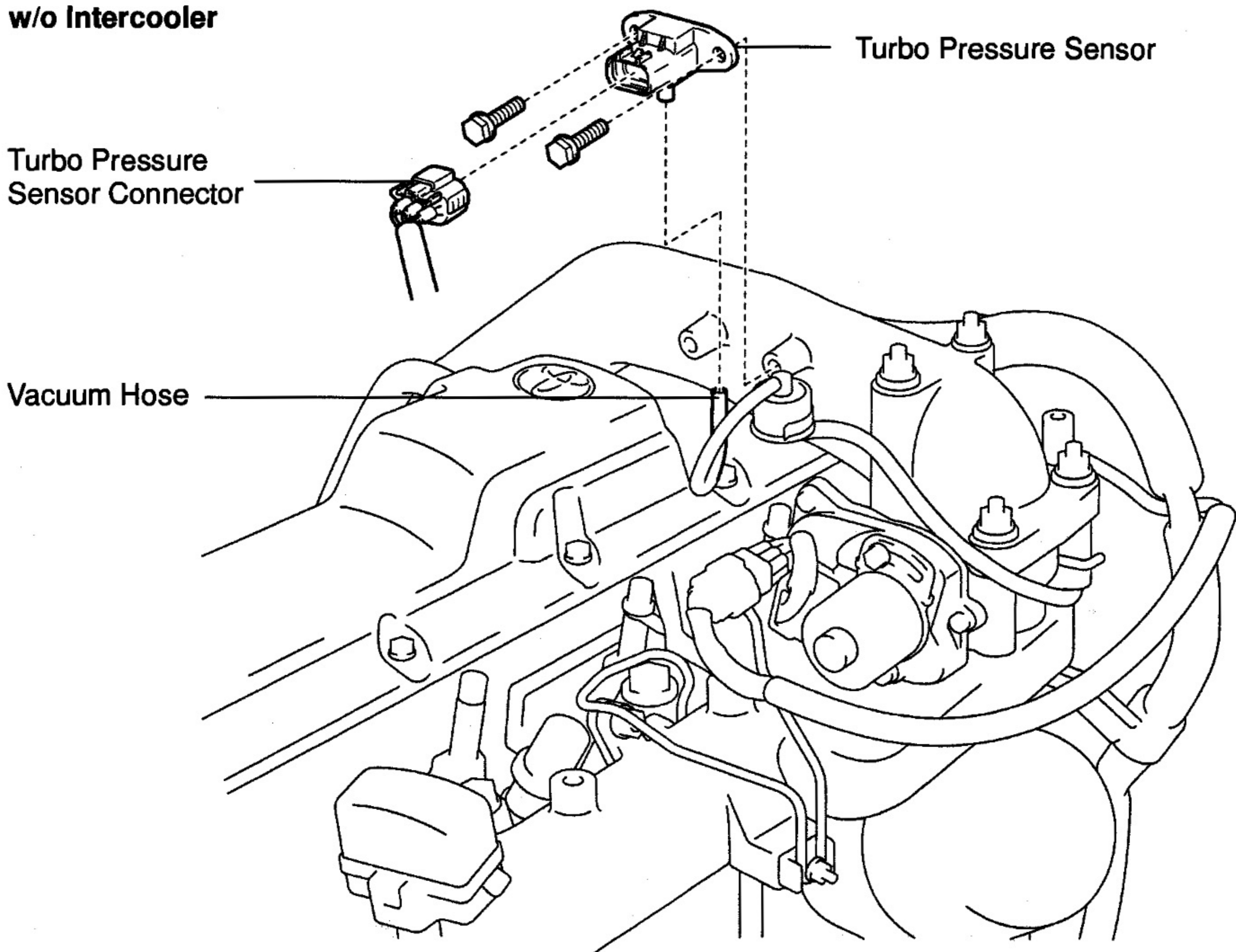

P

B12967

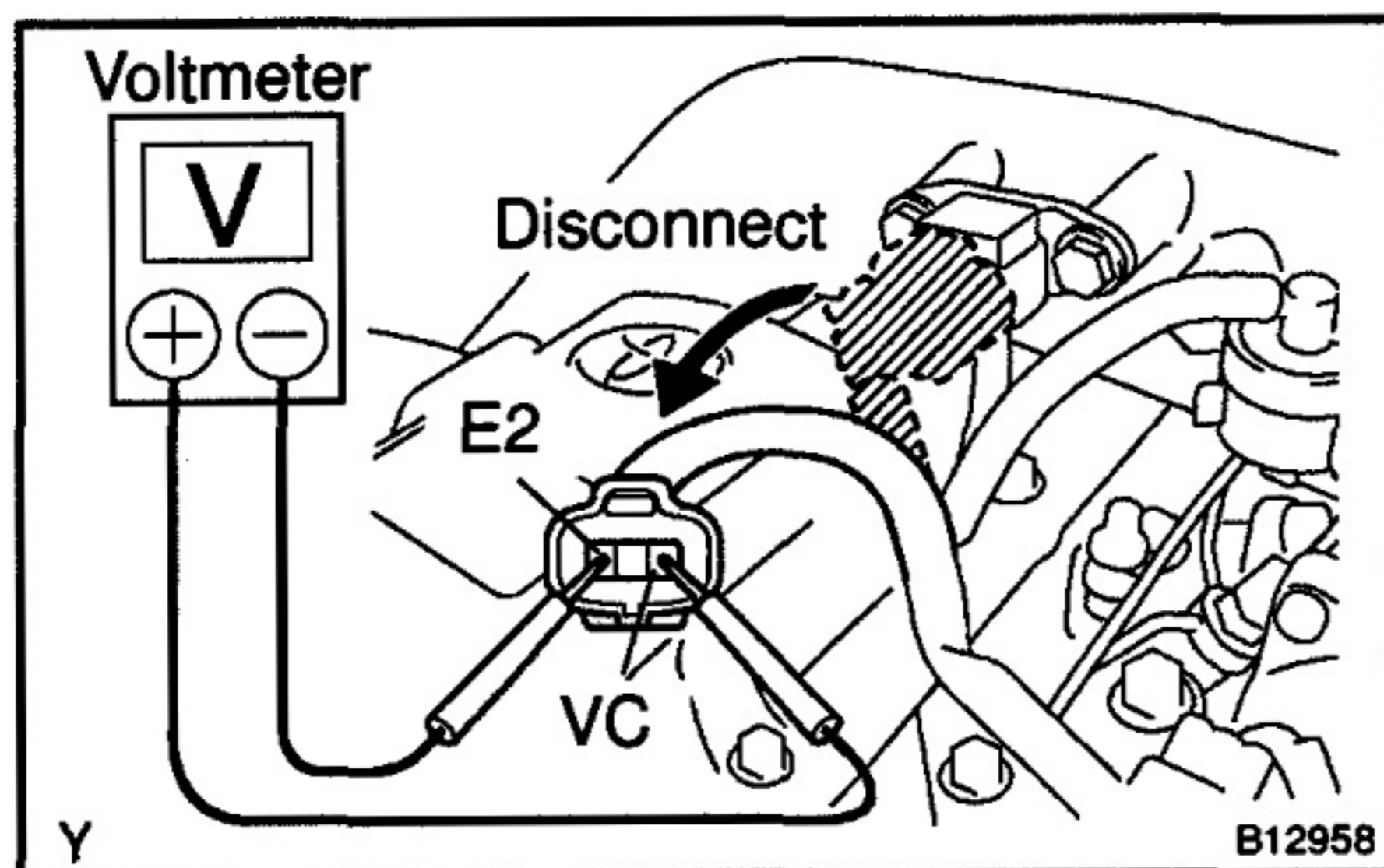

INSPECTION

1. INSPECT POWER SOURCE VOLTAGE OF TURBO PRESSURE SENSOR

- (a) Disconnect the sensor connector.
- (b) Turn the ignition switch ON.
- (c) Using a voltmeter, measure the voltage between connector terminals VC and E2 of the wiring harness side.

Voltage: 4.5 – 5.5 V

- (d) Turn the ignition switch OFF.
- (e) Reconnect the sensor connector.

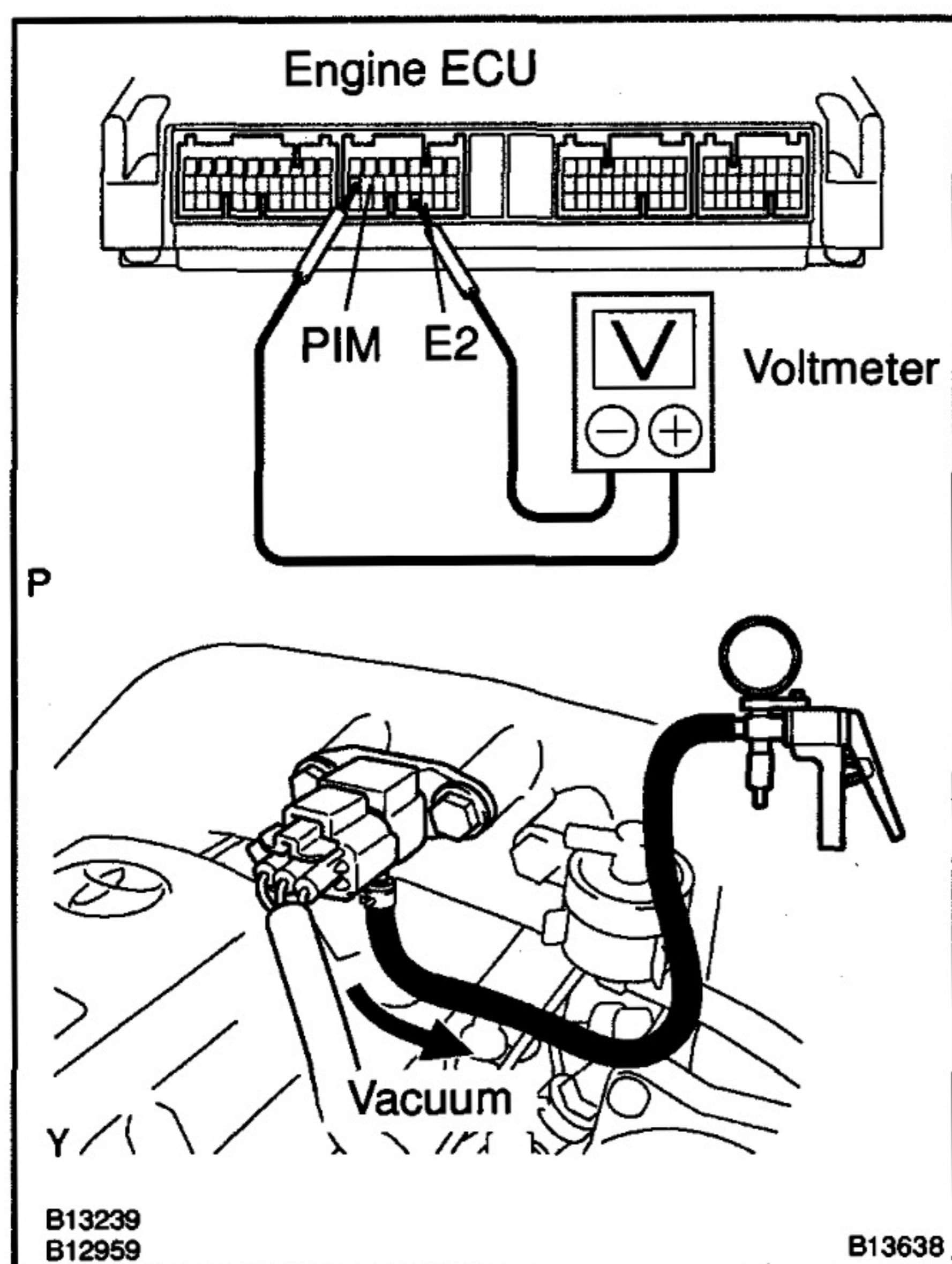

2. INSPECT POWER OUTPUT OF TURBO PRESSURE SENSOR

- (a) Turn the ignition switch ON.
- (b) Disconnect the vacuum hose from the sensor.
- (c) Connect a voltmeter to terminals PIM and E2 of the engine ECU, and measure the output voltage under ambient atmospheric pressure.
- (d) Apply vacuum to the sensor in 13.3 kPa (100 mmHg, 3.94 in.Hg) segments to 40.0 kPa (300 mmHg, 11.81 in.Hg).
- (e) Measure the voltage drop from step (c) above for each segment.

Voltage drop:

Applied vacuum kPa (mmHg, in.Hg)	Voltage drop V
13.3 (100, 3.94)	0.3 – 0.5
26.7 (200, 7.87)	0.6 – 0.8
40.0 (300, 11.81)	0.95 – 1.15

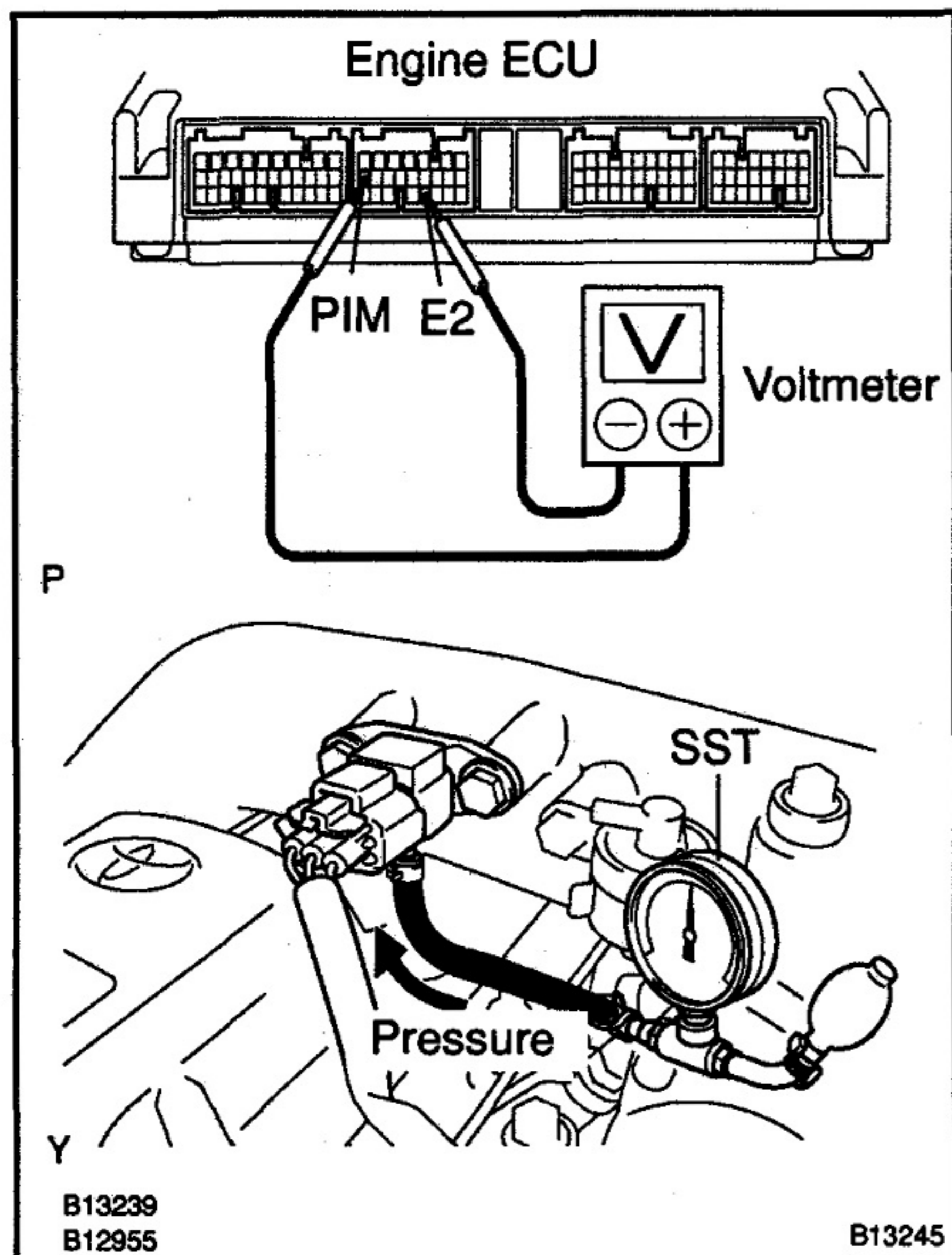

(f) Using SST (turbocharger pressure gauge), apply pressure to the sensor in 19.6 kPa (0.20 kgf/cm², 2.84 psi) segments to 98.0 kPa (1.00 kgf/cm², 14.2 psi).

SST 09992-00242

(g) Measure the voltage up from step (c) above for each segment.

Voltage up:

Applied pressure kPa (kgf/cm ² , psi)	Voltage up V
19.6 (0.20, 2.84)	0.4 - 0.7
39.2 (0.40, 5.69)	0.9 - 1.2
58.8 (0.60, 8.53)	1.5 - 1.8
78.5 (0.80, 11.4)	2.0 - 2.3
98.0 (1.00, 14.2)	2.5 - 2.8

(h) Reconnect the vacuum hose to the sensor.

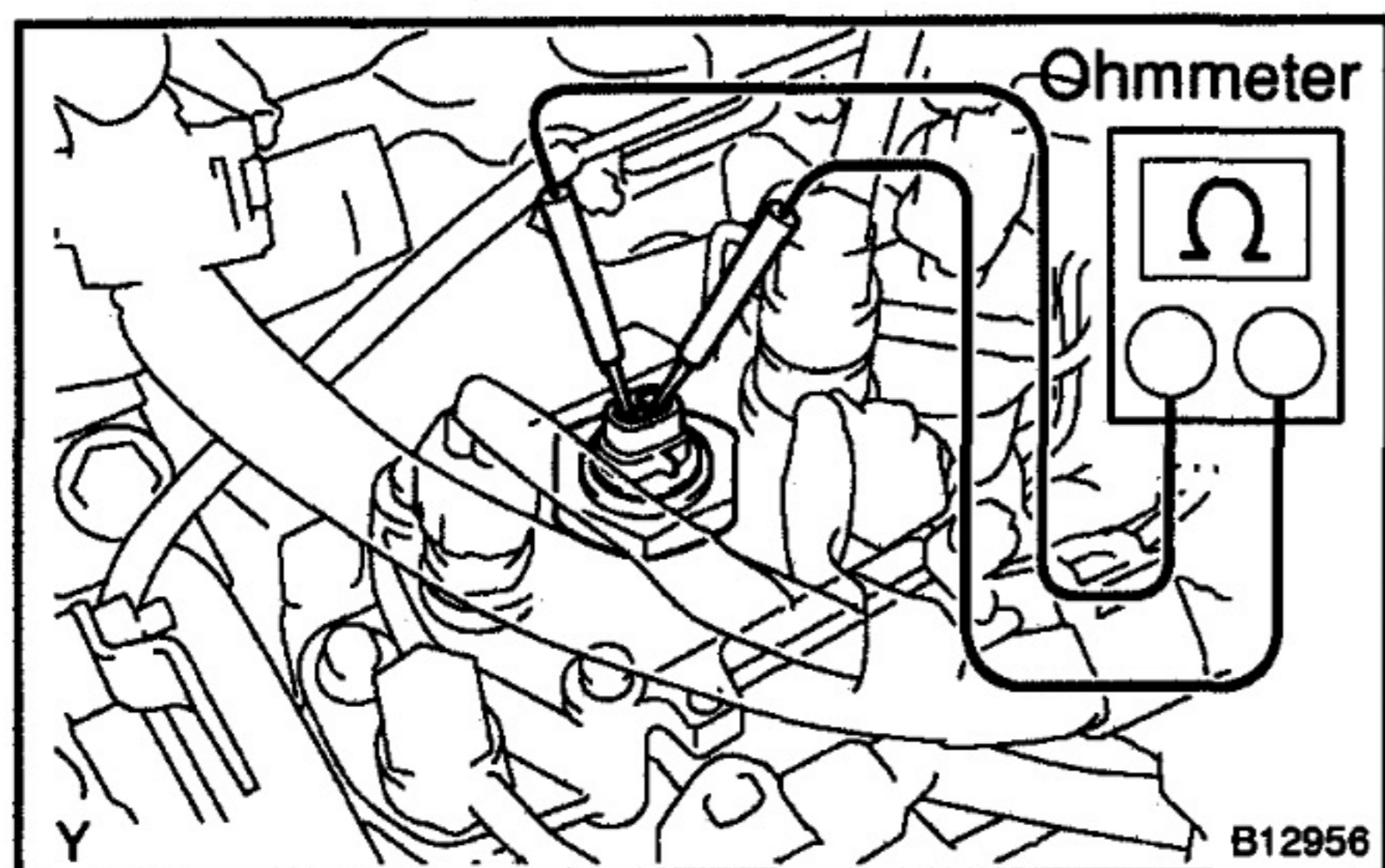

ENGINE SPEED SENSOR INSPECTION

ED03F-02

INSPECT ENGINE SPEED SENSOR

- (a) Disconnect the sensor connector.
- (b) Using an ohmmeter, measure the resistance between the terminals.

Resistance: 205 – 255 Ω at 20° C (68° F)

If the resistance is not specified, replace the injection pump assembly (See page FU-8).

- (c) Reconnect the sensor connector.

ACCELERATOR PEDAL POSITION SENSOR COMPONENTS

ED043-01

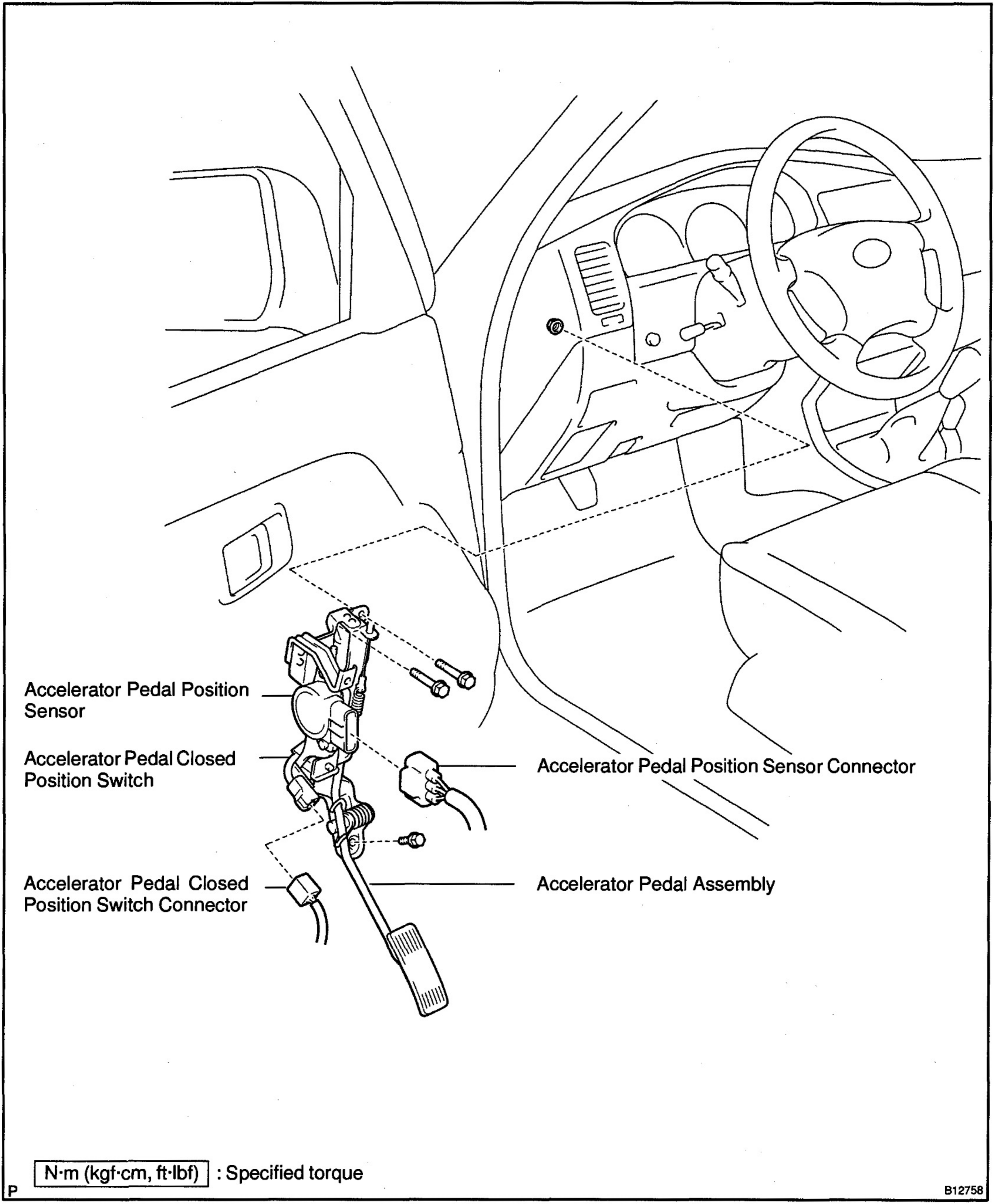

INSPECTION

INSPECT ACCELERATOR PEDAL POSITION SENSOR (See page DI-42)

If necessary, replace the accelerator pedal assembly.

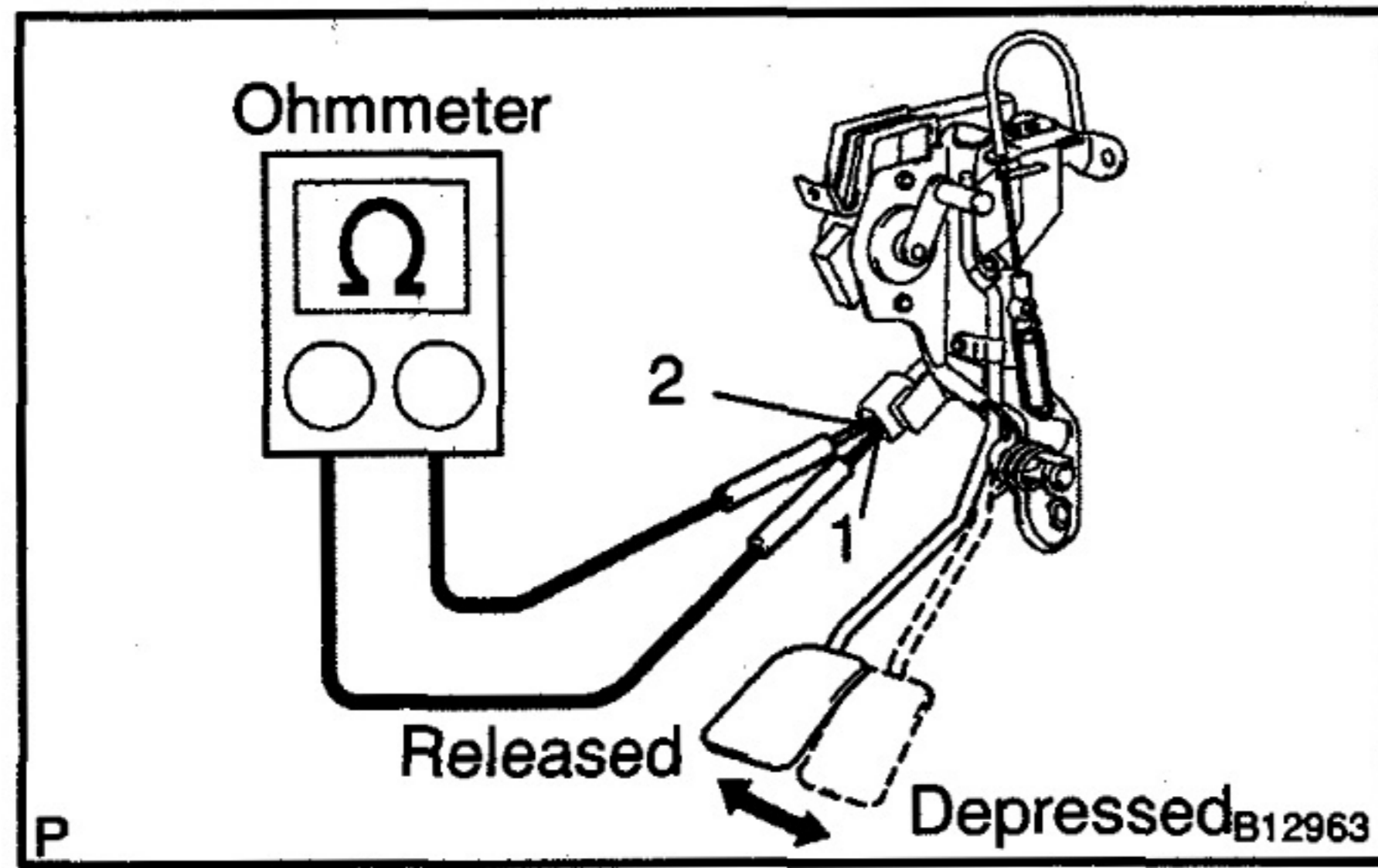

ACCELERATOR PEDAL CLOSED POSITION SWITCH INSPECTION

ED038-02

INSPECT ACCELERATOR PEDAL CLOSED POSITION SWITCH

- (a) Disconnect the switch connector.
- (b) Using an ohmmeter, check the continuity between the terminals.

Continuity:

Accelerator Pedal	Continuity
Released	Continuity (0 – 20 Ω)
Depressed	No continuity

If the continuity is not as specified, replace the accelerator pedal assembly (See page ED-18).

- (c) Reconnect the switch connector.

FIRST GEAR POSITION SWITCH (M/T)

ED03Y-01

INSPECTION

INSPECT FIRST GEAR POSITION SWITCH

- (a) Disconnect the switch connector.
- (b) Using an ohmmeter, check the switch continuity.

Continuity:

Transmission Shift Position	Specified continuity
1	Continuity
Others	No continuity

If the continuity is not as specified, replace the switch.

- (c) Reconnect the switch connector.

REPLACEMENT

1. **REMOVE TRANSMISSION**
2. **REMOVE FIRST GEAR POSITION SWITCH**
 - (a) Using SST, remove the switch and gasket.
SST 09817-16011
 - (b) Remove the gasket from the switch.
3. **REINSTALL NEW FIRST GEAR POSITION SWITCH**
 - (a) Install a new gasket to the switch.
 - (b) Using SST, install the switch.
Torque: 30 N·m (306 kgf·cm, 22.1 ft·lbf)
SST 09817-16011
4. **REINSTALL TRANSMISSION**

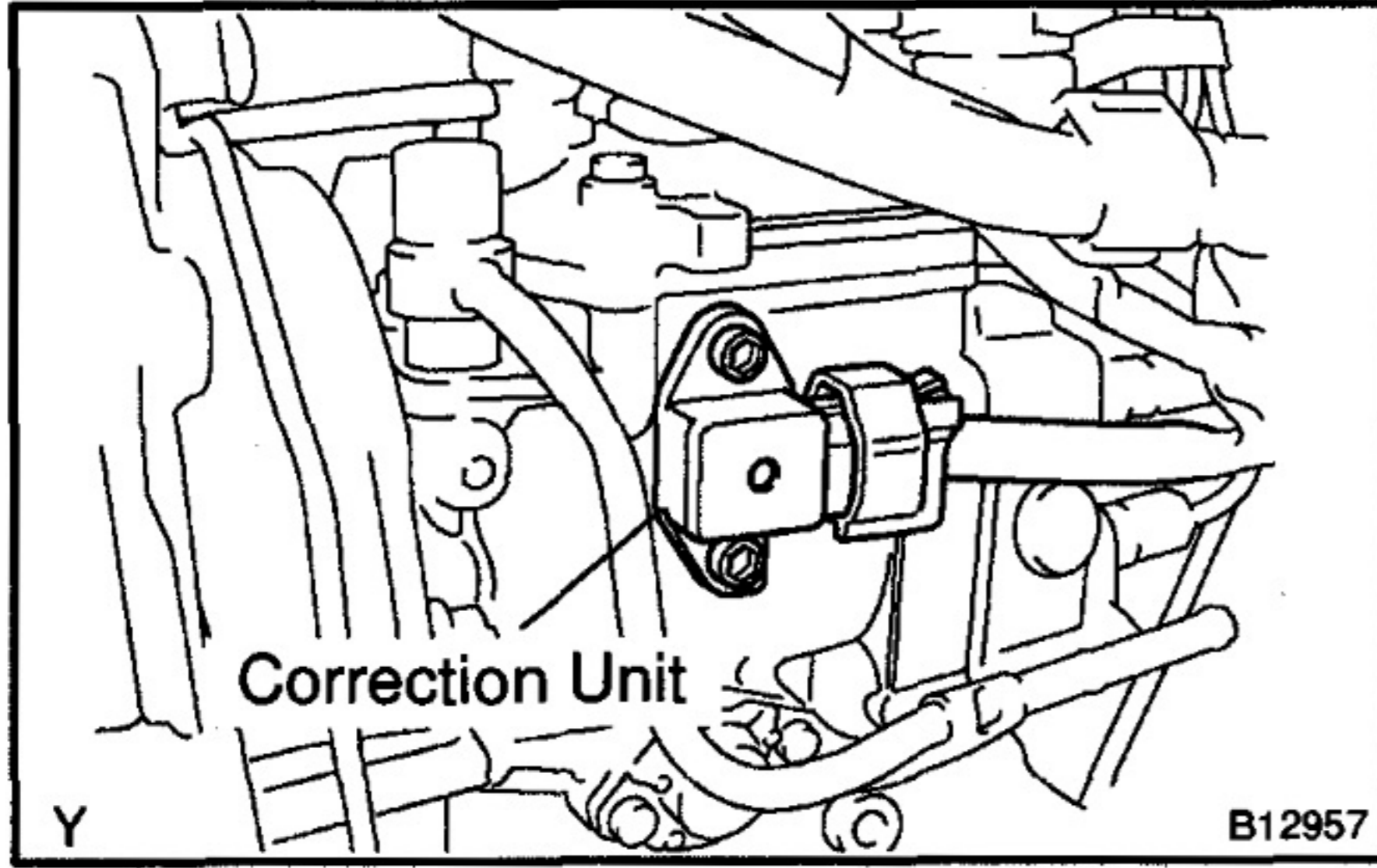

INJECTION PUMP CORRECTION UNIT

ED03B-02

INSPECTION

INSPECT INJECTION PUMP CORRECTION UNIT (See page DI-69)

If necessary, replace the injection pump assembly (See page FU-8).

ENGINE FUEL

FUEL HEATER	FU-1
INJECTION NOZZLE	FU-3
INJECTION PUMP	FU-5

REFER TO FOLLOWING REPAIR MANUALS:

Manual Name	Pub. No.
1KZ-T Engine Repair Manual	RM353E
1KZ-TE Engine Repair Manual	RM710E
1KZ-T, 1KZ-TE Engine Repair Manual Supplement	RM522E

NOTE: The above pages contain only the points which differ from the above listed manuals.

FUEL HEATER COMPONENTS

FU08L-01

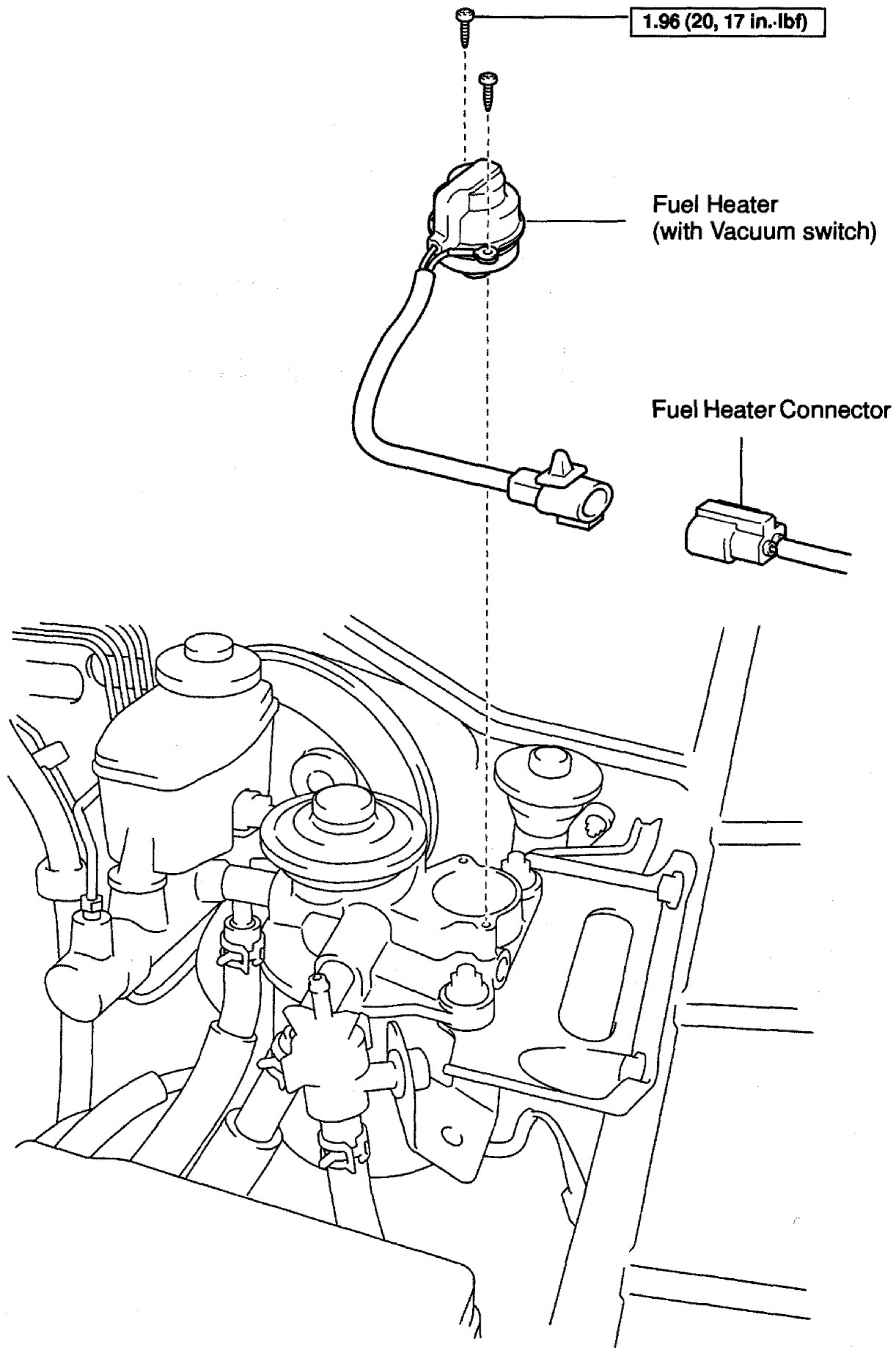

FU

N·m (kgf·cm, ft·lbf) : Specified torque

P

B13125

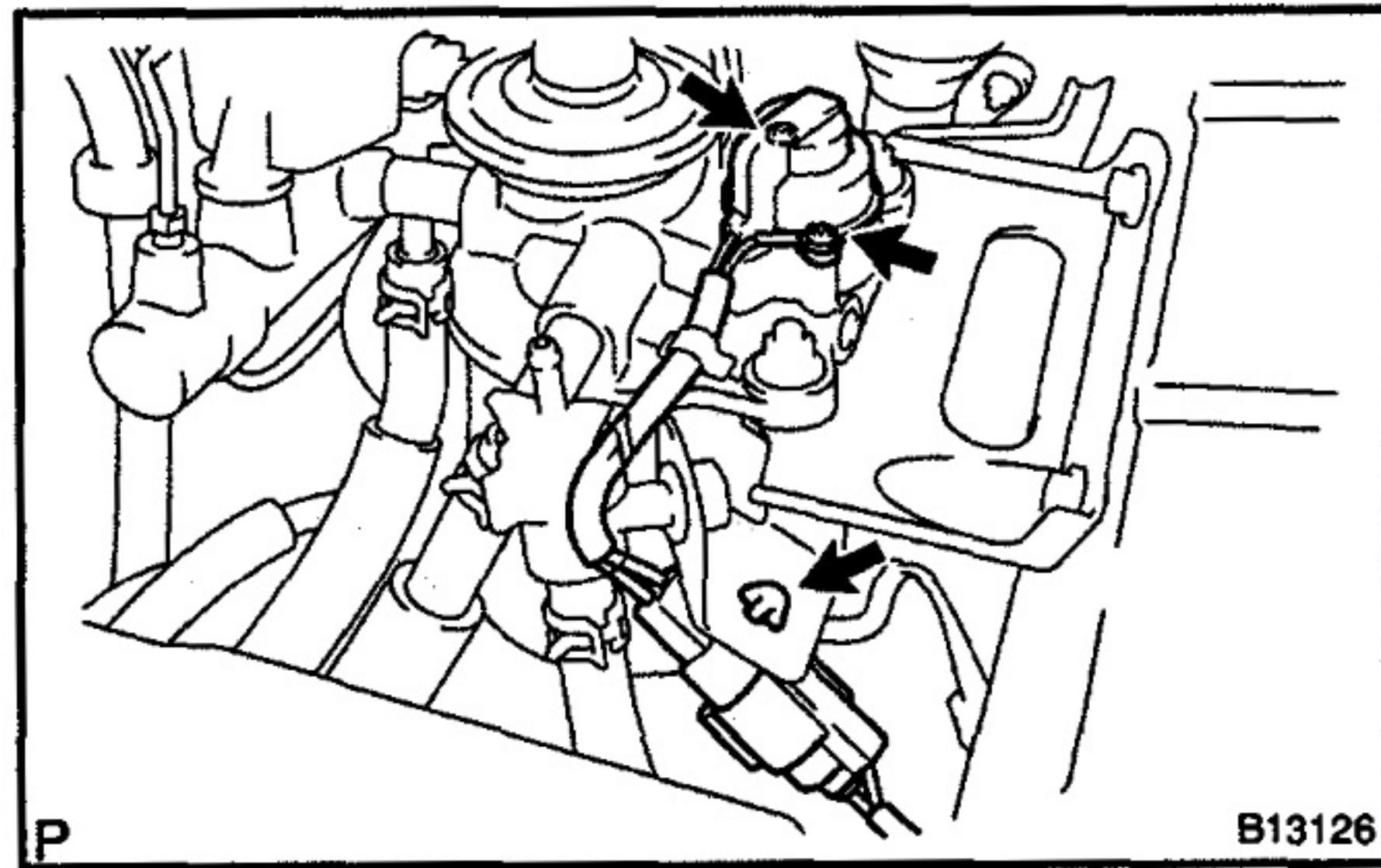

INSPECTION

1. REMOVE FUEL HEATER

- (a) Disconnect the fuel heater connector.
- (b) Remove the 2 screws and fuel heater.

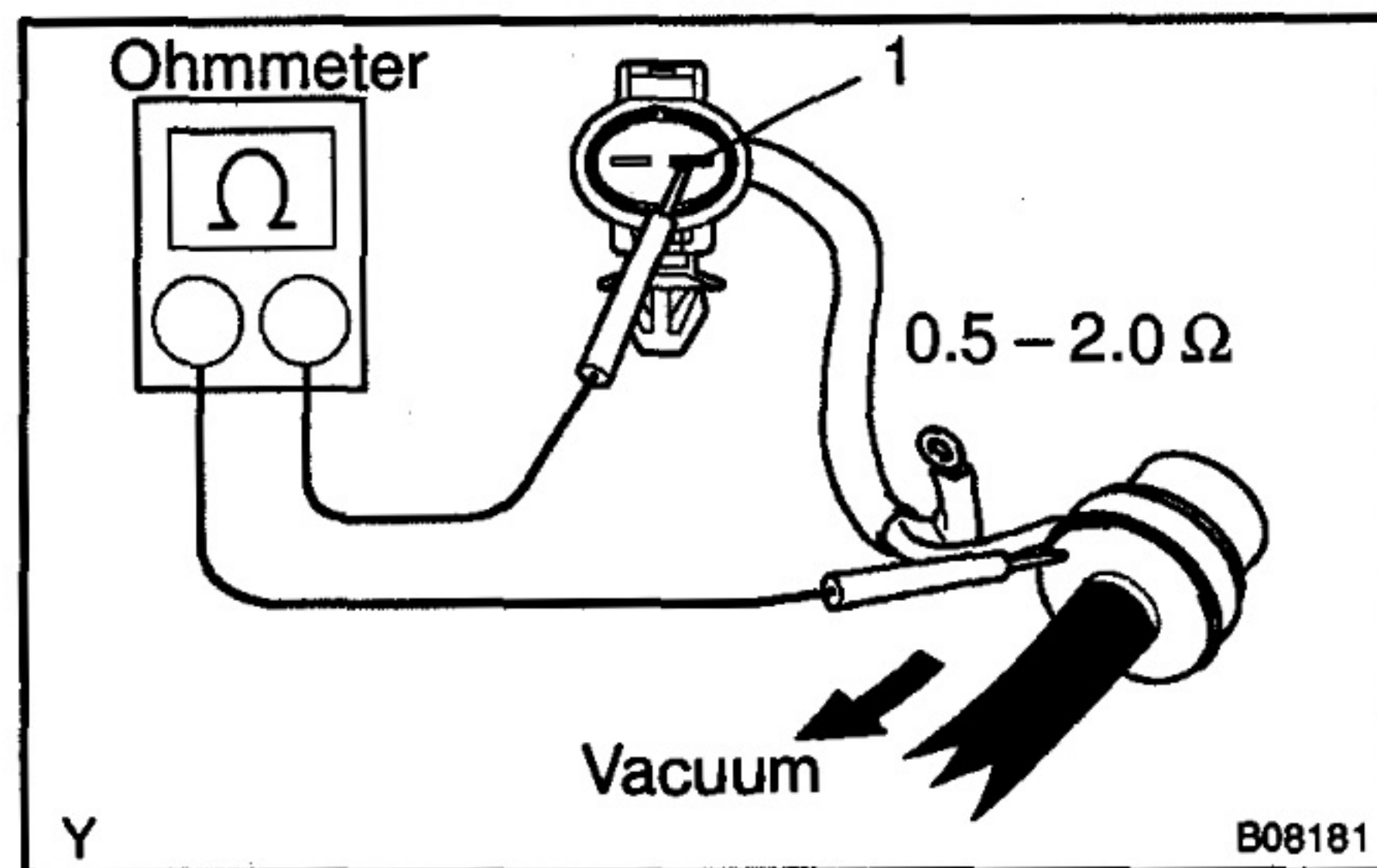

2. INSPECT FUEL HEATER

- (a) Inspect the fuel heater resistance.
 - (1) Apply a vacuum of 34.7 ± 5.3 kPa (260 ± 40 mmHg, 10.24 ± 1.57 in.Hg) or more to the vacuum switch port.
 - (2) Using an ohmmeter, measure the resistance between terminal 1 and the switch body.

Resistance: $0.5 - 2.0 \Omega$ at 20°C (68°F)

If the resistance is not as specified, replace the fuel heater.

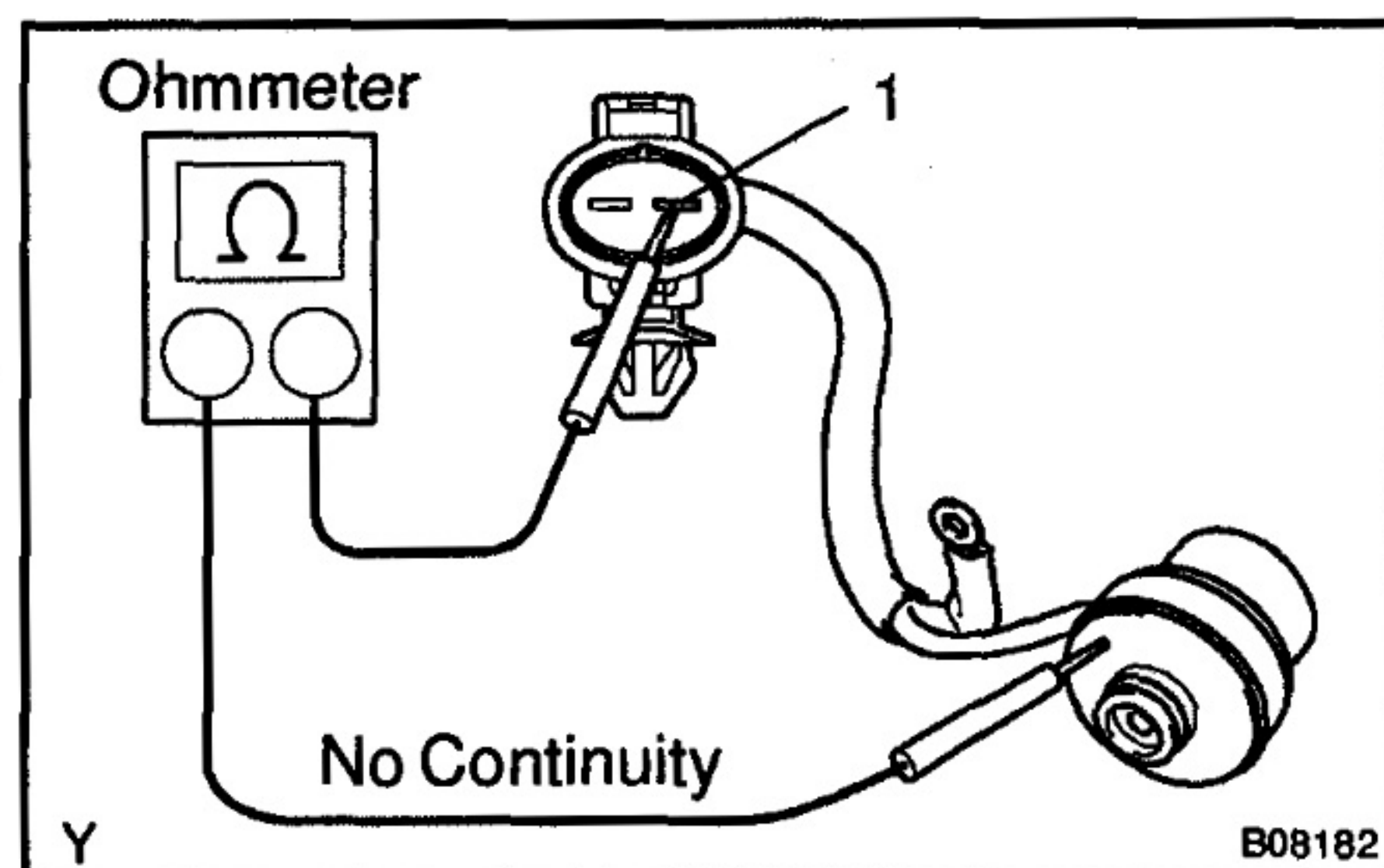

- (b) Inspect the vacuum switch continuity. Using an ohmmeter, check that there is no continuity between terminal 1 and the switch body.

If continuity is not as specified, replace the fuel heater.

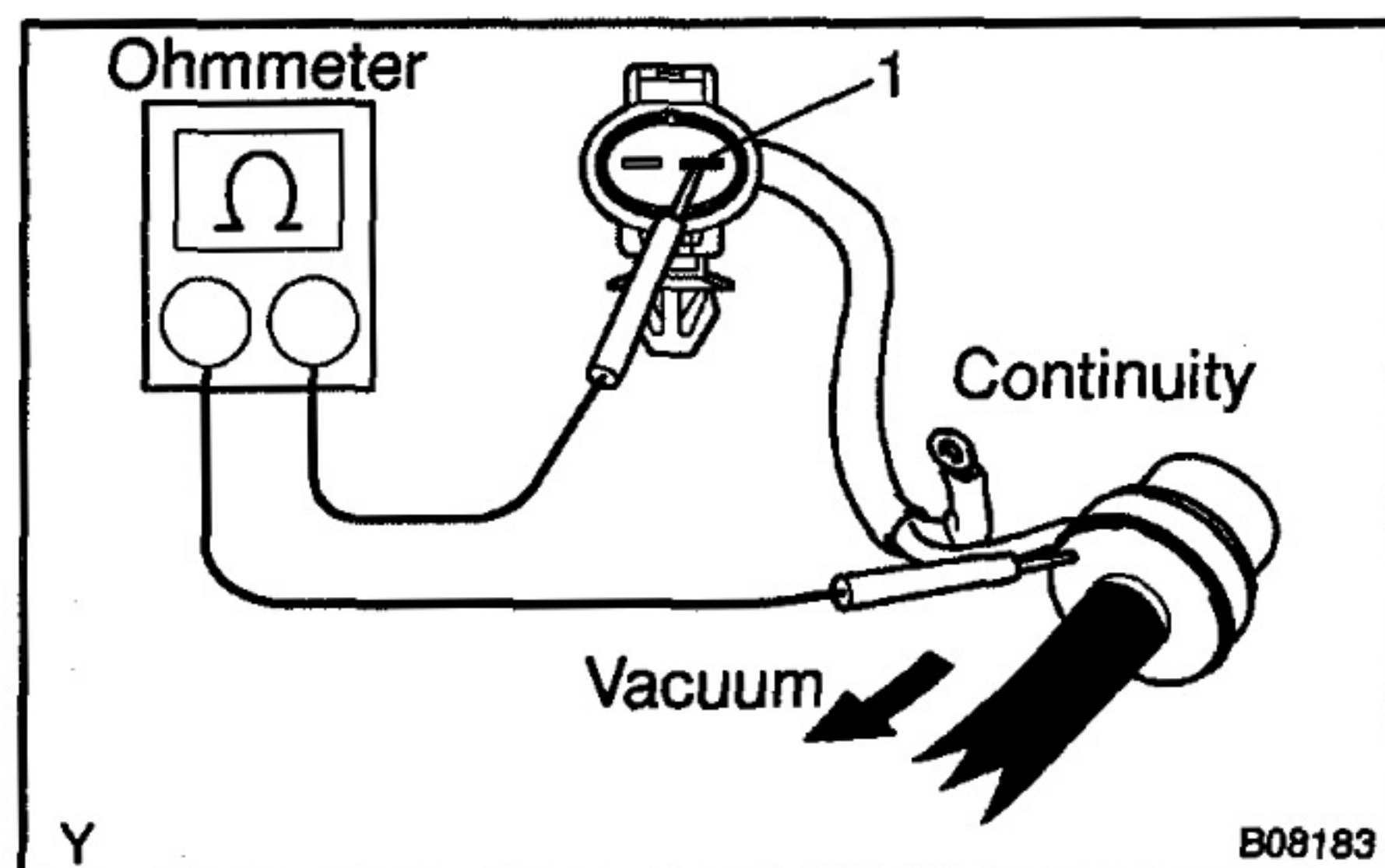

- (c) Inspect the vacuum switch operation.

- (1) Apply a vacuum of 34.7 ± 5.3 kPa (260 ± 40 mmHg, 10.24 ± 1.57 in.Hg) or more to the vacuum switch port.
- (2) Using an ohmmeter, check that there is continuity between terminal 1 and the switch body.

If operation is not as specified, replace the fuel heater.

3. REINSTALL FUEL HEATER

- (a) Install the fuel heater with the 2 screws.
Torque: $1.96 \text{ N}\cdot\text{m}$ ($20 \text{ kgf}\cdot\text{cm}$, $17 \text{ in}\cdot\text{lbf}$)
- (b) Connect the fuel heater connector.

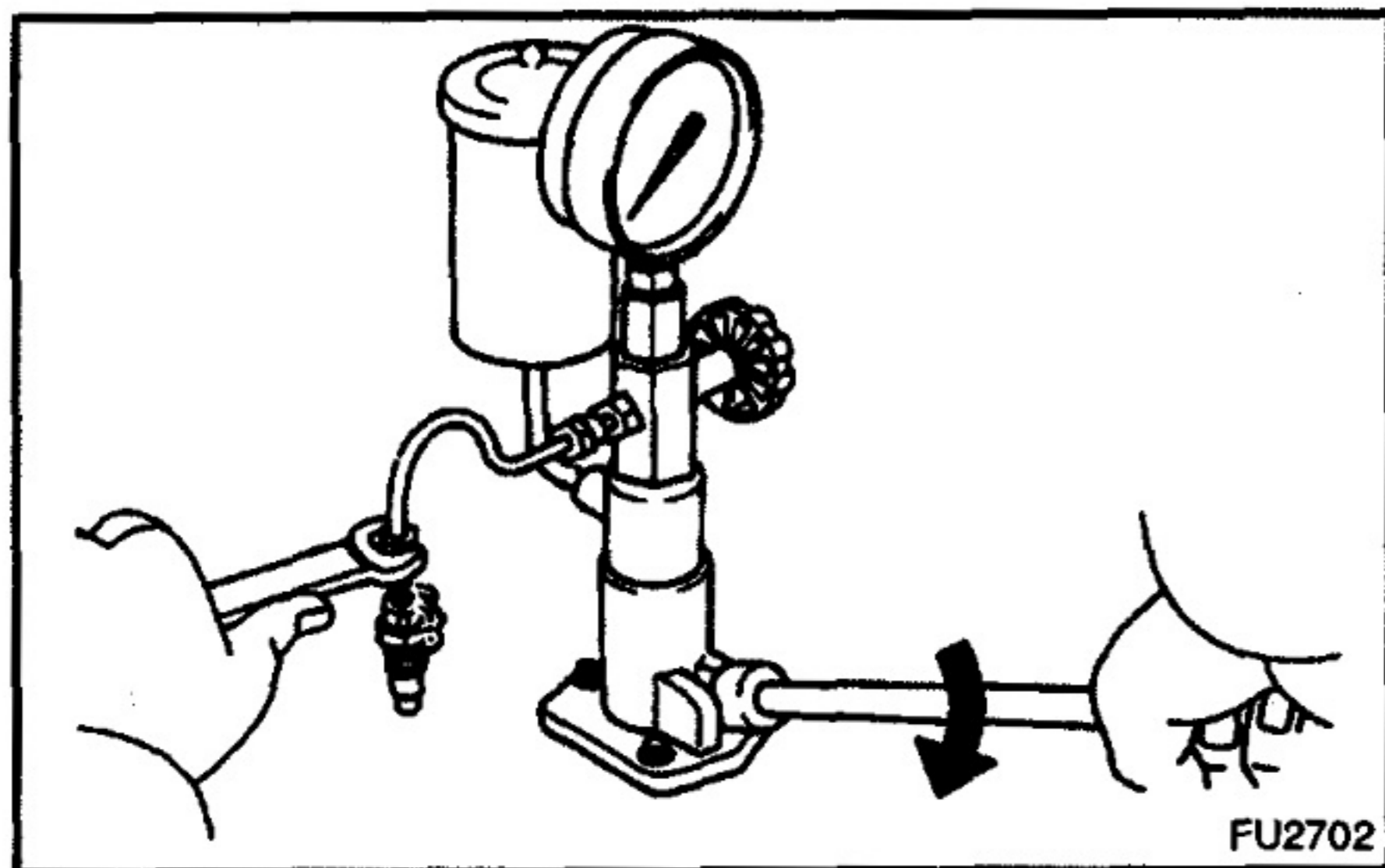

INJECTION NOZZLE TEST

FU06W-02

1. INJECTION PRESSURE TEST

- (a) Install the injection nozzle to the injection nozzle hand tester and bleed air from the union nut.

CAUTION:

Do not place your finger over the nozzle injection hole.

- (b) Pump the tester handle a few times as fast as possible to discharge the carbon from the injection hole.
- (c) Pump the tester handle slowly and observe the pressure gauge.

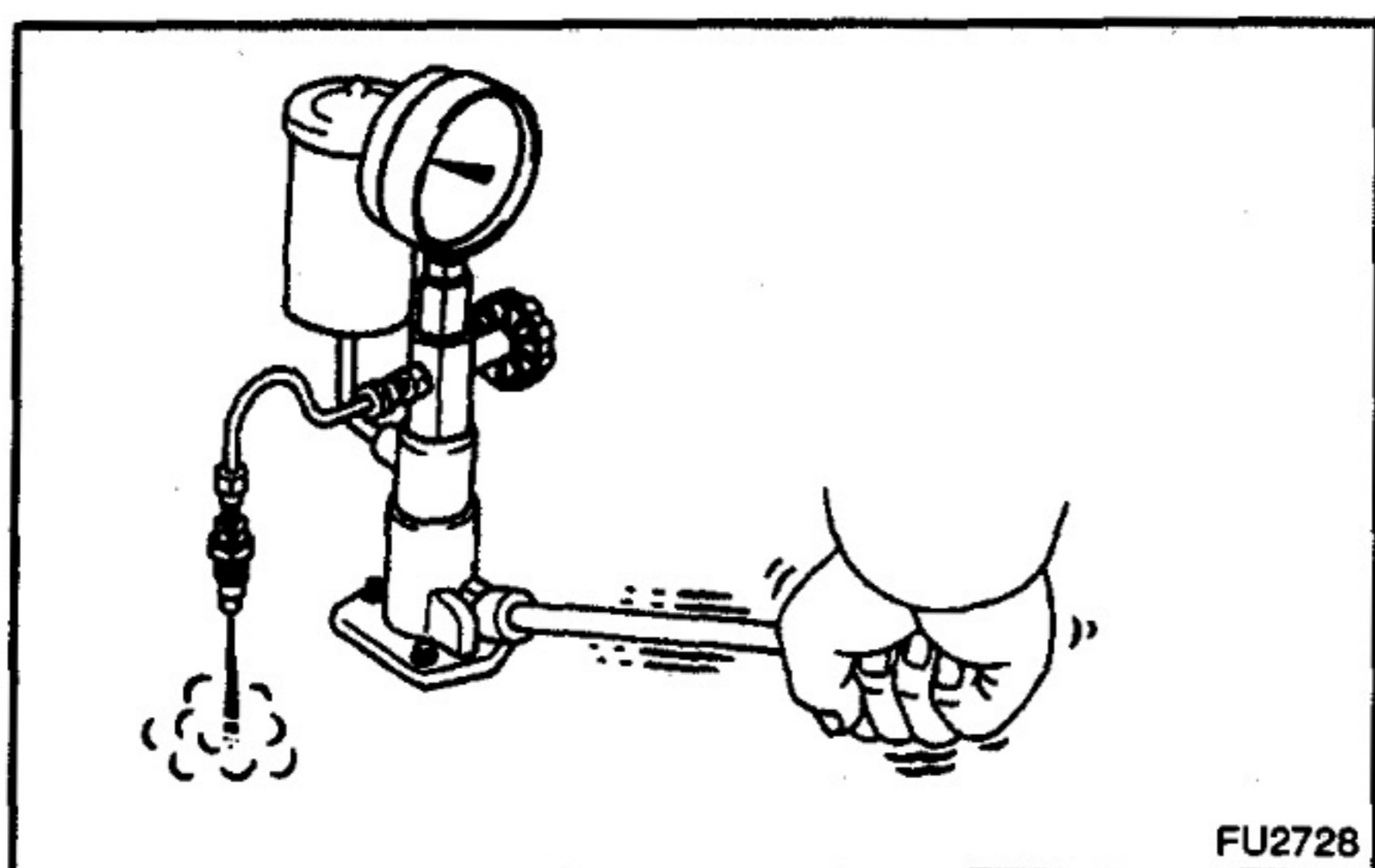

- (d) Read the pressure gauge just as the injection pressure begins to drop.

Opening pressure:

New nozzle	15,298 – 16,083 kPa (156 – 164 kgf/cm ² , 2,219 – 2,333 psi)
Reused nozzle	14,710 – 15,690 kPa (150 – 160 kgf/cm ² , 2,134 – 2,276 psi)

HINT:

Proper nozzle operation can be determined by a swishing sound.

If the opening pressure is not as specified, disassemble the nozzle holder and change the adjusting shim on the top of the pressure spring.

Adjusted opening pressure:

**14,710 – 15,690 kPa
(150 – 160 kgf/cm², 2,134 – 2,276 psi)**

Adjusting shim thickness:

mm (in.)	mm (in.)	mm (in.)
0.900 (0.0354)	1.275 (0.0502)	1.650 (0.0650)
0.925 (0.0364)	1.300 (0.0512)	1.675 (0.0659)
0.950 (0.0374)	1.325 (0.0522)	1.700 (0.0669)
0.975 (0.0384)	1.350 (0.0531)	1.725 (0.0679)
1.000 (0.0394)	1.375 (0.0541)	1.750 (0.0689)
1.025 (0.0404)	1.400 (0.0551)	1.775 (0.0699)
1.050 (0.0413)	1.425 (0.0561)	1.800 (0.0709)
1.075 (0.0423)	1.450 (0.0571)	1.825 (0.0719)
1.100 (0.0433)	1.475 (0.0581)	1.850 (0.0728)
1.125 (0.0443)	1.500 (0.0591)	1.875 (0.0738)
1.150 (0.0453)	1.525 (0.0600)	1.900 (0.0748)
1.175 (0.0463)	1.550 (0.0610)	1.925 (0.0758)
1.200 (0.0472)	1.575 (0.0620)	1.950 (0.0768)
1.225 (0.0482)	1.600 (0.0630)	-
1.250 (0.0492)	1.625 (0.0640)	-

HINT:

- Varying the adjusting shim thickness by 0.025 mm (0.0010 in.) changes the injection pressure by about 471 kPa (4.8 kgf/cm², 68 psi).
 - Only one adjusting shim should be used.
- (e) There should be no dripping after injection.

FU

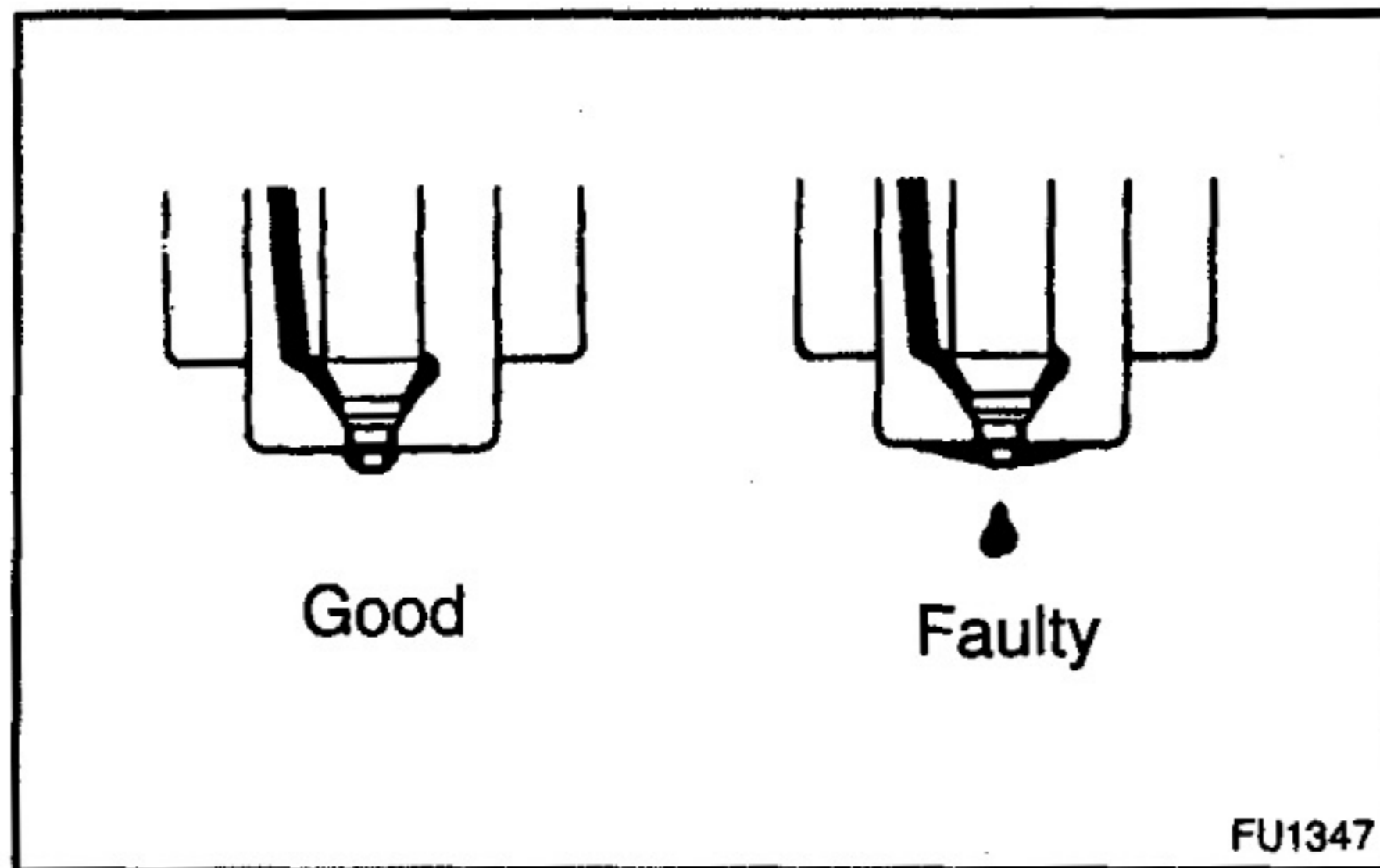

2. LEAKAGE TEST

While maintaining pressure at about 981 – 1,961 kPa (10 – 20 kgf/cm², 142 – 284 psi) below opening pressure (adjust by tester handle), check that there is no dripping for 10 seconds from the injection hole or around the retaining nut.

If the nozzle drips within 10 seconds, replace or clean and overhaul the nozzle assembly.

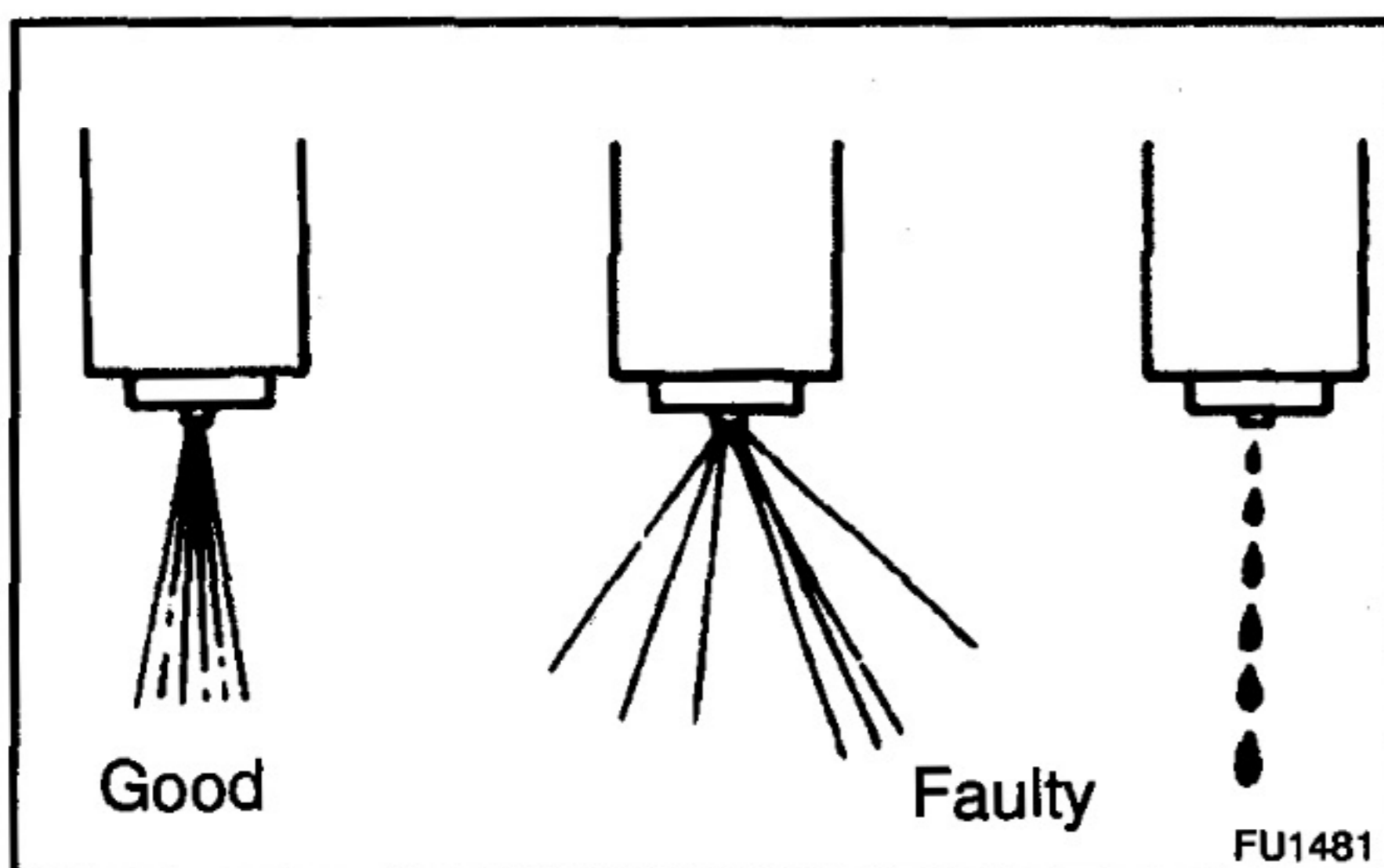

3. SPRAY PATTERN TEST

(a) The injection nozzle should shudder at a certain pumping speed between 15 – 60 times (old nozzle) or 30 – 60 times (new nozzle) per minute.

(b) Check the spray pattern during shuddering.

If the spray pattern is not correct during shuddering the nozzle must be replaced or cleaned.

INJECTION PUMP

FU06Y-02

ON-VEHICLE INSPECTION

1. INSPECT ENGINE SPEED SENSOR (See page ED-17)
2. INSPECT SPILL CONTROL VALVE (See page ED-9)
3. INSPECT INJECTION PUMP CORRECTION UNIT (See page DI-69)
4. INSPECT TIMING CONTROL VALVE (See page ED-8)

COMPONENTS

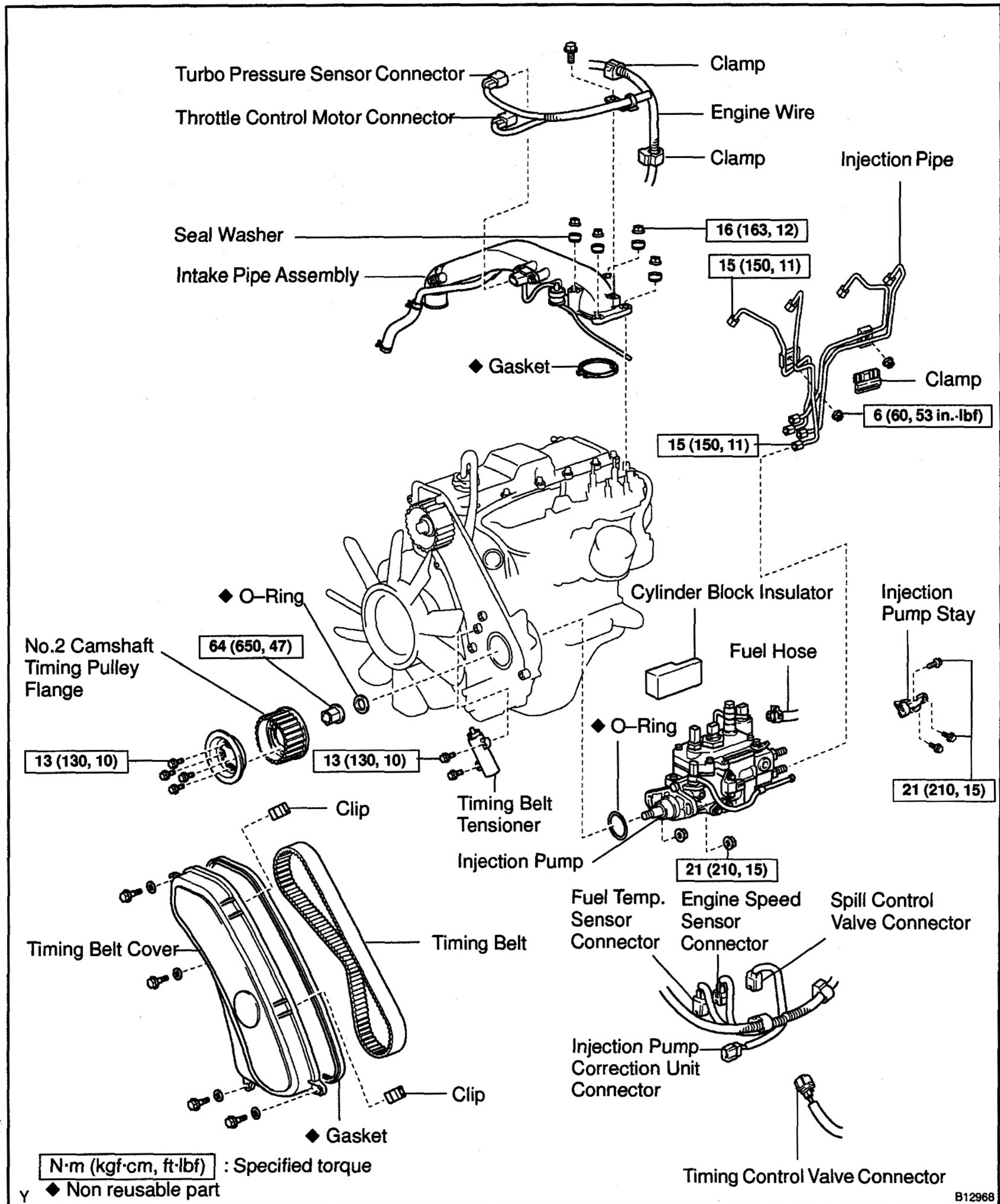

FU

ENGINE FUEL - INJECTION PUMP

Fuel Inlet Hollow
Screw

36.8 (375, 27)

24.5 (250, 18)
Cap Nut

◆ Gasket

Fuel Inlet Pipe

24.5 (250, 18)
Overflow Screw

◆ Gasket ◆ Gasket

24.5 (250, 18)

◆ Gasket

◆ O-Ring

Fuel Temp.
Sensor

Fuel Outlet Pipe

◆ O-Ring

◆ Gasket

Spill Control
Valve

Distributive Head Plug
88 (900, 65)

Engine Speed
Sensor

◆ Gasket

Spring

Delivery Valve

58.85 (600, 43)
Delivery Valve Holder

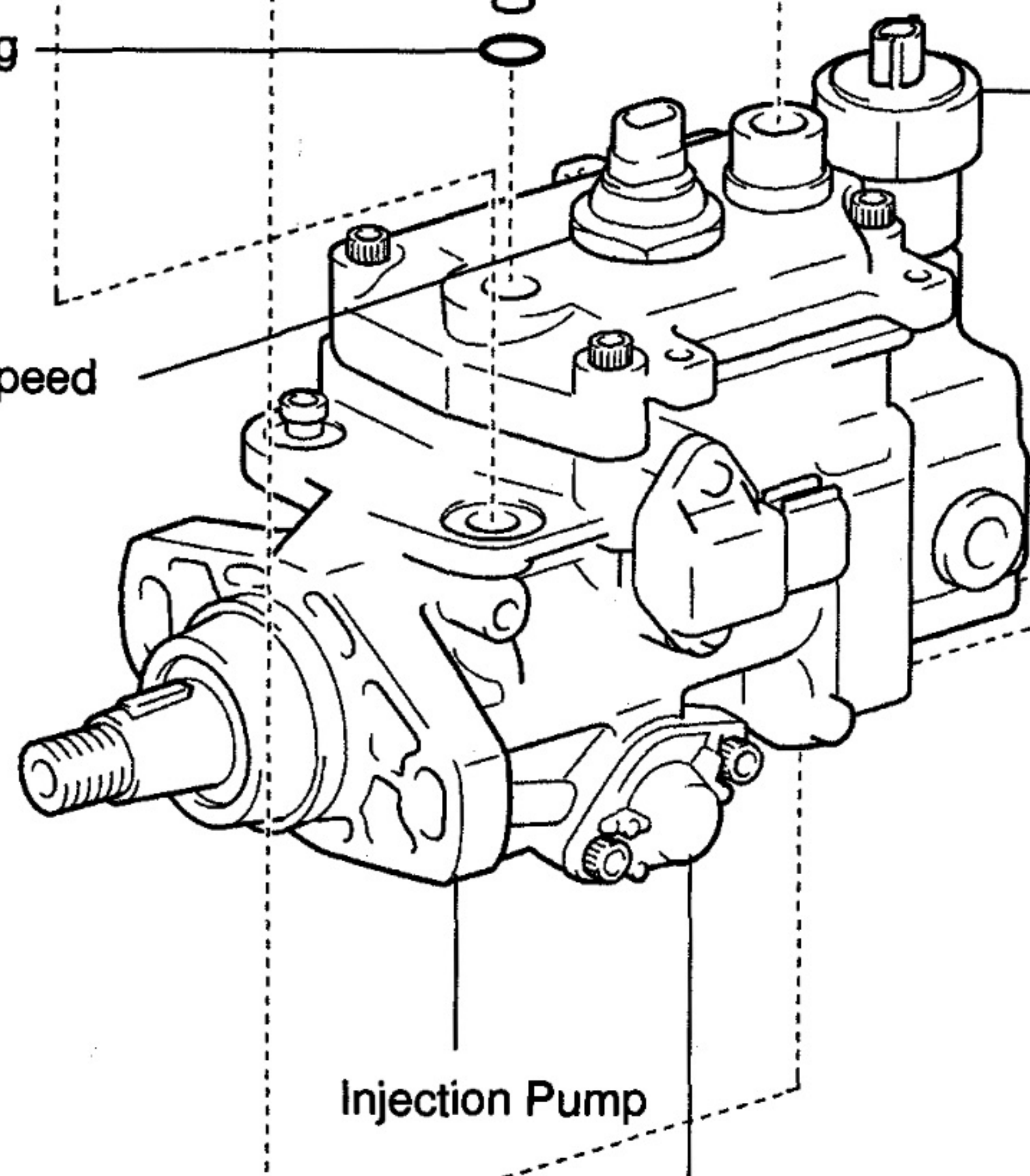

Injection Pump

Injection Pump
Correction Unit

◆ O-Ring

◆ O-Ring

Timing Control Valve

N·m (kgf·cm, ft·lbf) : Specified torque

◆ Non reusable part

FU

REMOVAL

1. **w/ Intercooler:**
REMOVE INTER COOLER (See page EM-2)
2. **w/o Intercooler:**
REMOVE INTAKE PIPE (See page EM-2)
3. **REMOVE INJECTION PIPES (See Pub. No. RM710E, page FU-5)**
4. **REMOVE TIMING BELT (See Pub. No. RM710E, page EM-13)**

5. CHECK INJECTION PUMP DRIVE SHAFT THRUST CLEARANCE

- (a) Turn the crankshaft pulley counterclockwise, so the pulley groove is about 30° from the timing pointer.

HINT:

To do this in order to adjust the teeth of the scissors portion of the idler gear.

- (b) Move the No. 2 camshaft timing pulley forward and backward and understand the sense of thrust clearance of the injection pump.

6. REMOVE NO. 2 CAMSHAFT TIMING PULLEY (See Pub. No. RM710E, page EM-13)

7. REMOVE INJECTION PUMP

- (a) Disconnect the engine speed sensor connector.
- (b) Disconnect the spill control valve connector.
- (c) Disconnect the injection pump correction unit connector.
- (d) Disconnect the timing control valve connector.
- (e) Disconnect the fuel temperature sensor connector.
- (f) Disconnect the engine wire clamp and fuel hose.

- (g) Hold the crankshaft pulley bolt, and remove the injection pump drive gear set nut.
- (h) Remove the O-ring from the injection pump drive gear.

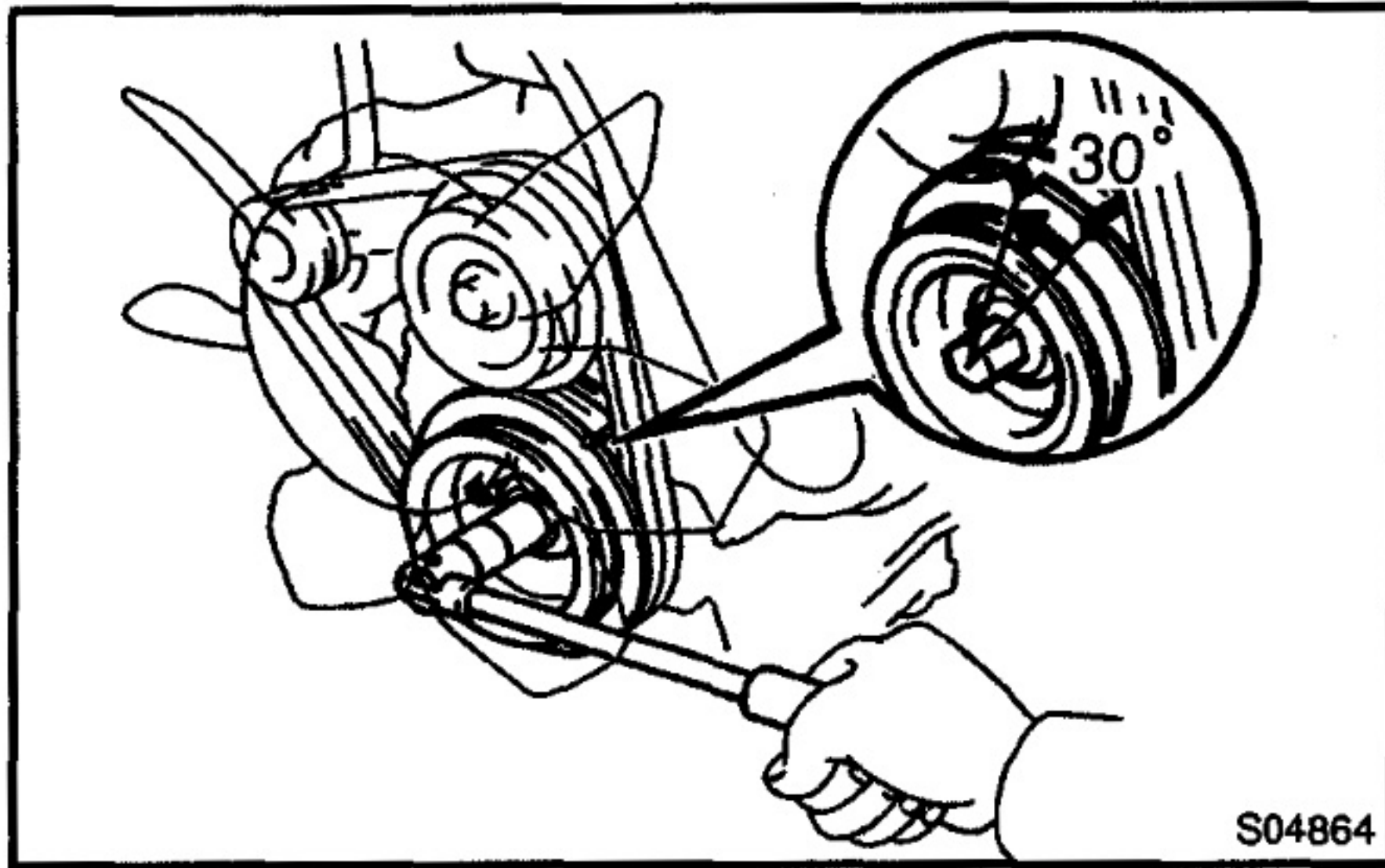

FU

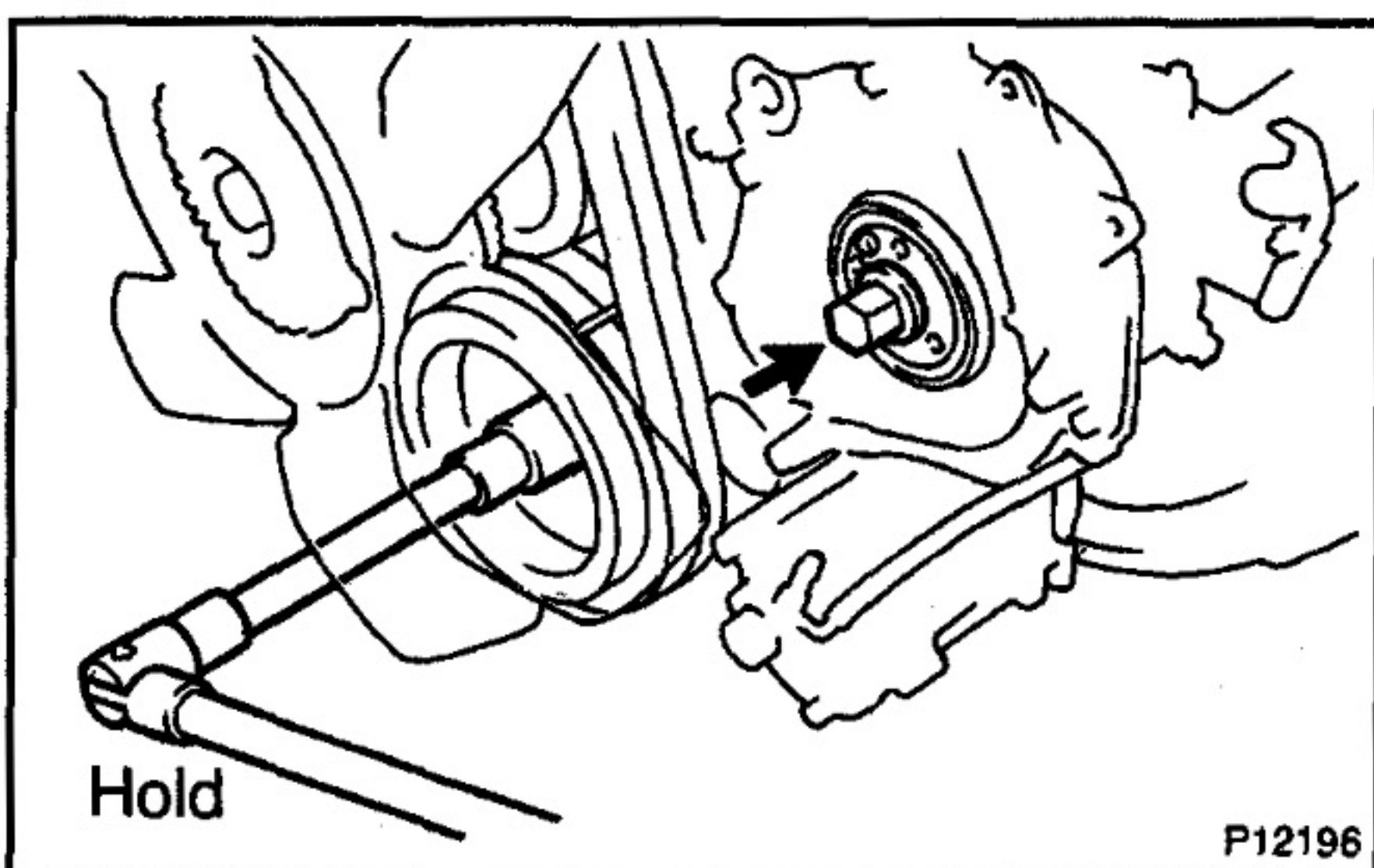
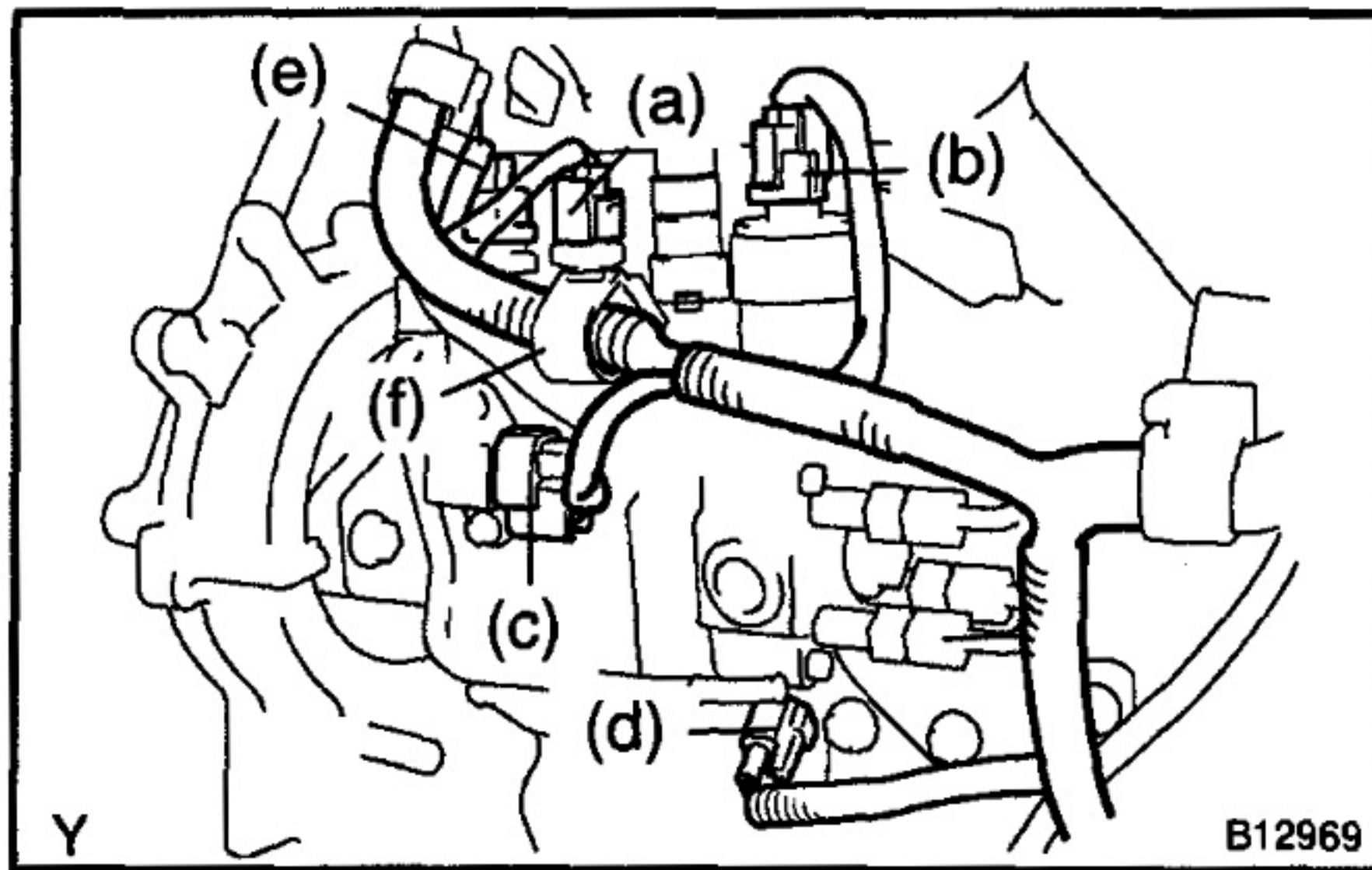

ENGINE FUEL - INJECTION PUMP

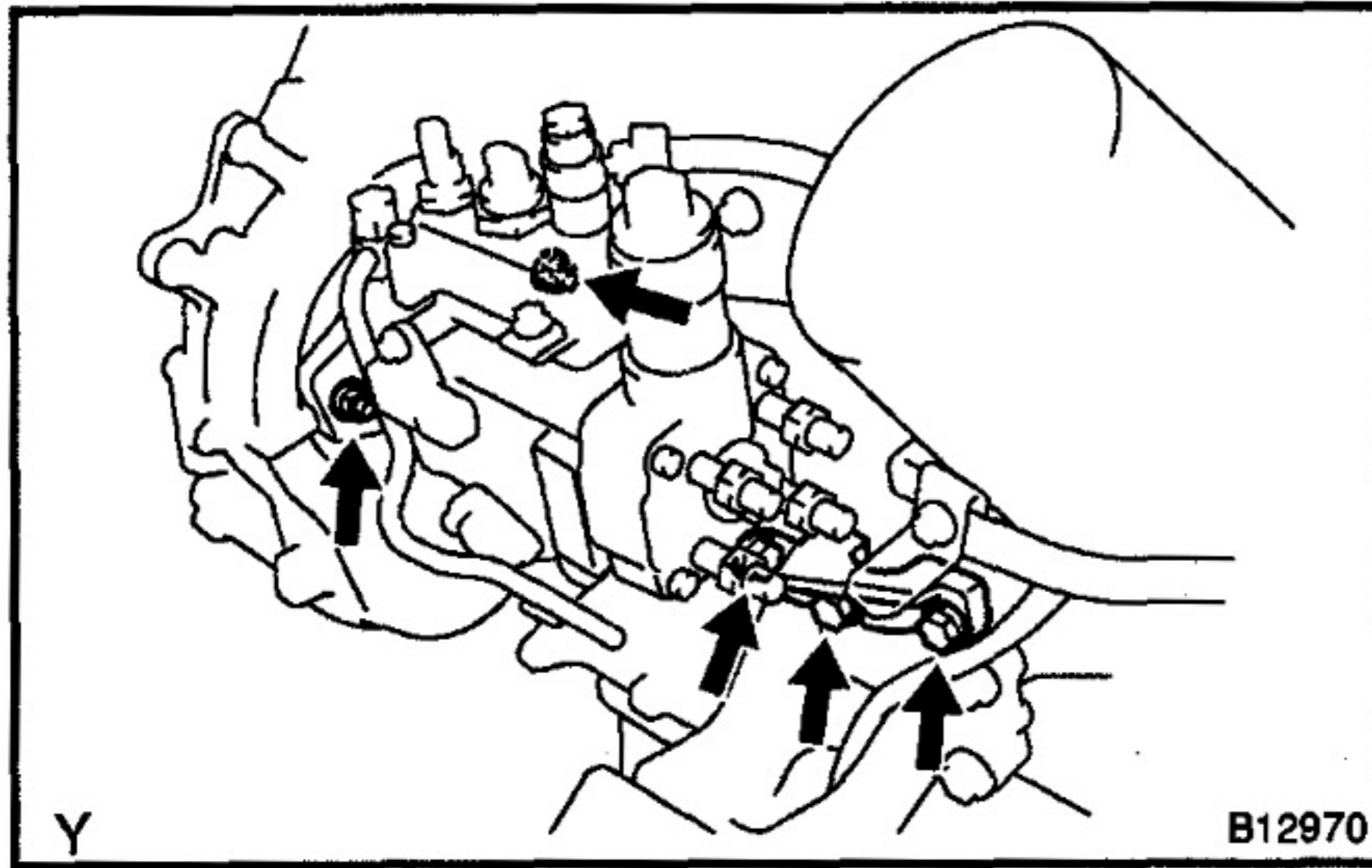

- (i) Loosen the 2 nuts holding the injection pump to the timing gear case.
- (j) Remove the 3 bolts and injection pump stay.

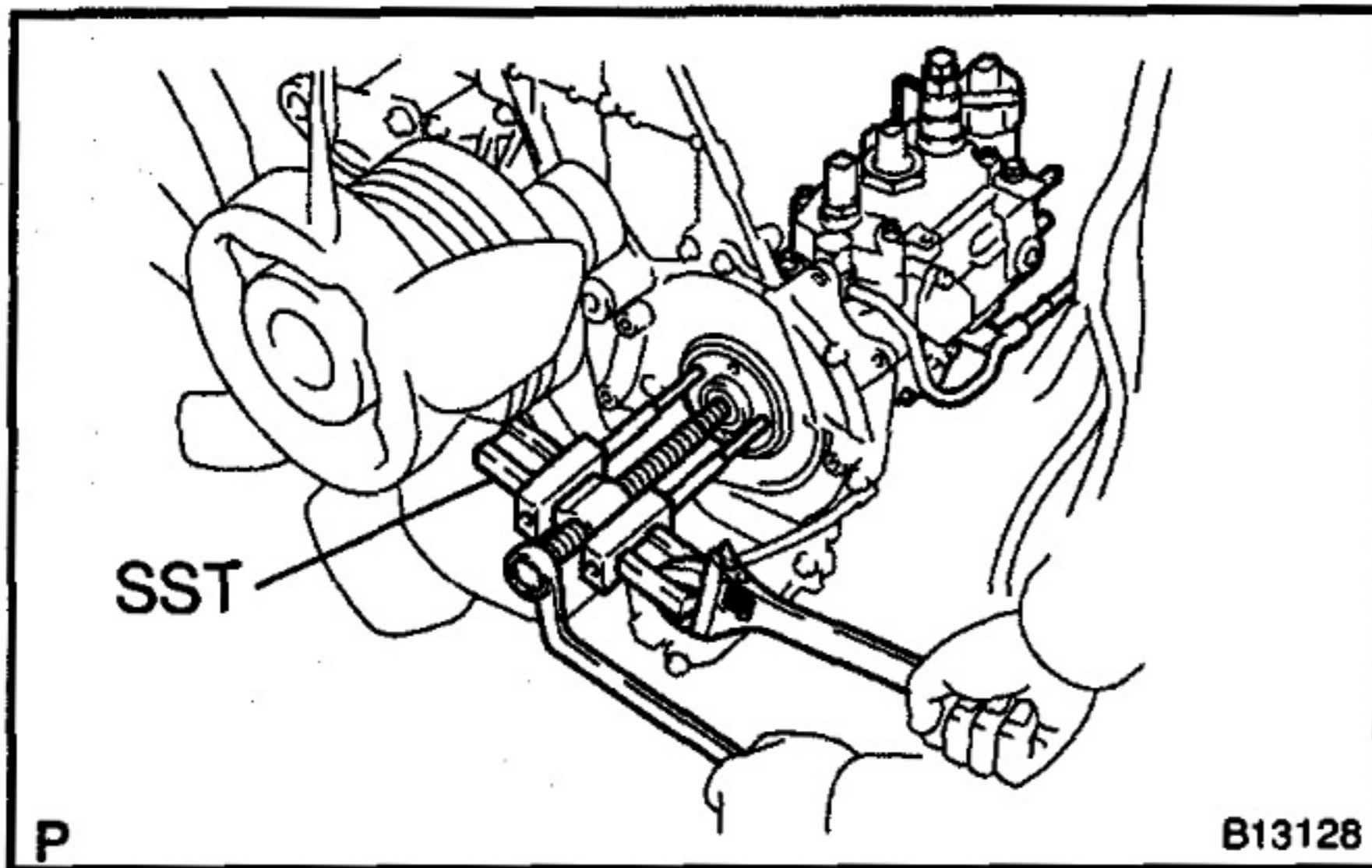

- (k) Using SST, disconnect the injection pump from the timing gear case.
SST 09960-50010 (09951-05010, 09952-05010, 09953-05020, 09954-05010)
- (l) Remove the 2 nuts, injection pump and cylinder block insulator.
- (m) Remove the O-ring from the injection pump.

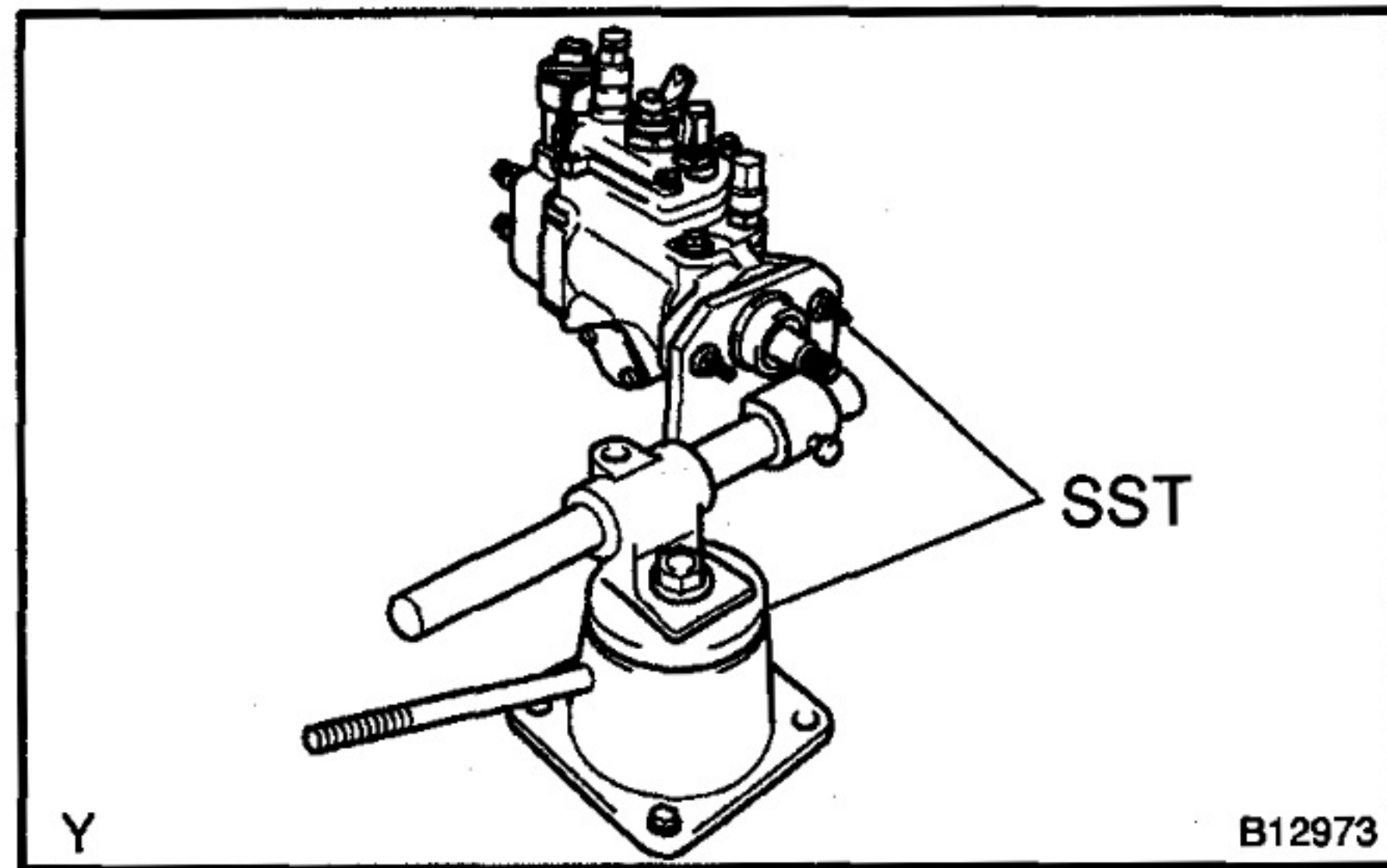

DISASSEMBLY

- 1. MOUNT PUMP ASSEMBLY TO SST (STAND)**
SST 09241-76022, 09245-54010
- 2. REMOVE SET KEY OF DRIVE PULLEY FROM DRIVE SHAFT**

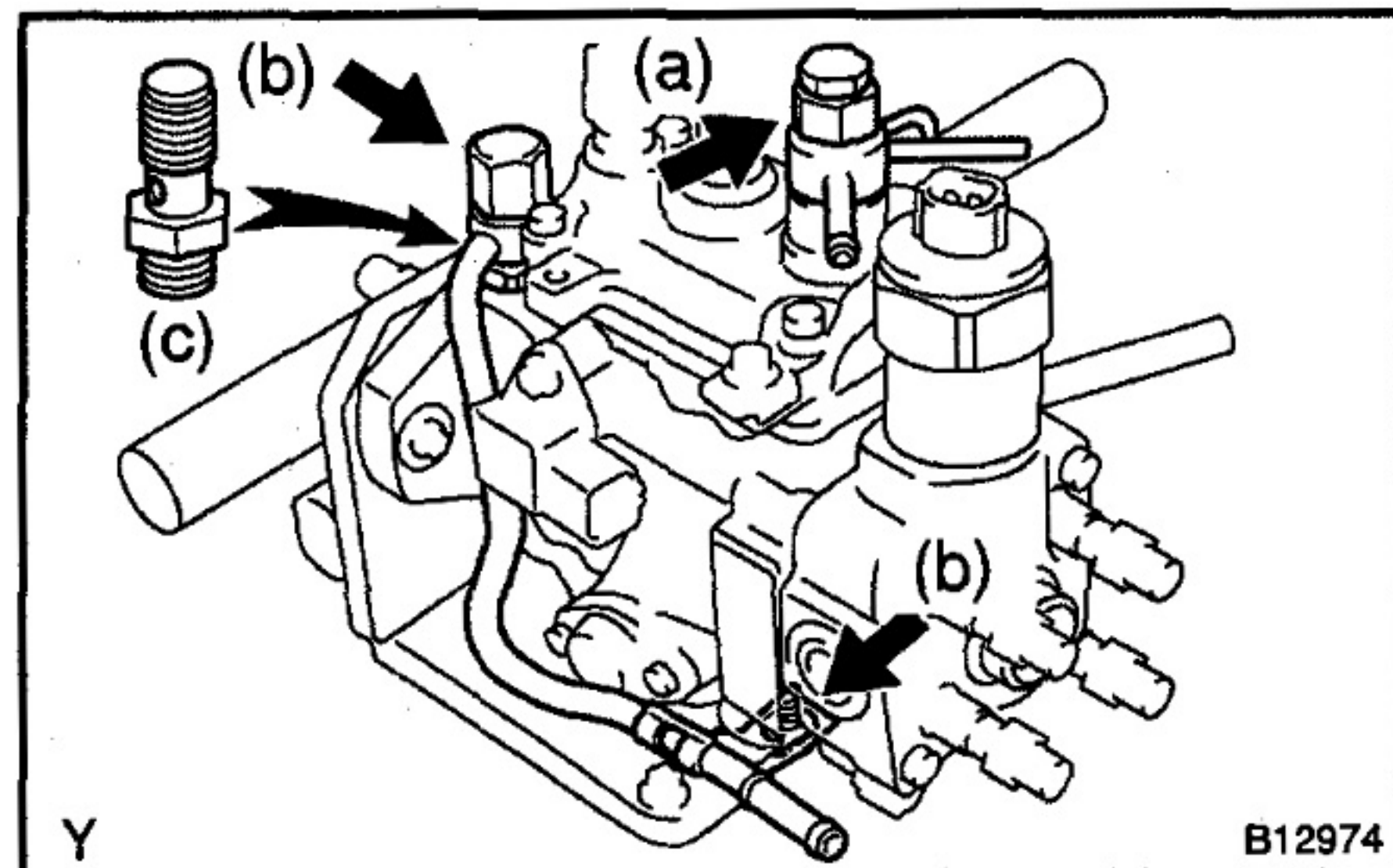

- 3. REMOVE FUEL PIPES AND INLET HOLLOW SCREW**
 - Remove the overflow screw, fuel outlet pipe and 2 gaskets.
 - Remove the cap nut, bolt, fuel inlet pipe and 2 gaskets.
 - Remove the fuel inlet hollow screw and gasket.

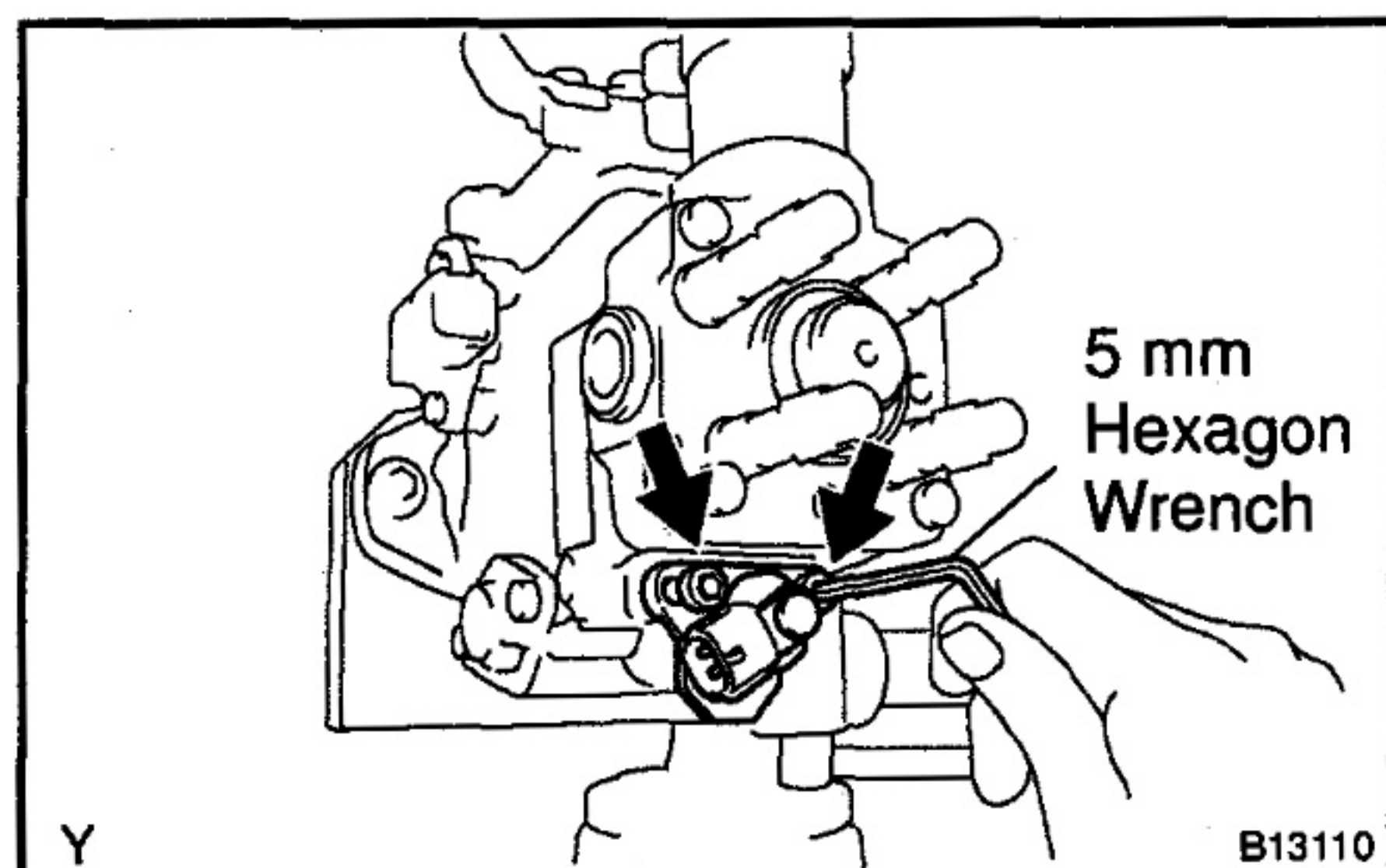

- 4. REMOVE TIMING CONTROL VALVE**
Using a 5 mm hexagon wrench, remove the 2 bolts and timing control valve.

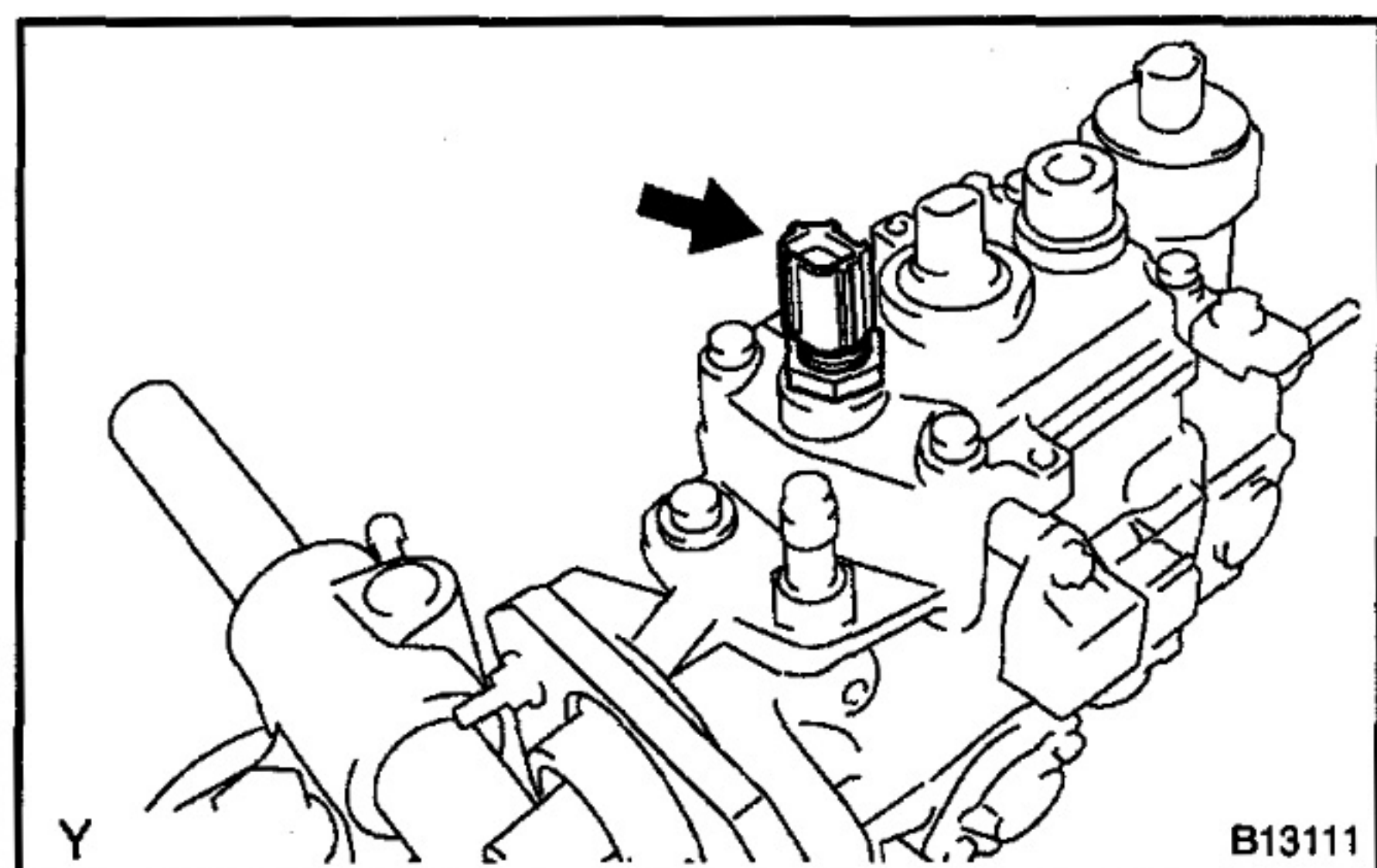

- 5. REMOVE FUEL TEMPERATURE SENSOR**
Using a 19 mm deep socket wrench, remove the fuel temperature sensor and O-ring.

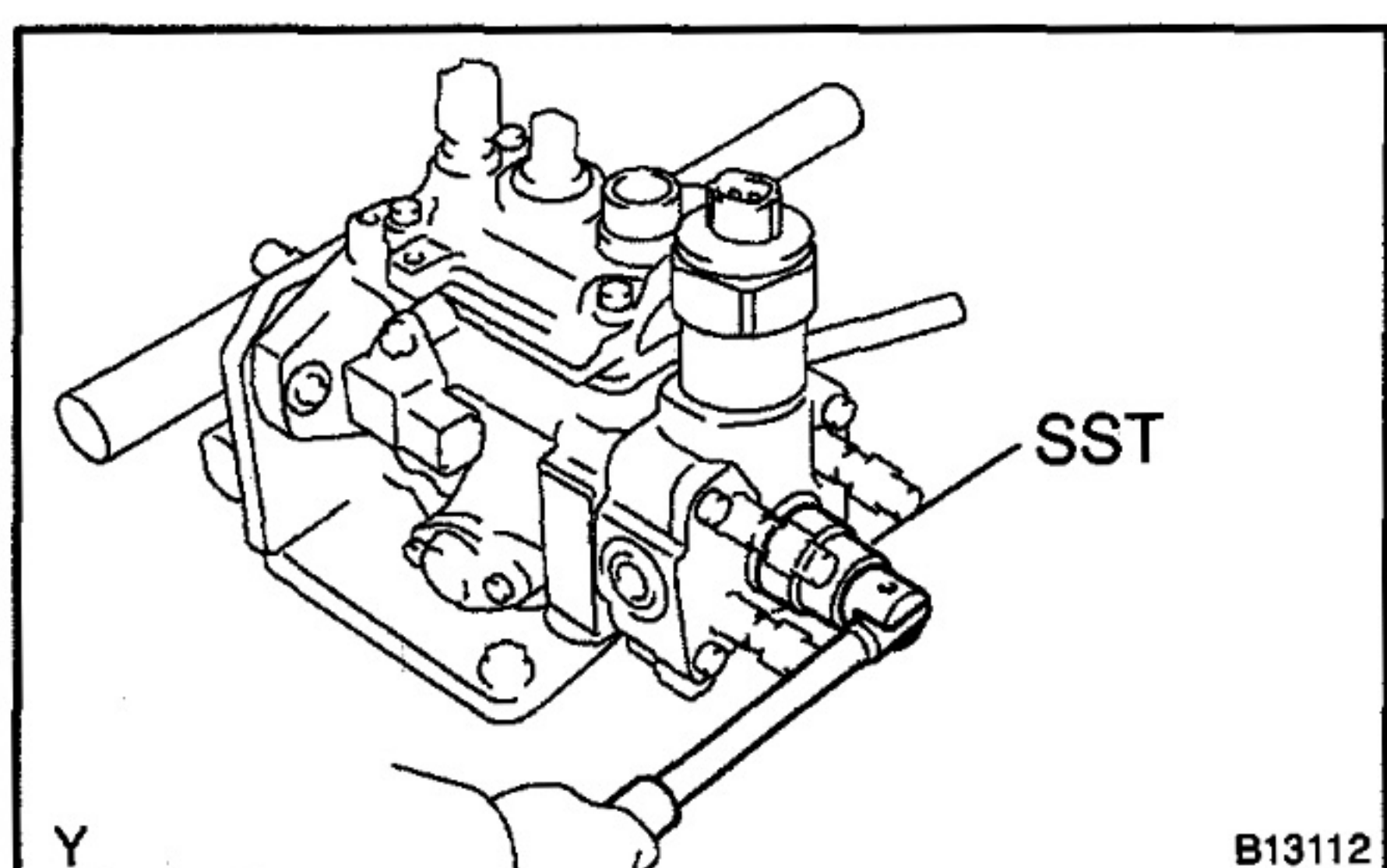

- 6. REMOVE DISTRIBUTIVE HEAD PLUG**
Using SST, remove the distributive head plug.
SST 09260-54012 (09262-54010)

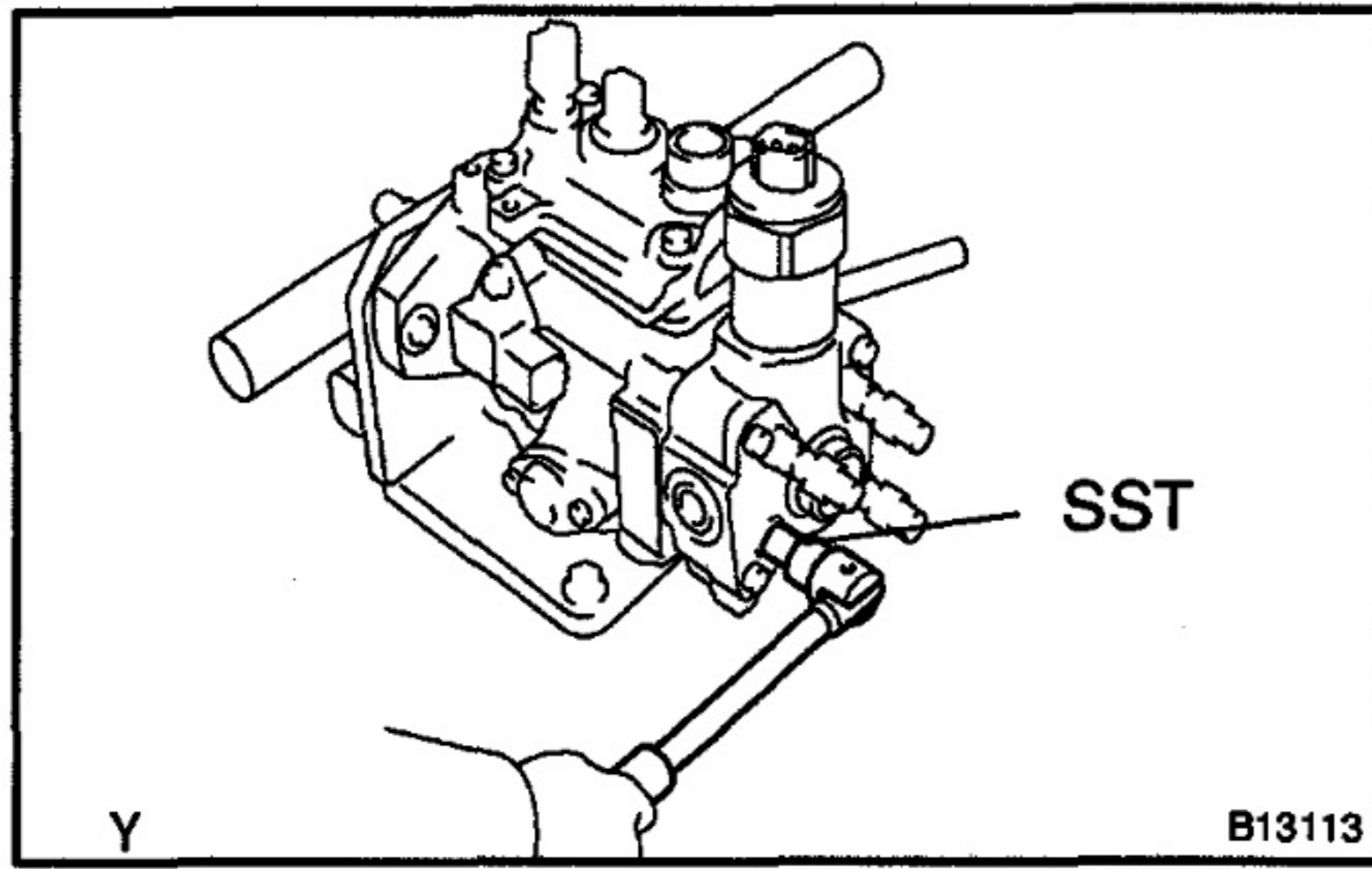
**7. REMOVE DELIVERY VALVE HOLDERS**

- (a) Using SST, remove the 4 delivery valve holders and springs.

SST 09260-54012 (09269-54020)

- (b) Remove the 4 delivery valves and gaskets.

NOTICE:

Do not touch the sliding surfaces of the delivery valve with your hand.

HINT:

Arrange the delivery valves, springs, and holders in order.

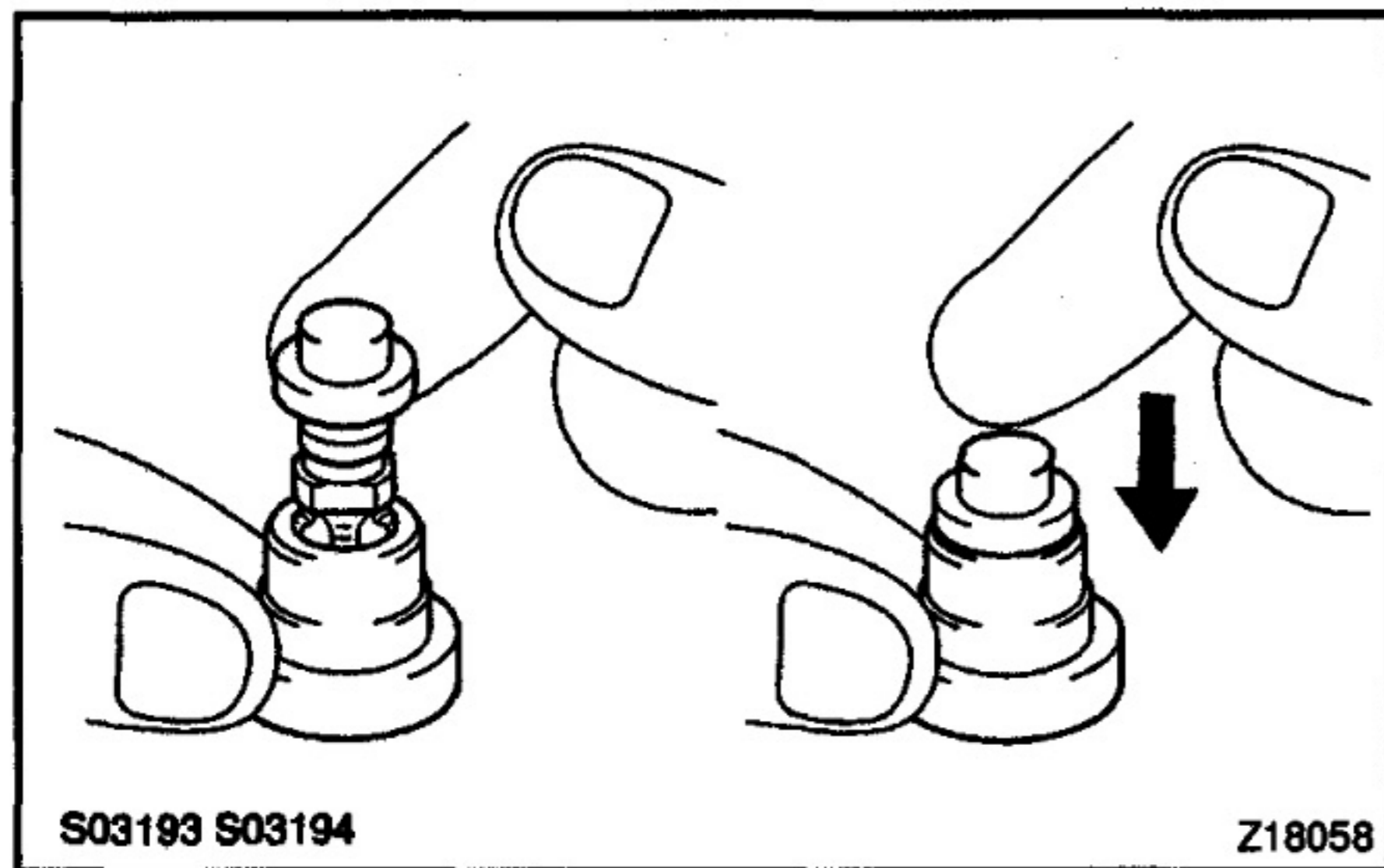

INSPECTION

NOTICE:

Do not touch the sliding surfaces of the delivery valves.

INSPECT DELIVERY VALVES

Pull up the valve, release it.

Check that it sinks smoothly to the valve seat.

If operation is not as specified, replace the valve as a set.

HINT:

Before using a new valve set, wash off the rust prevention compound with diesel fuel. Then re-wash with diesel fuel and perform the above tests.

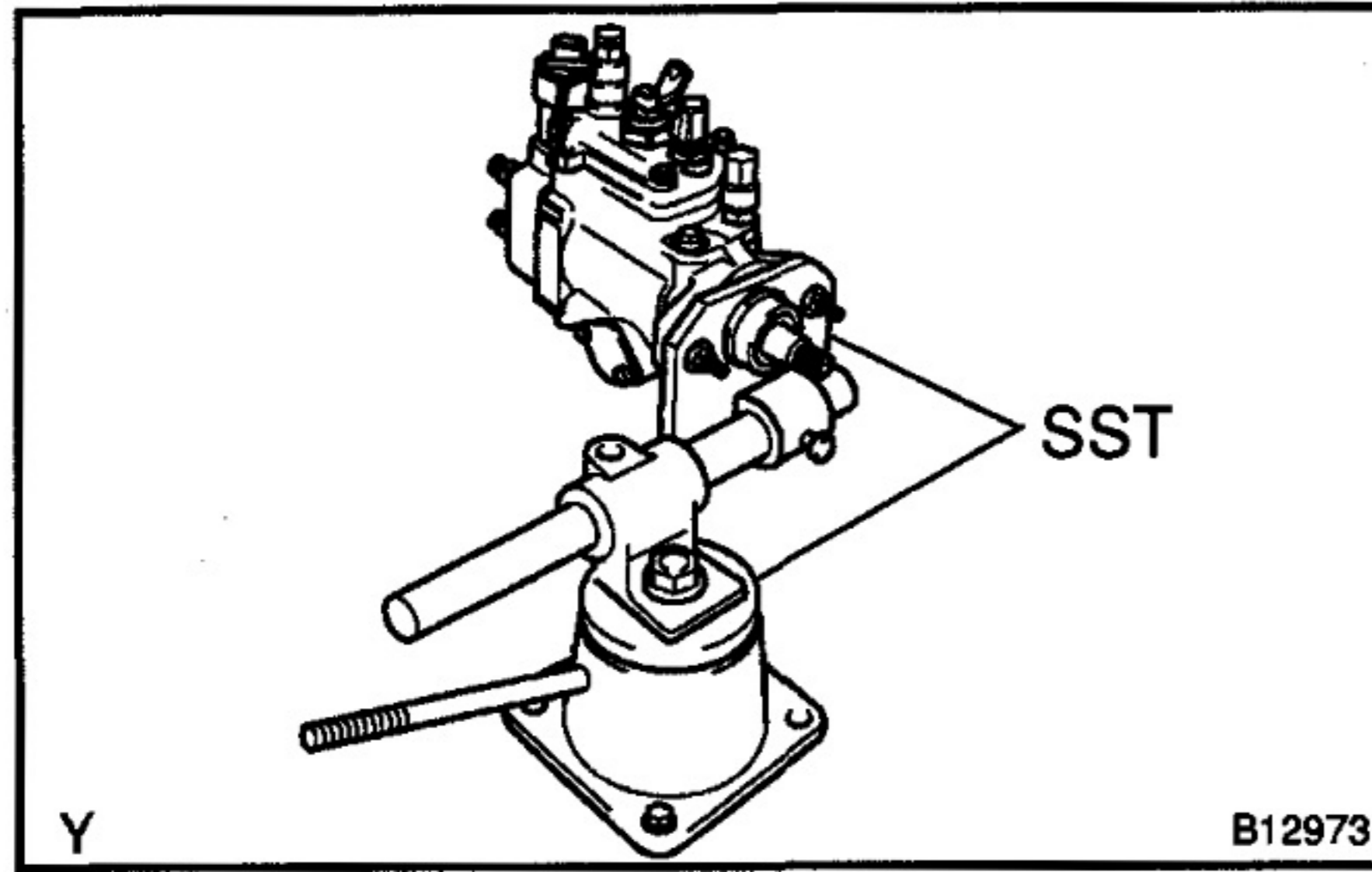

REASSEMBLY

1. MOUNT PUMP BODY TO SST (STAND)

SST 09241-76022, 09245-54010

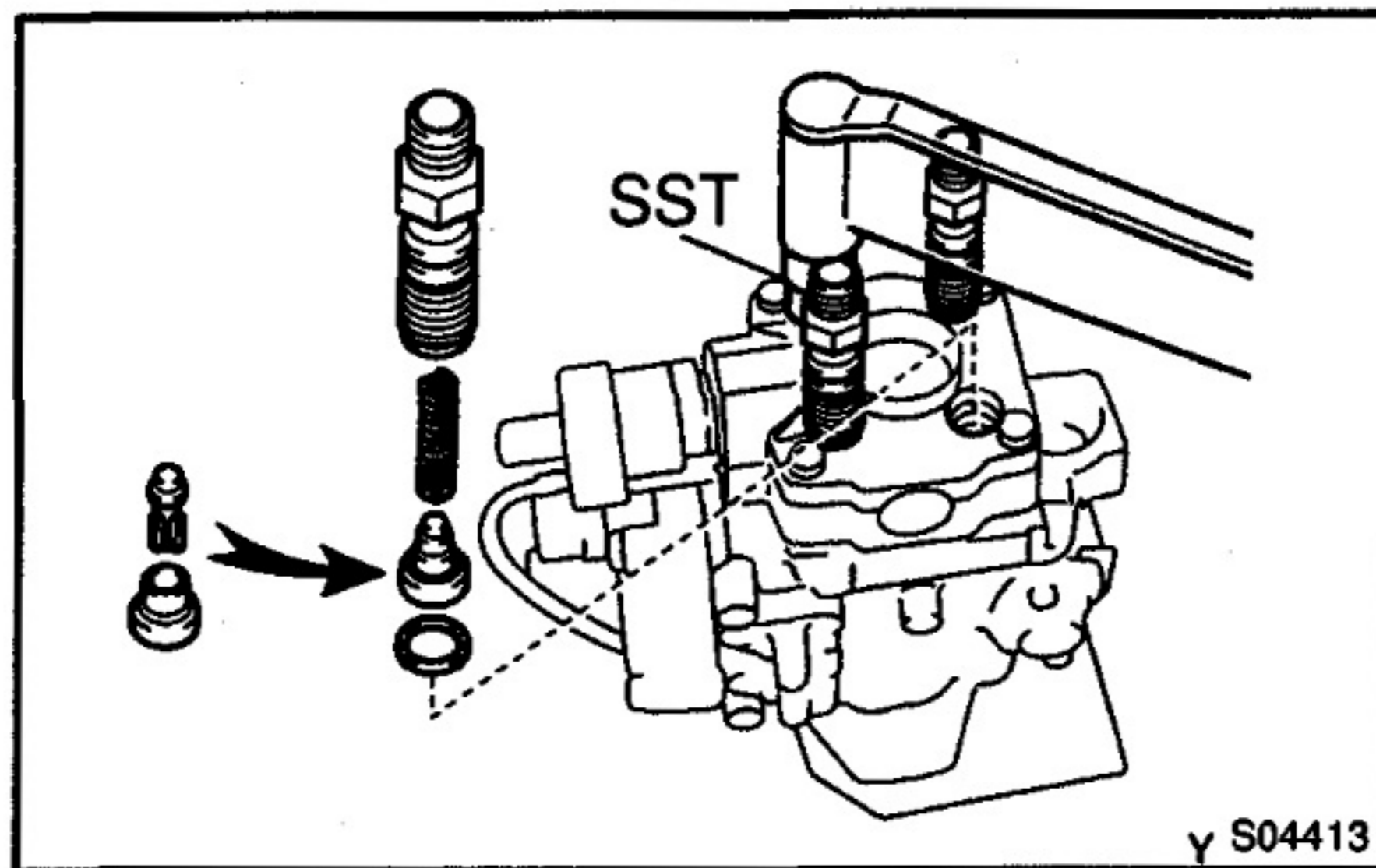

2. INSTALL DELIVERY VALVE HOLDERS

- (a) Install new gaskets and the valves into the distributive head.
- (b) Install the springs into the delivery valve holders.
- (c) Using SST, install the delivery valve holders.

SST 09260-54012 (09269-54020)

Torque: 58.85 N-m (600 kgf-cm, 43 ft-lbf)

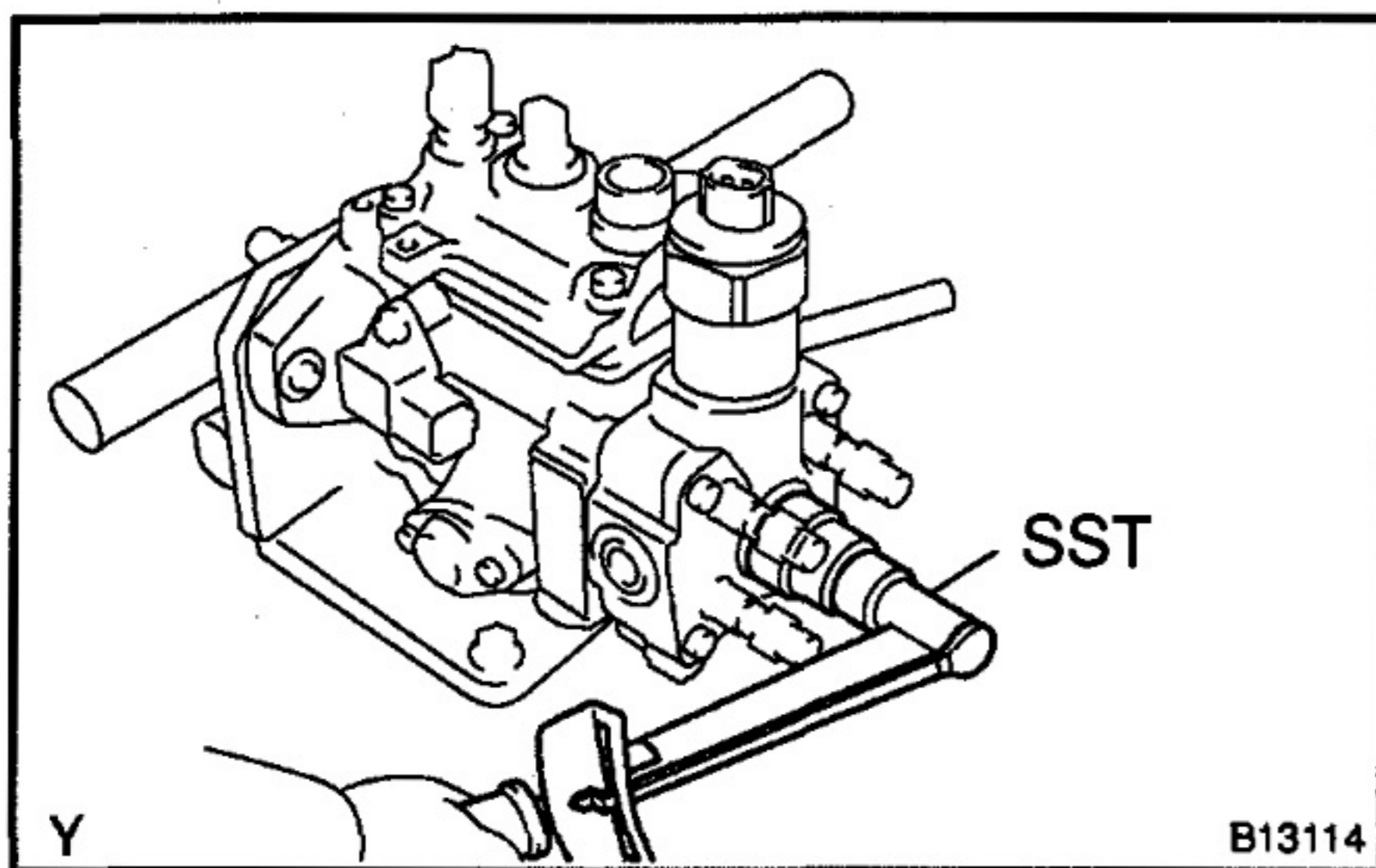

3. INSTALL DISTRIBUTIVE HEAD PLUG

- (a) Install a new O-ring to the distributive head plug.
- (b) Using SST, install the head plug.

SST 09260-54012 (09262-54010)

Torque: 88 N-m (900 kgf-cm, 65 ft-lbf)

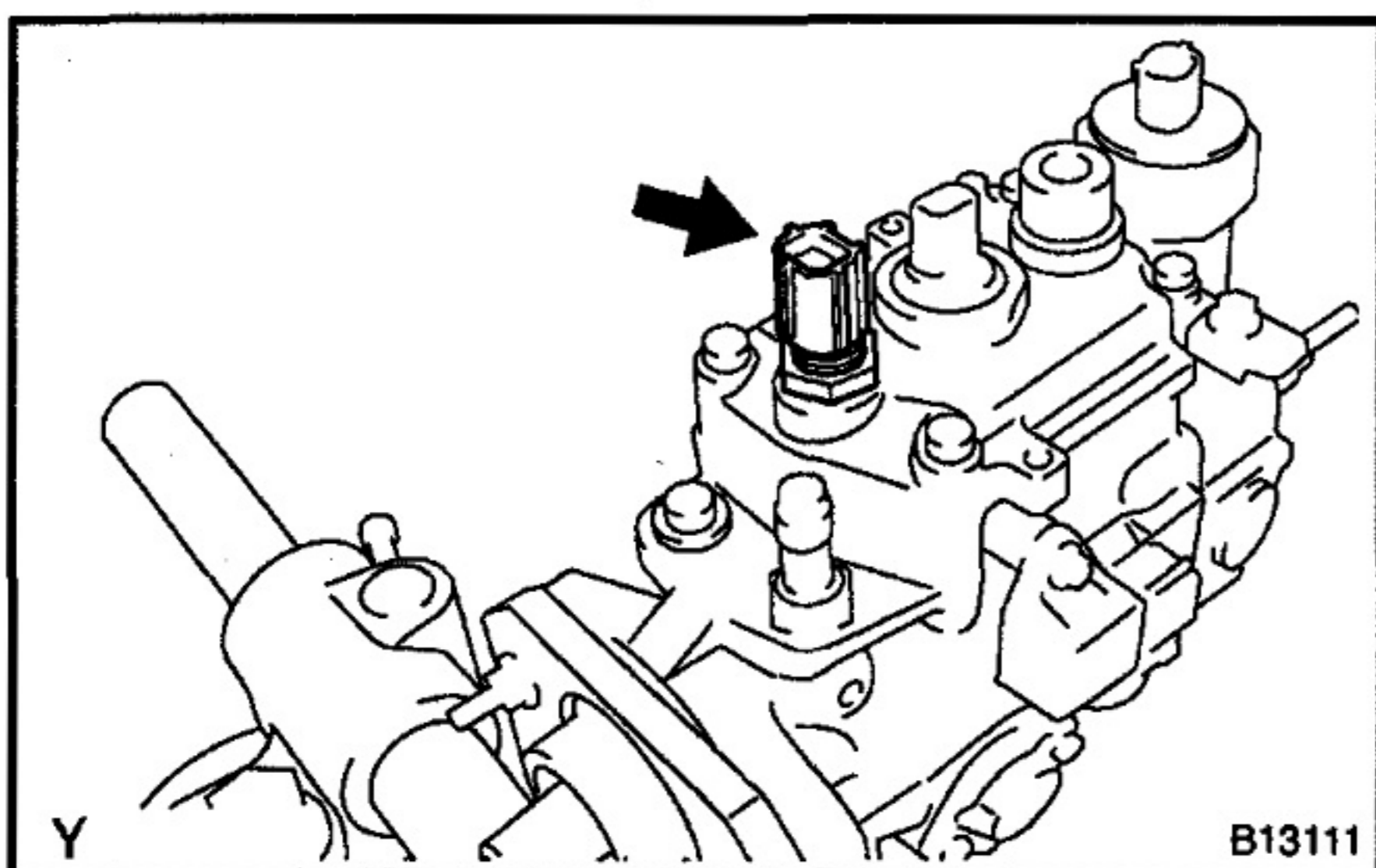

4. INSTALL FUEL TEMPERATURE SENSOR

- (a) Install a new O-ring to the fuel temperature sensor.
- (b) Using a 19 mm deep socket wrench, install the fuel temperature sensor.

Torque: 21.6 N-m (220 kgf-cm, 16 ft-lbf)

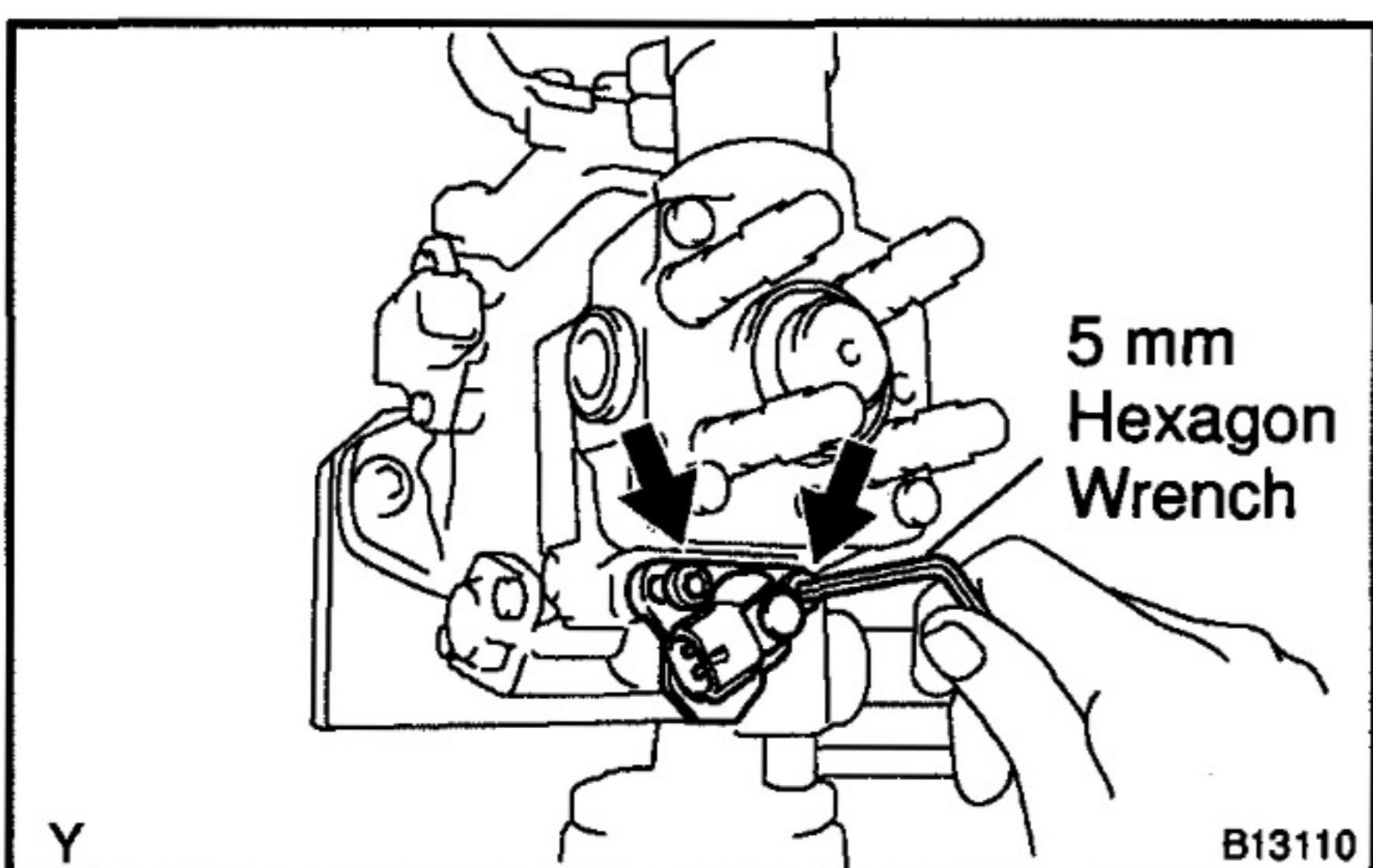

5. INSTALL TIMING CONTROL VALVE

Using a 5 mm hexagon wrench, install the timing control valve with the 2 bolts.

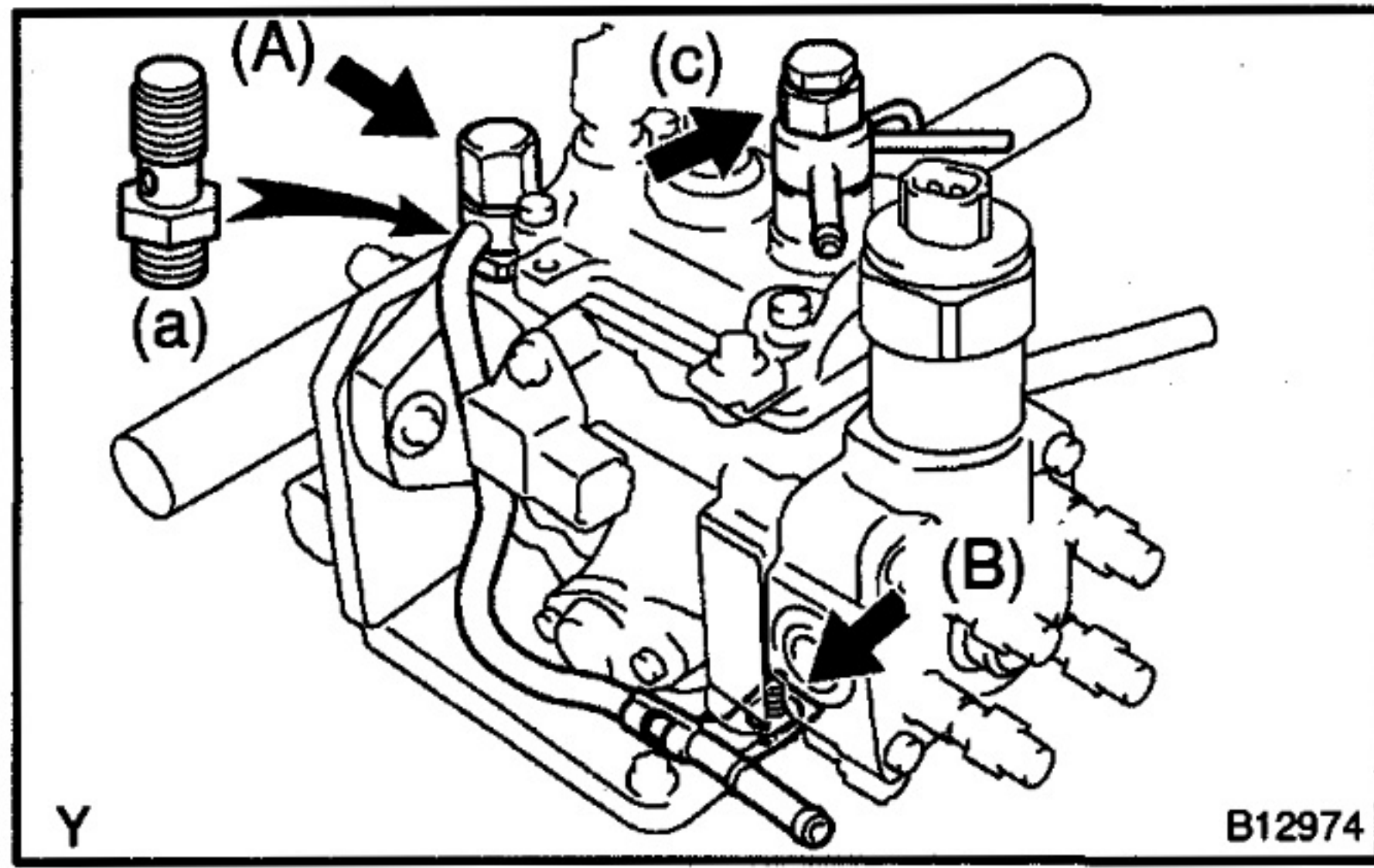

6. INSTALL FUEL INLET HOLLOW SCREWS FUEL PIPES

- (a) Install a new gasket and the hollow screw.
Torque: 36.8 N·m (375 kgf·cm, 27 ft·lbf)
- (b) Install the fuel inlet pipe with 2 new gaskets, the cap nut (A) and bolt (B).
Torque:

24.5 N·m (250 kgf·cm, 18 ft·lbf) for (A) and (B)

- (c) Install fuel outlet pipe with a new gasket and the overflow screw.

Torque: 24.5 N·m (250 kgf·cm, 18 ft·lbf)

7. REMOVE INJECTION PUMP FROM SST (STAND)

SST 09241-76022, 09245-54010

8. INSTALL SET KEY OF INJECTION PUMP DRIVE PULLEY ON DRIVE SHAFT

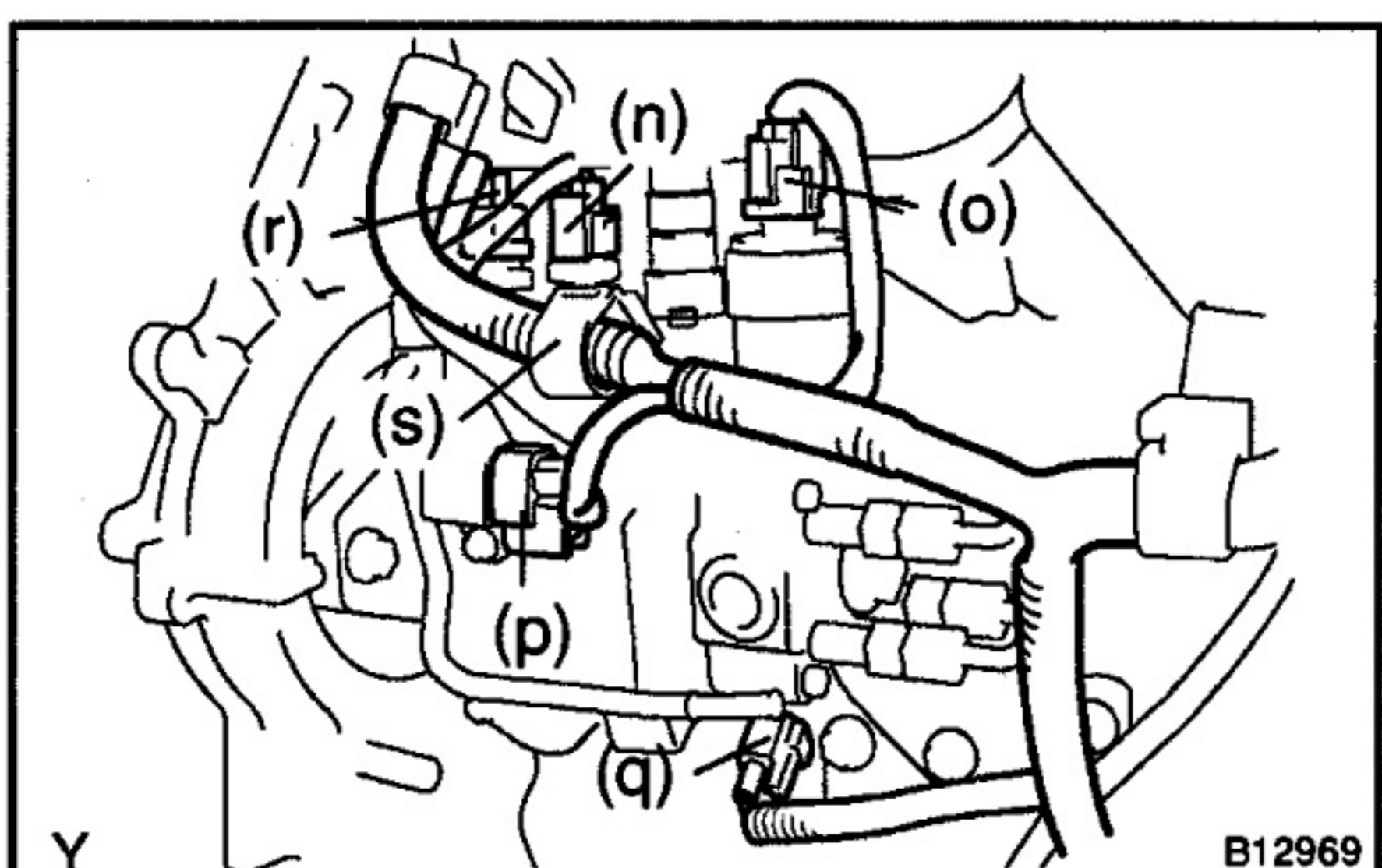
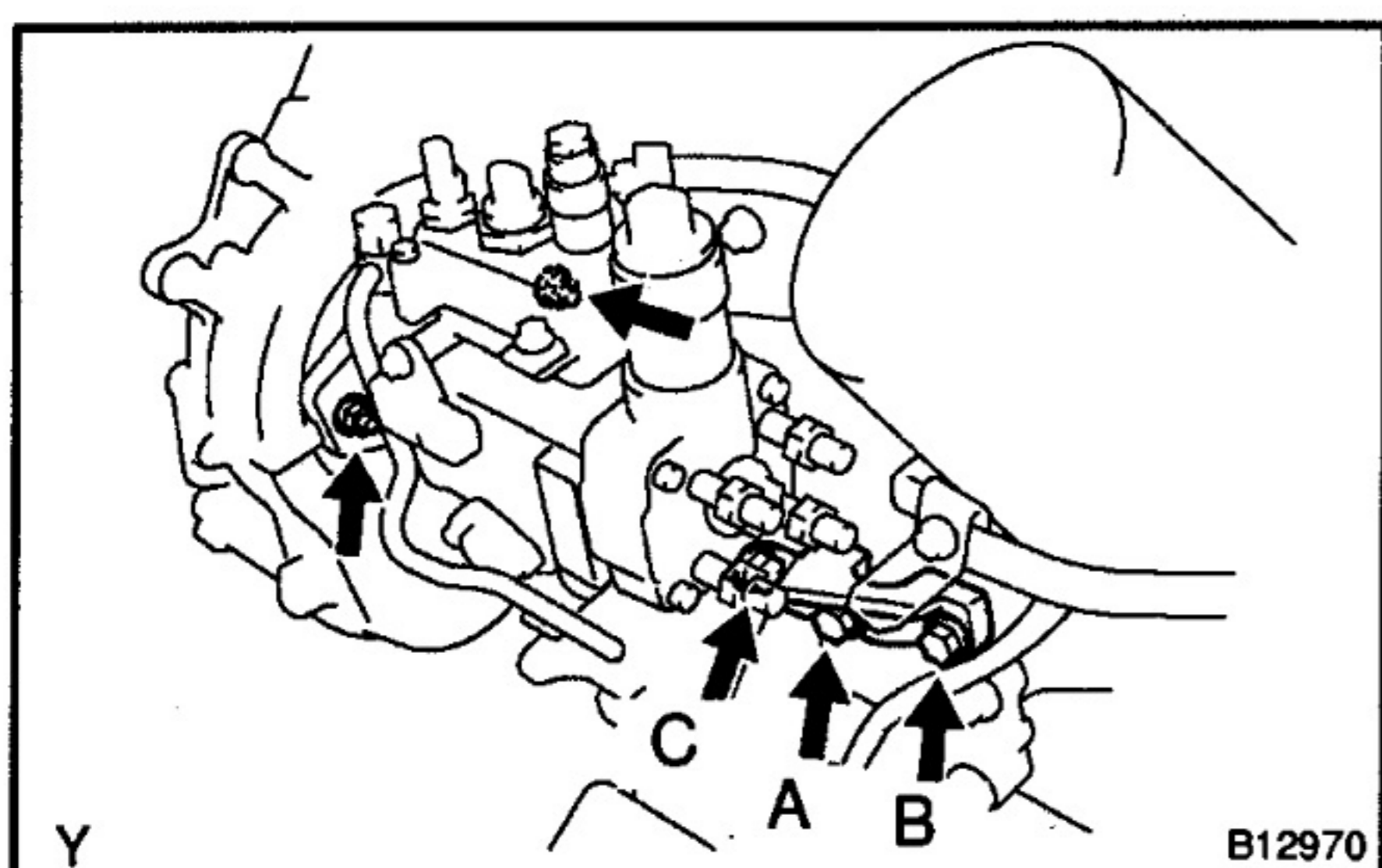
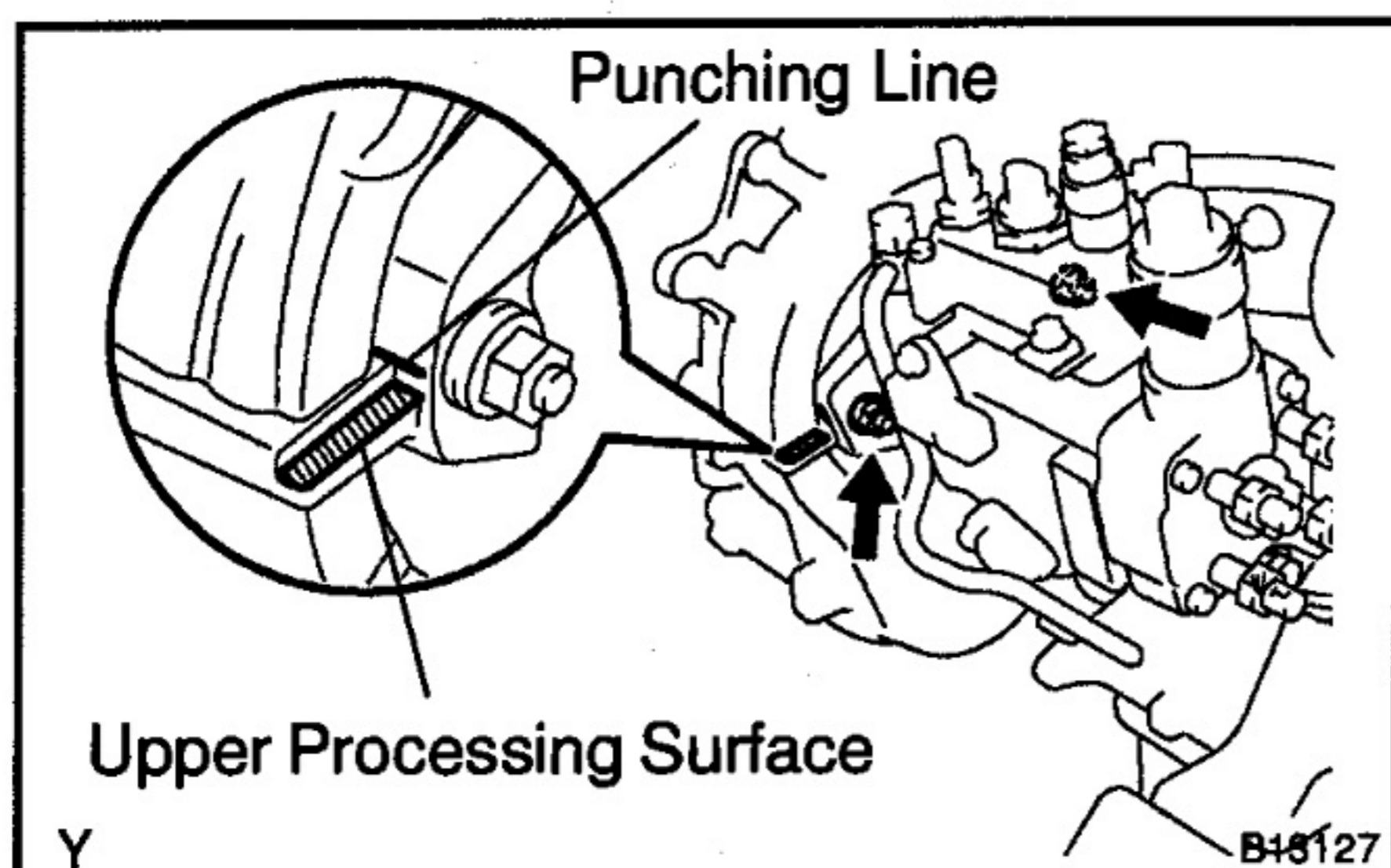
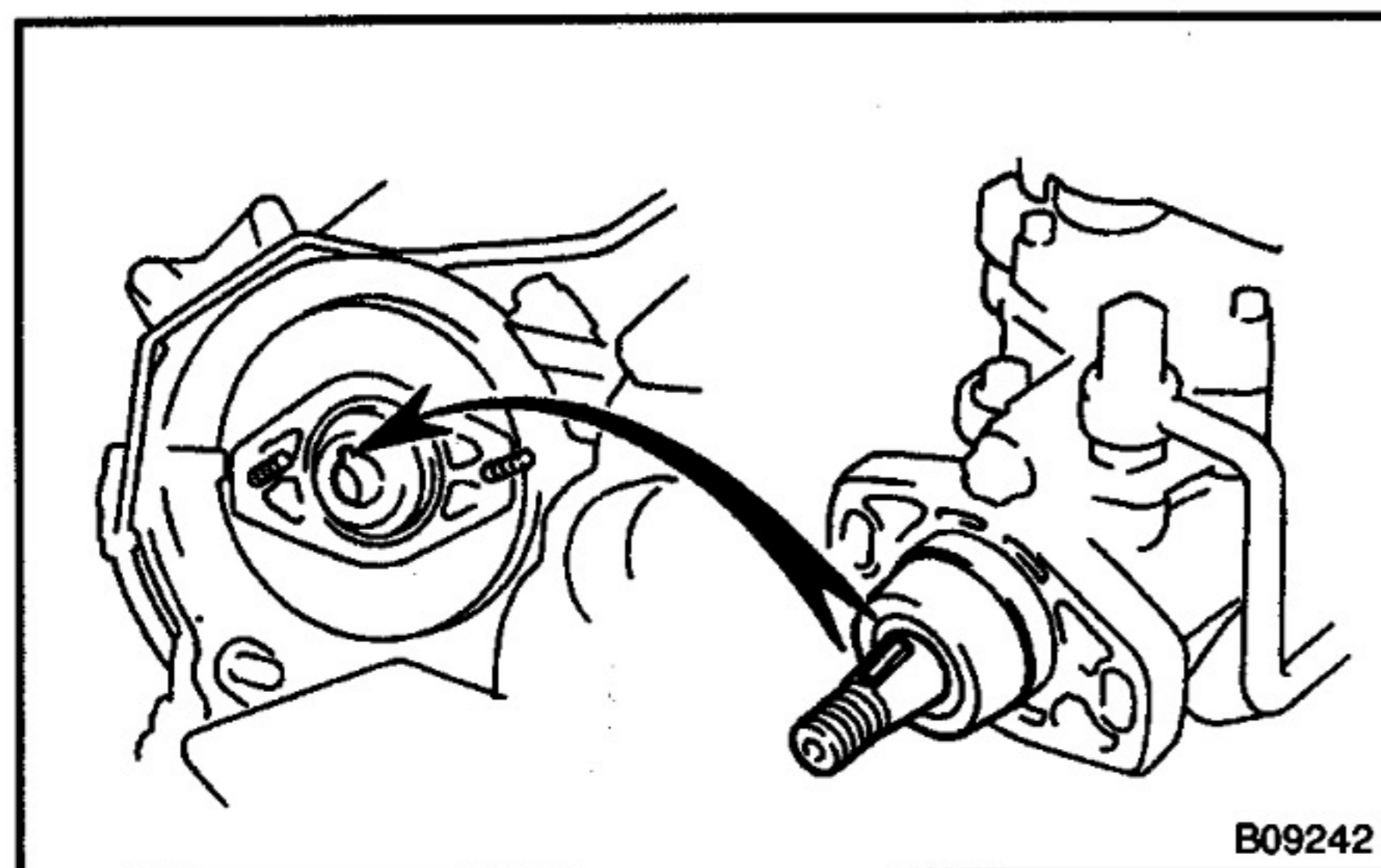

INSTALLATION

1. INSTALL INJECTION PUMP

- (a) Install a new O-ring to the pump.
- (b) Apply a light coat of engine oil on the O-ring.
- (c) Align the set key on the drive shaft and groove of the injection pump drive gear.

- (d) Hold the injection pump with hands and press the injection pump drive gear to the backward and weld it with the injection pump drive shaft.
- (e) Align the punching line of the injection pump flange and the upper processing surface of the timing gear case, and then temporarily install the 2 nuts.
- (f) Tighten the 2 nuts holding the injection pump to the timing gear case.

Torque: 21 N·m (210 kgf·cm, 15 ft·lbf)

- (g) Temporarily install the injection pump stay with the 2 bolts (A, B).
- (h) Install the injection pump stay bolt (C).
Torque: 32 N·m (330 kgf·cm, 24 ft·lbf)
- (i) Tighten the injection pump stay bolts (A, B).
Torque: 21 N·m (210 kgf·cm, 15 ft·lbf)

NOTICE:

Before tightening to the standard torque, check whether the pump stay is up against the injection pump.

- (j) Install the cylinder block insulator.
- (k) Install a new O-ring to the injection pump drive gear.
- (l) Install the injection pump drive gear nut.
- (m) Hold the crankshaft pulley bolt, and tighten the injection pump drive gear nut.

Torque: 64 N·m (650 kgf·cm, 47 ft·lbf)

NOTICE:

Do not turn the crankshaft pulley. The valve heads will hit against the piston top.

- (n) Connect the engine speed sensor connector.
 - (o) Connect the spill control valve connector.
 - (p) Connect the injection pump correction unit connector.
 - (q) Connect the timing control valve connector.
 - (r) Connect the fuel temperature sensor connector.
 - (s) Connect the engine wire clamp and fuel hose.
- ### 2. INSTALL NO. 2 CAMSHAFT TIMING PULLEY (See Pub. No. RM710E, page EM-18)

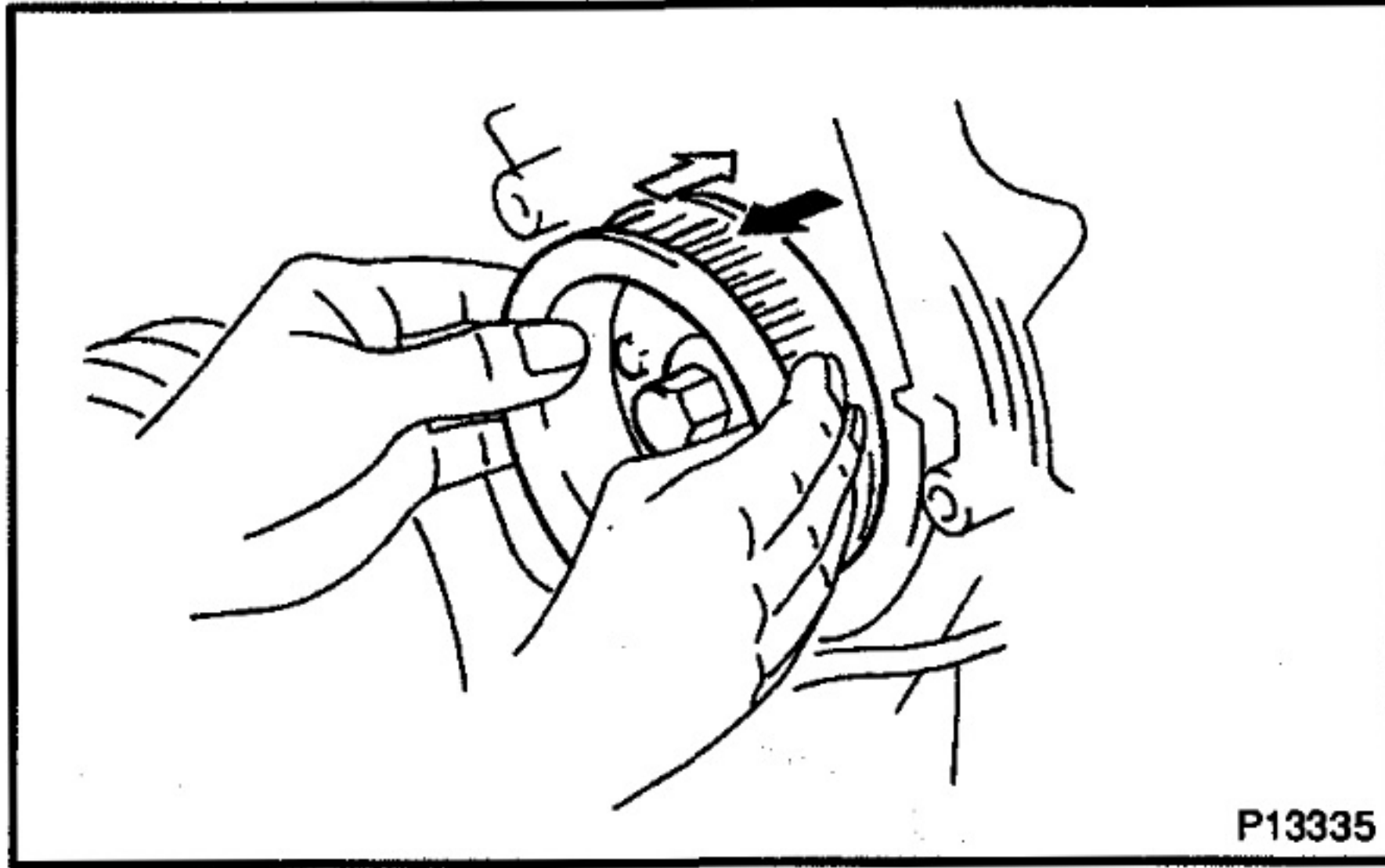

3. CHECK INJECTION PUMP DRIVE SHAFT THRUST CLEARANCE

Move the No. 2 camshaft timing pulley back and forth to check that the injection pump drive shaft has sufficient thrust clearance.

Thrust clearance (Reference):

0.15 – 0.55 mm (0.0059 – 0.0217 in.)

If the thrust clearance is not sufficient, loosen the 2 injection pump nuts and the 3 pump stay bolts, then retighten them.

If the thrust clearance is still not sufficient, remove the timing gear cover and then reinstall it.

4. **INSTALL TIMING BELT (See Pub. No. RM710E, page EM-18)**

5. **INSTALL INJECTION PIPES (See Pub. No. RM710E, page FU-13)**

6. **w/ Intercooler:**

INSTALL INTERCOOLER (See page EM-2)

7. **w/o Intercooler:**

INSTALL INTAKE PIPE (See page EM-2)

COOLING

COOLANT CO-1

REFER TO FOLLOWING REPAIR MANUALS:

Manual Name	Pub. No.
1KZ-T Engine Repair Manual	RM353E
1KZ-TE Engine Repair Manual	RM710E
1KZ-T, 1KZ-TE Engine Repair Manual Supplement	RM522E

NOTE: The above pages contain only the points which differ from the above listed manuals.

COOLANT REPLACEMENT

COOH-03

CAUTION:

To avoid the danger of being burned, do not remove the radiator cap while the engine and radiator are still hot, as fluid and steam can be blown out under pressure.

1. DRAIN ENGINE COOLANT

- (a) Remove the radiator cap.
- (b) Loosen the radiator drain plug (on the right side of the radiator lower tank) and engine drain plug (on the oil cooler cover), and drain the coolant.
- (c) Close the drain plugs.

Torque: 8 N·m (80 kgf·cm, 69 in.-lbf) for engine

2. FILL ENGINE COOLANT

- (a) Slowly fill the system with coolant.
 - Use of improper coolants may damage engine cooling system.
 - Use "Toyota Long Life Coolant" or equivalent and mix it with plain water according to the manufacturer's directions.
 - Using of coolant which includes more than 50 % [freezing protection down to -35°C (-31°F)] or 60 % [freezing protection down to -50°C (-58°F)] of ethylene-glycol is recommended but not more than 70 %.

NOTICE:

- Do not use an alcohol type coolant or plain water alone.
- The coolant should be mixed with plain water (preferably demineralized water or distilled water).

Capacity:

4Runner, Land Cruiser/Land Cruiser Prado

M/T	w/ Rear heater	10.5 liters (11.1 US qts, 9.2 Imp. qts)
	w/o Rear heater	9.5 liters (10.0 US qts, 8.4 Imp. qts)
A/T	w/ Rear heater	11 liters (11.6 US qts, 9.7 Imp. qts)
	w/o Rear heater	10 liters (10.6 US qts, 8.8 Imp. qts)

Hilux

	w/ Rear heater	10.5 liters (11.1 US qts, 9.2 Imp. qts)
	w/o Rear heater	9.5 liters (10.0 US qts, 8.4 Imp. qts)

- (b) Reinstall the radiator cap.
- (c) Start the engine, and bleed the cooling system.
- (d) Refill the radiator reservoir with coolant until it reaches the "full" line.

3. CHECK ENGINE COOLANT FOR LEAKS

4. CHECK ENGINE COOLANT SPECIFIC GRAVITY CORRECTLY

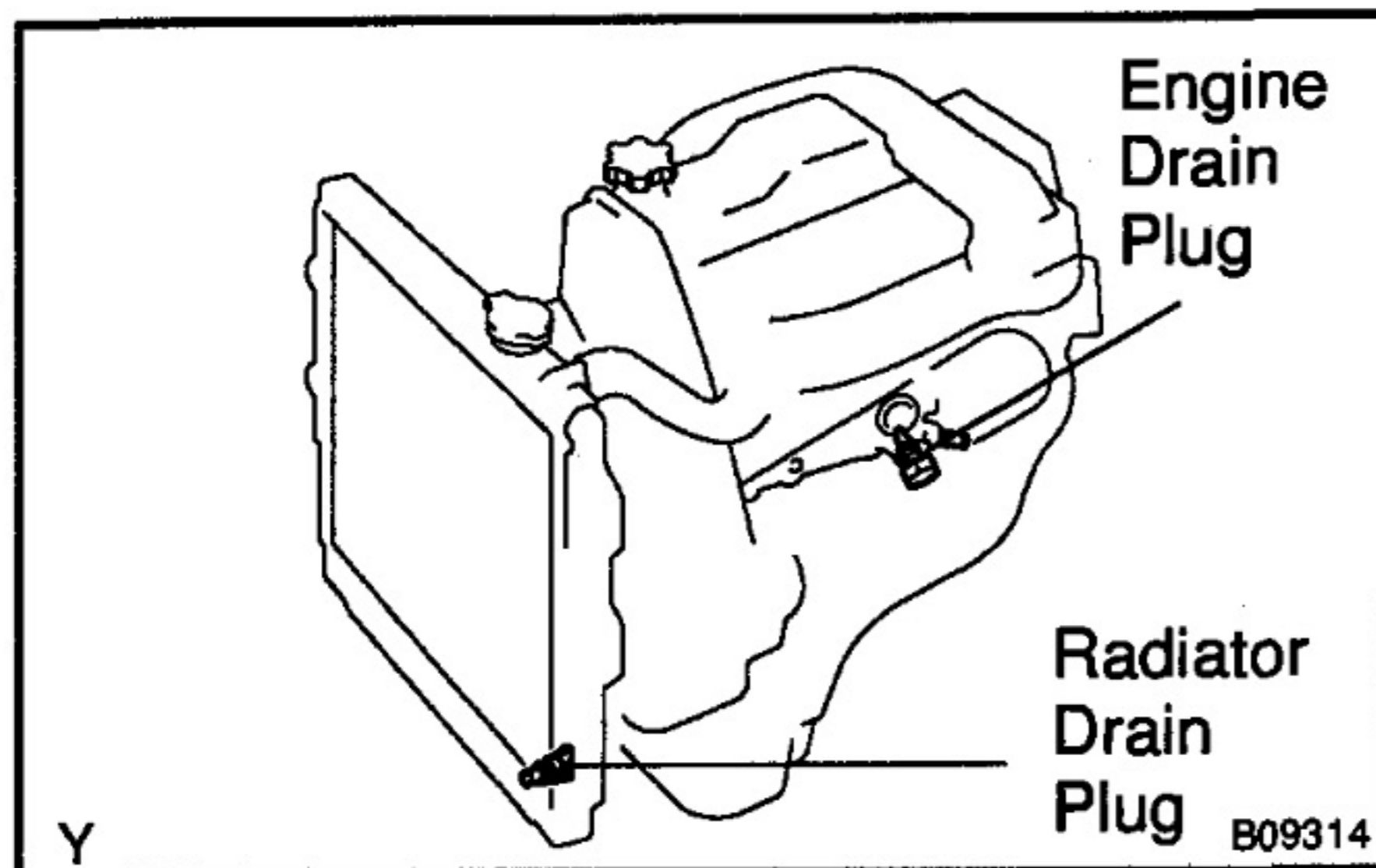

LUBRICATION

OIL AND FILTER	LU-1
OIL PUMP	LU-3

REFER TO FOLLOWING REPAIR MANUALS:

Manual Name	Pub. No.
1KZ-T Engine Repair Manual	RM353E
1KZ-TE Engine Repair Manual	RM710E
1KZ-T, 1KZ-TE Engine Repair Manual Supplement	RM522E

NOTE: The above pages contain only the points which differ from the above listed manuals.

OIL AND FILTER REPLACEMENT

LU0HW-02

CAUTION:

- Prolonged and repeated contact with mineral oil will result in the removal of natural fats from the skin, leading to dryness, irritation and dermatitis. In addition, used engine oil contains potentially harmful contaminants which may cause skin cancer.
- Care should be taken, therefore, when changing engine oil to minimize the frequency and length of time your skin is exposed to used engine oil. Protective clothing and gloves that cannot be penetrated by oil should be worn. The skin should be thoroughly washed with soap and water, or use water-less hand cleaner, to remove any used engine oil. Do not use gasoline, thinners, or solvents.
- In order to preserve the environment, used oil and used oil filter must be disposed of only at designated disposal sites.

1. DRAIN ENGINE OIL

- Remove the oil filter cap.
- Remove the oil drain plug, and drain the oil into a container.

LU

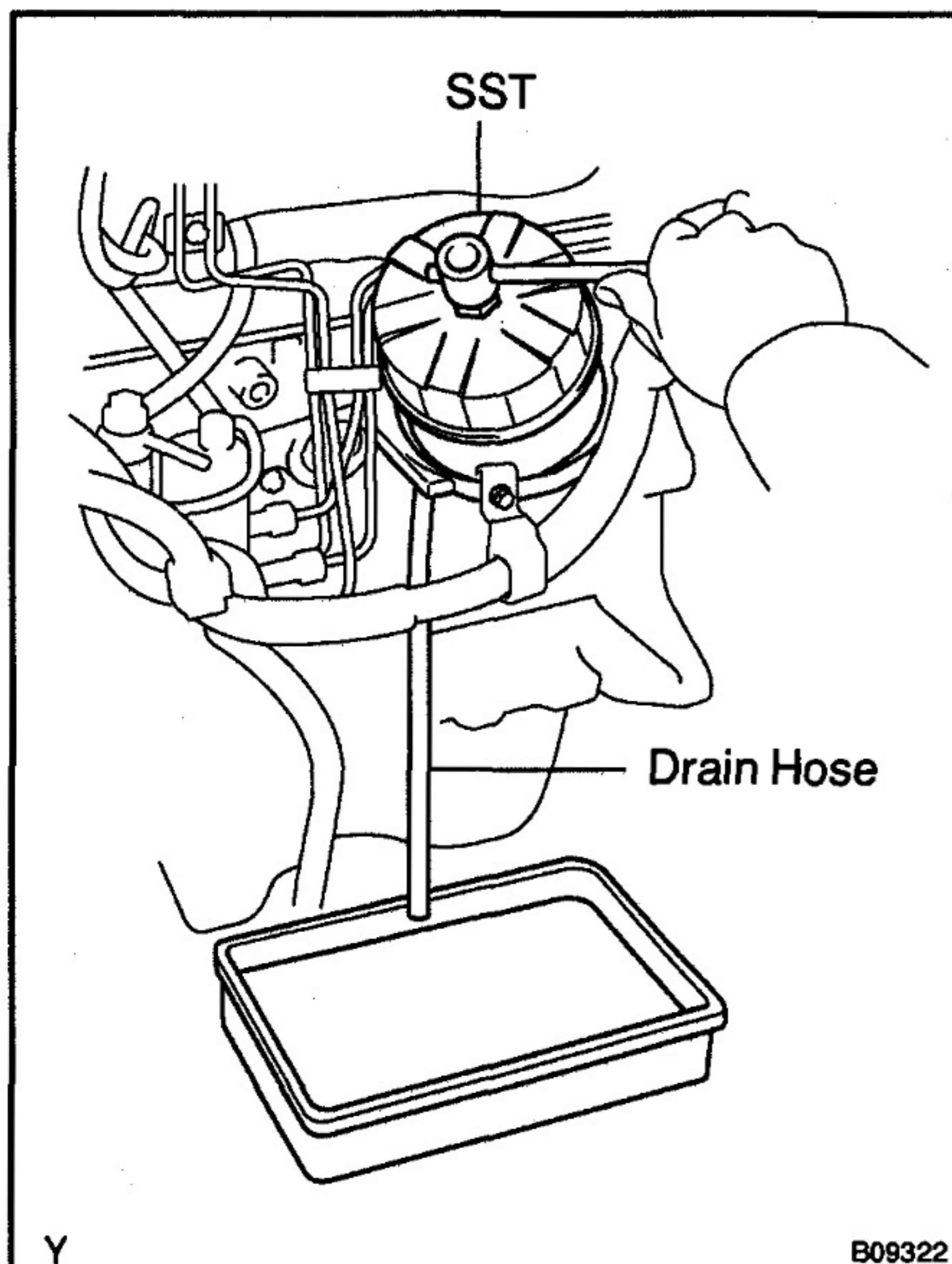

2. REPLACE OIL FILTER

- Using SST, remove the oil filter.
SST 09228-10002

HINT:

As the oil in the filter flows out through the drain hose, place the drain oil container under the drain hose.

- Clean the oil filter contact surface on the oil filter mounting.
- Lubricate the filter rubber gasket with clean engine oil.

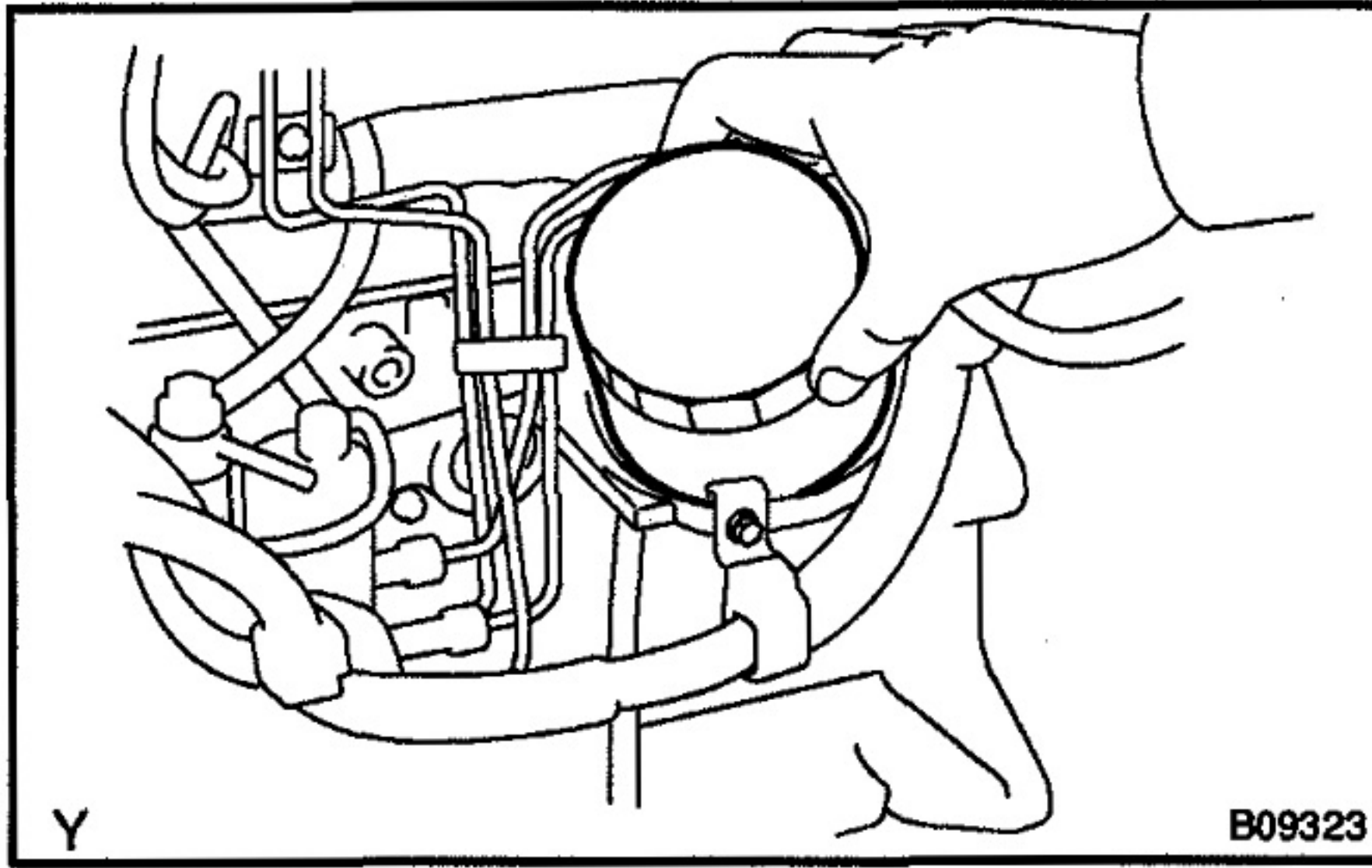

- (d) Tighten the oil filter by hand until the rubber gasket contacts the seat of the filter mounting.

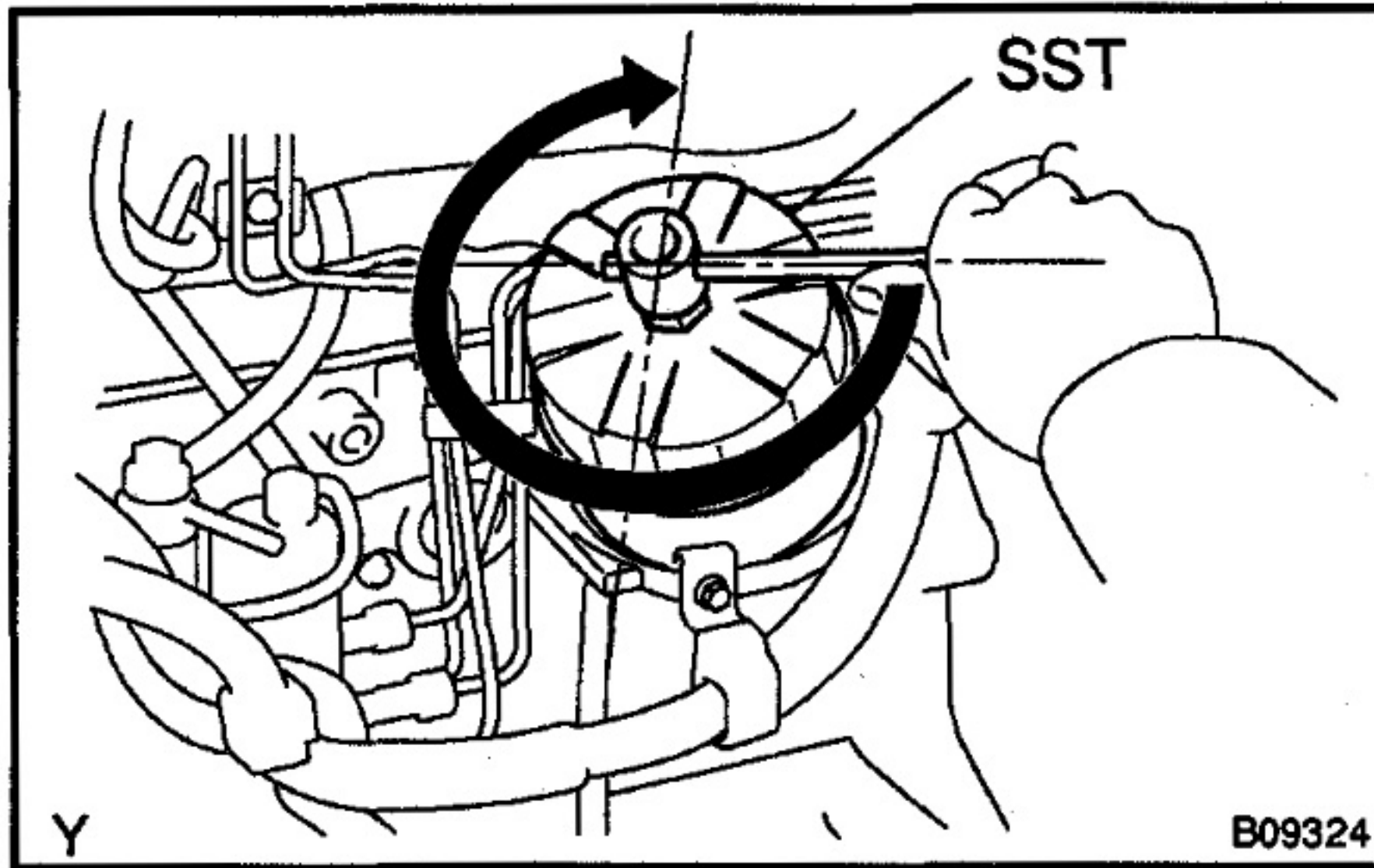

- (e) Using SST, give it an additional 3/4 turn to seat the filter.
SST 09228-10002

3. FILL WITH ENGINE OIL

- (a) Clean and install the oil drain plug with a new gasket.
Torque: 34 N·m (350 kgf·cm, 25 ft·lbf)
- (b) Fill with fresh engine oil.

Capacity:

4Runner, Land Cruiser/Land Cruiser Prado

Drain and refill	w/ Oil filter change	7.0 liters (7.4 US qts, 6.2 Imp. qts)
	w/o Oil filter change	6.4 liters (6.8 US qts, 5.6 Imp. qts)
Dry fill		7.5 liters (7.9 US qts, 6.6 Imp. qts)

Hilux

Drain and refill	w/ Oil filter change	7.1 liters (7.5 US qts, 6.2 Imp. qts)
	w/o Oil filter change	6.4 liters (6.8 US qts, 5.6 Imp. qts)
Dry fill		7.6 liters (8.0 US qts, 6.7 Imp. qts)

- (c) Reinstall the oil filter cap.

4. START ENGINE AND CHECK FOR OIL LEAKS

5. RECHECK ENGINE OIL LEVEL

OIL PUMP COMPONENTS

LU0HX-02

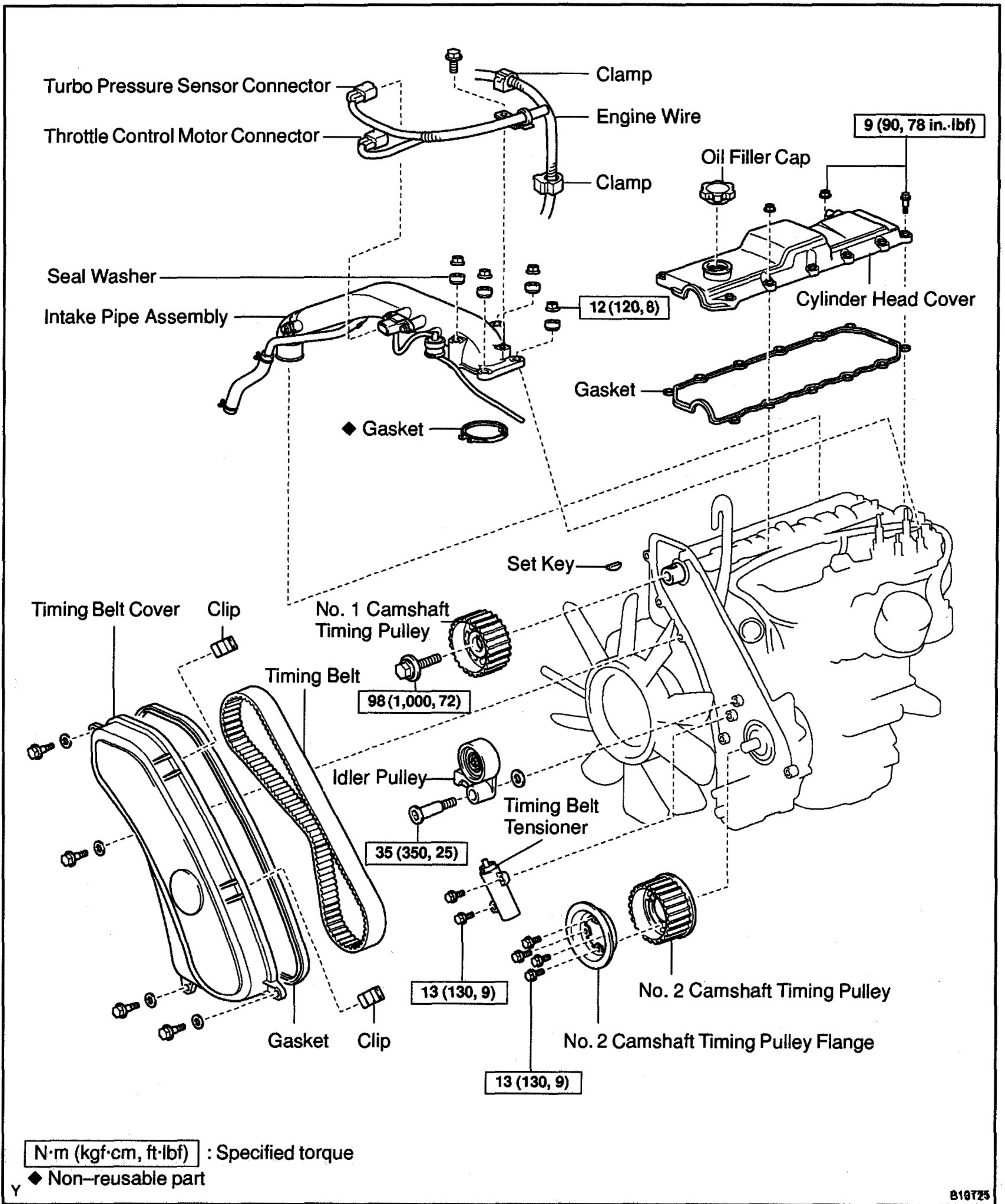

LU

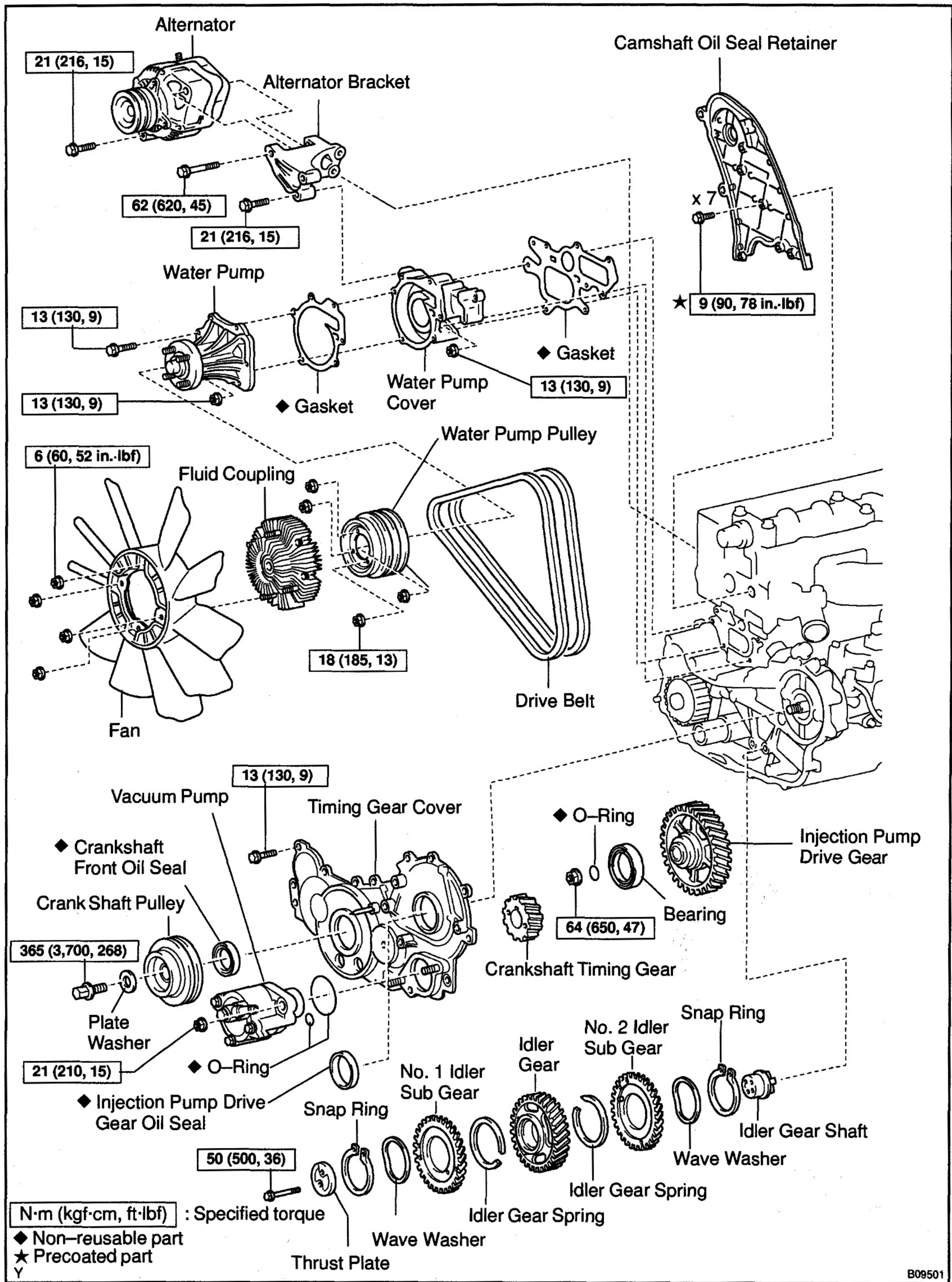

LU

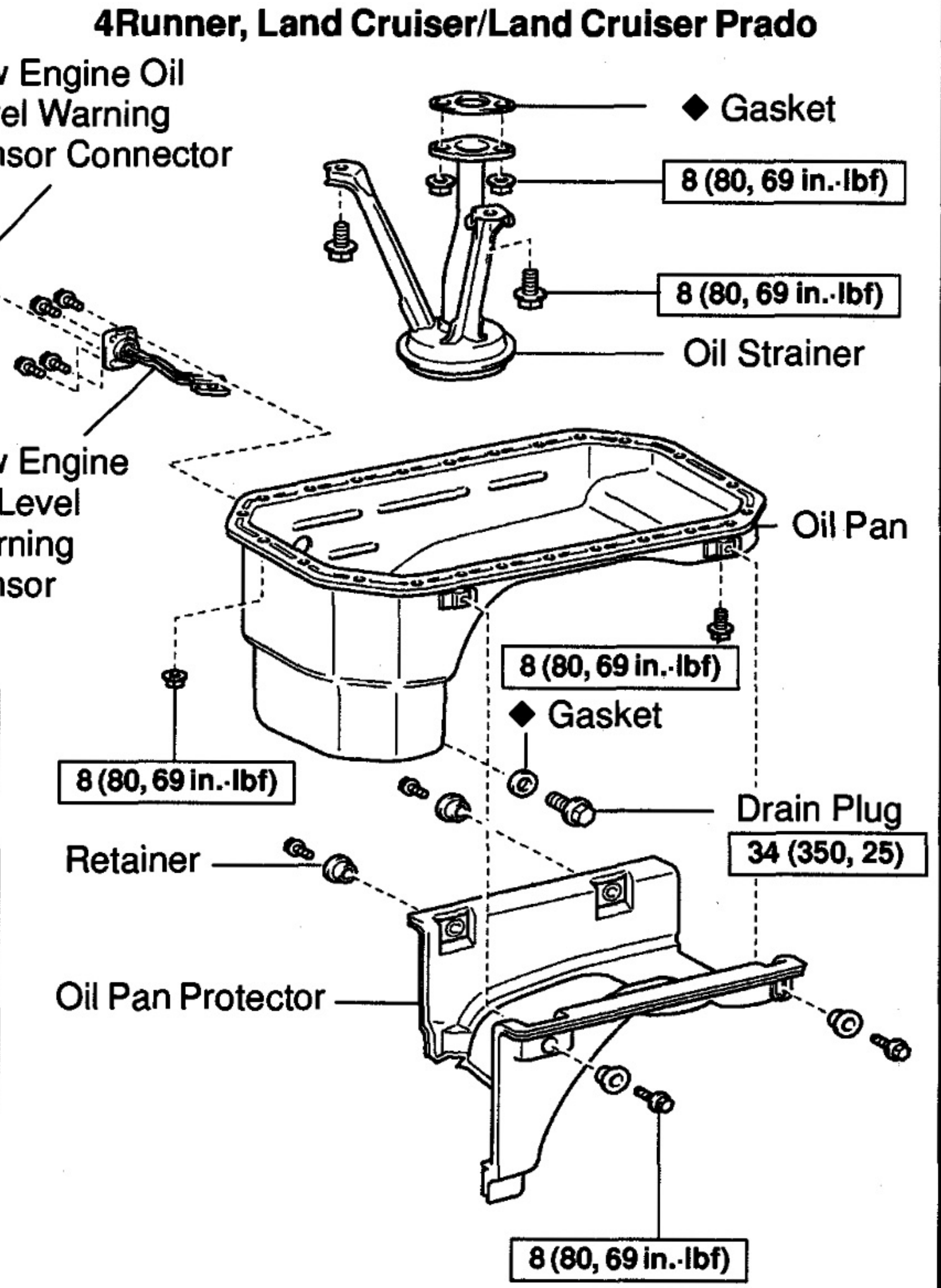
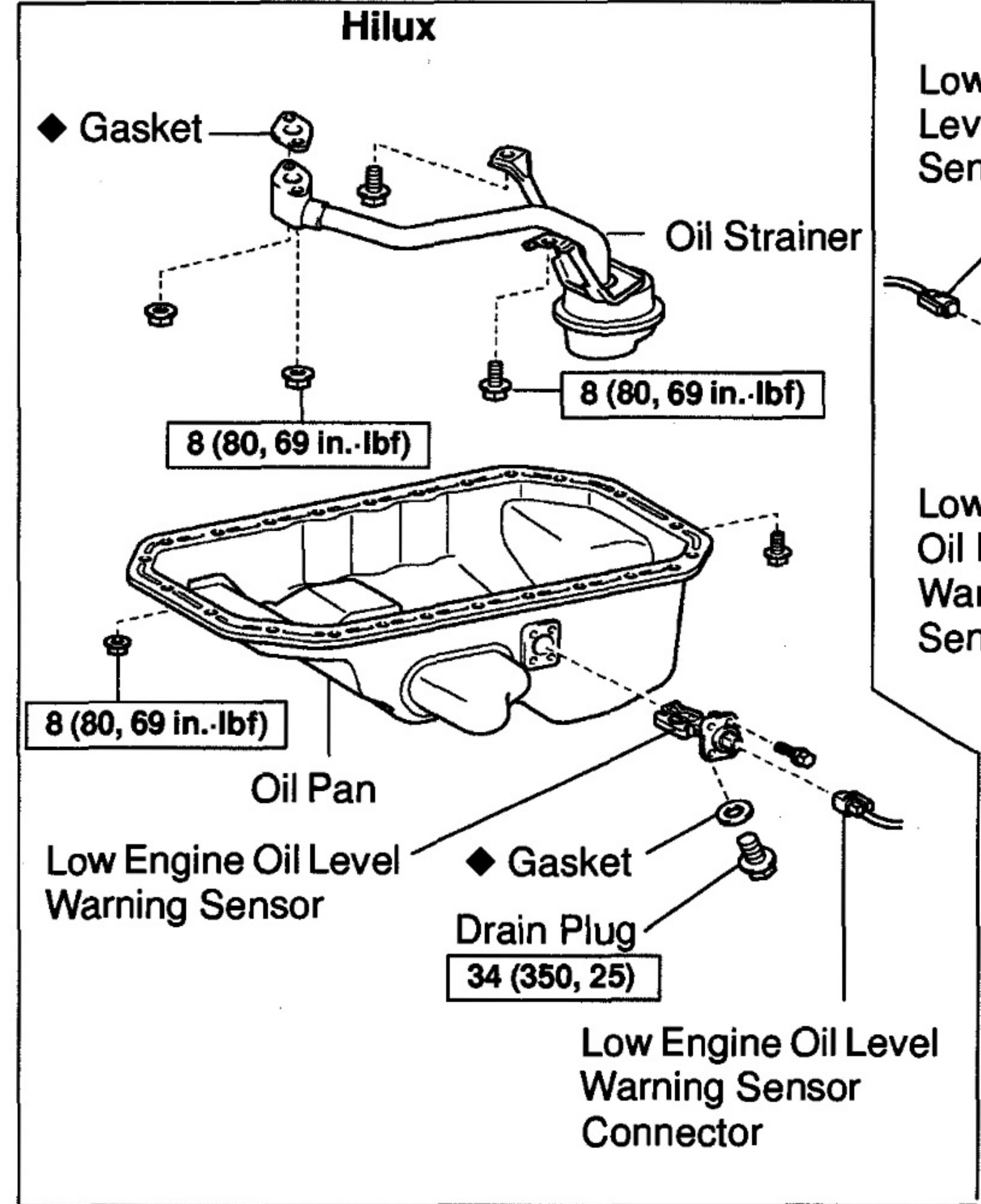
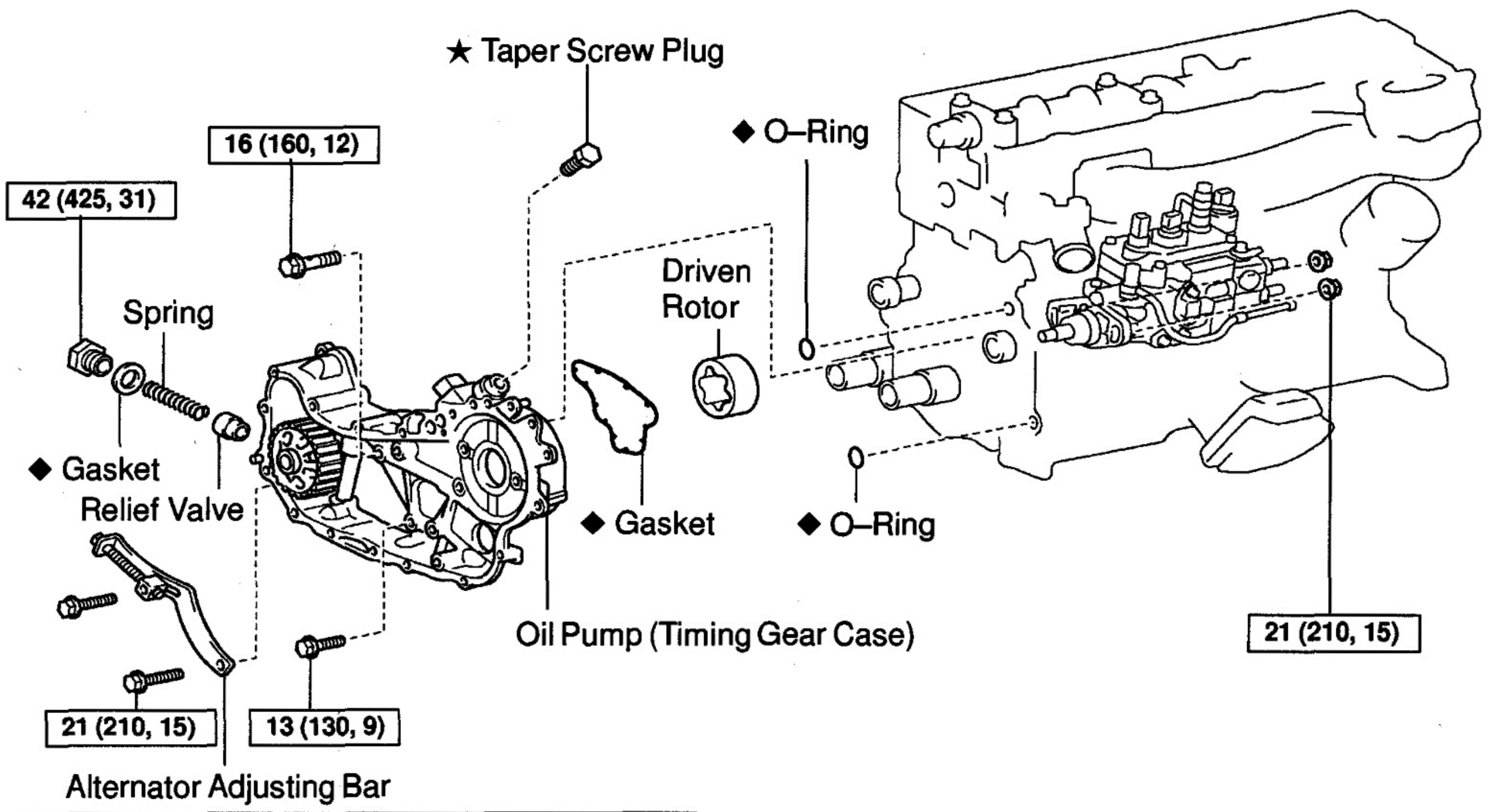

Y [N·m (kgf·cm, ft·lbf)] : Specified torque

◆ Non-reusable part

★ Precoated part

LU

STARTING

PRE-HEATING SYSTEM ST-1

REFER TO FOLLOWING REPAIR MANUALS:

Manual Name	Pub. No.
1KZ-T Engine Repair Manual	RM353E
1KZ-TE Engine Repair Manual	RM710E
1KZ-T, 1KZ-TE Engine Repair Manual Supplement	RM522E

NOTE: The above pages contain only the points which differ from the above listed manuals.

PRE-HEATING SYSTEM INSPECTION

ST0ML-01

1. INSPECT LIGHTING TIME OF GLOW INDICATOR LIGHT

Turn the ignition switch ON, measure the lighting time.

Light lighting time (T1): Refer to the chart graph

2. INSPECT AFTER GLOW TIME

Turn the ignition switch ON, measure the time battery voltage is applied to terminal SREL of the preheating timer.

After glow time (T2): Refer to the chart graph

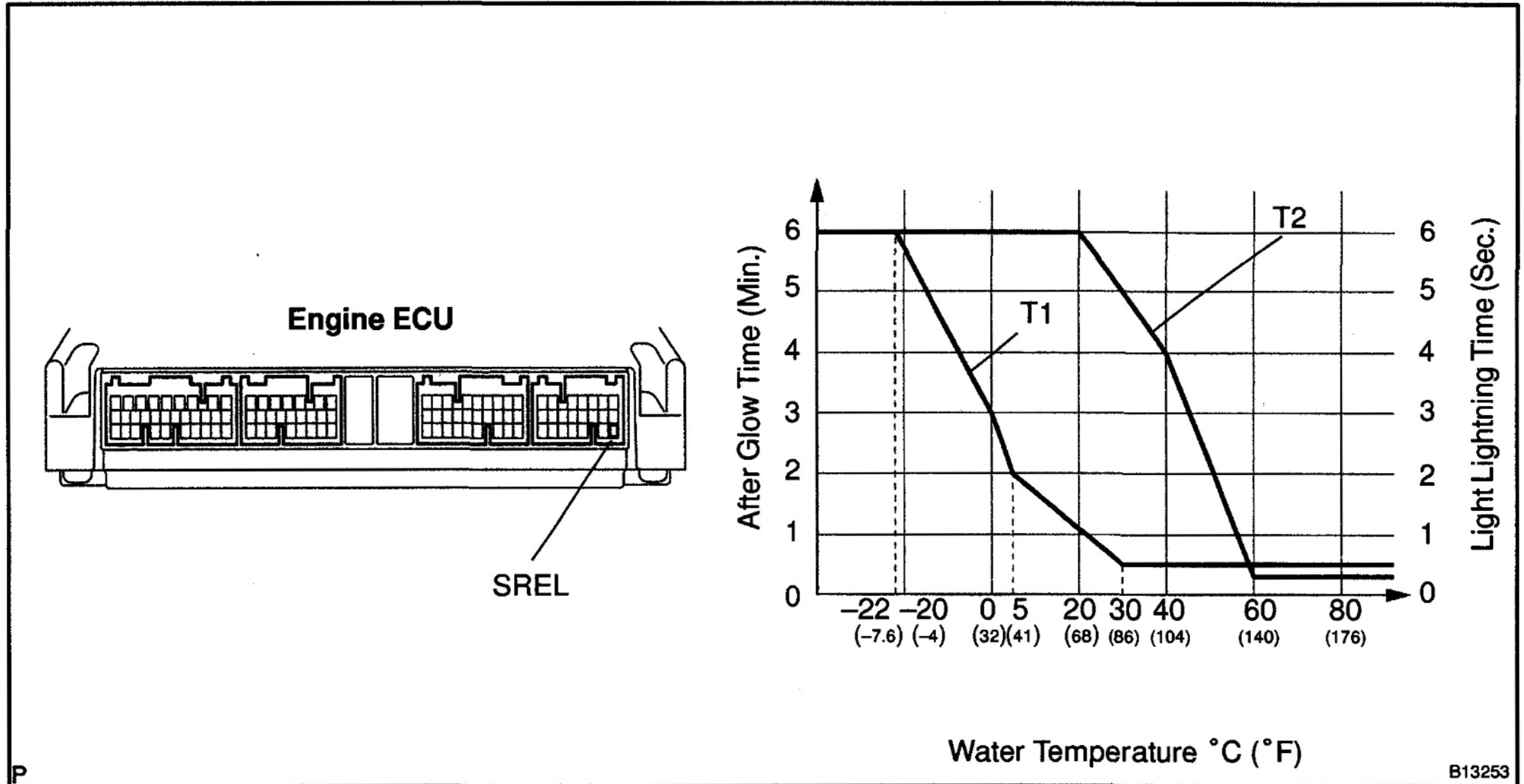

ST

3. INSPECT ENGINE ECU (See page DI-18)

ALPHABETICAL INDEX

ID

A

	Page
ABBREVIATIONS USED IN THIS MANUAL (TERMS)	IN-25
ACCELERATOR PEDAL	
CLOSED POSITION SWITCH	ED-20
ACCELERATOR PEDAL POSITION SENSOR	ED-18

C

CIRCUIT INSPECTION (ENGINE) (DIAGNOSTICS)	DI-26
COOLANT	CO-1
COOLING (PREPARATION)	PP-14
CUSTOMER PROBLEM ANALYSIS CHECK (ENGINE) (DIAGNOSTICS)	DI-3
CYLINDER BLOCK	EM-8
CYLINDER HEAD	EM-2

D

DIAGNOSTIC TROUBLE CODE CHART (ENGINE) (DIAGNOSTICS)	DI-14
--	-------

E

E-VRV FOR EGR (w/ EGR)	ED-10
ELECTRONIC CONTROL DIESEL (PREPARATION)	PP-8
ELECTRONIC CONTROL DIESEL (SERVICE SPECIFICATIONS)	SS-10
EMISSION CONTROL (PREPARATION)	PP-6
EMISSION CONTROL (SERVICE SPECIFICATIONS)	SS-8
ENGINE (DIAGNOSTICS)	DI-1
ENGINE FUEL (PREPARATION)	PP-11
ENGINE FUEL (SERVICE SPECIFICATIONS)	SS-12
ENGINE MECHANICAL (PREPARATION)	PP-1
ENGINE MECHANICAL (SERVICE SPECIFICATIONS)	SS-4
ENGINE SERIAL NUMBER (IDENTIFICATION INFORMATION)	IN-3
ENGINE SPEED SENSOR	ED-17
EXHAUST GAS RECIRCULATION (EGR) SYSTEM (w/ EGR)	EC-3

F

FIRST GEAR POSITION SWITCH (M/T)	ED-21
FOR ALL OF VEHICLES	IN-8
FUEL HEATER	FU-1
FUEL TEMPERATURE SENSOR	ED-12

G

GENERAL INFORMATION (HOW TO TROUBLESHOOT ECU CONTROLLED SYSTEMS)	IN-9
GENERAL INFORMATION (HOW TO USE THIS MANUAL)	IN-1
GENERAL INFORMATION (REPAIR INSTRUCTIONS)	IN-4

H

	Page
HOW TO PROCEED WITH TROUBLESHOOTING (ENGINE) (DIAGNOSTICS)	DI-1
HOW TO PROCEED WITH TROUBLESHOOTING (HOW TO TROUBLESHOOT ECU CONTROLLED SYSTEMS)	IN-10
HOW TO TROUBLESHOOT ECU CONTROLLED SYSTEMS	IN-9
HOW TO USE THE DIAGNOSTIC CHART AND INSPECTION PROCEDURE (HOW TO TROUBLESHOOT ECU CONTROLLED SYSTEMS)	IN-20
HOW TO USE THIS MANUAL	IN-1

I

IDENTIFICATION INFORMATION	IN-3
IDLE SPEED AND MAXIMUM SPEED	EM-1
INJECTION NOZZLE	FU-3
INJECTION PUMP	FU-5
INJECTION PUMP CORRECTION UNIT	ED-23
INTAKE AIR TEMPERATURE SENSOR	ED-13
INTERCOOLER	TC-10

L

LUBRICATION (PREPARATION)	PP-15
LUBRICATION (SERVICE SPECIFICATIONS)	SS-14

O

OIL AND FILTER	LU-1
OIL PUMP	LU-3

P

PARTS LAYOUT AND SCHEMATIC DRAWING	EC-1
PARTS LOCATION (ENGINE) (DIAGNOSTICS)	DI-16
PRE-CHECK (ENGINE) (DIAGNOSTICS)	DI-4
PRE-HEATING SYSTEM	ST-1
PRECAUTION (FOR ALL OF VEHICLES)	IN-8
PROBLEM SYMPTOMS TABLE (ENGINE) (DIAGNOSTICS)	DI-24

R

REPAIR INSTRUCTIONS	IN-4
---------------------------	------

S

SPILL CONTROL VALVE	ED-9
STANDARD BOLT (SERVICE SPECIFICATIONS)	SS-1
STARTING (SERVICE SPECIFICATIONS)	SS-15

T

TERMINALS OF ECU (ENGINE) (DIAGNOSTICS)	DI-18
TERMS	IN-25
THROTTLE BODY	ED-1
TIMING CONTROL VALVE	ED-8
TURBO PRESSURE SENSOR	ED-14
TURBOCHARGER	TC-1
TURBOCHARGING (PREPARATION)	PP-3
TURBOCHARGING (SERVICE SPECIFICATIONS) ...	SS-6