



# TOYOTA LAND CRUISER

KZJ95R

## AIR CONDITIONING

DENSO INTERNATIONAL AUSTRALIA PTY LTD

MAC-A510

INSTALLATION MANUAL

# INTRODUCTION

## IMPORTANT NOTICE

This manual has been designed for technicians who are qualified and educated in the proper procedures of vehicle safety, handling and maintenance; experienced in installation of car air conditioning or who are able to carry out installation procedures when given instructions by an experienced technician in a supervisory capacity; and are certified to handling refrigerant.

1. Take special care to ensure that clearance between air conditioning components and other components such as brake parts, fuel system and electric wires as specified in this manual.
2. If a problem is found with the air conditioning system due to installation, refer back to the manual to correct the problem(s).
3. Vehicle and air conditioning kit components as well as installation procedures are subject to change without prior notice. Refer to the latest installation manual and service information. Any changes affecting the above items will be given in the form of a "Installation instructions for air conditioning (Supplement)" (issued by DENSO) or a service bulletin (issued by the manufacturer).

## DEFINITION OF TERMS

**! WARNING** : Describes precautions that should be observed in order to prevent injury or death to the user during installation.

**! CAUTION** : Describes precautions that should be observed in order to prevent damage to the vehicle or its components, which may occur during installation if insufficient care is taken.

**NOTE** : Provides additional information that facilitates installation work.

**FRONT, REAR** : Shows the direction when viewed from the driver's seat.

**LEFT, RIGHT**

© 1999 DENSO CORPORATION.

All Rights Reserved. This book may not be reproduced or copied, in whole or in part, without the written permission of the publisher.

# FOREWORD

This manual has been published to explain how to install the air conditioning for TOYOTA LANDCRUISER (1KZ-TE E/G). When installing the air conditioning, installation should be performed as described in this manual.

[APPLICATION VEHICLE]

| VEHICLE NAME | MODEL CODE | PRODUCTION PERIOD | ENGINE TYPE | STEERING POSITION | DESTINATION |
|--------------|------------|-------------------|-------------|-------------------|-------------|
| LANDCRUISER  | KZJ95R     | 2000.1~           | 1KZ-TE      | RHD               | AUSTRALIA   |

## TABLE OF CONTENTS

|   |    |
|---|----|
| 1. GENERAL INFORMATION .....                        | 1  |
| 1-1 PRECAUTIONS DURING INSTALLATION .....           | 1  |
| 1-2 INSTALLATION PREPARATION .....                  | 1  |
| 1-3 TIGHTENING TORQUE .....                         | 2  |
| 1-4 PRECAUTIONS FOR SAFETY INSTALLATION .....       | 4  |
| 1-5 PIPE JOINT PRECAUTIONS .....                    | 9  |
| 1-6 GENERAL PRECAUTIONS IN ASSEMBLY .....           | 10 |
| 1-7 CHARGING REFRIGERANT (HFC-134a) .....           | 11 |
| 1-8 QUICK JOINT REMOVER INSTRUCTIONS .....          | 14 |
| 2. INSTALLATION .....                               | 15 |
| 2-1 INSTALLATION INSIDE PASSENGER COMPARTMENT ..... | 15 |
| 2-2 INSTALLATION INSIDE ENGINE COMPARTMENT .....    | 20 |
| 3. AFTER INSTALLATION .....                         | 31 |
| 3-1 CHARGING REFRIGERANT (HFC-134a) .....           | 31 |
| 3-2 FINAL LEAKAGE CHECK .....                       | 32 |
| 3-3 RE-ADJUSTMENT OF COMPRESSOR BELT .....          | 33 |
| 3-4 RESTORE THE VEHICLE .....                       | 34 |
| 3-5 FINAL INSPECTION (SAFETY CHECK) .....           | 34 |
| 4. WIRING DIAGRAM .....                             | 35 |

# 1. GENERAL INFORMATION

## 1-1 PRECAUTIONS DURING INSTALLATION

### !WARNING

1. The contents given in “**WARNING**” and “**CAUTION**” in this manual must be adhered to during installation. If they are ignored, not only the functions of the air conditioning are hindered, but also personal injury or damage to the vehicle may result. Always carry out the installation in accordance with the “**WARNING**” and “**CAUTION**” as noted.
2. Safety Precautions
  - (a) If installation is carried out by more than two persons, always pay attention to co-worker’s safety.
  - (b) When the engine is running, make sure that sufficient ventilation is provided.
  - (c) Take special care when working with heated, rotating, sliding, or moving parts, to prevent bodily injury.
  - (d) When raising the vehicle, refer to the appropriate manufacturer’s service manual.
  - (e) For heavy duty trucks, when tilting the cabin forward, refer to the service manual provided by the vehicle’s manufacturer to prevent damage or personal injury. Make sure the cabin is locked down after it has been tilted forward to prevent it from closing.

## 1-2 INSTALLATION PREPARATION

- (1) Prior to installing the air conditioning, check the following for damage or malfunctions.
  - (a) Internal and external trim and bodywork.
  - (b) Engine idle speed.
  - (c) Engine cooling system.
  - (d) All vehicle functions. (Headlights, indicators, horn, etc.)
- (2) Air Conditioning parts preparation
  - (a) Make sure that the correct kit has been selected for the installation.
  - (b) When unpacking the kit, lay out all parts in order of installation and check for missing or damaged parts.
  - (c) When installing the air conditioning, use fender covers, floor covers and seat covers for protection.

### [INSTALLATION TOOLS]

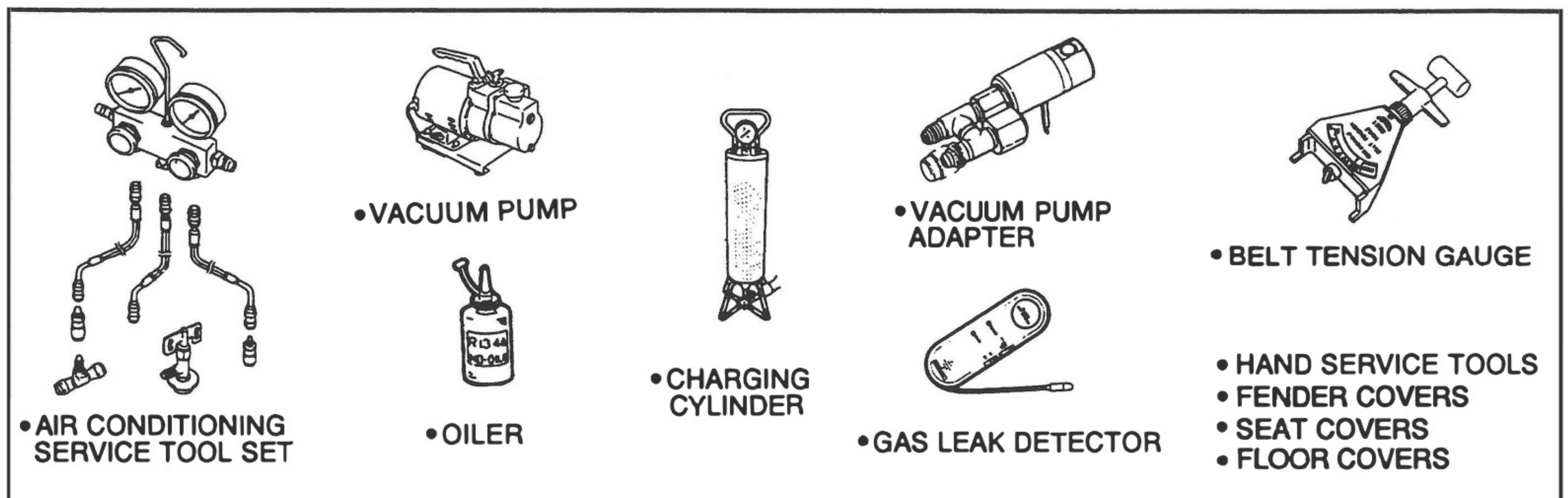

## 1-3 TIGHTENING TORQUE

- (1) Where tightening torque is specified, always tighten there with the specified torque.
- (2) Where tightening torque is not specified, refer to the tightening torque table.
- (3) Bolts marked with 8 must be used for engine components, which are likely to be subject to heavy load. Never substitute the bolts marked 8 with other bolts.
- (4) Nuts must be fastened with the tightening torque specified for the related bolts.



### [TIGHTENING TORQUE TABLE (GENERAL)]

| [Unit : N•m]    |            |            |            |            |            |            |            |
|-----------------|------------|------------|------------|------------|------------|------------|------------|
| Diam. (mm)      | Pitch (mm) | 4T         | 5T         | 6T         | 7T         | 8T         | 10T        |
| 6               | 1.00       | 5.4± 1.0   | 6.4± 1.1   | 7.8± 1.4   | 10.8± 1.9  | —          | —          |
| 8               | 1.25       | 12.7± 2.5  | 15.7± 2.9  | 19.1± 3.4  | 25.5± 5.9  | 29.4± 5.9  | 38.2± 7.4  |
| 10              | 1.25       | 25.5± 4.9  | 32.4± 6.3  | 39.2± 7.8  | 52.0±10.2  | 60.8±11.8  | 78.5±15.6  |
| 12              | 1.25       | 47.1± 9.3  | 58.8±11.7  | 71.6±14.2  | 95.1±18.6  | 107.9±21.5 | 142.2±28.3 |
| 14              | 1.50       | 74.5±14.7  | 91.2±18.1  | 107.9±21.6 | 147.1±29.4 | —          | —          |
| 16              | 1.50       | 112.8±22.5 | 137.3±27.5 | 171.6±34.3 | 225.6±45.1 | —          | —          |
| [Unit : kgf•cm] |            |            |            |            |            |            |            |
| Diam. (mm)      | Pitch (mm) | 4T         | 5T         | 6T         | 7T         | 8T         | 10T        |
| 6               | 1.00       | 55± 10     | 65± 10     | 80± 15     | 110± 20    | —          | —          |
| 8               | 1.25       | 130± 25    | 160± 30    | 195± 35    | 260± 50    | 300± 60    | 390± 75    |
| 10              | 1.25       | 260± 50    | 330± 65    | 400± 80    | 530± 105   | 620± 120   | 800± 160   |
| 12              | 1.25       | 480± 95    | 600± 120   | 730± 145   | 970± 190   | 1100± 220  | 1450± 290  |
| 14              | 1.50       | 760± 150   | 930± 185   | 1100± 220  | 1500± 300  | —          | —          |
| 16              | 1.50       | 1150± 230  | 1400± 280  | 1750± 350  | 2300± 460  | —          | —          |
| [Unit : ft•lbf] |            |            |            |            |            |            |            |
| Diam. (mm)      | Pitch (mm) | 4T         | 5T         | 6T         | 7T         | 8T         | 10T        |
| 6               | 1.00       | 4.0± 0.7   | 4.7± 0.7   | 5.8± 1.0   | 7.9± 1.3   | —          | —          |
| 8               | 1.25       | 9.4± 1.8   | 11.5± 2.1  | 14.1± 2.4  | 18.7± 3.6  | 21.7± 4.3  | 28.1± 5.4  |
| 10              | 1.25       | 18.8± 3.6  | 23.8± 4.6  | 29.0± 5.7  | 38.2± 7.4  | 44.8± 8.6  | 56.7±11.4  |
| 12              | 1.25       | 37.4± 6.8  | 43.2± 8.5  | 52.8±10.4  | 69.9±13.6  | 79.6±15.7  | 104.5±20.7 |
| 14              | 1.50       | 54.7±10.8  | 67.0±13.2  | 79.3±15.8  | 108.1±21.6 | —          | —          |
| 16              | 1.50       | 82.9±16.5  | 100.9±20.2 | 126.0±25.2 | 165.7±33.1 | —          | —          |

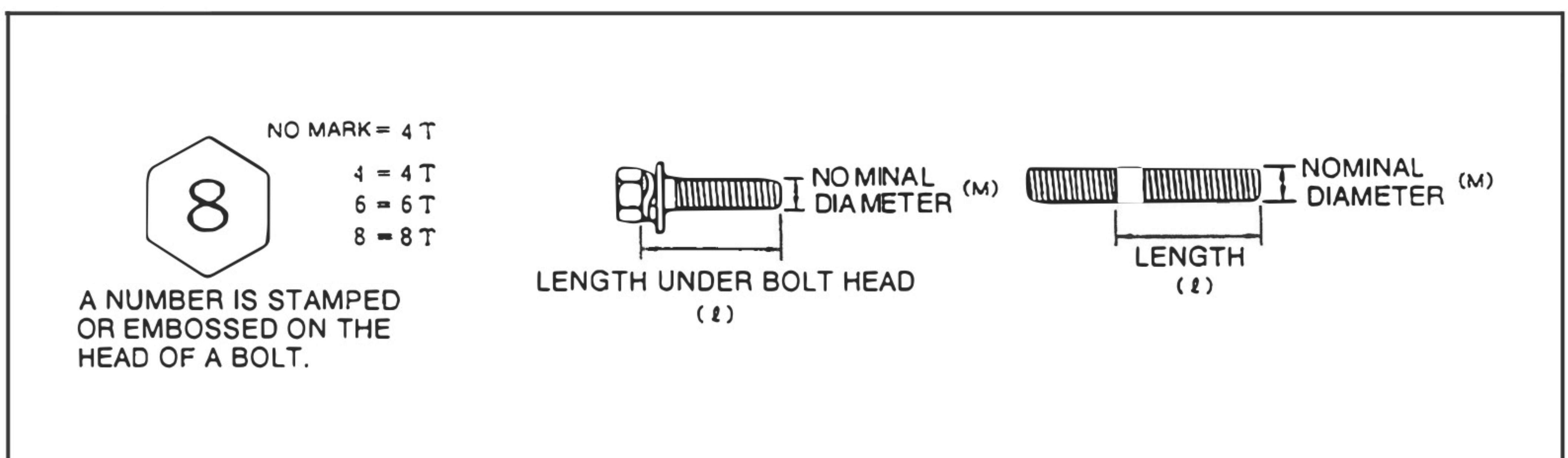
### [IDENTIFICATION OF BOLT STRENGTH (BOLT SIZES)]

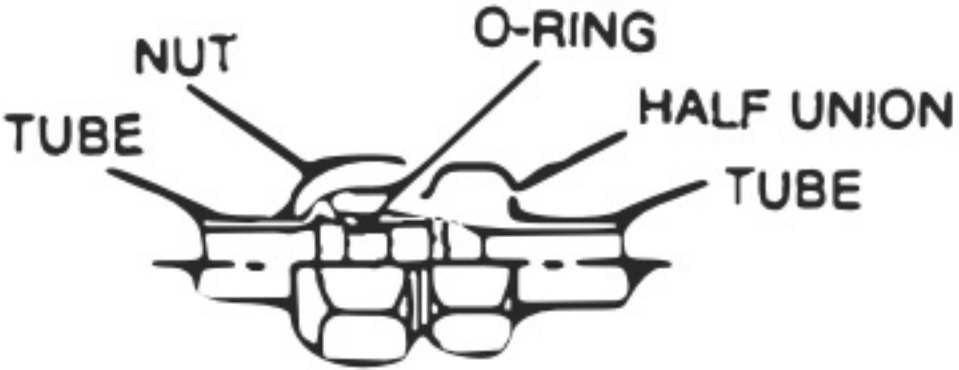
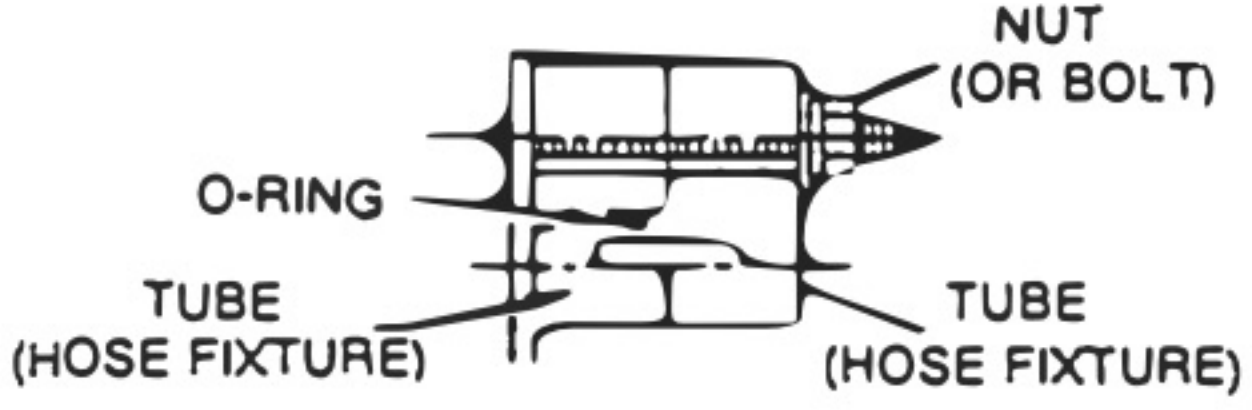

[TIGHTENING TORQUE TABLE (FOR PIPES)]

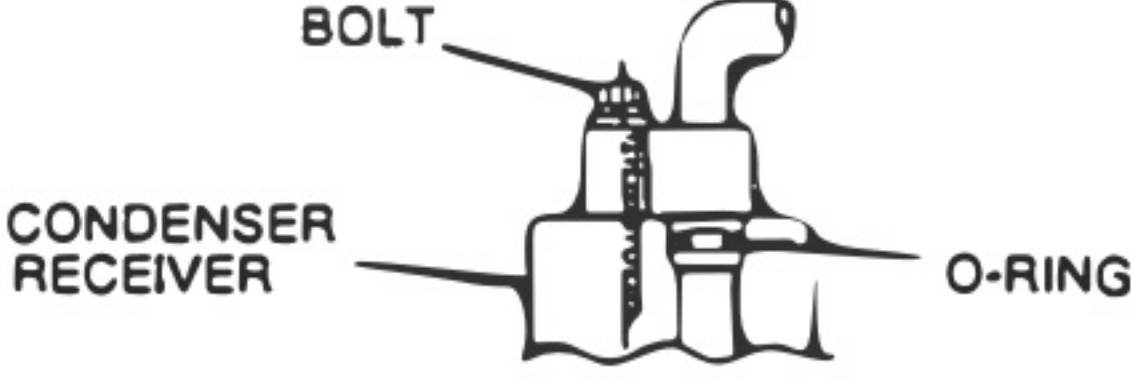
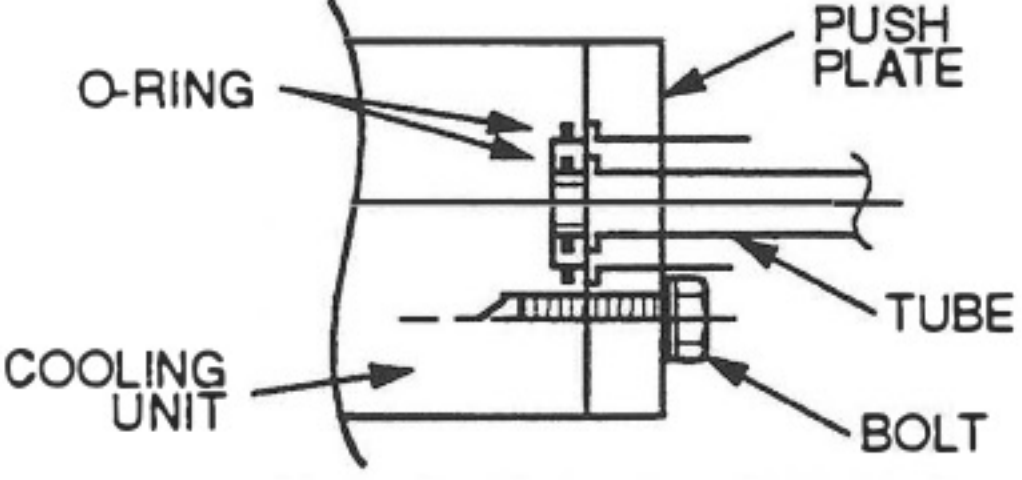
| STRUCTURE   | TUBE SIZE                                      | TIGHTENING TORQUE  |  |   |
|---|--|--|--|---|
|   |  | N•m  | kgf•cm   | ft•lbf  |
| <p>&lt;GENERAL PIPING (UNION TYPE)&gt;</p>   | <p>1/4"</p> <p>φ 8</p> <p>1/2"</p> <p>5/8"</p> | <p>7.8±1.0</p> <p>13.7±1.0</p> <p>22.5±2.0</p> <p>32.3±2.0</p> | <p>80±10</p> <p>140±10</p> <p>230±20</p> <p>330±20</p> | <p>5.8±0.7</p> <p>9.8±1.0</p> <p>16.2±1.7</p> <p>23.4±1.7</p> |
| <p>&lt;GENERAL PIPING (BOLT, NUT TYPE)&gt;</p>   | <p>BOLT &amp; NUT SIZE</p>                     | <p>N•m</p>   | <p>kgf•cm</p>  | <p>ft•lbf</p>   |
| <p>&lt;COMPRESSOR&gt;</p>    |  | <p>9.8±2.0</p>   | <p>100±20</p>  | <p>7.2±1.3</p>  |
| <p>&lt;CONDENSER (EXCEPT MF TYPE) &gt;<br/>&lt;COOLING UNIT&gt;(EXCEPT ONE BOLT PLATE TYPE)</p>  | <p>M6</p>                                      |  |  |   |
| <p>&lt;CONDENSER (MF TYPE)&gt;<br/>&lt;RECEIVER&gt;</p>    |  | <p>5.4±1.0</p>   | <p>55±10</p>   | <p>4.0±0.7</p>  |
| <p>&lt;COOLING UNIT &gt;<br/>(ONE BOLT PLATE TYPE)</p>   |  |  |  |   |

## 1-4 PRECAUTIONS FOR SAFETY INSTALLATION

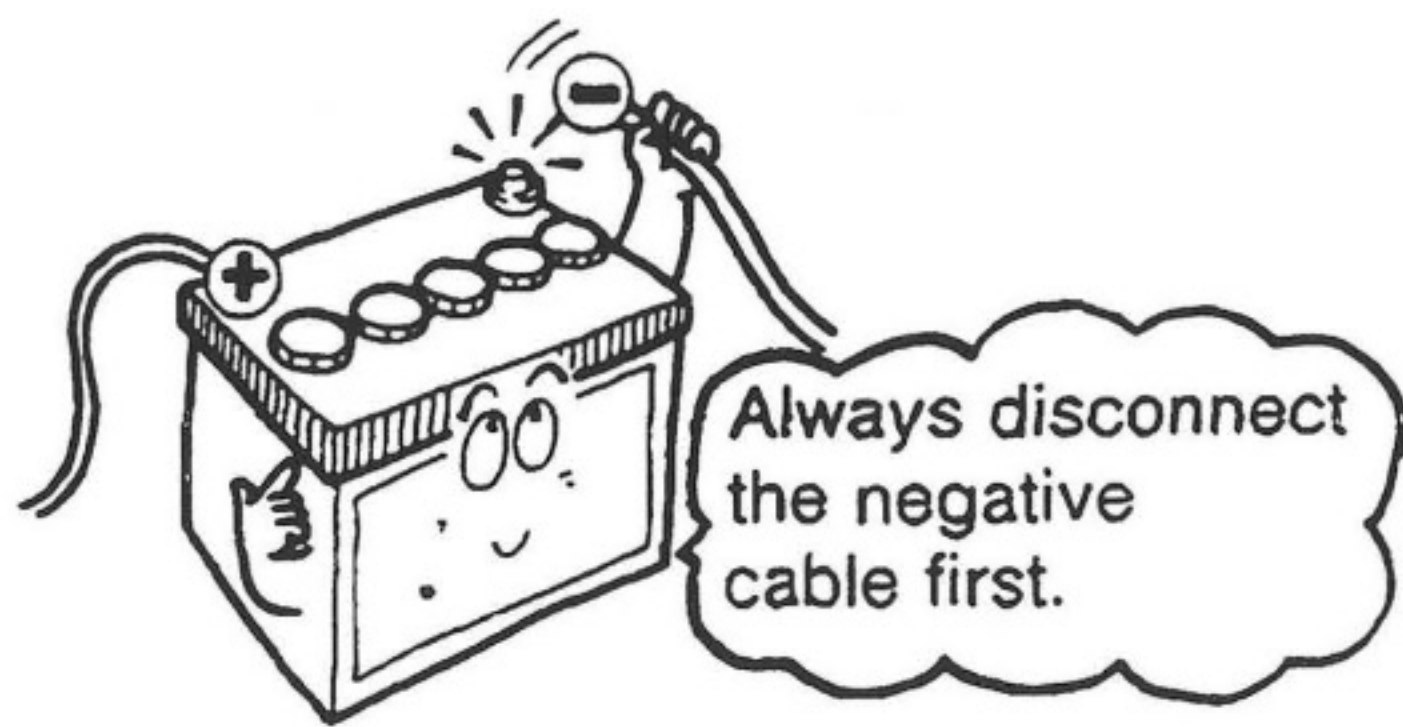

- (1) Do not proceed with the installation until the battery cables have been disconnected or a short-circuit may result.

### NOTE

1. Always disconnect the **NEGATIVE CABLES** first.
2. When **RECONNECTING** the cables, make sure to connect the positive cable to the positive battery terminal and the negative cable to the negative battery terminal.



- (2) Do not smoke or expose open flame near the vehicle during installation.

### NOTE

Pay special attention when working on the fuel system.

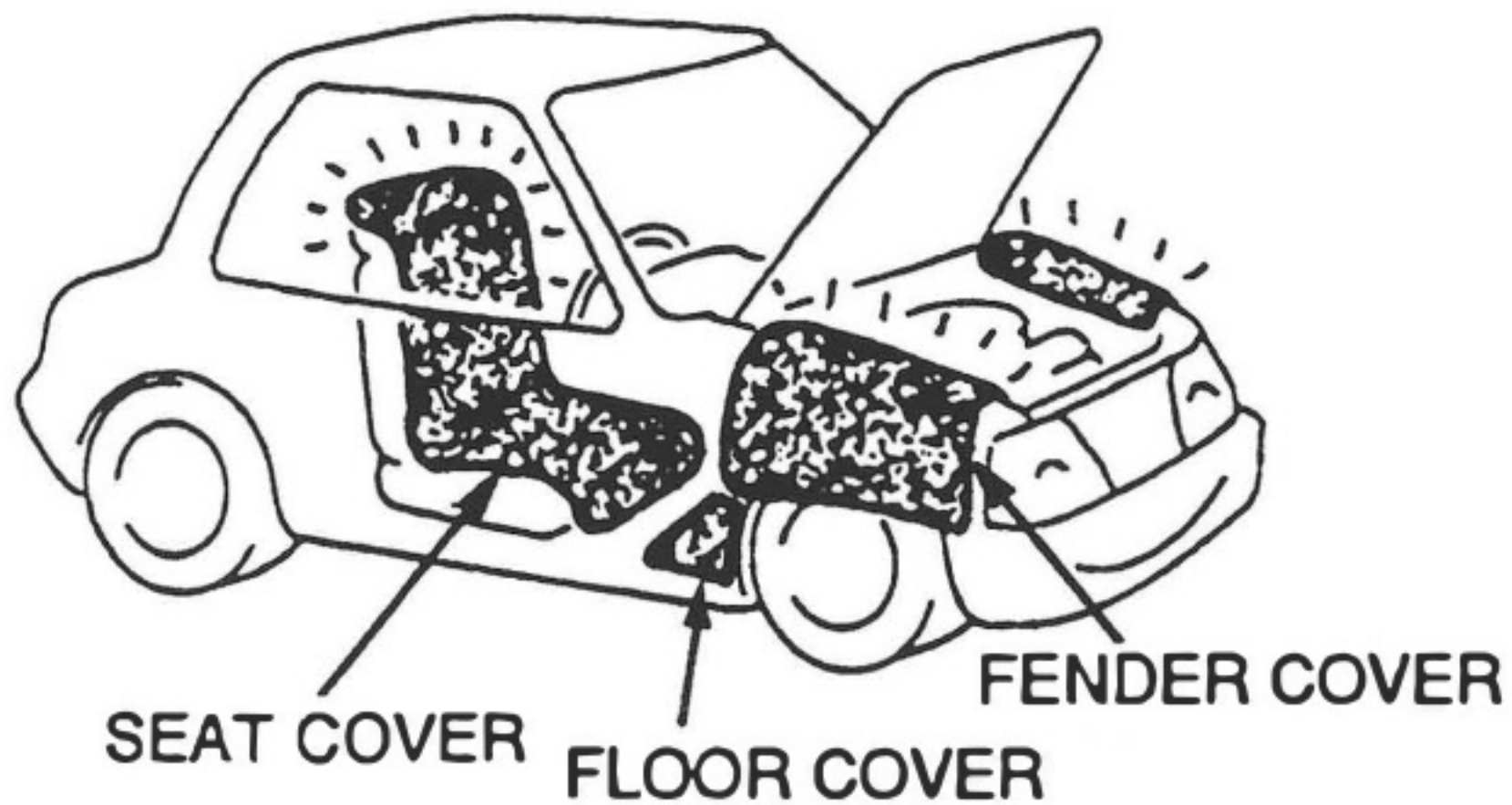

- (3) Use protective covers to avoid damage to the vehicle and the air conditioning parts.

- Seat covers
- Fender covers
- Floor covers

TORQUE WRENCH

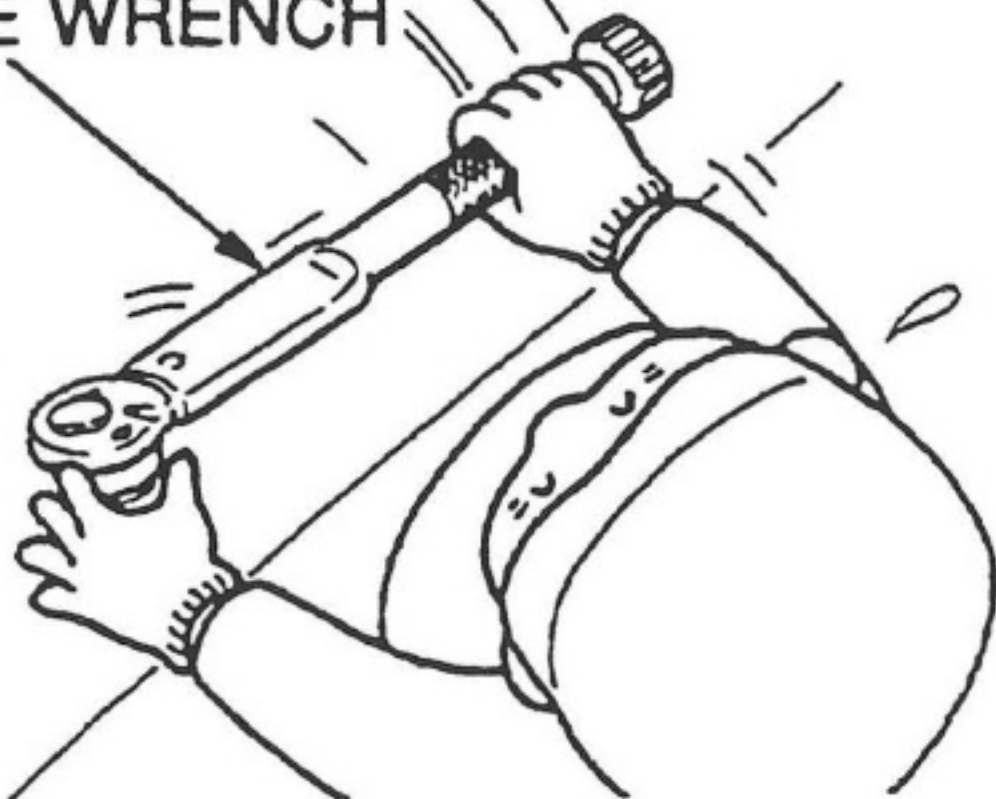

- (4) The bolts, nuts and fittings where specified must be torqued to proper specification. If torque is not specified, refer to **TIGHTENING TORQUE TABLE** on page 2.

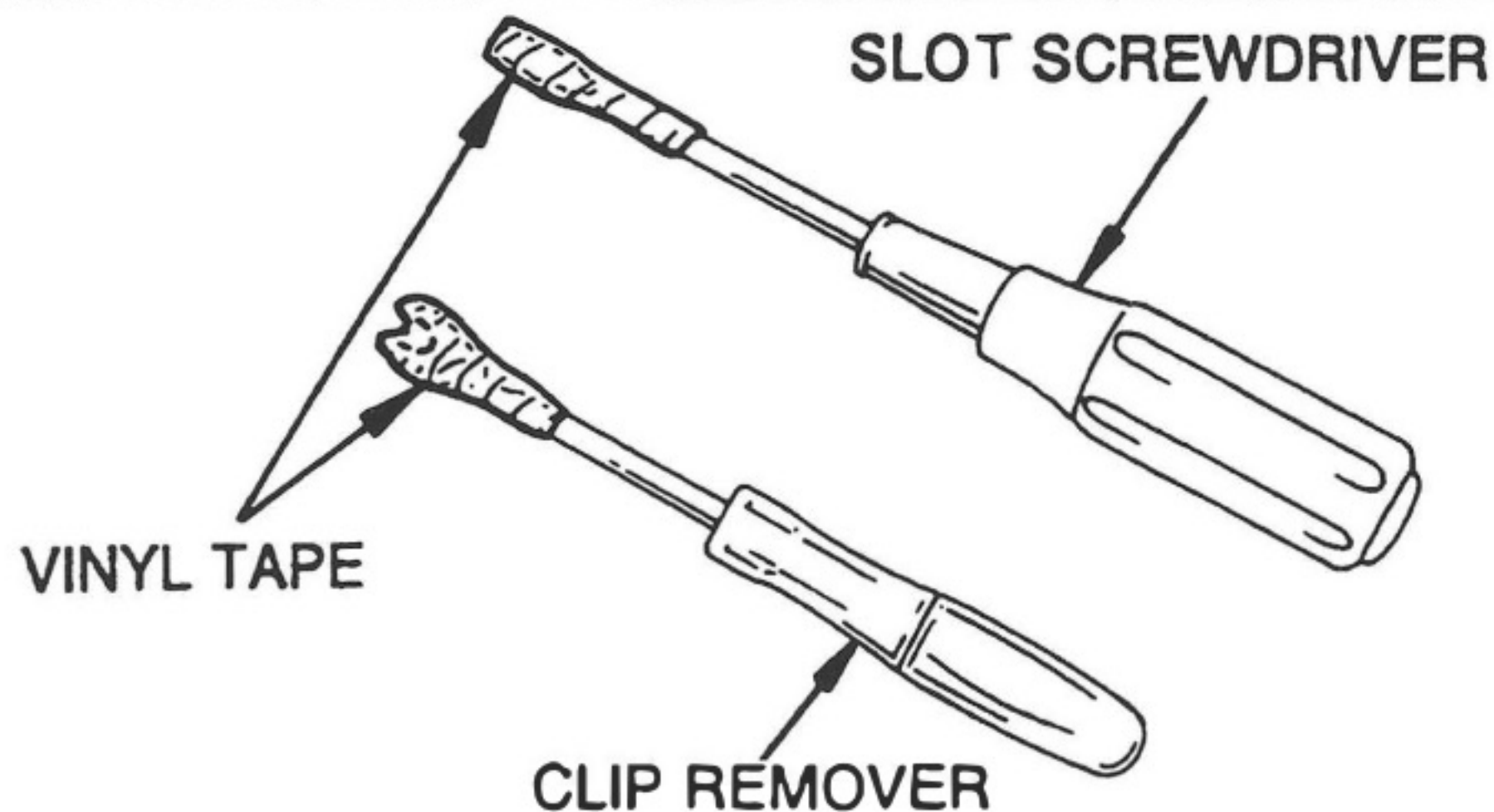

- (5) Take care not to scratch any part of the vehicle. Bind the tips of tools (clip remover, slot screwdriver etc.) with a piece of vinyl tape to prevent damage to parts of the vehicle.

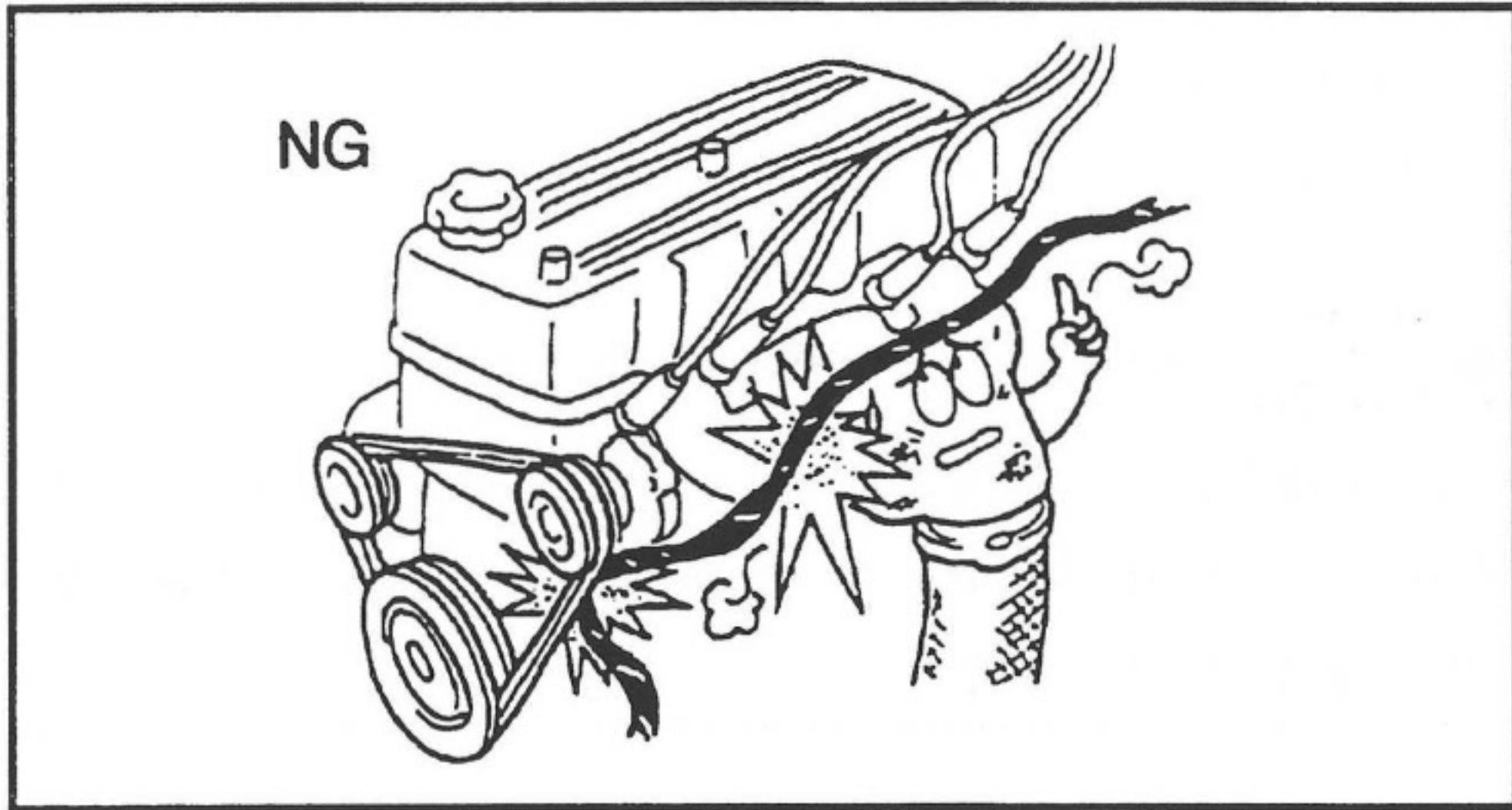

- (6) When installing the A/C harnesses, route properly avoiding interference with surrounding parts.

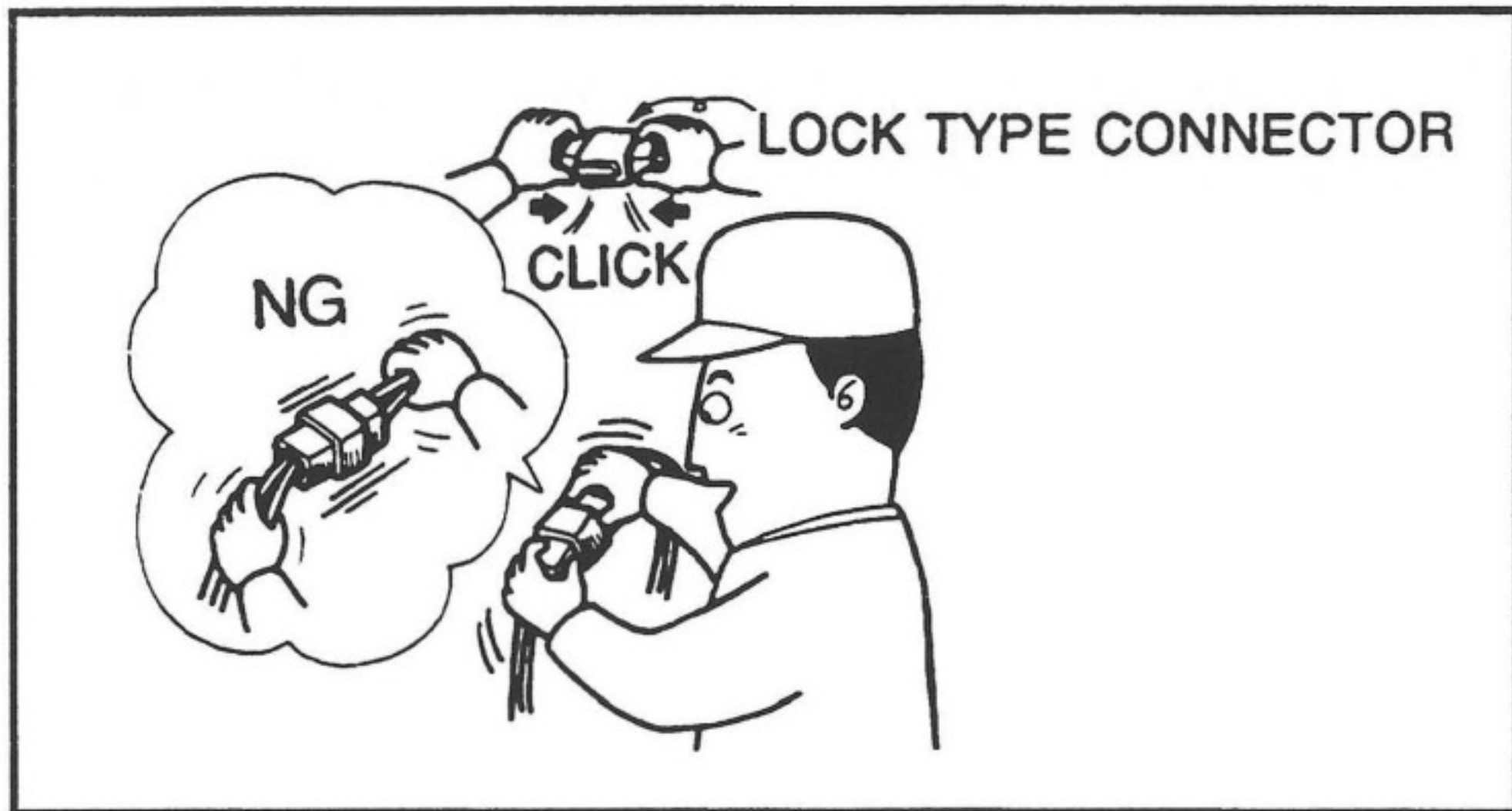

- (7) Do not pull on vehicle wires and/or wire harnesses. To uncouple electrical connectors, pull only on the connector itself to avoid damage.

**NOTE**

*In case of lock type connectors, make sure that the connectors are unlocked before disconnecting. When re-connecting the connectors, insert them until a clicking noise is heard. After they are connected, hold and pull them gently to check that they are connected properly.*

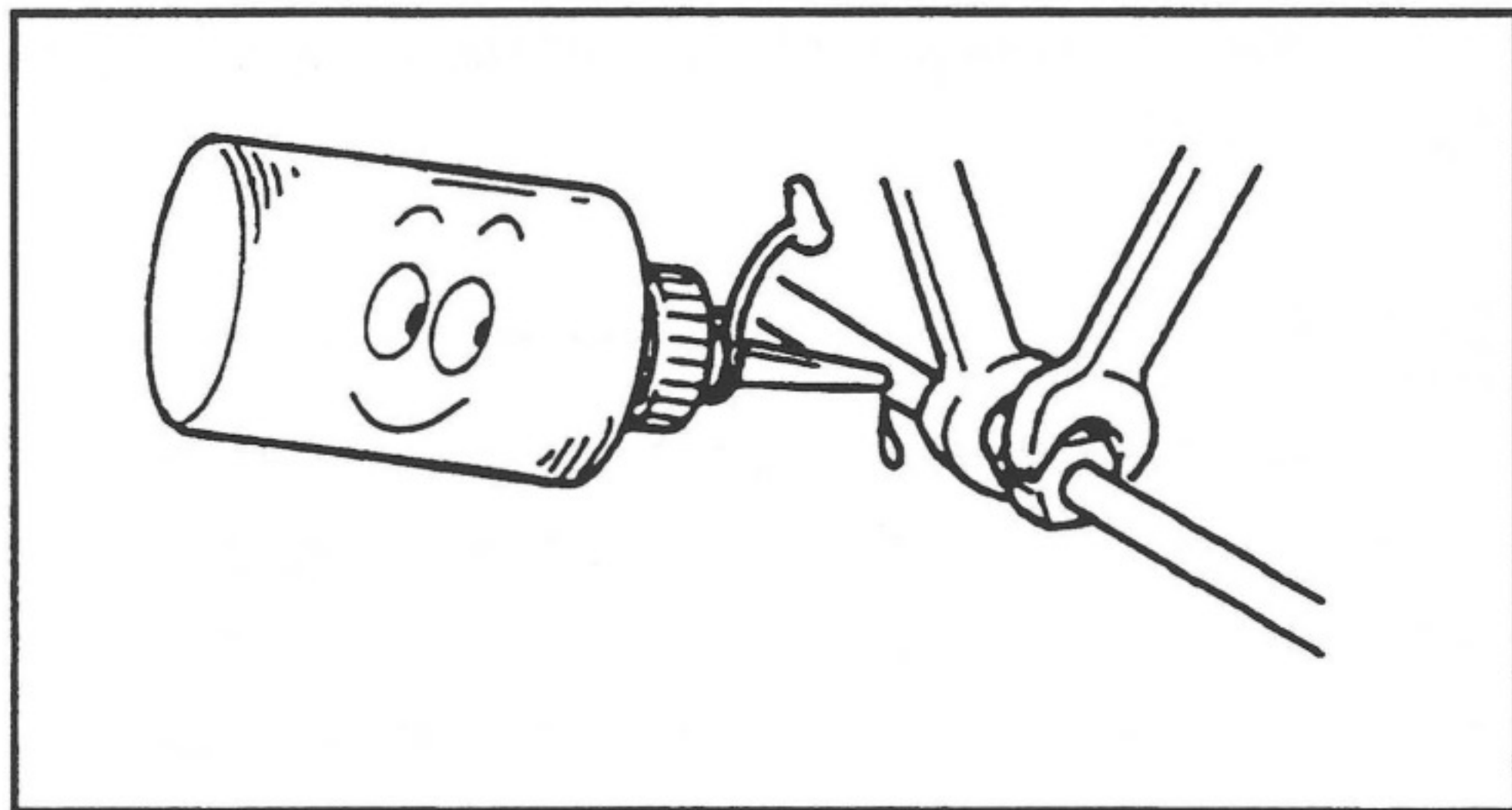

- (8) Before making any hose and tube connections, apply a few drops of compressor oil to the seat of O-ring to avoid refrigerant leakage.

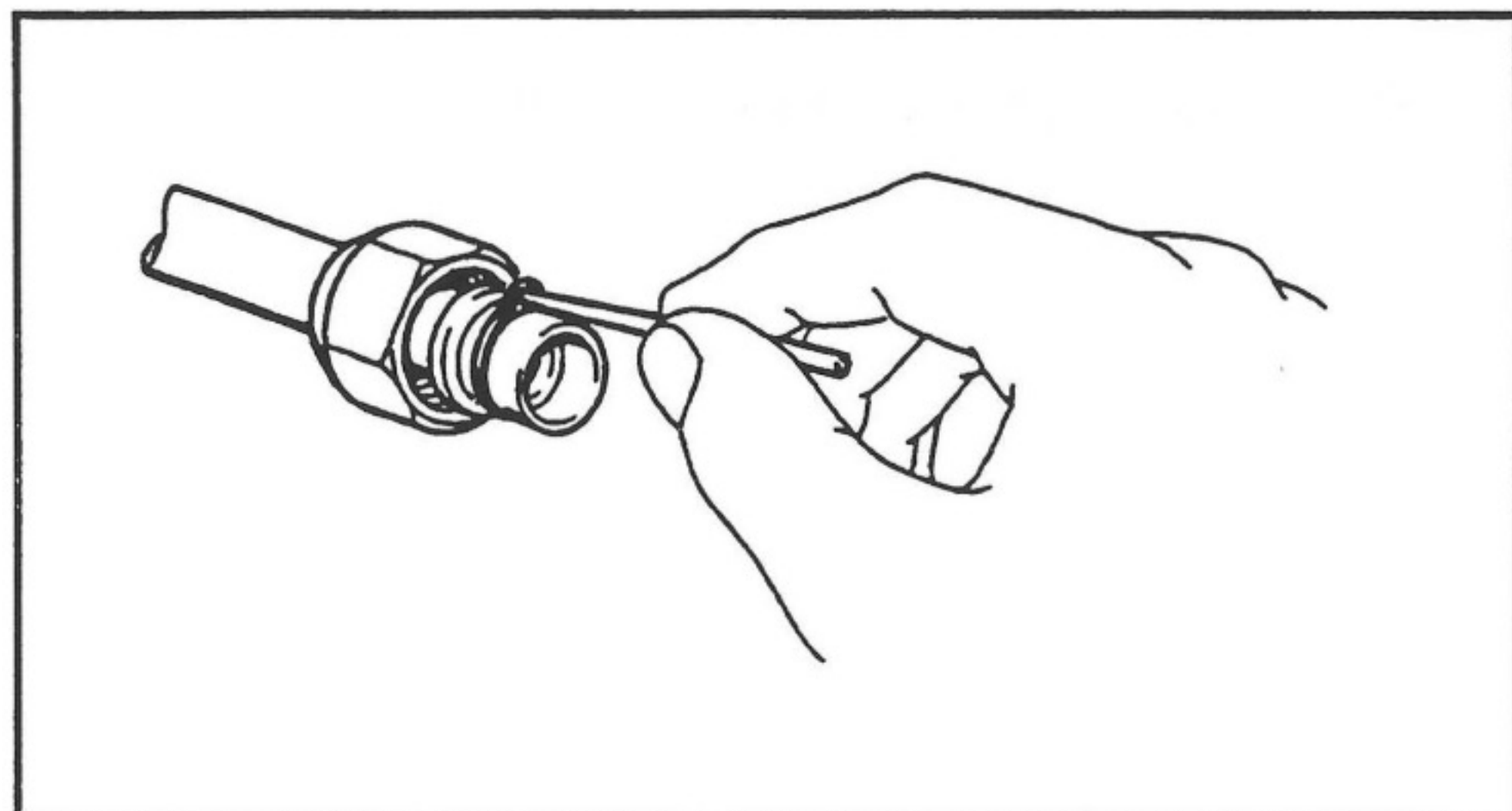

- (9) When removing an O-ring from a tube, use a wooden or nylon awl to prevent damaging the tube.

**NOTE**

*Always replace the existing O-rings with new ones specified for refrigerant HFC-134a.*

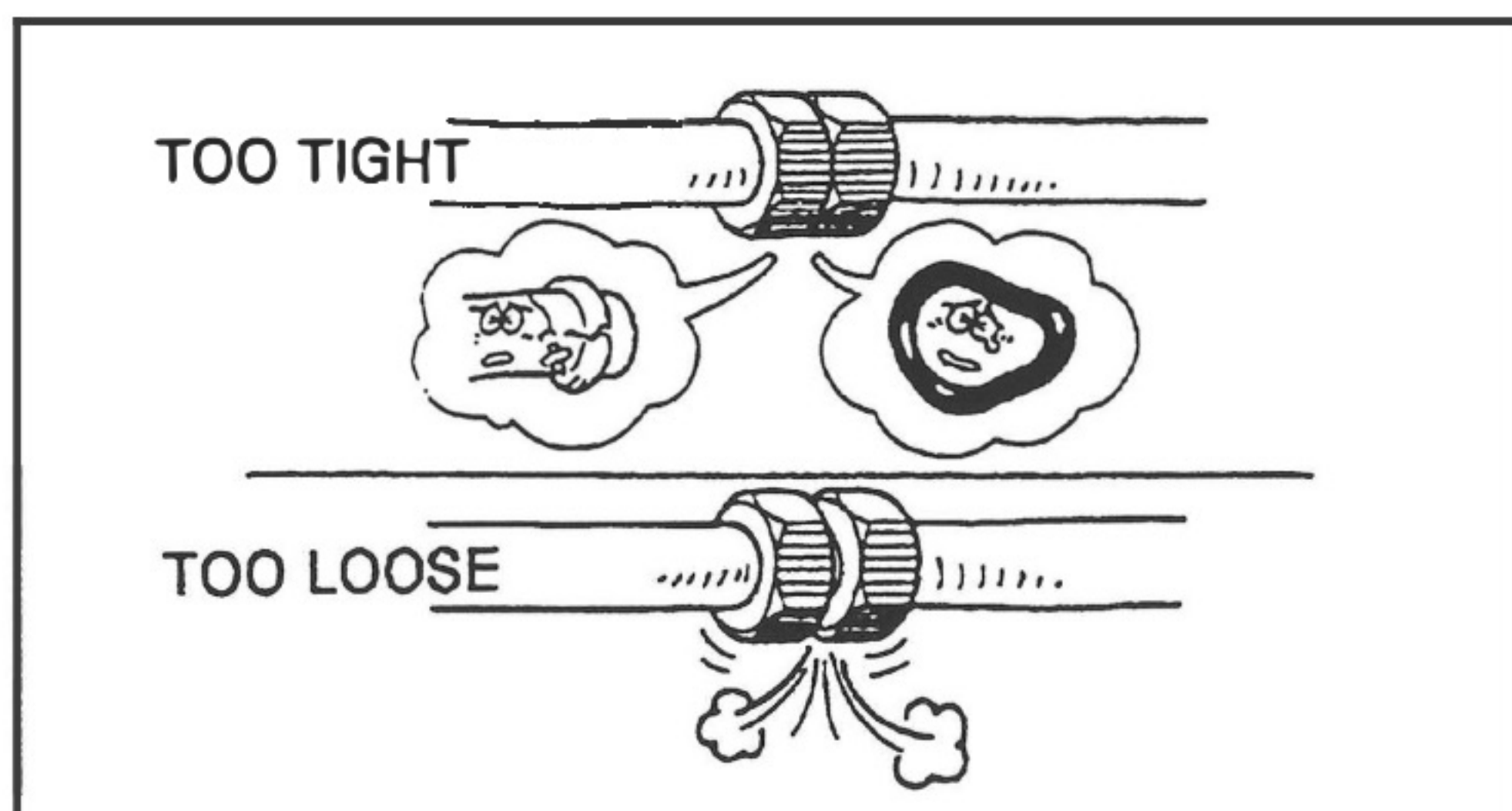

- (10) When tightening or loosening fittings, use two wrenches to prevent the tubes from twisting. After loosening the fittings, tighten them with specified torque.

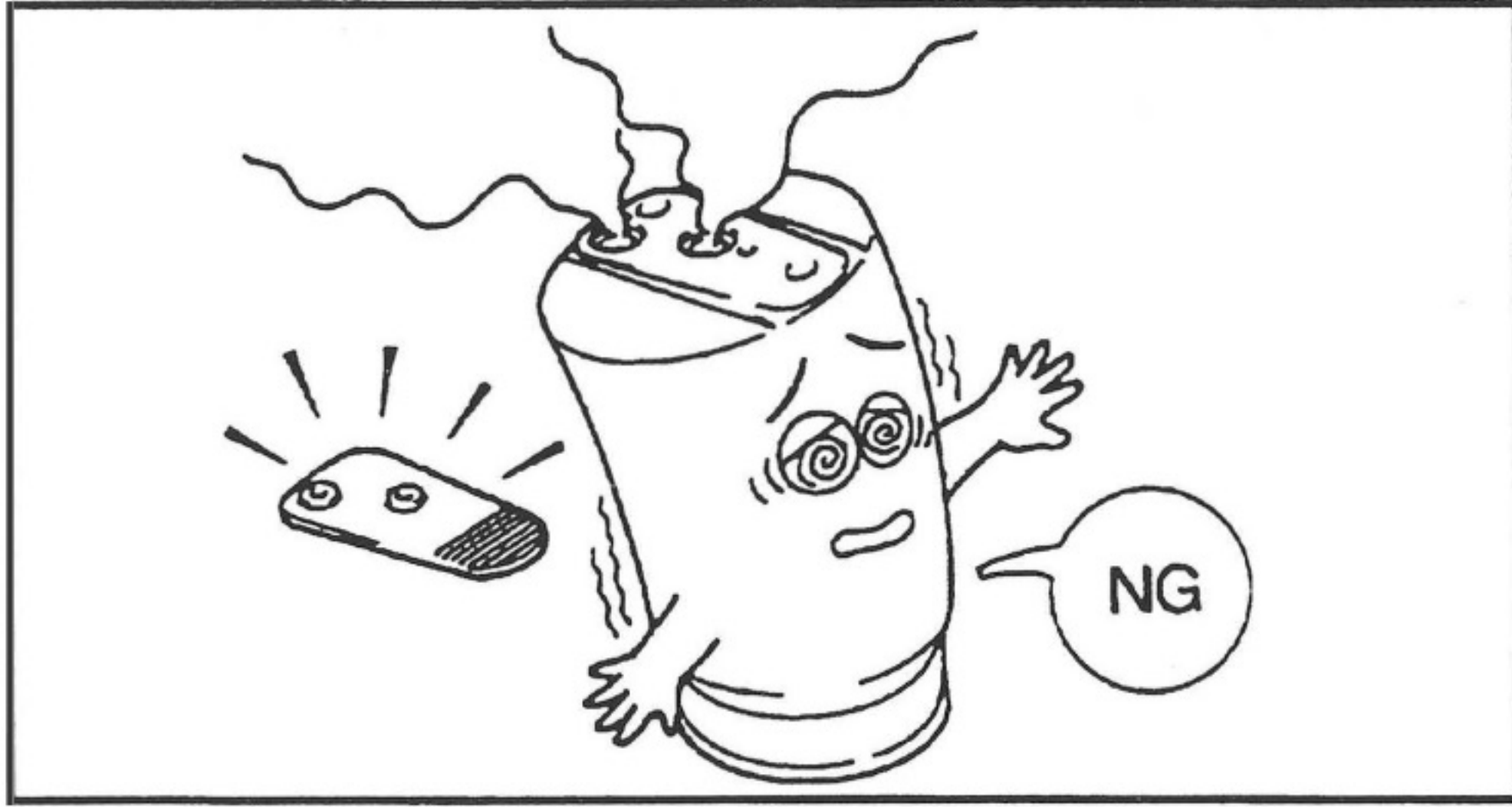

(11) Do not remove protective caps from fittings until each component is ready for connection.

**NOTE**

*If the receiver is left uncapped for a long time, the desiccant inside the receiver may absorb moisture, causing damage to the air conditioning.*



(12) When handling refrigerant, always wear proper eye protection and do not allow it to come in contact with skin.

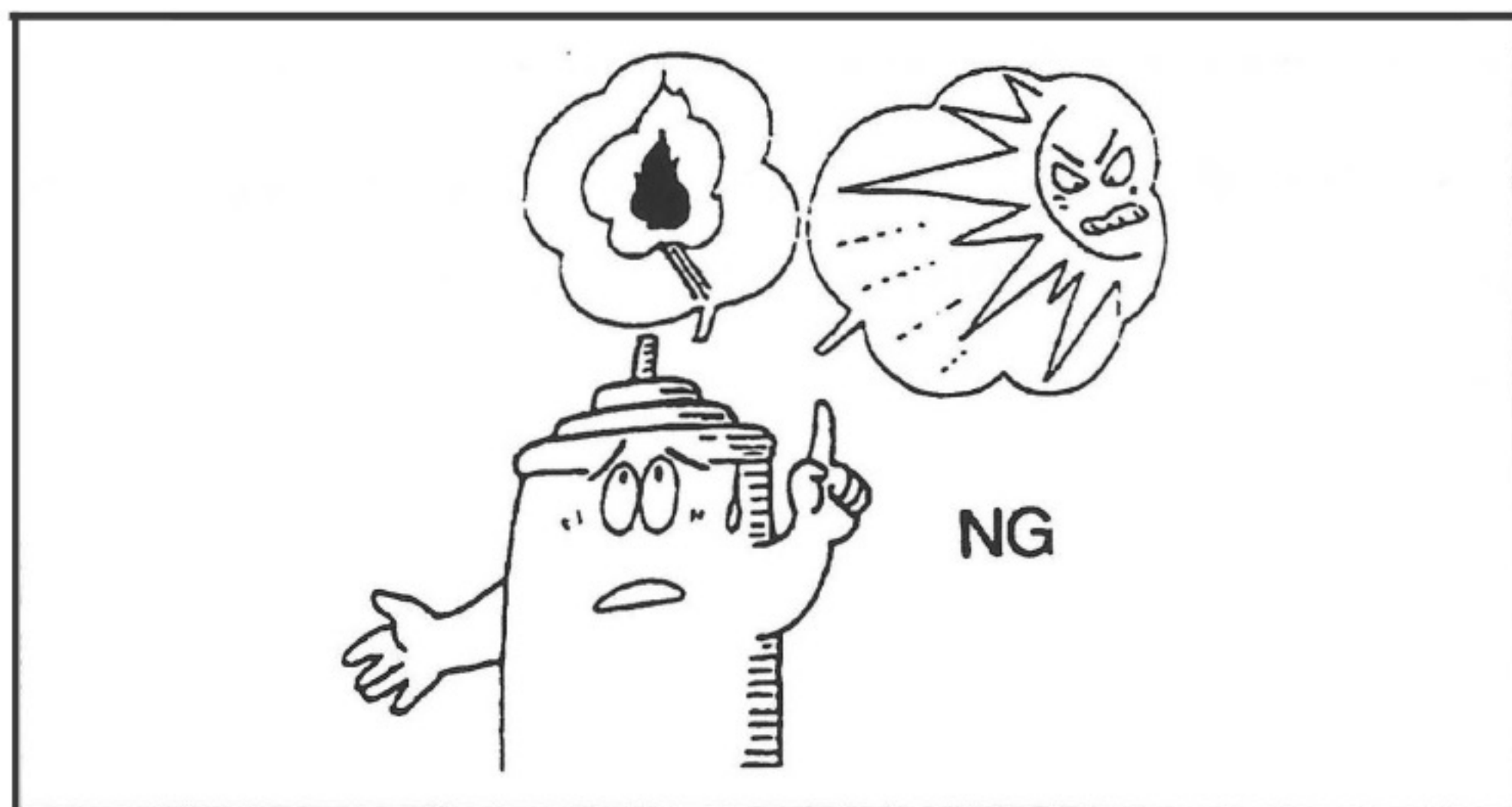

(13) Always keep the refrigerant container (service drum) below 40°C (104 °F).

**NOTE**

*Do not store the refrigerant container in an area where it can be exposed to direct sunlight, near a source of fire, or an area such as the inside of a car (the trunk etc.), where the temperature may become high. Store the container in a dark place with low-humidity.*

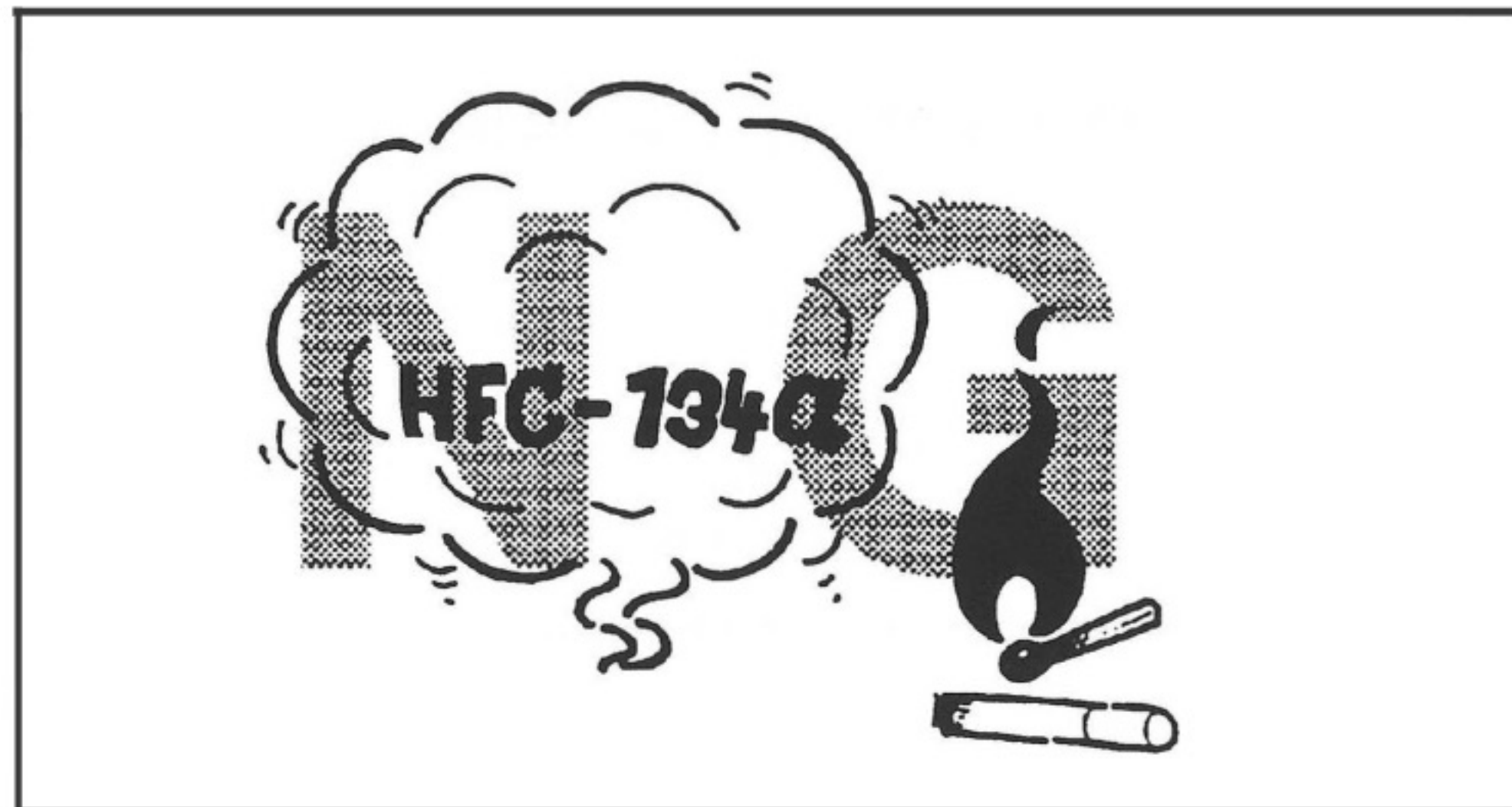

(14) Do not expose refrigerant to an open flame.



(15) Do not drop compressor oil (ND-OIL 8, 9) onto the vehicle surface. It causes the discoloration of the vehicle's body surface, or deterioration of the acrylic or ABS plastic components.

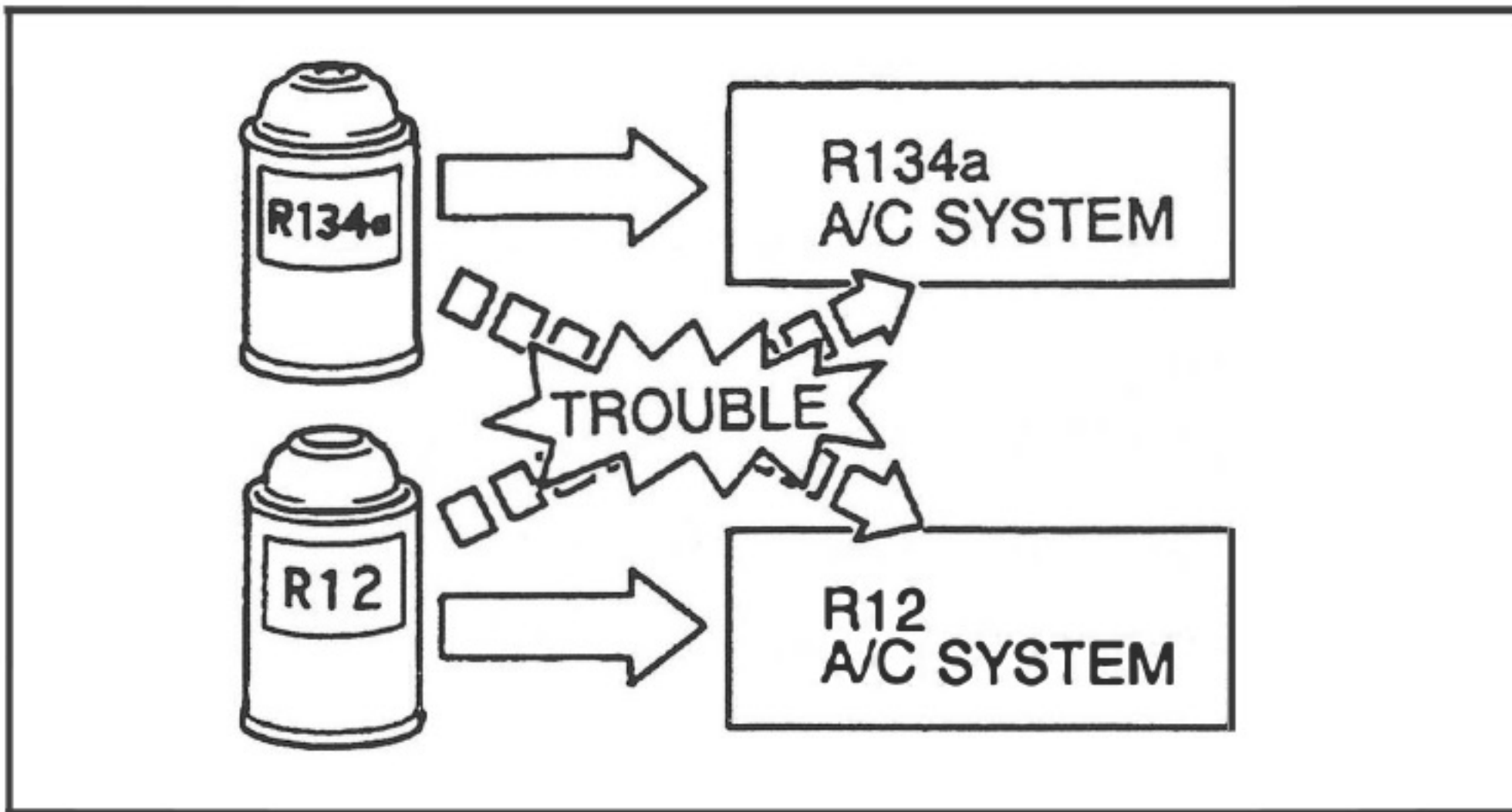

(16) Use the refrigerant HFC-134a (R134a).

**NOTE**

The very different characteristics of refrigerants HFC-134a (R134a) and CFC-12 (R12) have determined the design of their respective air conditioning systems. Under no circumstances allow CFC-12 (R12) to enter an HFC-134a (R134a) system, or vice versa, because serious damage could occur.



(17) Use the correct compressor oil.

**NOTE**

Compressor oil used in pre 1993 vehicles CFC-12 (R12) air conditioning systems cannot be used in HFC-134a (R134a) air conditioning systems.

- For a swash plate type compressor : ND-OIL 8
- For a through vane type compressor: ND-OIL 9

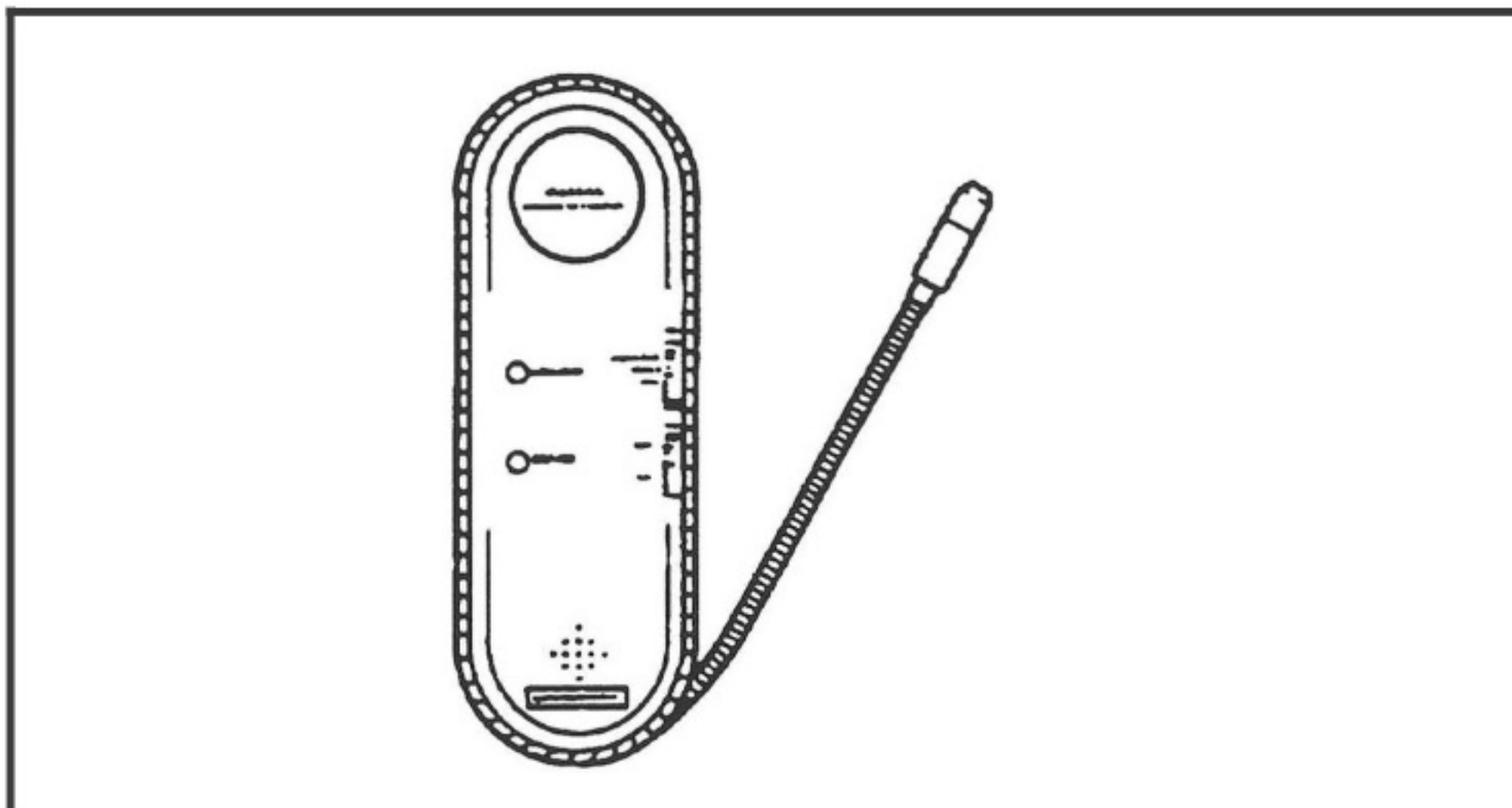

(18) Use HFC-134a (R134a) gas leak detector.

**NOTE**

The CFC-12 (R12) leak detector is not sensitive enough to detect HFC-134a (R134a).

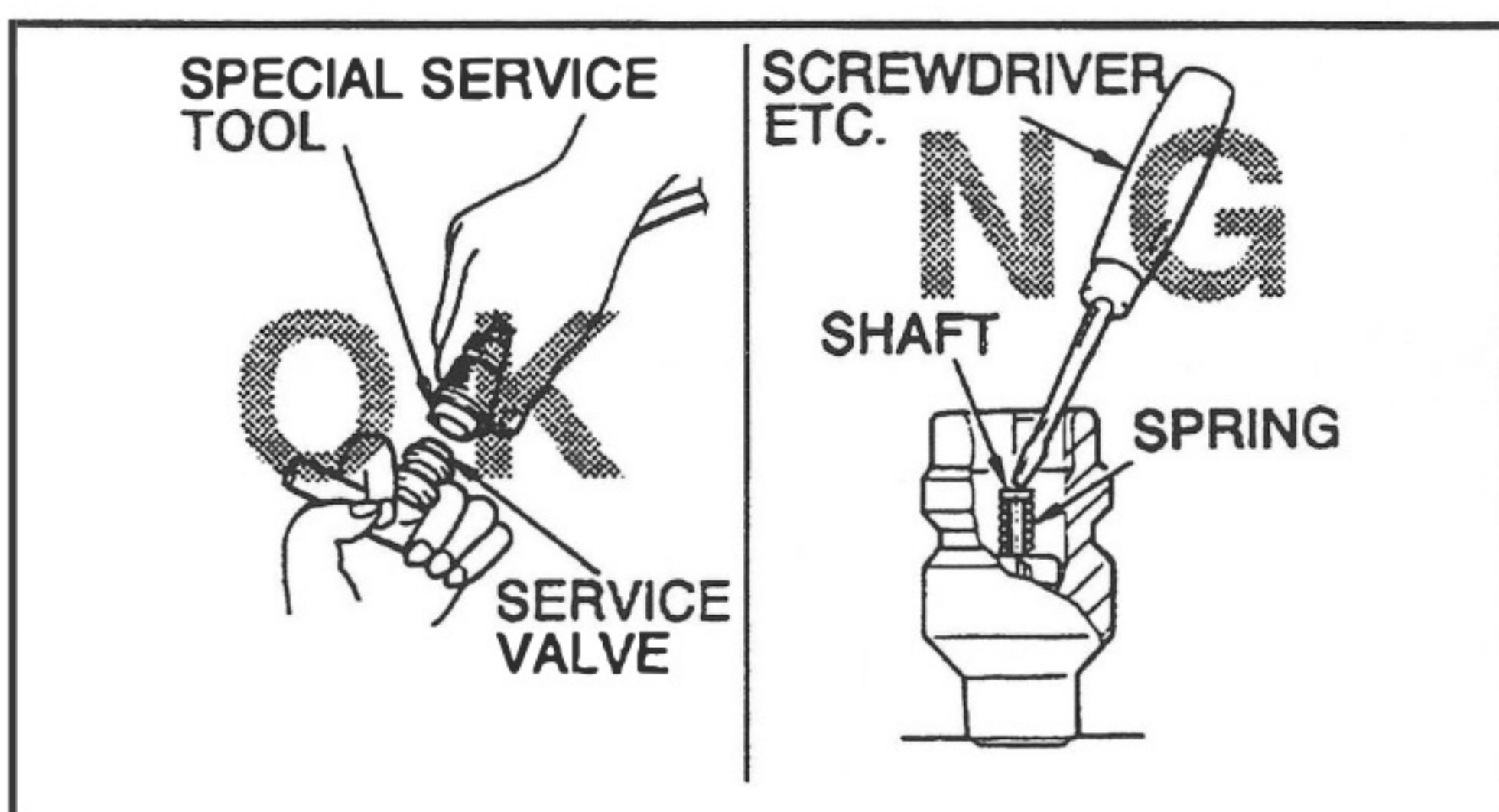

(19) When recovering refrigerant, use the necessary special service tools.

**NOTE**

1. Support the service valve by hand to prevent the tube from bending when connecting the charging hose.
2. Using a general tool like a screwdriver may cause refrigerant leak by damaging the service valves.

(20) Use manifold gauges for HFC-134a (R134a).

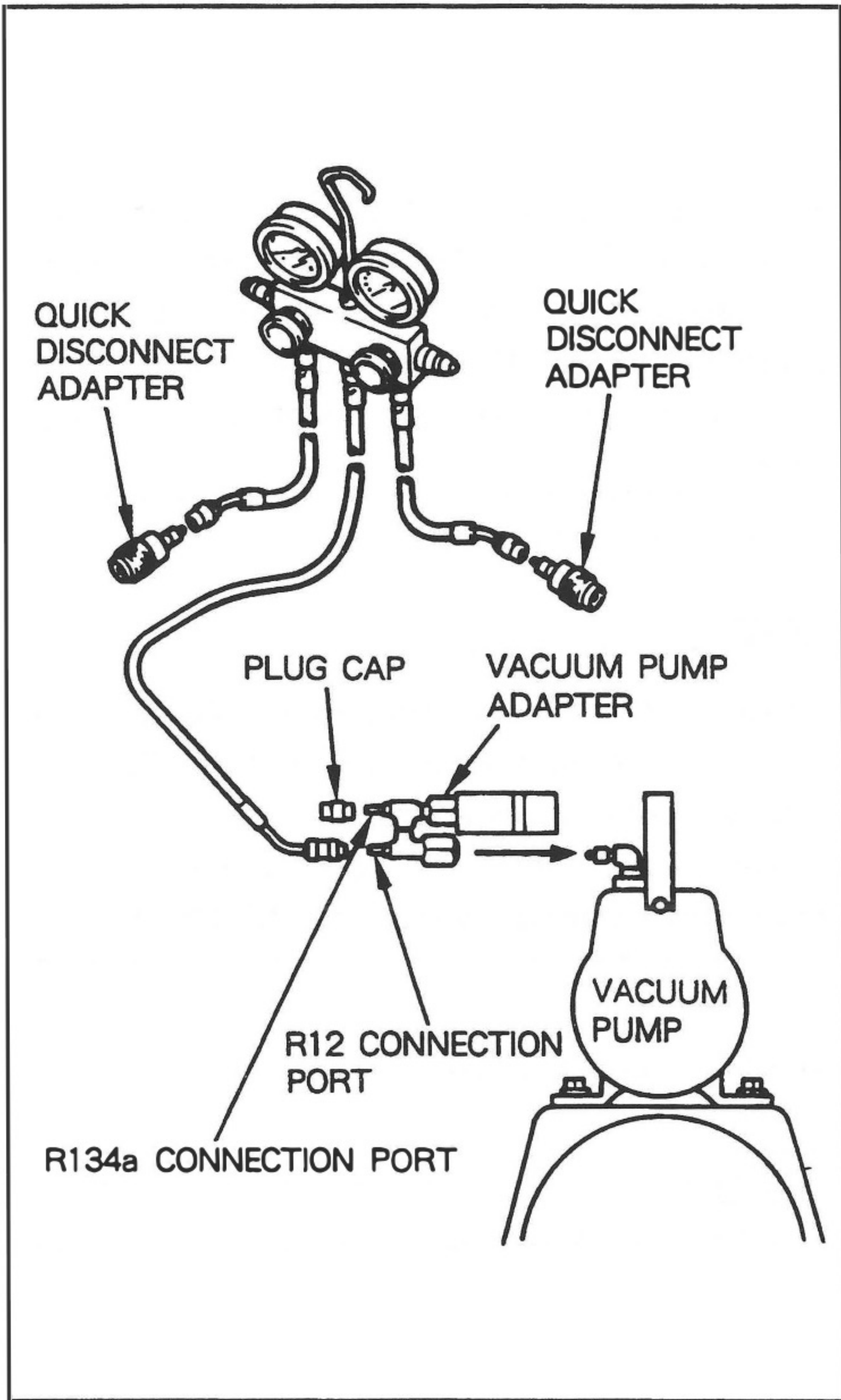

**NOTE**

1. *Manifold gauges*

*Always use HFC-134a (R134a) dedicated manifold gauges to prevent CFC-12 (R12) and CFC-12 (R12) compressor oil contaminating the HFC-134a (R134a) system.*

2. *Vacuum pump adapter*

(1) *By connecting a vacuum pump adapter, the vacuum pump can be used for both HFC-134a (R134a) and CFC-12 (R12) air conditioning systems.*

(2) *Be sure to turn off the manifold gauge valve immediately after evacuating the system, then switch off the vacuum pump. If this order is reversed, the line will be temporarily open to atmosphere.*

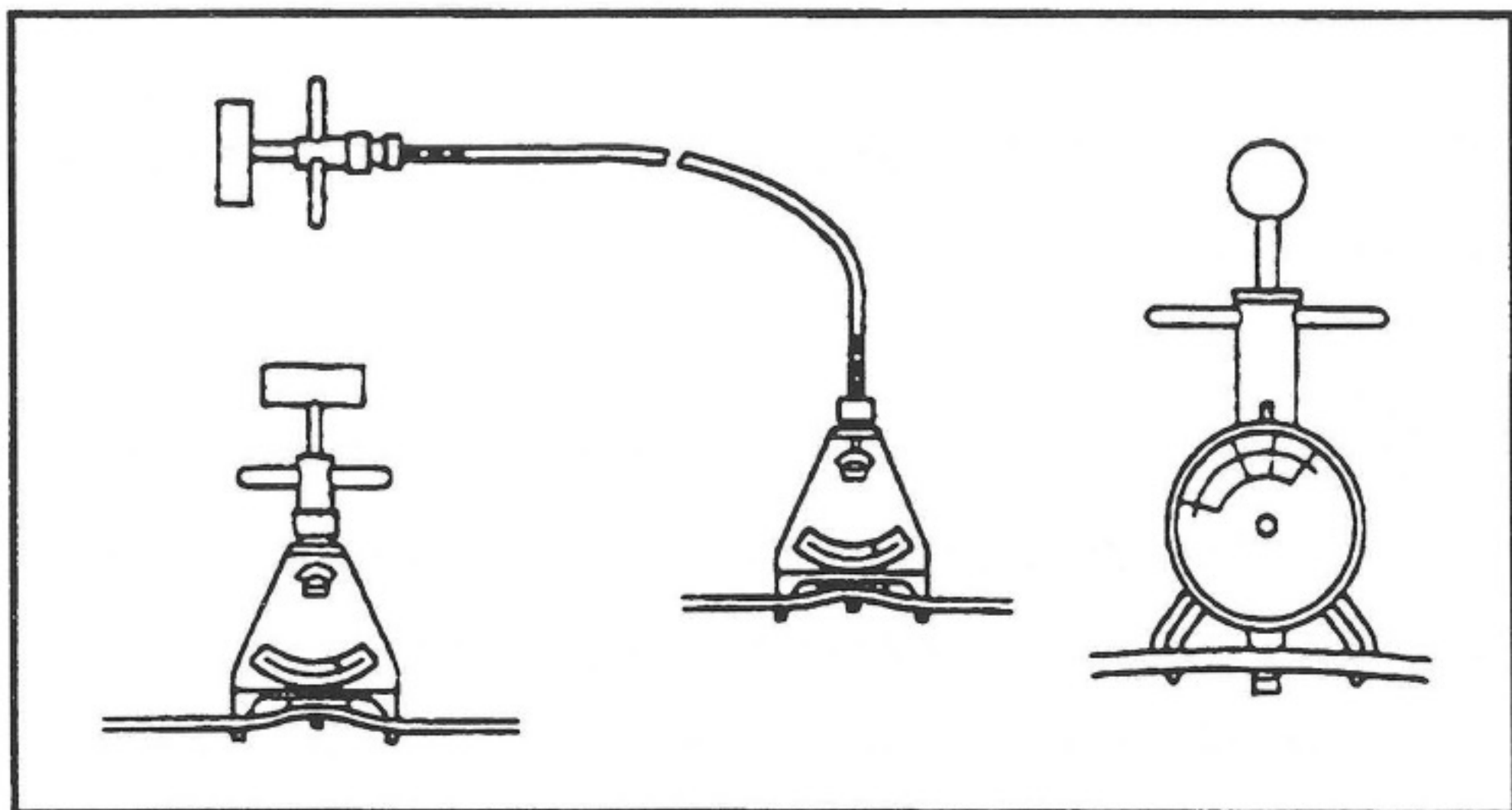

(21) After installing the drive belt, check the belt tension using a belt tension gauge DENSO BTG-20 or BORROUGHS BT-33-73F.

**NOTE**

1. *The belt tension must be measured between the specified pulleys as indicated in the installation manual.*

2. *A "New belt" refers to a belt which has been used for less than 5 minutes of operation.*

*A "Used belt" refers to a belt which has been used for more than 5 minutes of operation.*

3. *The drive belt requires accurate tension adjustment ; a slack belt is likely to cause the belt to whine, while excessive tension may result in damage to the bearings or the idle pulley bracket.*

4. *After installing the drive belt, make sure it is properly seated in the grooves of the pulley.*

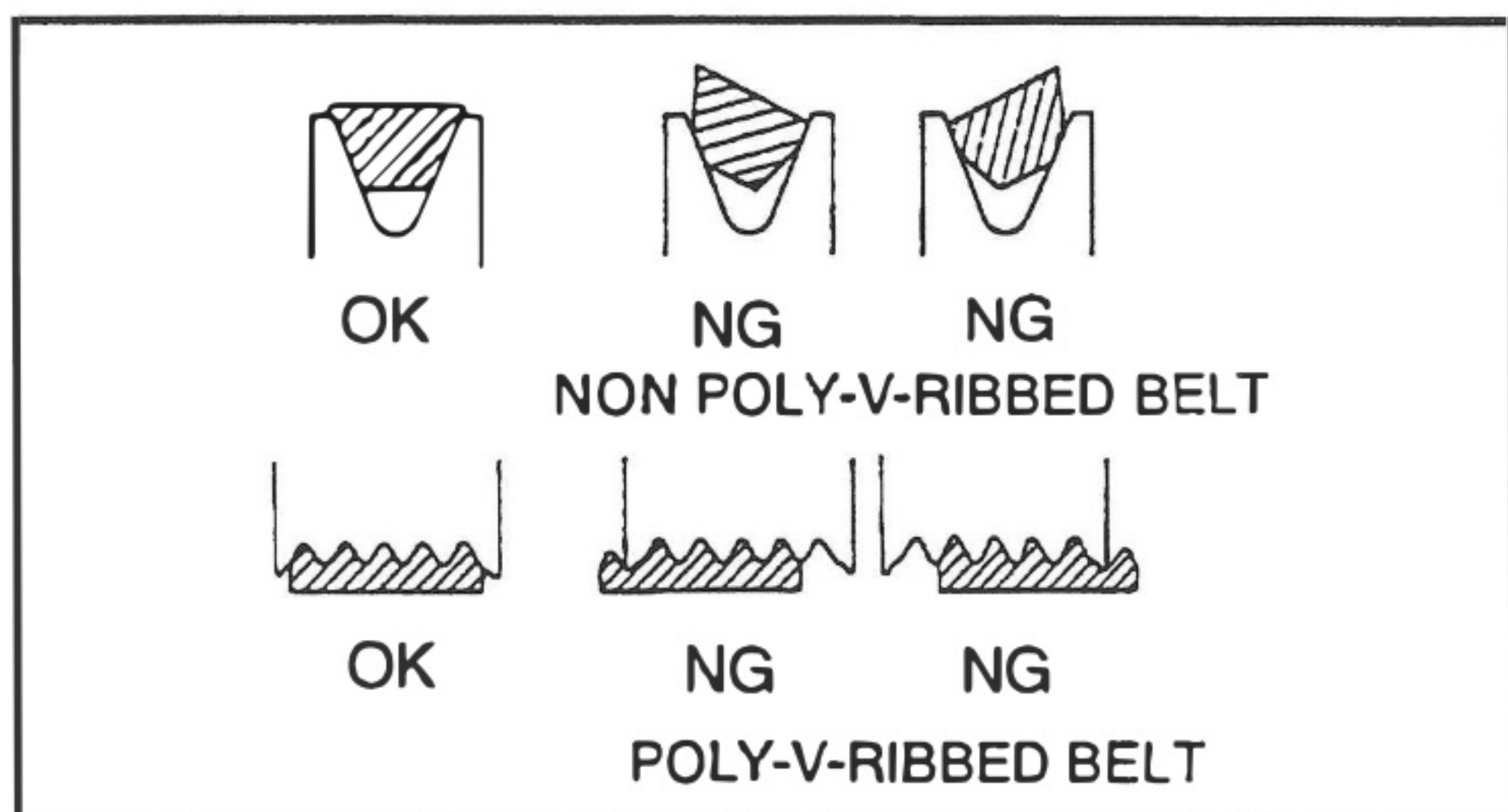

## 1-5 PIPE JOINT PRECAUTIONS

(1) Common to all pipe joints

(a) After connecting or mating pipes, tighten bolts or nuts. See illustration below for correct mating.

### NOTE

Incomplete mating (pipes that are joined in a slanted position) often causes pinched O-rings, or scratches on the seal surfaces.

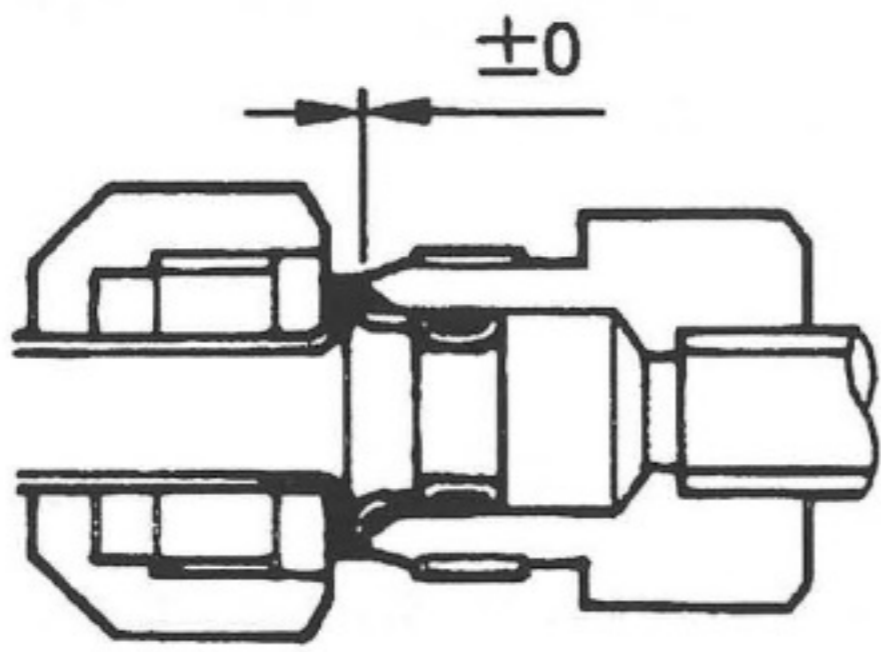
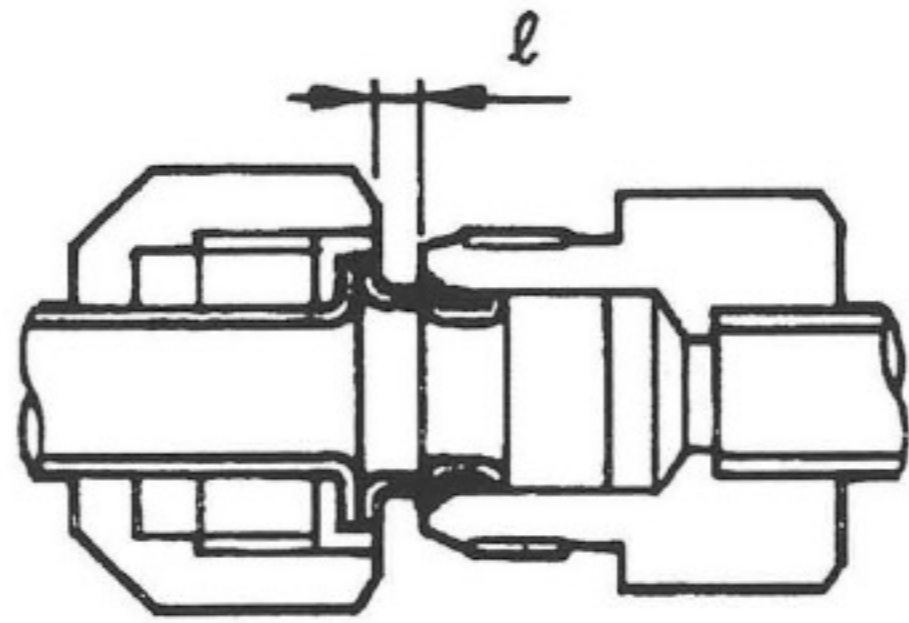
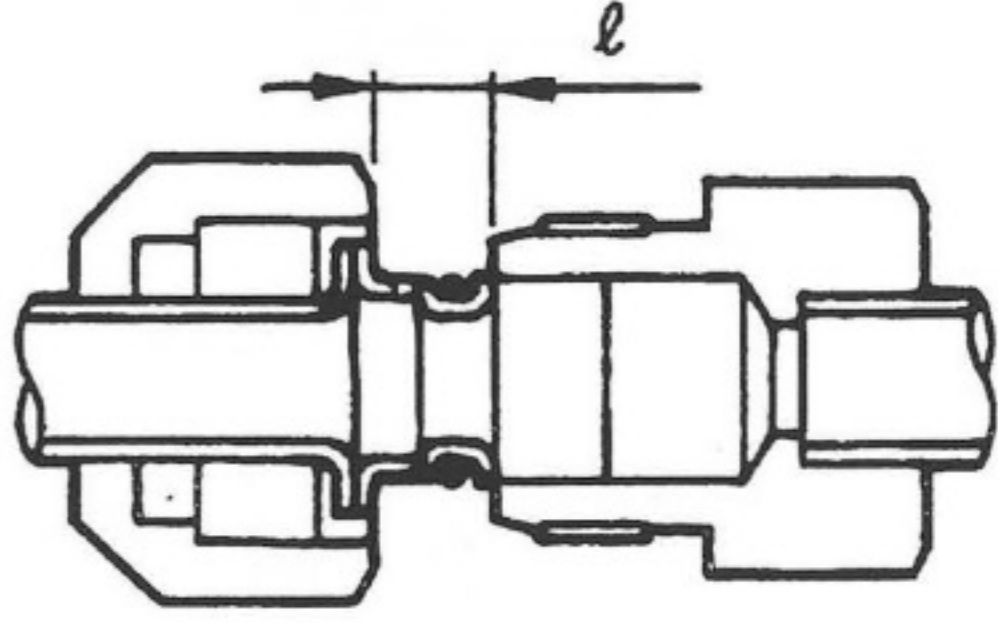
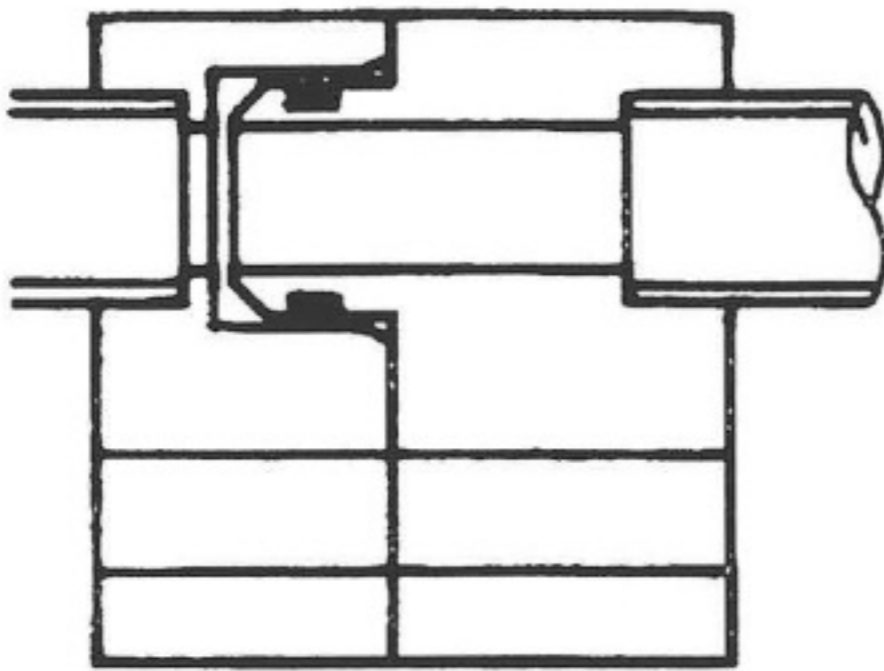
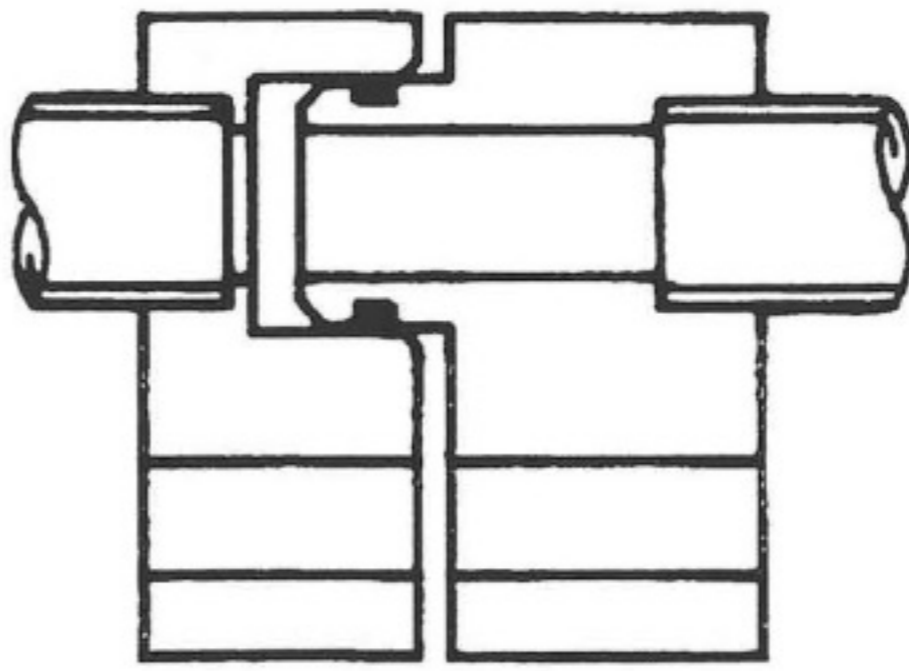
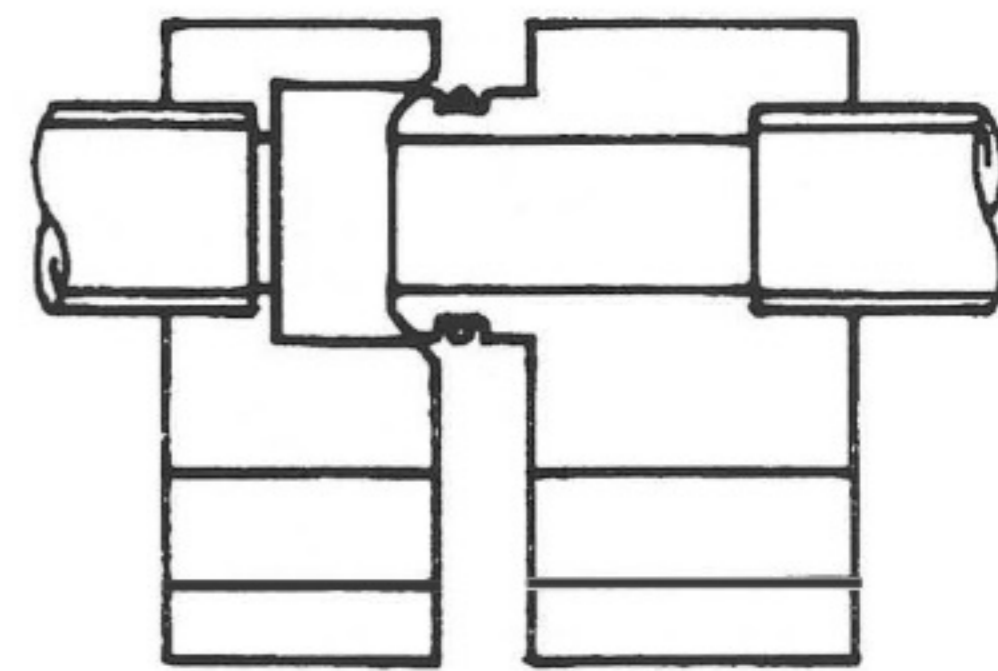
|               | Complete Mating<br>(Insert a male part into a female part.)                         | Incomplete Mating   |   |
|---------------|---|---|---|
| Nut union     |   |   |   |
| Determination | OK  | NG  | NG  |
| Block joint   |  |  |  |
| Determination | OK  | NG  | NG  |

(b) If it is difficult to mate the joints, apply the specified compressor oil\* to an O-ring before installing it.

\*ND-8 : 10P-type, 7SB, scroll

ND-9 : TV-type

### !CAUTION

1. Avoid applying oil in areas with acrylic resin or ABS plastic as it causes environmental stress cracking to these resins.
2. Prevent foreign materials from contaminating the oil.

(c) Make sure the O-ring is installed correctly before mating the joints.

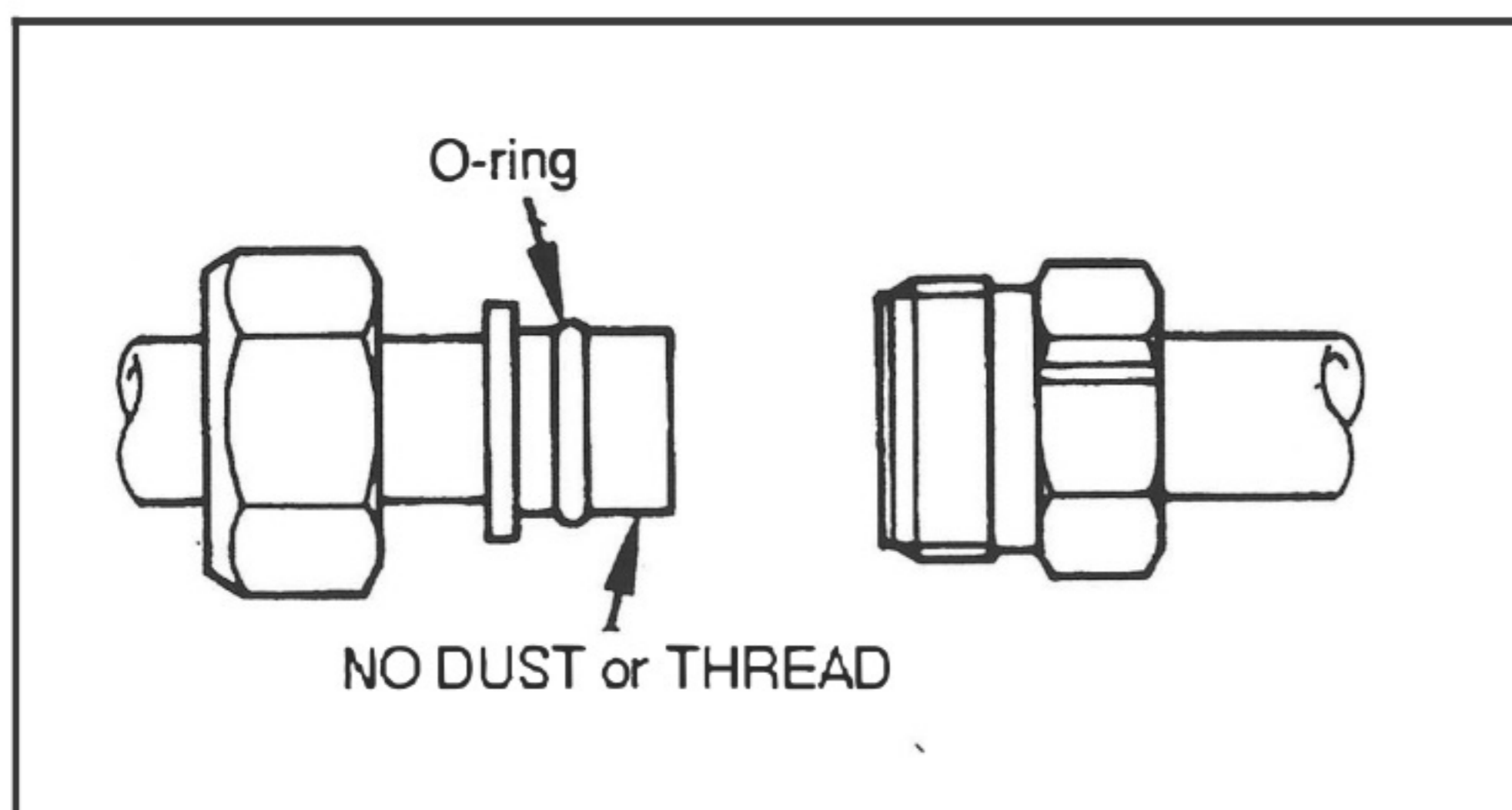

(d) Make sure the O-ring is free of dust.

### NOTE

Do not touch the O-ring with gloves on. Most gloves are coated with a powder.

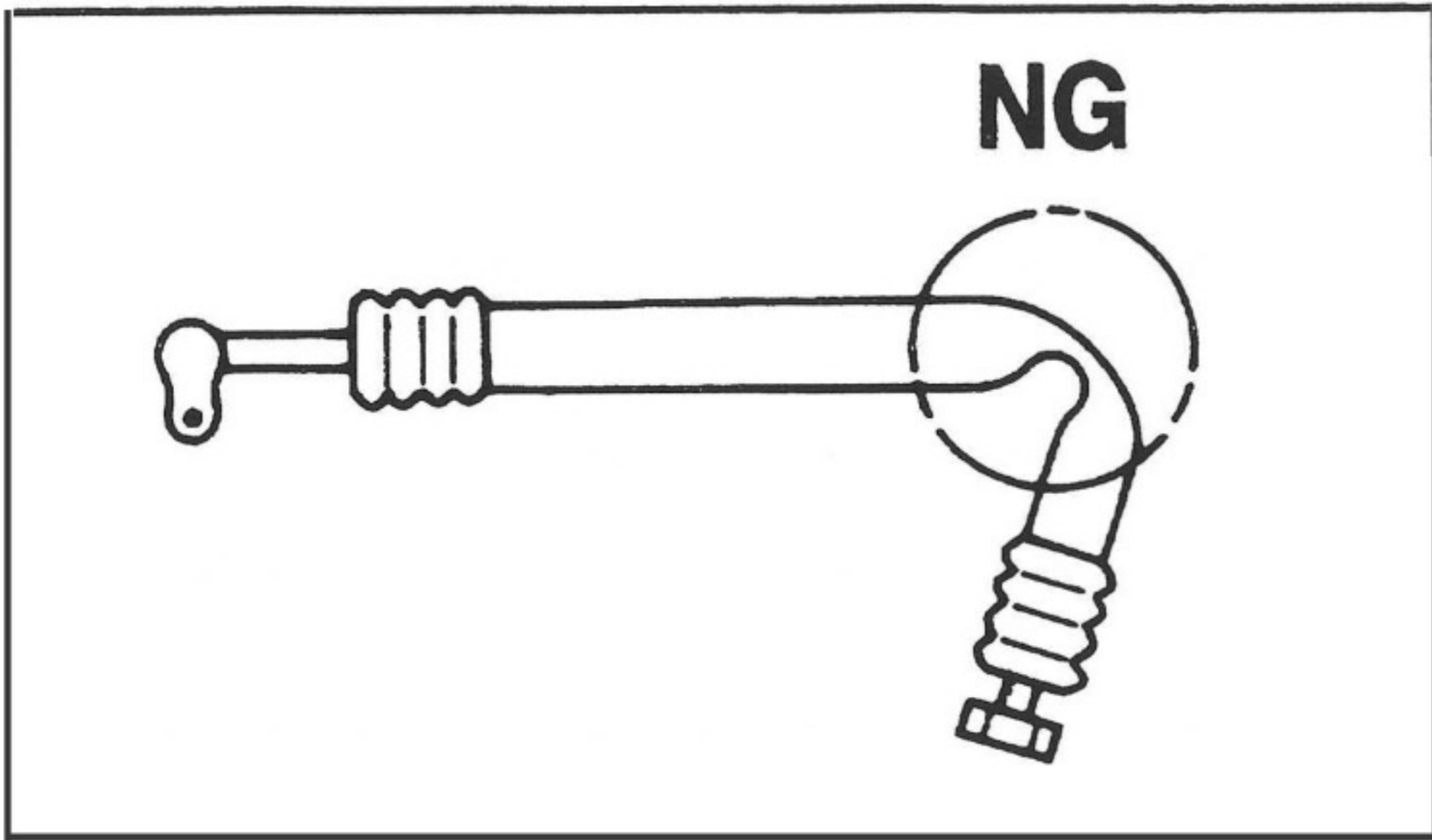

(e) Do not add excessive force to pipes. Do not deform pipes.

(f) Arrange hoses well. For example, it is not allowed to bend or twist engine mounted hoses.

Reason : Resin inside of hoses may be bent or scratched, and it may lower the permeation-proof function.

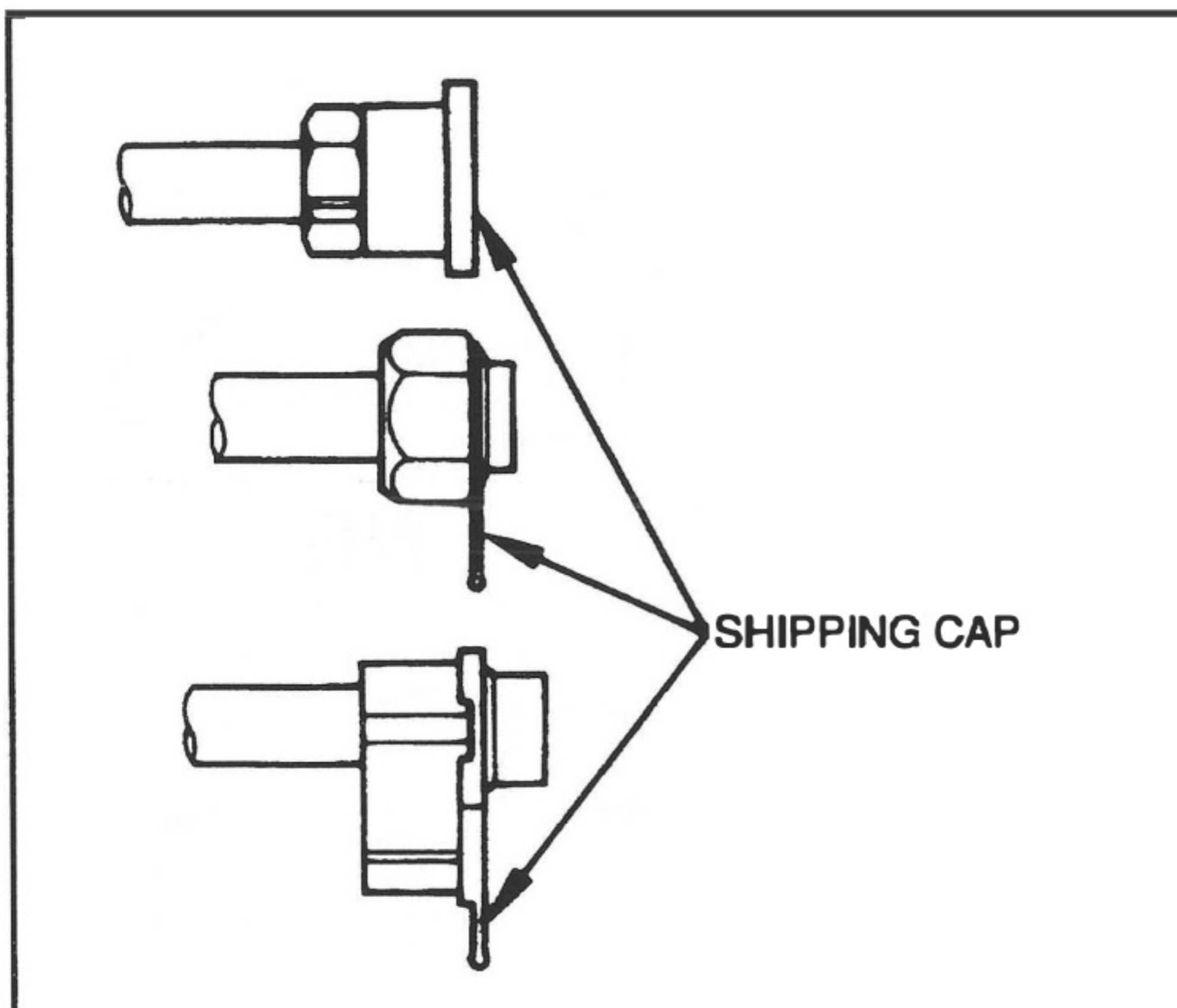

(g) Remove a shipping cap just before connecting pipes.

Reason : To keep O-rings or O-ring seals from dust.

(h) During air conditioning installation, confirm there is no interference between the pipes and vehicle parts. (Keep proper clearances.)

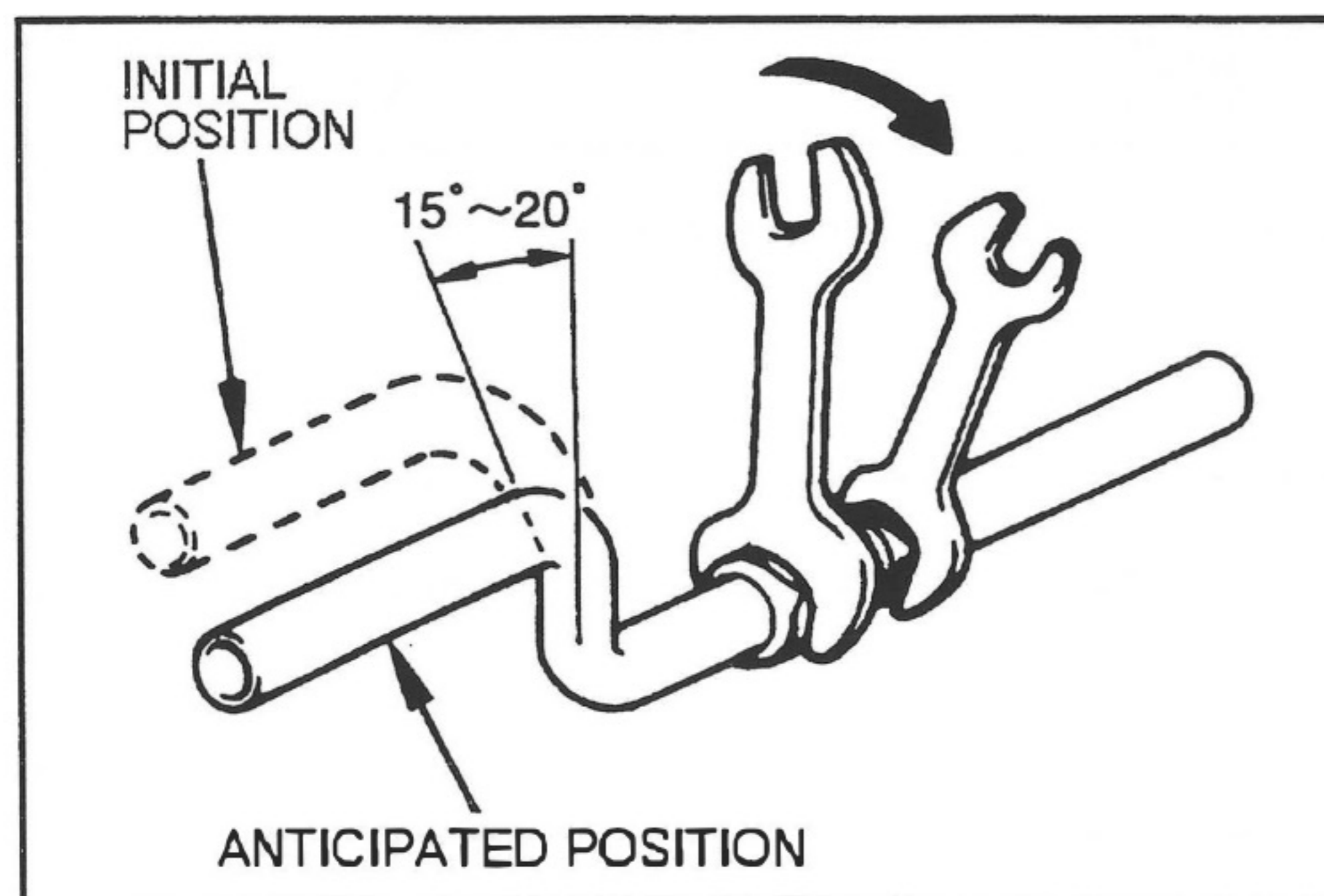

(2) Nut union-type

(a) Always assemble pipes using 2 wrenches.

(b) Pipes will rotate from 15° to 20° clockwise during tightening, so anticipate the displacement caused by rotation of the nut and then mount pipes.

(c) When finally tightening pipes, do not rotate the fixed side (the female side).

## 1-6 GENERAL PRECAUTIONS IN ASSEMBLY

- (1) Be careful to keep parts, service tools, mating parts of various service equipment (including O-rings) free from unspecified oil or dust.
- (2) Avoid using refrigerant oil (such as ND-8 or ND-9) near painted surfaces and resin materials (acrylic resin, ABS plastic, or polycarbonate).
- (3) Remove a receiver shipping cap only just before mounting (connecting pipes). Also mount a receiver last of all the A/C system parts, or at least assemble system parts while the receiver shipping cap is removed for only a short time (for 1 hour or less).

## 1-7 CHARGING REFRIGERANT (HFC-134a)

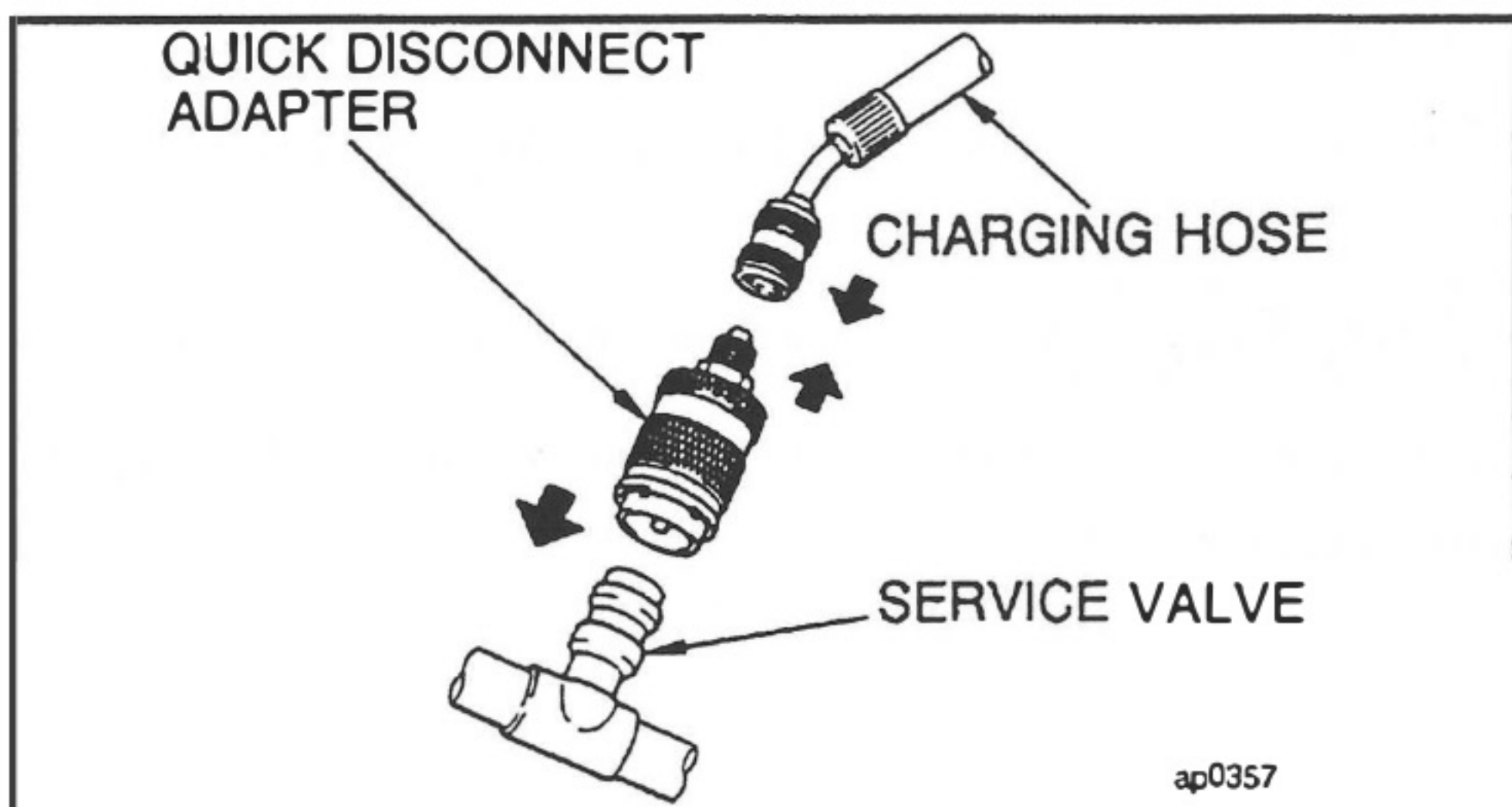

- (1) Connect the quick disconnect adapters to charging hoses.
- (2) Remove the caps from the service valves on the refrigerant line.
- (3) Install the manifold gauge set to the service valves.
  - (a) Close both high and low pressure valves of manifold gauge set.
  - (b) Connect the quick disconnect adapters to the service valves.

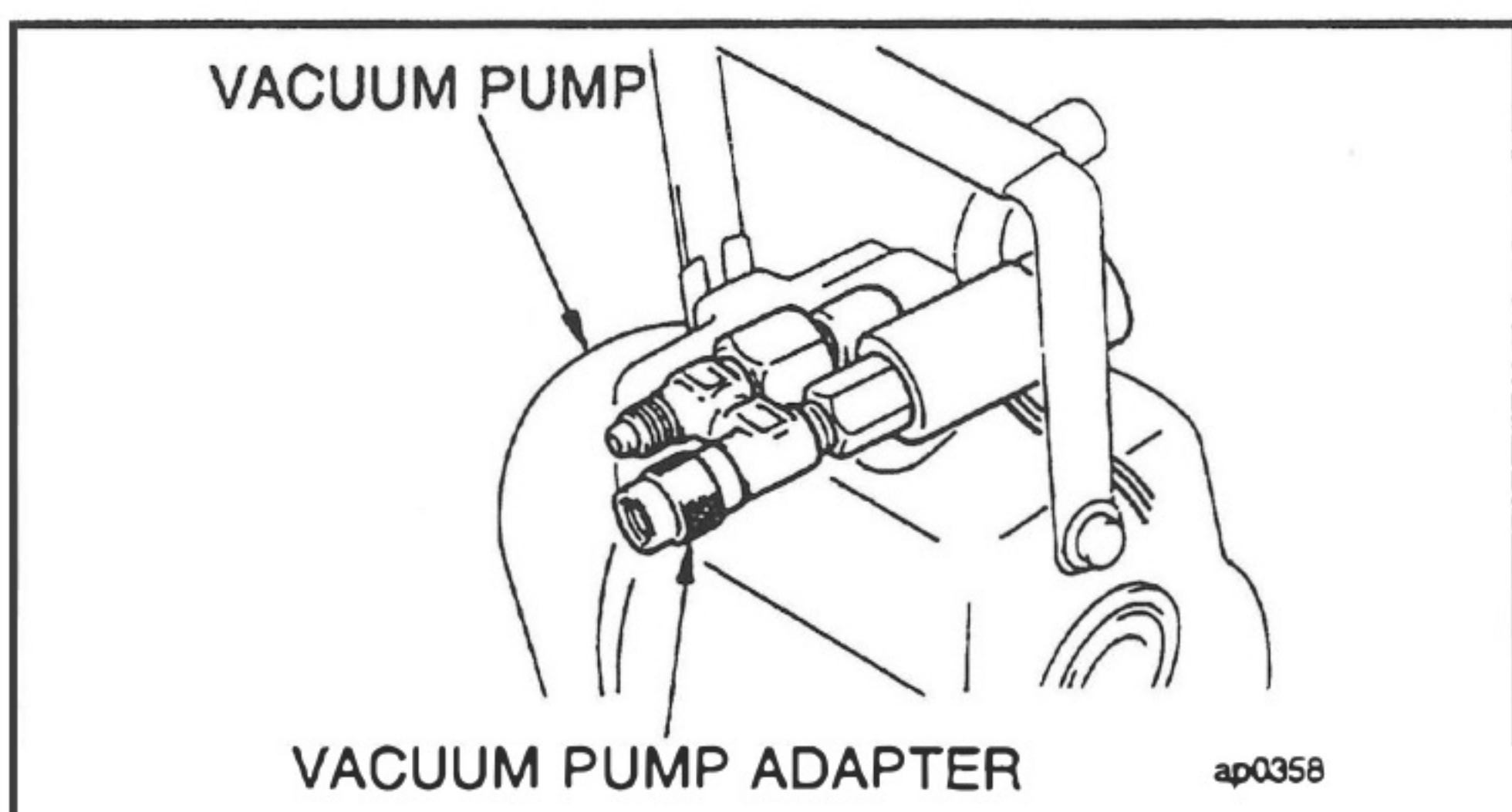

- (4) Evacuate air in refrigeration system.
  - (a) Connect the vacuum pump adapter to the vacuum pump.

### ! CAUTION

*When connecting charging hose to A/C charging valve, do not use excessive force. Excessive force may damage charging valves and deform pipes.*

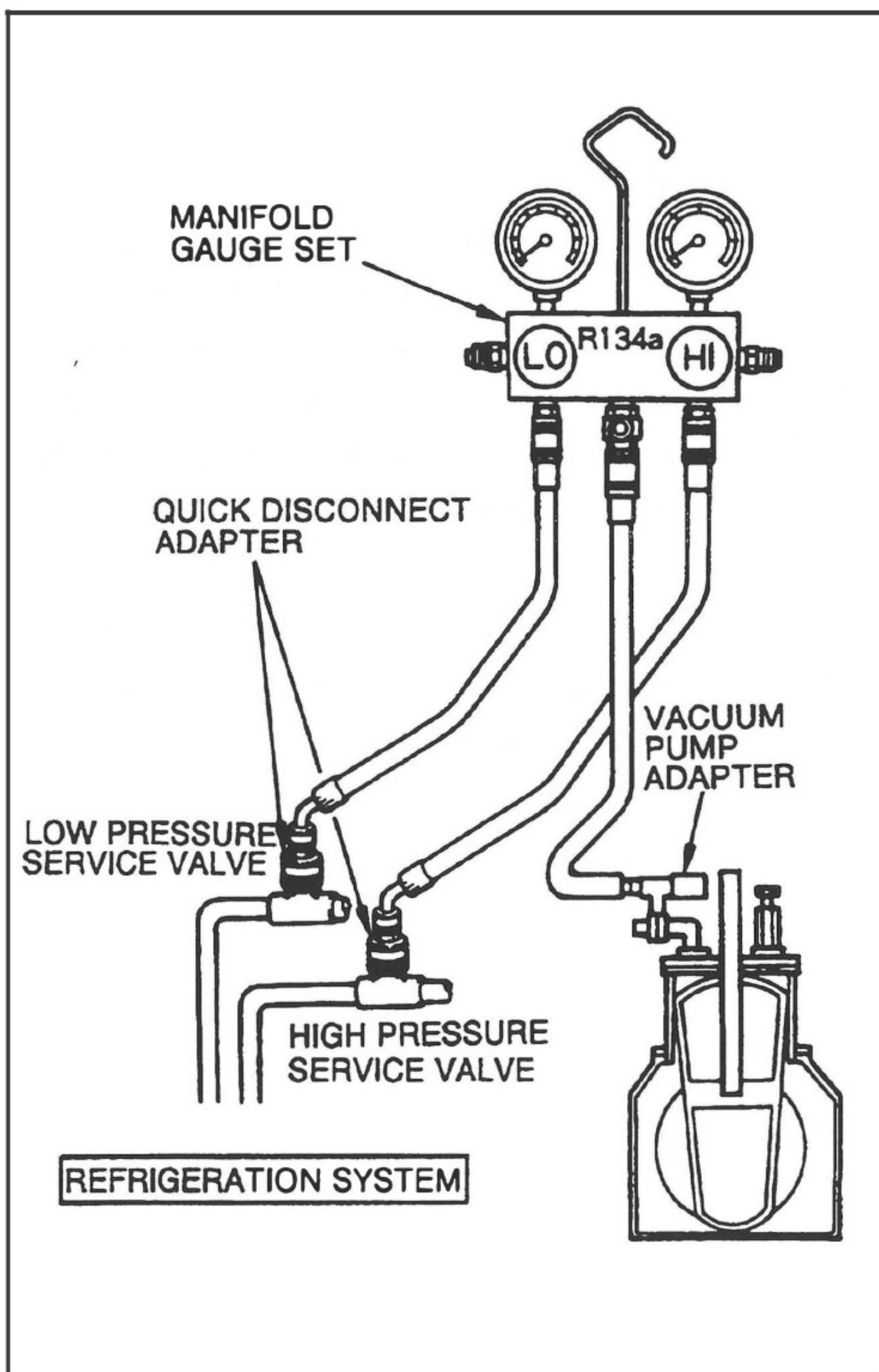

- (b) Connect the center hose of the manifold gauge set to the vacuum pump adapter.
- (c) Open both the high and low pressure valves and turn on the vacuum pump.
- (d) After ten minutes or more, check that the low pressure gauge indicates  $-0.1 \text{ Mpa}$  (  $-750 \text{ mm Hg}$  ) or less.

### NOTE

*If the reading is not  $-0.1 \text{ Mpa}$  (  $-750 \text{ mm Hg}$  ) or less, close both valves of manifold gauge set and stop vacuum pump.*

*Check the system for leaks and repair as necessary.*

- (e) Close both valves and turn off the vacuum pump.
- (f) Leave the system in this condition for five minutes or longer and check that there is no change in the gauge indicator.

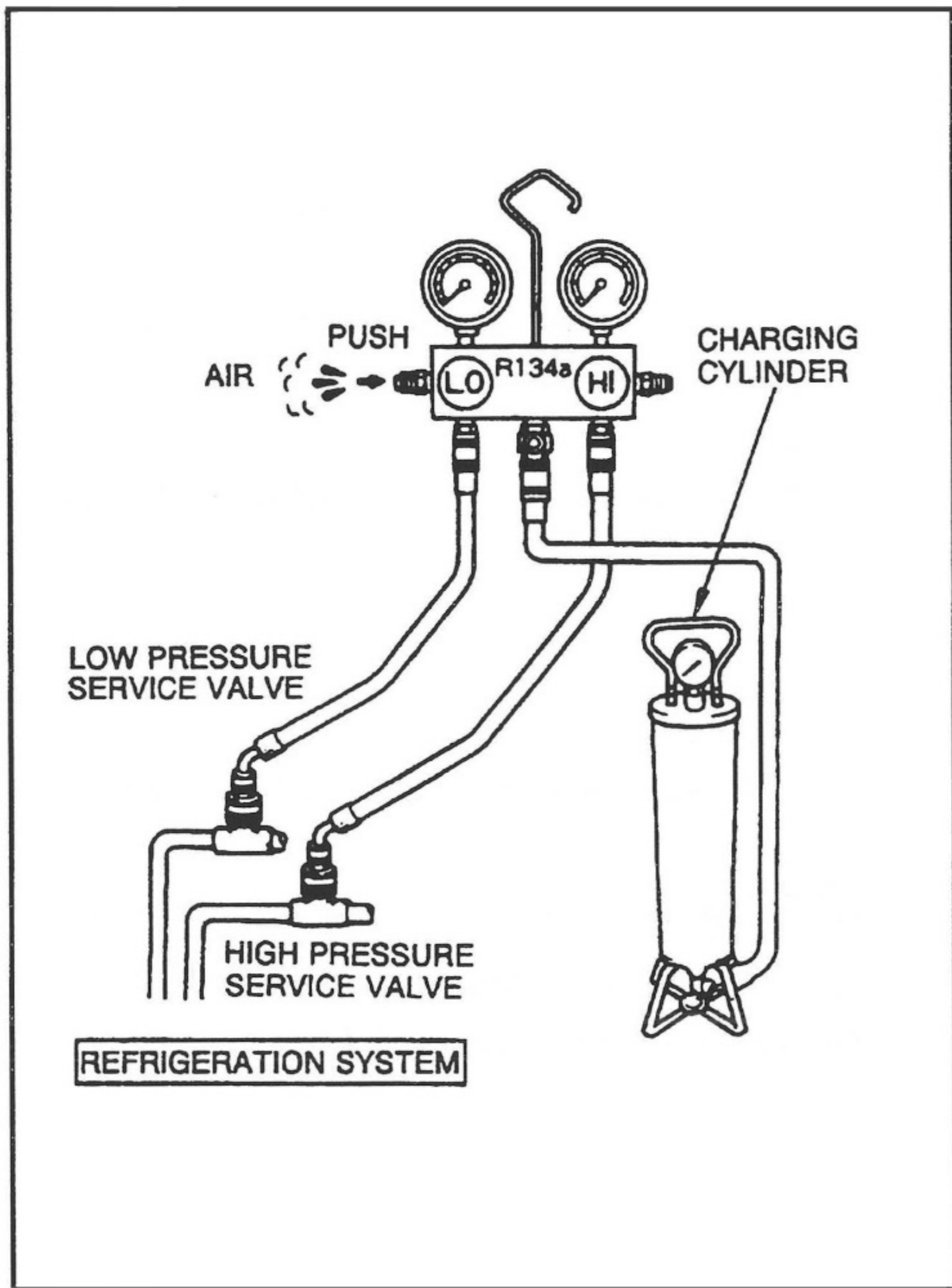

- (5) Install charging cylinder.
  - (a) Charge the proper amount of refrigerant into the charging cylinder.
  - (b) Connect the center hose to the charging cylinder.

**!CAUTION**

*Do not open both high and low pressure valves of manifold gauge set at this time.*

- (c) Open the valve of charging cylinder.
- (d) Press the valve core on the side of manifold gauge and expel the air inside of the center hose.

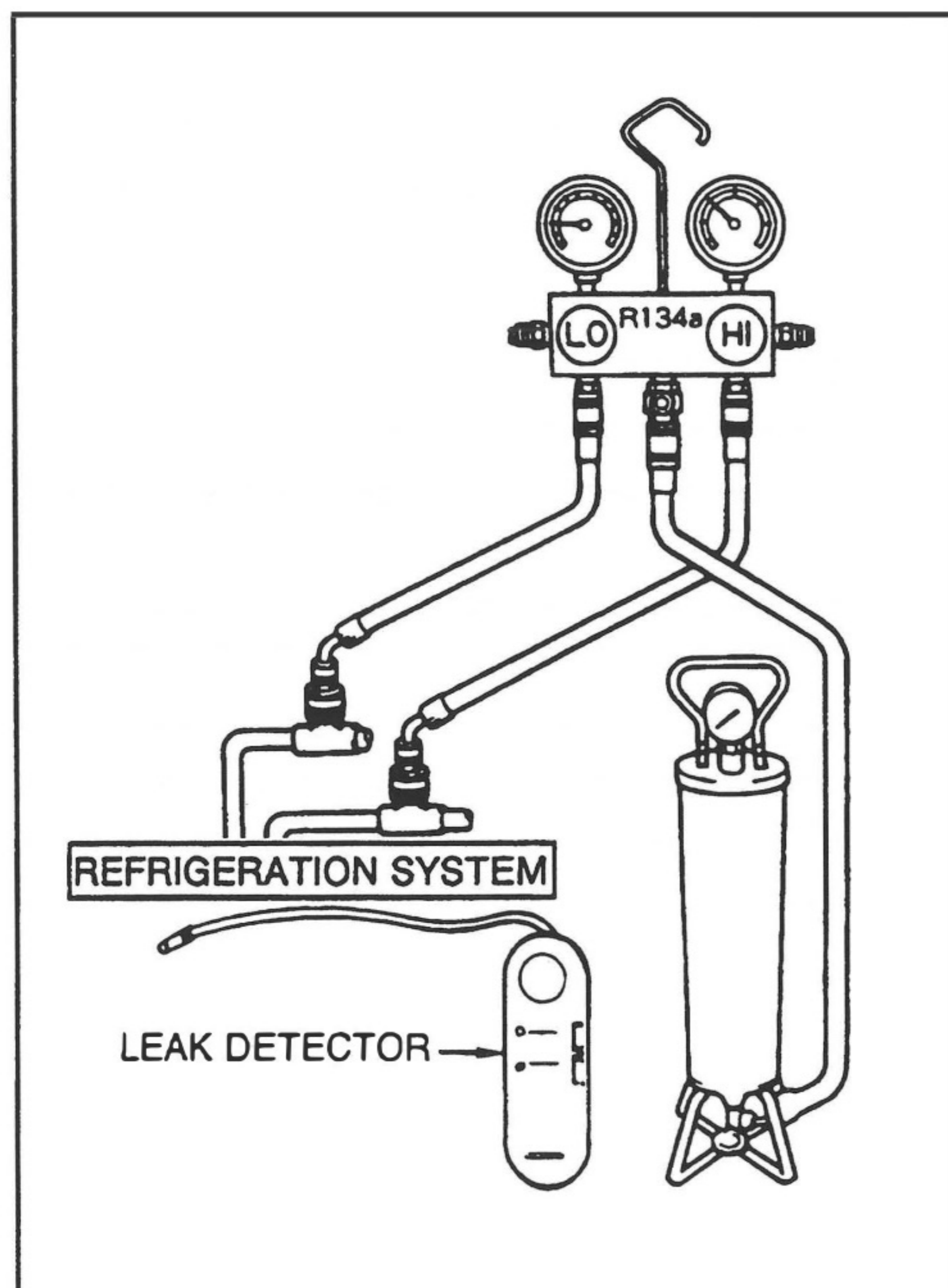

- (6) Inspect the refrigeration cycle for leaks.
  - (a) Open the high pressure valve and charge refrigerant.
  - (b) When the low pressure gauge indicates 98 kPa (1kgf/ cm<sup>2</sup>, 14 psi), close the high pressure valve.
  - (c) Using the leak detector, check the cycle for leakage.
  - (d) If leak is found, repair the faulty component or connection. And evacuate the air in refrigeration cycle.

**!CAUTION**

*Use refrigerant recovery/recycling machine to recover the refrigerant whenever replacing parts.*

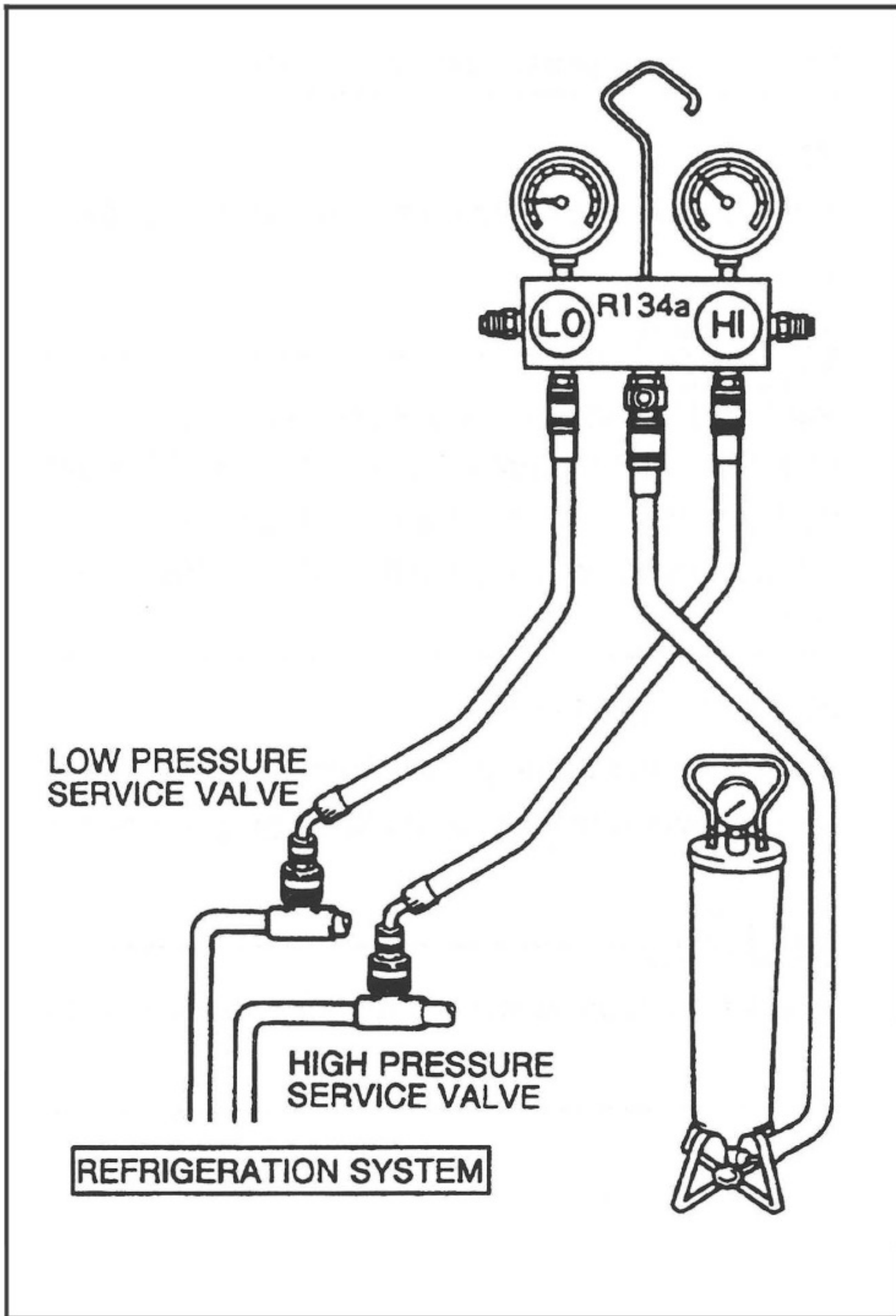

(7) Charge refrigerant into the refrigeration cycle.

**! CAUTION**

1. Never run the engine when charging the system through the high pressure side.
2. Do not open the low pressure valve when the cycle is being charged with liquid refrigerant.

- (a) Open the high pressure valve fully.
- (b) Charge the specified amount of refrigerant, then close the high pressure valve.

**NOTE**

A fully charged system is indicated by the sight glass being free of any bubbles.

- (8) Remove manifold gauge set from service valves.
  - (a) Close both valves of manifold gauge set.
  - (b) Disconnect quick disconnect adapters from service valves.
- (9) Install the caps to service valves on the refrigerant line.

**! CAUTION**

1. After charging refrigerant, be sure to tighten the charging valve cap.  
Recommended tightening torque specification: 0.25 N•m or more
2. If a valve cap is removed, dust or moisture can enter, and the seal portion on the valve is corroded. This deteriorates sealing performance, leading to a possible refrigerant leak.

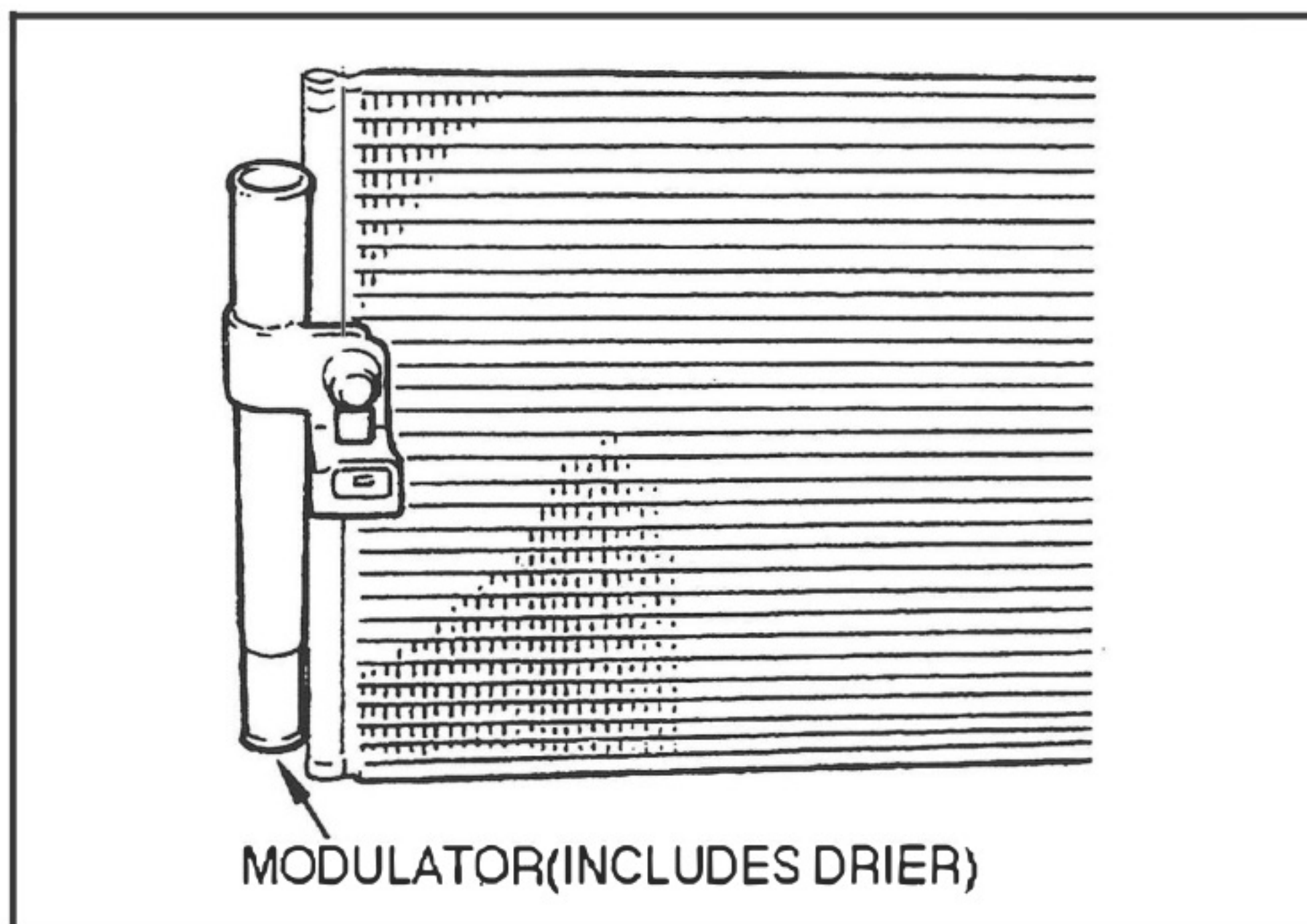

**<A/C with Sub-cool condenser>**

**NOTE**

The point which bubbles disappear is before the system is fully charged. Make sure to charge the specified amount using a charging cylinder when charging refrigerant. (The refrigeration cycle with a sub-cool condenser does not come with a conventional receiver. The tank on the condenser side serves as the receiver.)

## 1-8 QUICK JOINT REMOVER INSTRUCTIONS (Equipped model only)

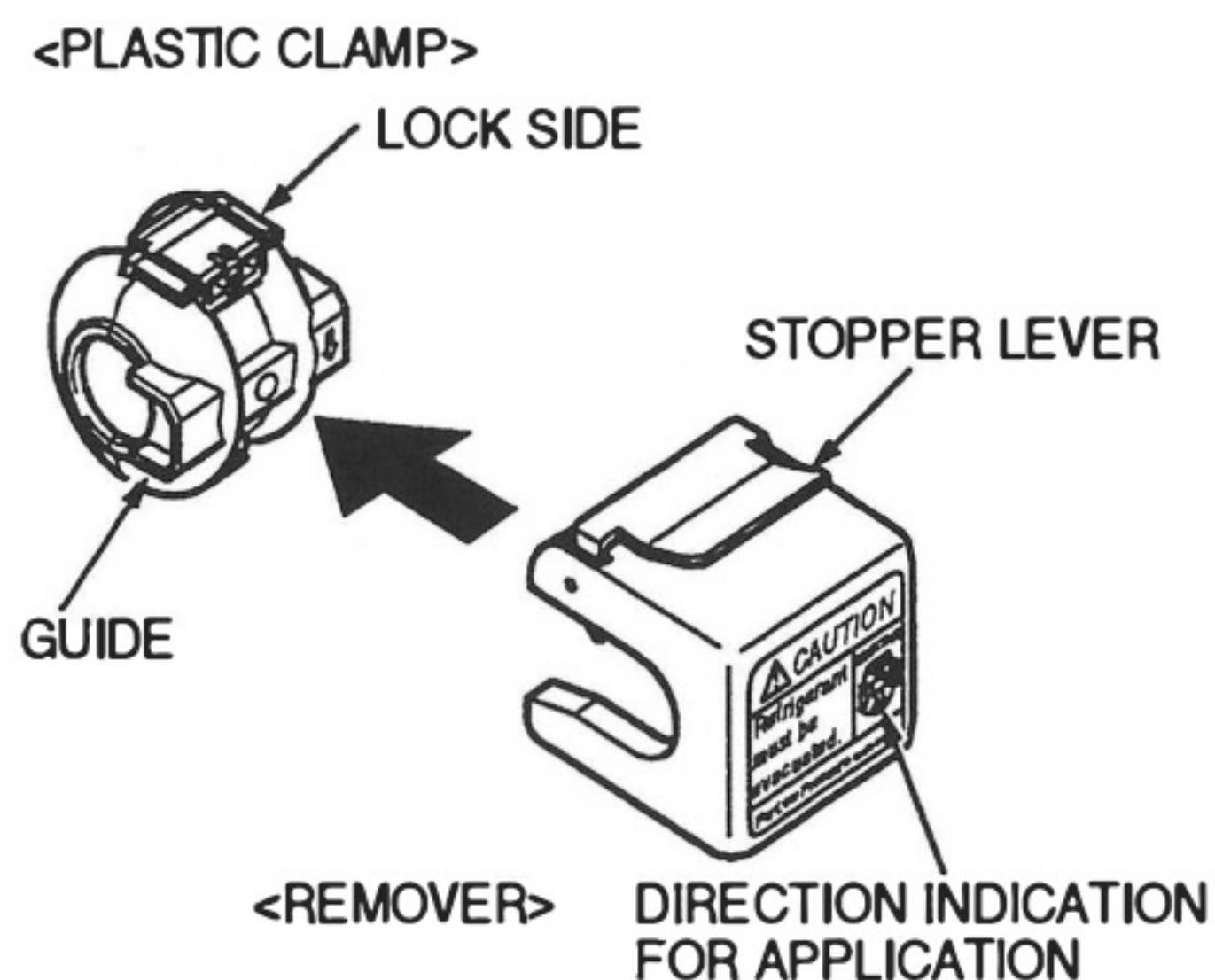

### 1. SETTING

Confirm the remover direction respective to the direction indicated.

#### **! CAUTION**

Refrigerant must be evacuated before using the remover. Removing the plastic clamp from a system filled with refrigerant may cause frostbite and eye damage. Remover must be keep away from engine coolant and battery electrolyte.

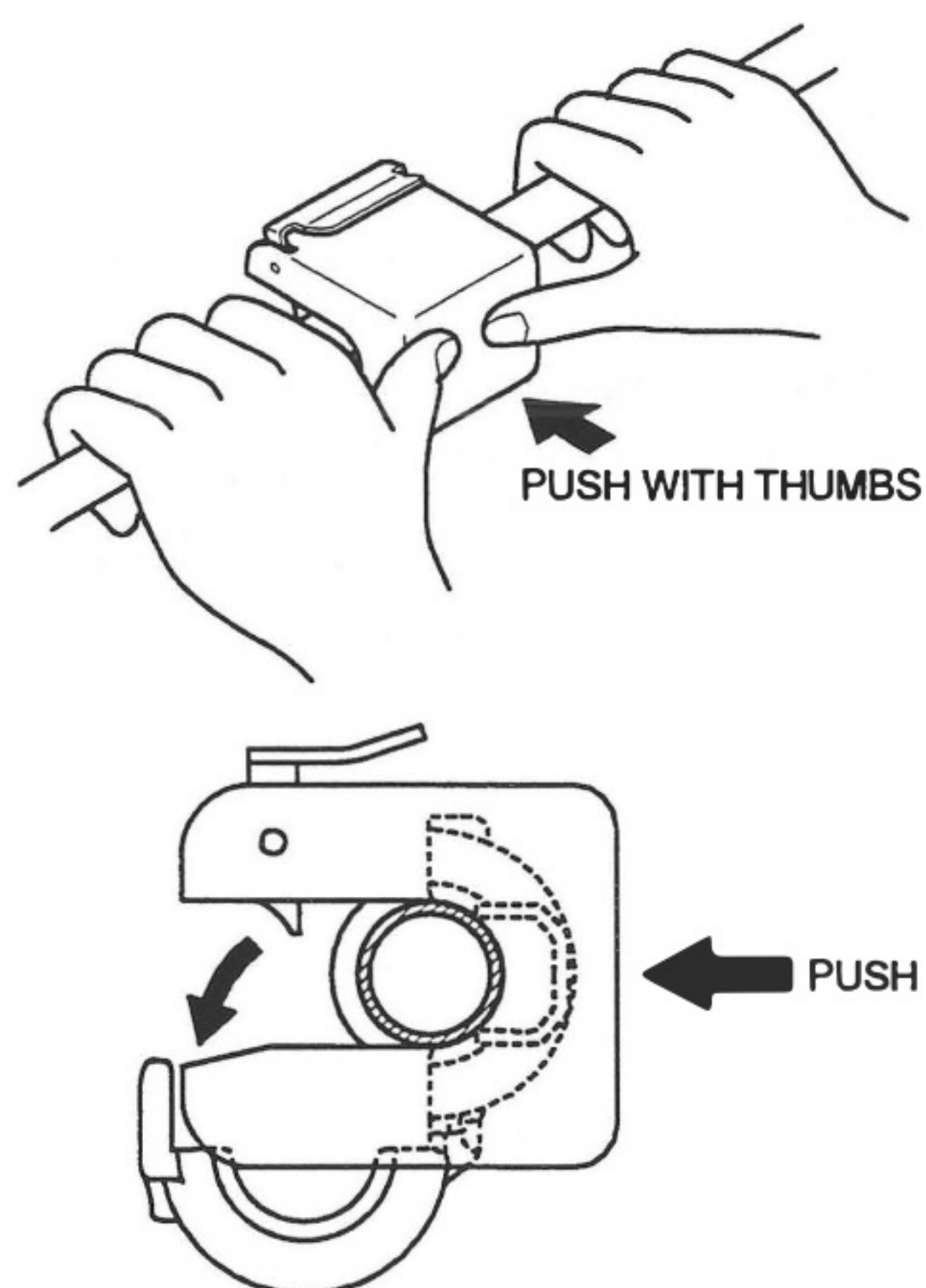

### 2. RELEASING CLAMP LOCK

- (1) Attach the remover to the plastic clamp.
- (2) Push the remover with thumbs until the clamp lock releases.

#### **! CAUTION**

Do not apply excessive force to avoid deformation of A/C tubes.

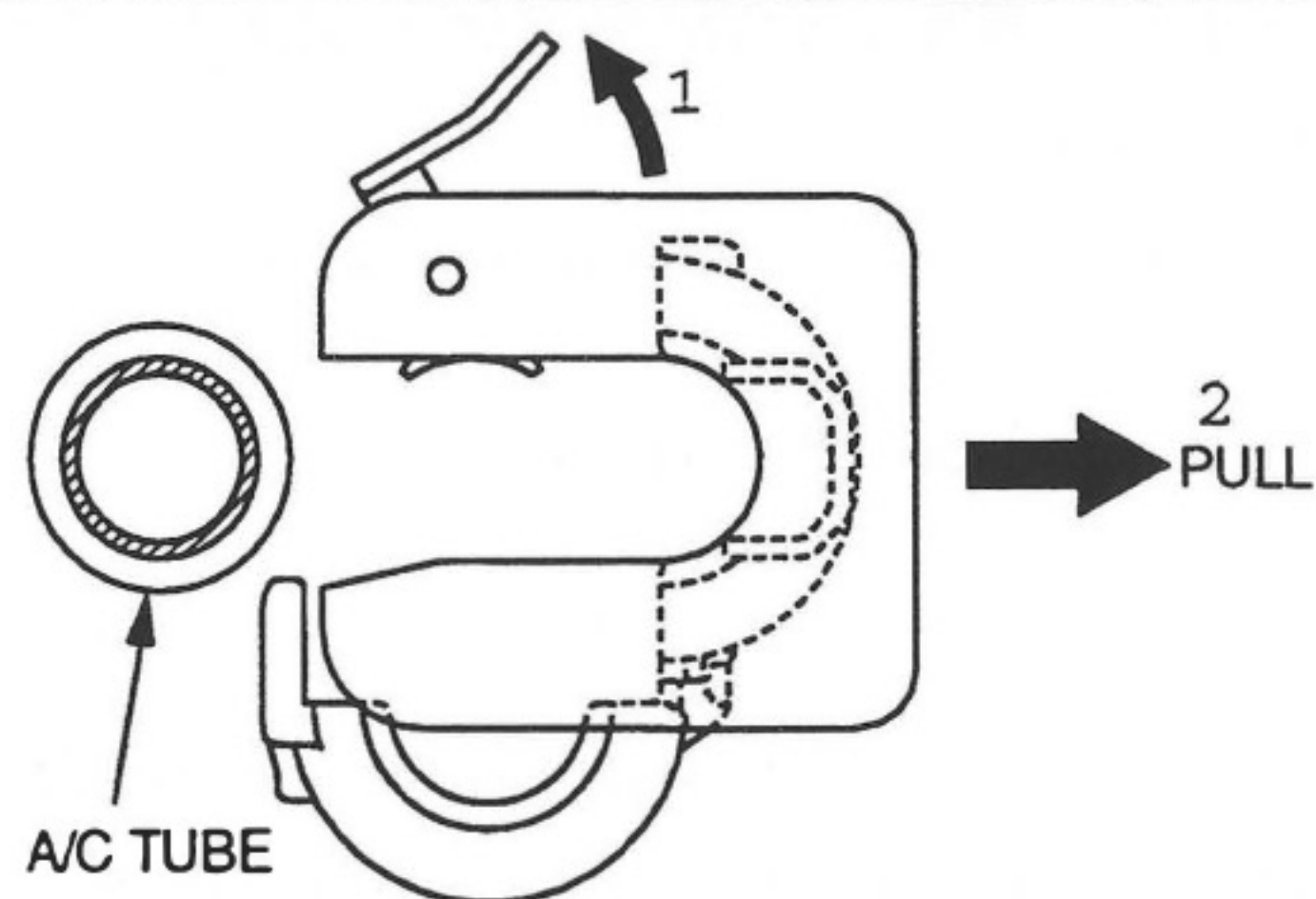

### 3. RELEASING THE REMOVER

- (1) Pull the remover to separate the plastic clamp and tubes.
- (2) Lift the stopper lever and pull out the remover from A/C tubes.

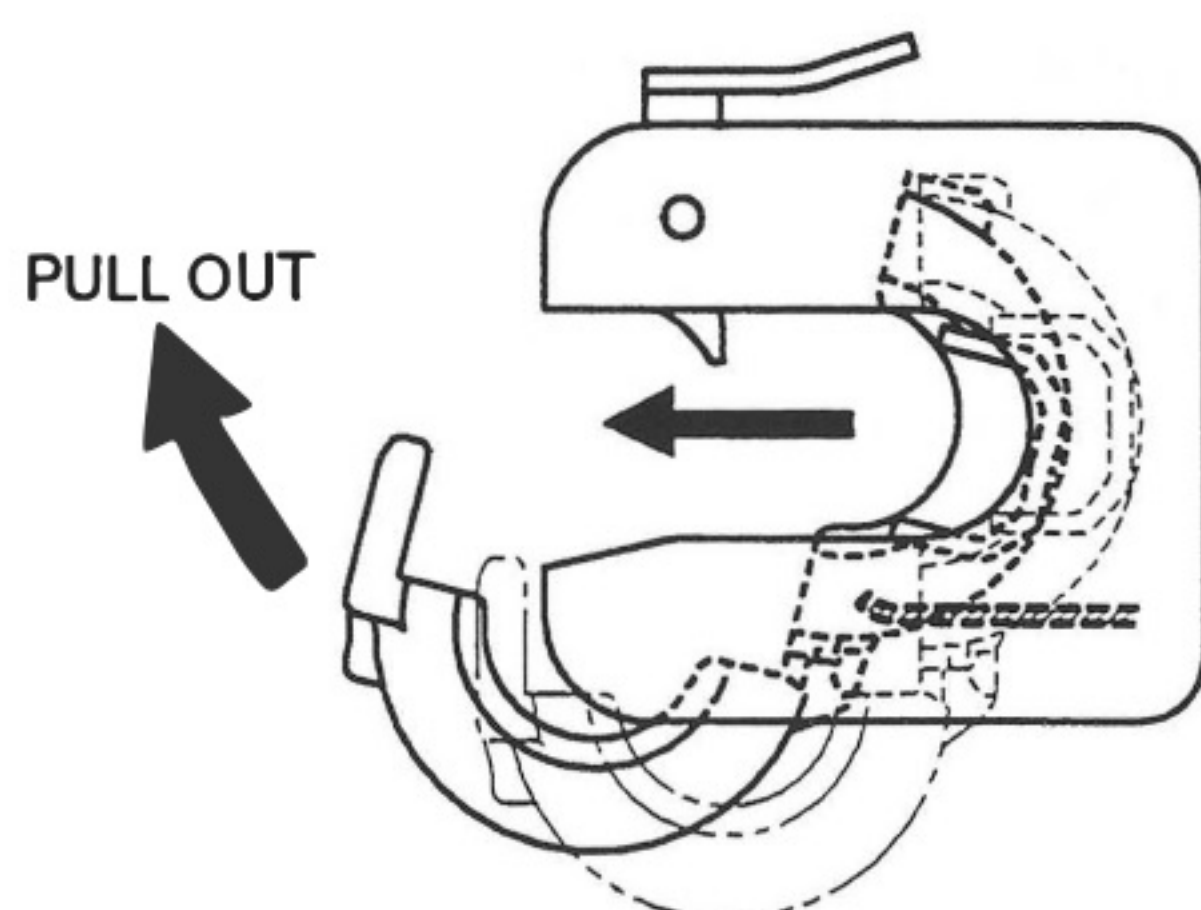

### 4. CLAMP REMOVAL

Pull out the plastic clamp from the remover.

#### **NOTE**

Do not bend the needles while removing the plastic clamp from remover. Deformation of needles may cause difficult operation of the clamp remover.

## 2. INSTALLATION

### ⚠ CAUTION

1. Be sure to use the correct oil, refrigerant and charging/recovery equipment.
2. Before starting installation, read all "PRECAUTIONS FOR SAFETY INSTALLATION" thoroughly and follow the instructions described in it.
3. Before starting installation, remove the (-) terminal of the battery and ensure seat/floor covers are in position.
4. Take care not to scratch any parts of the vehicle.
5. Sort removed bolts and tapping screws into groups so that they can be reassembled correctly.

### 2-1 INSTALLATION INSIDE PASSENGER COMPARTMENT

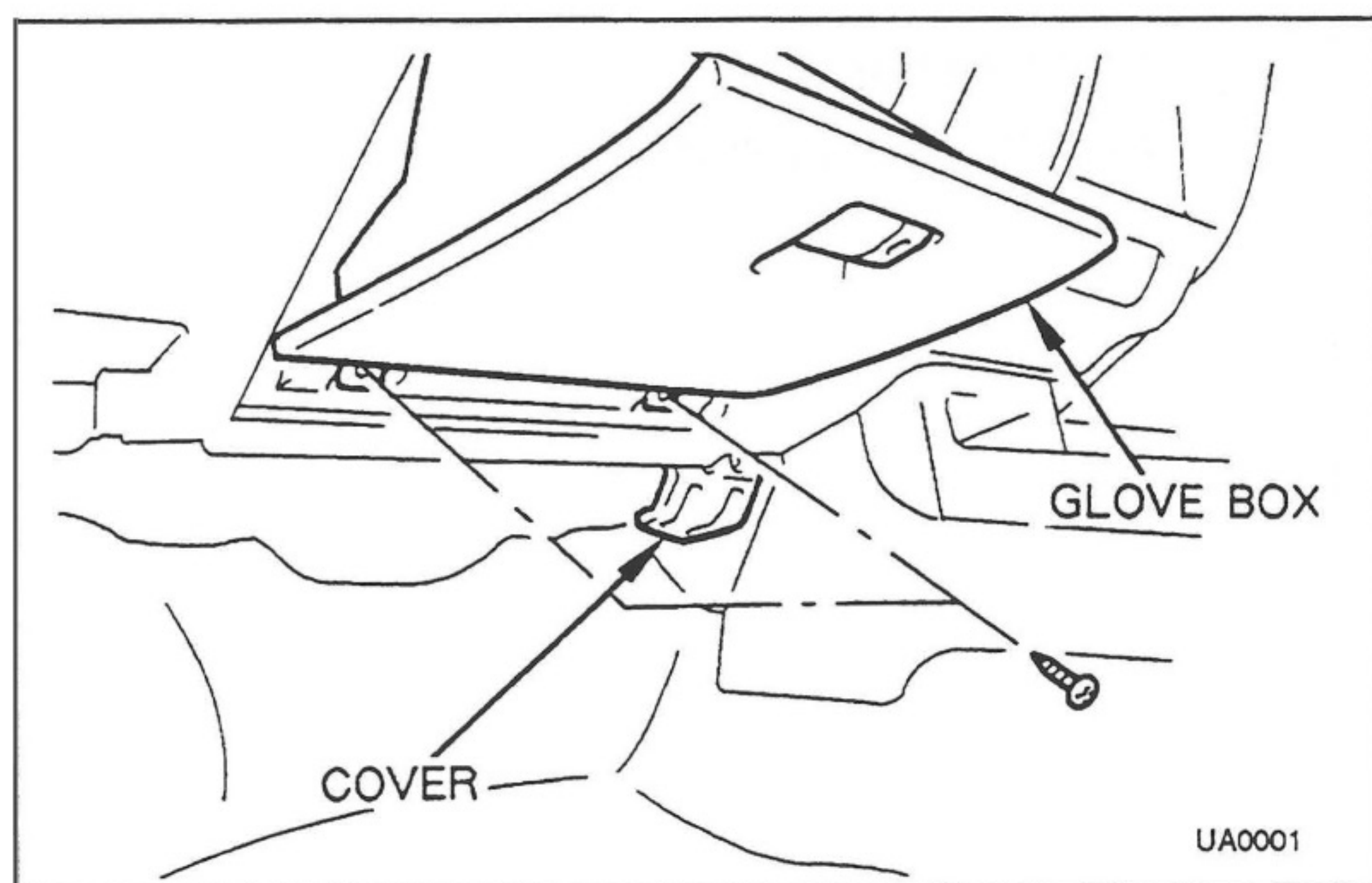

#### (1) REMOVAL OF PARTS

- (a) Glove box
- (b) Cover

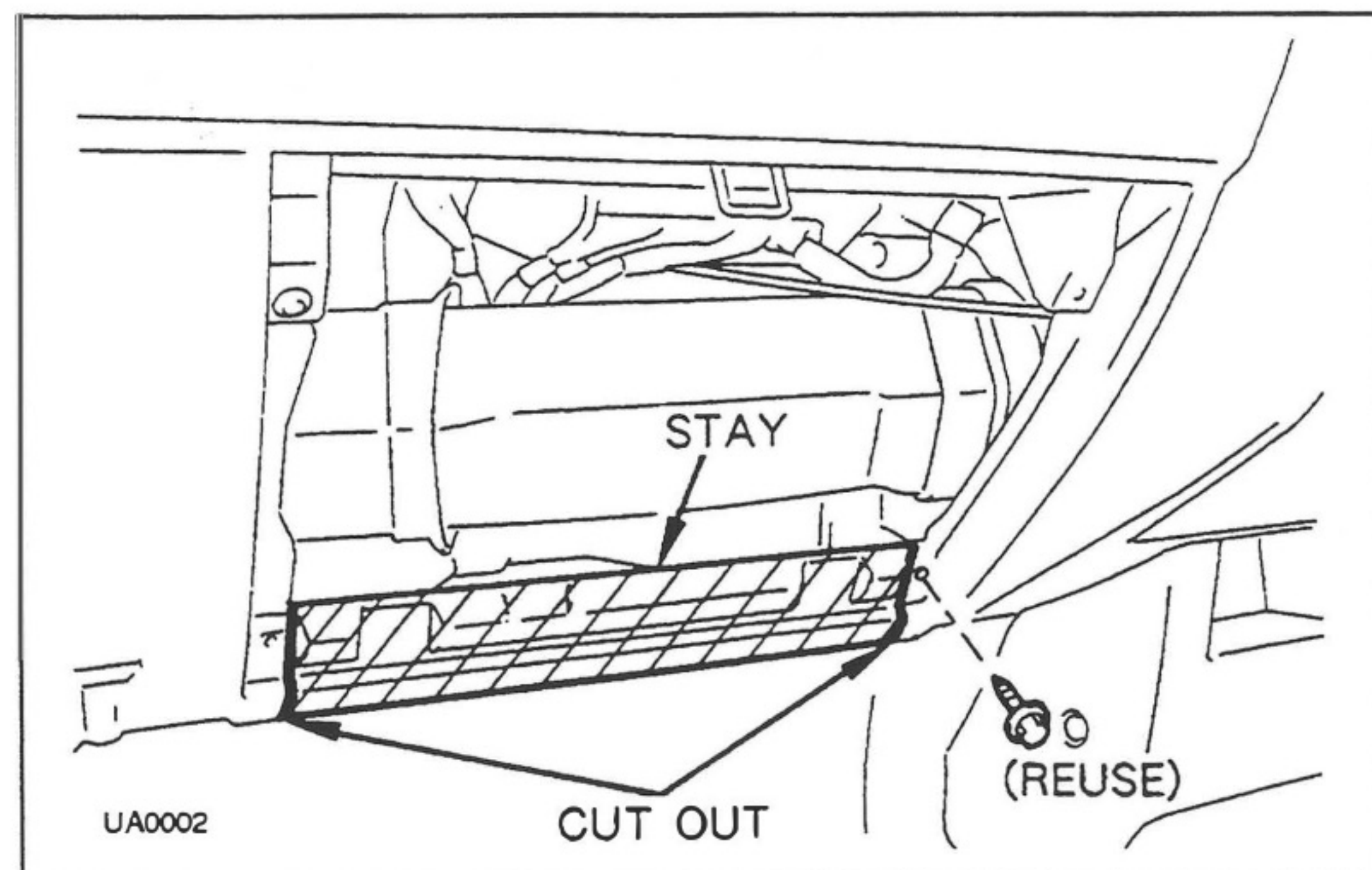

- (c) Cut out the stay

#### NOTE

*Cut out the stay at the 10 mm from the side edge.*

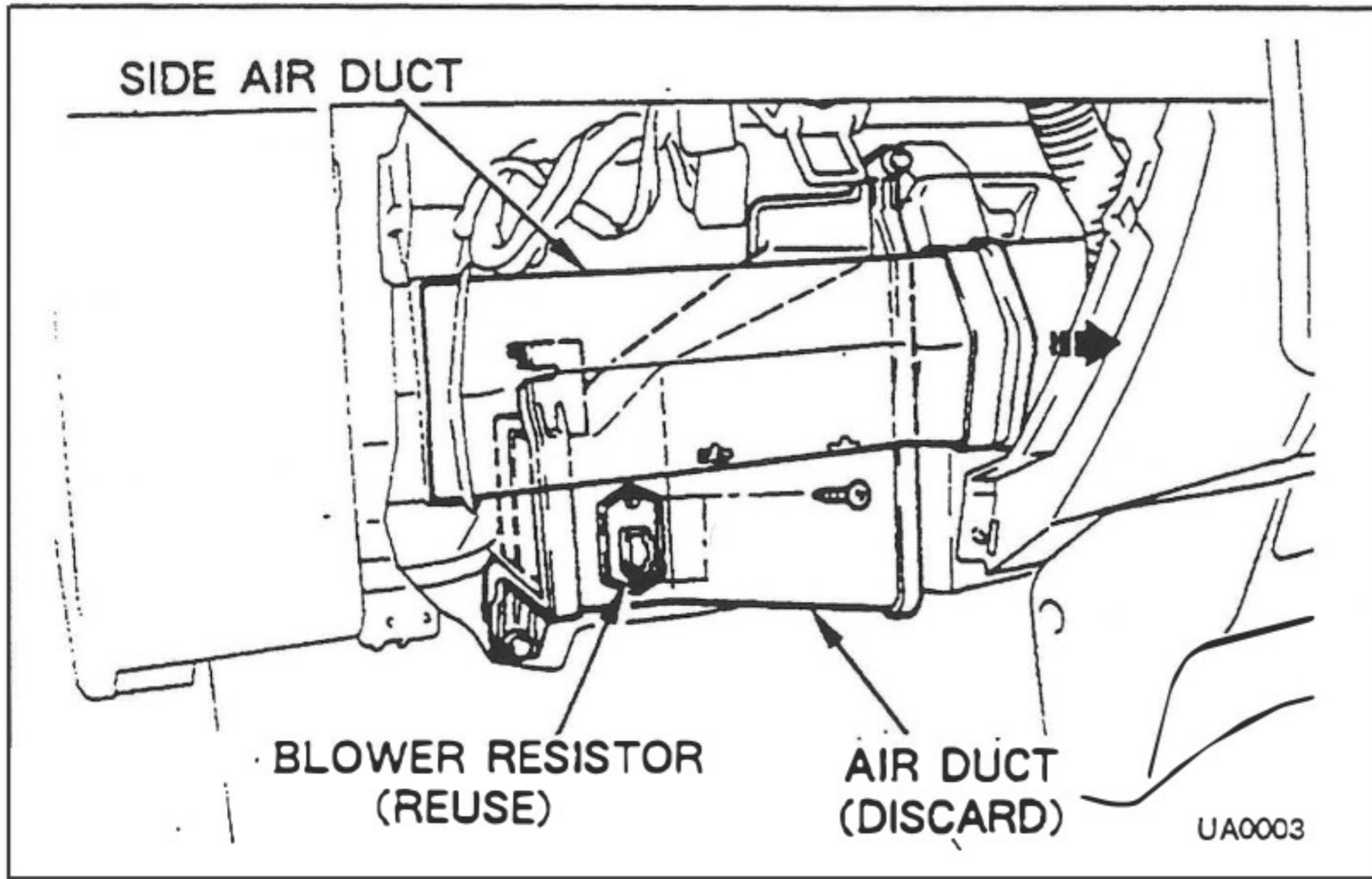

(d) Side air duct

**NOTE**

*Move the side air duct to the right hand side, then pull it.*

(e) Air duct (Discard)

(f) Blower resistor and tapping screws (Reuse)

**NOTE**

*Do not discard the three original tapping screws and the original bolt.*

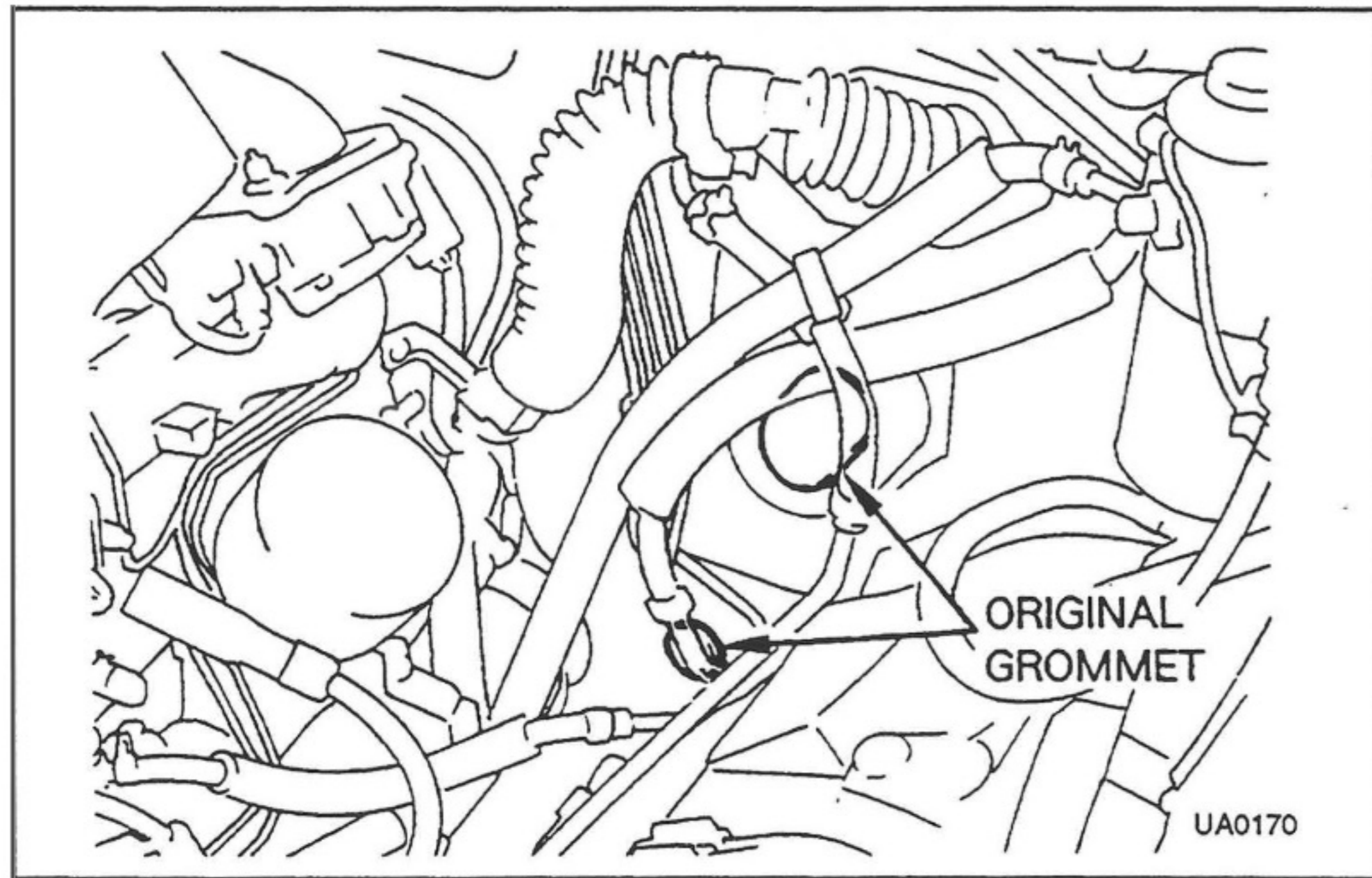

(g) Original grommets (Discard)

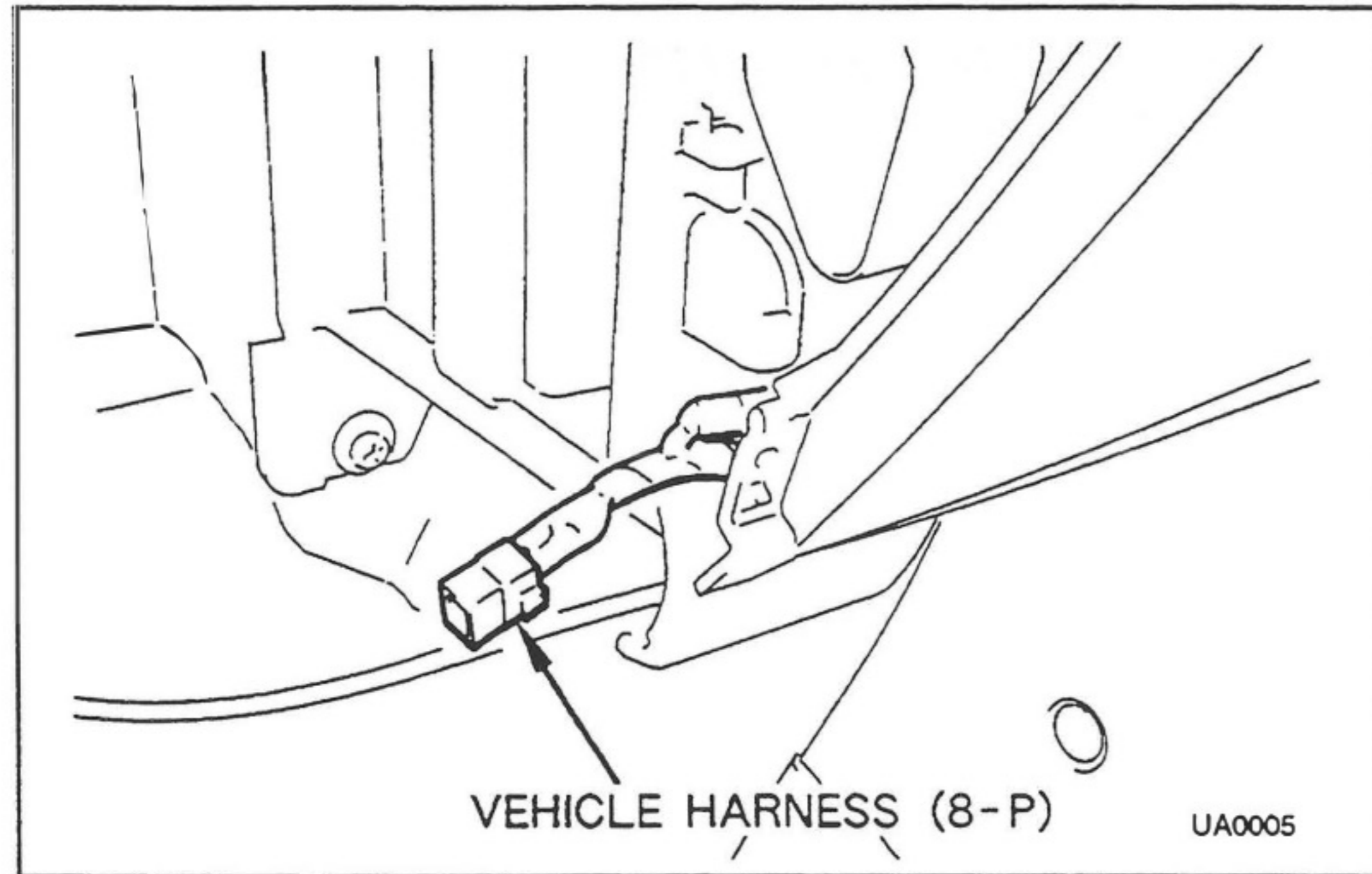

**(2) COOLING UNIT**

(a) Pull the vehicle harness.

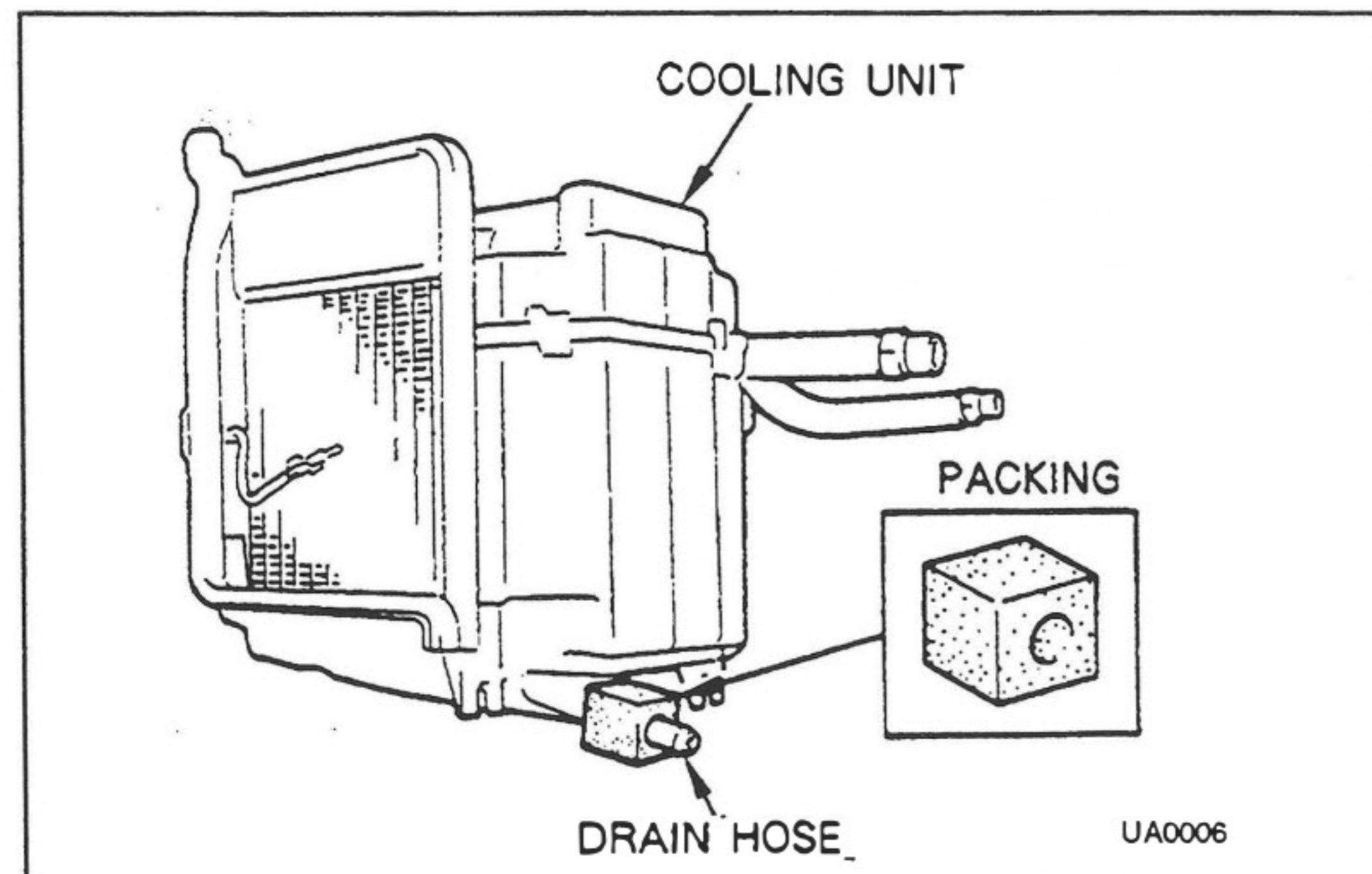

(b) Install the drain hose and packing to the cooling unit.

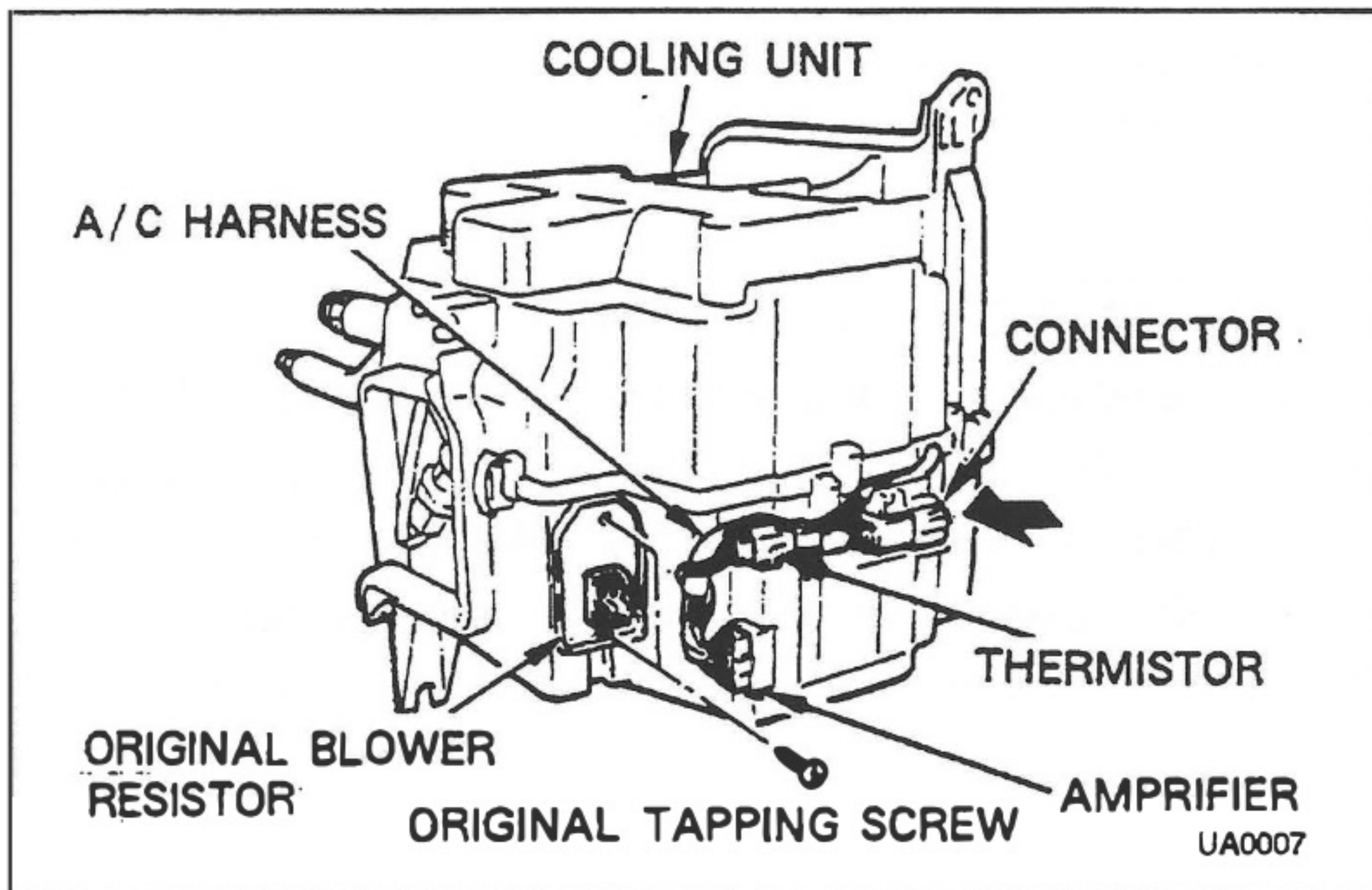

- (c) Install the original blower resistor to the cooling unit using two original tapping screws.
- (d) Install the connector of A/C harness to the cooling unit from the arrow direction.
- (e) Connect the A/C harness to the thermistor and the amplifier.

**NOTE**

*Route the A/C harness inside the thermistor.*

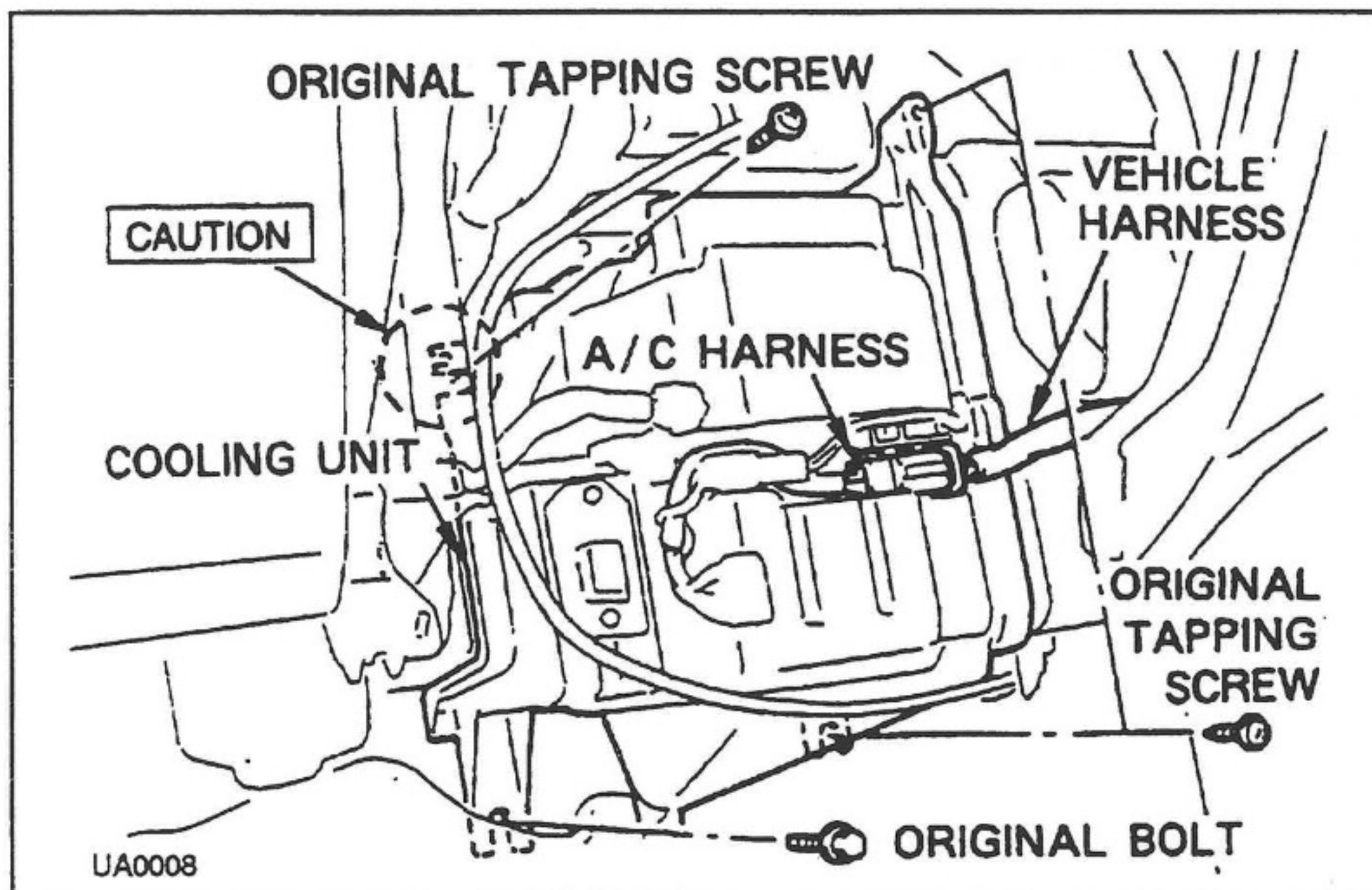

- (f) Install the cooling unit using three original tapping screws and the bolt.
- (g) Connect the vehicle harness to the A/C harness connector.

**CAUTION**

*Align the cut point of cooling unit with the edge of blower unit, when installing it.*

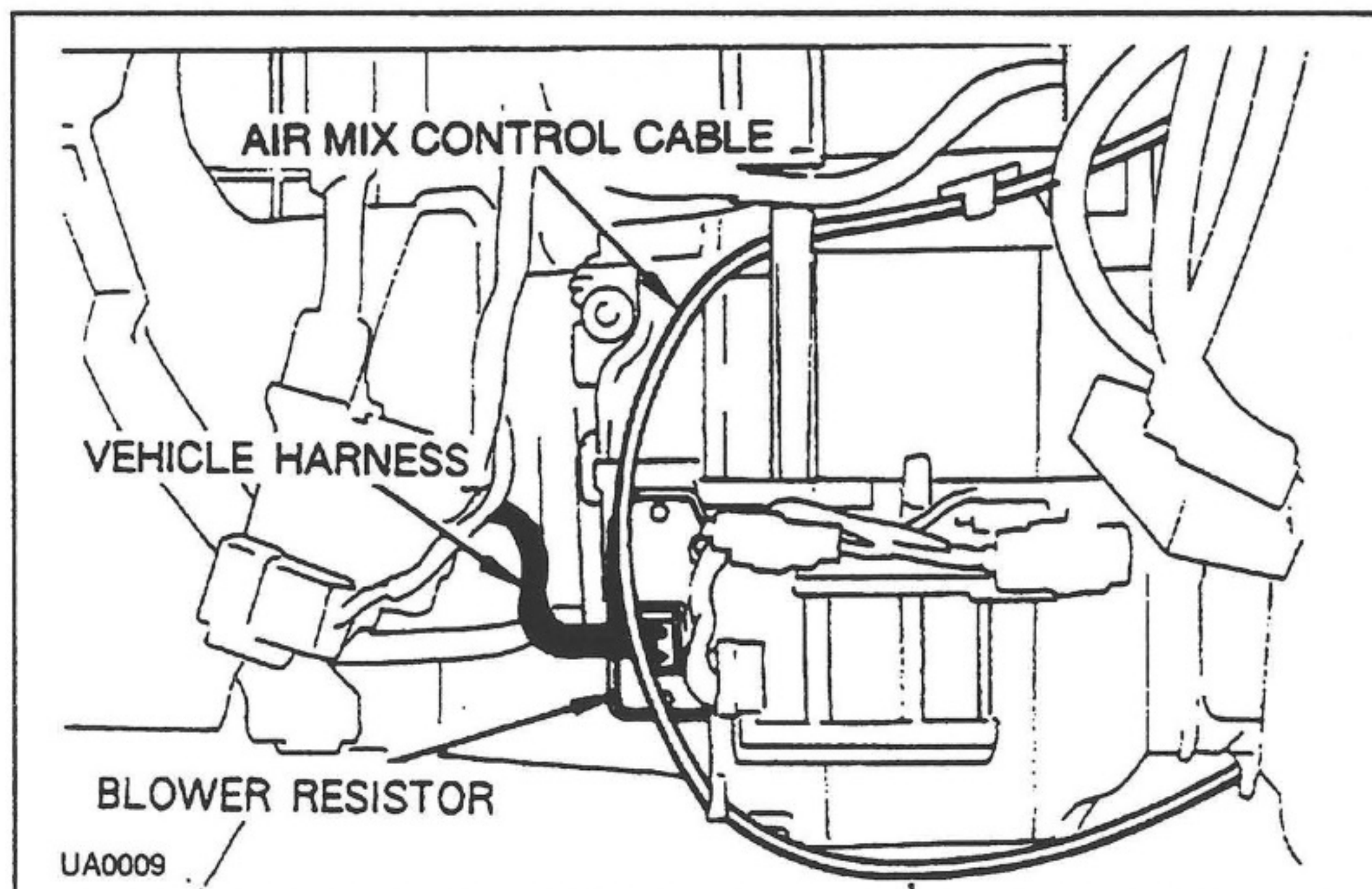

- (h) Connect the vehicle harness to the blower resistor.
- (i) Secure the air mix control cable to the cooling unit.

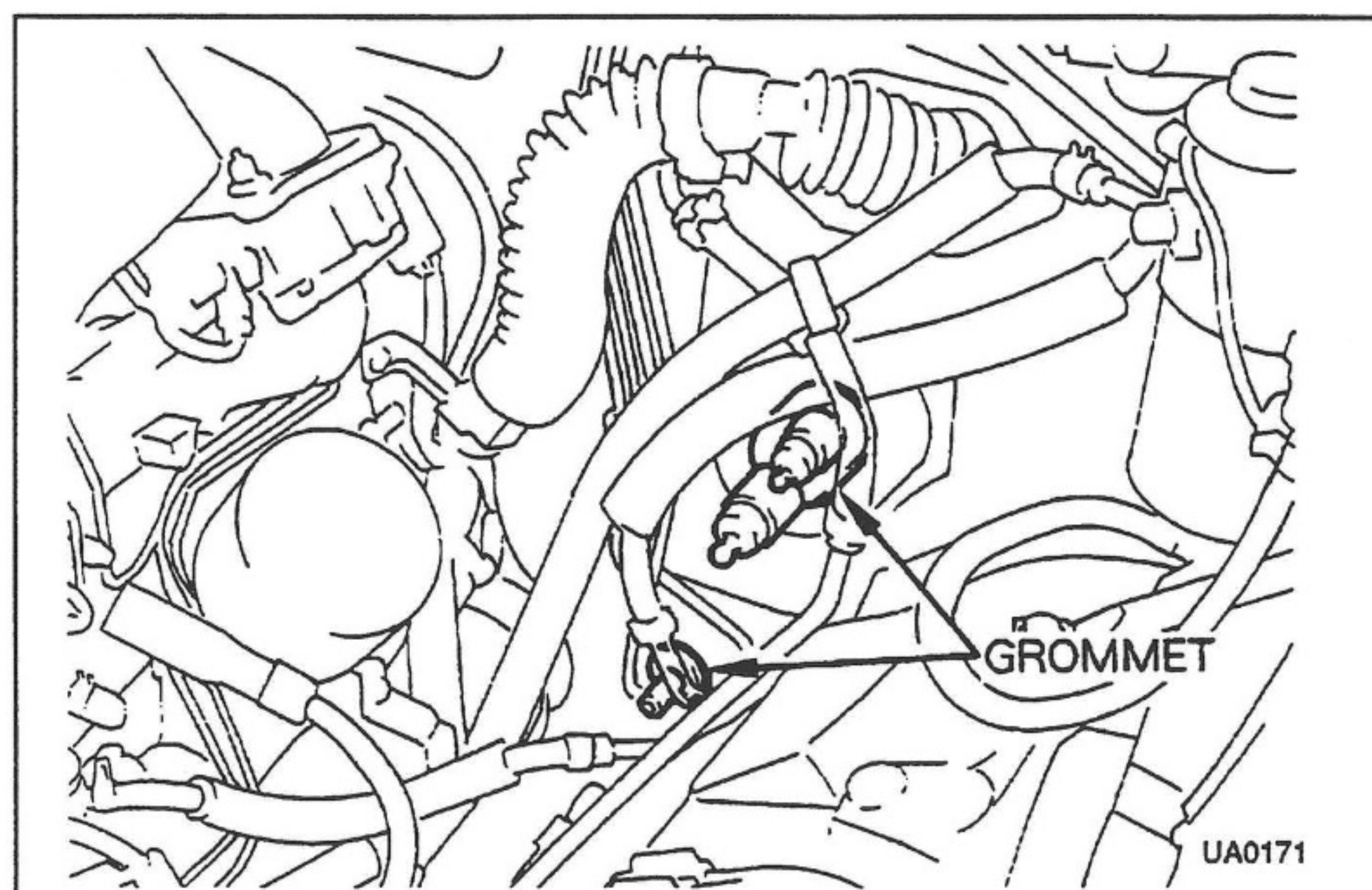

**(3) GROMMET**

- (a) Install the grommets from the engine compartment side.

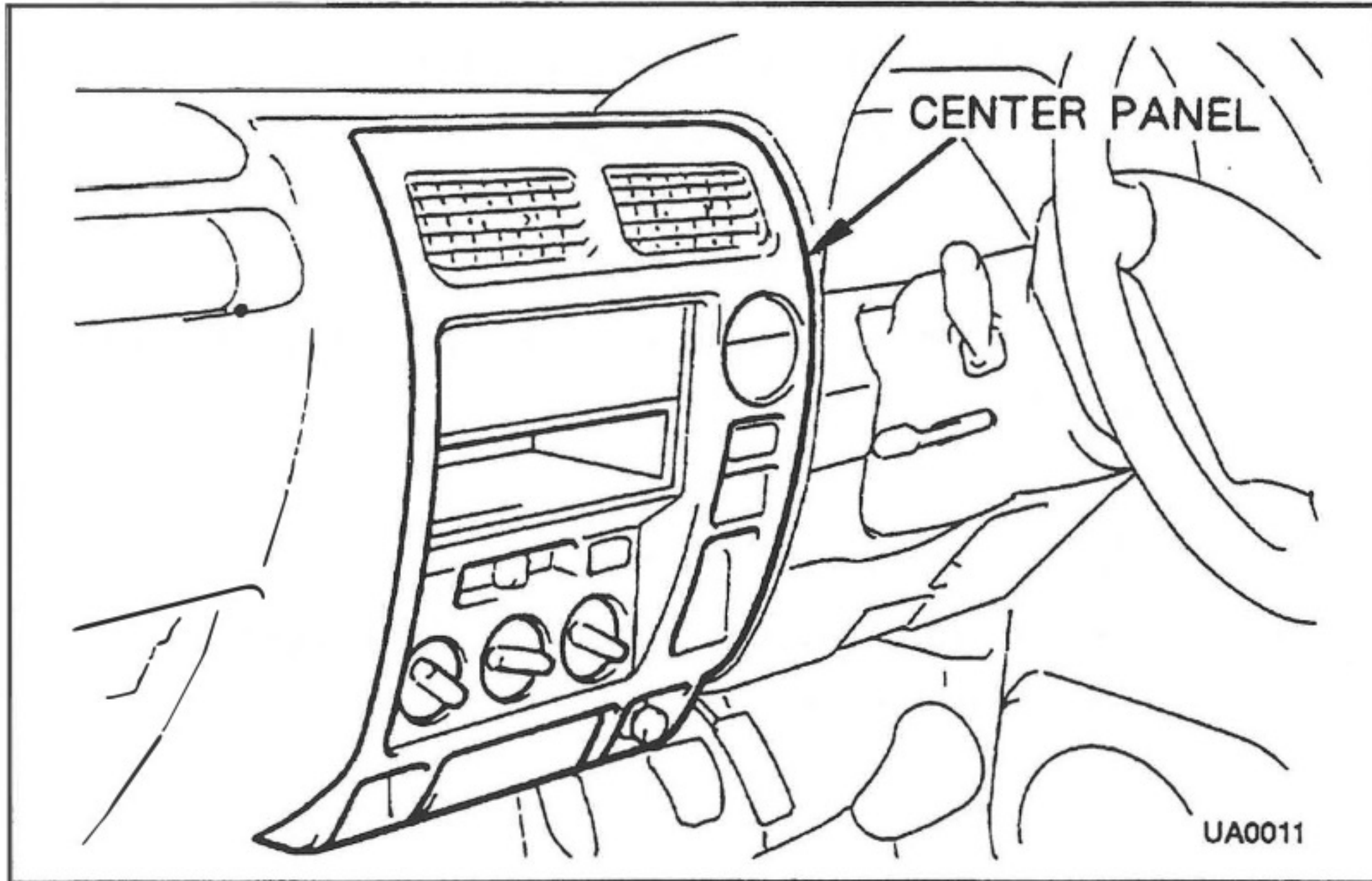

**(4) A/C SWITCH**

- (a) Remove the center panel.

**CAUTION**

Carefully insert a trim removing tool (part no. 09070-20010), in the lower corners of the centre cluster using a gentle twisting action. Release the two lower clips holding the centre cluster onto the dash.

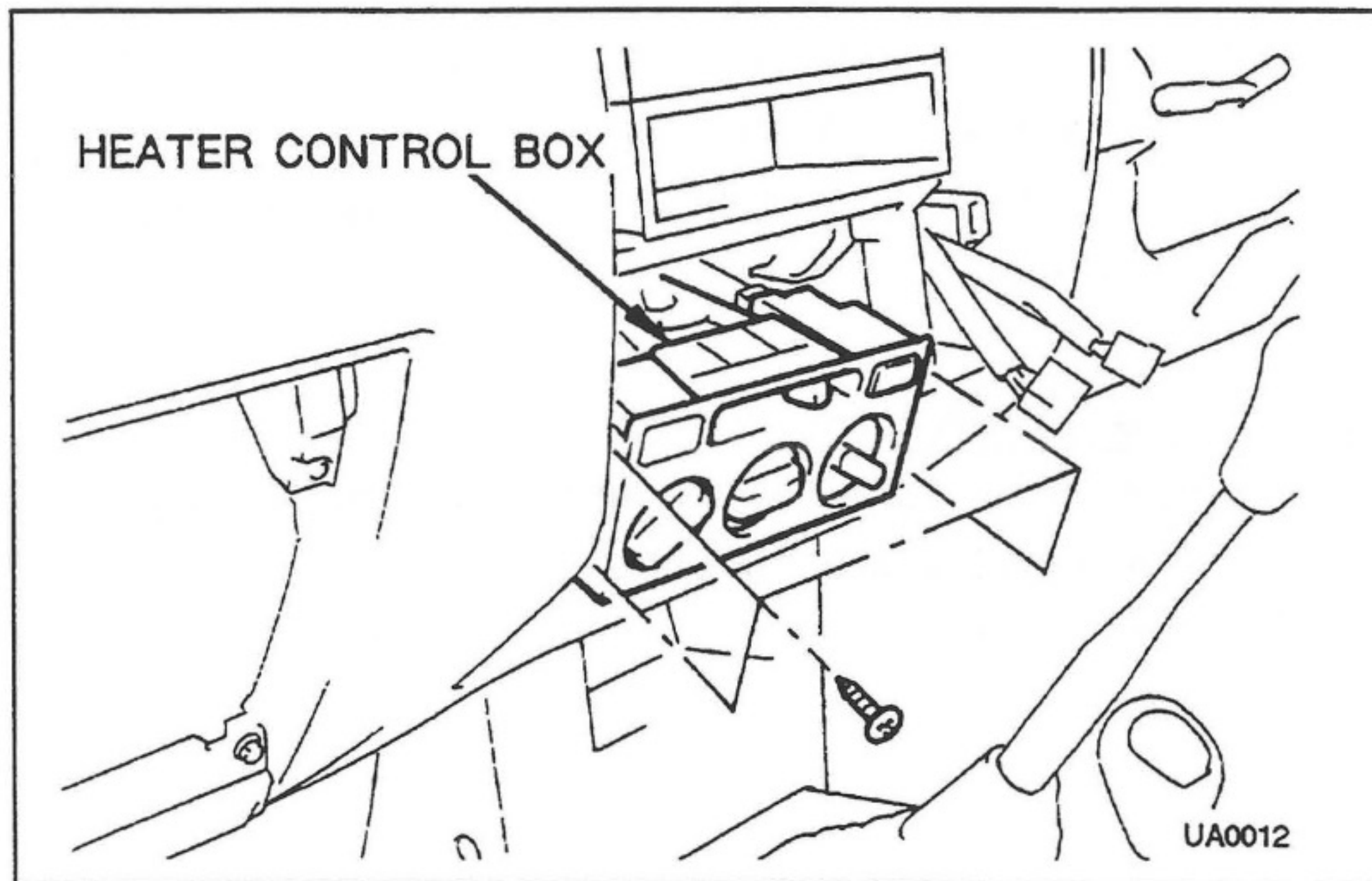

- (b) Remove the heater control box.

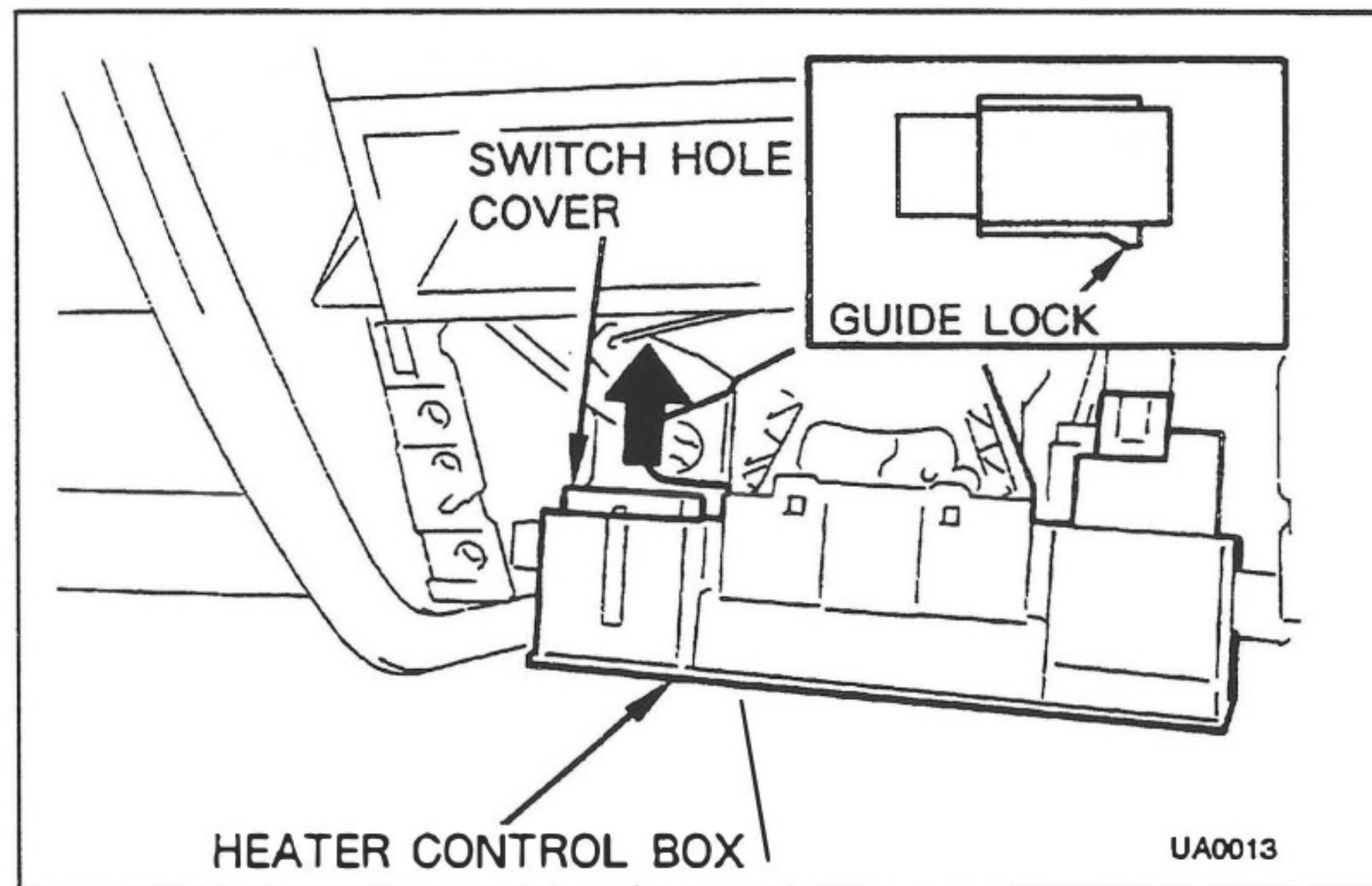

- (c) Remove and discard the switch hole cover.

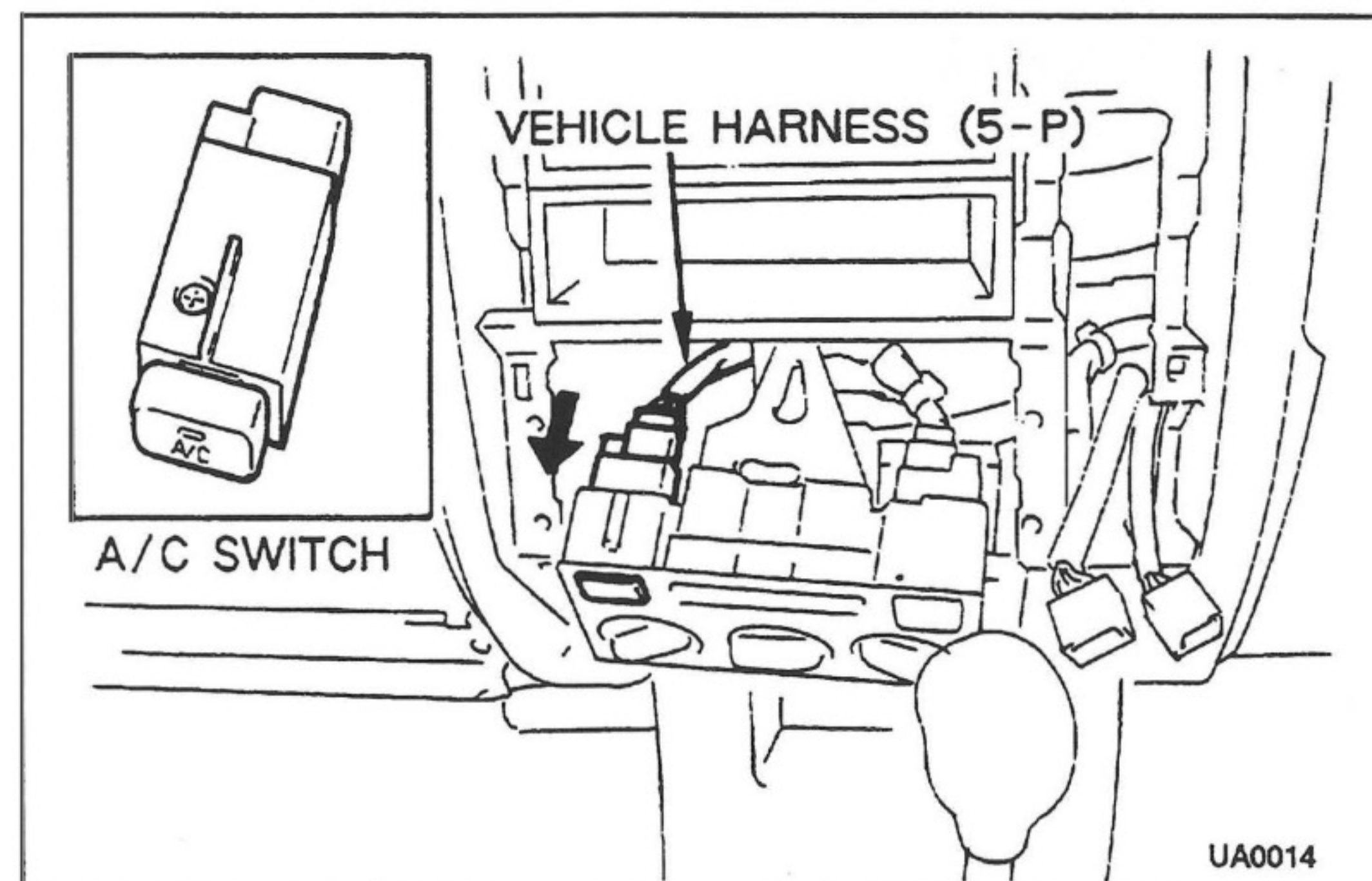

- (d) Insert the A/C switch behind the heater control box.  
 (e) Connect the vehicle harness (5-P) to the A/C switch.

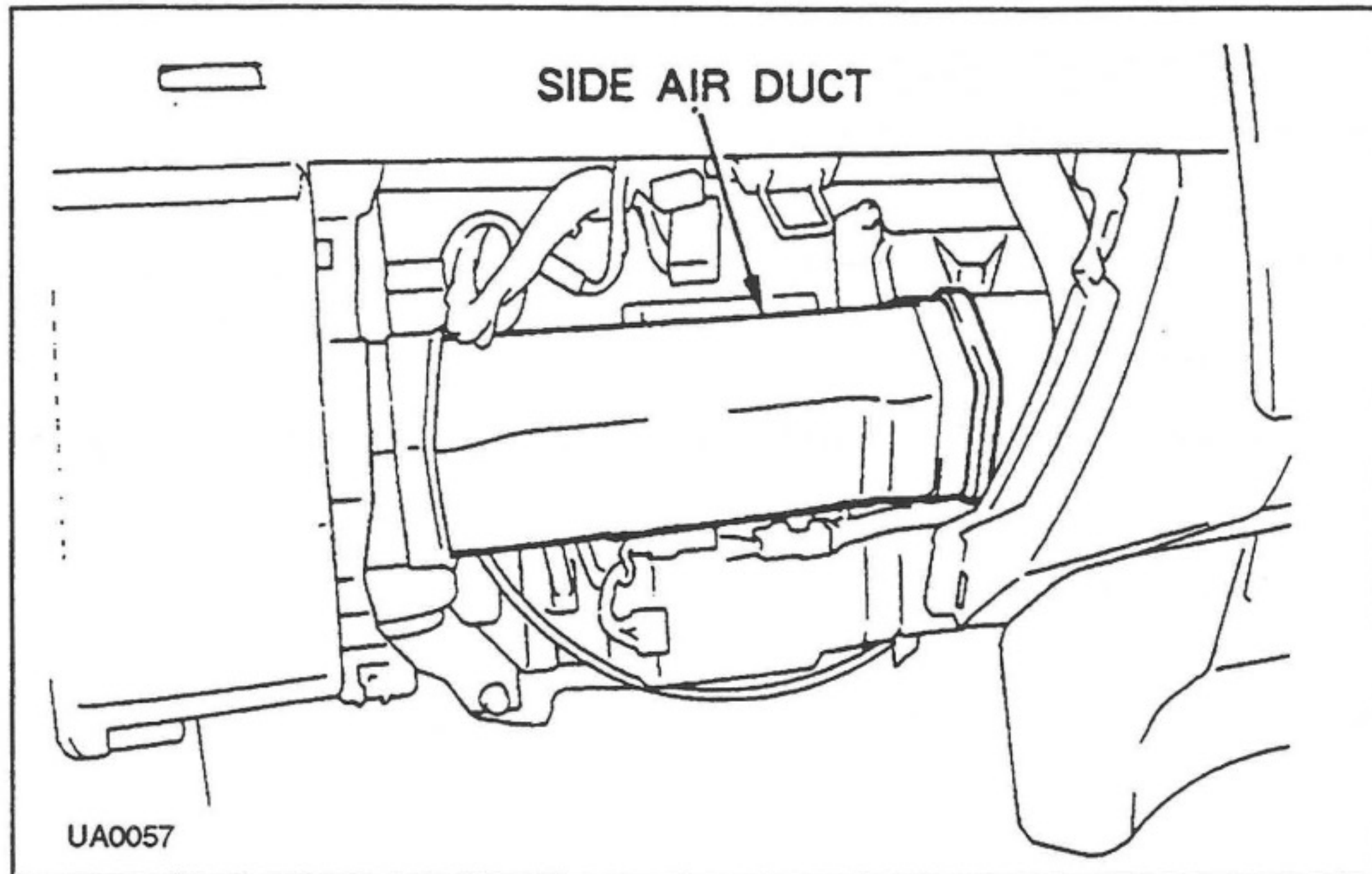

(f) Reinstall the side air duct.

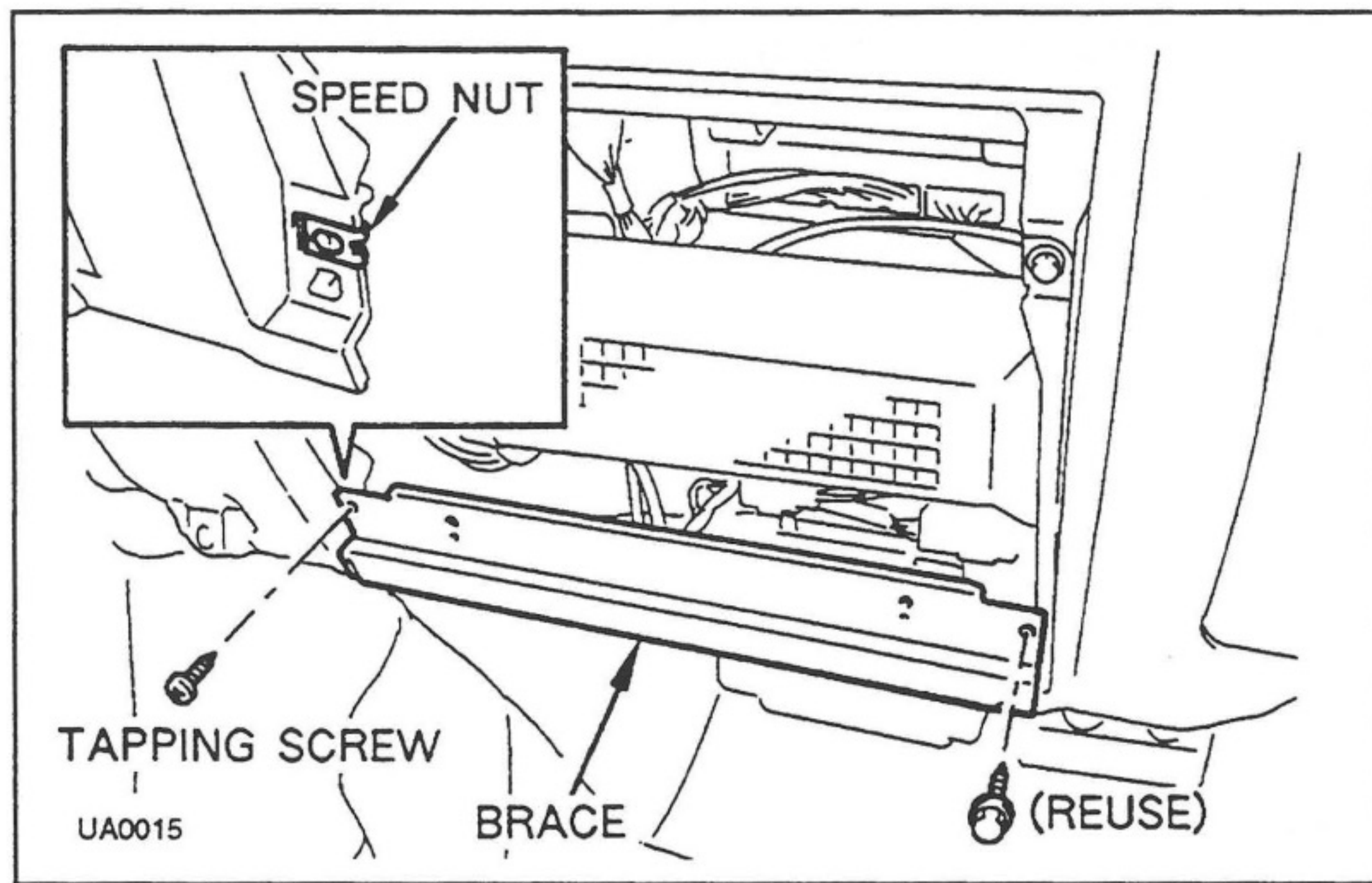

(g) Install the speed nut to the left side of instrument panel edge.

(h) Install the brace using tapping screw and the original tapping screw.

**NOTE**

*Choose and install the braces with the same color of the instrument panel.*

**(5) REINSTALLATION OF PARTS**

Reinstall the following temporarily removed parts.

## 2-2 INSTALLATION INSIDE ENGINE COMPARTMENT

### !CAUTION

1. Before starting installation, remove the negative cable from the battery.
2. Before making any hoses and tubes connections, apply a few drops of compressor oil to the seat of O-ring and coupling nuts.
3. When tightening and loosening the fittings, use two wrenches for support.
4. Ensure fender covers are in position.

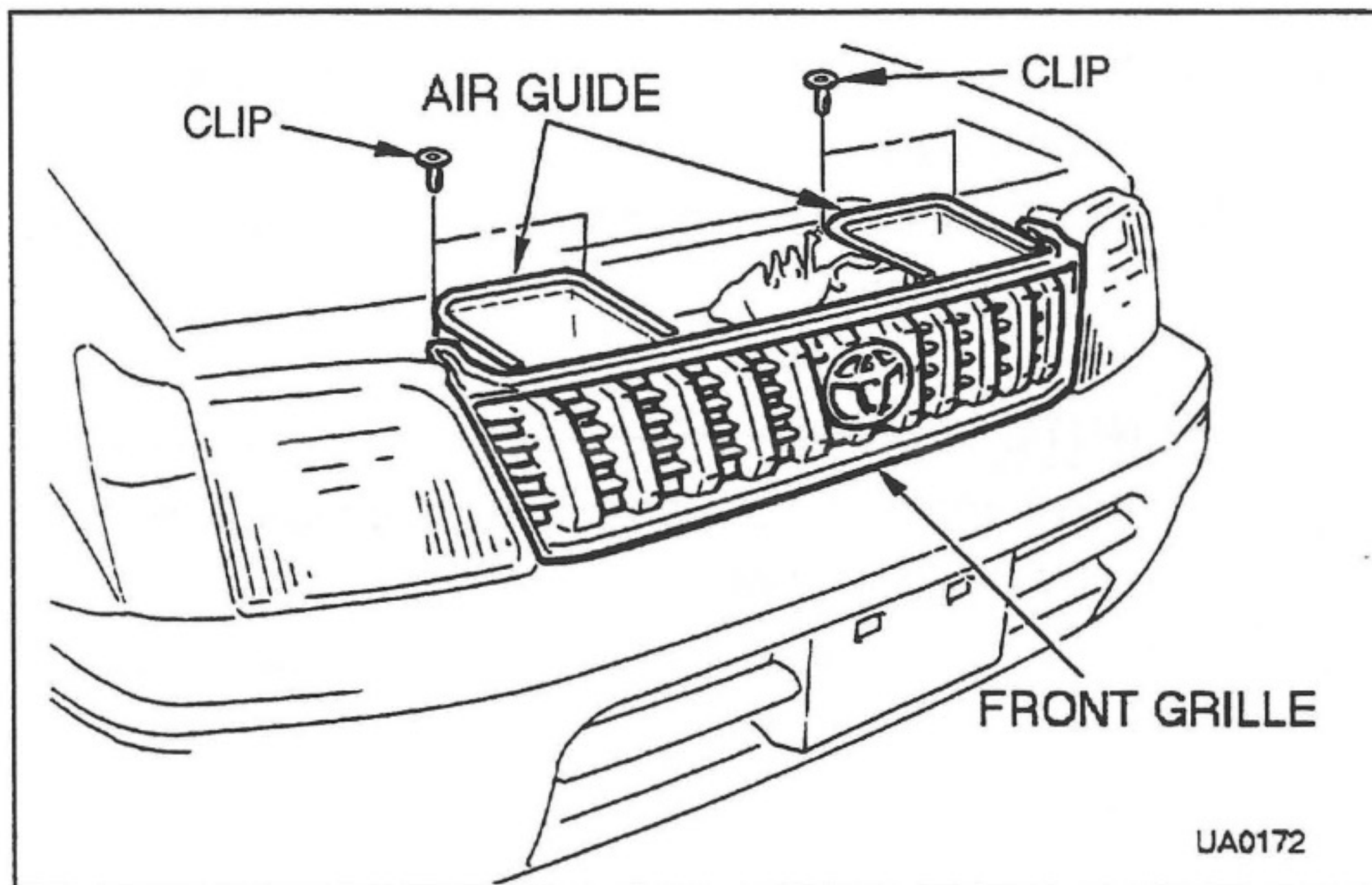

### (1) REMOVAL OF PARTS

- (a) Air guide
- (b) Front grille

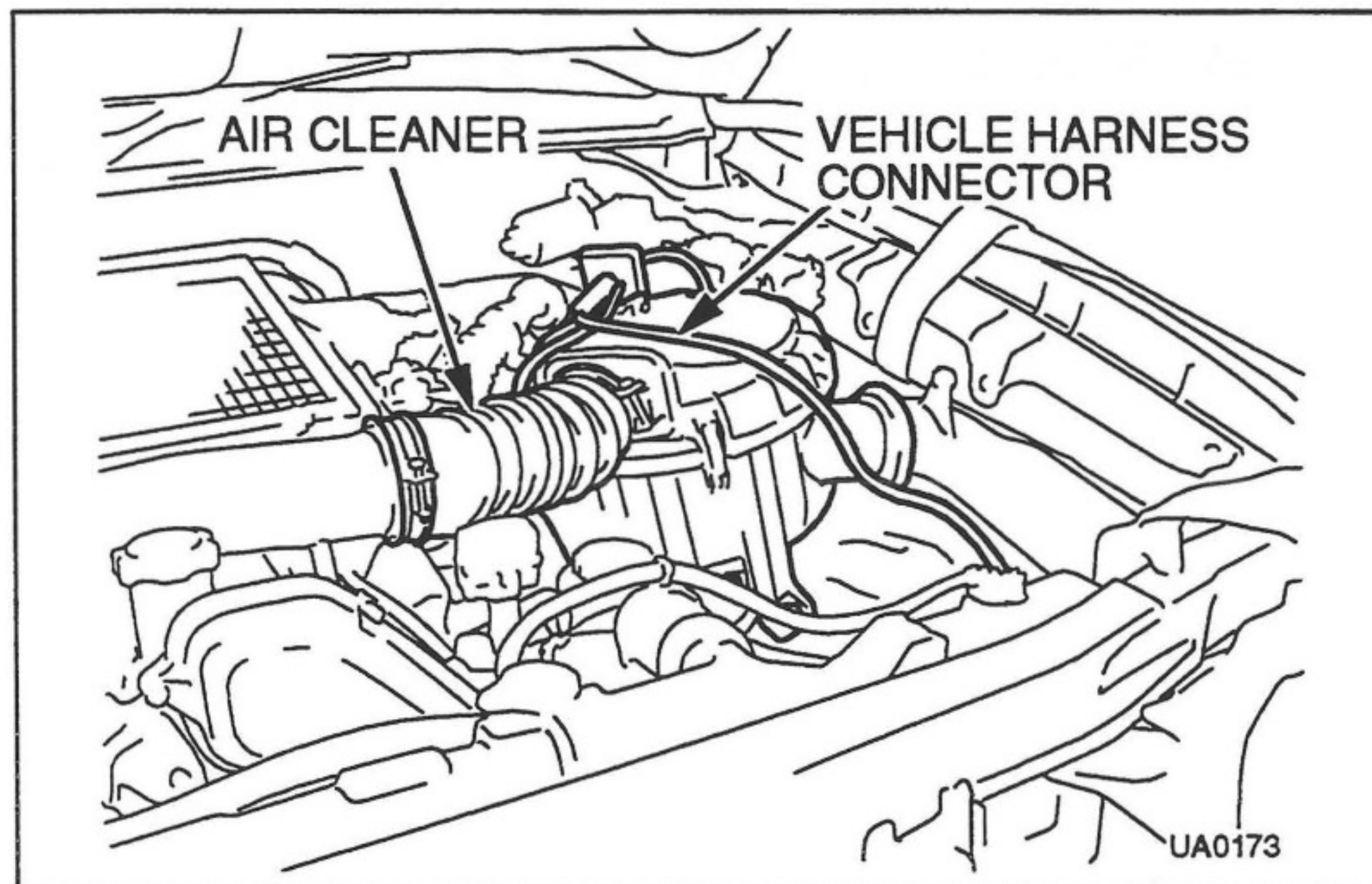

- (c) Vehicle harness connector
- (d) Air cleaner

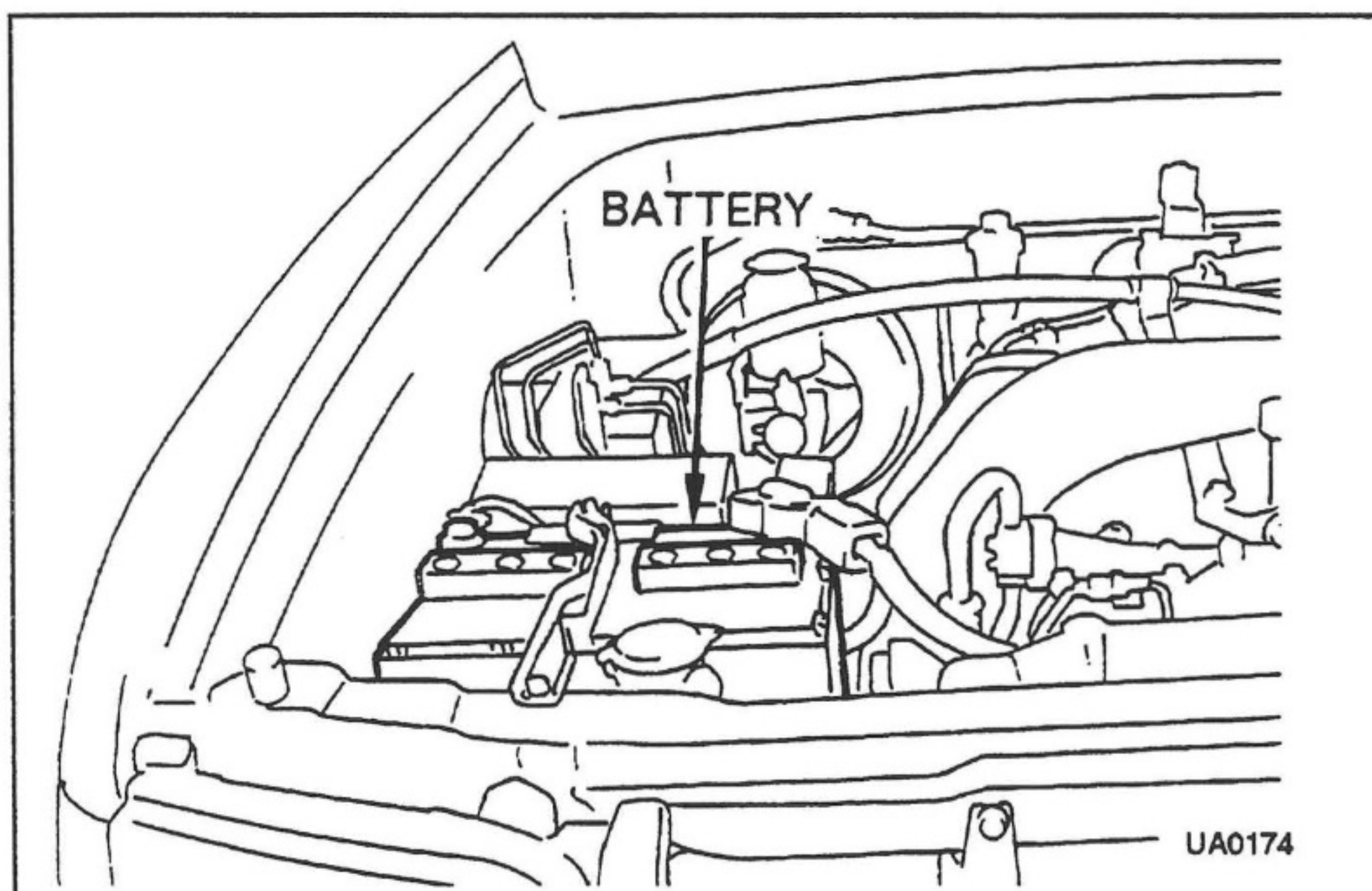

- (e) Battery and Battery carrier (Right side)

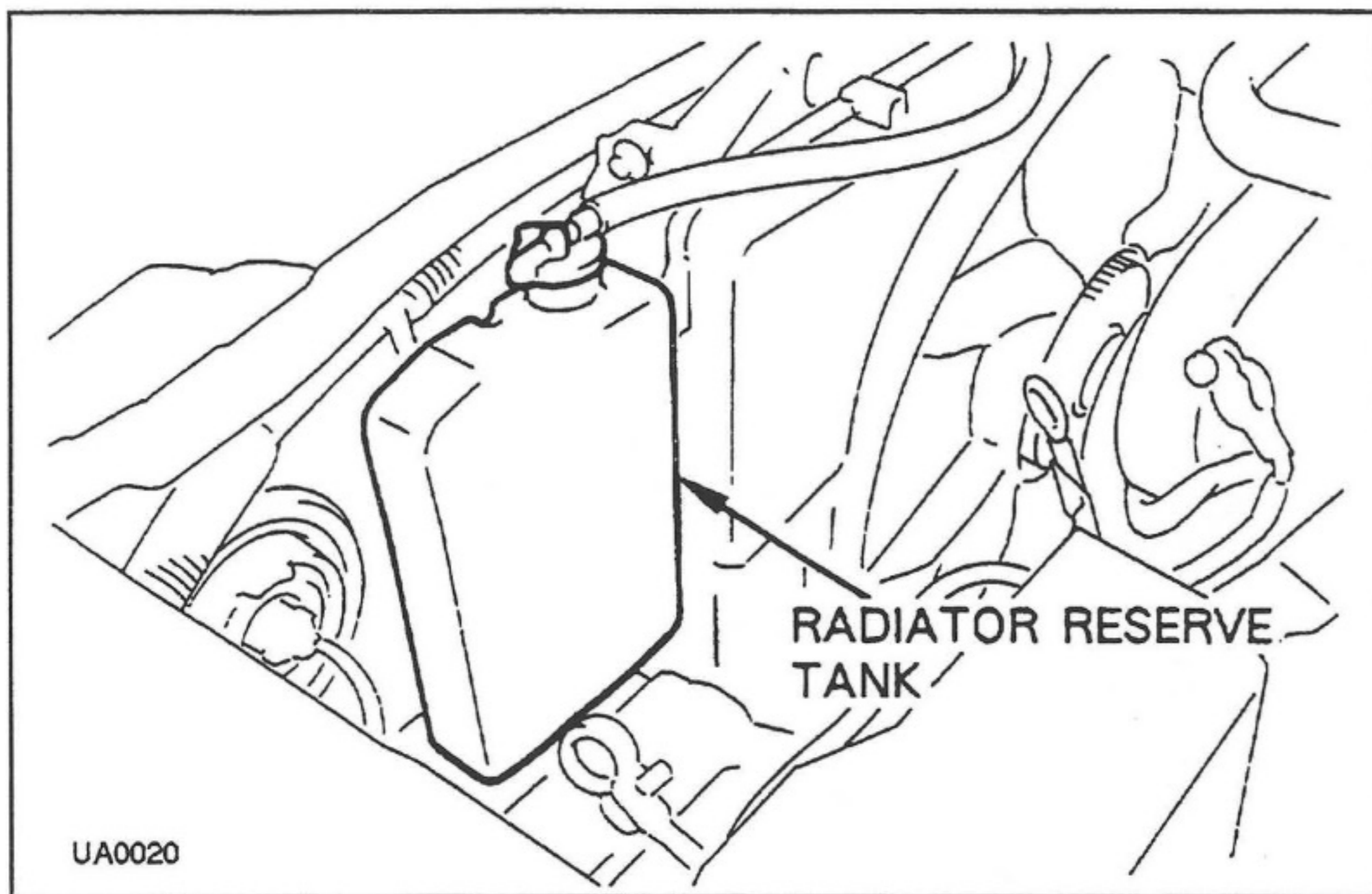

(f) Radiator reserve tank

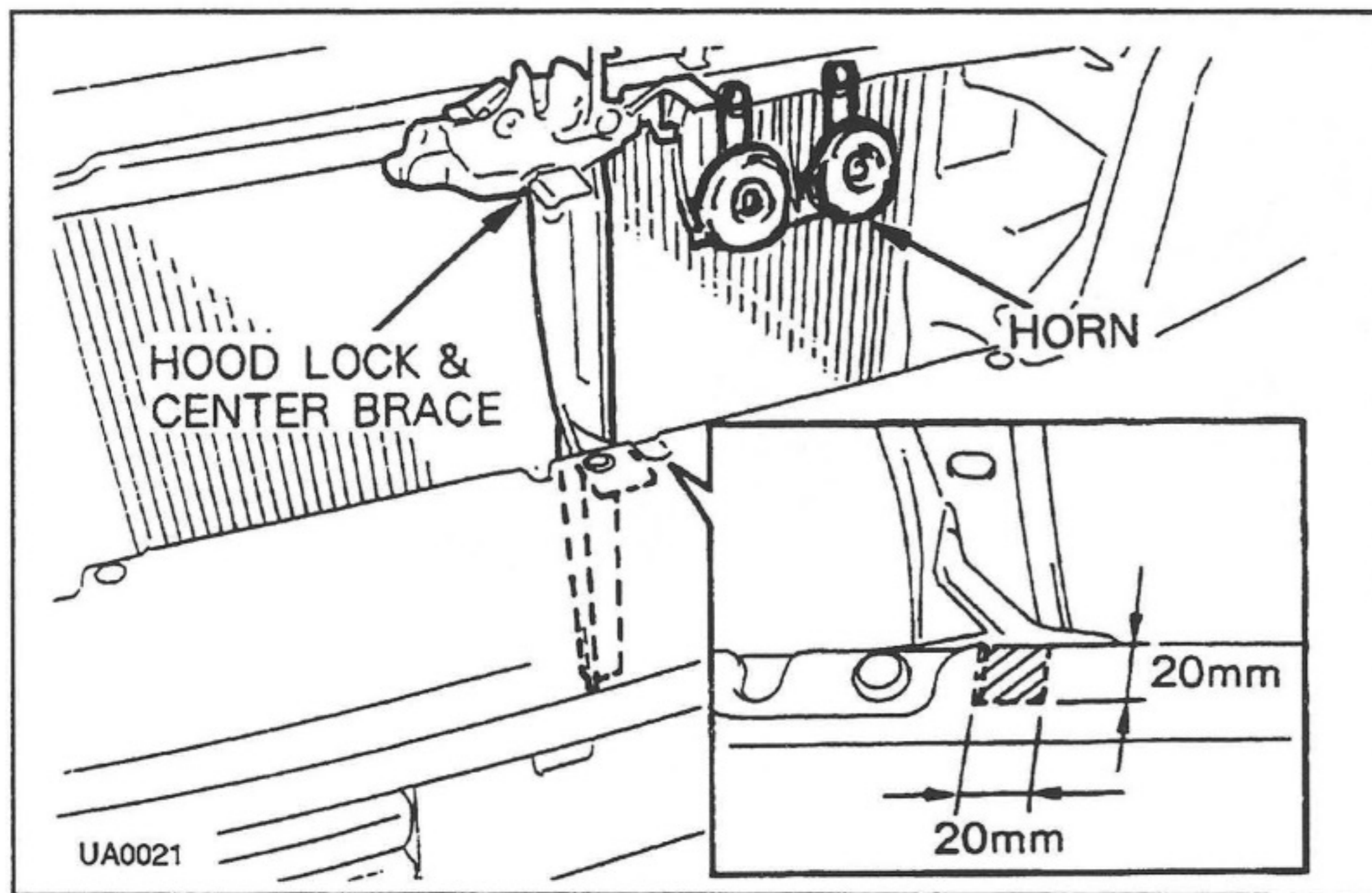

(g) Hood lock and Center brace

**NOTE**

*Cut out the bumper at 20mm x 20mm before removing the center brace.*

(h) Horns

(2) COMPRESSOR

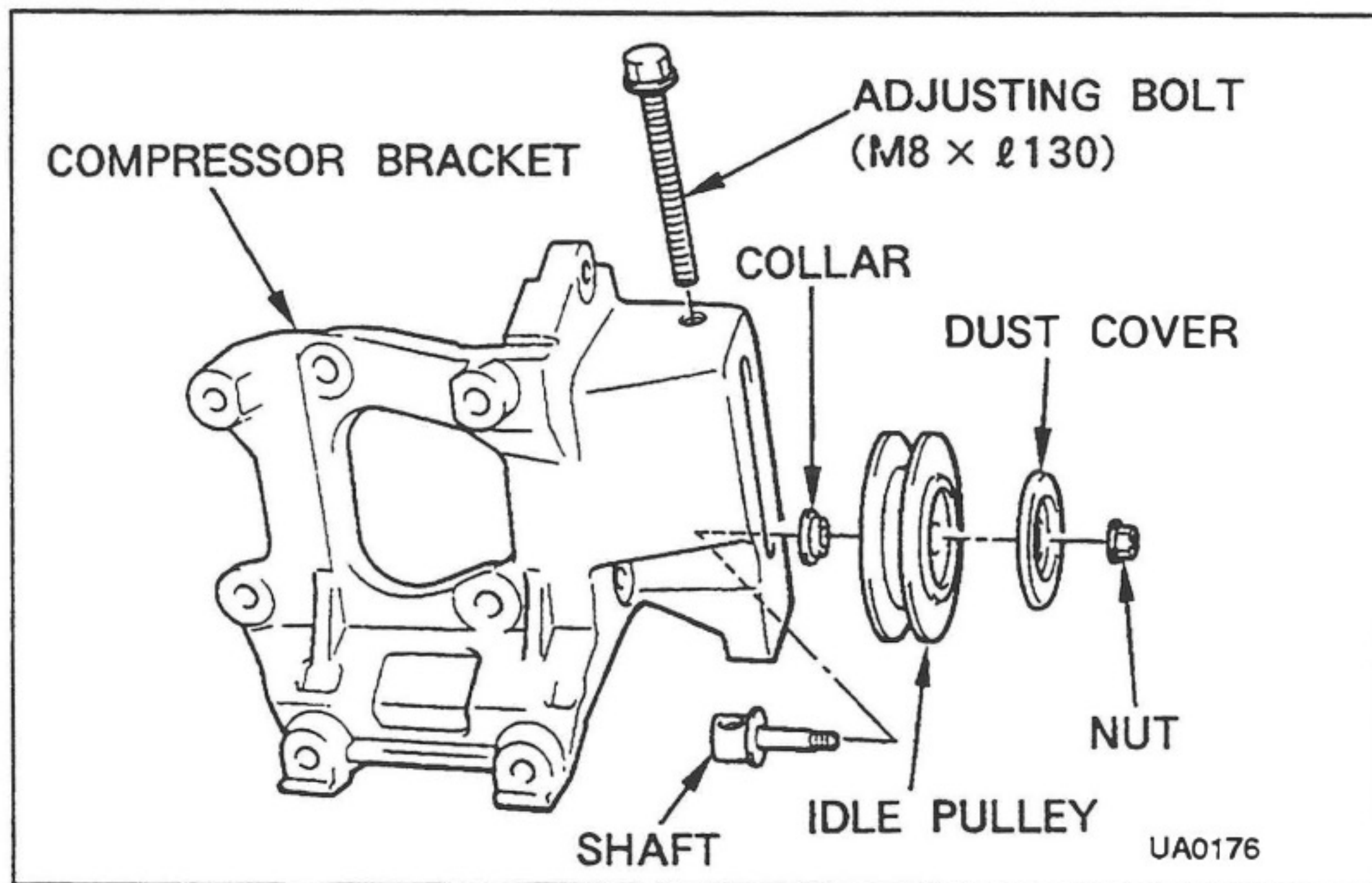
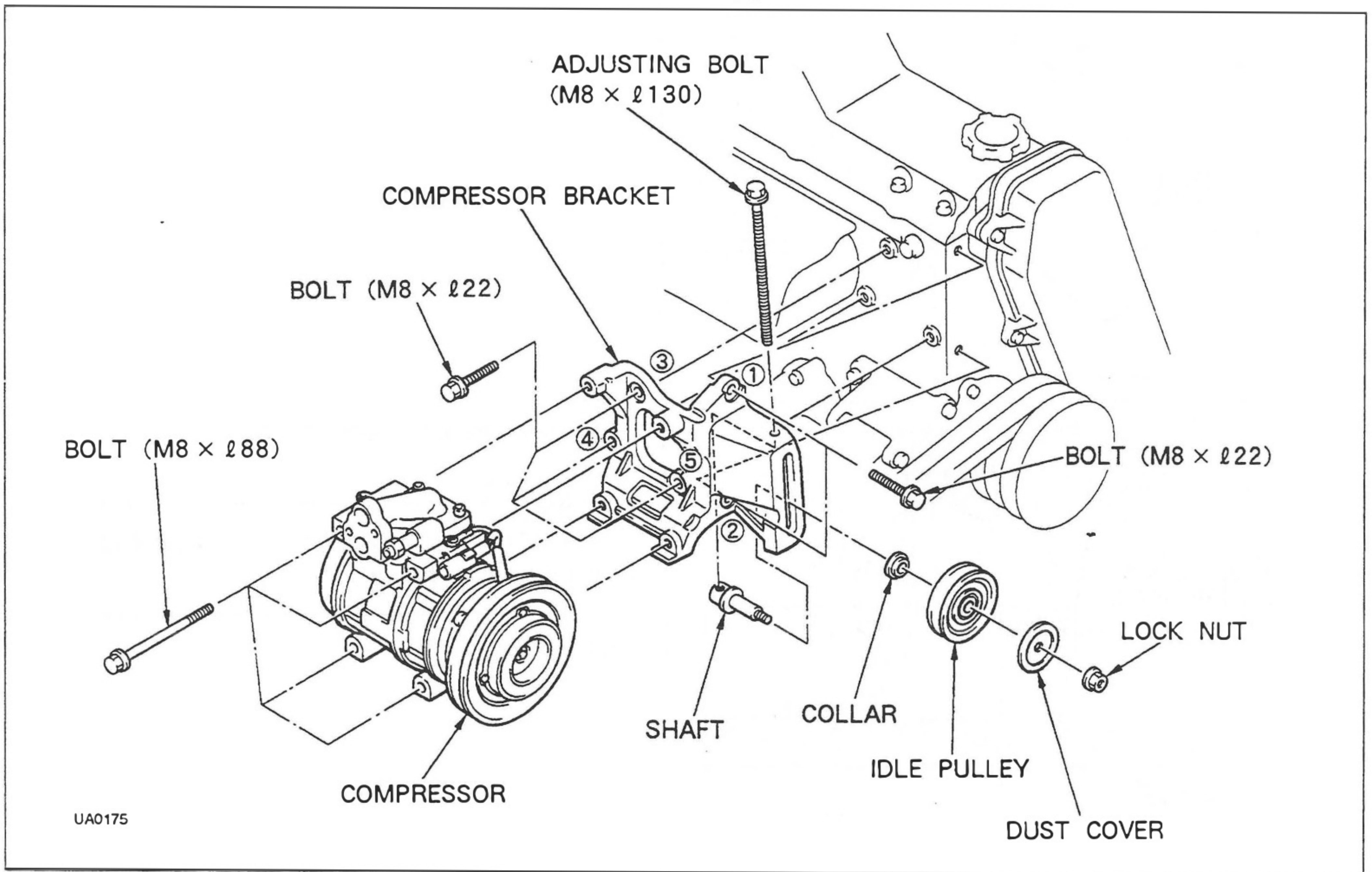

(a) Assemble the idle pulley assy to the compressor bracket.

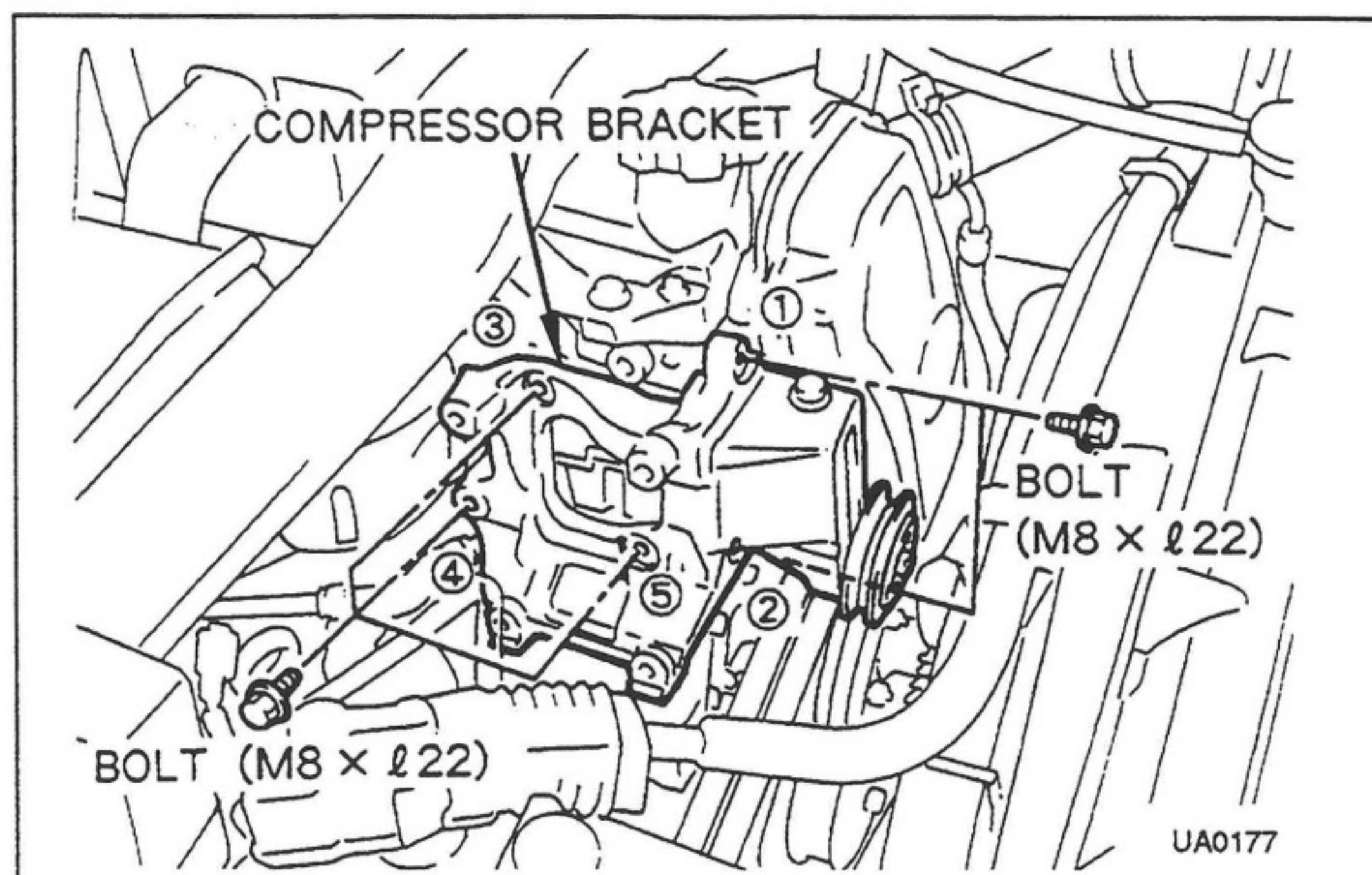

(b) Install the compressor bracket to the engine block using five bolts.

Tightening Order : ① → ② → ③ → ④ → ⑤

Tightening Torque

24.5 N•m (250 kgf•cm, 18.1 ft•lbf)

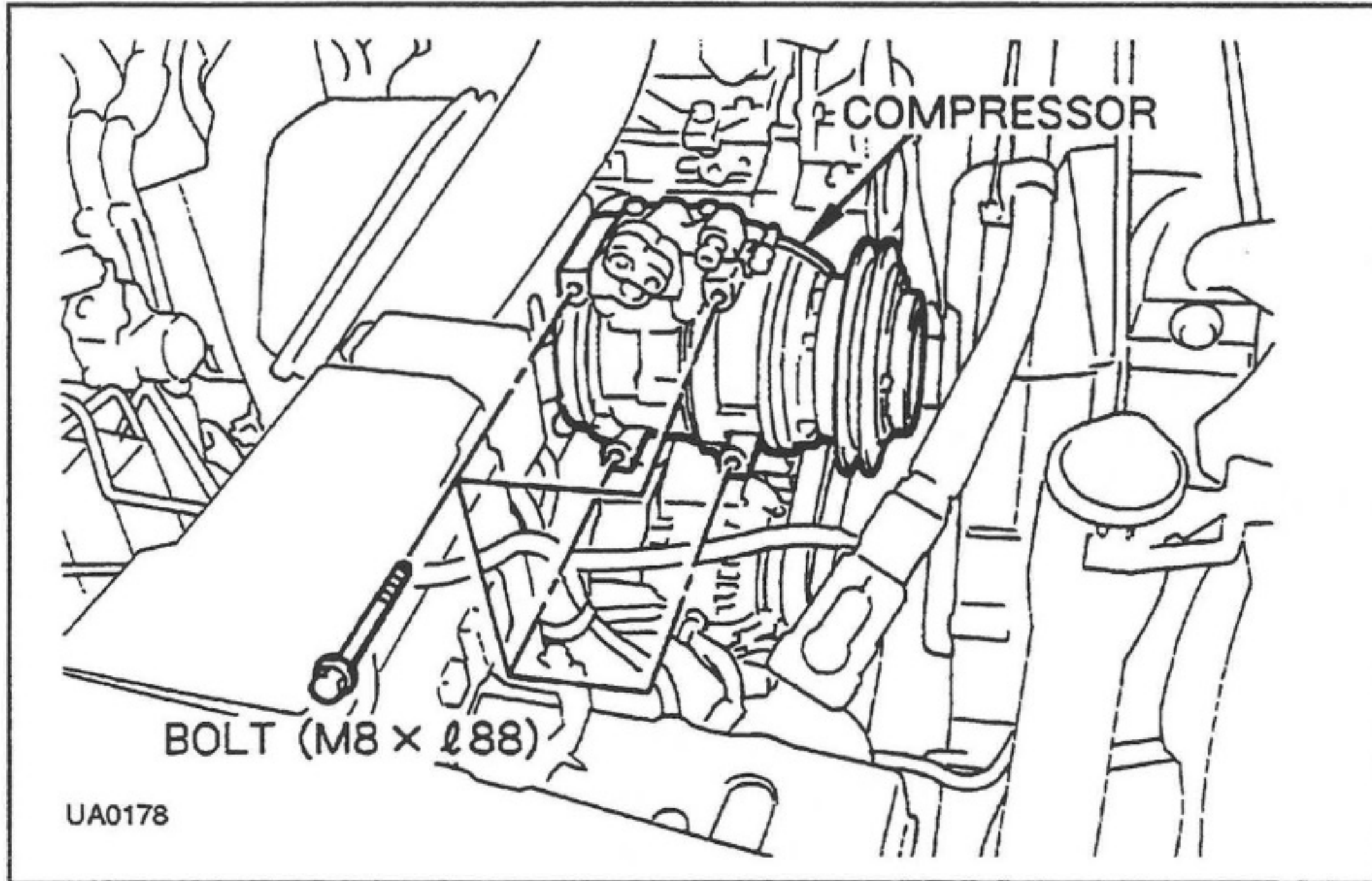

- (c) Install the compressor to the compressor bracket using four bolts.

**CAUTION**

Place and turn the bolts fully by hand then tightening to the required torque.

**Tightening Torque**

24.5 N•m (250 kgf•cm, 18.1 ft•lbf)

- (d) Install the compressor drive belt.

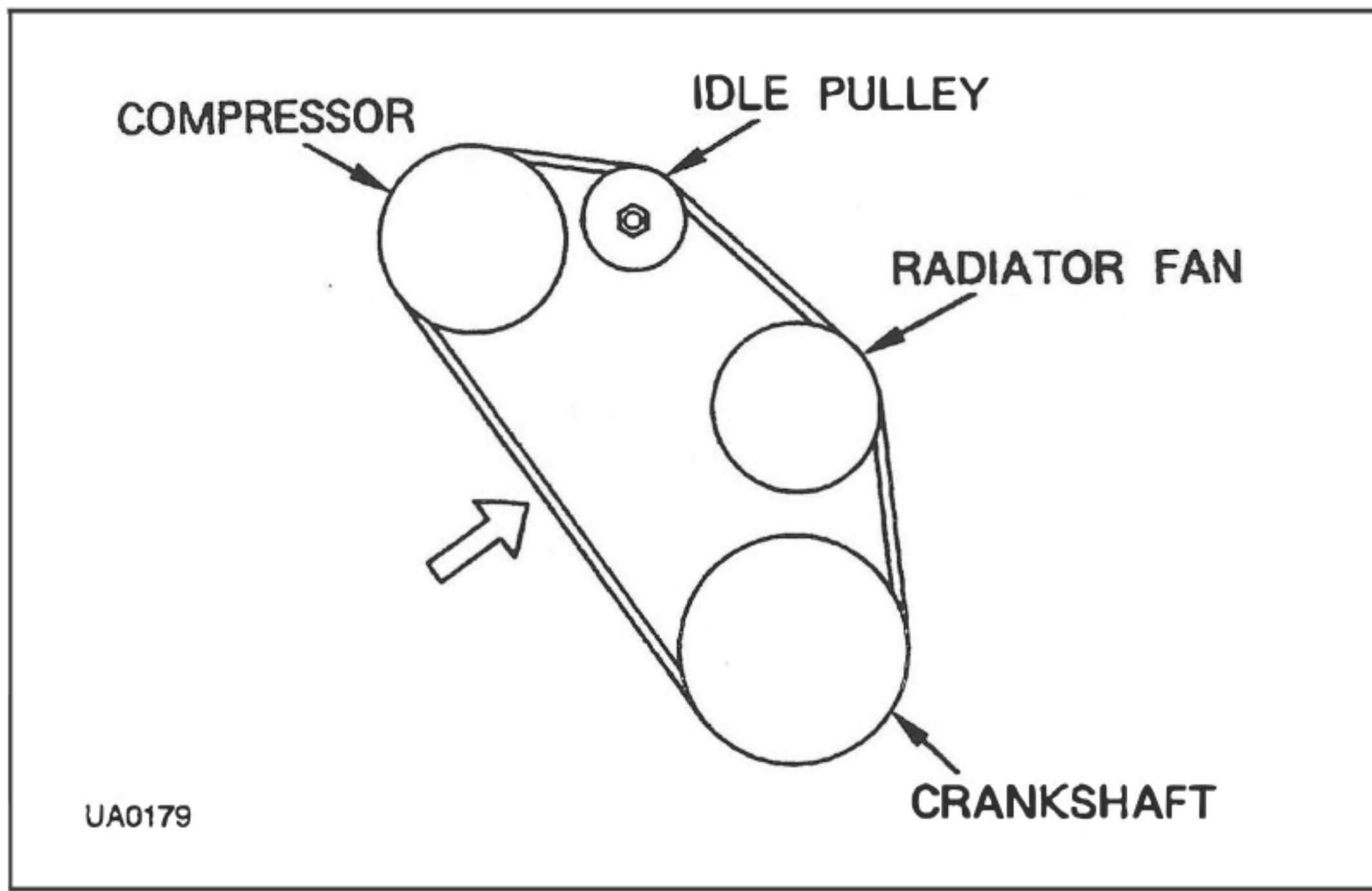

- (e) Adjust the belt tension using the adjusting bolt, check the belt tension using the belt tension gauge.

|           | Belt tension using the belt tension gauge | Belt deflection at 10 kgf (22 lbf) force |
|-----------|---|--|
| New belt  | 50 + 12 kgf<br>(110 + 26 lbf)             | 13 - 15 mm                               |
| Used belt | 30 + 10 kgf<br>(66 + 22 lbf)              | 15 -21 mm                                |

**NOTE**

Make sure to readjust the belt tension, after installing the air conditioning.

- (f) Tighten the idle pulley lock nut.

**Tightening Torque**

39.2 N•m (400 kgf•cm, 28.9 ft•lbf)

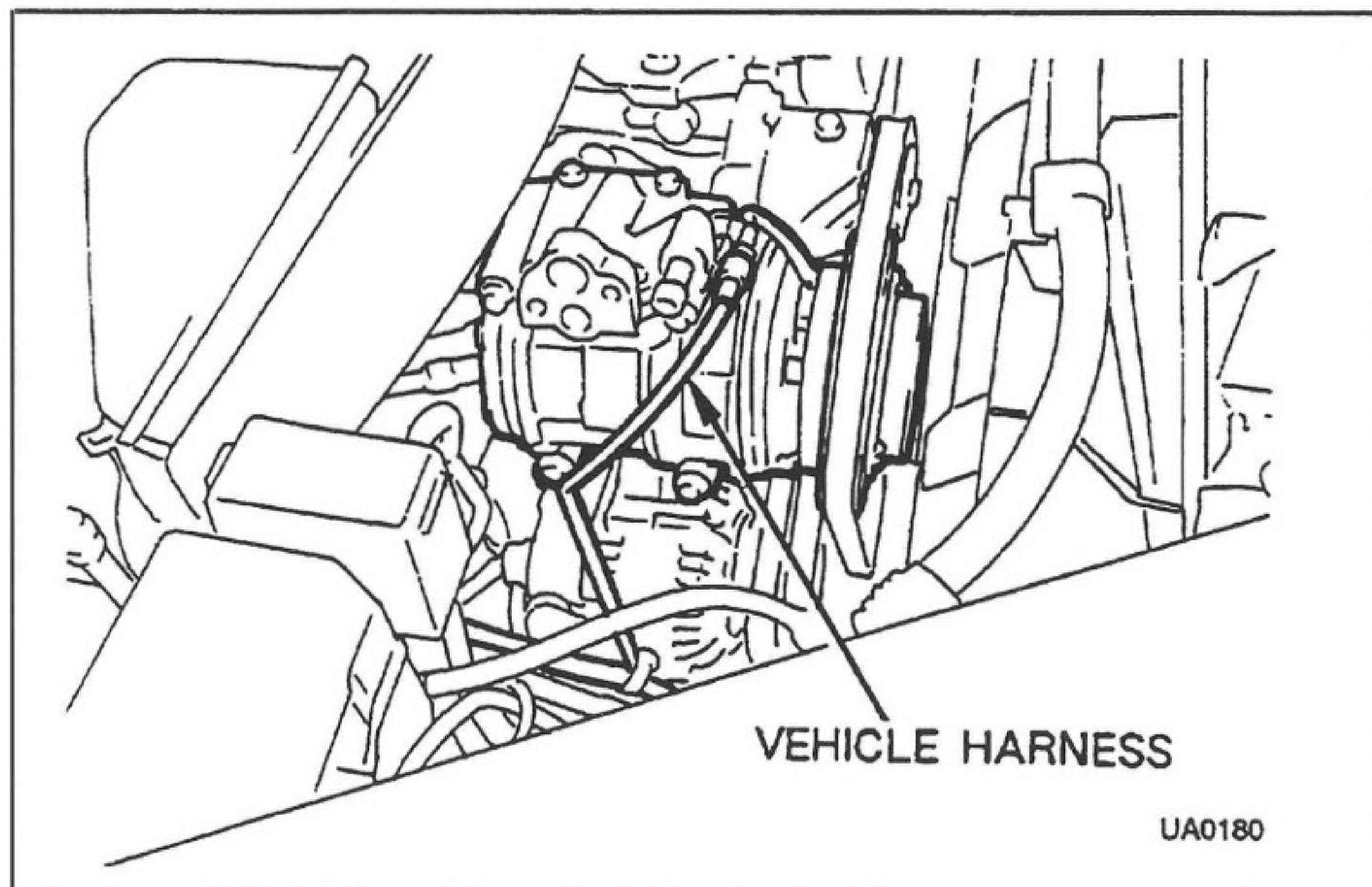

- (g) Connect the vehicle harness to the mg.clutch connector.

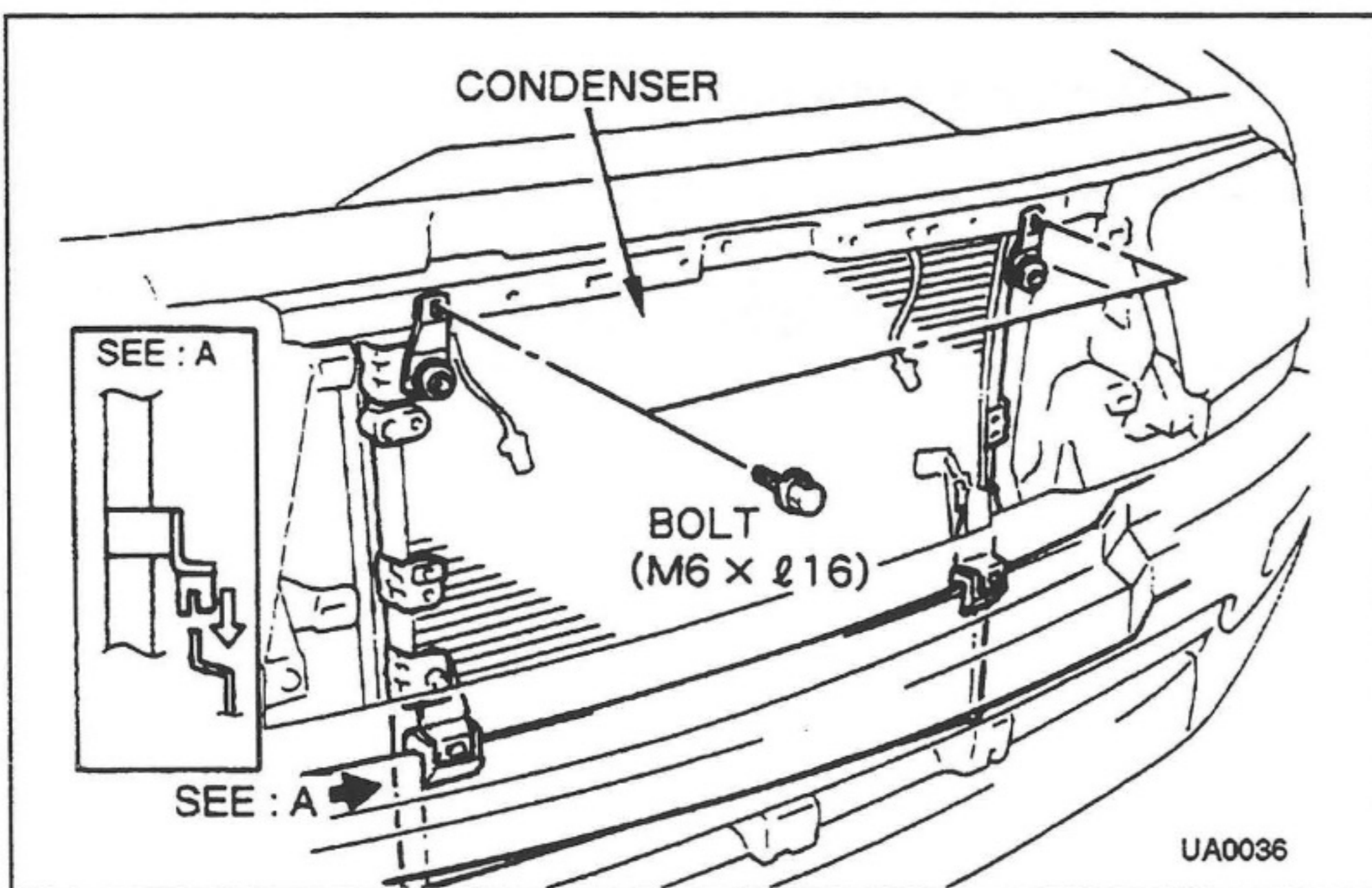
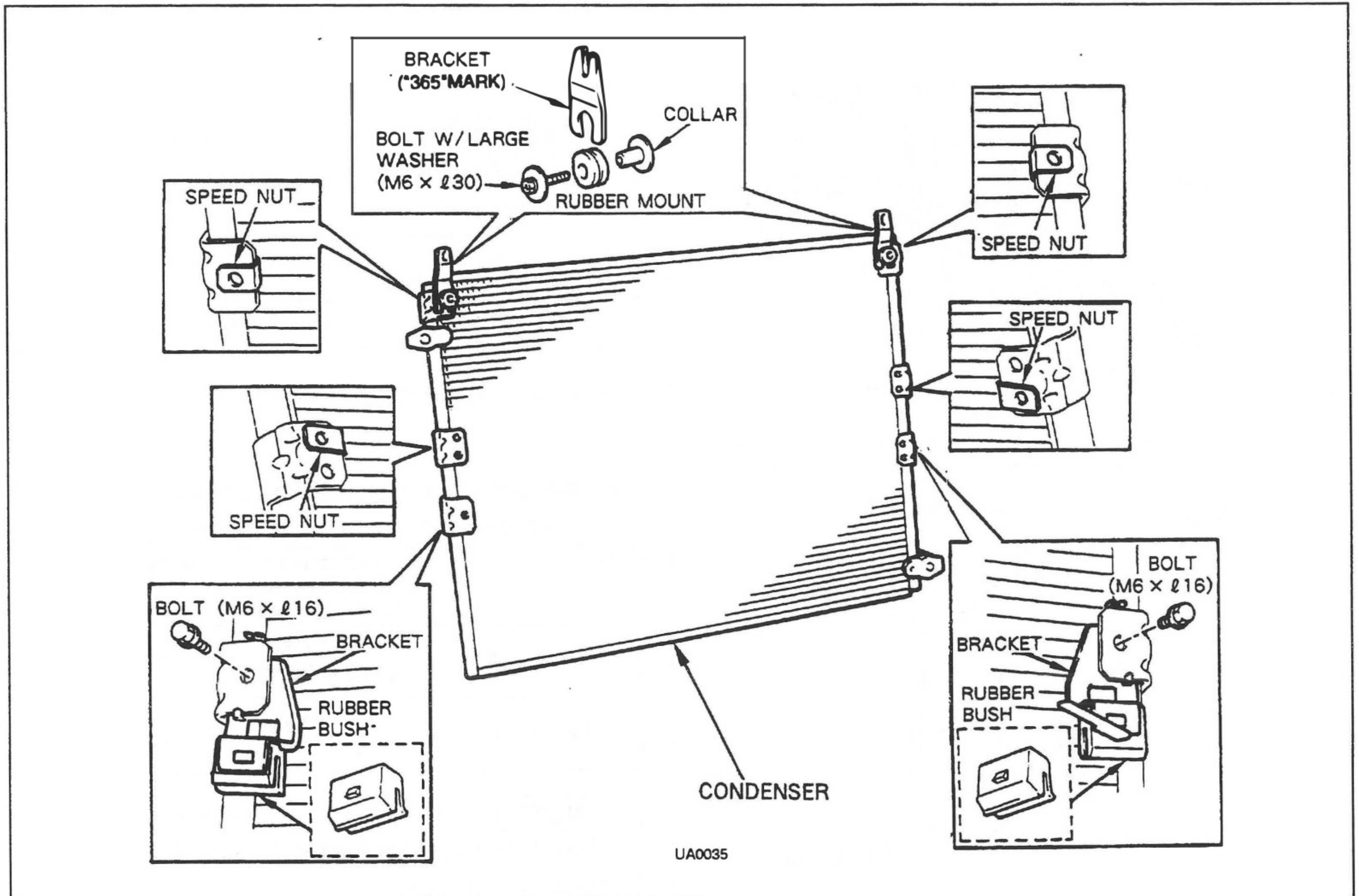

### (3) CONDENSER

- (a) Assemble the two brackets, two rubber bush, two collars, two rubber mounts, two brackets and speed nuts to the condenser using four bolts.
- (b) Install the condenser in front of the radiator support upper using two bolts.

#### CAUTION

*Ensure horn wiring does not get caught between the condenser and radiator.*

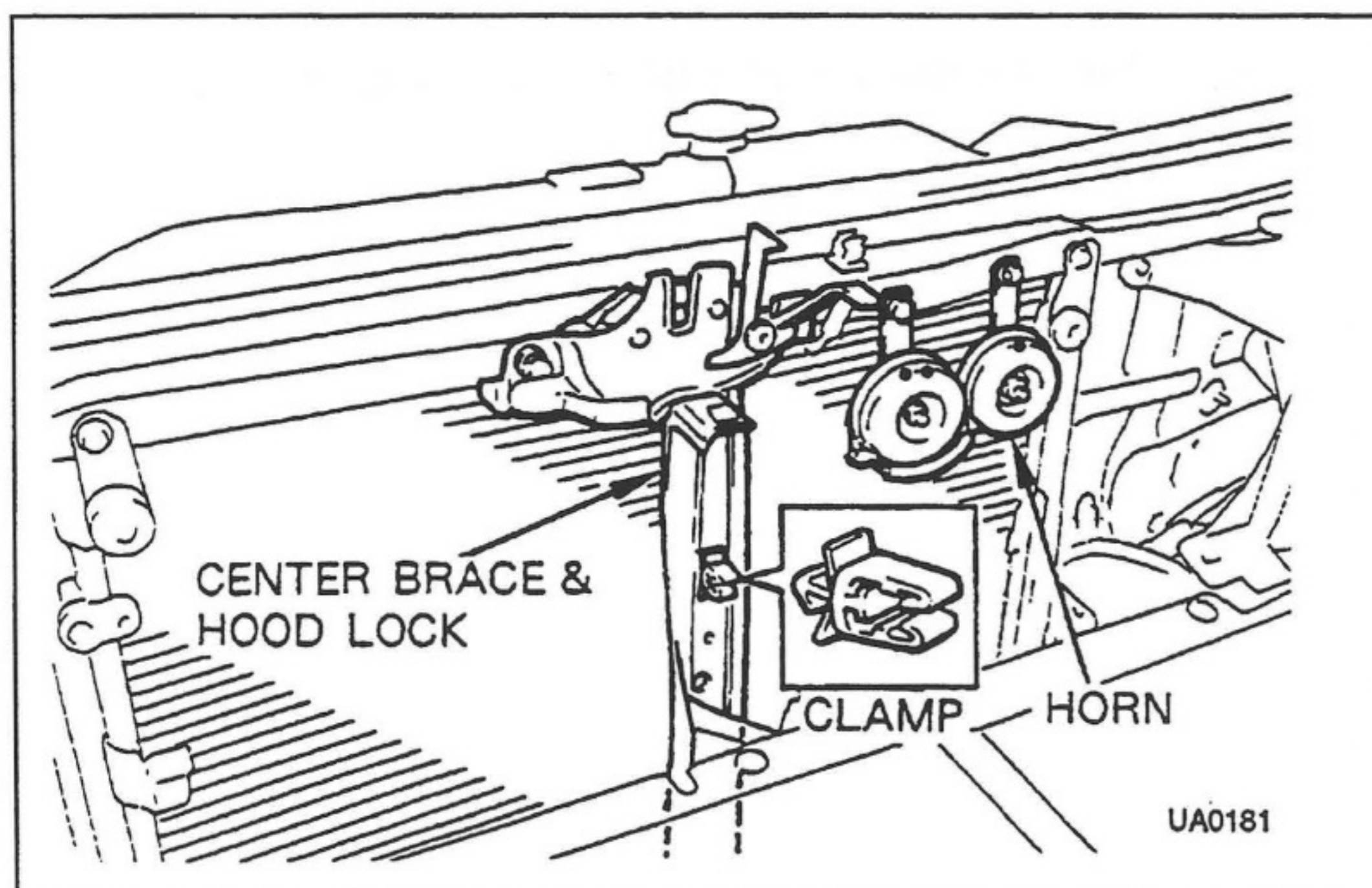

- (c) Reinstall the center brace, hood lock and horns.
- (d) Install the clamp to the center brace.

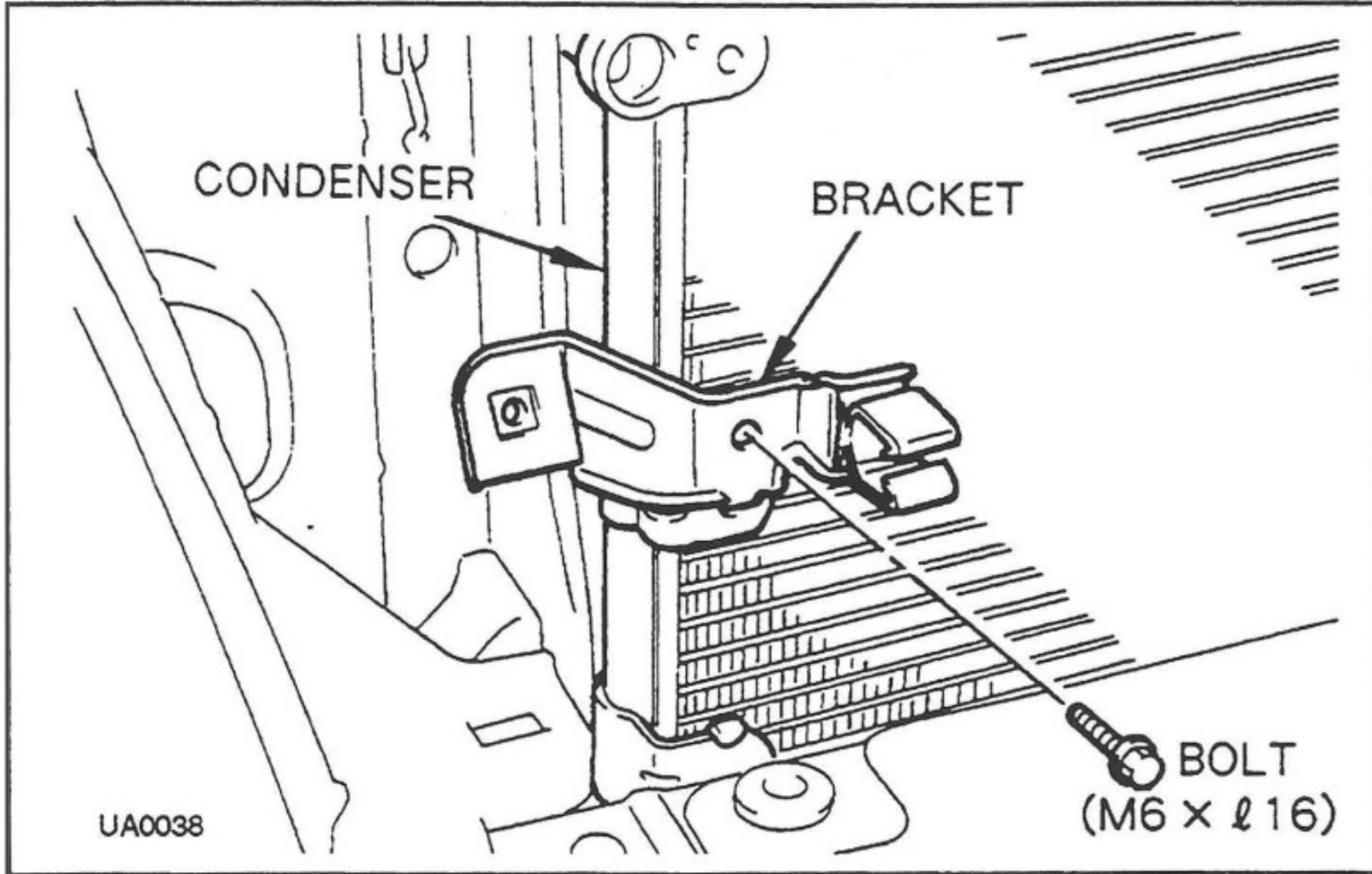

(e) Install the bracket to the condenser using a bolt.

### PIPING LAYOUT

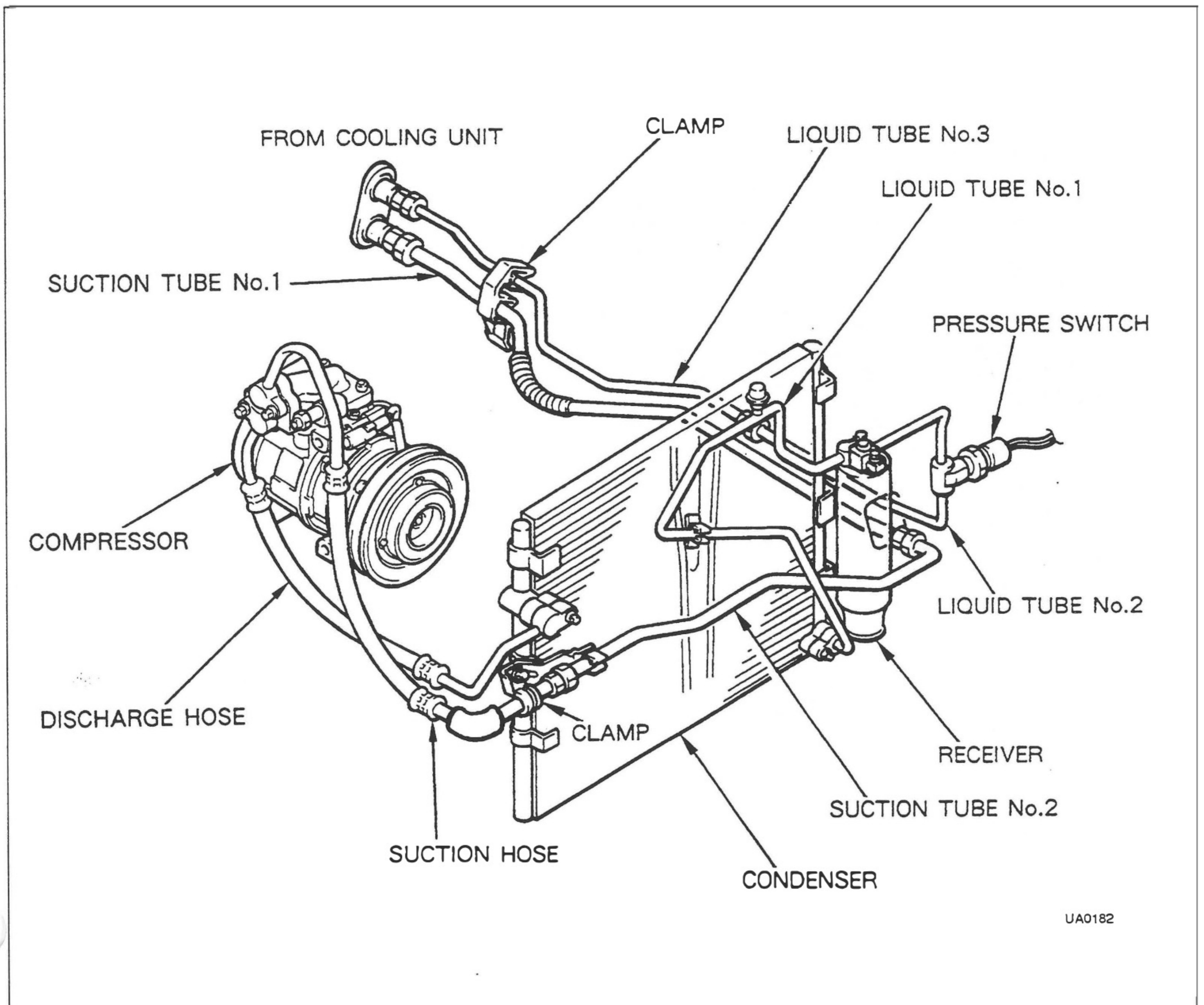

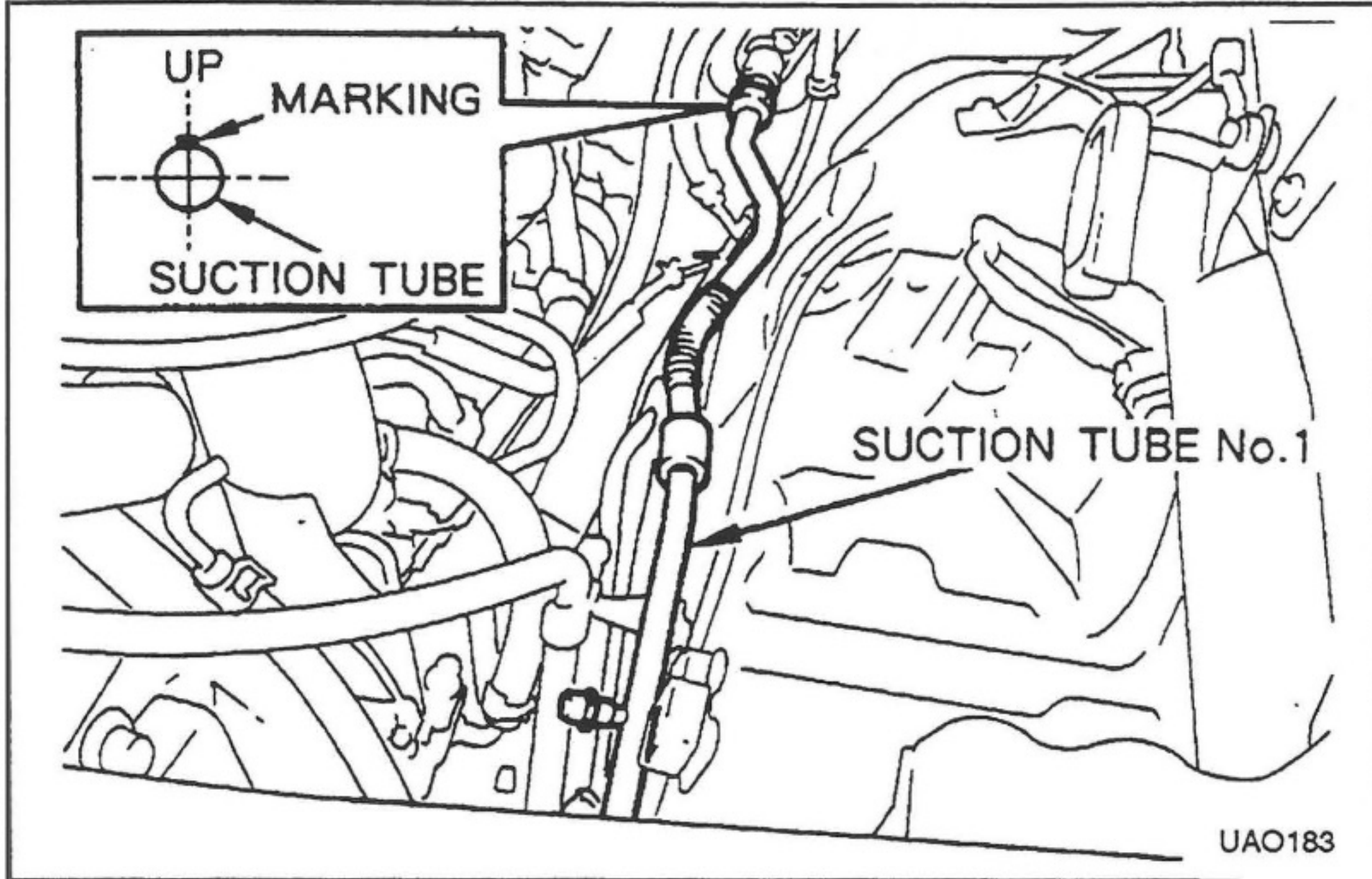

**(4) SUCTION TUBE**

(a) Route and connect the suction tube No.1 as shown.

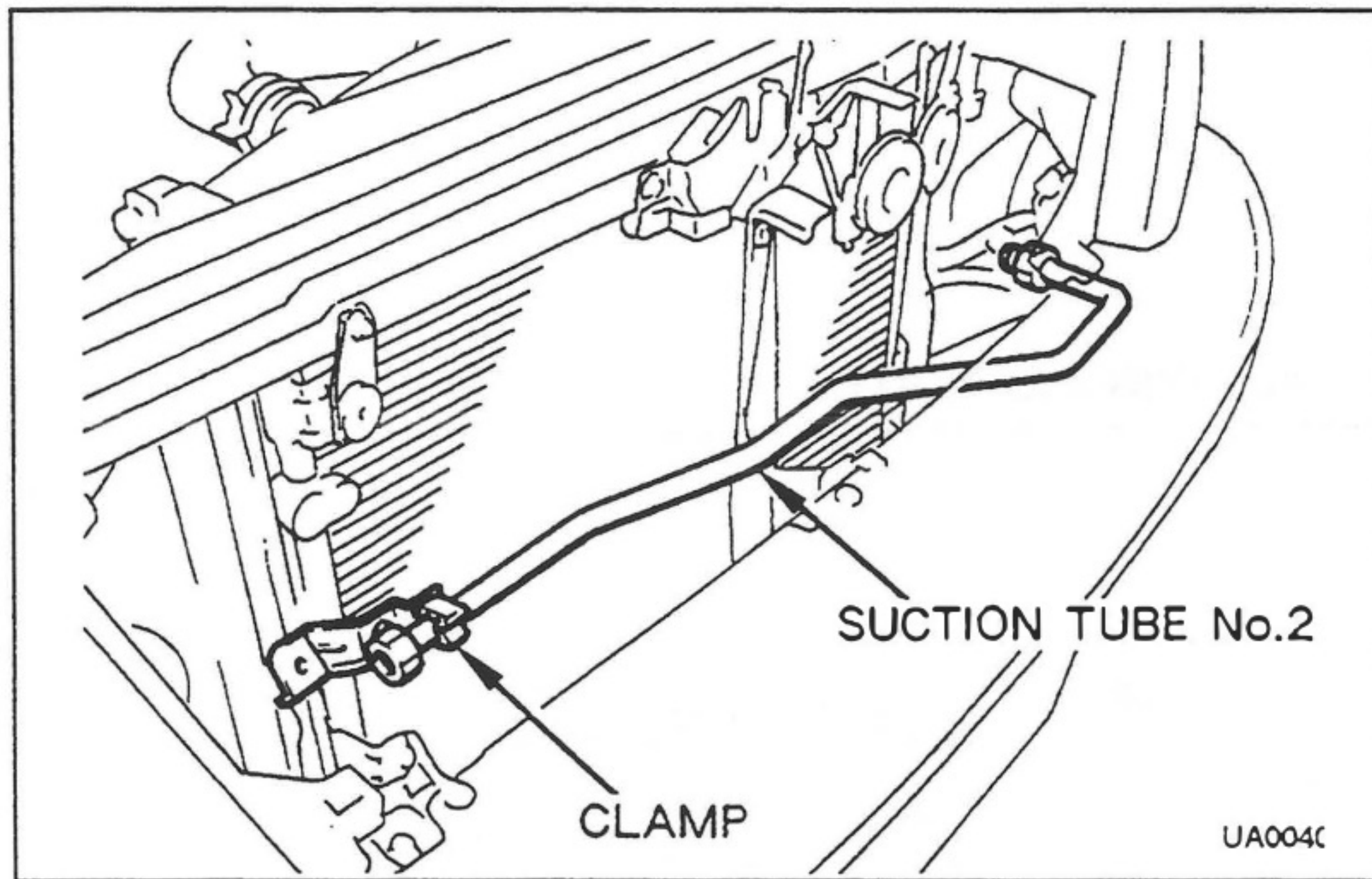

(b) Route and connect the suction tube No.2 as shown.

(c) Fasten the suction tube No.2 to the clamp.

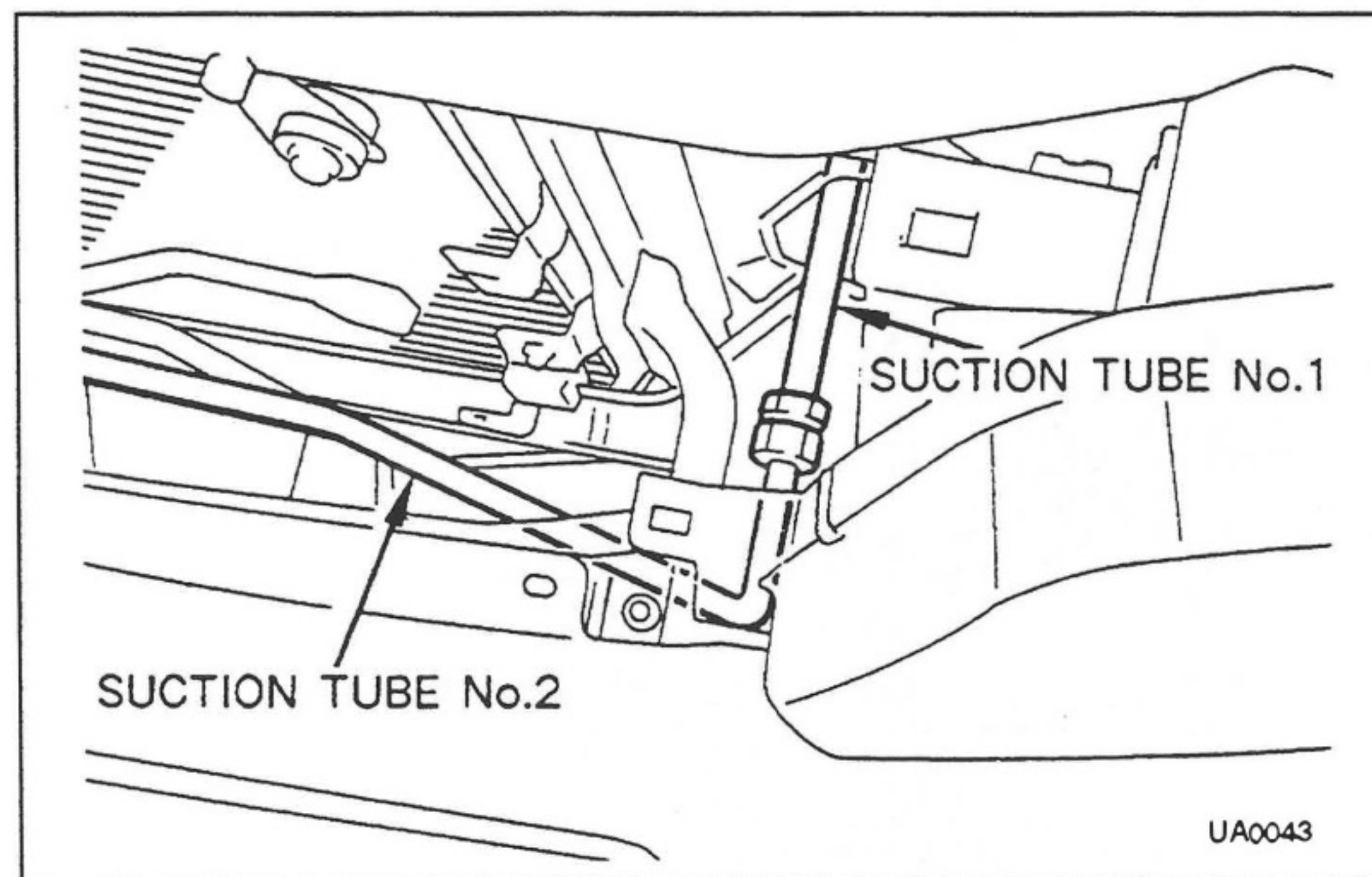

(d) Connect the suction tube No.1 and No.2.

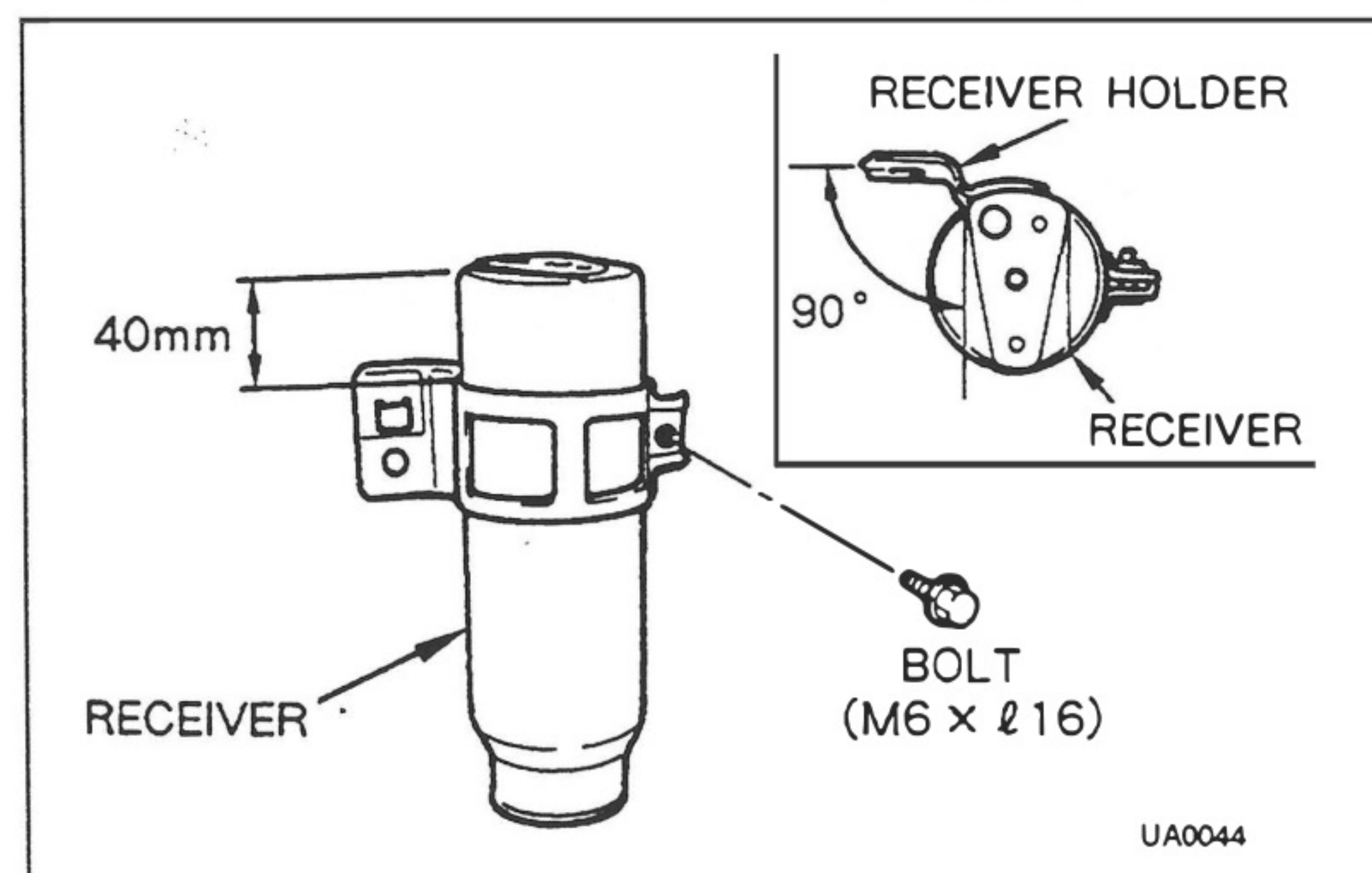

**(5) RECEIVER**

(a) Temporarily install the receiver to the receiver holder using a bolt.

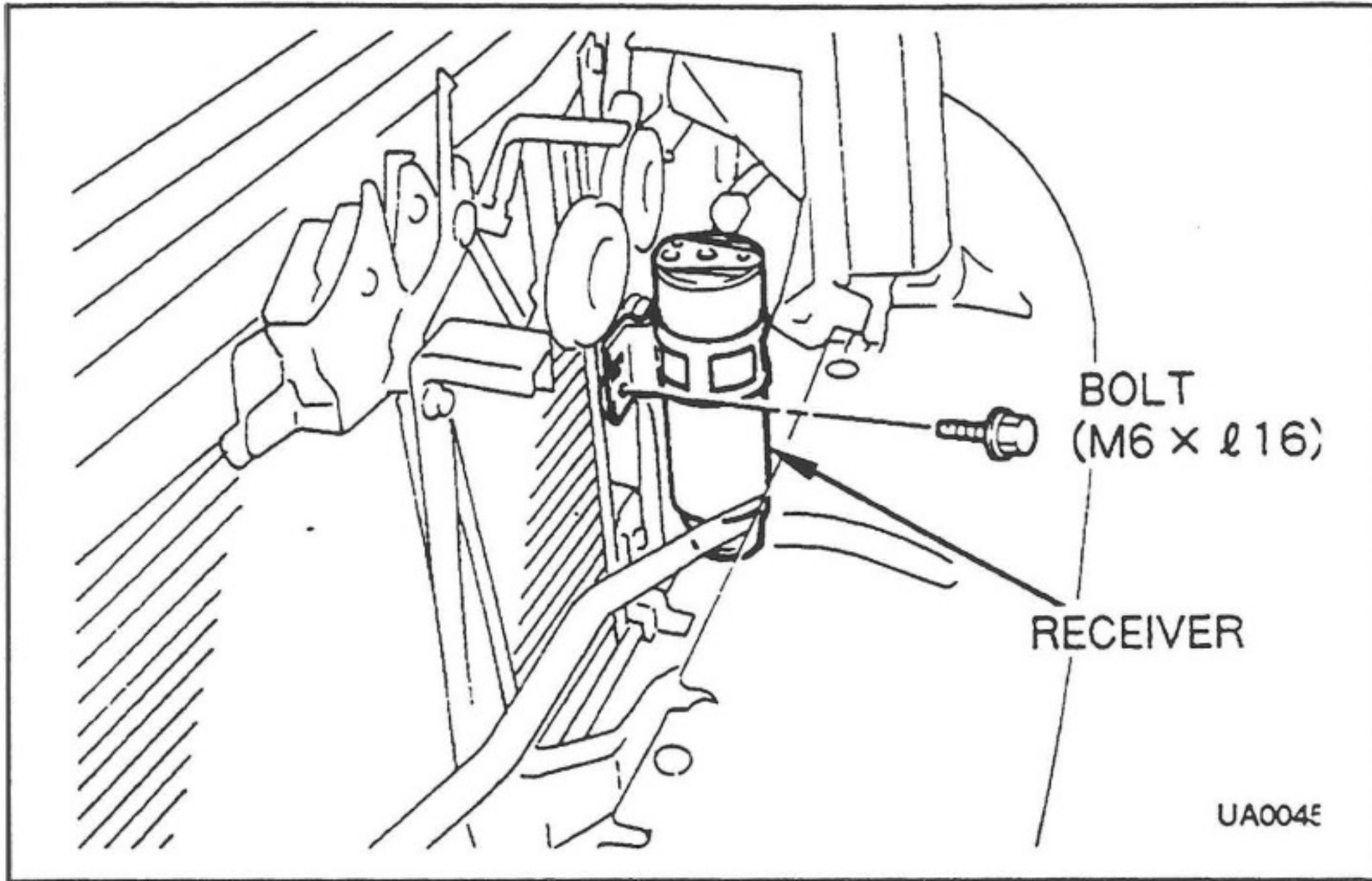

- (b) Install the receiver holder to the condenser bracket using a bolt.

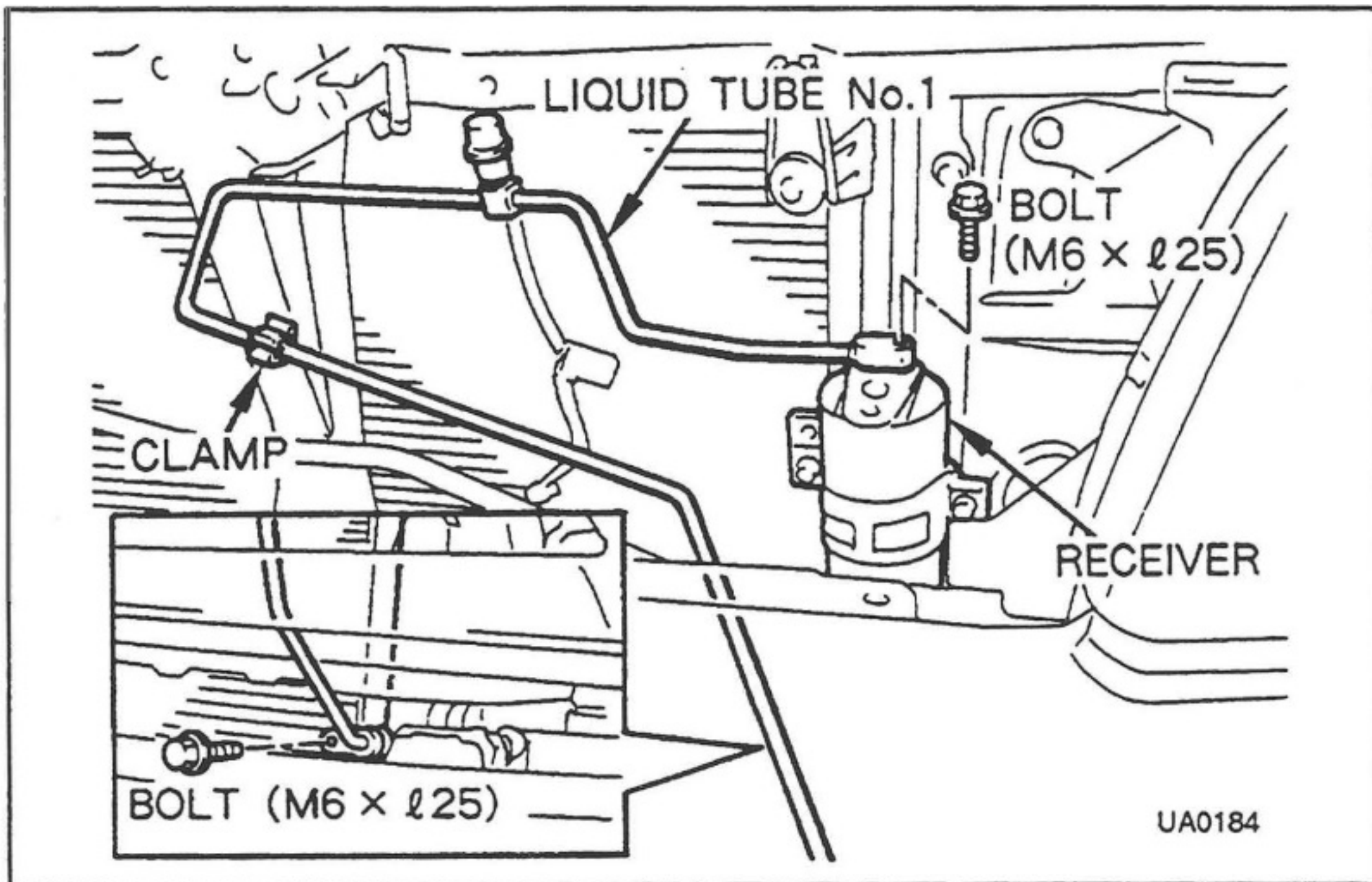

**(6) LIQUID TUBE**

- (a) Connect the liquid tube No.1 from the receiver to the condenser using two bolts,

|                                 |
|---------------------------------|
| Tightening Torque               |
| 5.4 N•m (55 kgf•cm, 4.0 ft•lbf) |

- (b) Fasten the liquid tube No.1 to the clamp.

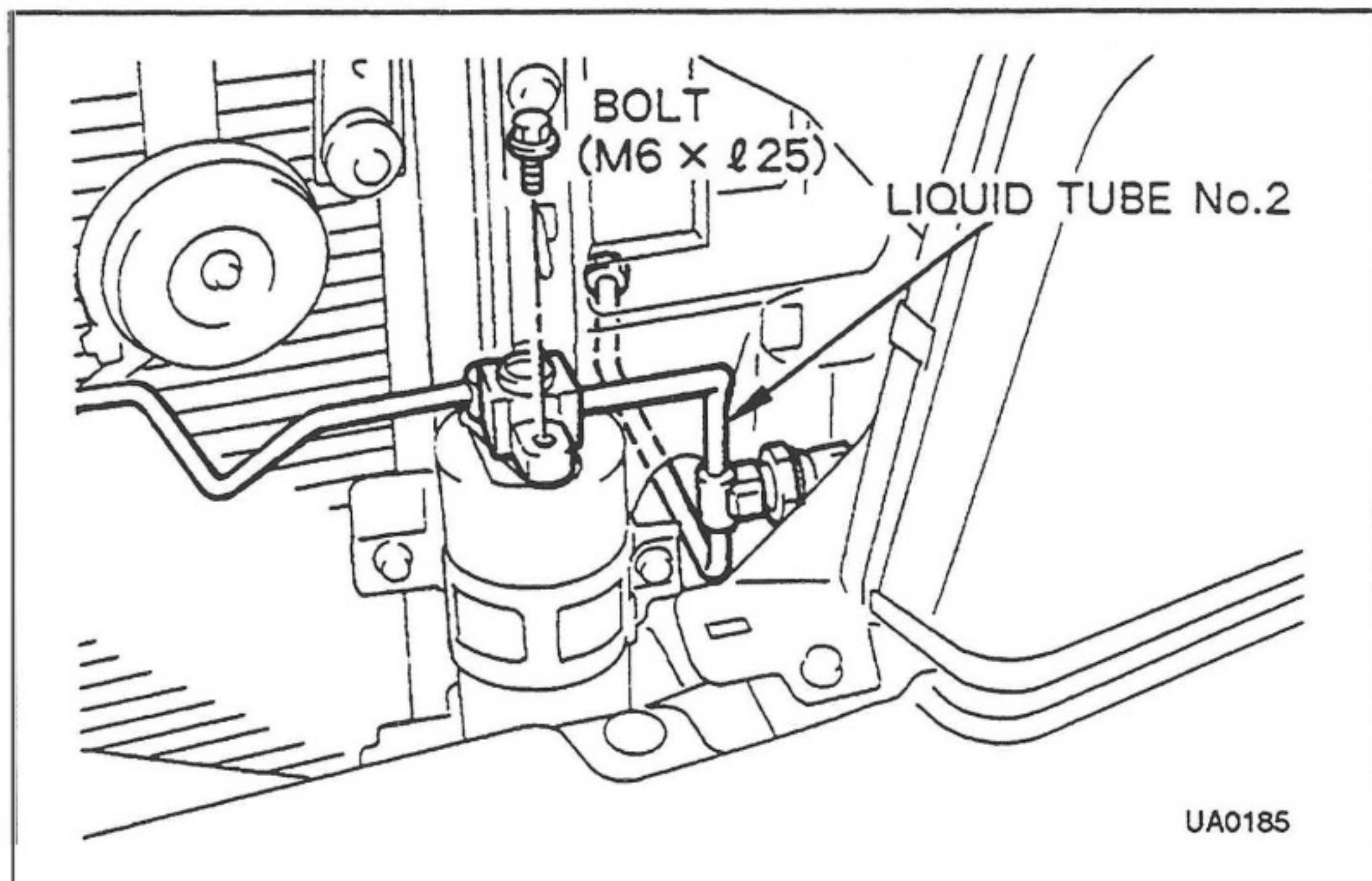

- (c) Connect the liquid tube No.2 to the receiver using the bolt.

|                                 |
|---------------------------------|
| Tightening Torque               |
| 5.4 N•m (55 kgf•cm, 4.0 ft•lbf) |

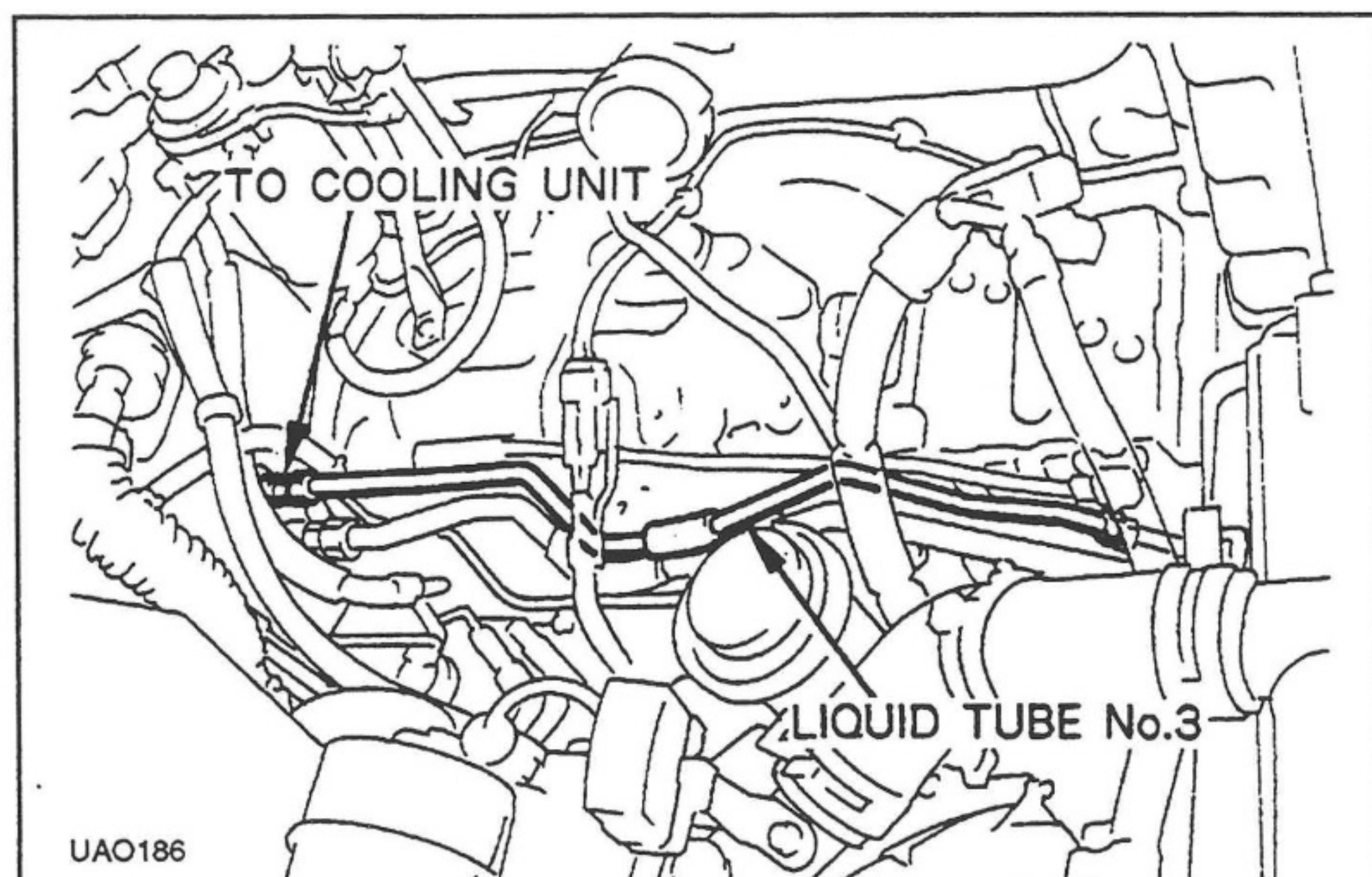

- (d) Route and Connect the liquid tube No.3 as shown.

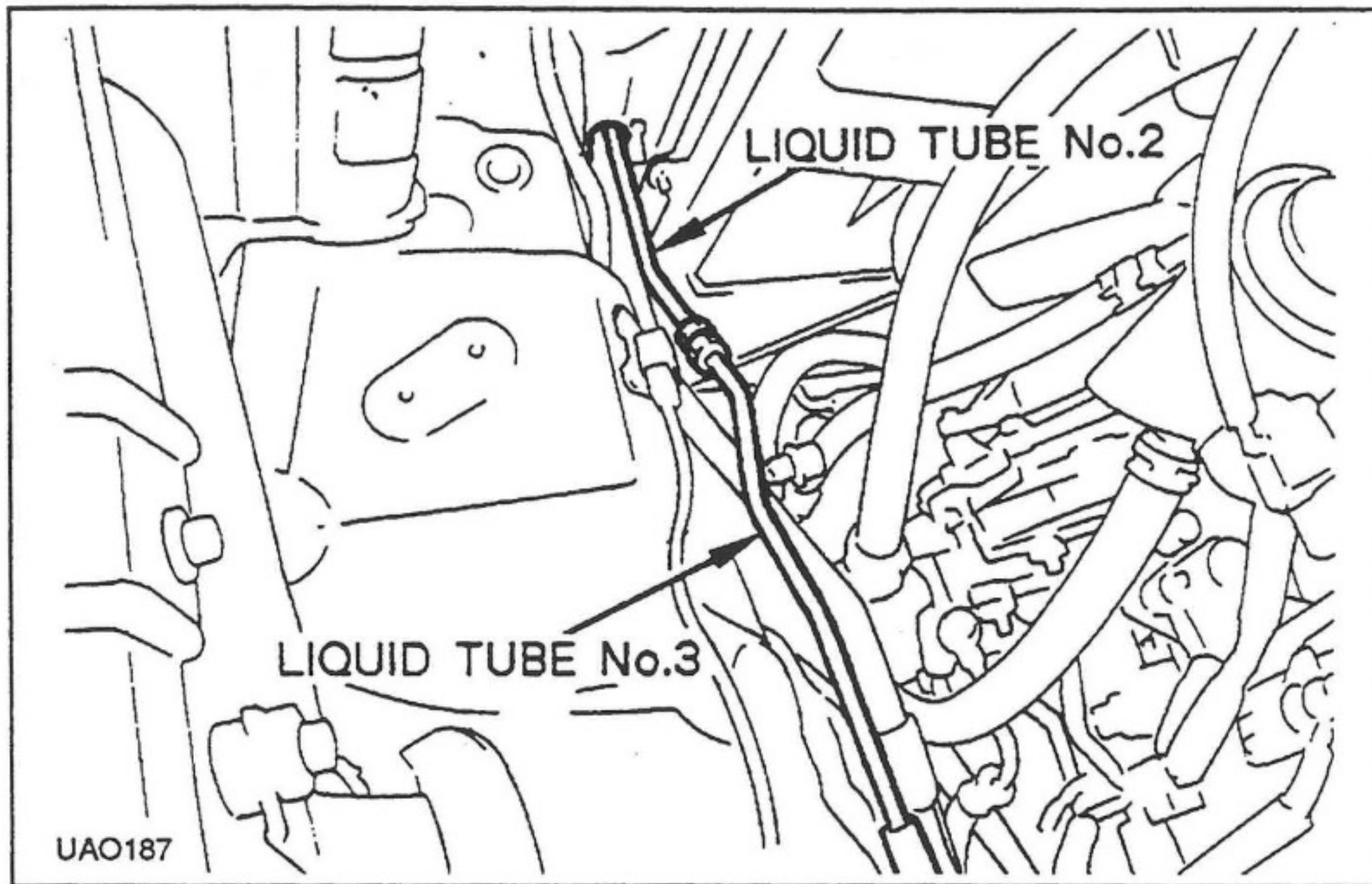

(e) Connect the liquid tube No.2 and No.3.

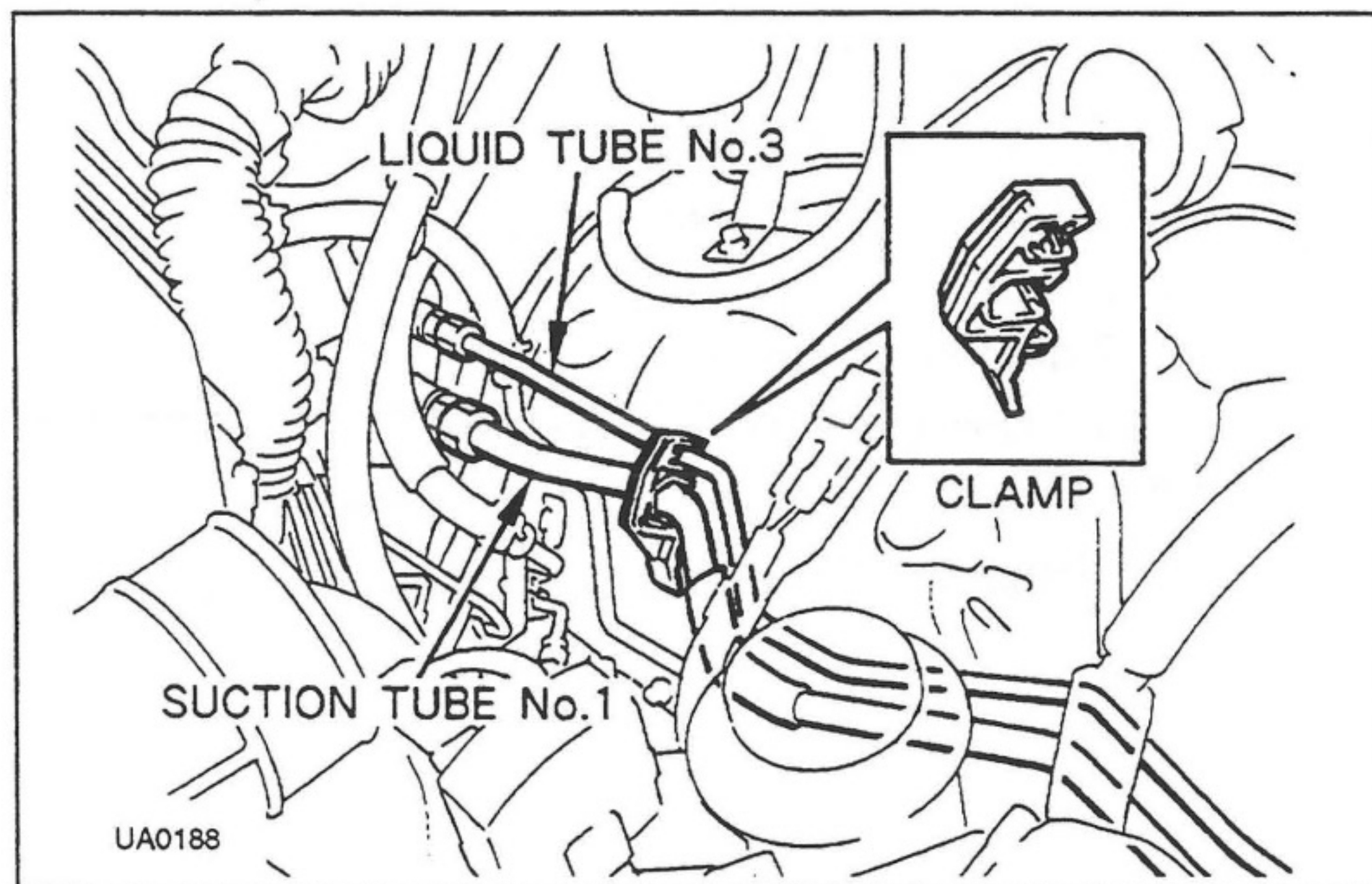

(f) Fasten the suction tube No.1 and liquid tube No.3 to the body using the clamp.

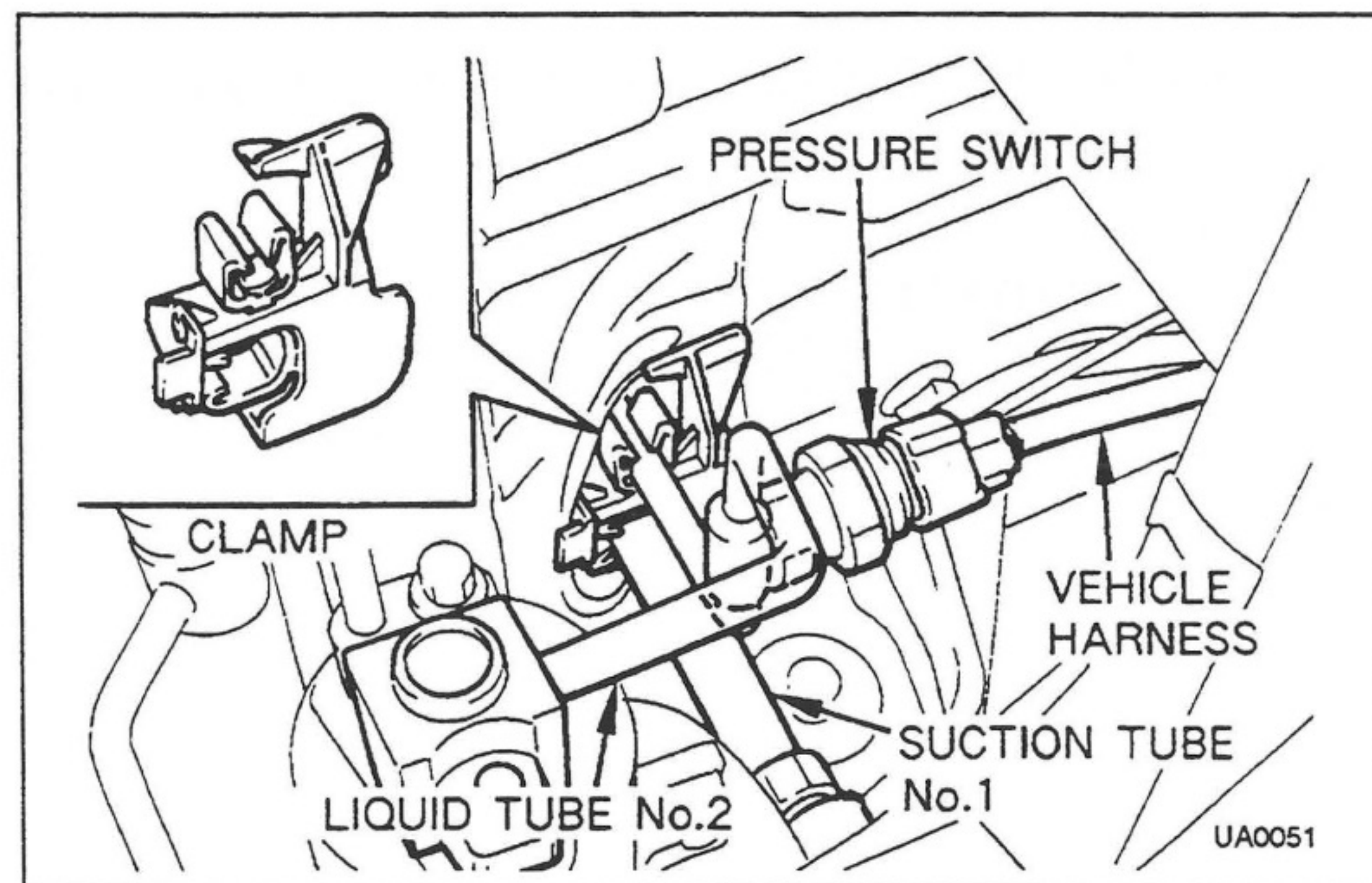

(g) Fasten the liquid tube No.2 and suction tube No.1 to the radiator support panel hole using the clamp.

(h) Connect the vehicle harness to the pressure switch.

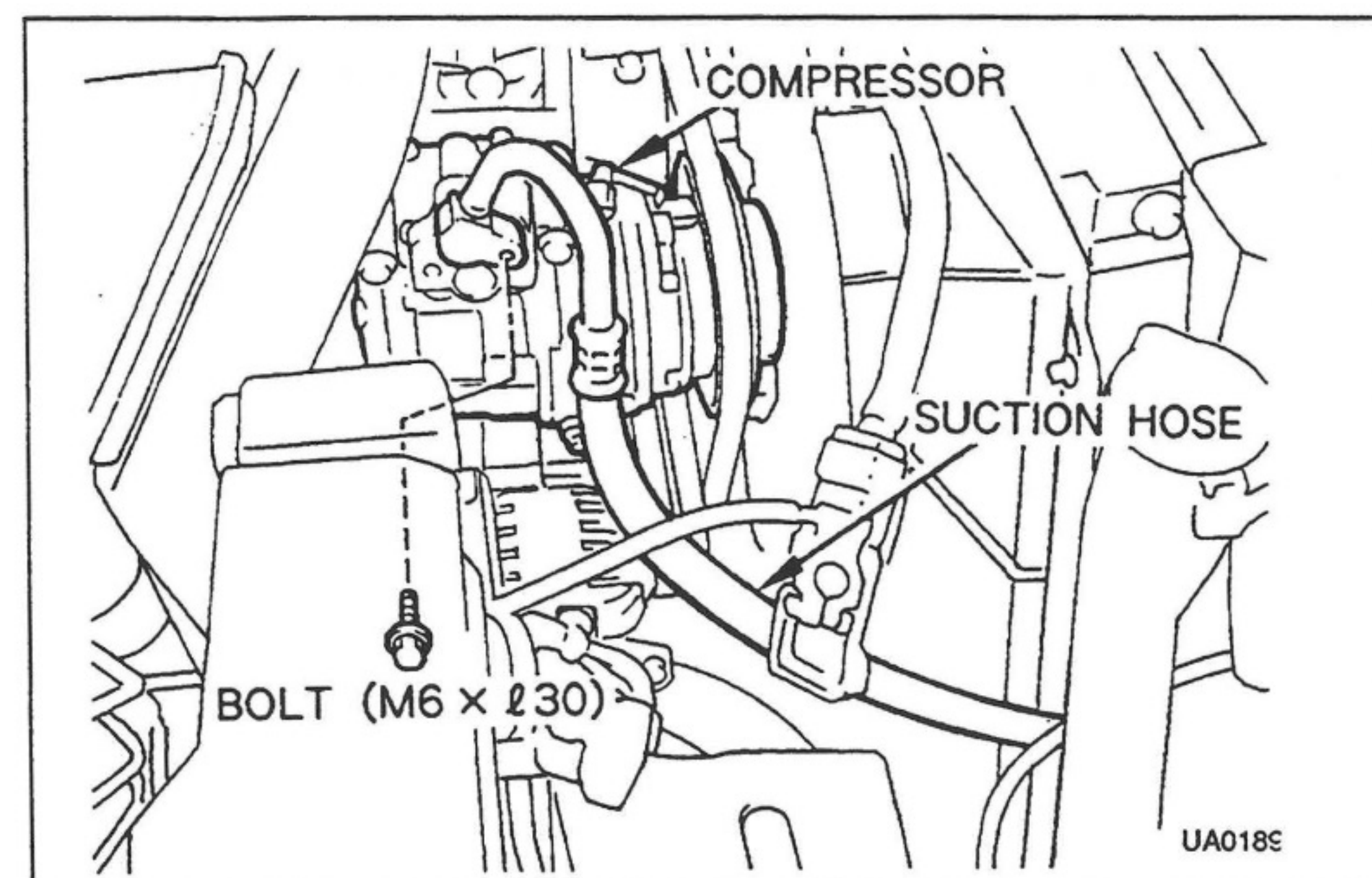

**(7) SUCTION HOSE**

(a) Connect the suction hose from the compressor to the suction tube No.2.

|                                     |
|-------------------------------------|
| Tightening Torque : Compressor side |
|-------------------------------------|

|                                  |
|----------------------------------|
| 9.8 N•m (100 kgf•cm, 7.2 ft•lbf) |
|----------------------------------|

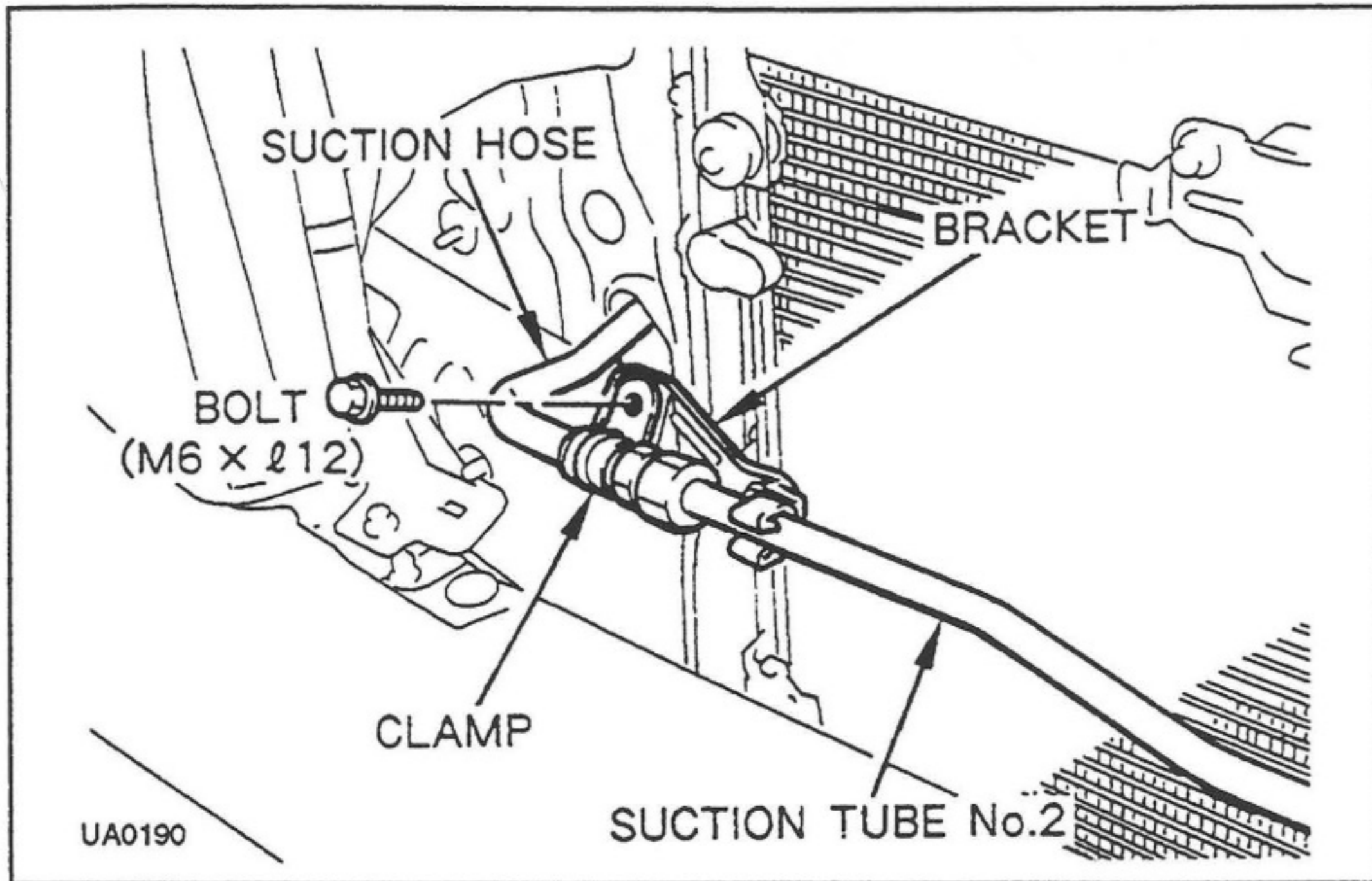

- (b) Connect the suction hose to the suction tube No.2.
- (c) Fasten the suction hose to the bracket using the clamp and a bolt.

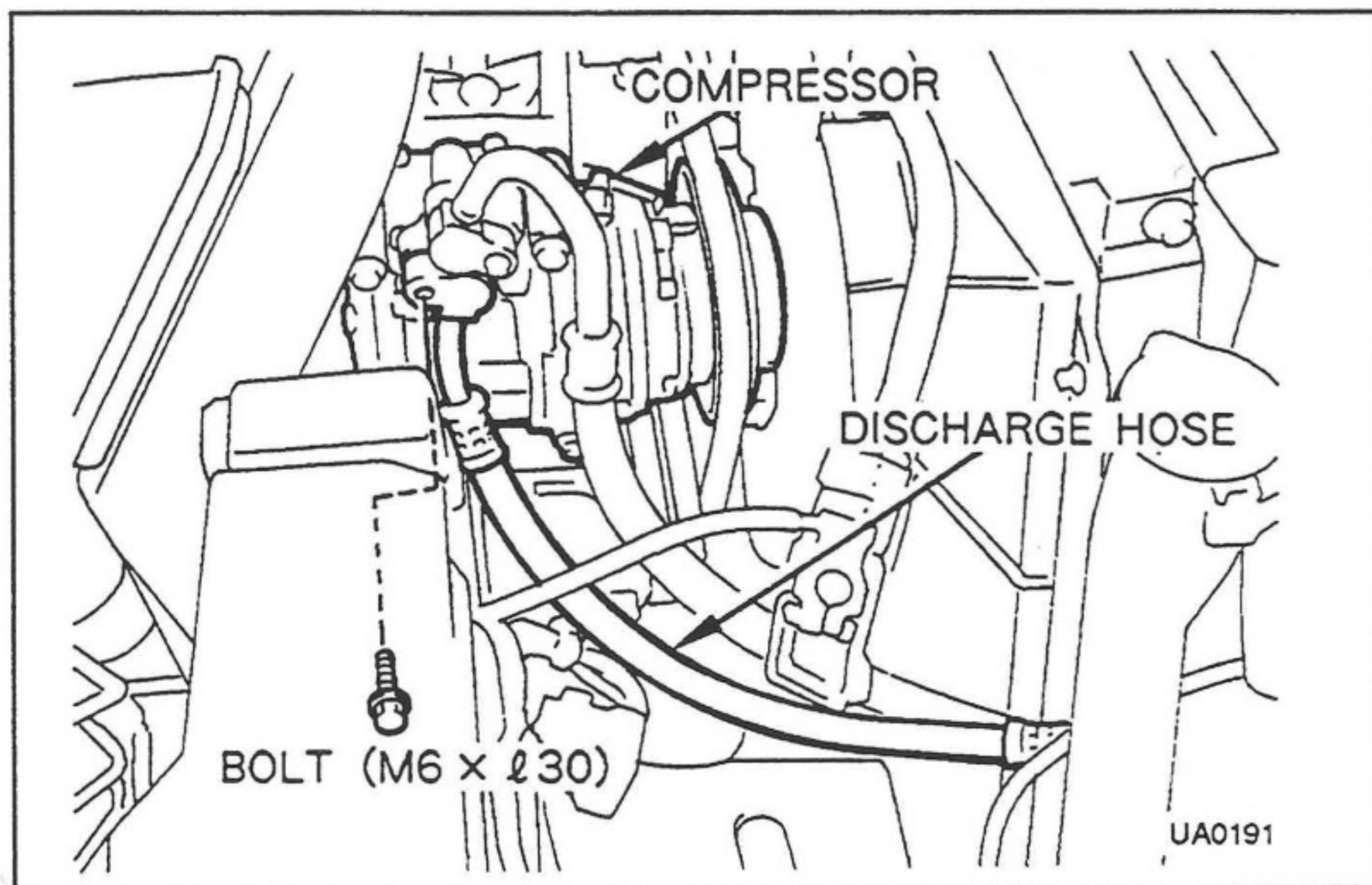

**(8) DISCHARGE HOSE**

- (a) Connect the discharge hose from the compressor to the condenser.

|                                     |
|-------------------------------------|
| Tightening Torque : Compressor side |
| 9.8 N•m (100 kgf•cm, 7.2 ft•lbf)    |

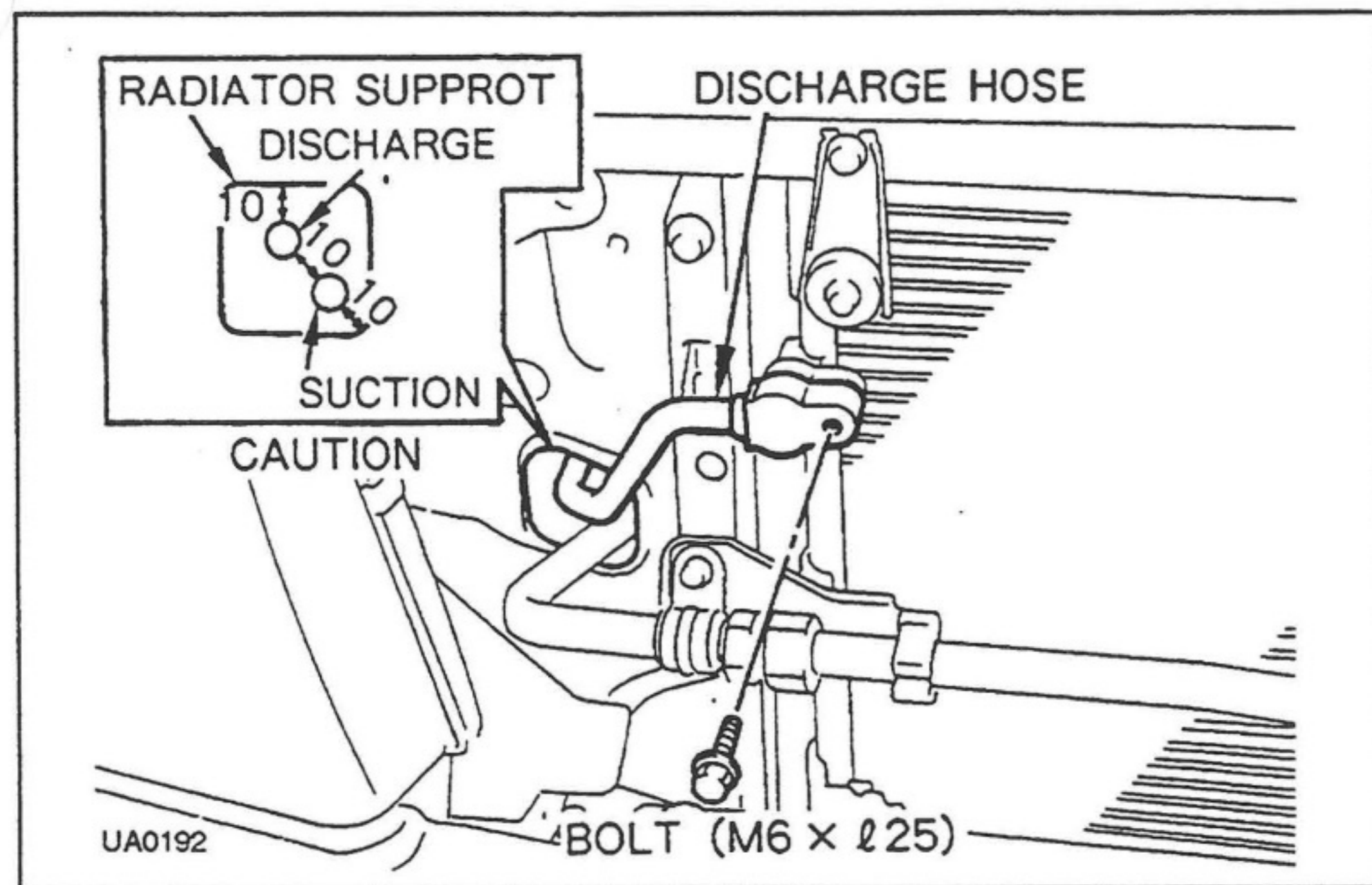

- (b) Connect the discharge hose to the condenser.

|                                    |
|------------------------------------|
| Tightening Torque : Condenser side |
| 5.4 N•m (55 kgf•cm, 4.0 ft•lbf)    |

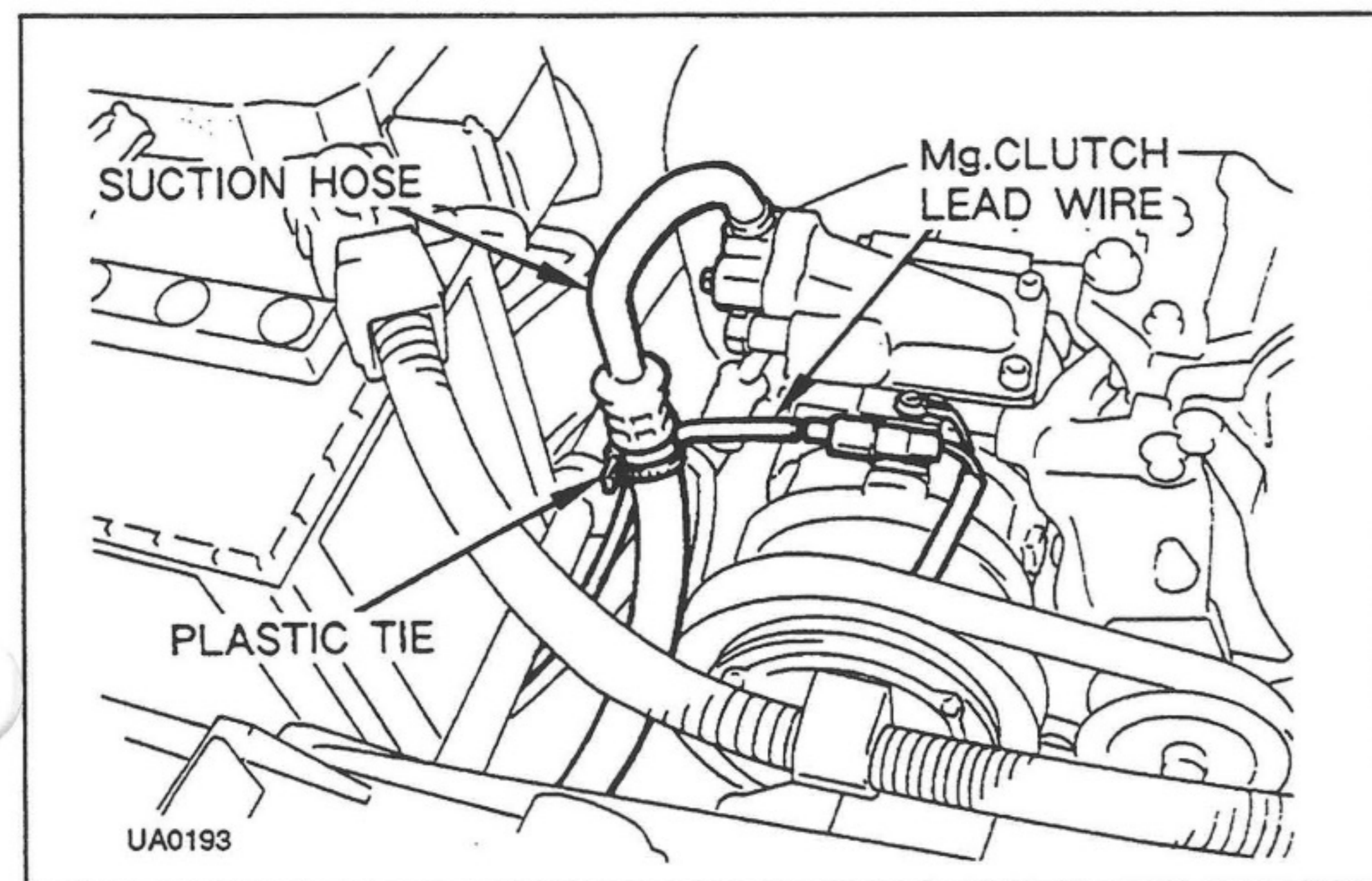

- (c) Secure the Mg/clutch lead wire to the suction hose using the plastic tie.

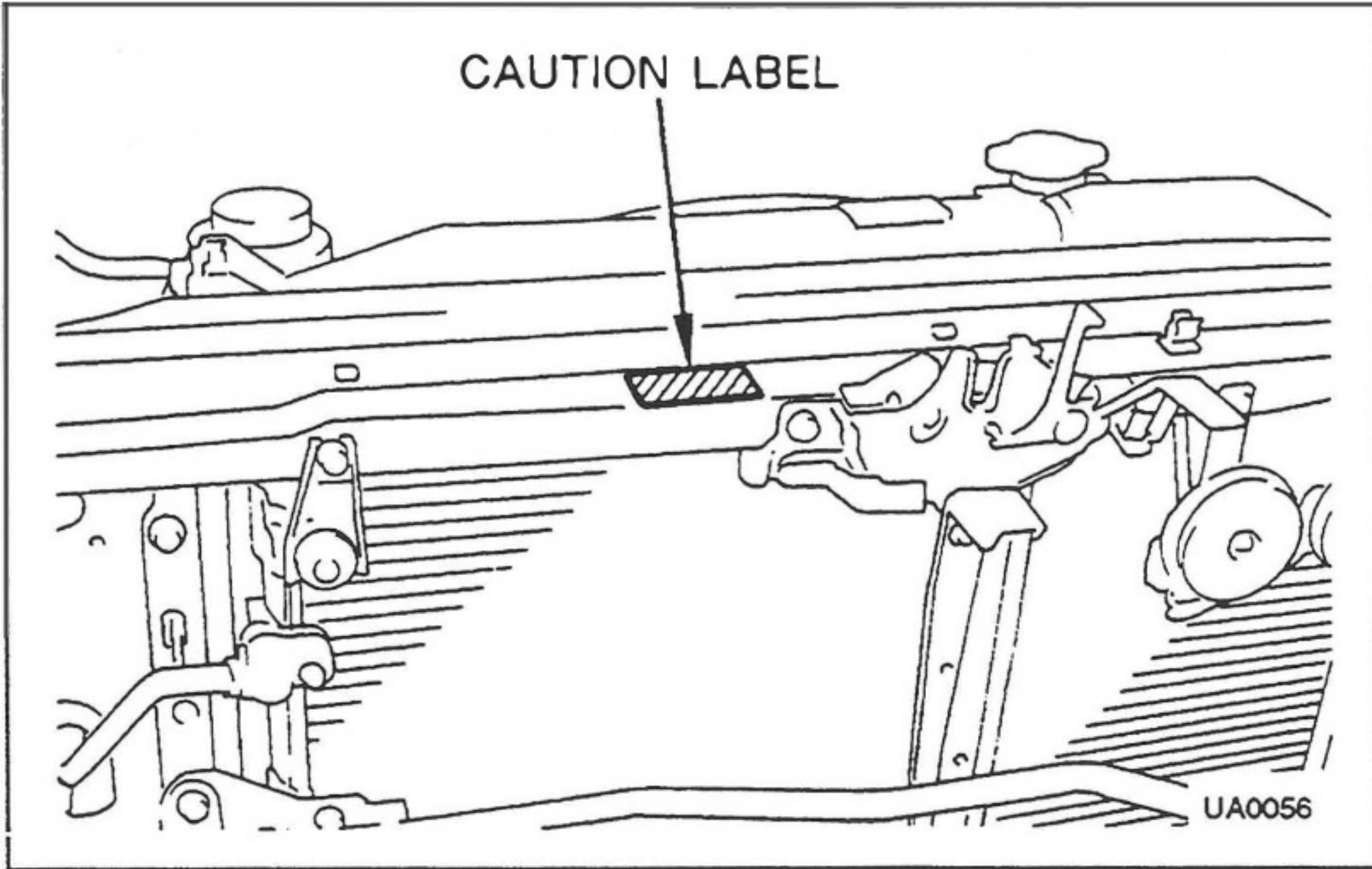

**(9) CAUTION LABEL**

- (a) Attach the caution label onto the radiator upper baffle.

**REINSTALLATION**

Reinstall the all removed parts.

### 3. AFTER INSTALLATION

#### 3-1 CHARGING REFRIGERANT (HFC-134a)

(1) Automatic charging machine

Before evacuating air or charging refrigerant using the automatic charging machine, read the relevant manuals thoroughly.

(2) Charging cylinder

When charging refrigerant using a charging cylinder, evacuate air then charge refrigerant as described below.

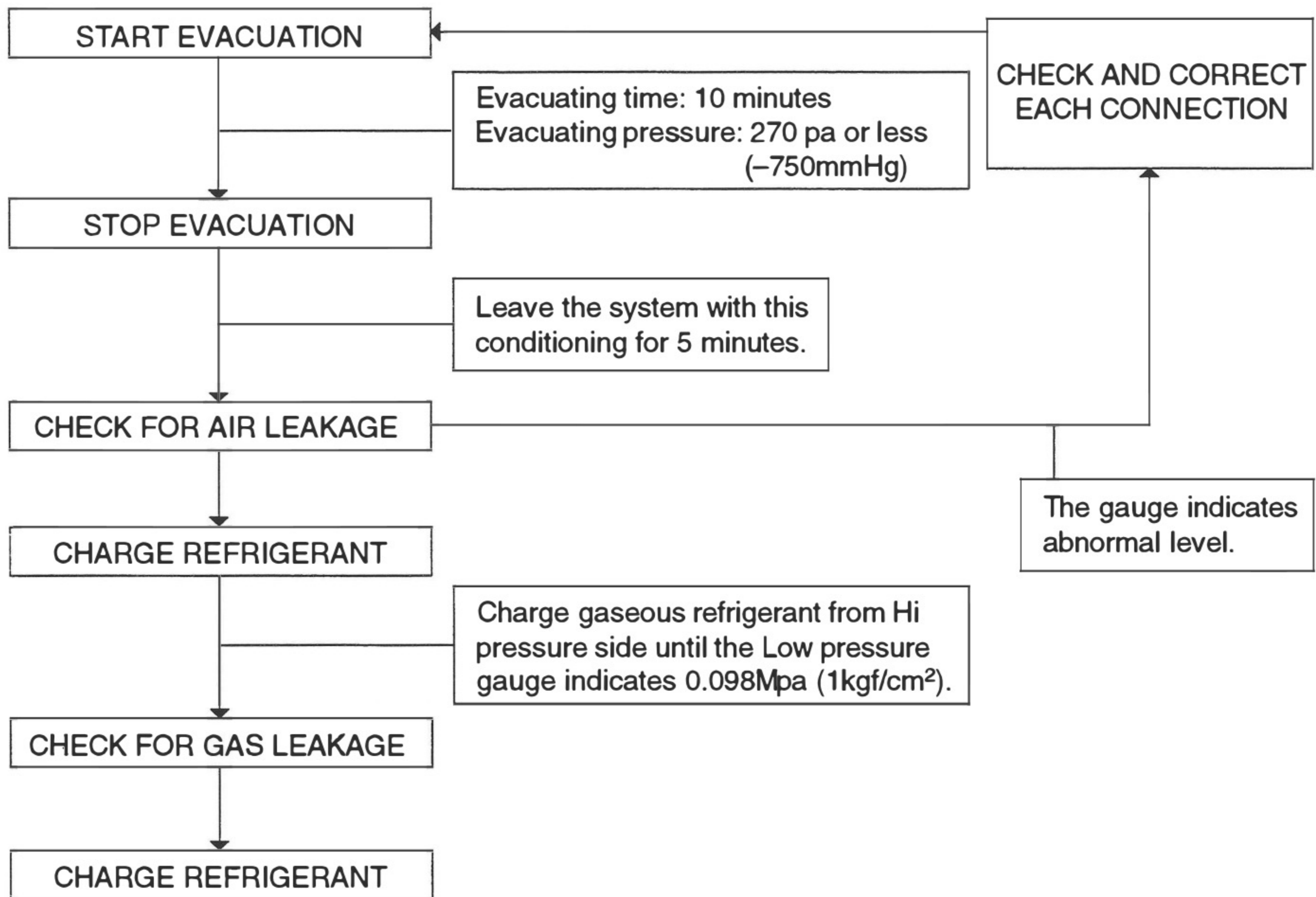

For additional information on charging refrigerant using the charging cylinder, refer to “General Information” (pages 11-13) of this manual.

|                                |                              |
|--------------------------------|------------------------------|
| STANDARD AMOUNT OF REFRIGERANT | 750 ± 50 g (1.65 ± 0.11 lbs) |
|--------------------------------|------------------------------|

**!CAUTION**

Ensure to fill the refrigerant to the specified amount.

## 3-2 FINAL LEAKAGE CHECK

This description is provided here as a reference for the checking procedure. When the air conditioner is installed it is important to fill the specified amount of refrigerant. When checking the refrigerant amount during repairs, for example, consult the vehicle repair manual.

### S Sub-cool condenser systems

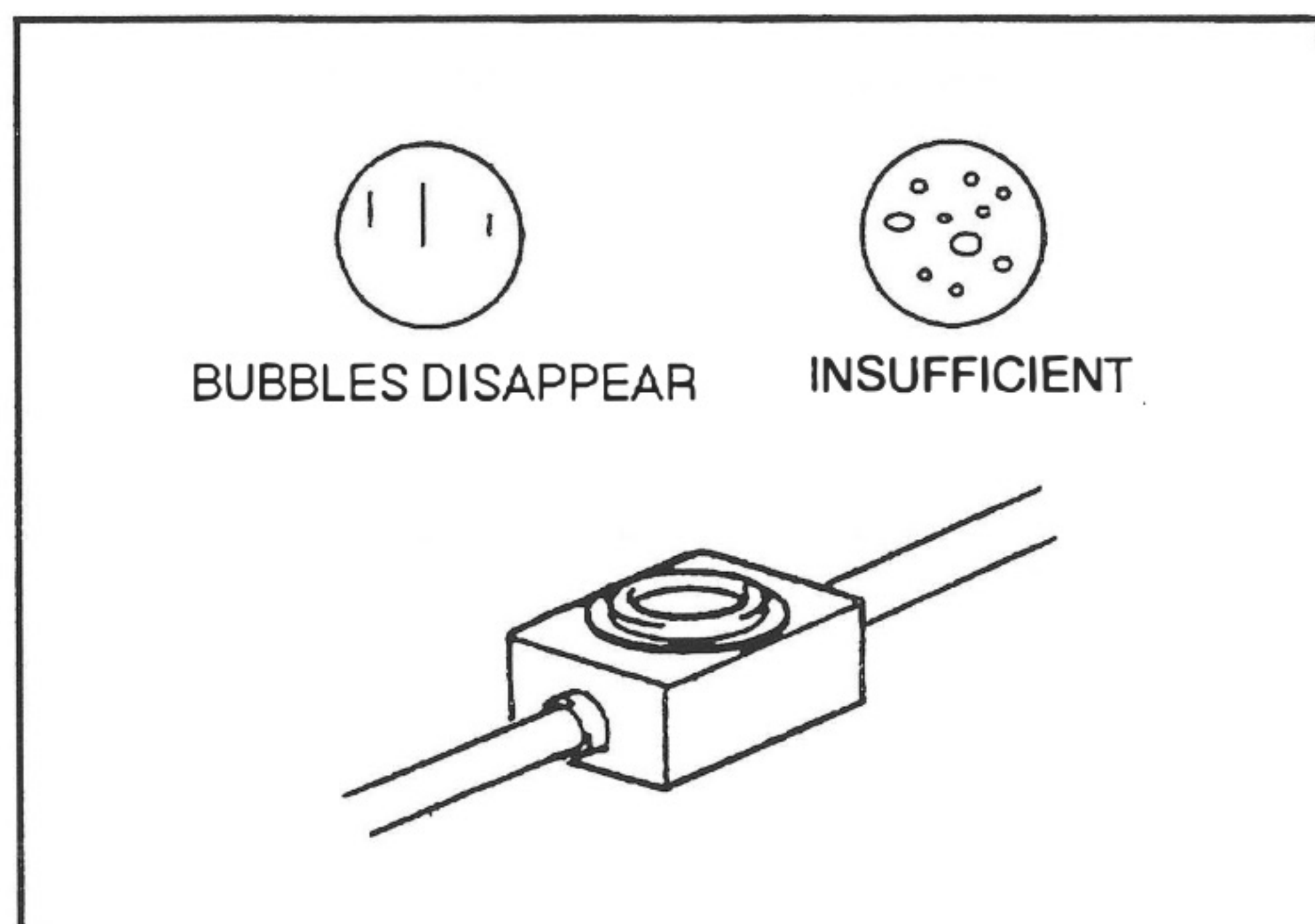

- (1) Fill the refrigerant to the specified amount even when the bubbles have disappeared.

#### **!CAUTION**

*In the sub-cool condenser type system bubbles disappear before the system is fully charged.*

### S Other systems

- (1) Check whether refrigerant amount through the sight glass.

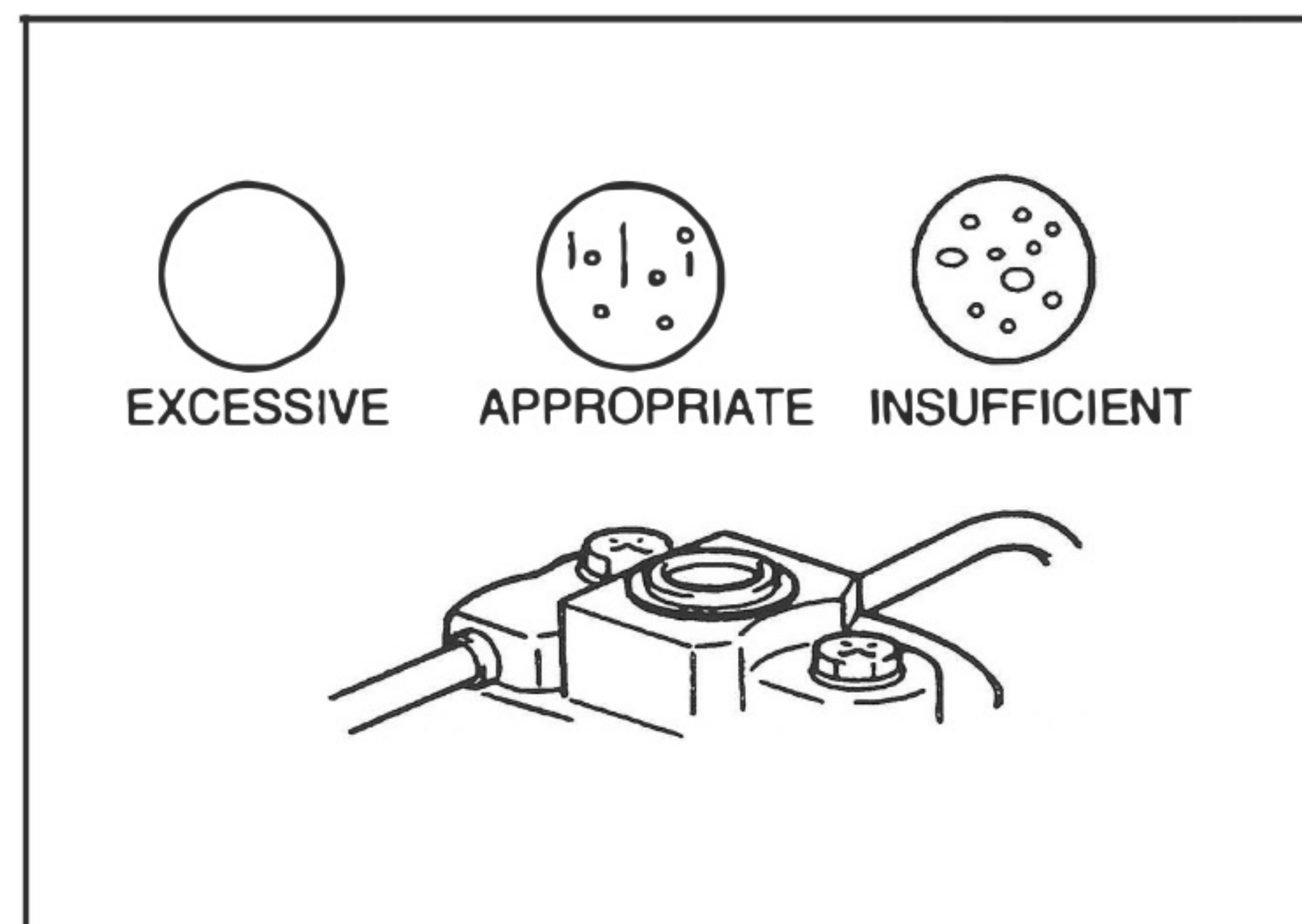

- (a) Set the following conditions  
 Engine speed...Idling  
 In case of dual type A/C...Switch both front and rear ON.
- (b) Visually check a sight glass under the following conditions.
- Appropriate...Almost no bubbles  
 (Idling speed : After gradually increasing speed, bubbles disappear at 1500 rpm.)
- Excessive...No bubbles  
 (Pressures on both the high and low side are high.)
- Insufficient...Continuous bubble occurrence

#### **NOTE**

1. Pressure on the high pressure side when charging refrigerant should be 19 kg/cm<sup>2</sup> (1.87 Mpa) or less. When outside air temperature is high (40 °C or more) and if the pressure becomes more than 19 kg/cm (1.87 Mpa), perform the check in a cool place with all the doors open and with the blower speed set to LO.
2. When an electric fan starts with an appropriate refrigerant level, bubbles might appear temporarily. (For about 5 seconds)

- (2) In case of a 'low charge' above, there may be a leak. Then, Check joint areas of each part with a leak tester, and repair the leak.

### 3-3 RE-ADJUSTMENT OF COMPRESSOR BELT

To correct belt deflection caused by initial elongation, the air conditioning must be operated for at least 5 minutes before the final adjustment of the belt.

|                                  | Belt deflection<br>[at 98N(10kgf, 22lbf)force] | Belt tension<br>[N (kgf)]     |
|----------------------------------|--|-------------------------------|
| Vehicle equipped with 1KZ-TE E/G | 15 - 21 mm                                     | 30 + 10 kgf<br>( 66 + 22 lbf) |

#### !CAUTION

1. Excessive tension of belt may have an adverse effect on bearings, while excessive slackness can cause the belt to slip, make abnormal noise or shorten the belt life.
2. The belt deflection must be measured between the specified pulleys as indicated in this manual.
3. The belt tension must be measured between the specified pulleys as indicated in this manual.
4. The belt tension must be adjusted to the center of the specified belt tension range.

### 3-4 RESTORE THE VEHICLE

Reinstall all the parts of vehicle that have been temporarily removed.

#### !CAUTION

1. In particular, improper installation of instrument panel's parts, improper tightening of tapping screws or loose connectors may cause abnormal noise. Therefore make sure that they are installed or fastened properly to avoid abnormal noise that can occur after the air conditioning installation is complete.
  - Tightening torque for tapping screw .....  $1.5 \begin{smallmatrix} +0.5 \\ -0 \end{smallmatrix}$  N·m ( $15 \begin{smallmatrix} +5 \\ -0 \end{smallmatrix}$  kgf·cm)
  - Tightening torque for cross recessed head bolt .....  $3.4 \pm 1.4$  N·m ( $35 \pm 15$  kgf·cm)
2. If the hole for a tapping screws is too large, use a tapping screw one-size larger.
3. Reinstall each part with particular care so that its clips, guides bosses fit in the specified positions.
4. When installing the instrument panel, make sure that wire harness is not pulled, pushed excessively or trapped.

### 3-5 FINAL INSPECTION (SAFETY CHECK)

After installing the air conditioning, check for safety and operation of each section shown below.

(1) Inspection after completion of installation

| No. | ITEM         | DESCRIPTION   | CHECK |
|-----|--------------|---|-------|
| 1   | A/C Parts    | Install and fasten properly.  |       |
| 2   | Wiring       | Do not pinch harness. Make sure connectors are secure.                        |       |
| 3   | Vacuum Hoses | Do not bend excessively, pinch or constrict.                                  |       |
| 4   | Safety Gaps  | Maintain specified or in excess of that specified in the installation manual. |       |
| 5   | Compressor   | There should be no abnormal noise during operation.                           |       |

(2) Check for operation of the air conditioning unit

| No. | ITEM                          | DESCRIPTION     | CHECK |
|-----|-------------------------------|-----------------|-------|
| 1   | Activation of Magnetic Clutch | ON/OFF          |       |
| 2   | Blower Motor Speed Change     | Lo to Hi        |       |
| 3   | Air Outlet Change             | Lever Operation |       |
| 4   | FRS/REC. Change               | Lever Operation |       |
| 5   | Temperature Adjustment        | COOL to HOT     |       |
| 6   | Condenser fan                 | Operation       |       |

(3) Check for operation of each electrical component in the vehicle (To be carried out before and after installation of the air conditioning unit)

| ITEM         | CHECK  |       | ITEM              | CHECK  |       | CHECK ITEM     | CHECK  |       |
|--------------|--------|-------|-------------------|--------|-------|----------------|--------|-------|
|              | Before | After |                   | Before | After |                | Before | After |
| Turn Signals |        |       | Horn              |        |       | Clock          |        |       |
| Flashers     |        |       | Washer            |        |       | Radio          |        |       |
| Head lights  |        |       | Wipers            |        |       | Blower Motor   |        |       |
| Stop lights  |        |       | Inside lights     |        |       | Back up lights |        |       |
| Tail lights  |        |       | Cigarette lighter |        |       |                |        |       |

THE AIR CONDITIONER IS NOW READY FOR USE. BE SURE TO EXPLAIN OPERATION TO THE OWNER.

# 4. WIRING DIAGRAM

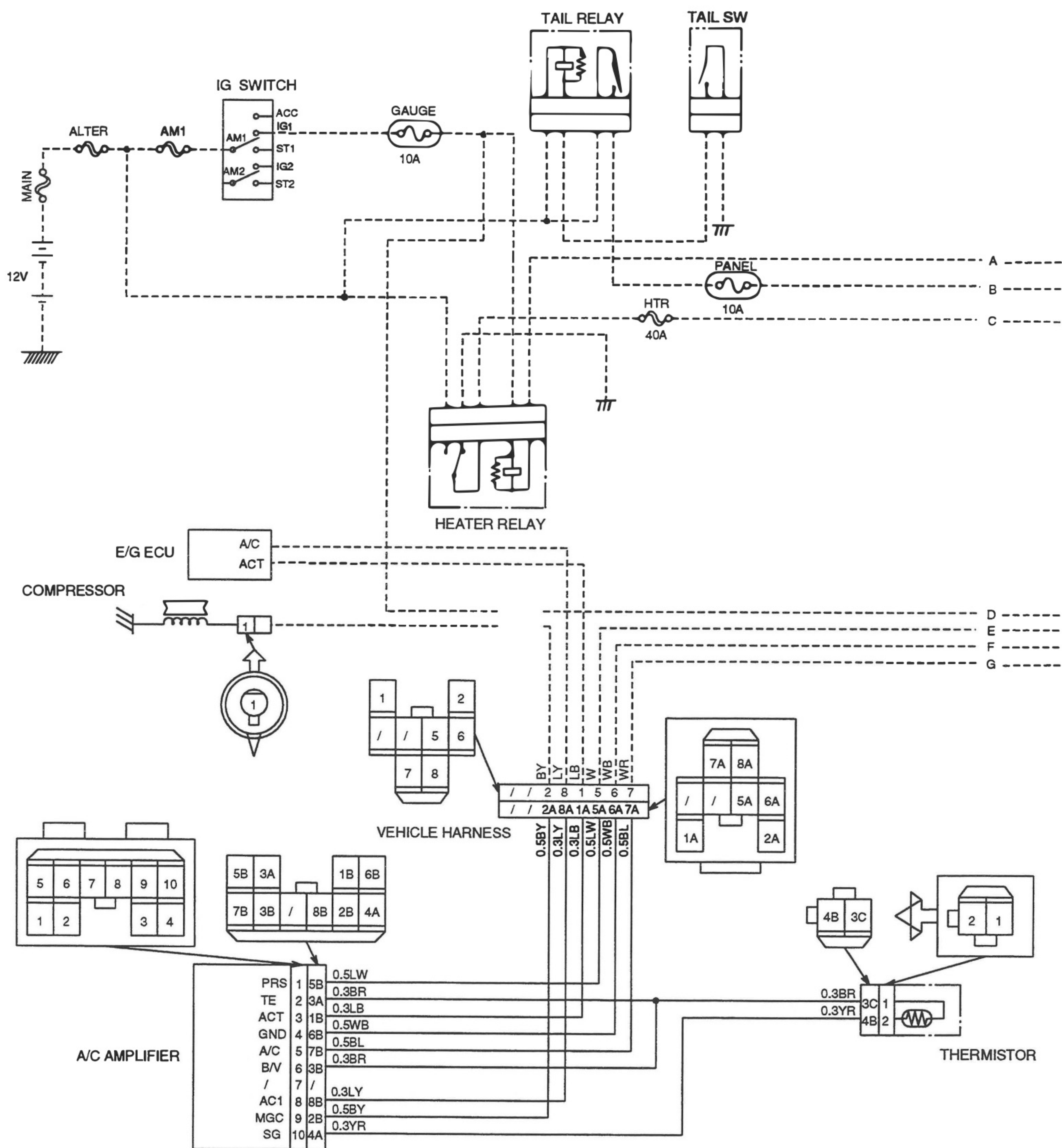

246107-453 (L)

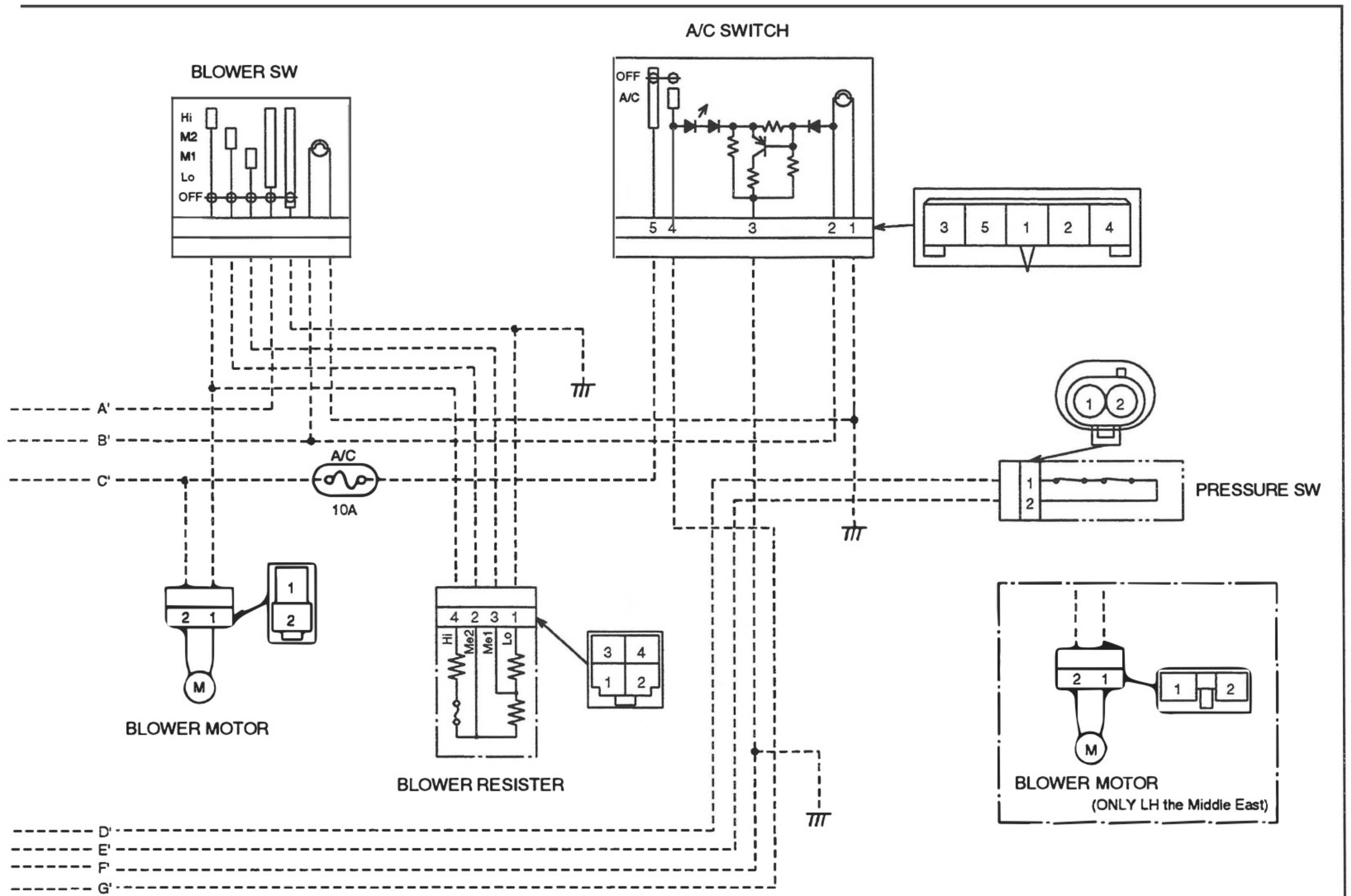

- Wiring Classification
- (1) - - - - - VEHICLE HARNESS
  - (2) ———— A/C HARNESS
  - (3) Color

|       |       |      |     |       |        |       |      |      |        |
|-------|-------|------|-----|-------|--------|-------|------|------|--------|
| B     | G     | L    | R   | W     | Y      | Br    | Gr   | P    | O      |
| BLACK | GREEN | BLUE | RED | WHITE | YELLOW | BROWN | GRAY | PINK | ORANGE |

246107-453 ■ (R)