



# **TOYOTA LAND CRUISER**

VZJ95R

## **AIR CONDITIONING**

**NIPPONDENSO (AUSTRALIA) PTY. LTD.**

MAC-1079

**INSTALLATION MANUAL**

# INTRODUCTION

## IMPORTANT NOTICE

This manual has been designed for technicians who are qualified and educated in the proper procedures of vehicle safety, handling and maintenance; experienced in installation of car air conditioning or who are able to carry out installation procedures when given instructions by an experienced technician in a supervisory capacity; and are certified to handling refrigerant.

1. Take special care to ensure that clearance between air conditioning components and other components such as brake parts, fuel system and electric wires as specified in this manual.
2. If a problem is found with the air conditioning system due to installation, refer back to the manual to correct the problem(s).
3. Vehicle and air conditioning kit components as well as installation procedures are subject to change without prior notice. Refer to the latest installation manual and service information. Any changes affecting the above items will be given in the form of a "Installation instructions for air conditioning (Supplement)" (issued by NIPPONDENSO) or a service bulletin (issued by the manufacturer).

## DEFINITION OF TERMS

! **WARNING** : Describes precautions that should be observed in order to prevent injury or death to the user during installation.

! **CAUTION** : Describes precautions that should be observed in order to prevent damage to the vehicle or its components, which may occur during installation if insufficient care is taken.

**NOTE** : Provides additional information that facilitates installation work.

**FRONT, REAR** : Shows the direction when viewed from the driver's seat.

**LEFT, RIGHT**

© 1996 NIPPONDENSO CO., LTD.

All Rights Reserved. This book may not be reproduced or copied, in whole or in part, without the written permission of the publisher.

# FOREWORD

This manual has been published to explain how to install the air conditioning for TOYOTA LANDCRUISER (5VZ-FE E/G). When installing the air conditioning, installation should be performed as described in this manual.

[APPLICATION VEHICLE]

VEHICLE NAME	MODEL CODE	PRODUCTION PERIOD	ENGINE TYPE	STEERING POSITION	DESTINATION
LANDCRUISER	VZJ95R	1996.4-	5VZ-FE	RHD	AUSTRALIA

## TABLE OF CONTENTS

1. GENERAL INFORMATION .....	1
1-1 PRECAUTIONS DURING INSTALLATION .....	1
1-2 INSTALLATION PREPARATION .....	1
1-3 TIGHTENING TORQUE .....	2
1-4 PRECAUTIONS FOR SAFETY INSTALLATION .....	4
2. INSTALLATION .....	9
2-1 INSTALLATION INSIDE PASSENGER COMPARTMENT .....	9
2-2 INSTALLATION INSIDE ENGINE COMPARTMENT .....	14
3. AFTER INSTALLATION .....	26
3-1 CHARGING REFRIGERANT (HFC-134a) .....	26
3-2 RE-ADJUSTMENT OF COMPRESSOR BELT .....	26
3-3 RESTORING THE VEHICLE .....	27
3-4 FINAL INSPECTION (SAFETY CHECK) .....	28
4. A/C AMPLIFIER .....	29
5. WIRING DIAGRAM .....	30

# 1. GENERAL INFORMATION

## 1-1 PRECAUTIONS DURING INSTALLATION

### ! WARNING

1. The contents given in “**WARNING**” and “**CAUTION**” in this manual must be adhered to during installation. If they are ignored, not only the functions of the air conditioning are hindered, but also personal injury or damage to the vehicle may result. Always carry out the installation in accordance with the “**WARNING**” and “**CAUTION**” as noted.
2. Safety Precautions
  - (a) If installation is carried out by more than two persons, always pay attention to co-worker’s safety.
  - (b) When the engine is running, make sure that sufficient ventilation is provided.
  - (c) Take special care when working with heated, rotating, sliding, or moving parts, to prevent bodily injury.
  - (d) When raising the vehicle, refer to the appropriate manufacturer’s service manual.
  - (e) For heavy duty trucks, when tilting the cabin forward, refer to the service manual provided by the vehicle’s manufacturer to prevent damage or personal injury. Make sure the cabin is locked down after it has been tilted forward to prevent it from closing.

## 1-2 INSTALLATION PREPARATION

- (1) Prior to installing the air conditioning, check the following for damage or malfunctions.
  - (a) Internal and external trim and bodywork.
  - (b) Engine idle speed.
  - (c) Engine cooling system.
  - (d) All vehicle functions. (Headlights, indicators, horn, etc.)
- (2) Air Conditioning parts preparation
  - (a) Make sure that the correct kit has been selected for the installation.
  - (b) When unpacking the kit, lay out all parts in order of installation and check for missing or damaged parts.
  - (c) When installing the air conditioning, use fender covers, floor covers and seat covers for protection.

### [INSTALLATION TOOLS]

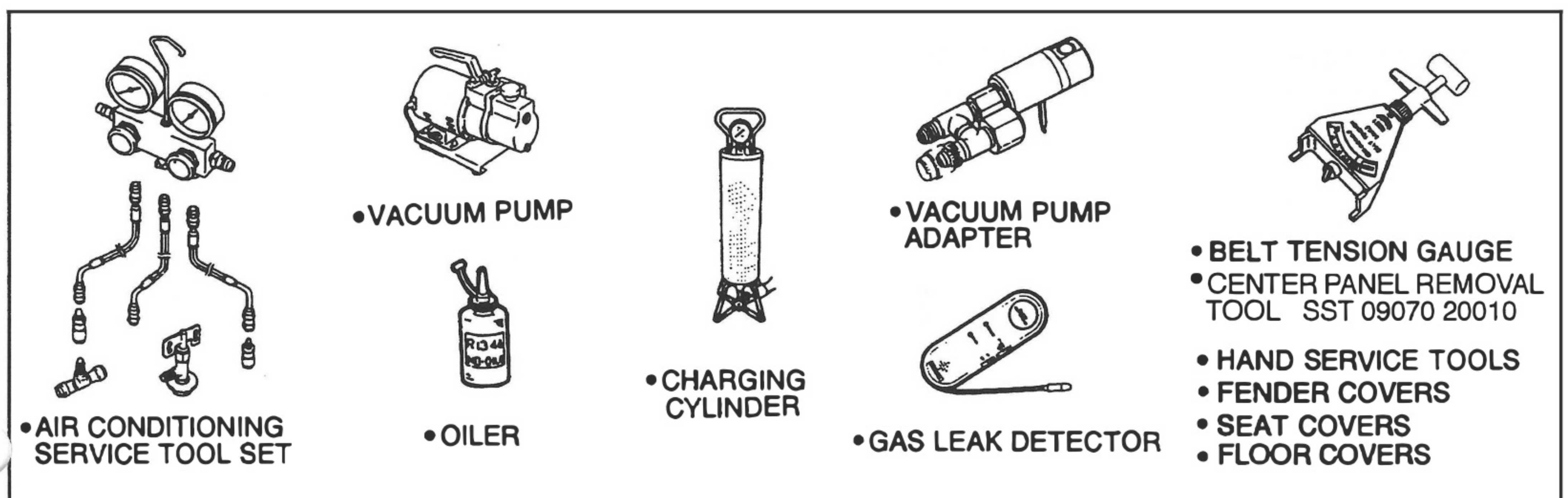

# 1-3 TIGHTENING TORQUE

- (1) Where tightening torque is specified, always tighten there with the specified torque.
- (2) Where tightening torque is not specified, refer to the tightening torque table.
- (3) Bolts marked with ⑧ must be used for engine components, which are likely to be subject to heavy load. Never substitute the bolts marked ⑧ with other bolts.
- (4) Nuts must be fastened with the tightening torque specified for the related bolts.



### [TIGHTENING TORQUE TABLE (GENERAL)]

[Unit : N•m]							
Diam. (mm)	Pitch (mm)	4T	5T	6T	7T	8T	10T
6	1.00	5.4± 1.0	6.4± 1.1	7.8± 1.4	10.8± 1.9	—	—
8	1.25	12.7± 2.5	15.7± 2.9	19.1± 3.4	25.5± 5.9	29.4± 5.9	38.2± 7.4
10	1.25	25.5± 4.9	32.4± 6.3	39.2± 7.8	52.0±10.2	60.8±11.8	78.5±15.6
12	1.25	47.1± 9.3	58.8±11.7	71.6±14.2	95.1±18.6	107.9±21.5	142.2±28.3
14	1.50	74.5±14.7	91.2±18.1	107.9±21.6	147.1±29.4	—	—
16	1.50	112.8±22.5	137.3±27.5	171.6±34.3	225.6±45.1	—	—
[Unit : kgf•cm]							
Diam. (mm)	Pitch (mm)	4T	5T	6T	7T	8T	10T
6	1.00	55± 10	65± 10	80± 15	110± 20	—	—
8	1.25	130± 25	160± 30	195± 35	260± 50	300± 60	390± 75
10	1.25	260± 50	330± 65	400± 80	530± 105	620± 120	800± 160
12	1.25	480± 95	600± 120	730± 145	970± 190	1100± 220	1450± 290
14	1.50	760± 150	930± 185	1100± 220	1500± 300	—	—
16	1.50	1150± 230	1400± 280	1750± 350	2300± 460	—	—
[Unit : ft•lbf]							
Diam. (mm)	Pitch (mm)	4T	5T	6T	7T	8T	10T
6	1.00	4.0± 0.7	4.7± 0.7	5.8± 1.0	7.9± 1.3	—	—
8	1.25	9.4± 1.8	11.5± 2.1	14.1± 2.4	18.7± 3.6	21.7± 4.3	28.1± 5.4
10	1.25	18.8± 3.6	23.8± 4.6	29.0± 5.7	38.2± 7.4	44.8± 8.6	56.7±11.4
12	1.25	37.4± 6.8	43.2± 8.5	52.8±10.4	69.9±13.6	79.6±15.7	104.5±20.7
14	1.50	54.7±10.8	67.0±13.2	79.3±15.8	108.1±21.6	—	—
16	1.50	82.9±16.5	100.9±20.2	126.0±25.2	165.7±33.1	—	—

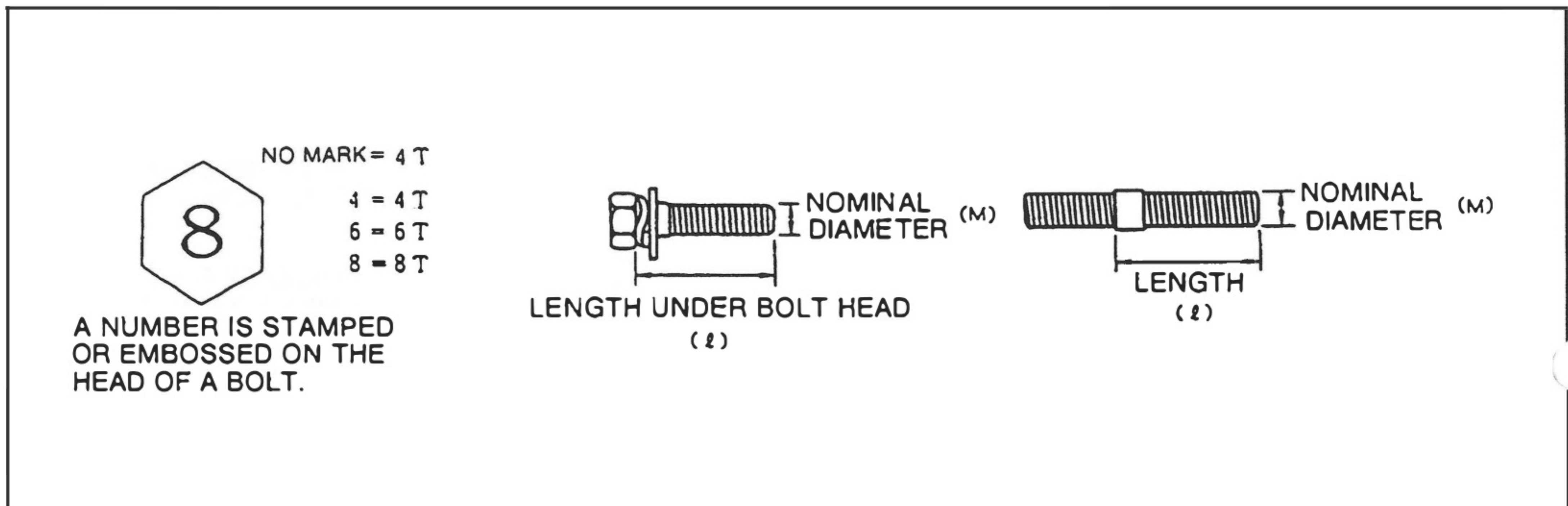
### [IDENTIFICATION OF BOLT STRENGTH (BOLT SIZES)]

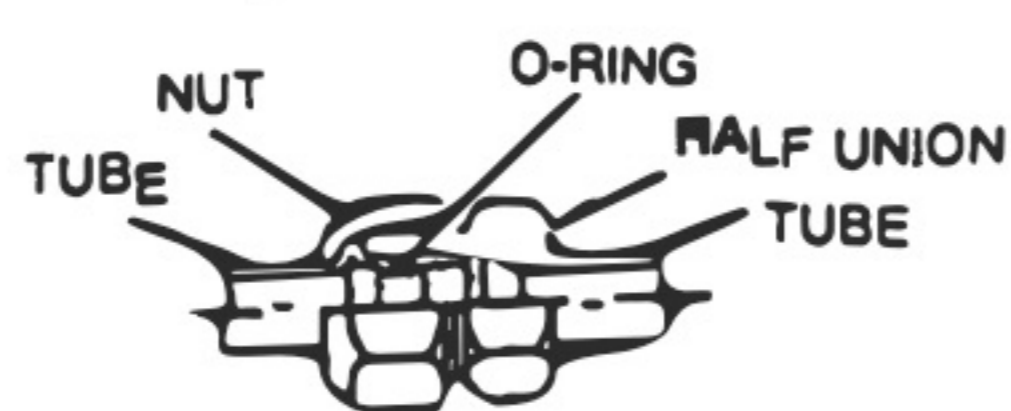
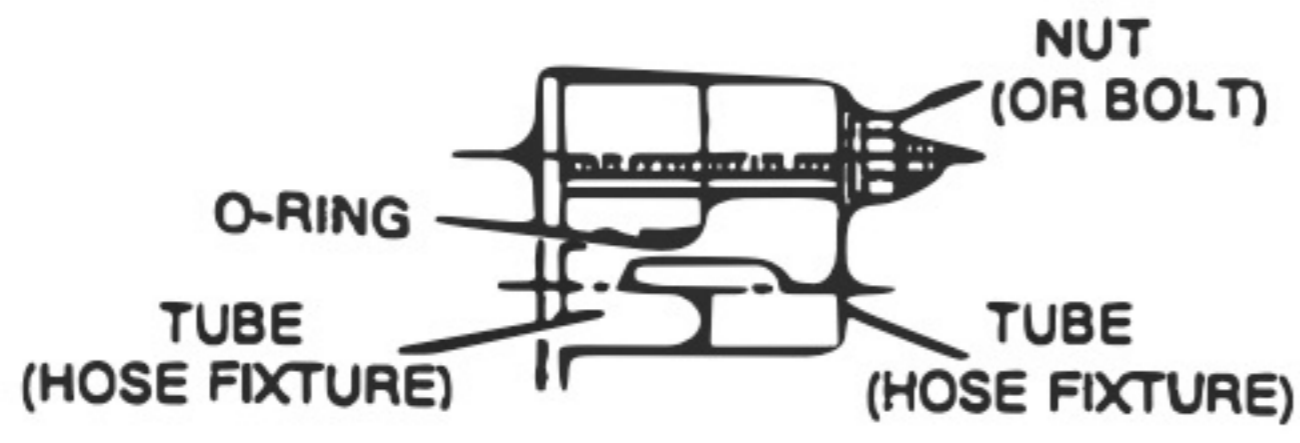

**[TIGHTENING TORQUE TABLE (FOR PIPES)]**

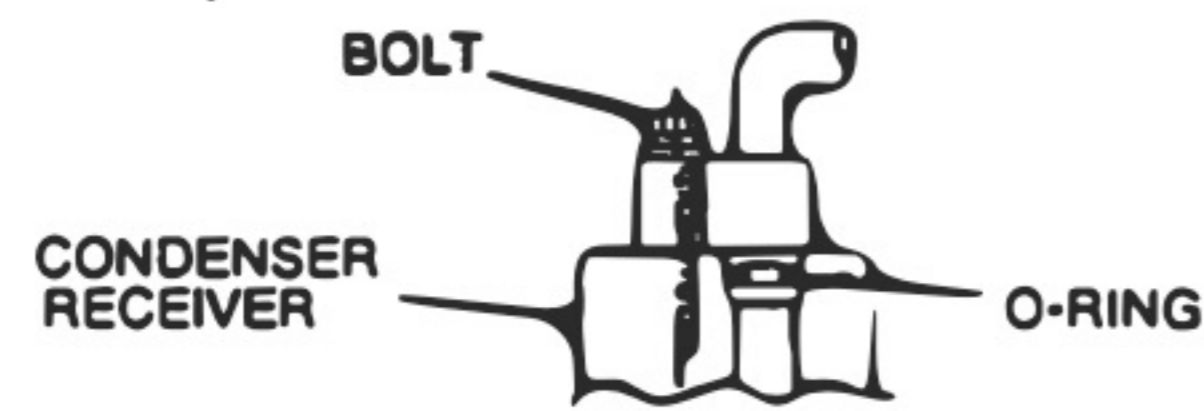
STRUCTURE	TUBE SIZE	TIGHTENING TORQUE		
		N•m	kgf•cm	ft•lbf
<p>&lt;GENERAL PIPING (UNION TYPE)&gt;</p> 	<p>1/4"</p> <p>φ 8</p> <p>1/2"</p> <p>5/8"</p>	<p>7.8±1.0</p> <p>13.7±1.0</p> <p>22.5±2.0</p> <p>32.3±2.0</p>	<p>80±10</p> <p>140±10</p> <p>230±20</p> <p>330±20</p>	<p>5.8±0.7</p> <p>9.8±1.0</p> <p>16.2±1.7</p> <p>23.4±1.7</p>
<p>&lt;GENERAL PIPING (BOLT, NUT TYPE)&gt;</p> 	<p>BOLT &amp; NUT SIZE</p>	<p>N•m</p>	<p>kgf•cm</p>	<p>ft•lbf</p>
<p>&lt;COMPRESSOR&gt;</p> 				
<p>&lt;CONDENSER (EXCLUDING MF TYPE) COOLING UNIT&gt;</p> 				
<p>&lt;CONDENSER (MF TYPE)&gt;</p> 				

## 1-4 PRECAUTIONS FOR SAFETY INSTALLATION

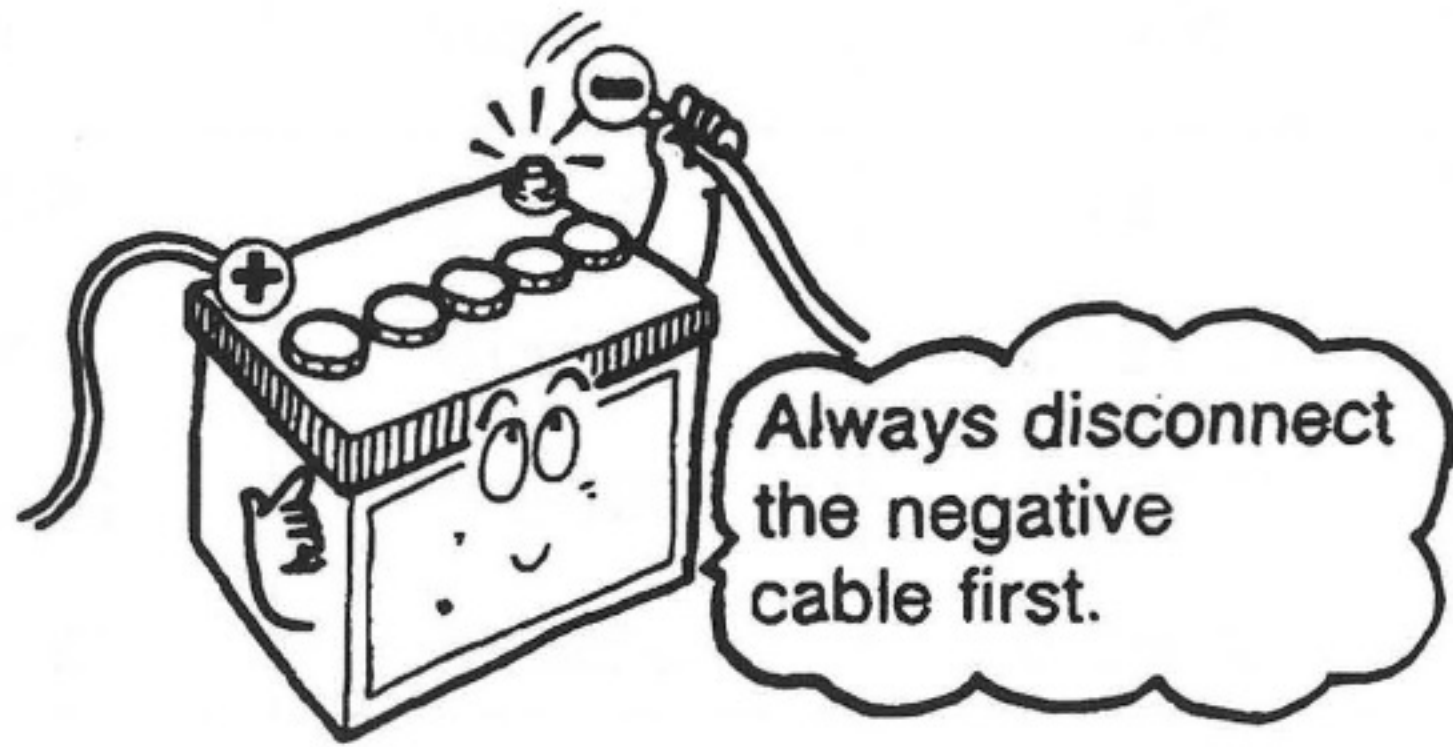

- (1) Never carry out installation with battery cables connected.

### NOTE

1. If installation is carried out with the power connected, a short-circuit may result.
2. Always disconnect the negative cable first.
3. When re-connecting the cables, make sure to connect the correct terminal of the battery with it.



- (2) Do not smoke or expose open flame near the vehicle during installation.

### NOTE

Pay special attention when working on the fuel system.

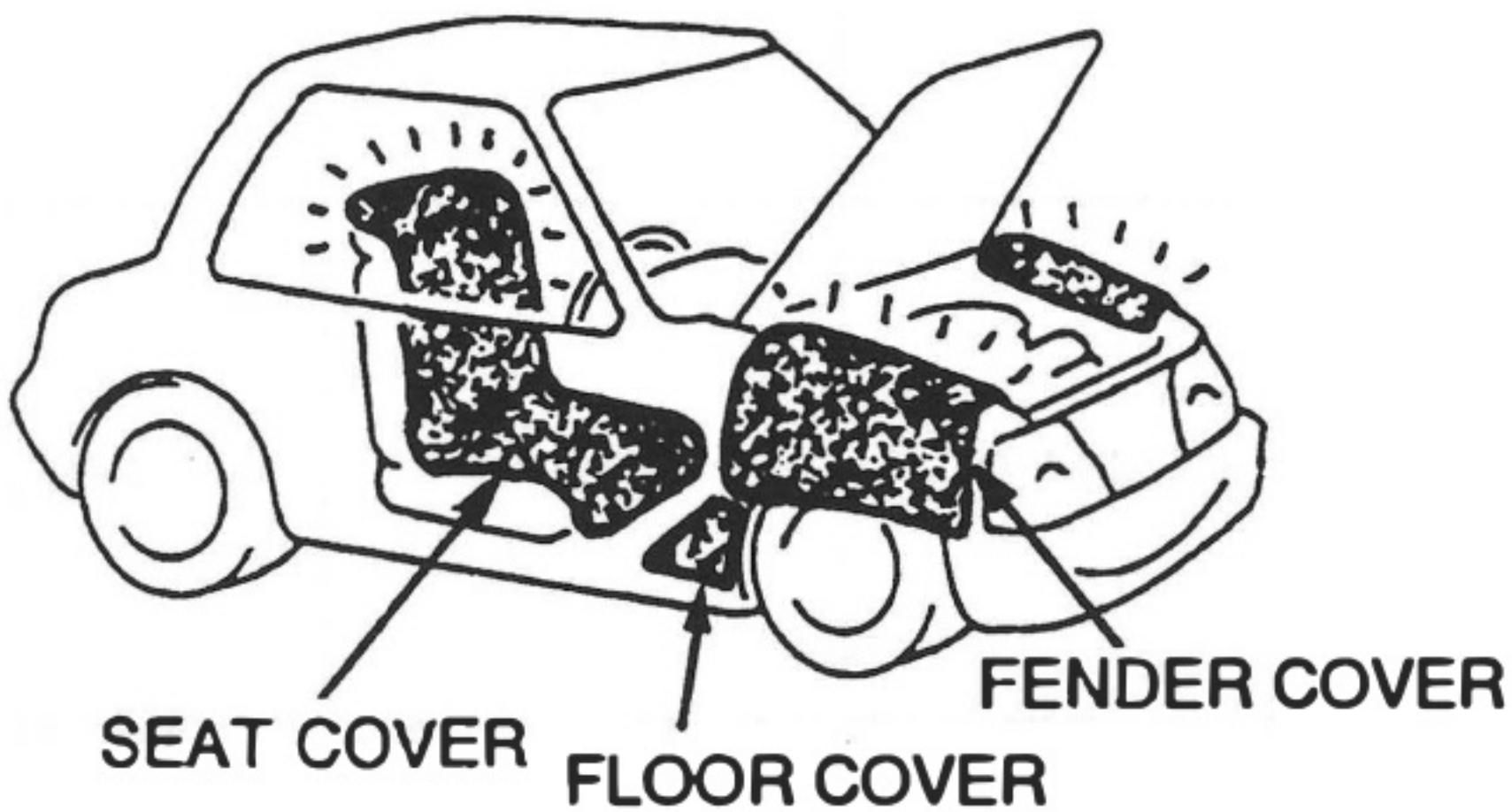

- (3) Use protective covers to avoid damage to the vehicle and the air conditioning parts.

- Seat cover
- Fender cover
- Floor cover

TORQUE WRENCH

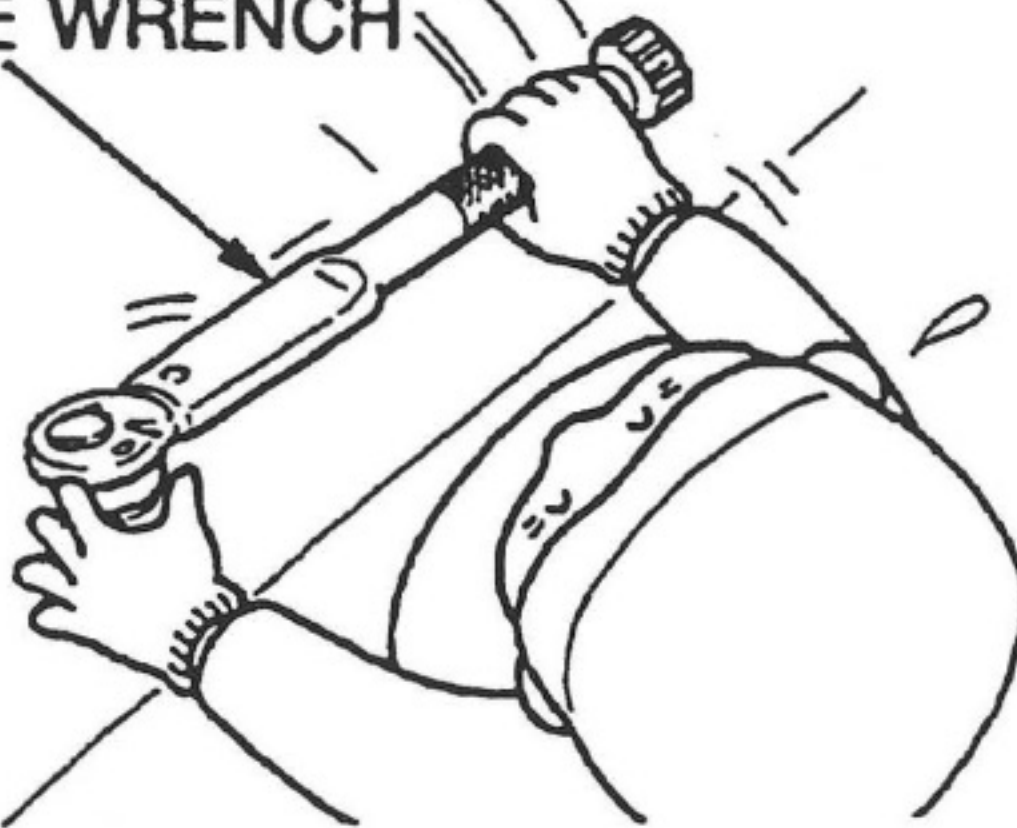

- (4) The bolt where specified must be torqued to proper specification. If torque is not specified, refer to TIGHTENING TORQUE TABLE on page 2.

SLOT SCREWDRIVER

VINYL TAPE

CLIP REMOVER

- (5) Take care not to scratch any part of the vehicle. Bind the tips of tools (clip remover, slot screwdriver etc.) with a piece of vinyl tape to prevent damage to parts of the vehicle.

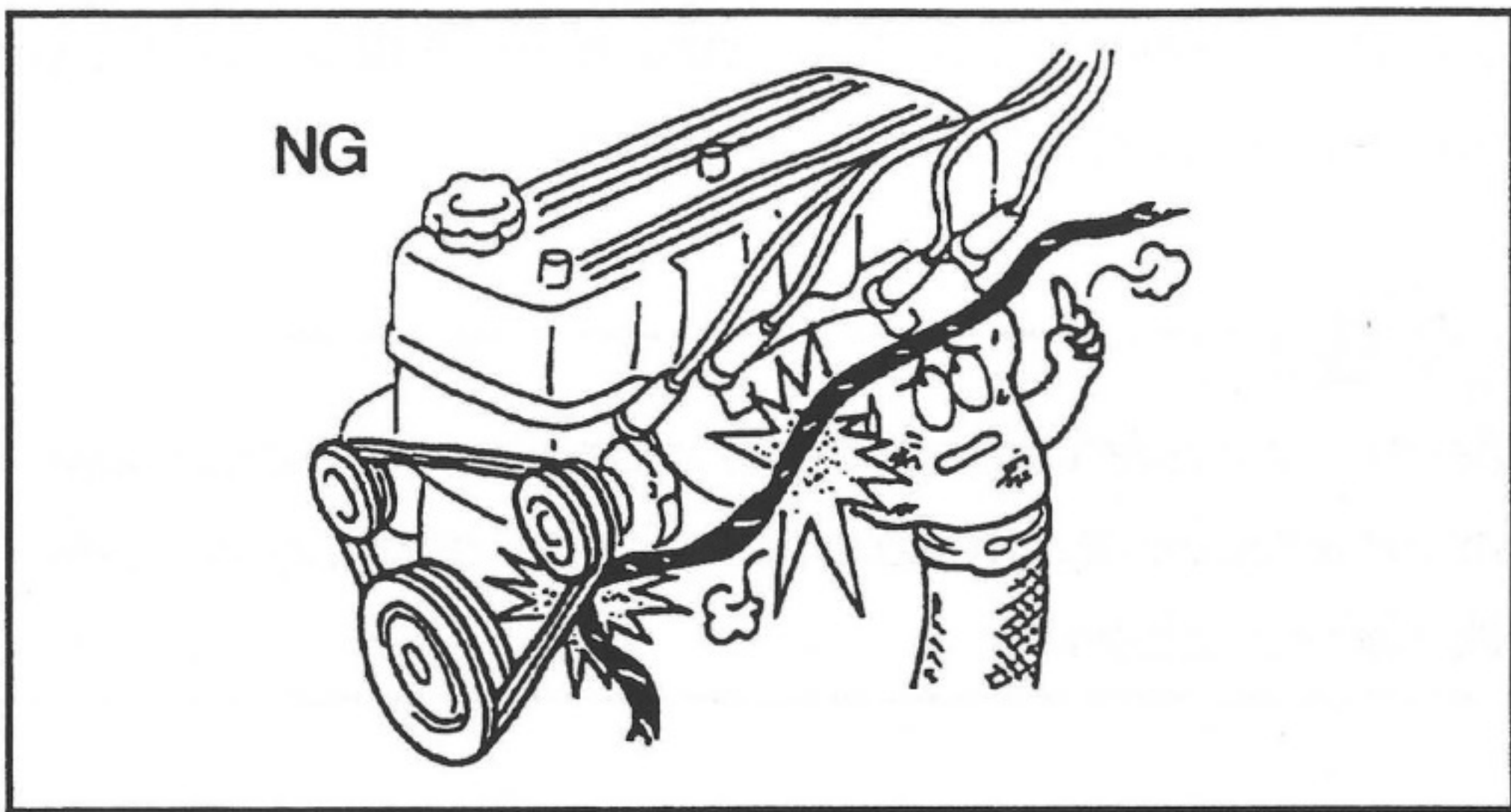

(6) When installing the A/C harnesses, route properly avoiding interference with surrounding parts.

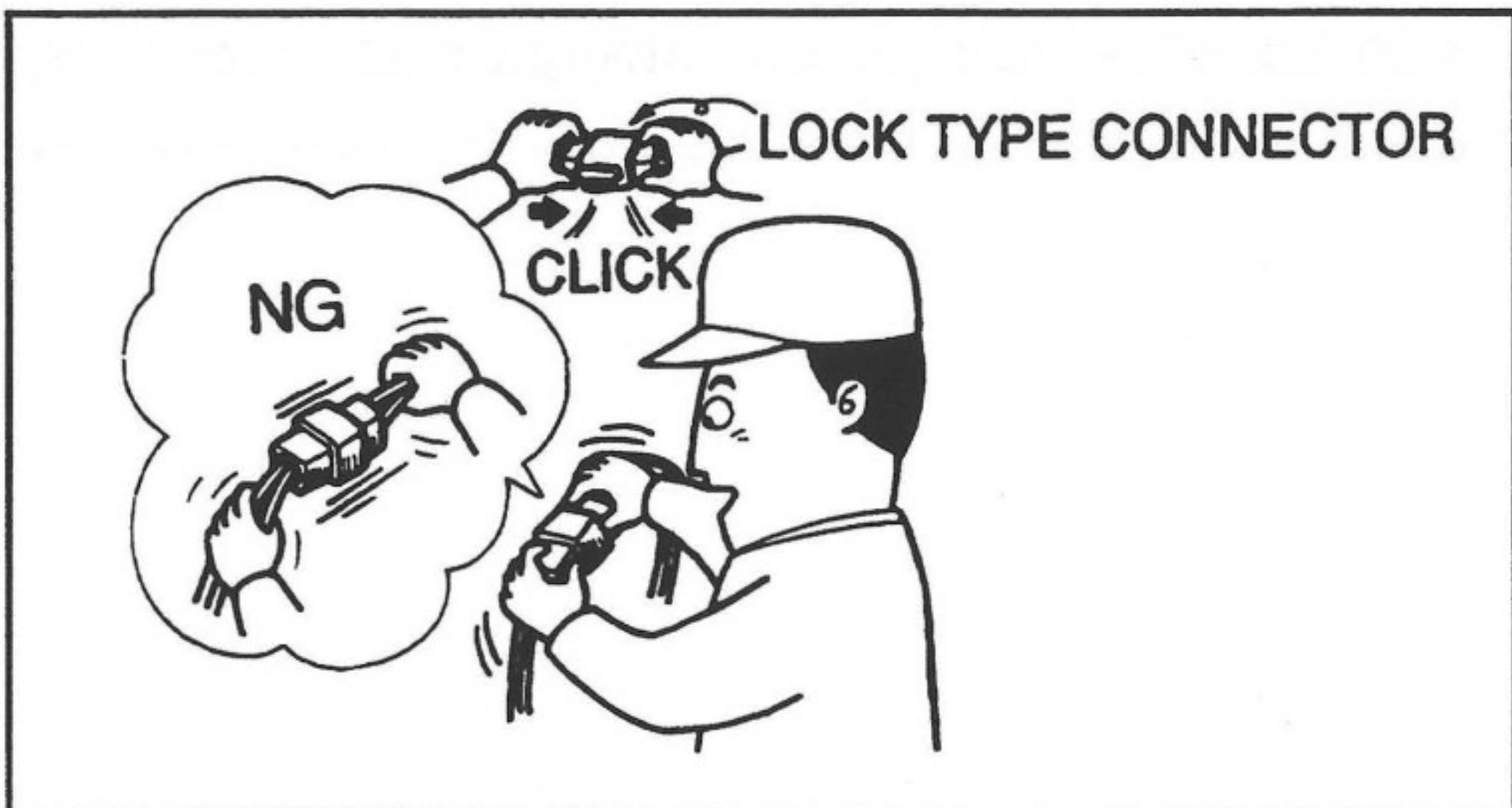

(7) Do not pull on vehicle wires and/or wire harnesses. To uncouple electrical connectors, pull only on the connector itself so as not to damage.

**NOTE**

*In the case of lock type connectors, make sure that the connectors are unlocked before disconnecting. When re-connecting the connectors, insert them until a clicking noise is heard. After they are connected, hold and pull them gently to check that they are connected properly.*

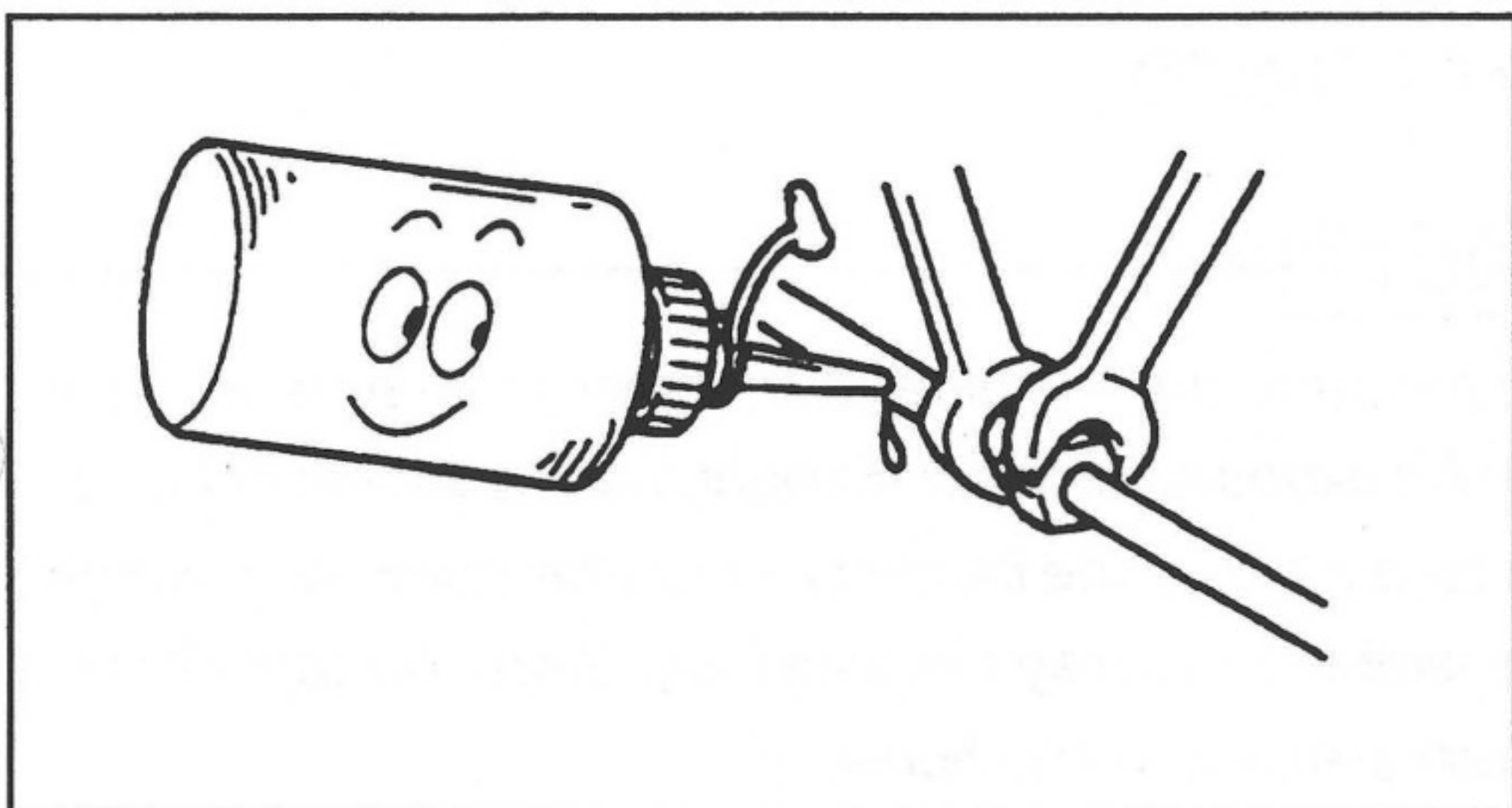

(8) Before making any hose and tube connections, apply a few drops of compressor oil to the seat of O-ring to avoid refrigerant leakage.

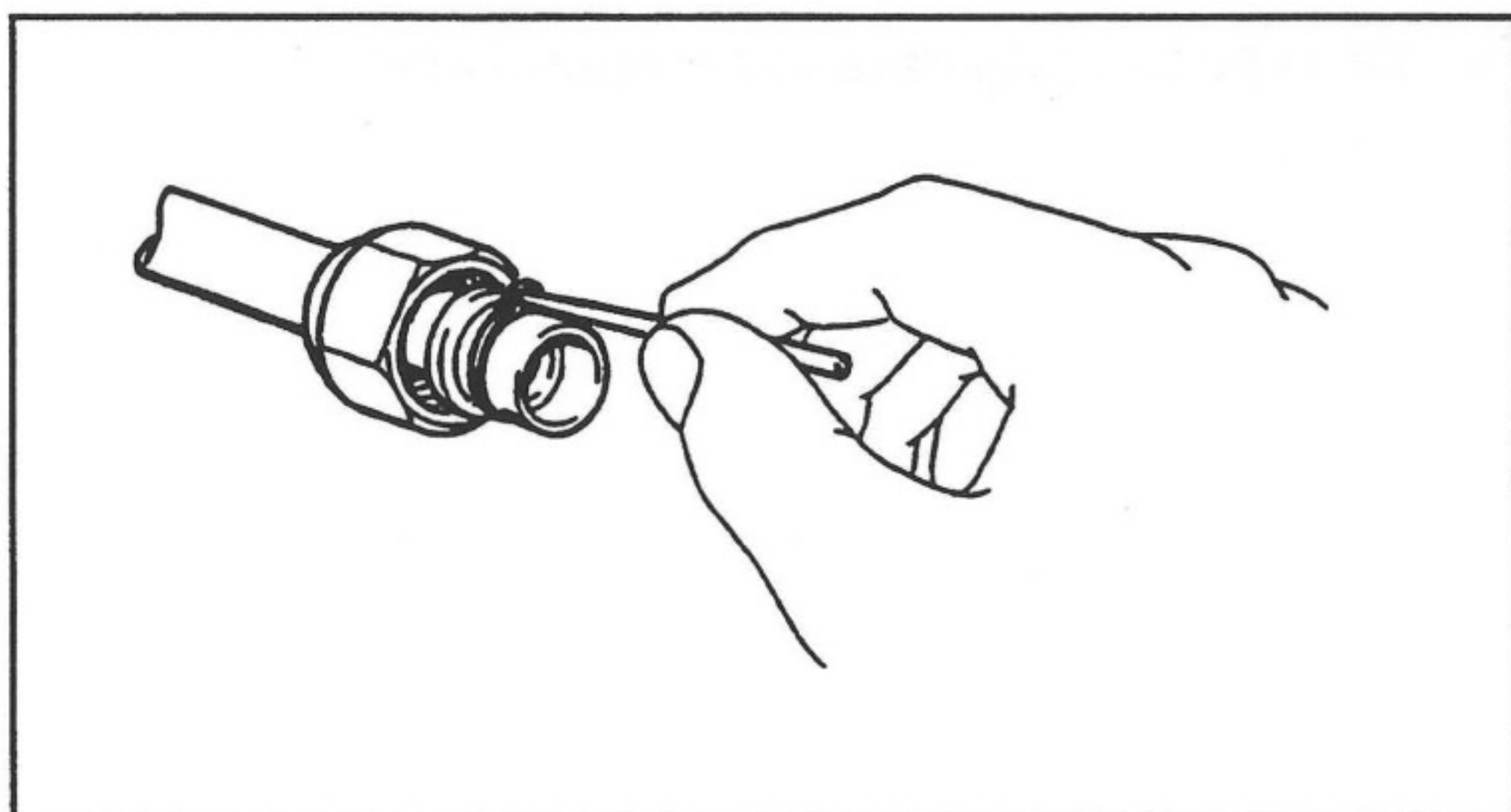

(9) When removing an O-ring from a tube, use a wooden or nylon awl to prevent damaging the tube.

**NOTE**

*Always replace the existing O-rings with new ones specified for refrigerant HFC-134a.*

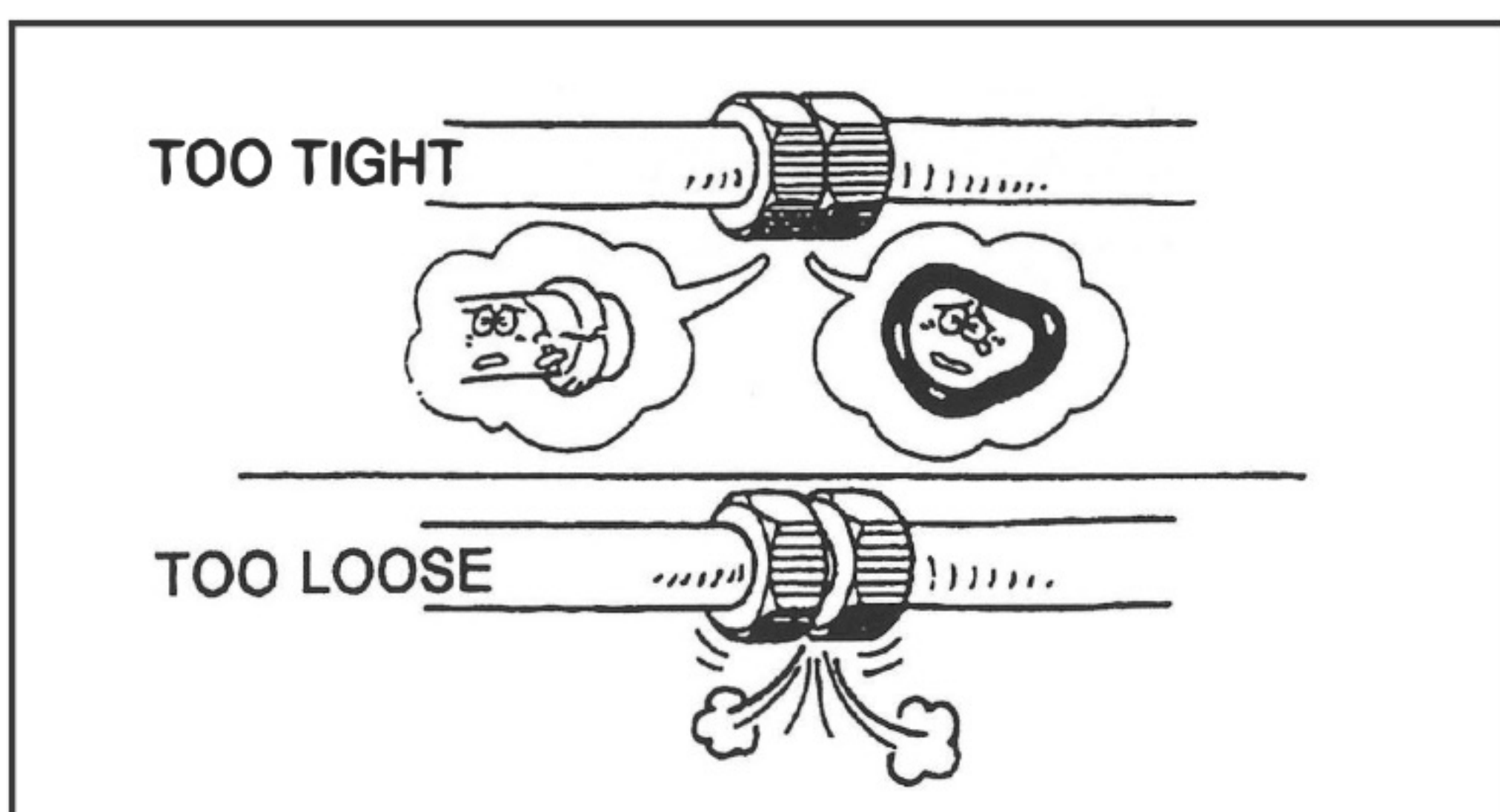

(10) When tightening or loosening fittings, use two wrenches to prevent the tubes from twisting. After loosening the fittings, tighten them with specified torque.

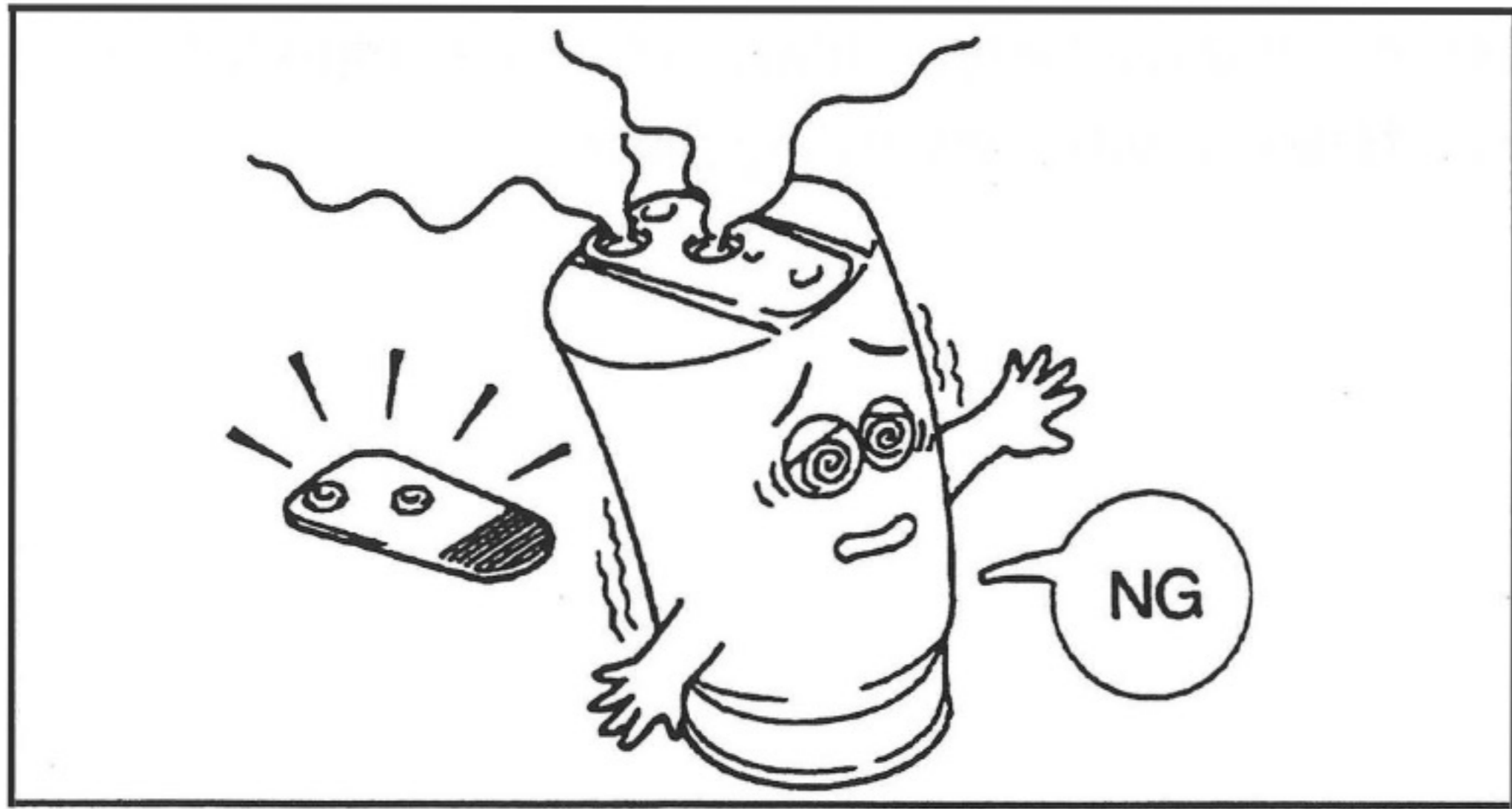

(11) Do not remove protective caps from fittings until each component is ready for connection.

**NOTE**

*If the receiver is left uncapped for a long time, the desiccant inside the receiver may absorb moisture, causing damage to the air conditioning.*



(12) When handling refrigerant, always wear proper eye protection and do not allow it to come in contact with skin.

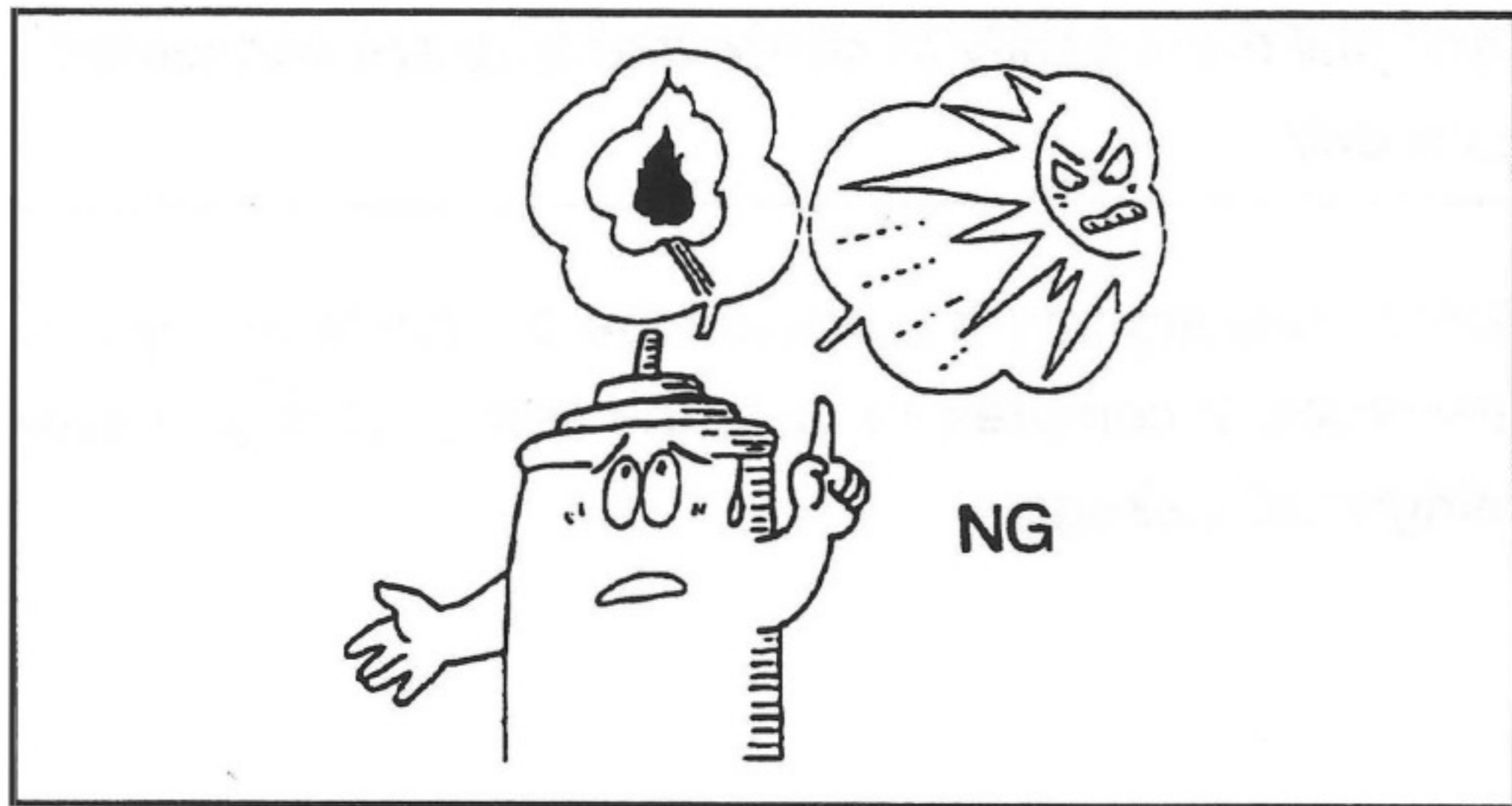

(13) Always keep the refrigerant container (service drum) below 40°C (104 °F).

**NOTE**

*Do not store the refrigerant container in an area where it can be exposed to direct sunlight, near a source of fire, or an area such as the inside of a car (the trunk etc.), where the temperature may become high. Store the container in a dark place with low-humidity.*



(14) Do not expose refrigerant to an open flame.

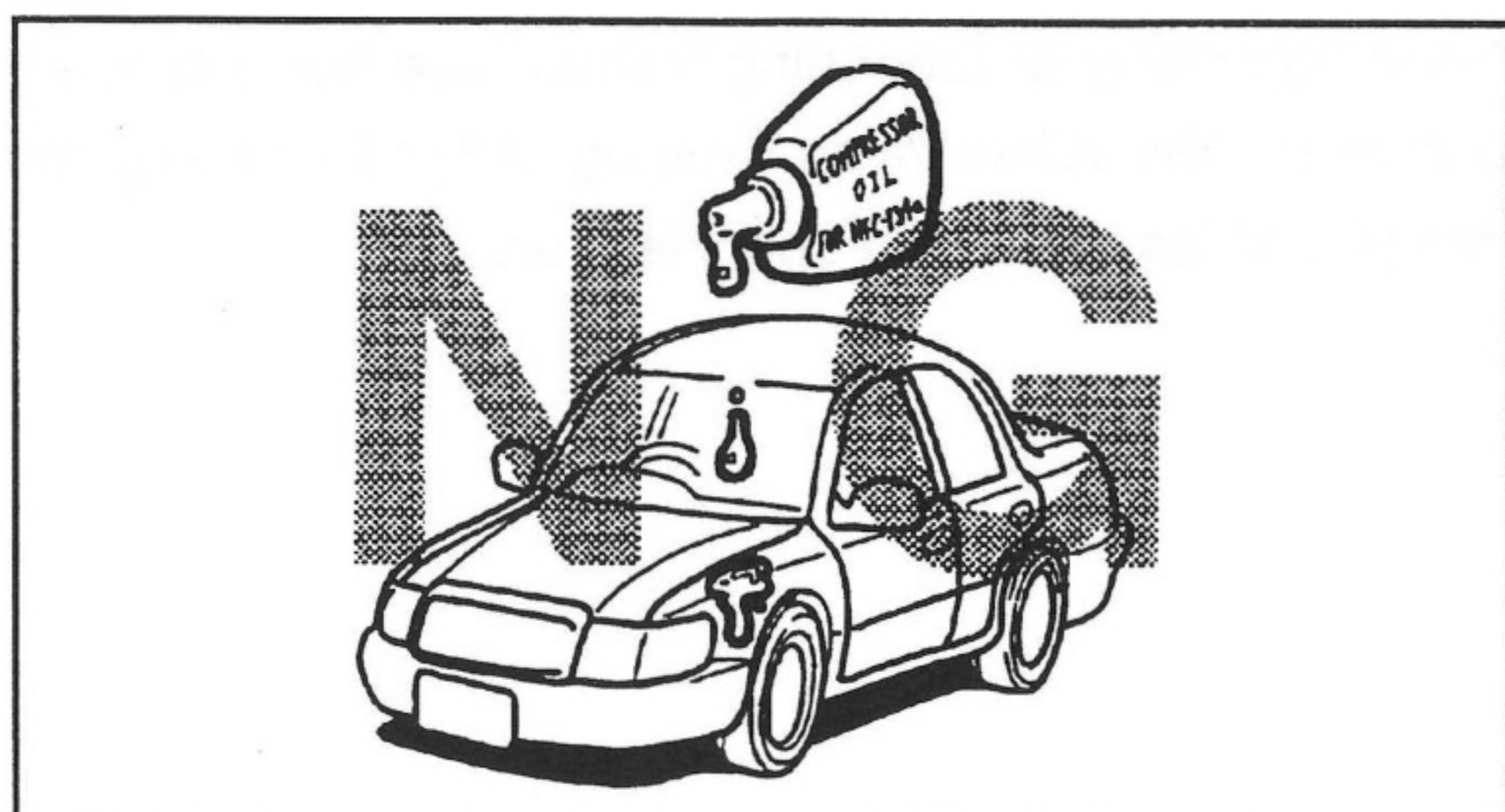

(15) Do not drop compressor oil (ND-OIL 8, 9) onto the vehicle surface. It causes the discoloration of the vehicle's body surface, or deterioration of the acrylic or ABS plastic components.

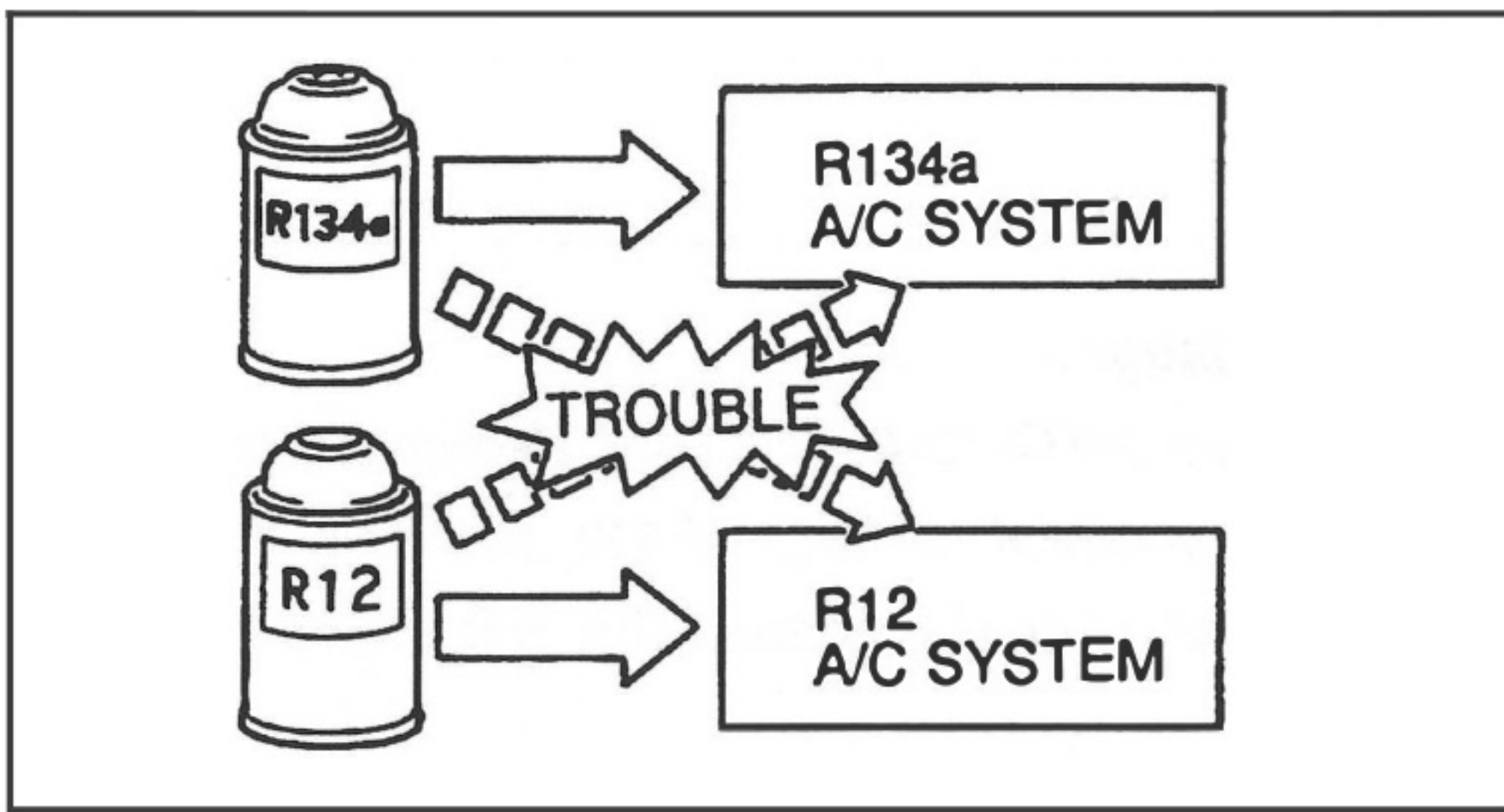

(16) Use the proper refrigerant HFC-134a (R134a).

**NOTE**

*The very different characteristics of refrigerants HFC-134a (R134a) and CFC-12 (R12) have determined the design of their respective air conditioning systems. Under no circumstances allow CFC-12 (R12) to enter an HFC-134a (R134a) system, or vice versa, because serious damage could occur.*



(17) Use the proper compressor oil.

**NOTE**

*Compressor oil used in conventional CFC-12 (R12) air conditioning systems cannot be used in HFC-134a (R134a) air conditioning systems.*

For a swash plate type compressor : ND-OIL 8  
 For a through vane type compressor: ND-OIL 9

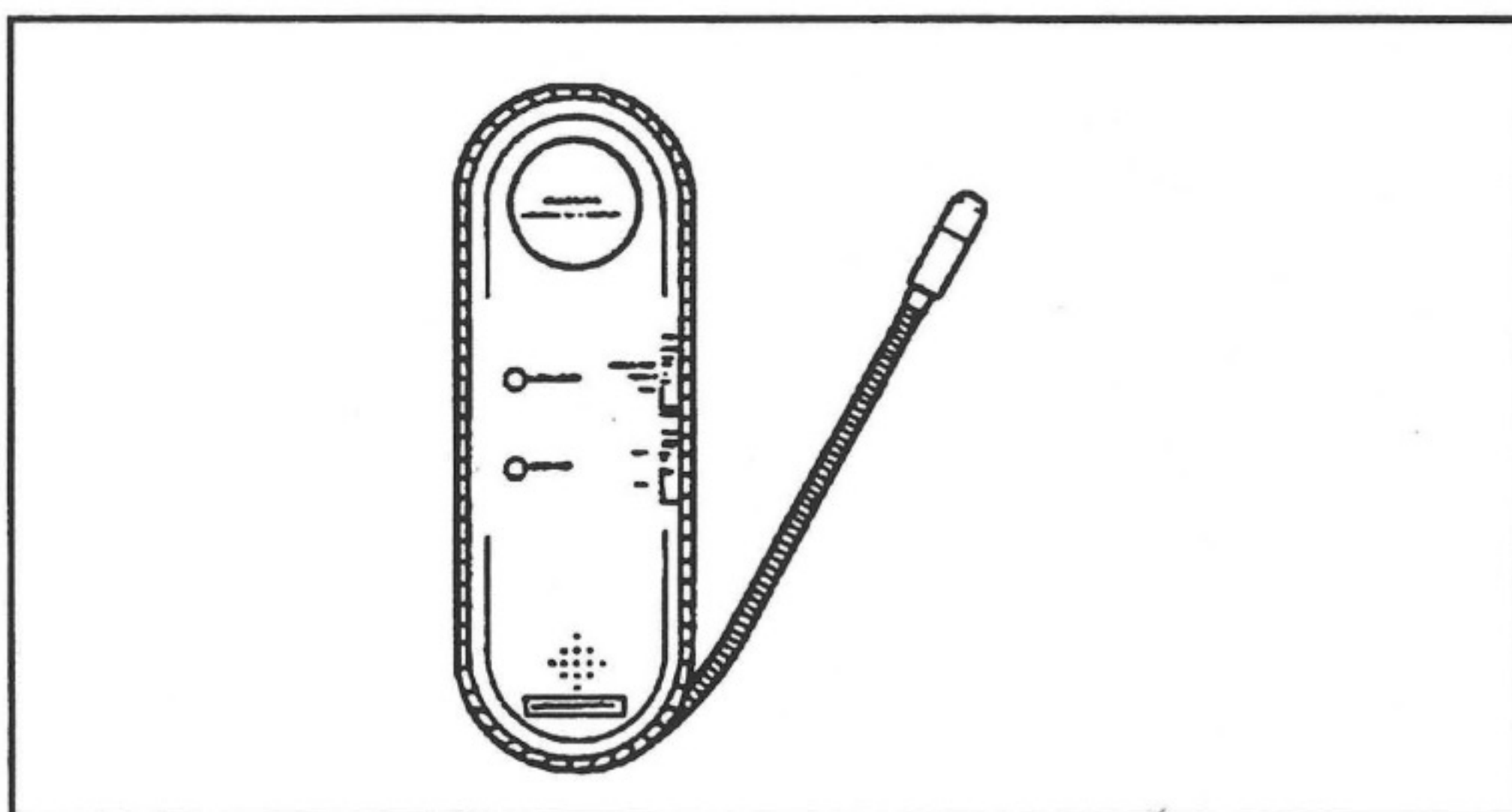

(18) Use an HFC-134a (R134a) gas leak detector.

**NOTE**

*The CFC-12 (R12) leak detector is not sensitive enough to detect HFC-134a (R134a).*

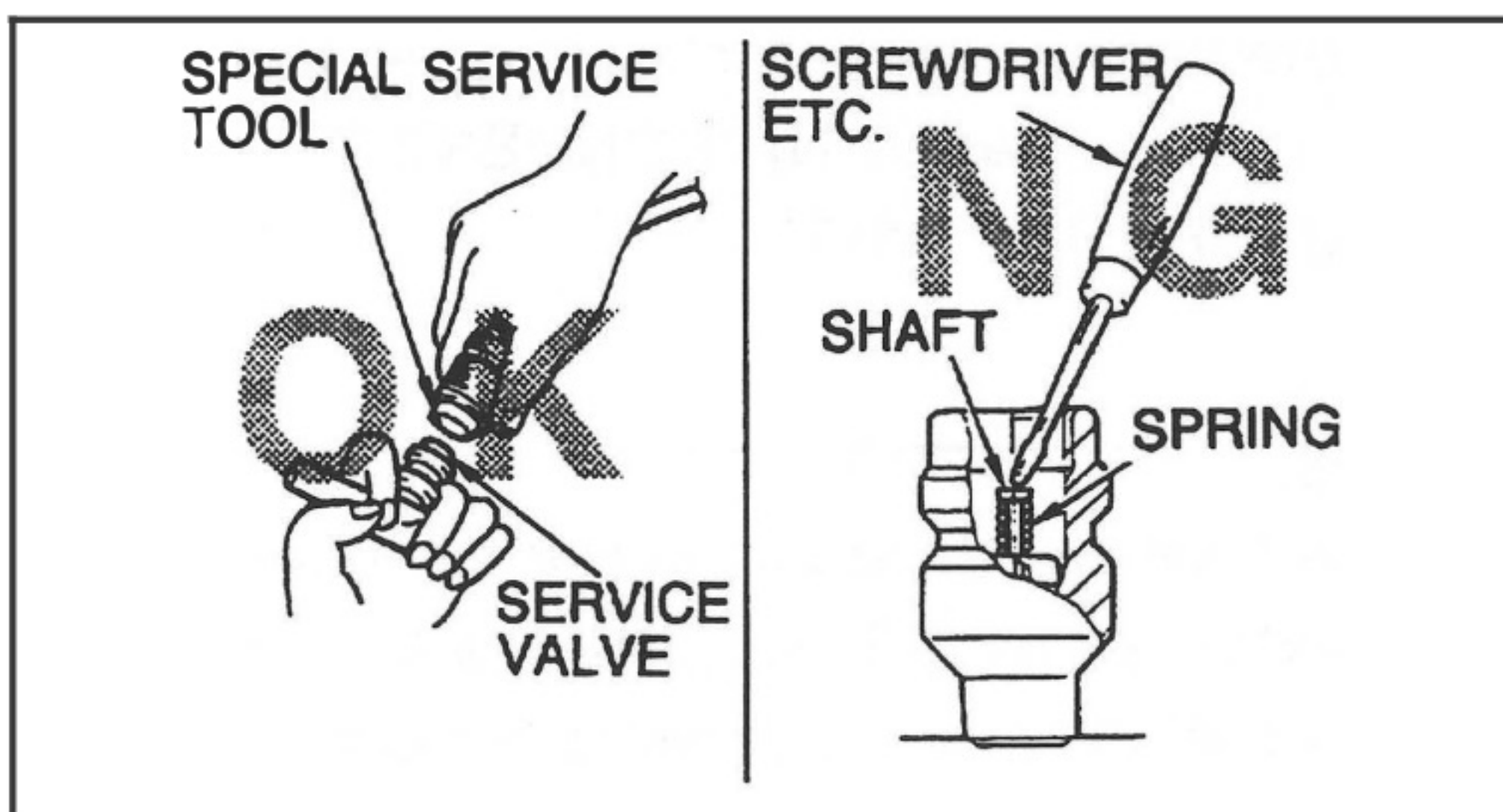

(19) When recovering refrigerant, use the necessary special service tools.

**NOTE**

- 1. Support the service valve by hand to prevent the tube from bending when connecting the charging hose.*
- 2. Using a general tool like a screwdriver may cause refrigerant leak by damaging the service valves.*

(20) Use manifold gauges for HFC-134a (R134a).

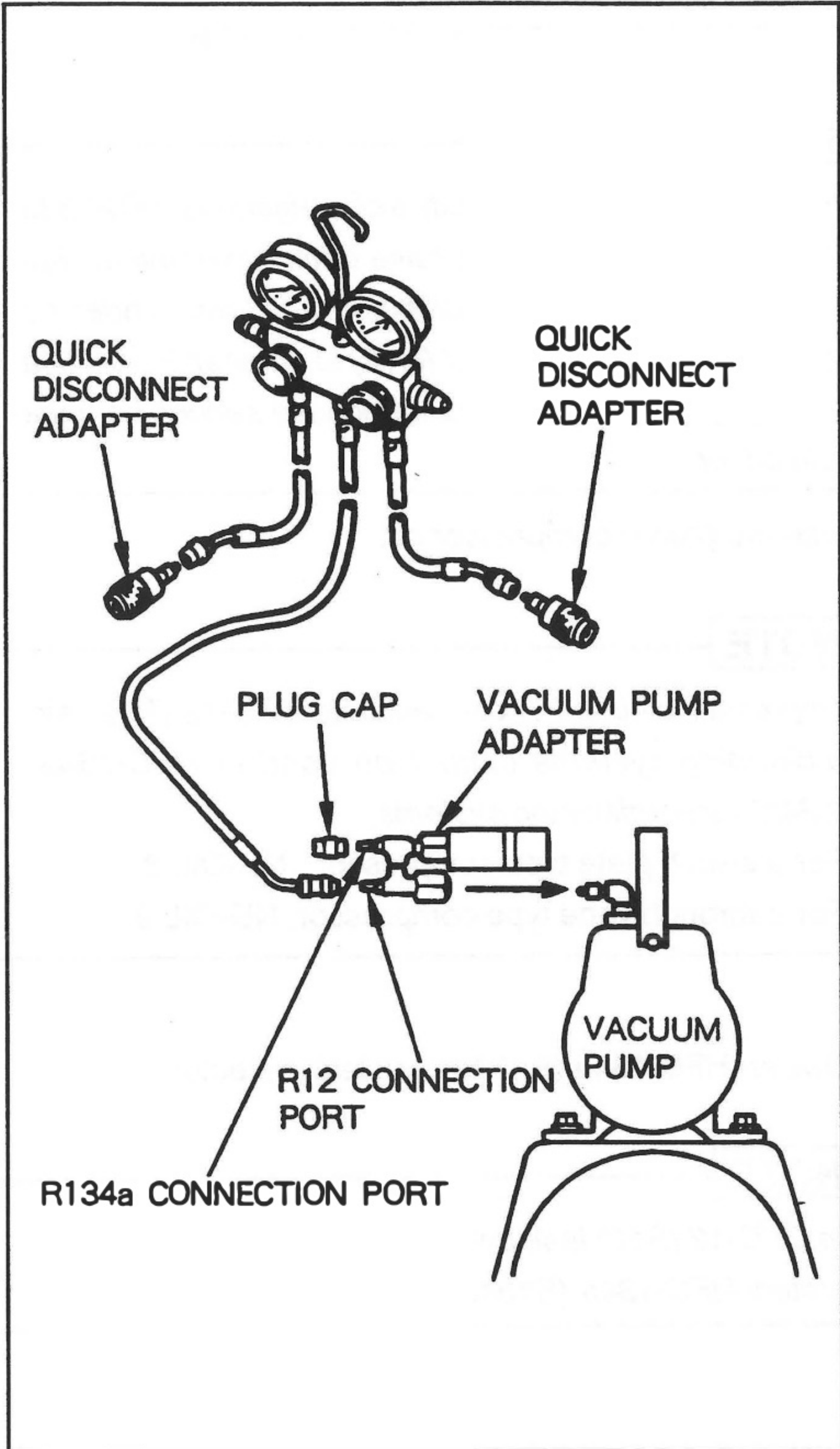

**NOTE**

1. *Manifold gauges*  
Always use HFC-134a (R134a) dedicated manifold gauges to prevent CFC-12 (R12) and CFC-12 (R12) compressor oil contaminating the HFC-134a (R134a) system.
2. *Vacuum pump adapter*
  - (1) *By connecting a vacuum pump adapter, the vacuum pump can be used for both HFC-134a (R134a) and CFC-12 (R12) air conditioning systems.*
  - (2) *Be sure to turn off the manifold gauge valve immediately after evacuating the system, then switch off the vacuum pump. If this order is reversed, the line will be temporarily open to atmosphere.*

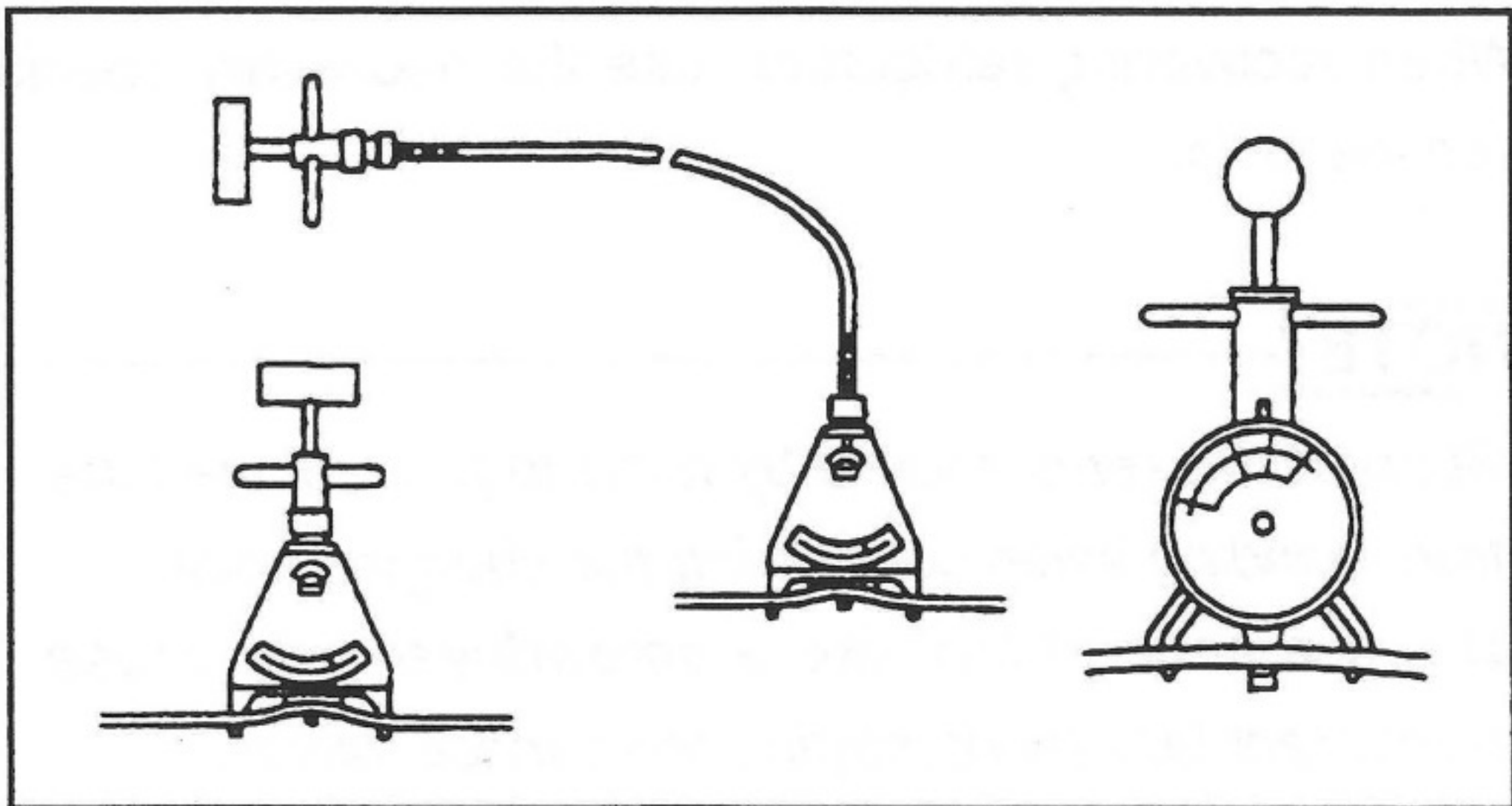

(21) After installing the drive belt, check the belt tension using a belt tension gauge NIPPONDENSO BTG-20 or BORROUGHS BT-33-73F.

**NOTE**

1. *The belt tension must be measured between the specified pulleys as indicated in the installation manual.*
2. *A "New belt" refers to a belt which has been used for less than 5 minutes of operation.*  
*A "Used belt" refers to a belt which has been used for more than 5 minutes of operation.*
3. *The drive belt requires accurate tension adjustment ; a slack belt is likely to cause the belt to whine, while excessive tension may result in damage to the bearings or the idle pulley bracket.*
4. *After installing the drive belt, make sure it is properly seated in the grooves of the pulley.*

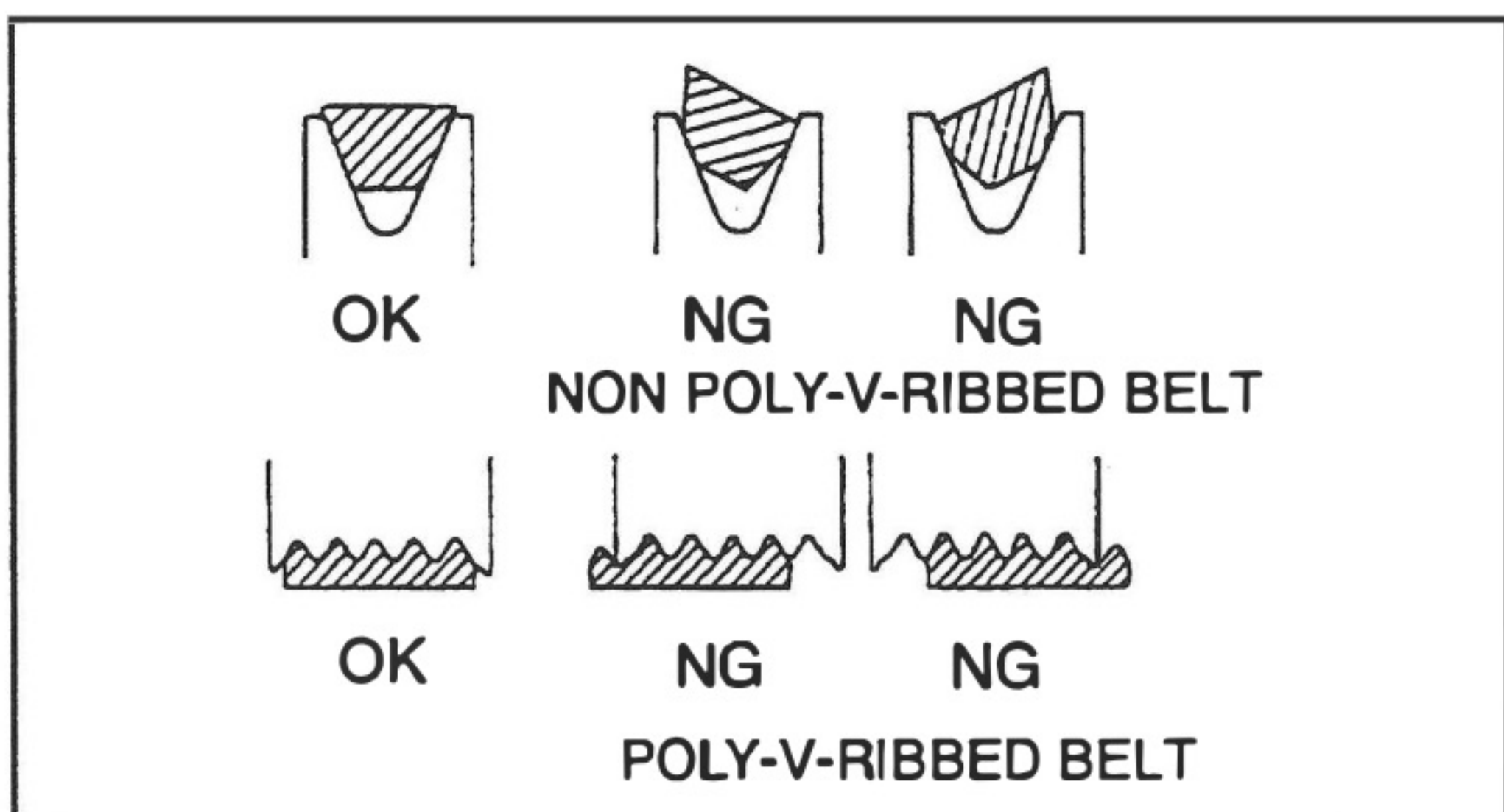

## 2. INSTALLATION

### ! CAUTION

1. Be sure to use the correct oil, refrigerant and charging/recovery equipment.
2. Before starting installation, read all "PRECAUTIONS FOR SAFETY INSTALLATION" thoroughly and follow the instructions described in it.
3. Before starting installation, remove the (-) terminal of the battery and ensure seat/floor covers are in position.
4. Take care not to scratch any parts of the vehicle.
5. Sort removed bolts and tapping screws into groups so that they can be reassembled correctly.

### 2-1 INSTALLATION INSIDE PASSENGER COMPARTMENT

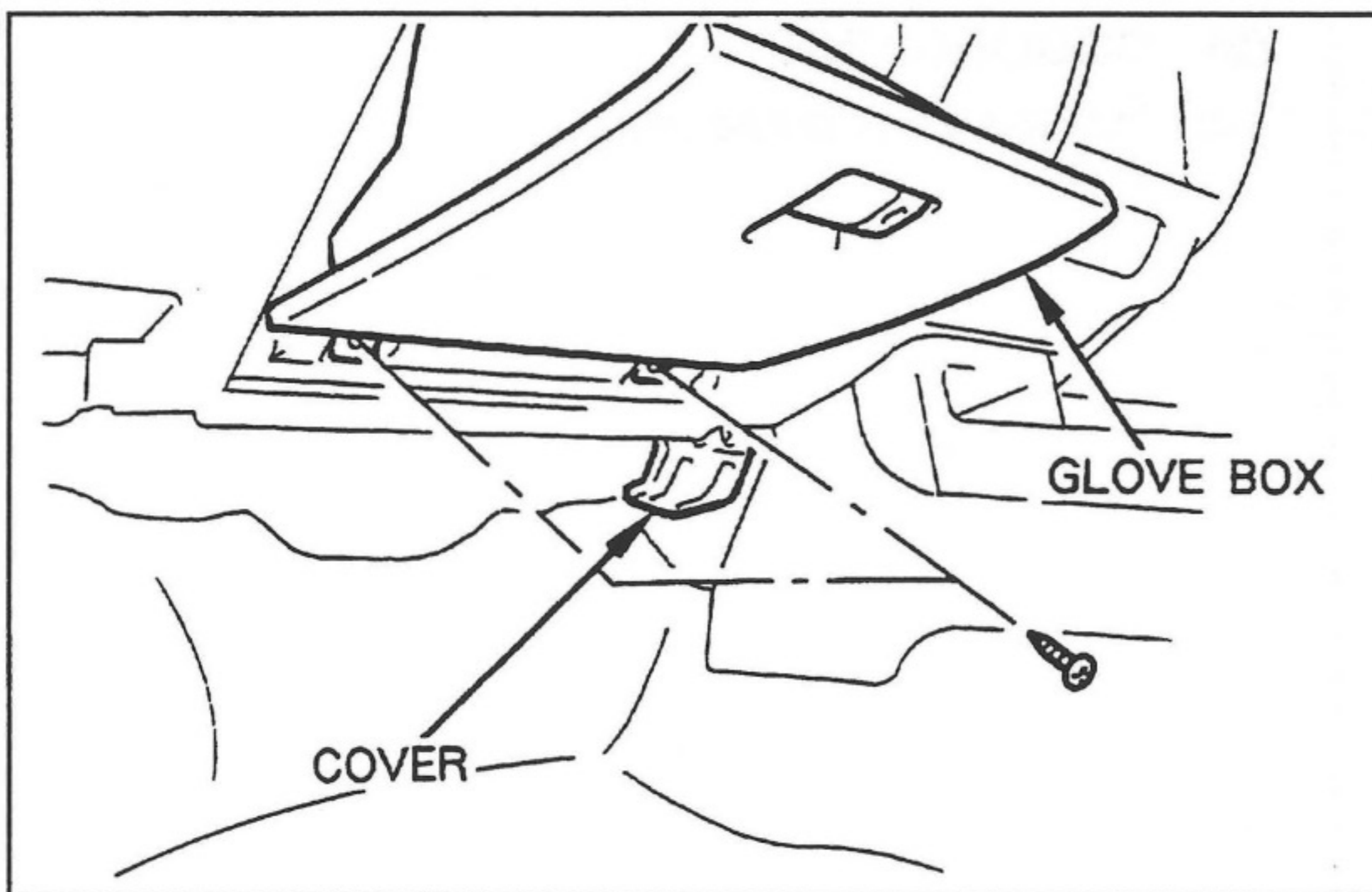

#### (1) REMOVAL OF PARTS

- (a) Glove box
- (b) Cover

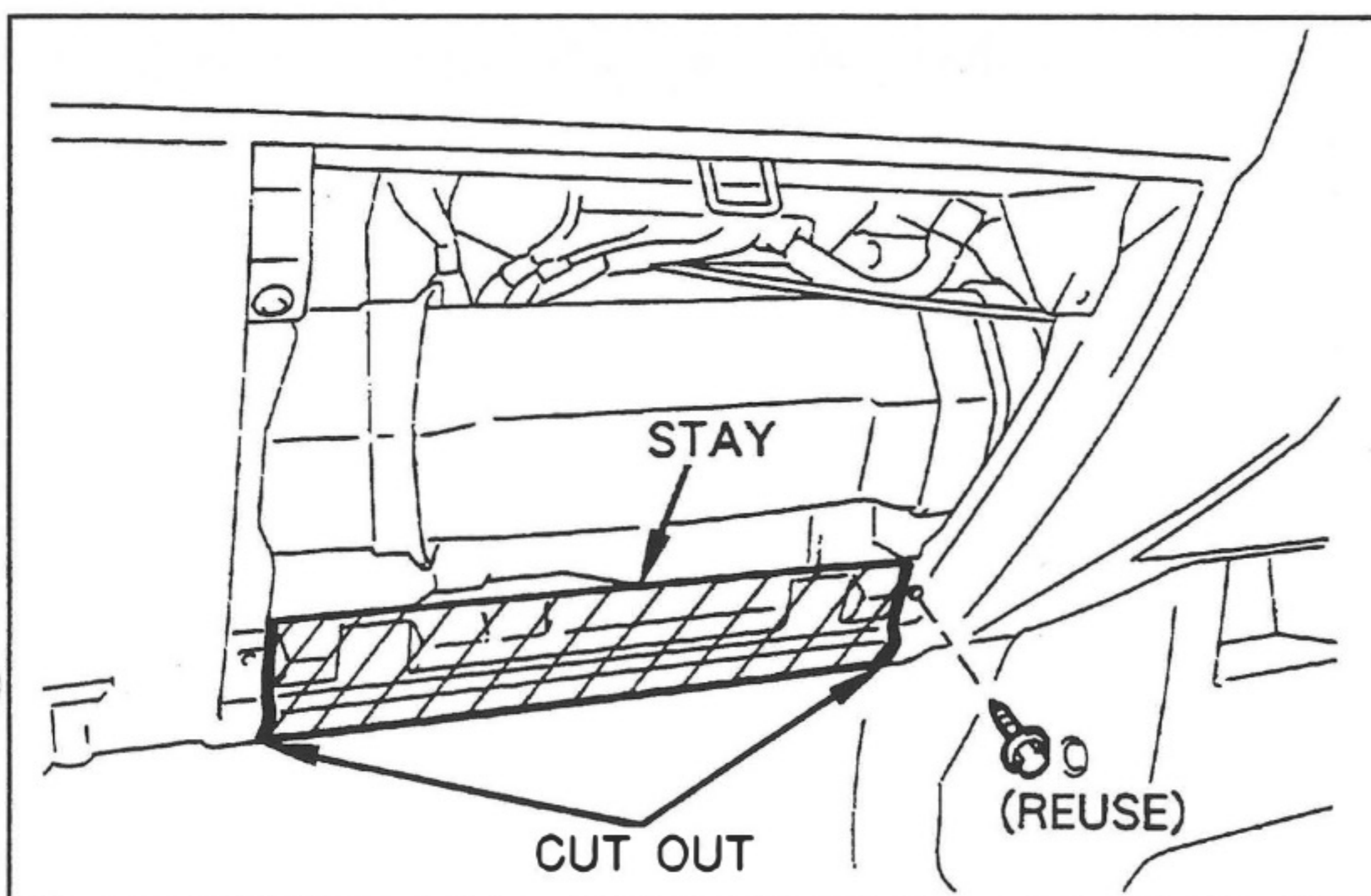

- (c) Cut out the stay

#### NOTE

Cut out the stay at the 10 mm from the side edge.

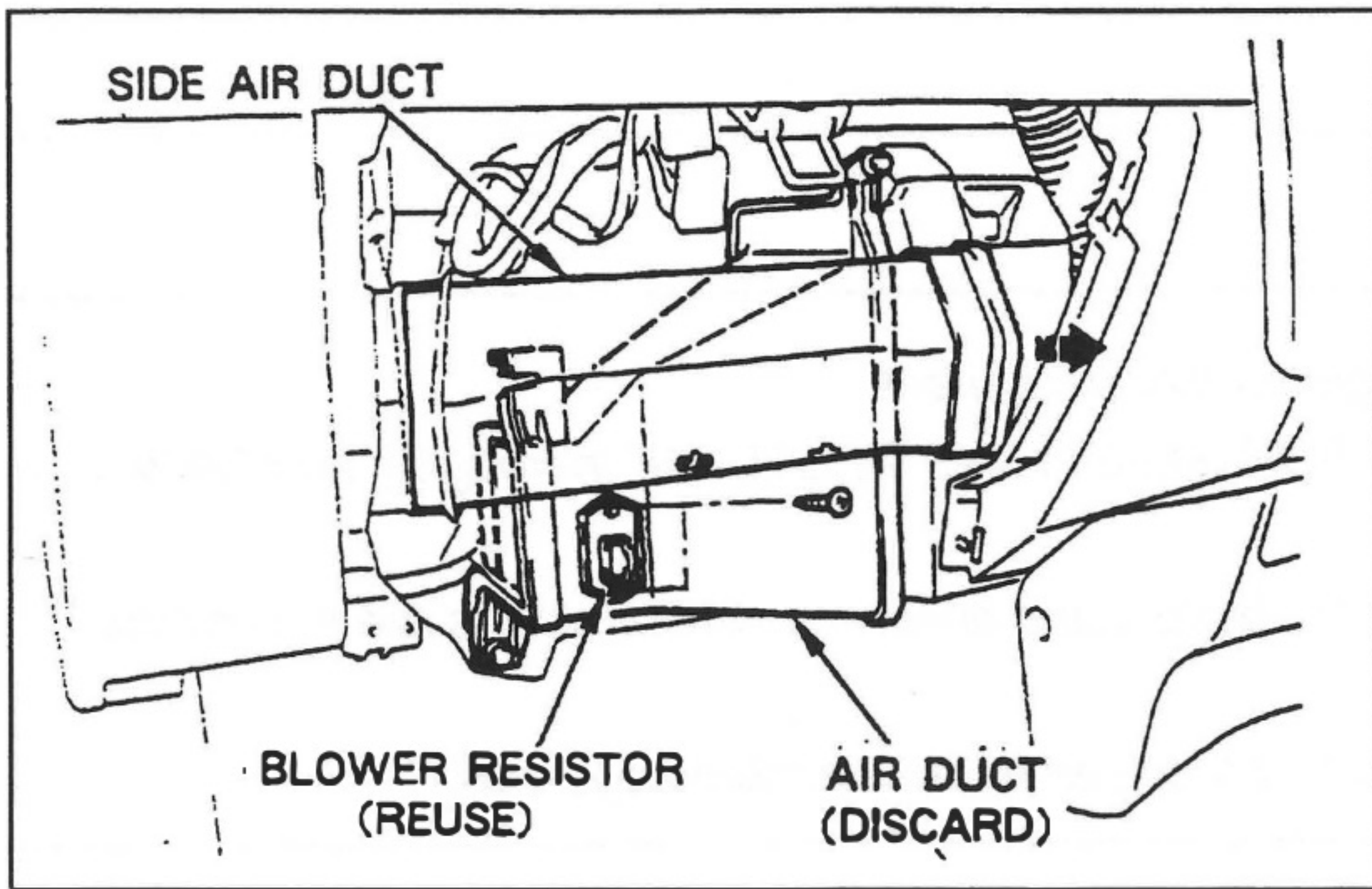

(d) Side air duct

**NOTE**

*Move the side air duct to the right hand side, then pull it.*

(e) Air duct (Discard)

(f) Blower resistor and tapping screws (Reuse)

**NOTE**

*Do not discard the three original tapping screws and the original bolt.*

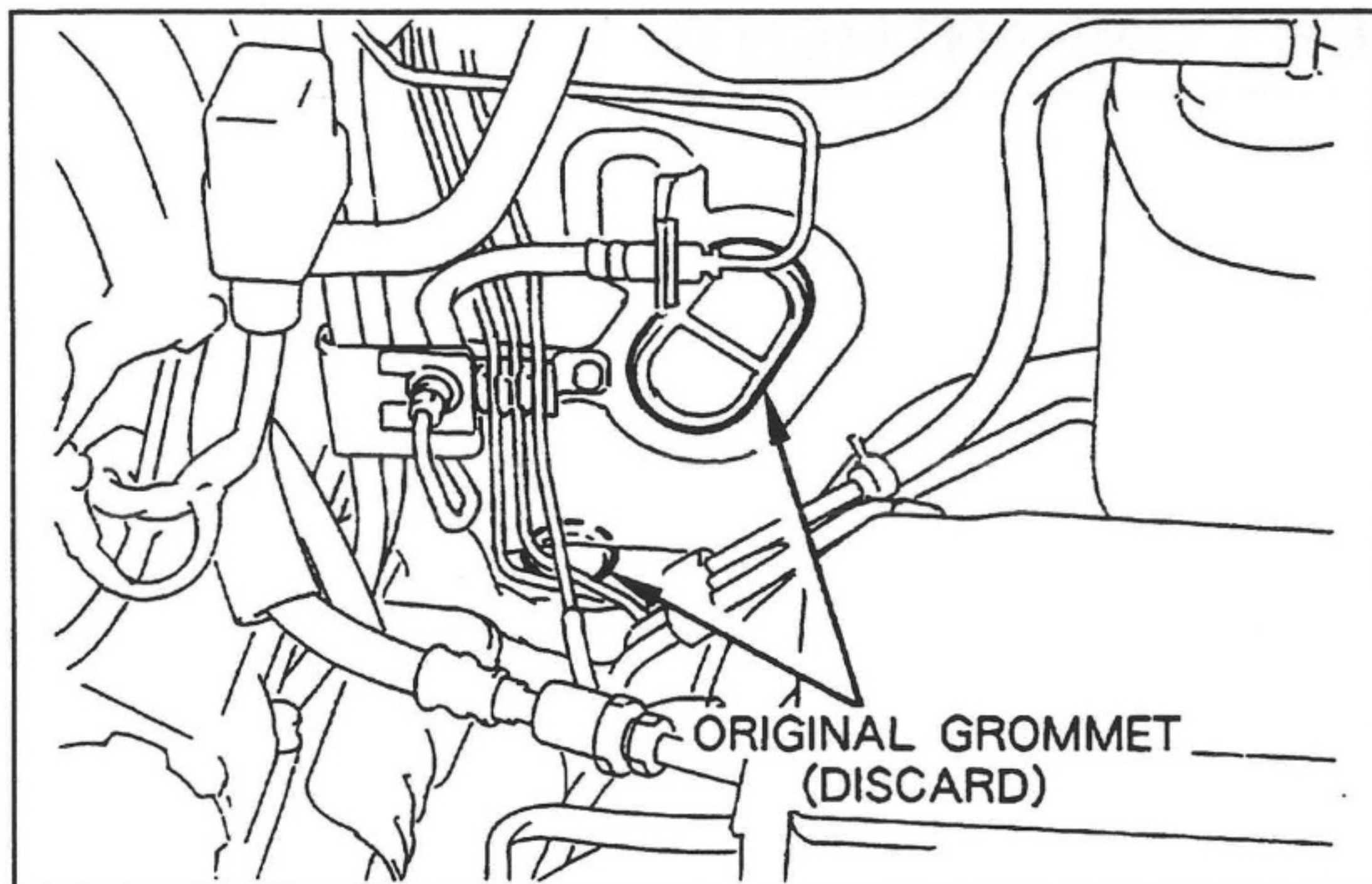

(g) Original grommets (Discard)

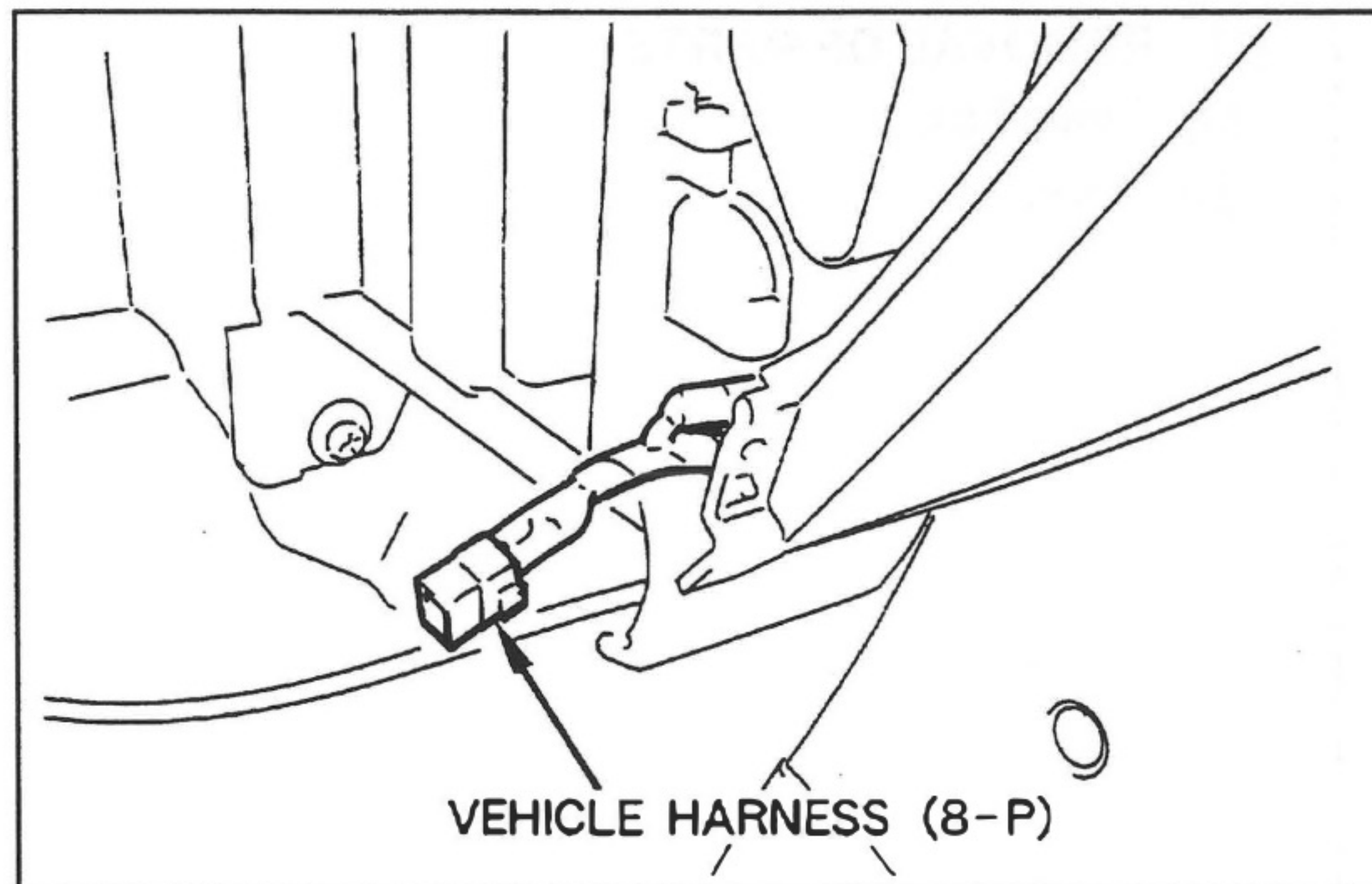

**(2) COOLING UNIT**

(a) Pull the vehicle harness.

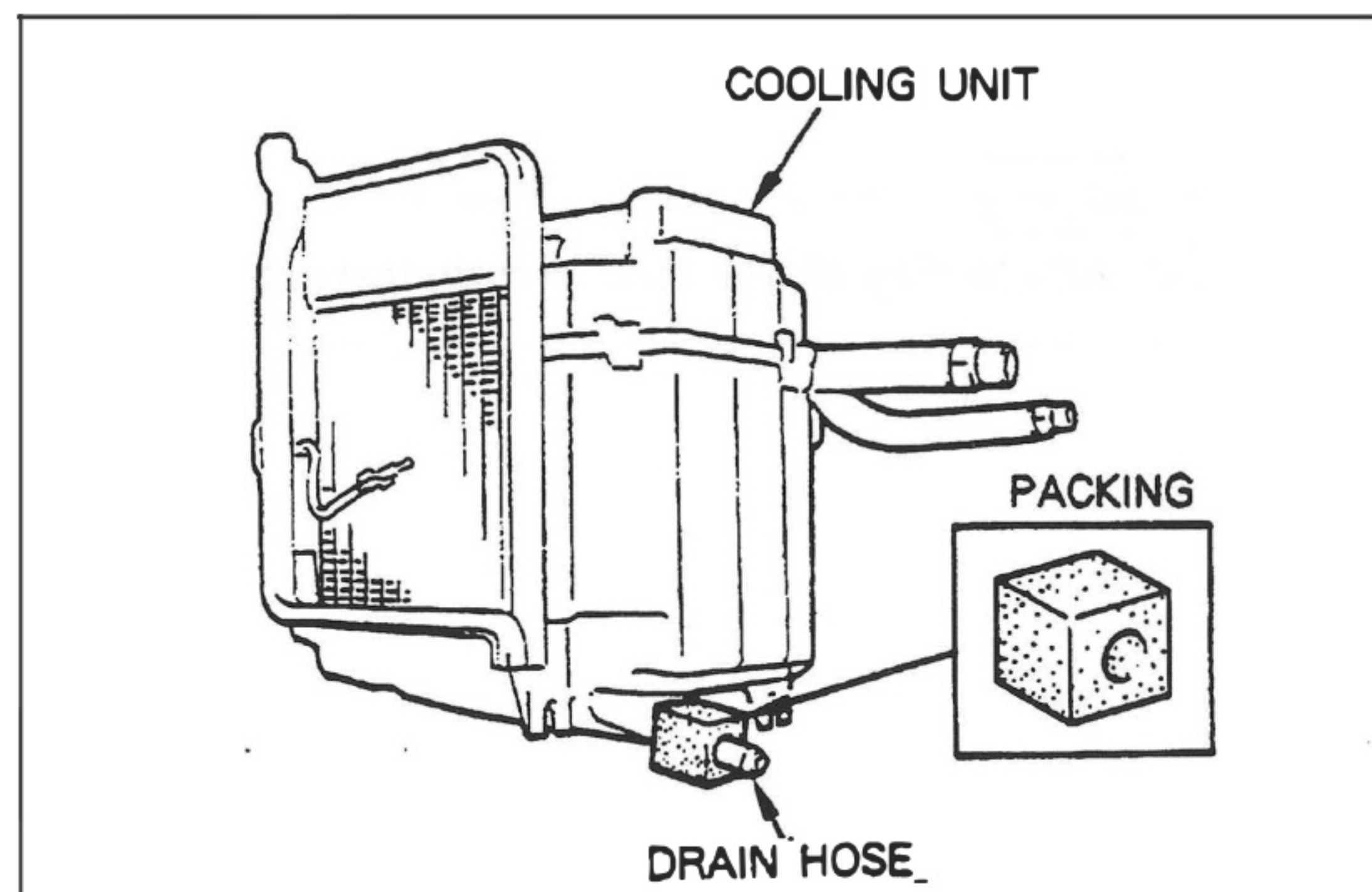

(b) Install the drain hose and packing to the cooling unit.

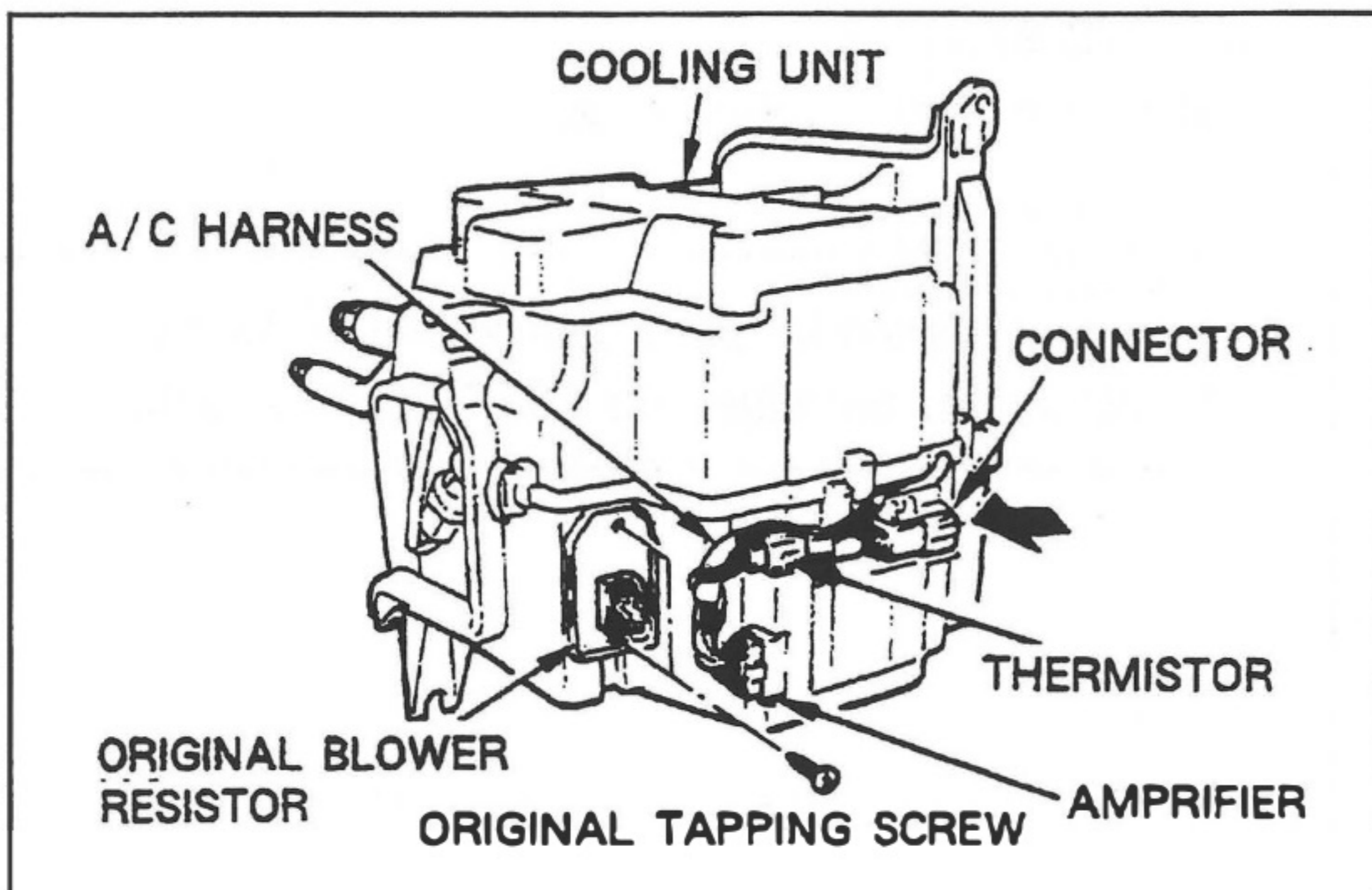

- (c) Install the original blower resistor to the cooling unit using two original tapping screws.
- (d) Install the connector of A/C harness to the cooling unit from the arrow direction.
- (e) Connect the A/C harness to the thermistor and the amplifier.

**NOTE**

*Route the A/C harness inside the thermistor.*

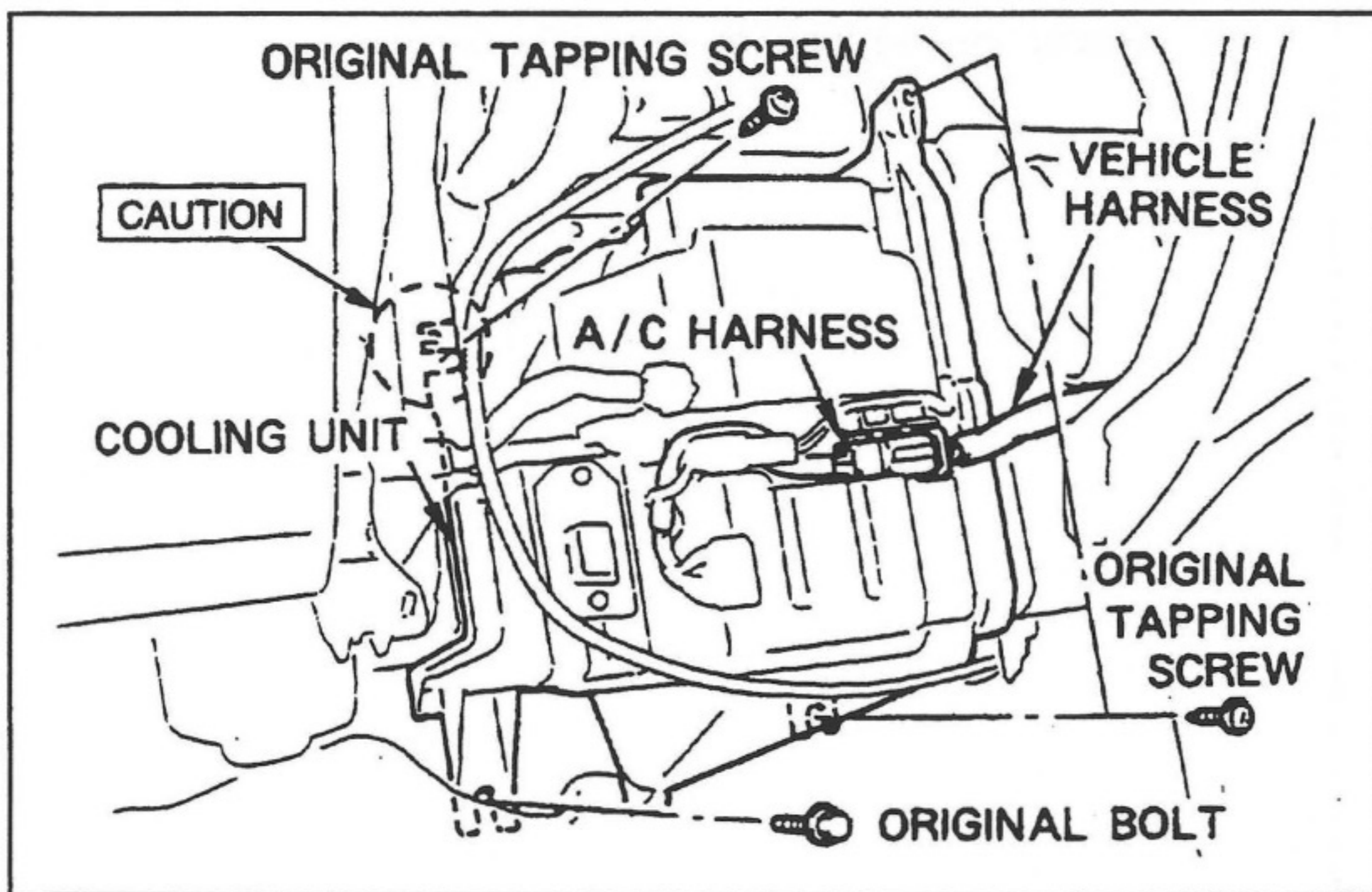

- (f) Install the cooling unit using three original tapping screws and the bolt.
- (g) Connect the vehicle harness to the A/C harness connector.

**CAUTION**

*Align the cut point of cooling unit with the edge of blower unit, when installing it.*

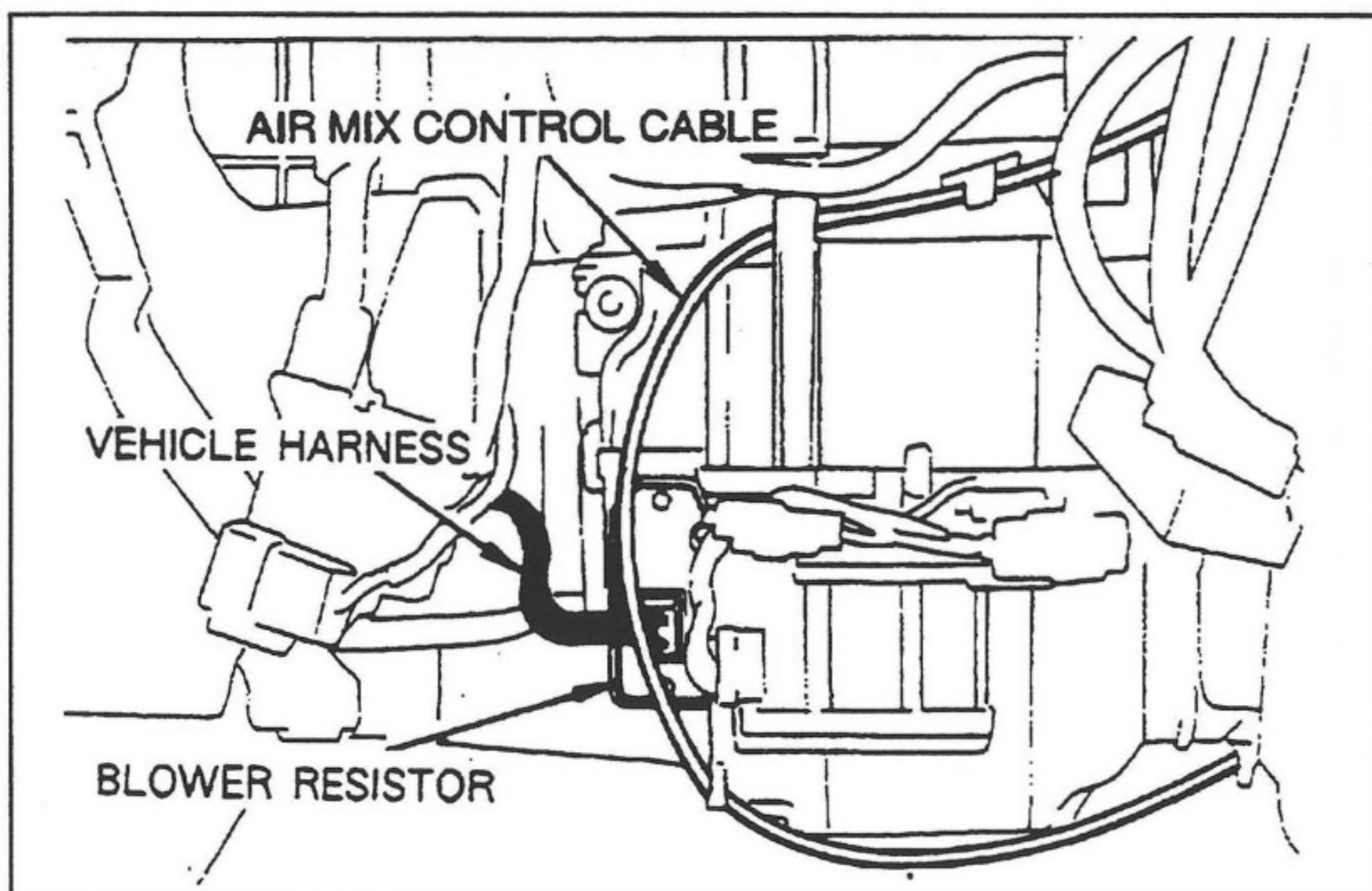

- (h) Connect the vehicle harness to the blower resistor.
- (i) Secure the air mix control cable to the cooling unit.

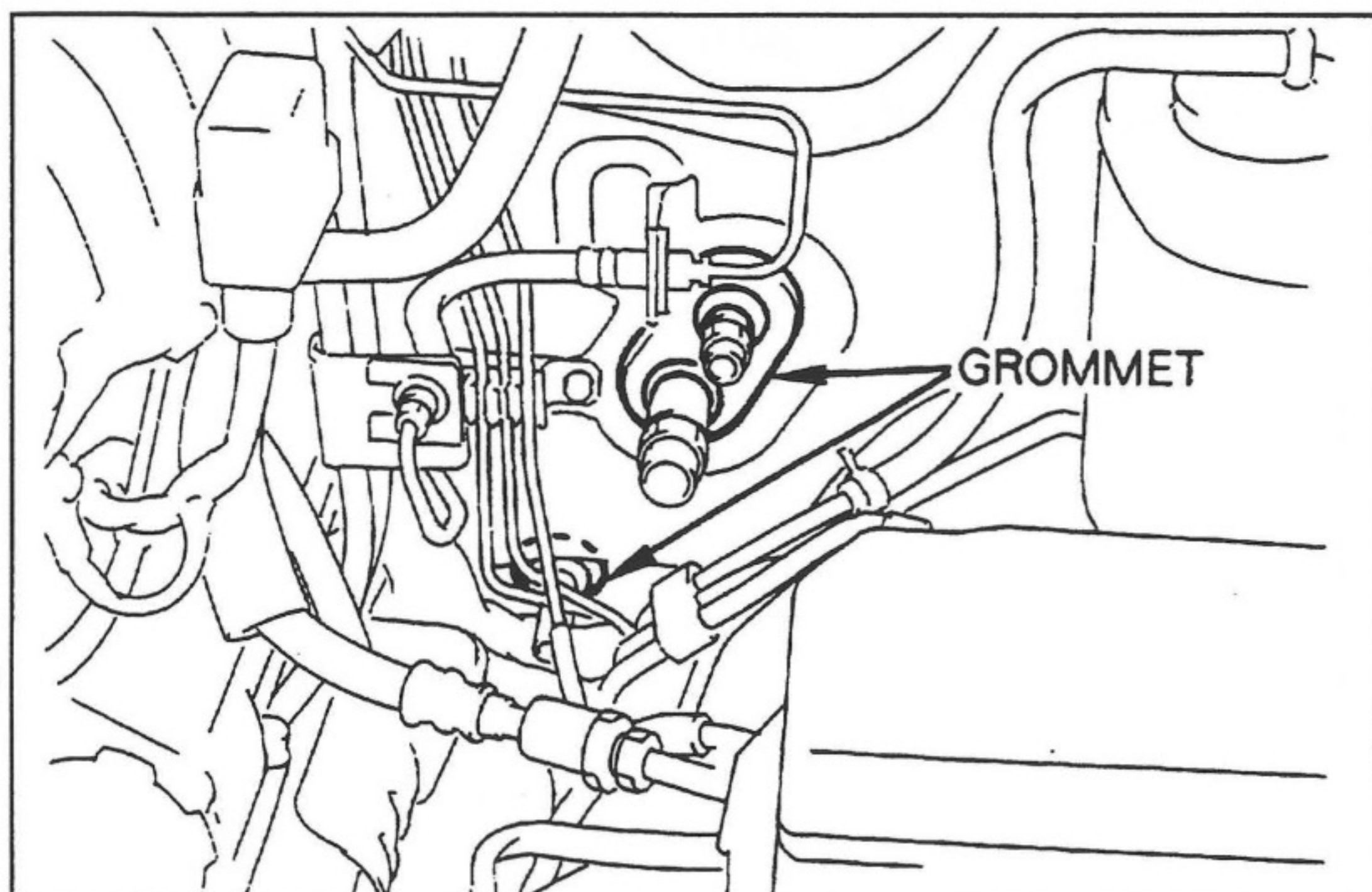

**(3) GROMMET**

- (a) Install the two grommets from the engine compartment side.

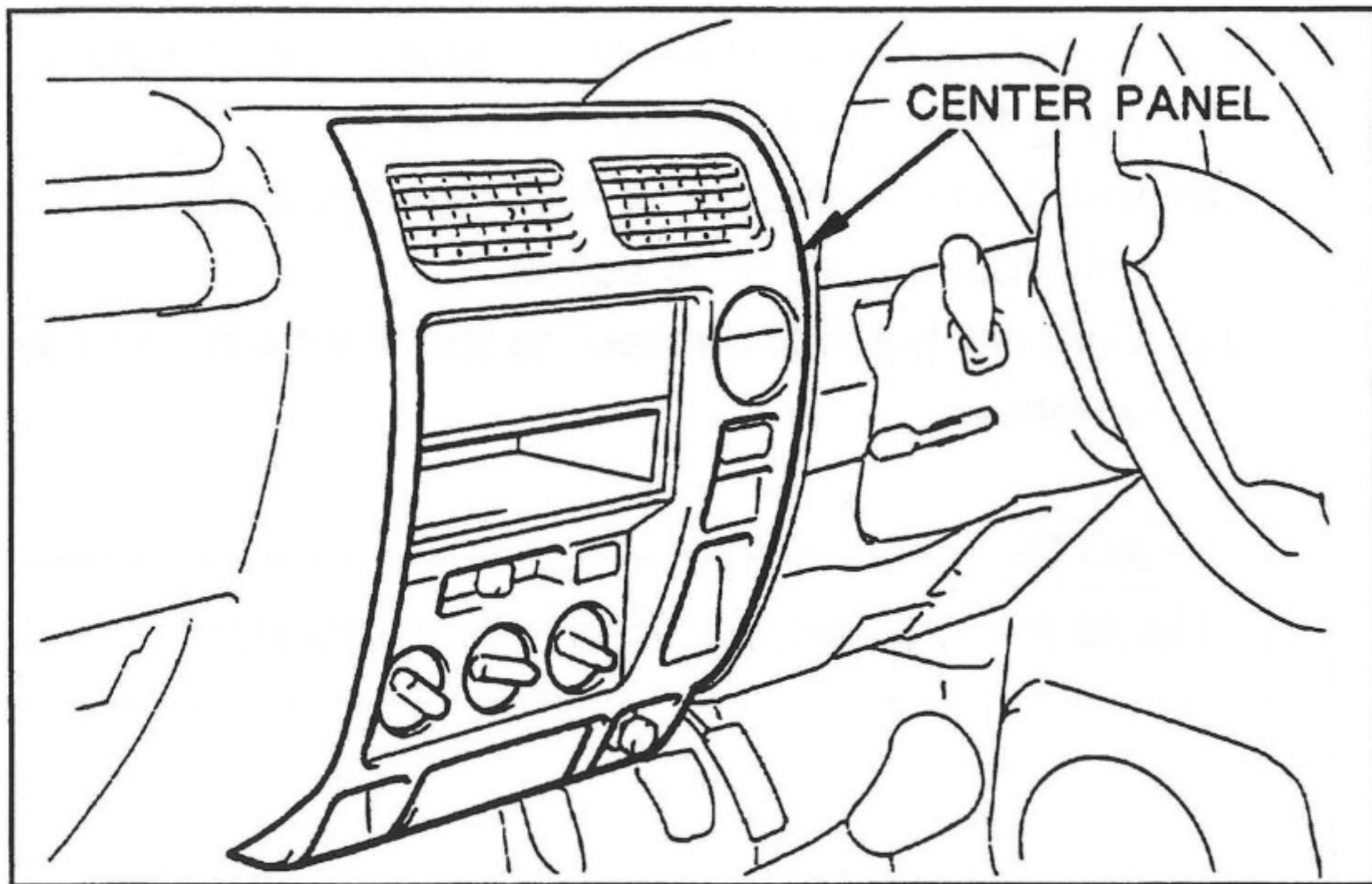

**(4) A/C SWITCH**

- (a) Remove the center panel.

**!CAUTION**

*When removing center panel, be careful not to cause any damage. Use SST 09070-20010.*

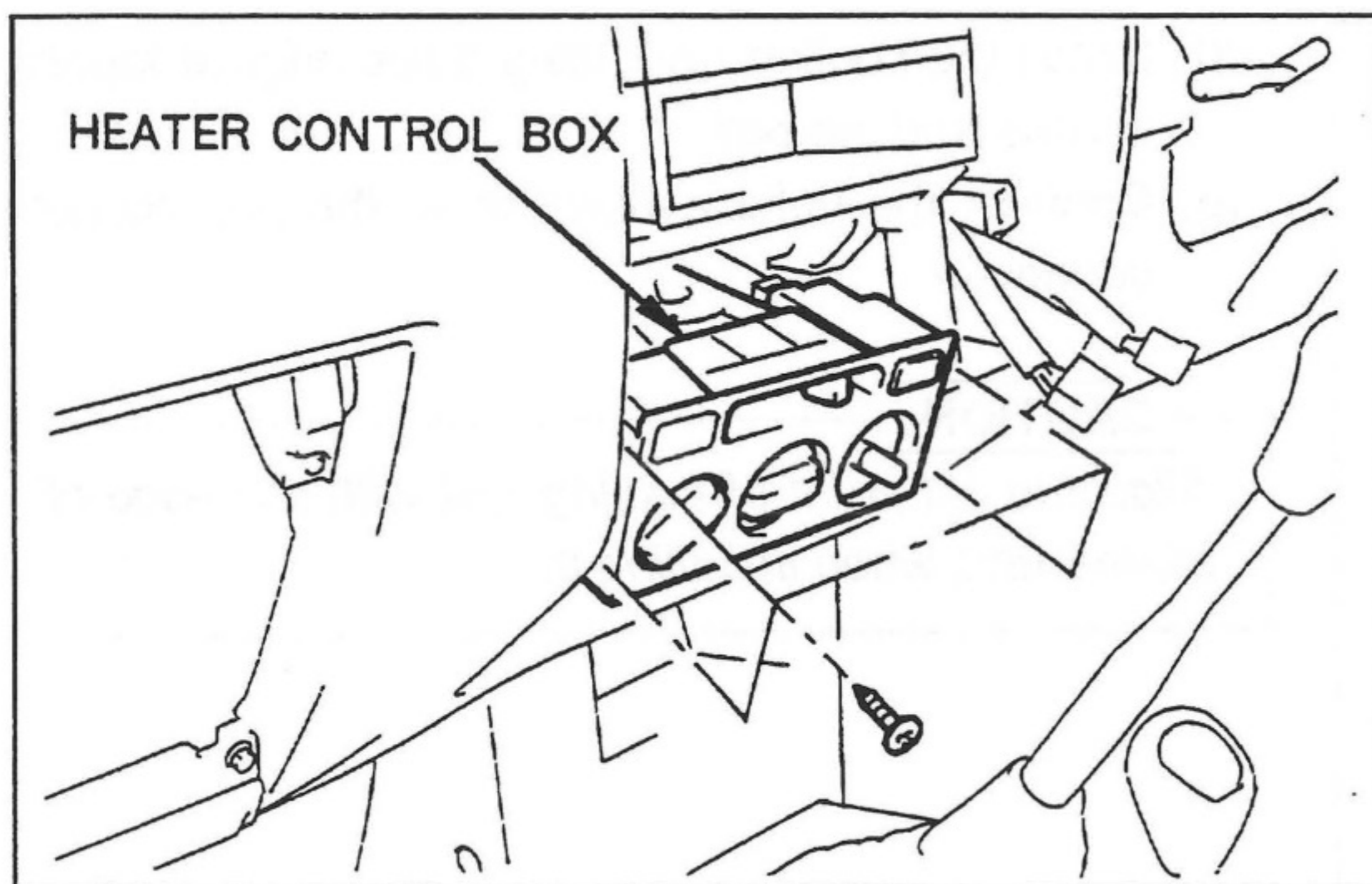

- (b) Remove the heater control box.

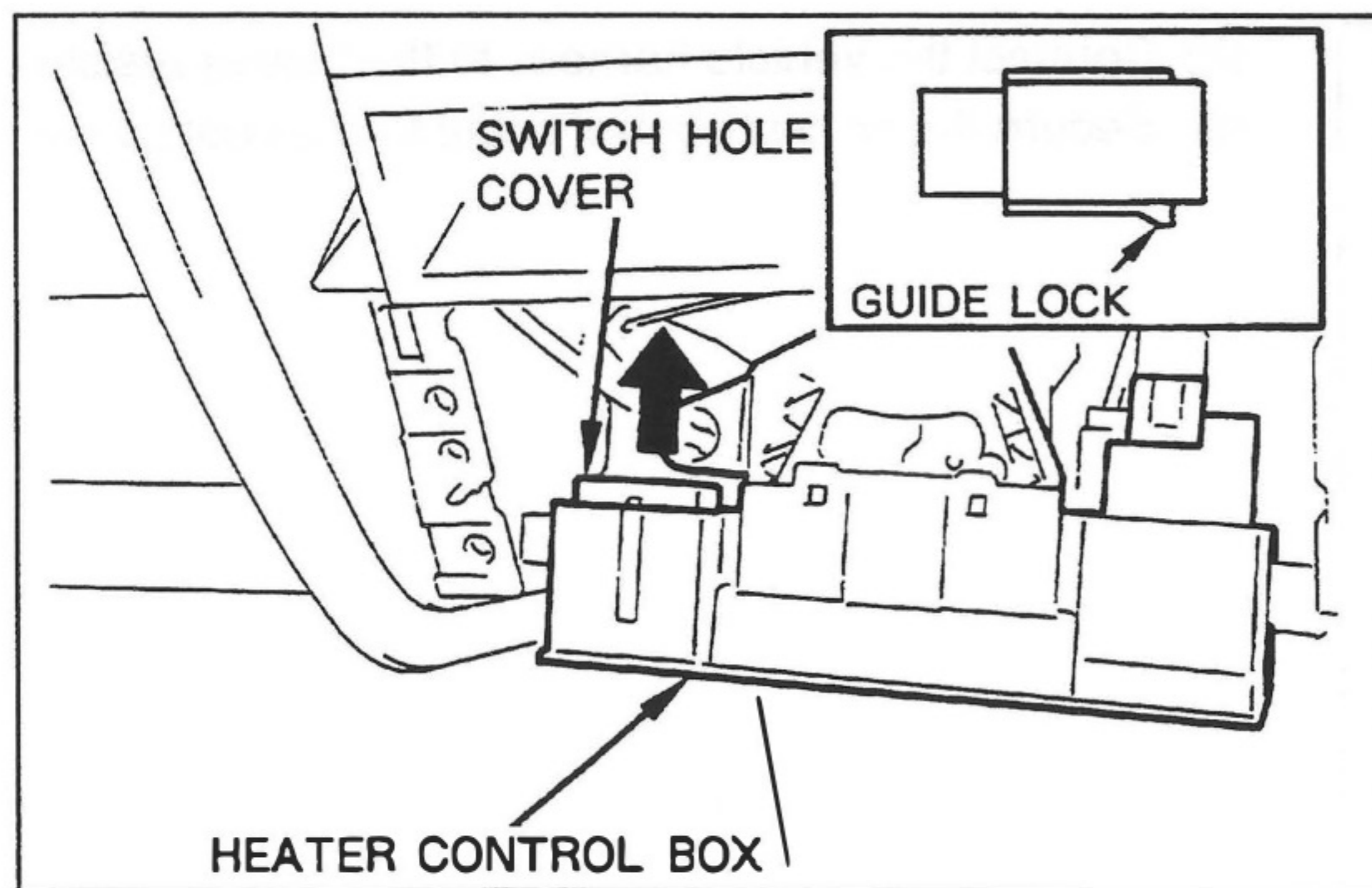

- (c) Remove and discard the switch hole cover.

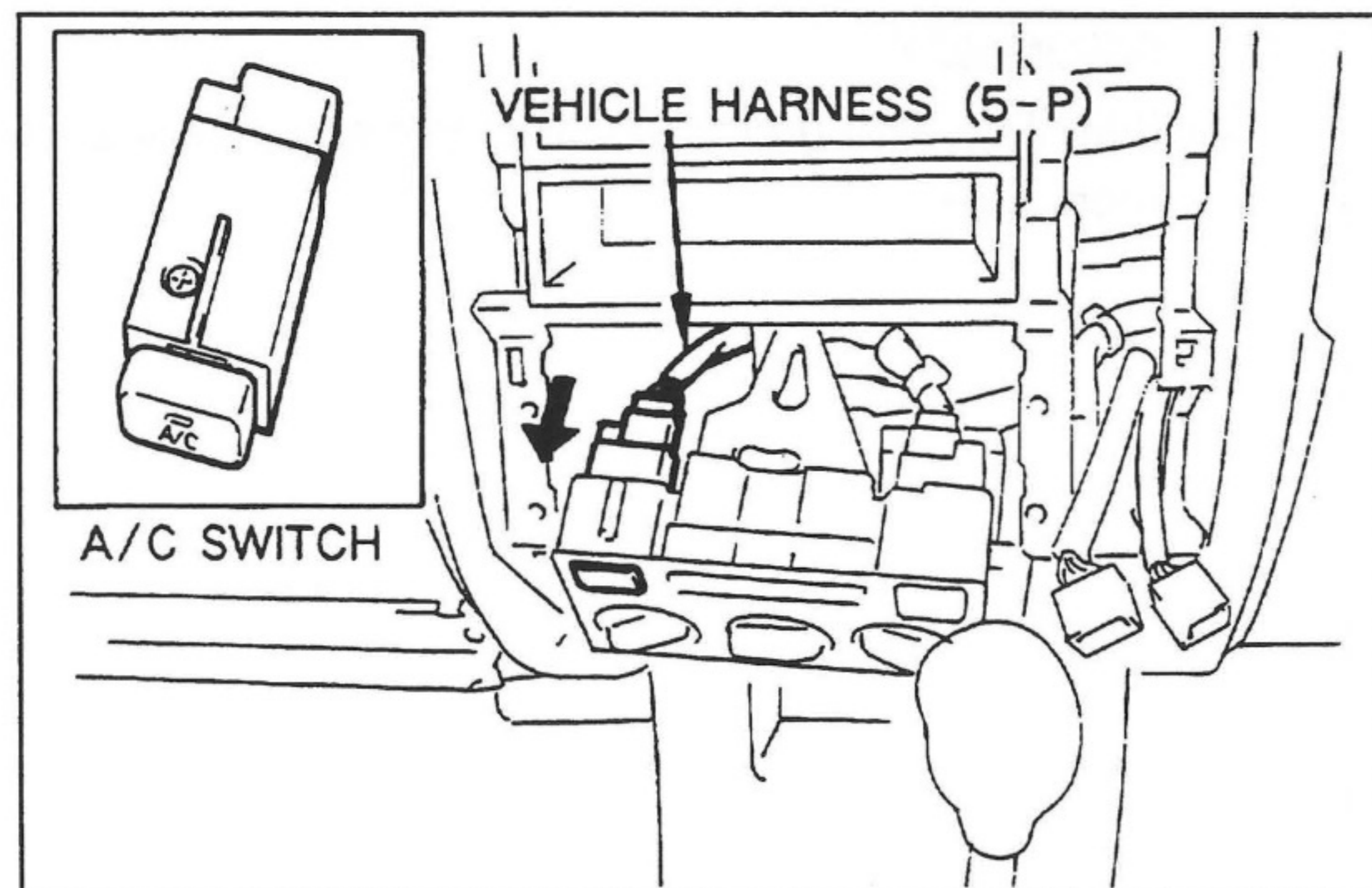

- (d) Insert the A/C switch behind the heater control box.  
(e) Connect the vehicle harness (5-P) to the A/C switch.

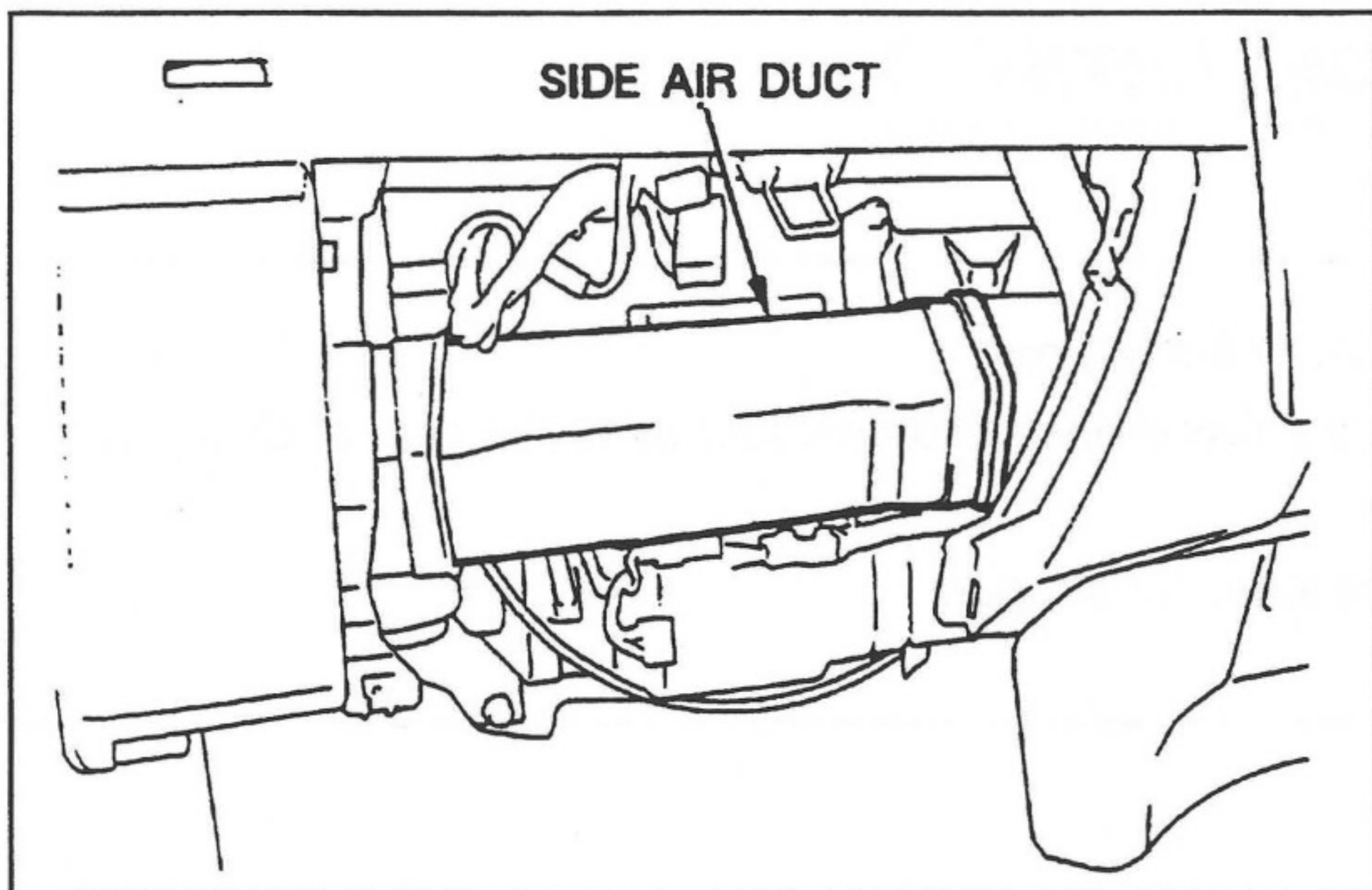

(f) Reinstall the side air duct.

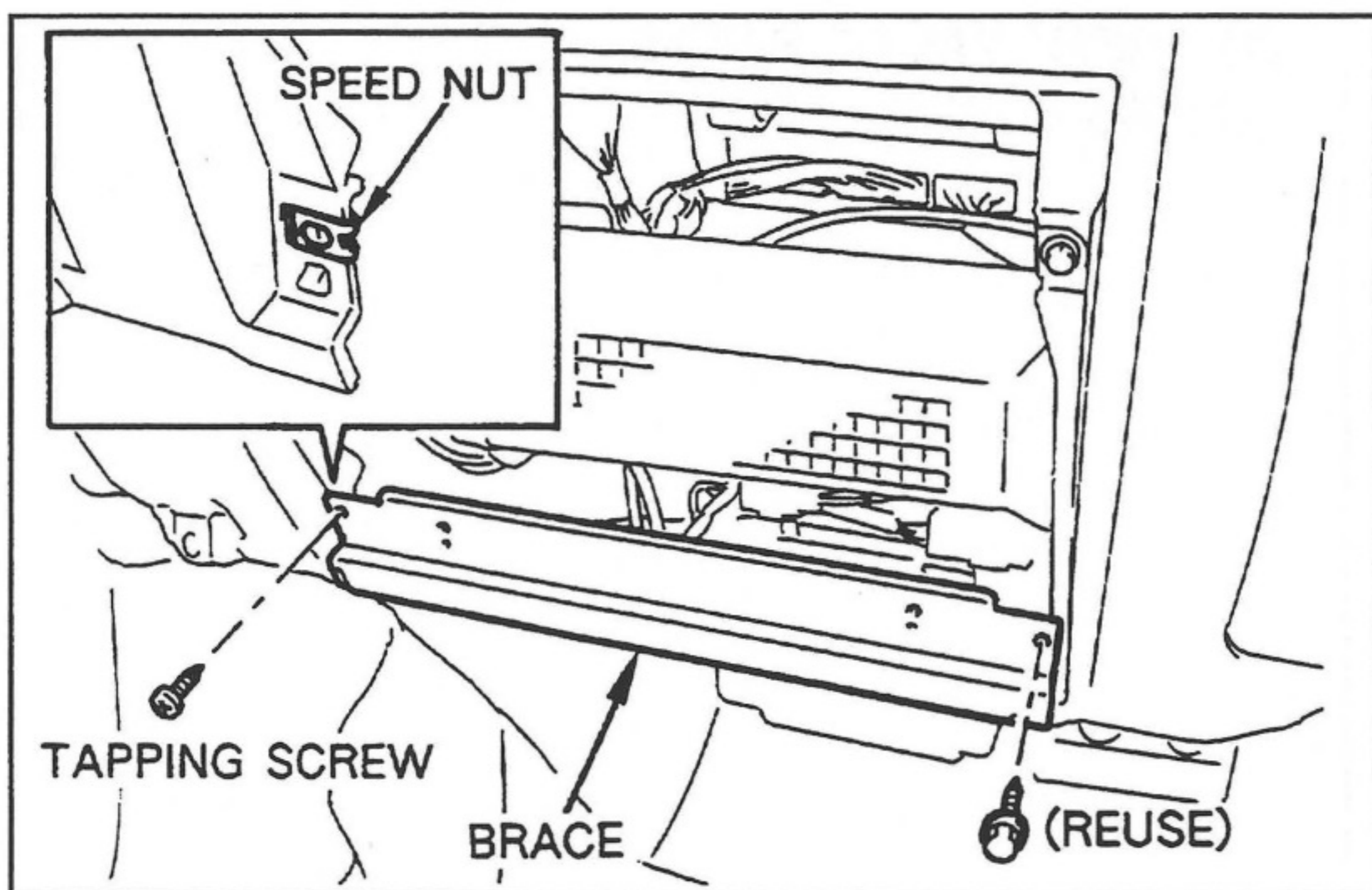

(g) Install the speed nut to the left side of instrument panel edge.

(h) Install the brace using tapping screw and the original tapping screw.

##### (5) REINSTALLATION OF PARTS

Reinstall the following temporarily removed parts.

## 2-2 INSTALLATION INSIDE ENGINE COMPARTMENT

### ! CAUTION

1. Before starting installation, remove the negative cable from the battery.
2. Before making any hoses and tubes connections, apply a few drops of compressor oil to the seat of O-ring and coupling nuts.
3. When tightening and loosening the fittings, use two wrenches for support.
4. Ensure fender covers are in position.

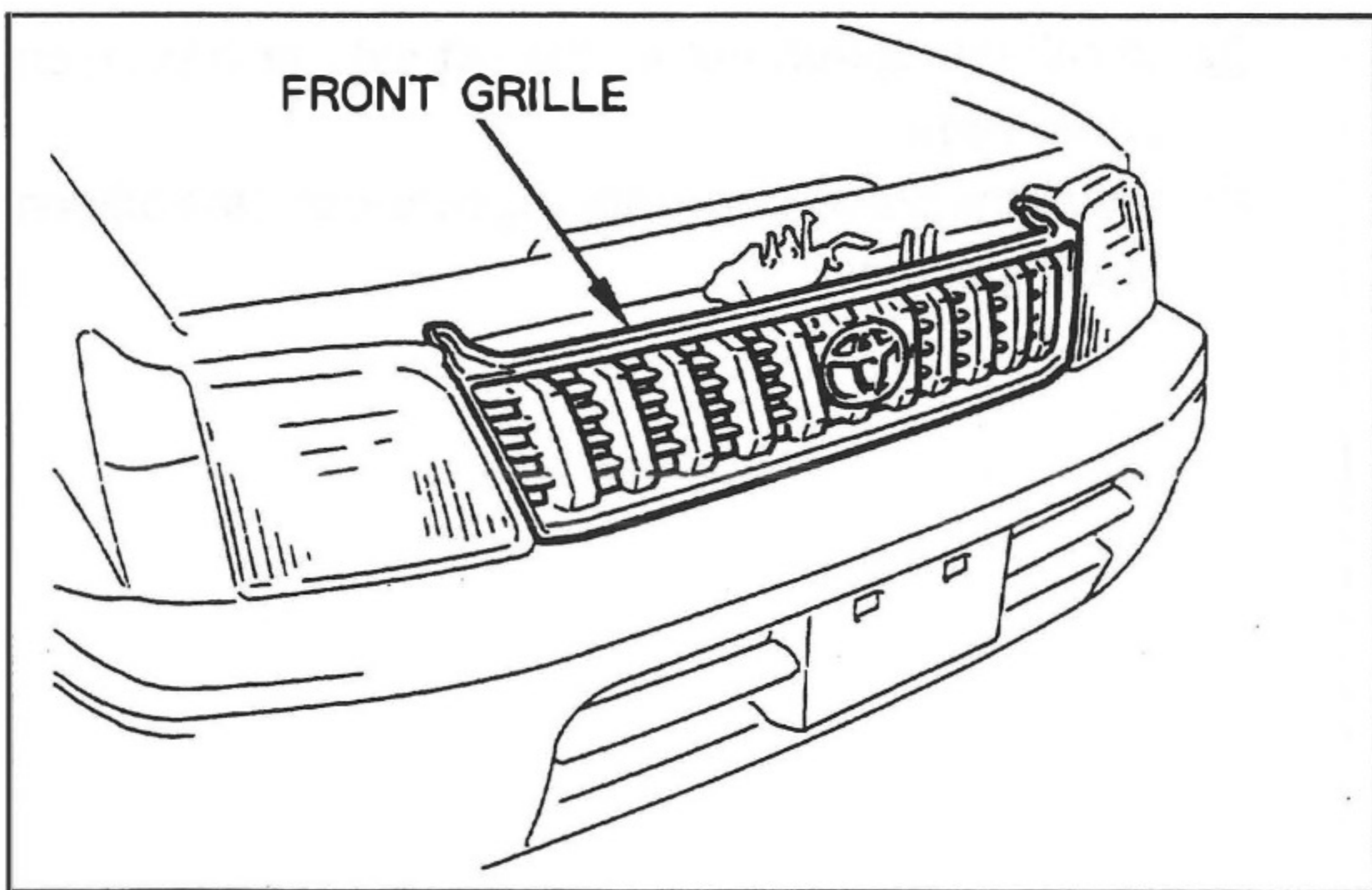

### (1) REMOVAL OF PARTS

(a) Front grille

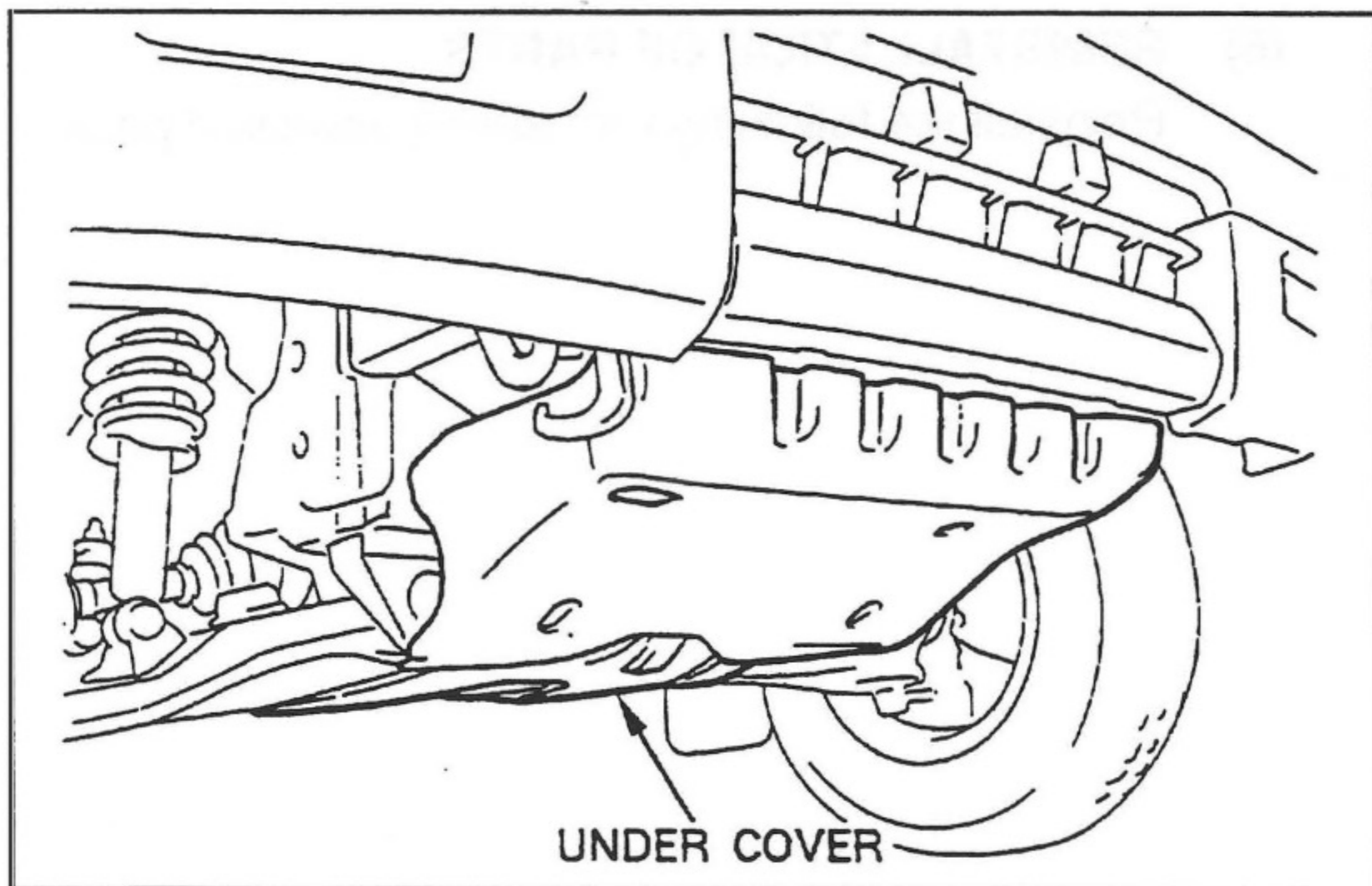

(b) Under cover

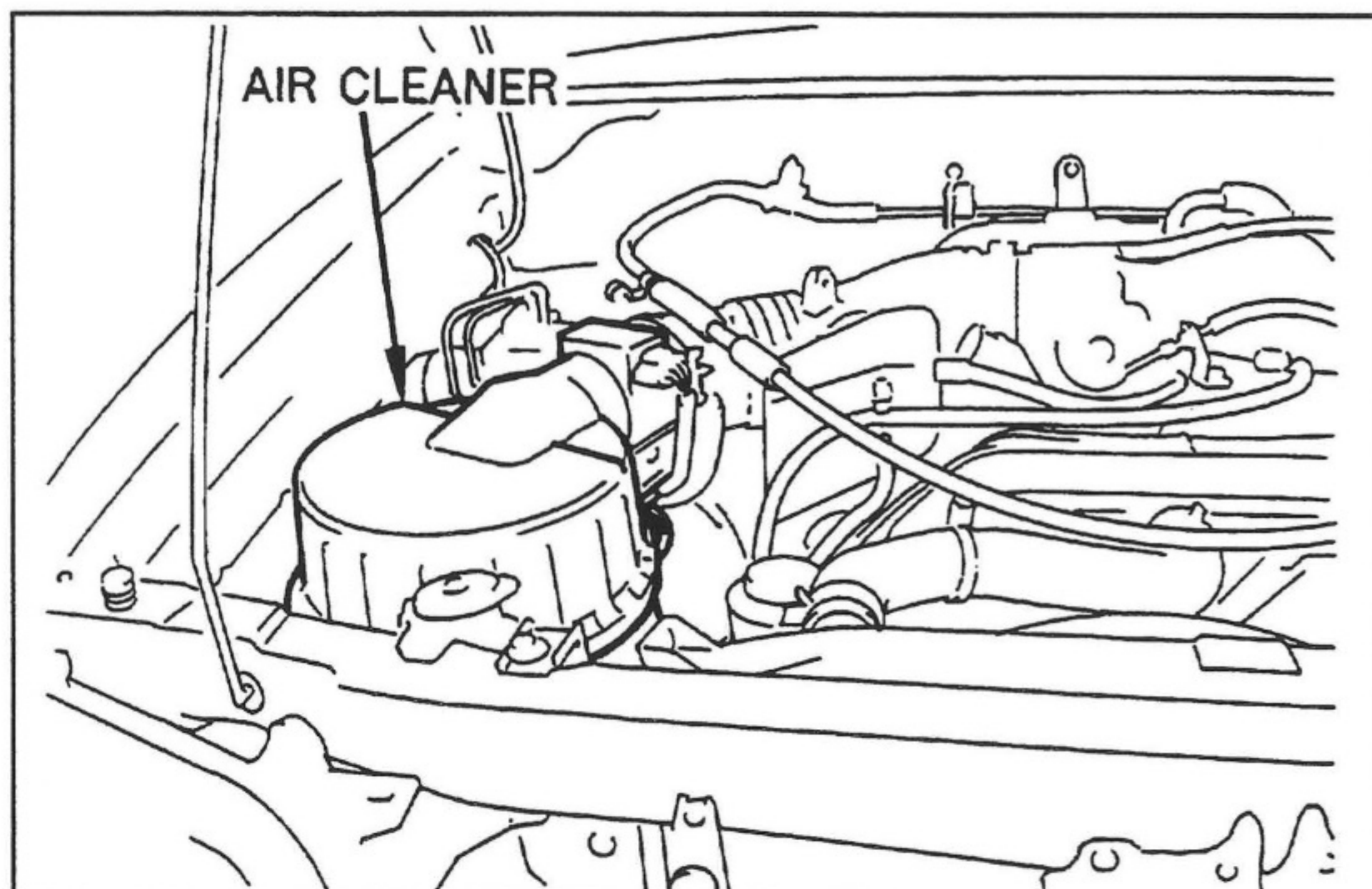

(c) Air cleaner

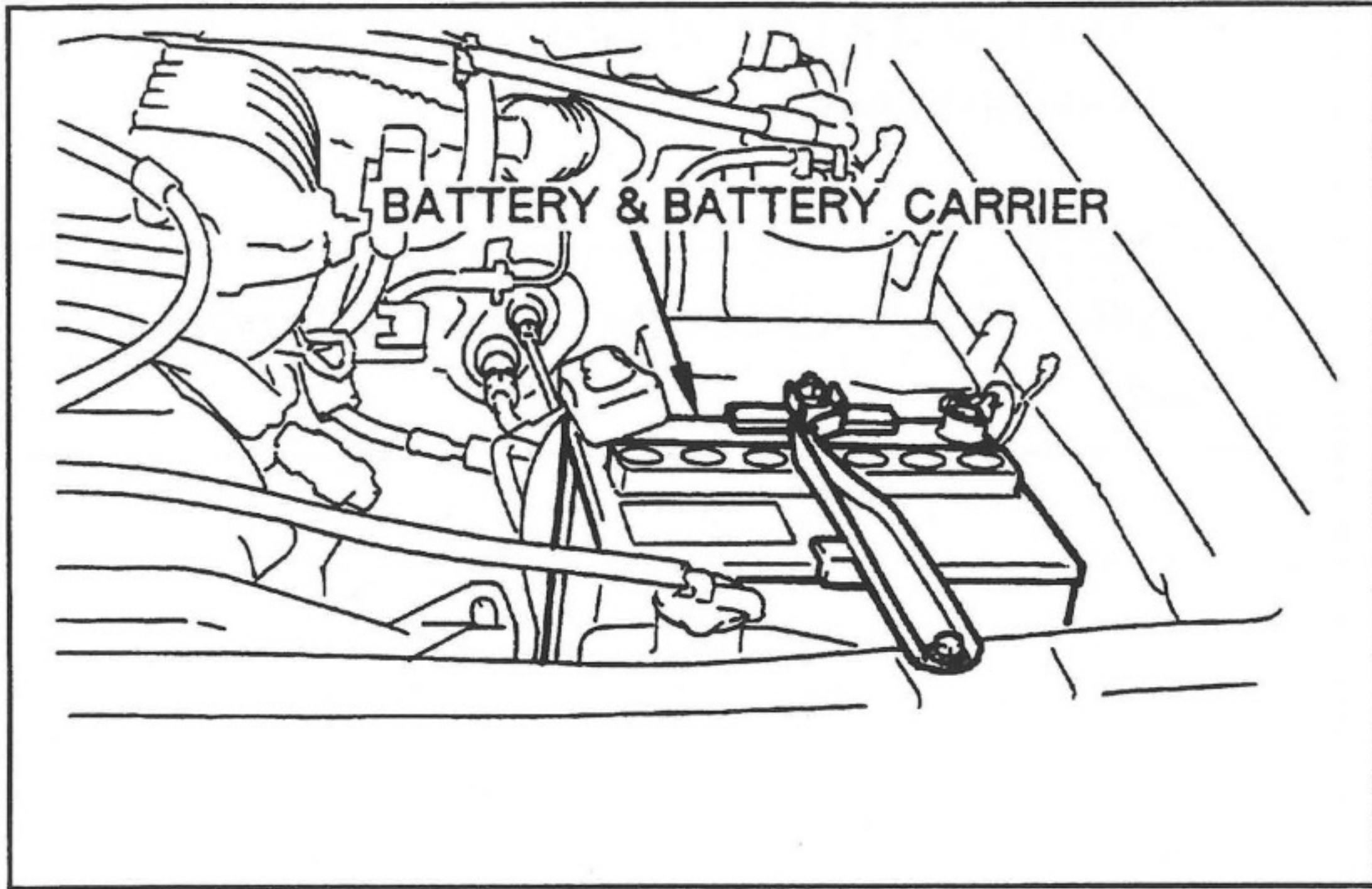

(d) Battery and Battery carrier

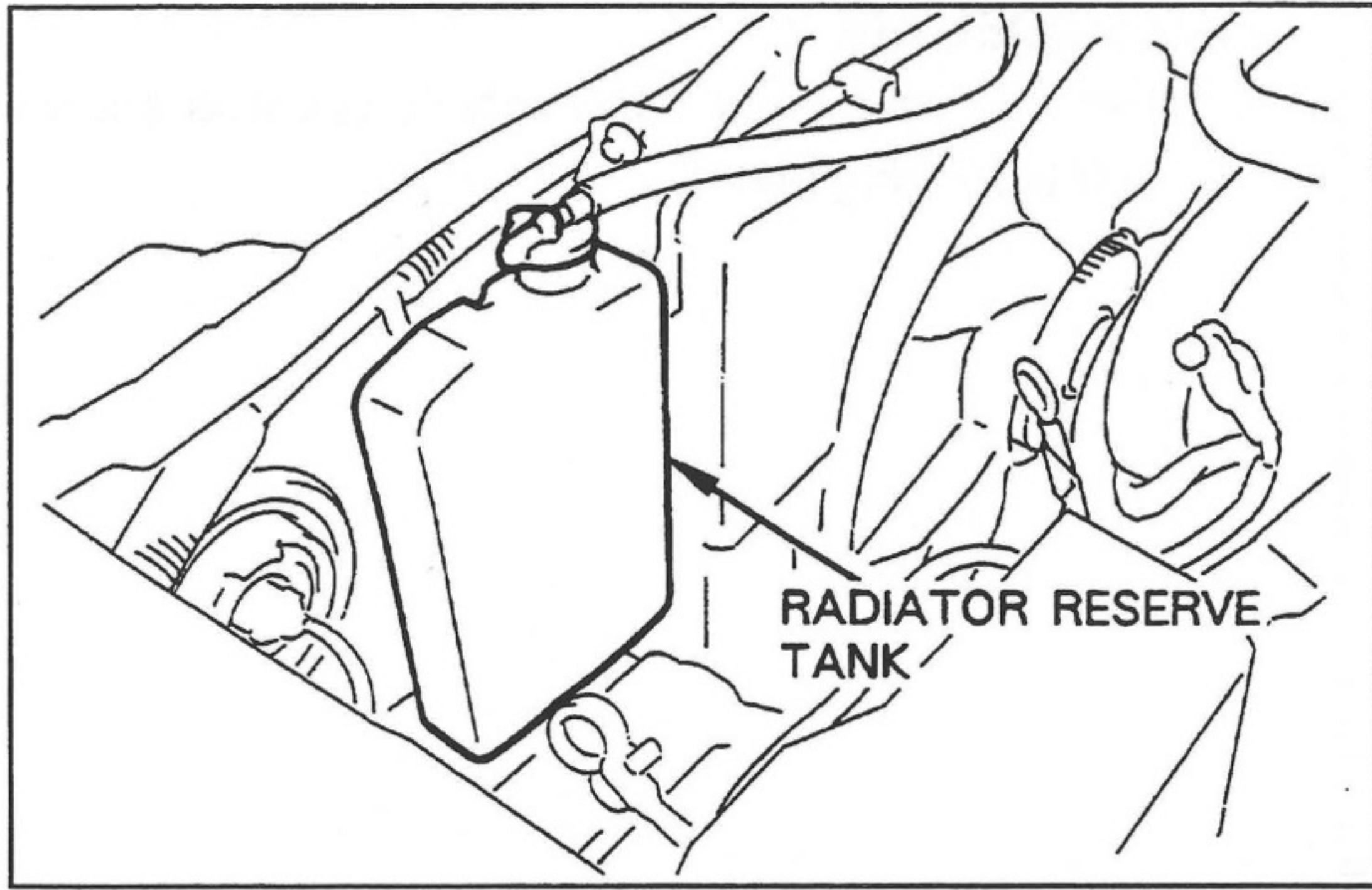

(e) Radiator reserve tank

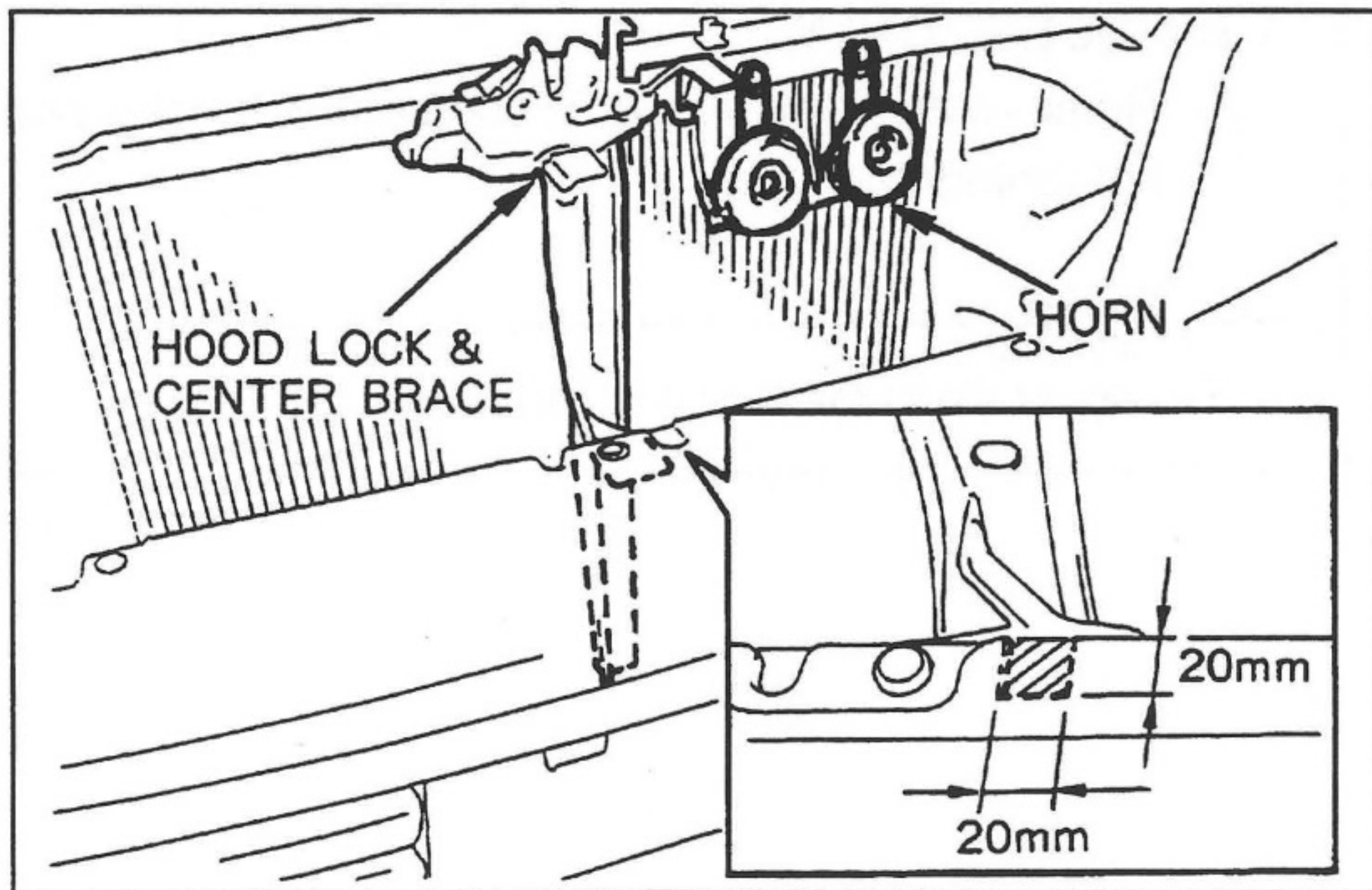

(f) Hood lock and Center brace

**NOTE**  
*Cut out the bumper at 20mm x 20mm before removing the center brace.*

(g) Horns

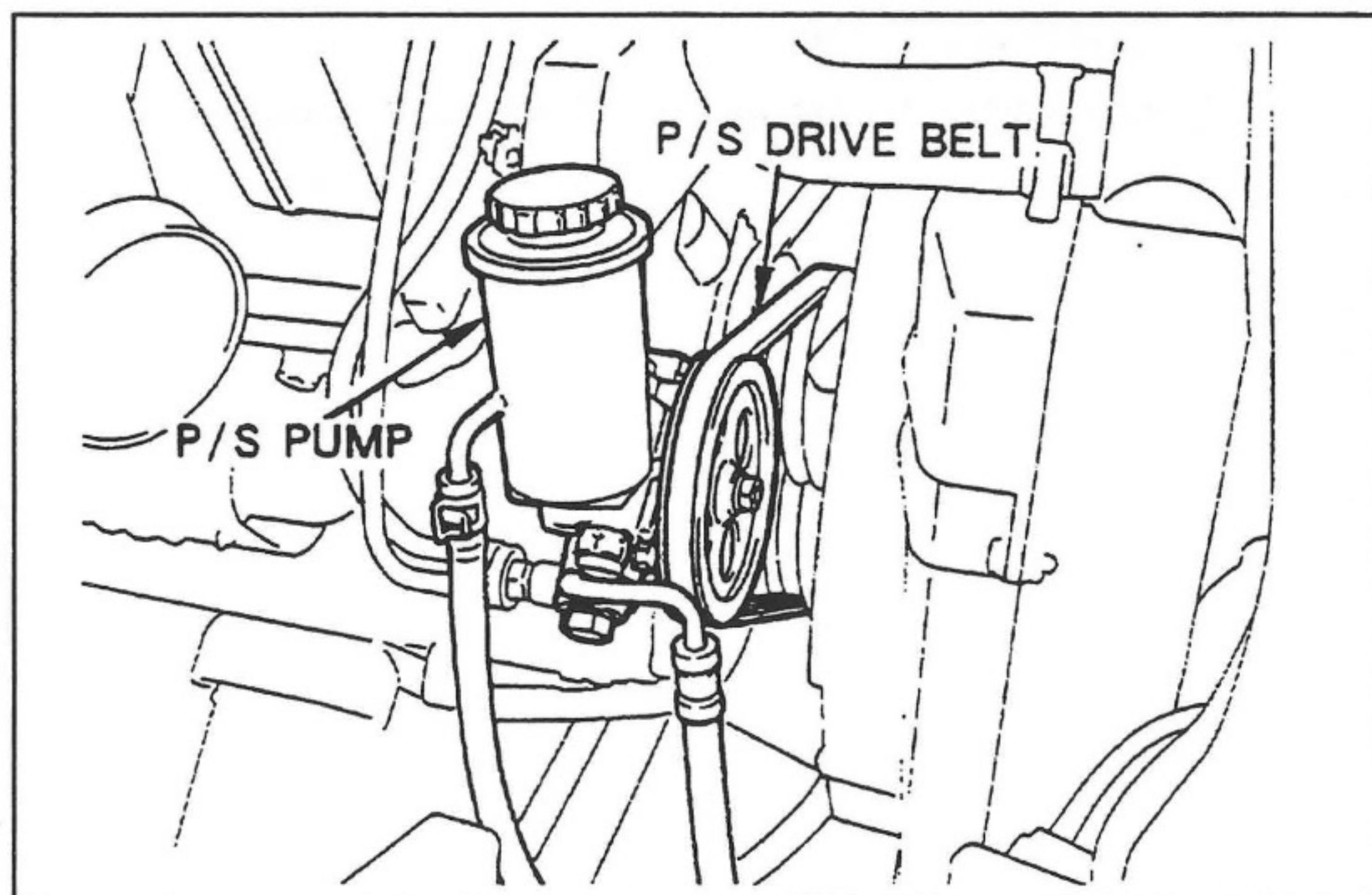

(h) P/S drive belt and P/S pump

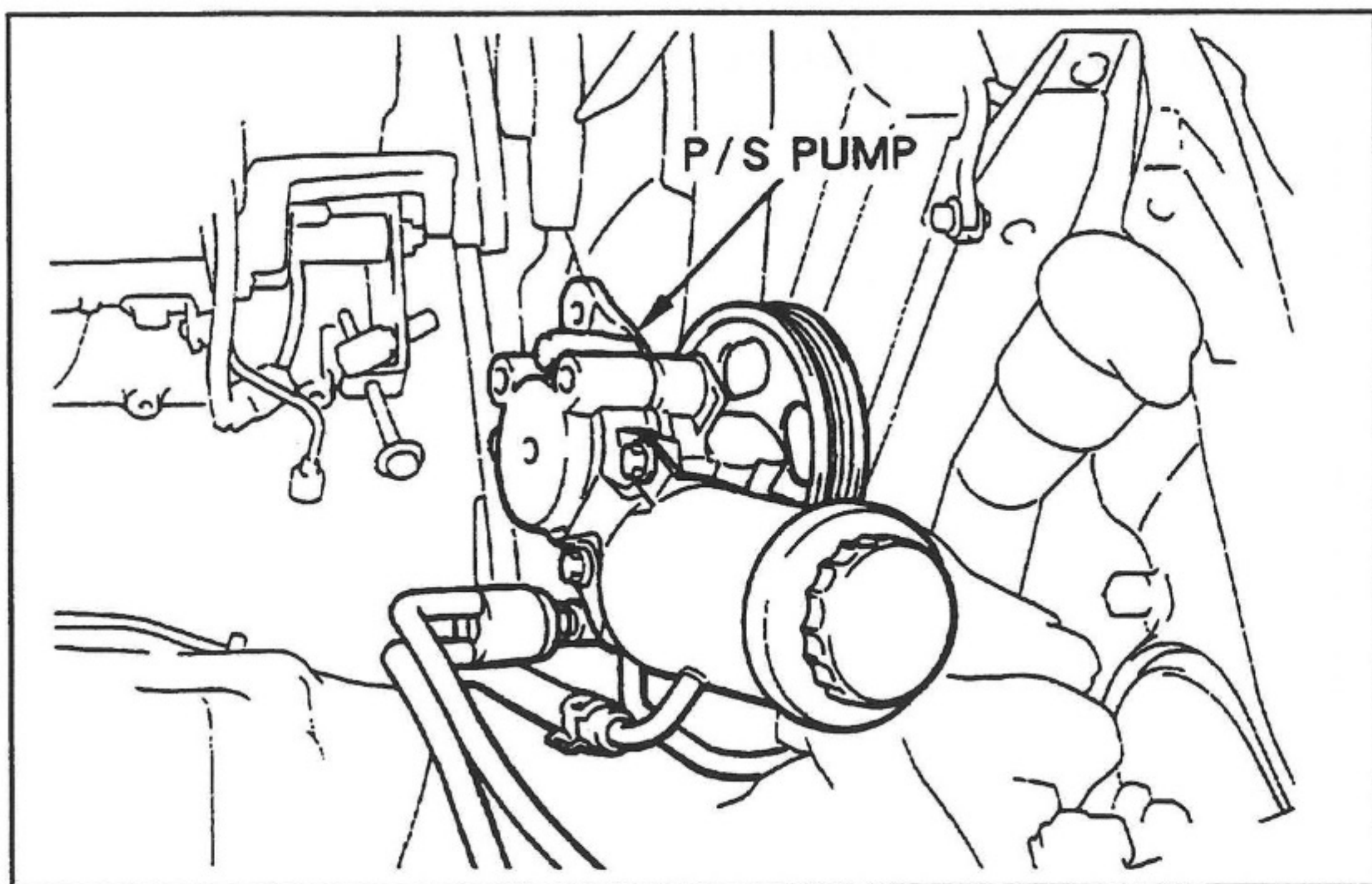

- (i) Put the P/S pump onto the fender well to make the installation easy.

**NOTE**

*Lay the fender covers on the fender wall to protect the body.*

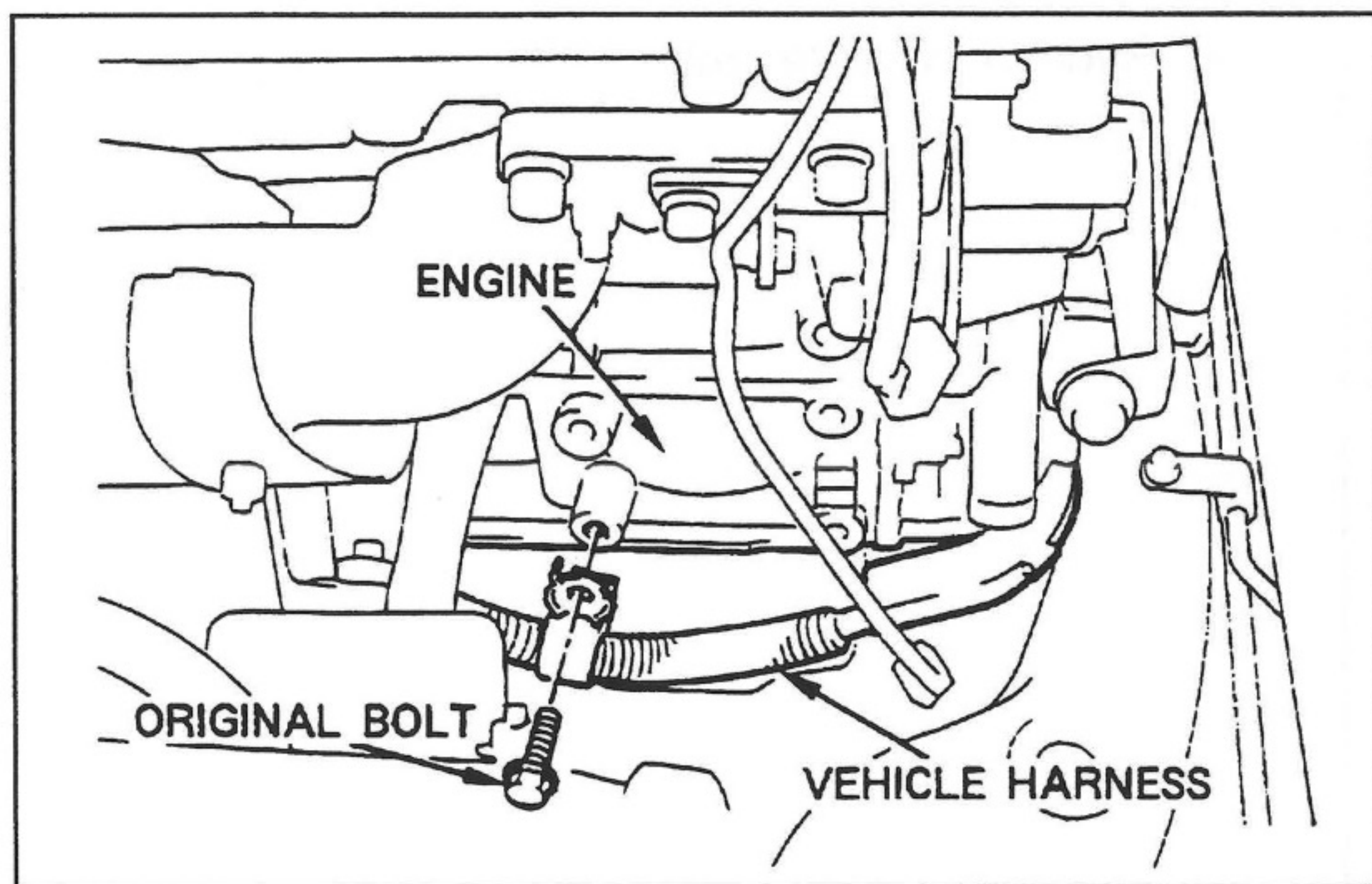

• **M/T MODEL ONLY**

- (j) Remove and discard the vehicle harness bracket and tightening bolt.

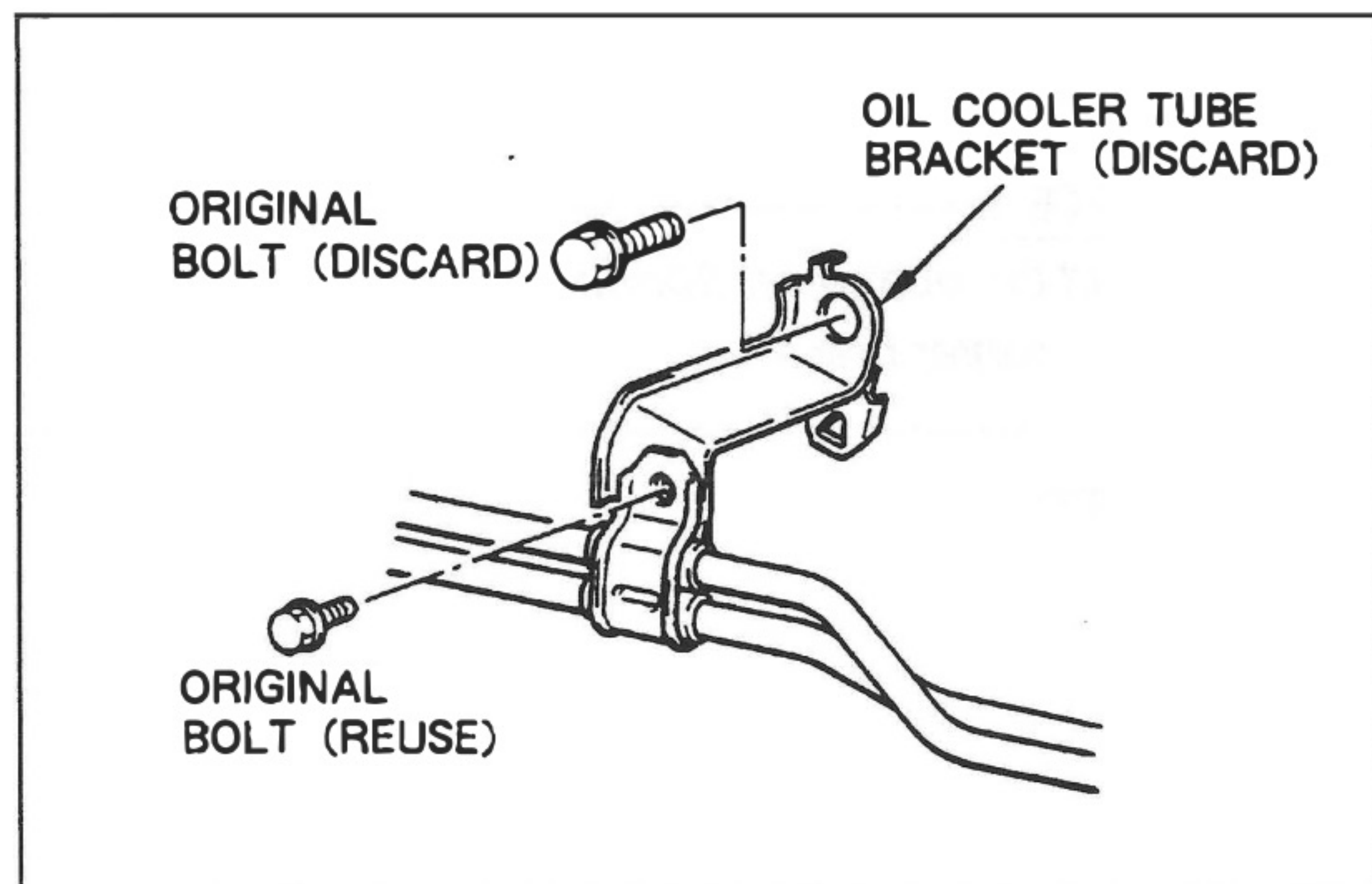

• **A/T MODEL ONLY**

- (k) Remove and discard the oil cooler tube bracket and tightening bolt.

**NOTE**

*Do not discard the one original bolt.*

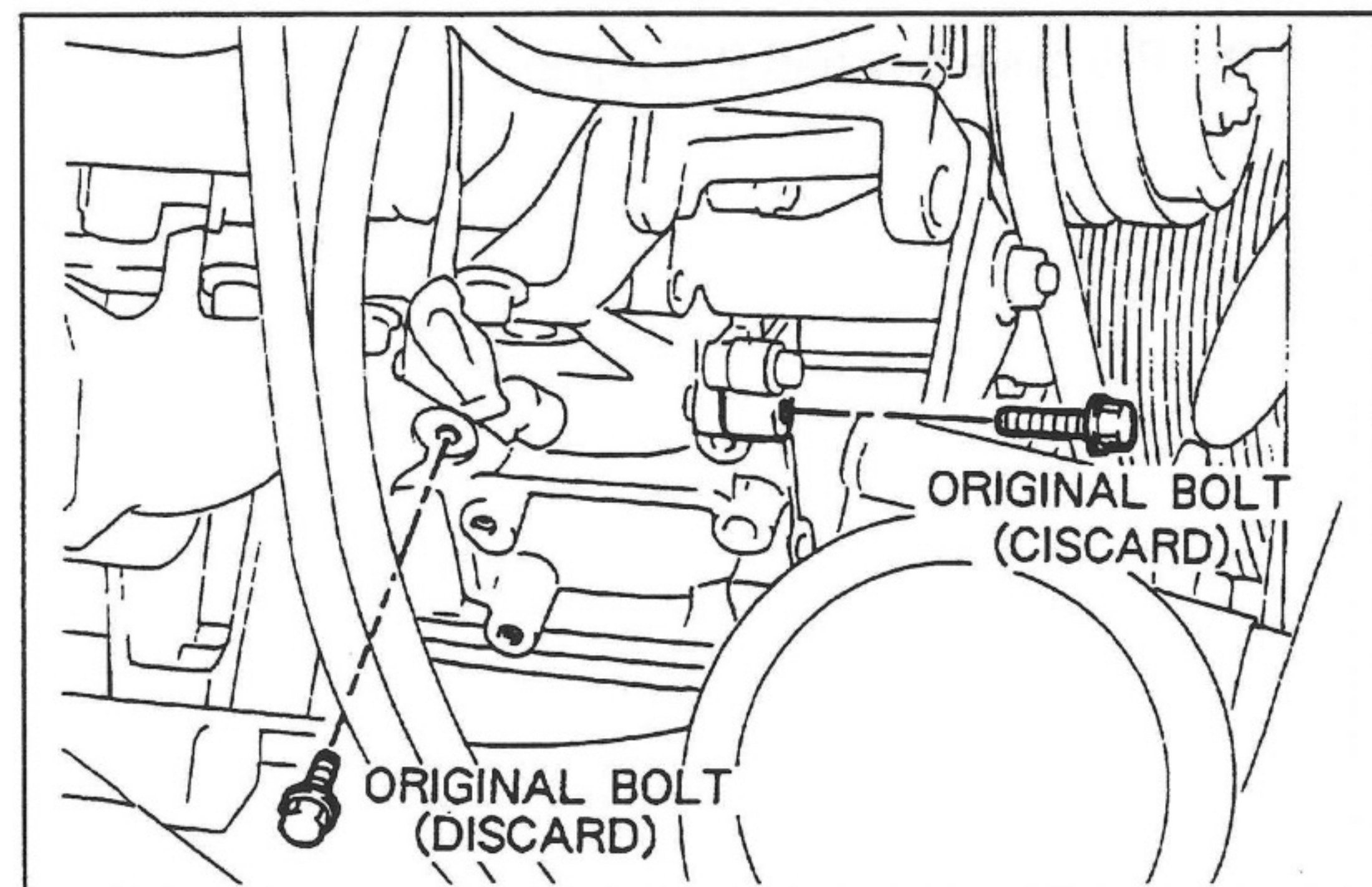

(2) **COMPRESSOR**

- (a) Remove and discard the two original bolts.

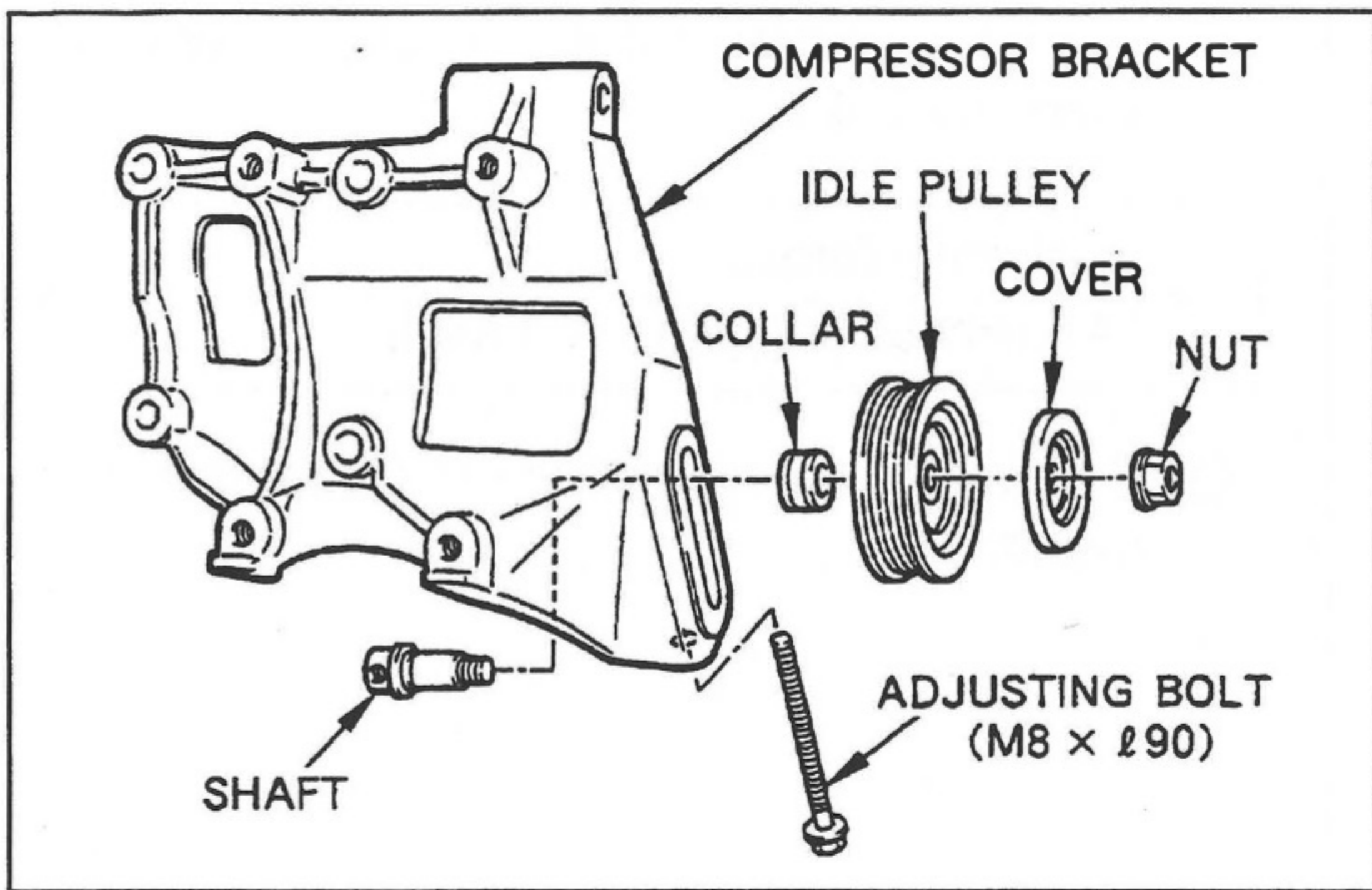

(b) Assemble the idle pulley assy to the compressor bracket.

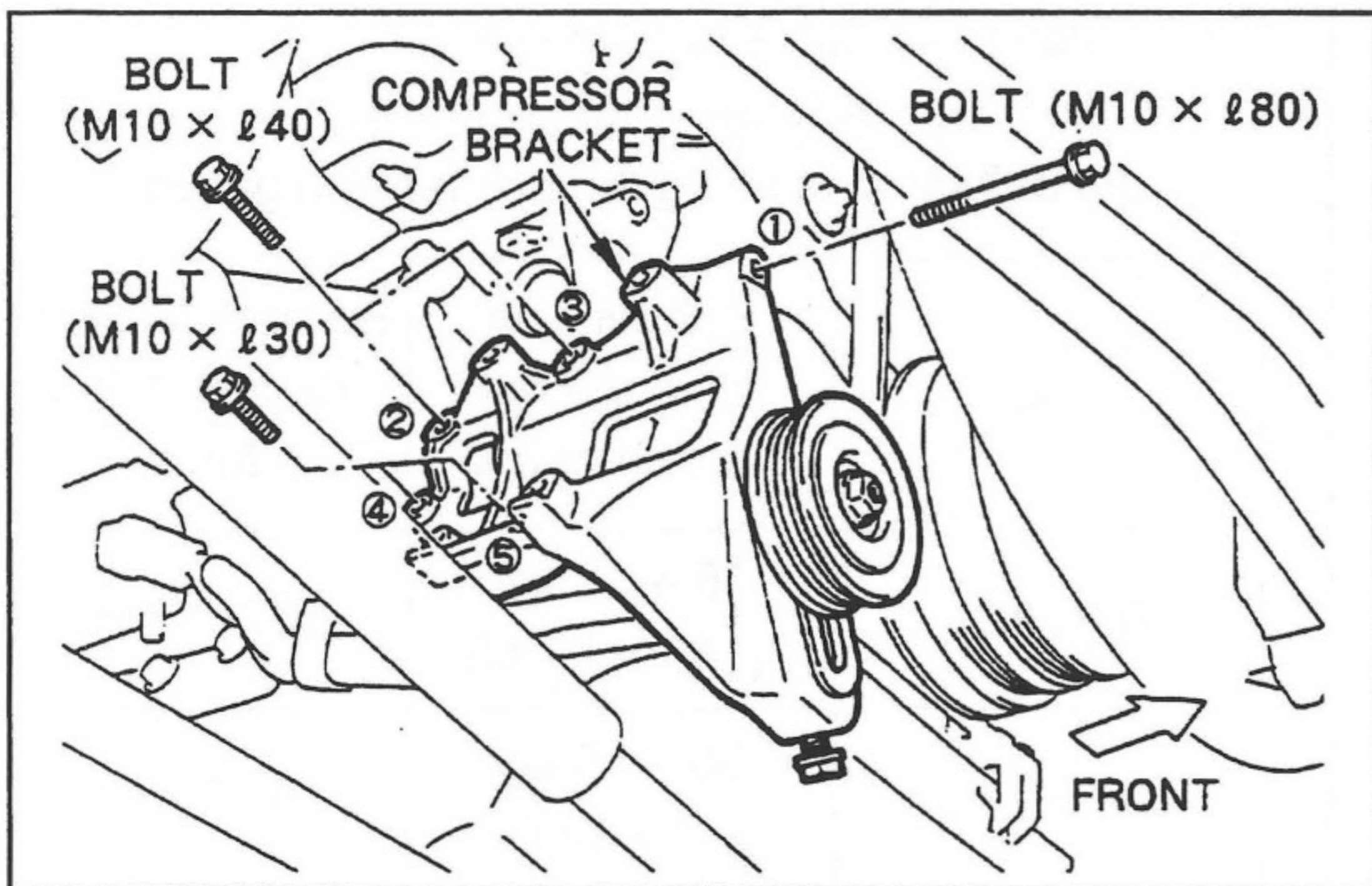

(c) Install the compressor bracket to the engine block using five bolts.

Tightening Order : ① → ② → ③ → ④ → ⑤

Tightening Torque

46.6 N•m (475 kgf•cm, 34.2 ft•lbf)

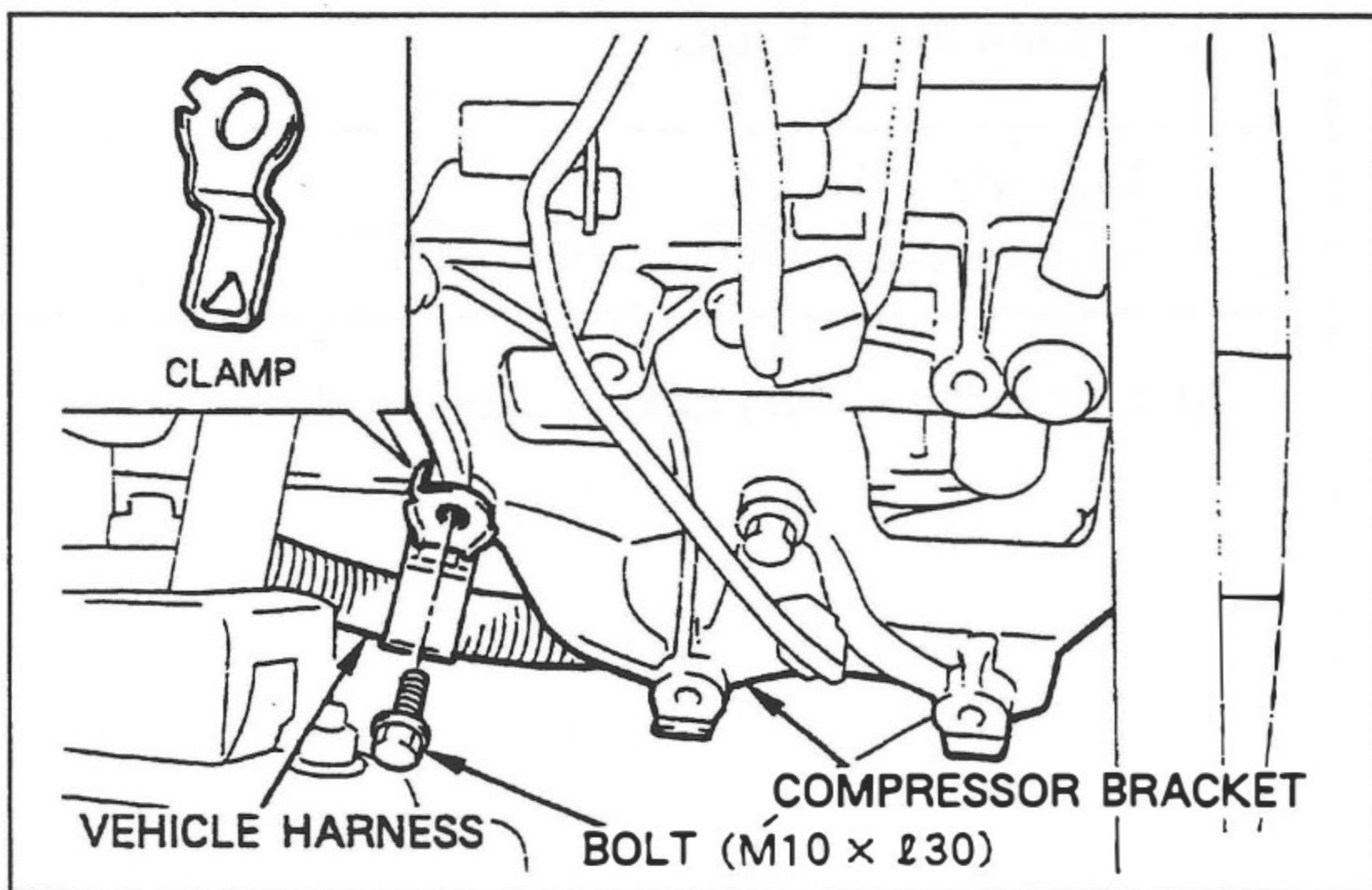

• **M/T MODEL ONLY**

(d) Tighten the harness bracket together with compressor bracket using ④ bolt.

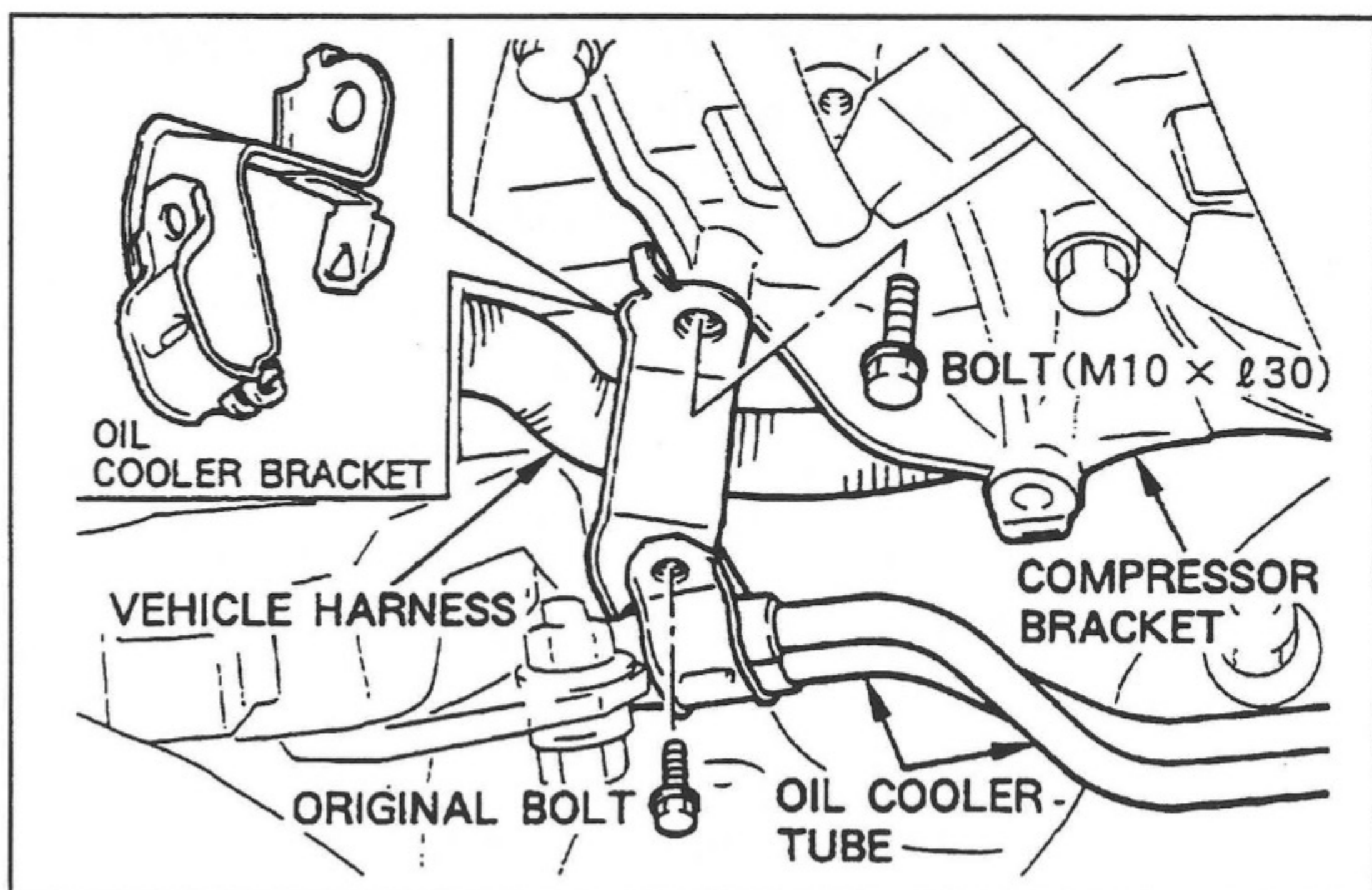

• **A/T MODEL ONLY**

(e) Tighten the oil cooler tube bracket together with compressor bracket using ④ bolt.

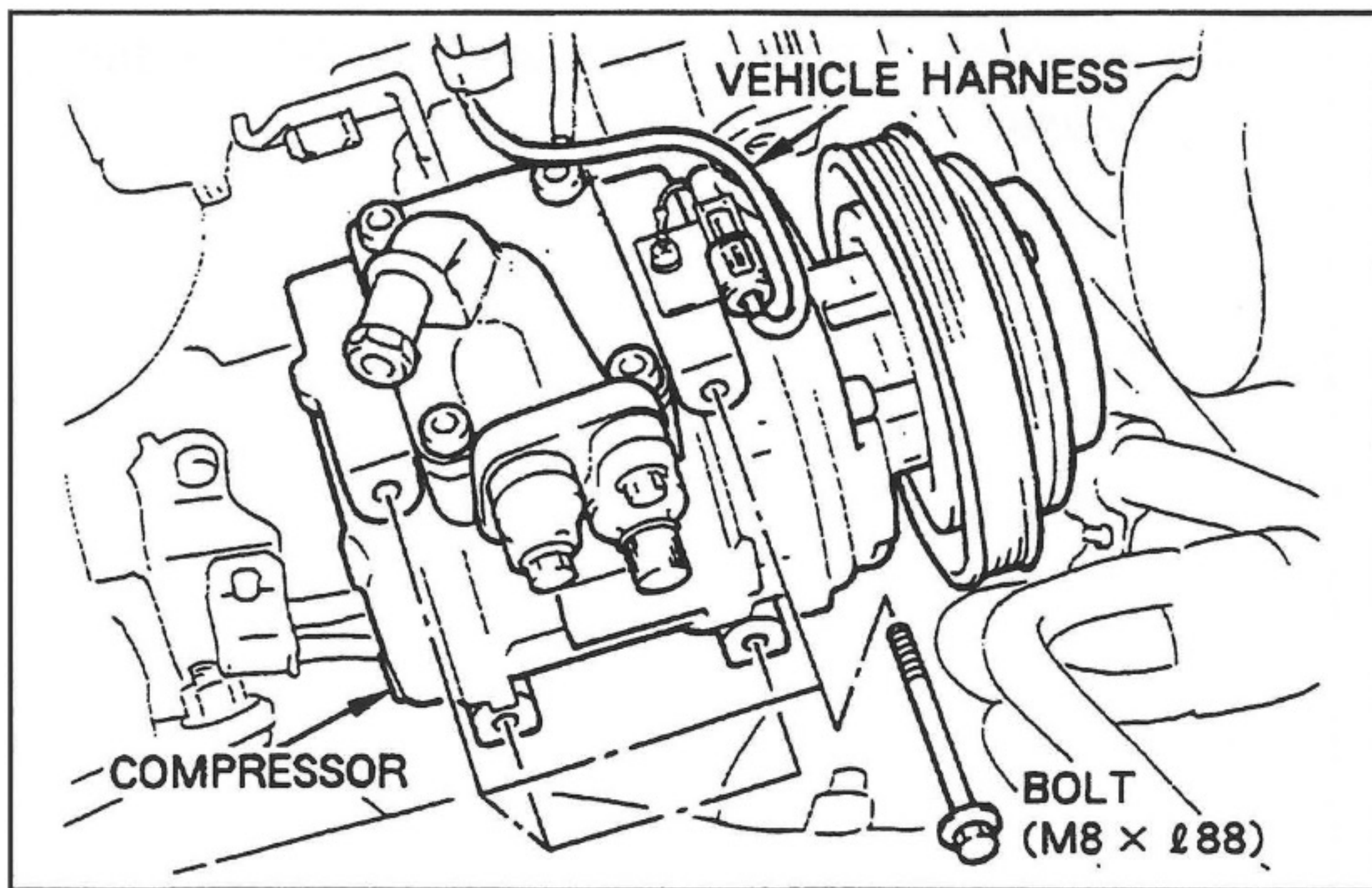

- (f) Install the compressor to the compressor bracket using four bolts.

Tightening Torque
24.5 N•m (250 kgf•cm, 18.1 ft•lbf)

- (g) Connect the vehicle harness to the mg.clutch connector.

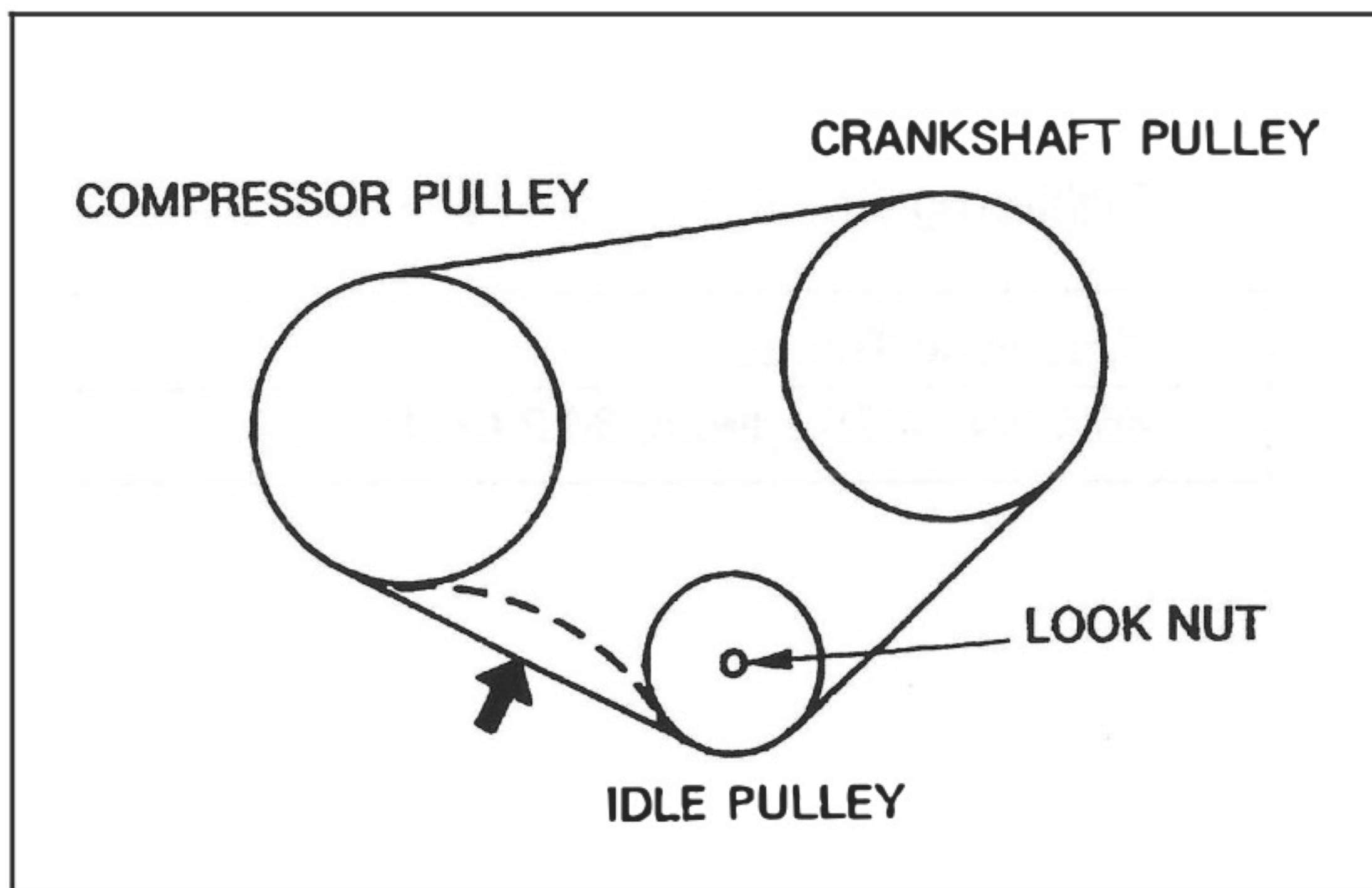

- (h) Install the compressor drive belt.  
 (i) Adjust the belt tension using the adjusting bolt, check the belt tension using the belt tension gauge.

	Belt tension using the belt tension gauge	Belt deflection at 10 kgf (22 lbf) force
New belt	65 + 12 kgf (143 + 26 lbf)	3.5 - 5 mm
Used belt	30 + 10 kgf (66 + 22 lbf)	5 - 7 mm

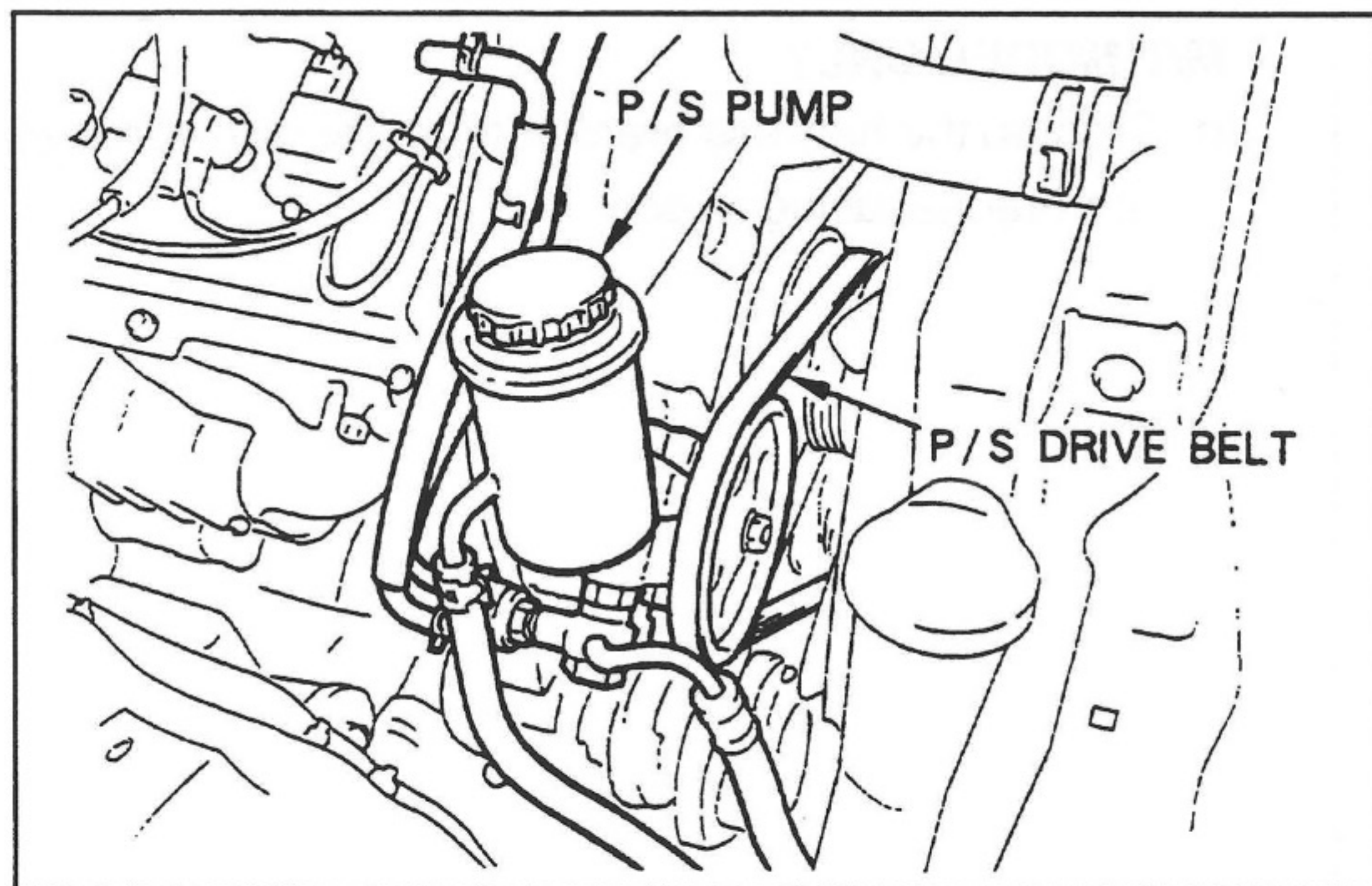

- (j) Tighten the lock nut.

Tightening Torque
39.2 N•m (400 kgf•cm, 28.8 ft•lbf)

- (k) Reinstall the P/S pump and drive belt.

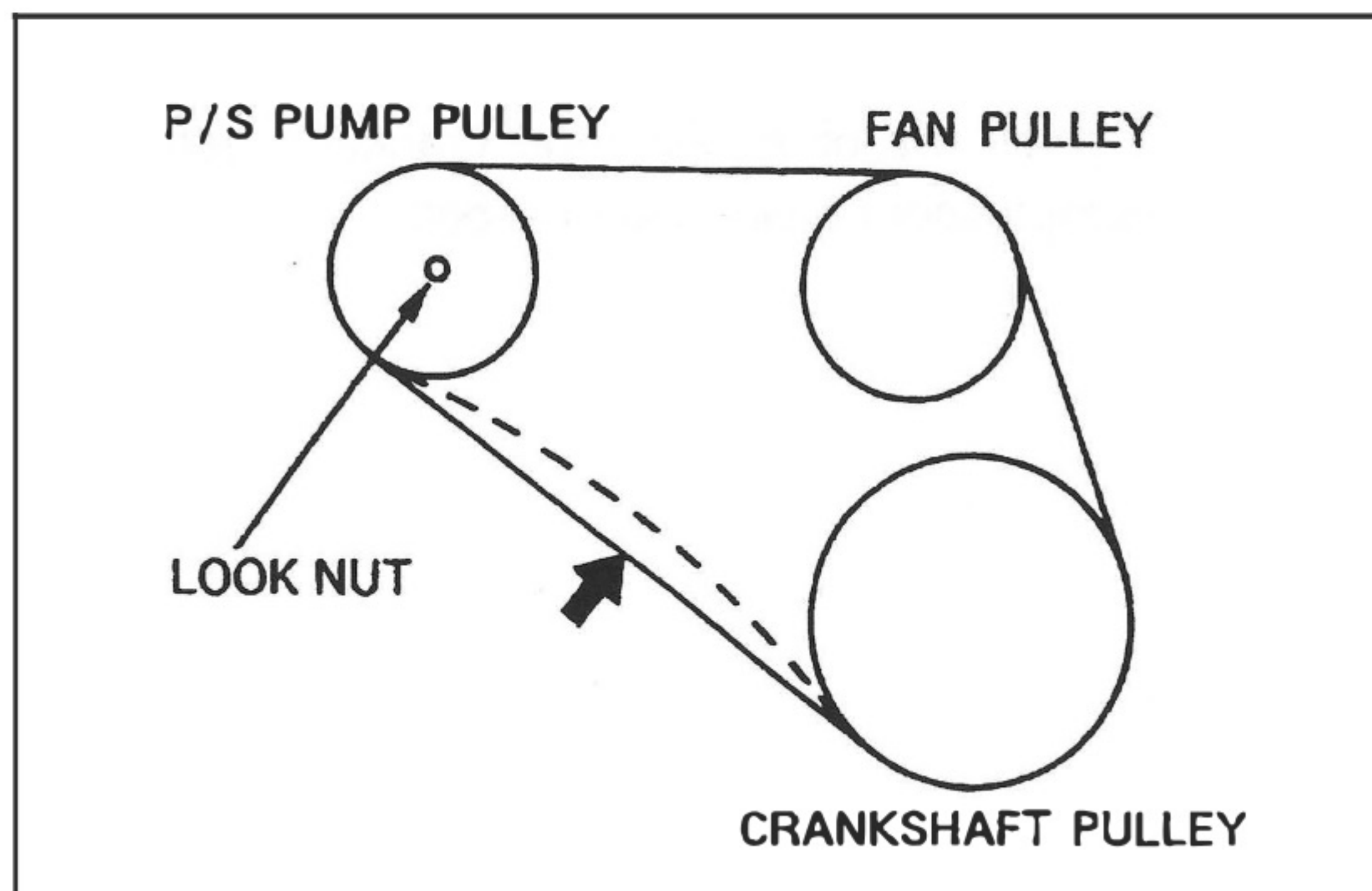

- (l) Adjust the belt tension, check the belt tension using the belt tension gauge.

	Belt tension using the belt tension gauge	Belt deflection at 98N (10 kgf, 22 lbf) force
P/S belt	25 - 40 kgf (55 - 88 lbf)	8.5 - 10 mm

- (m) Tighten the adjusting bolt and lock nut.

Tightening Torque : lock nut
43.1 N•m (440 kgf•cm, 31.7 ft•lbf)

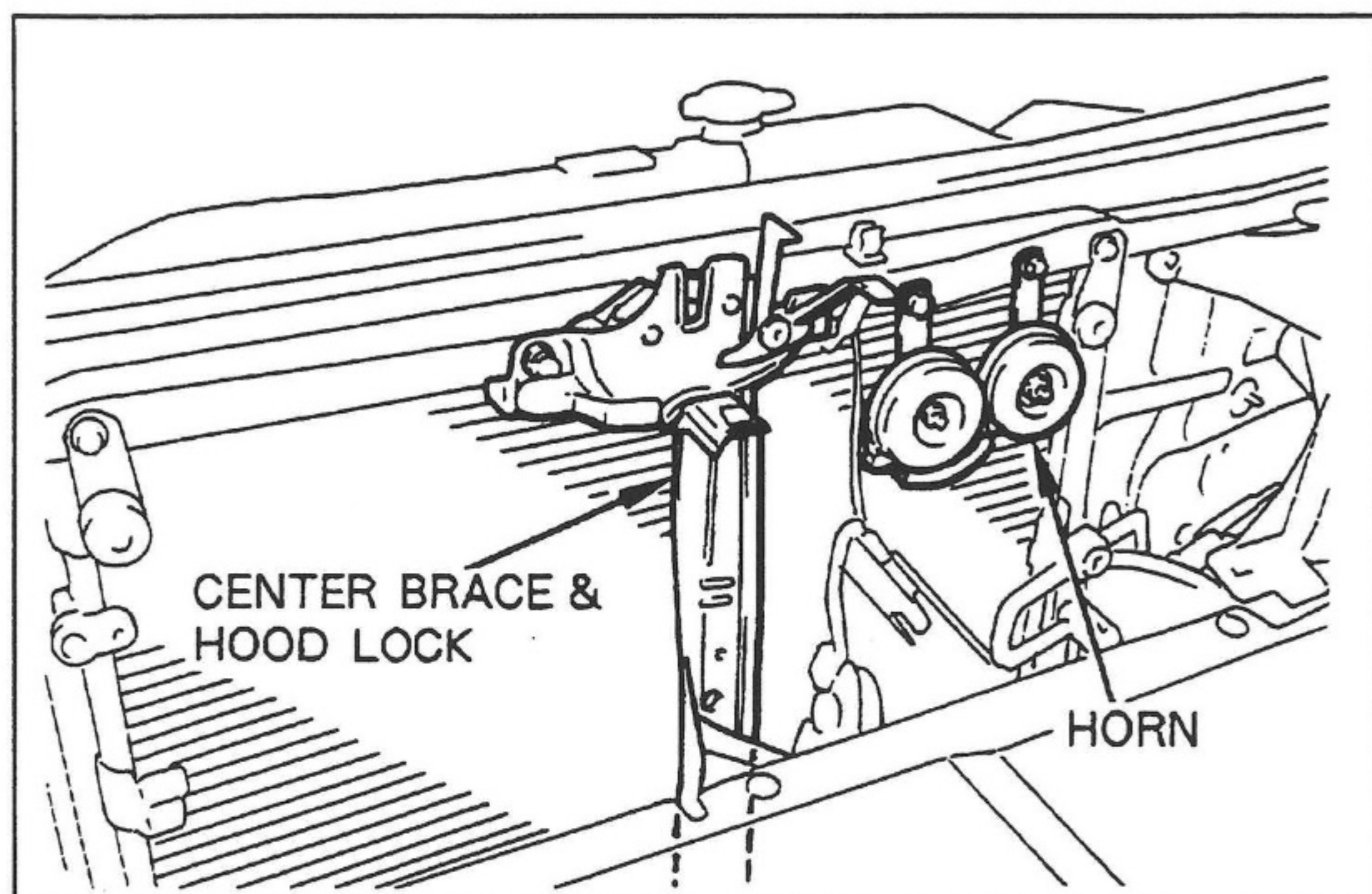
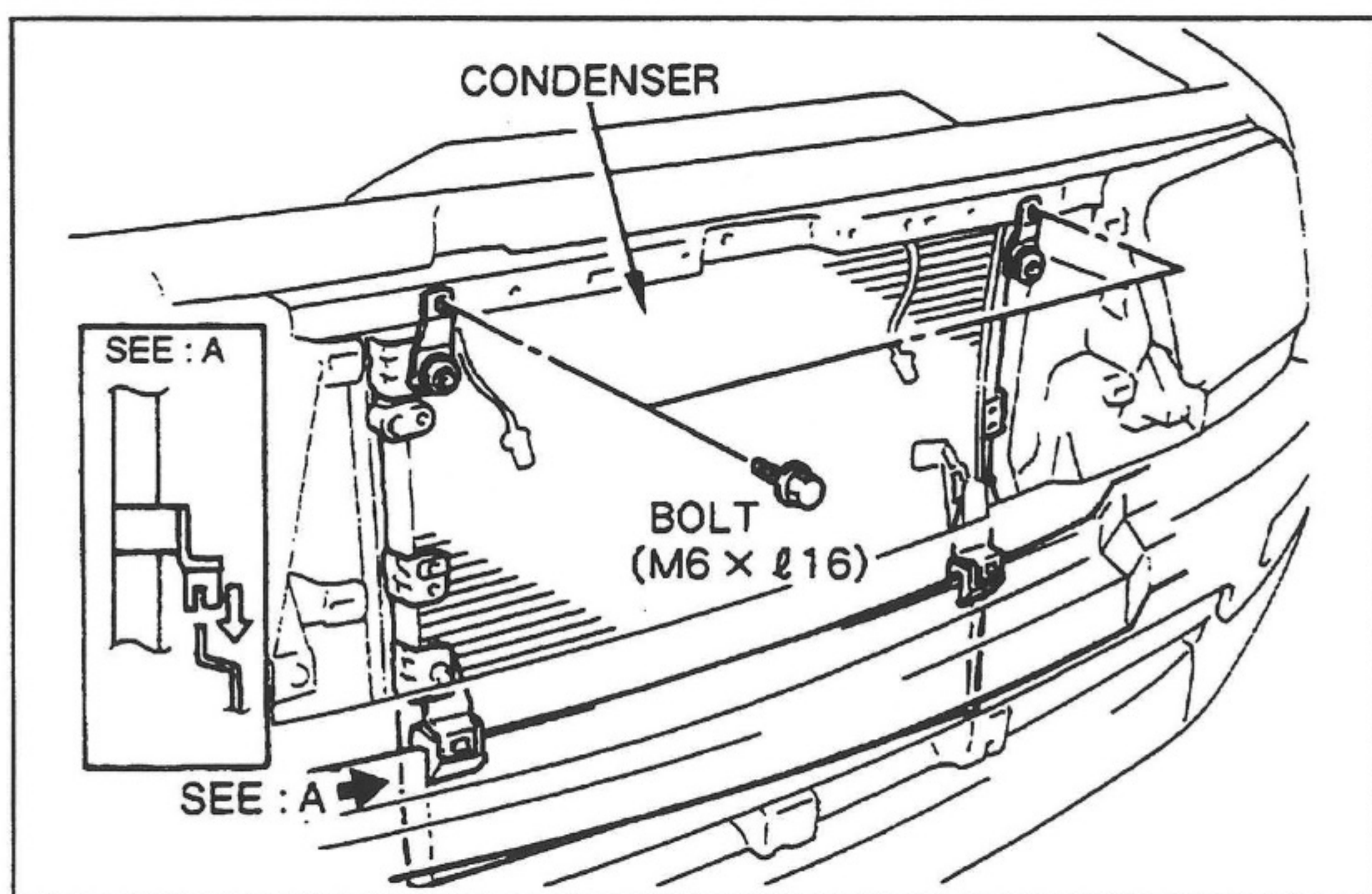
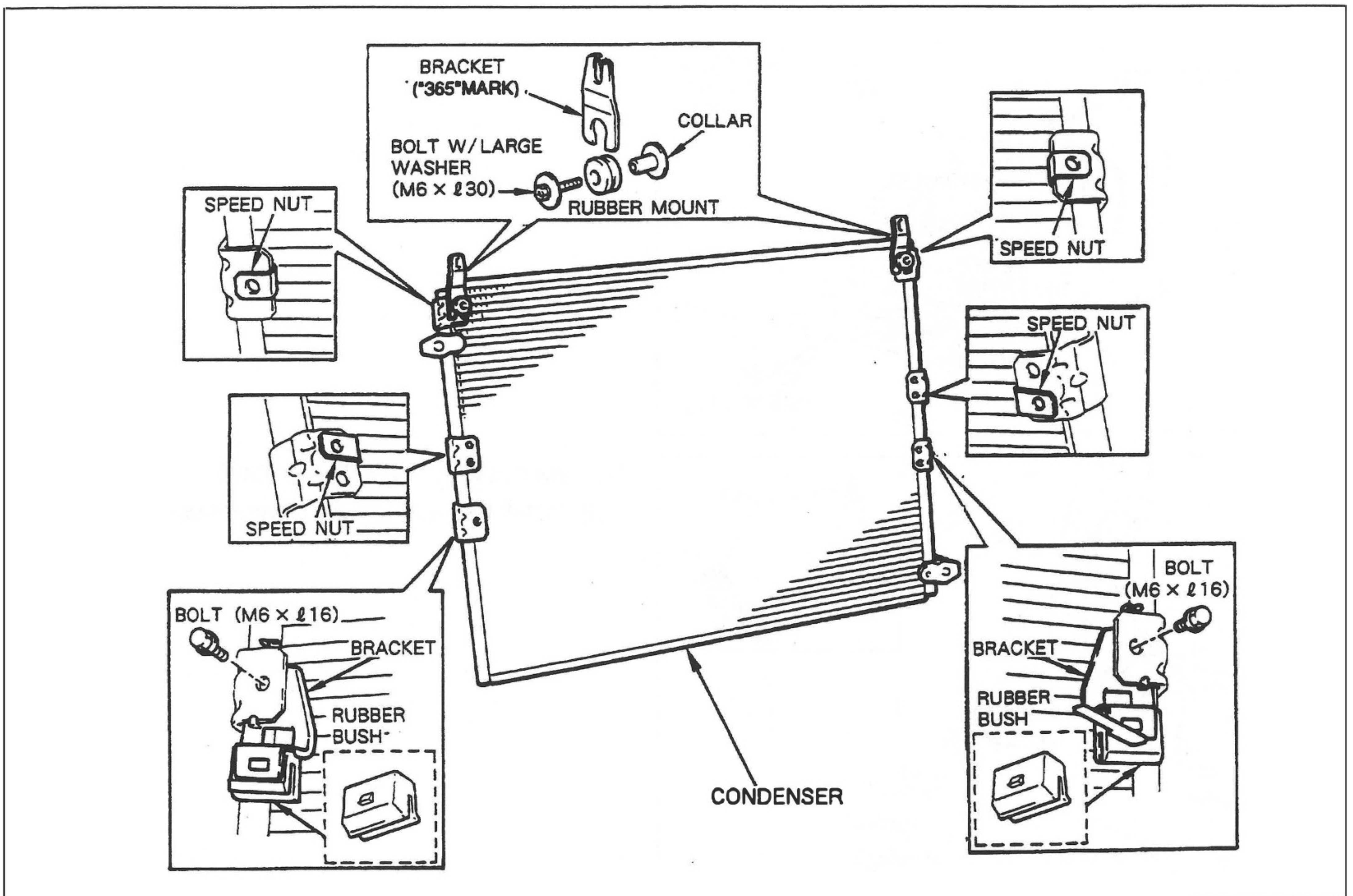

**(3) CONDENSER**

- (a) Assemble the two brackets, two rubber bush, two collars, two rubber mounts, two brackets and speed nuts to the condenser using four bolts.
- (b) Install the condenser in front of the radiator support upper using two bolts.

- (c) Reinstall the center brace, hood lock and horns.

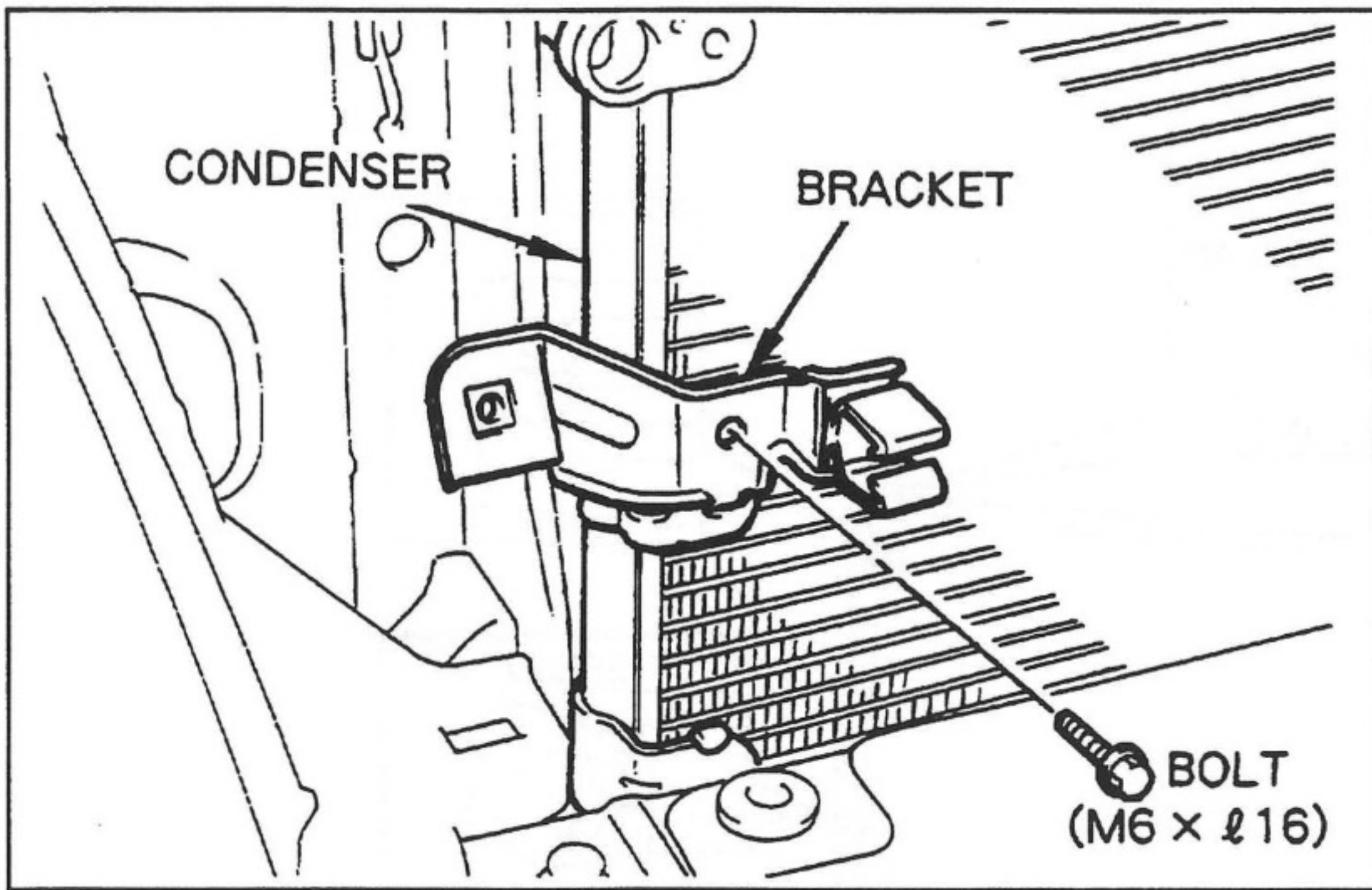

(d) Install the bracket to the condenser using a bolt.

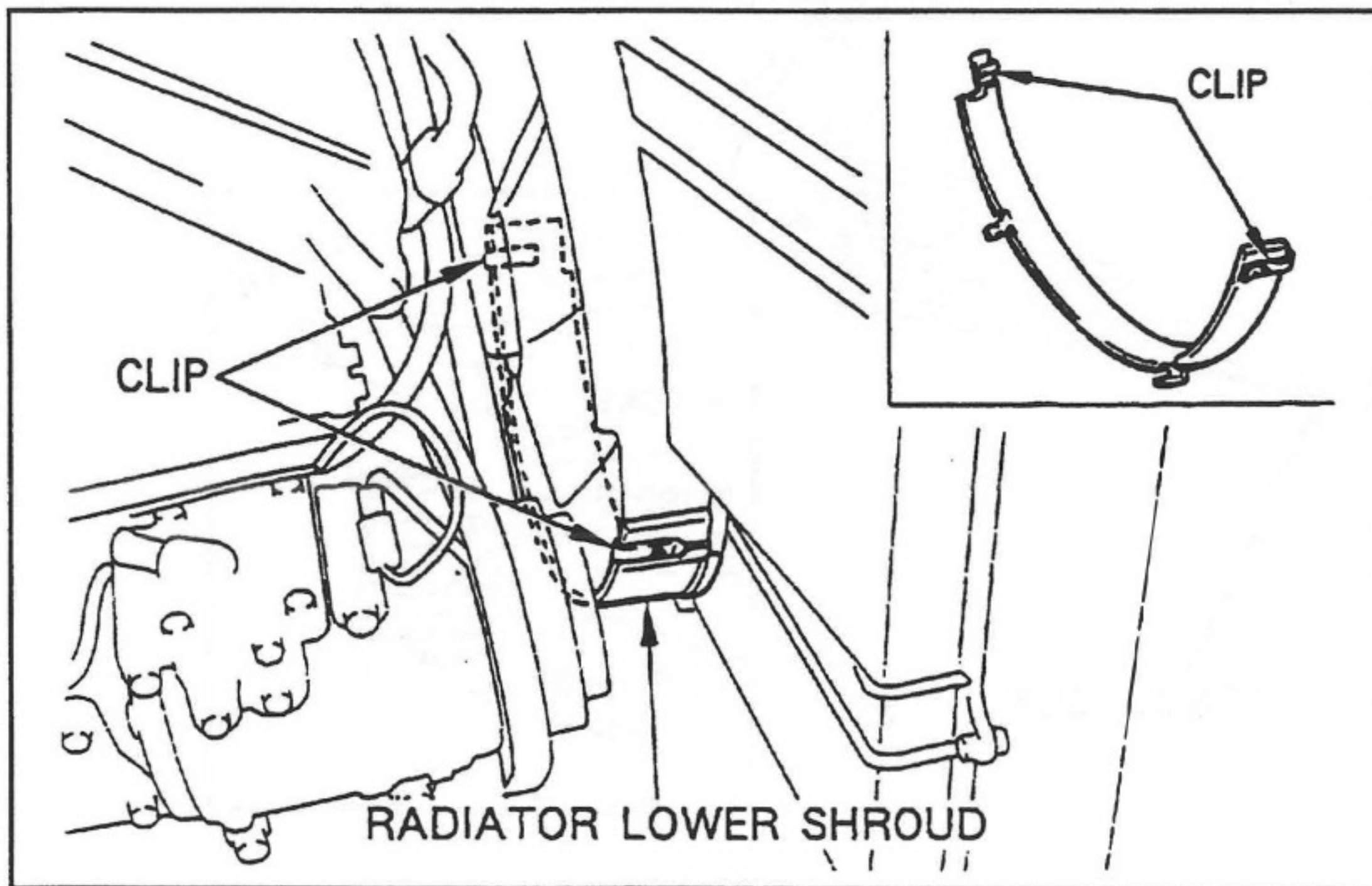

**(4) RADIATOR LOWER SHROUD**

(a) Install the radiator lower shroud using two clips.

• PIPING LAYOUT

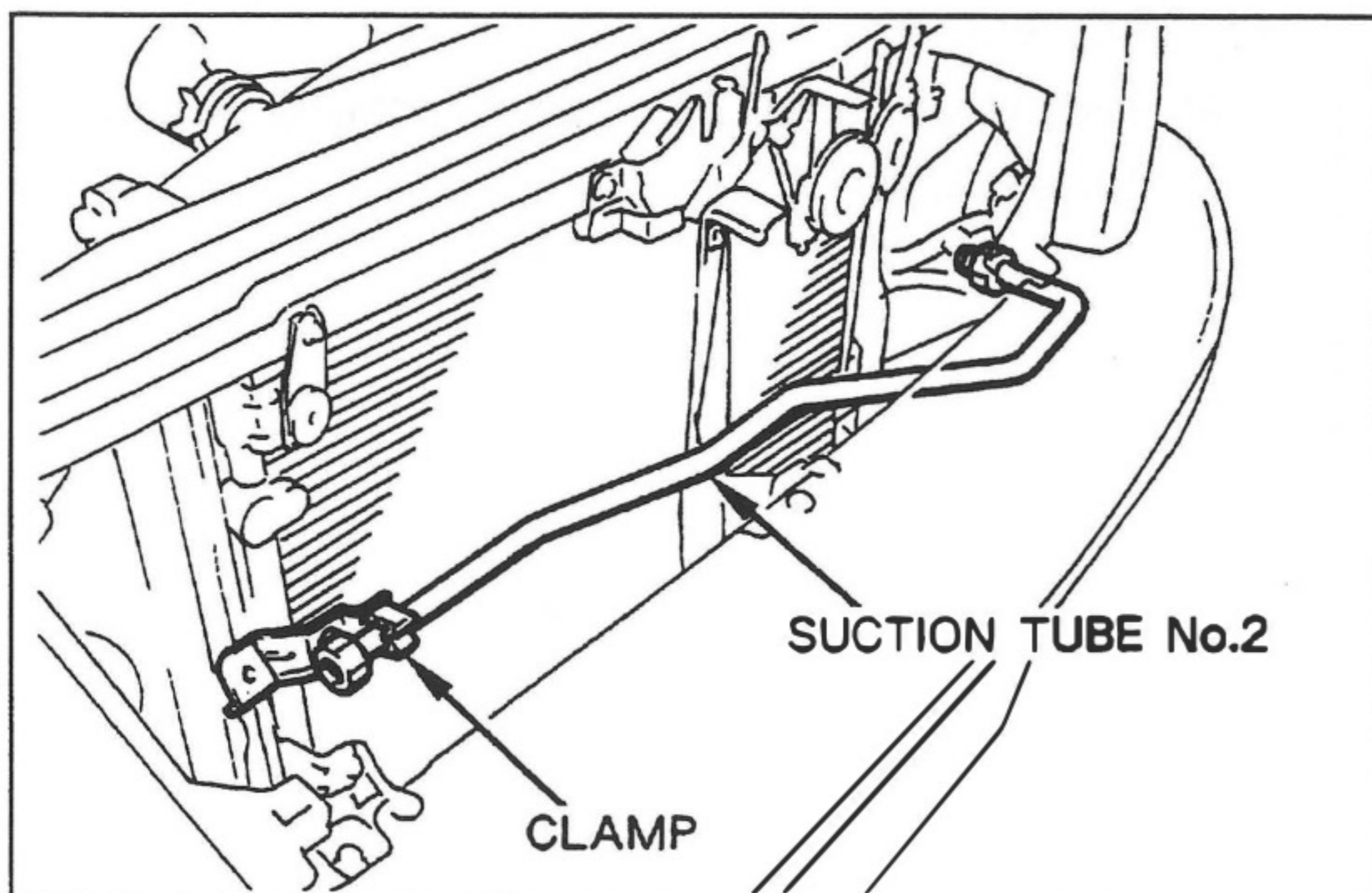
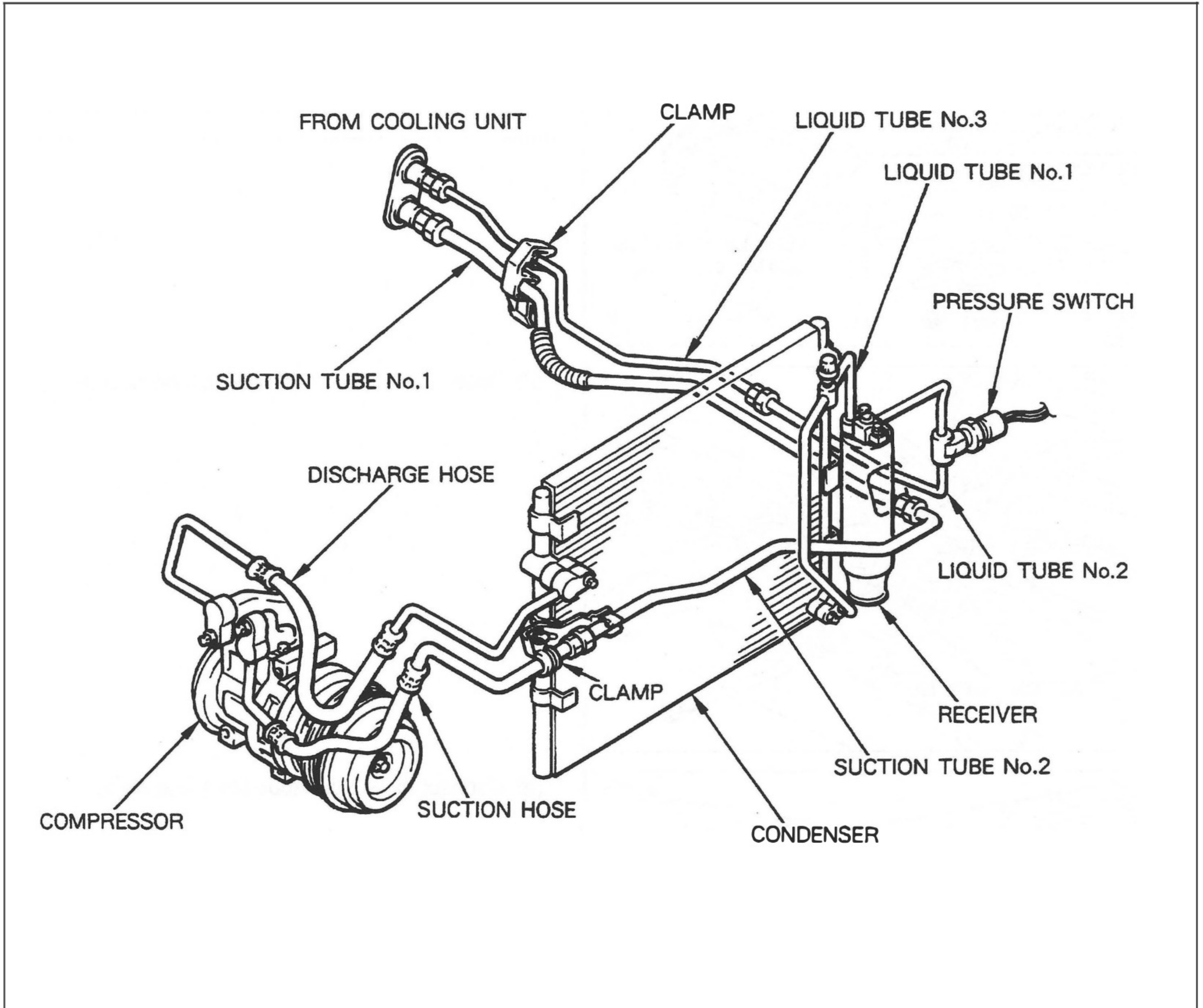

**(5) SUCTION TUBE**

- (a) Route and connect the suction tube No.2 as shown.
- (b) Fasten the suction tube No.2 to the clamp.

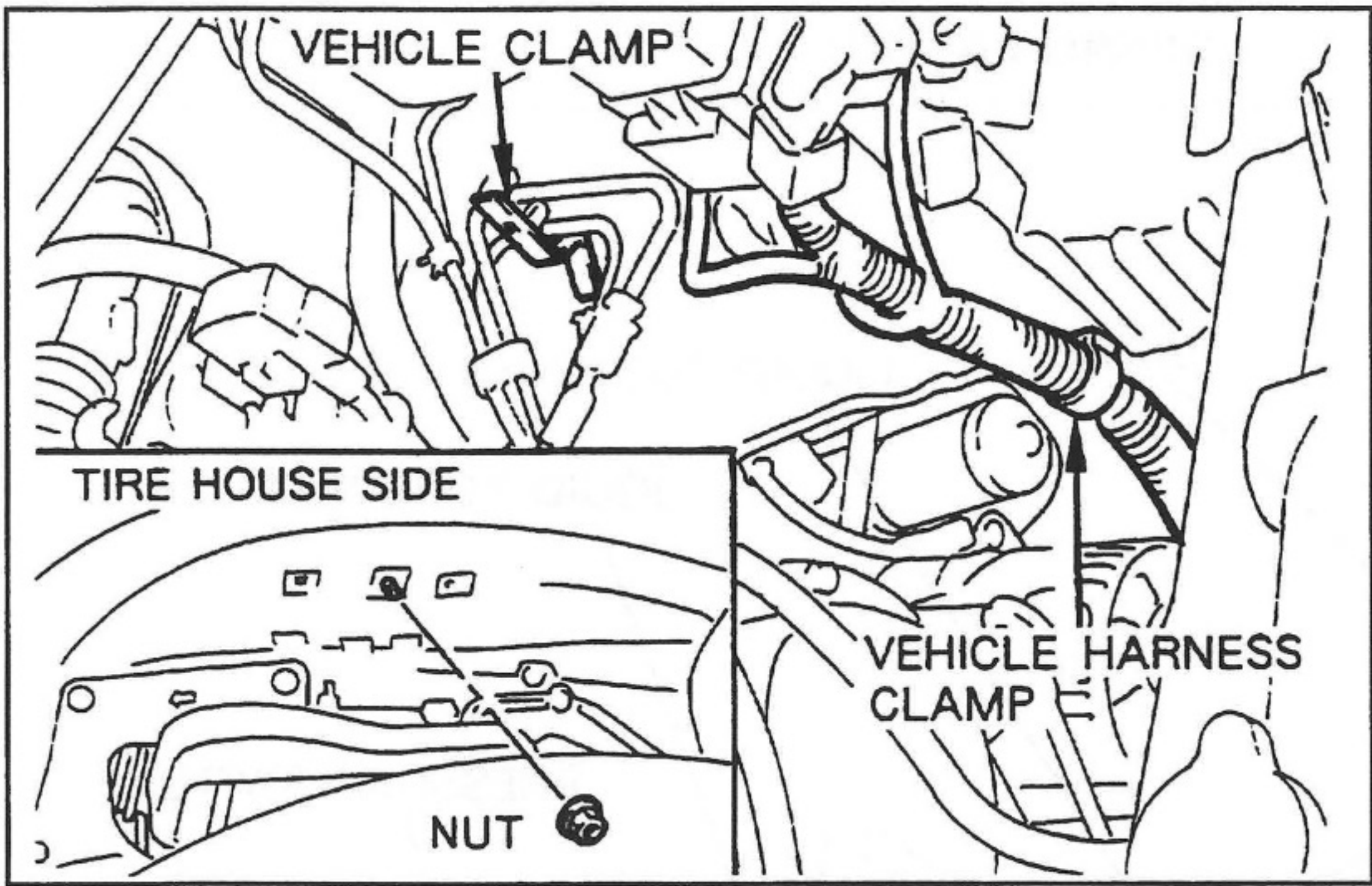

- (c) Temporarily remove the vehicle tube clamp and vehicle harness clamp.

**NOTE**

Disconnect the nut of tube clamp from the tire house side.

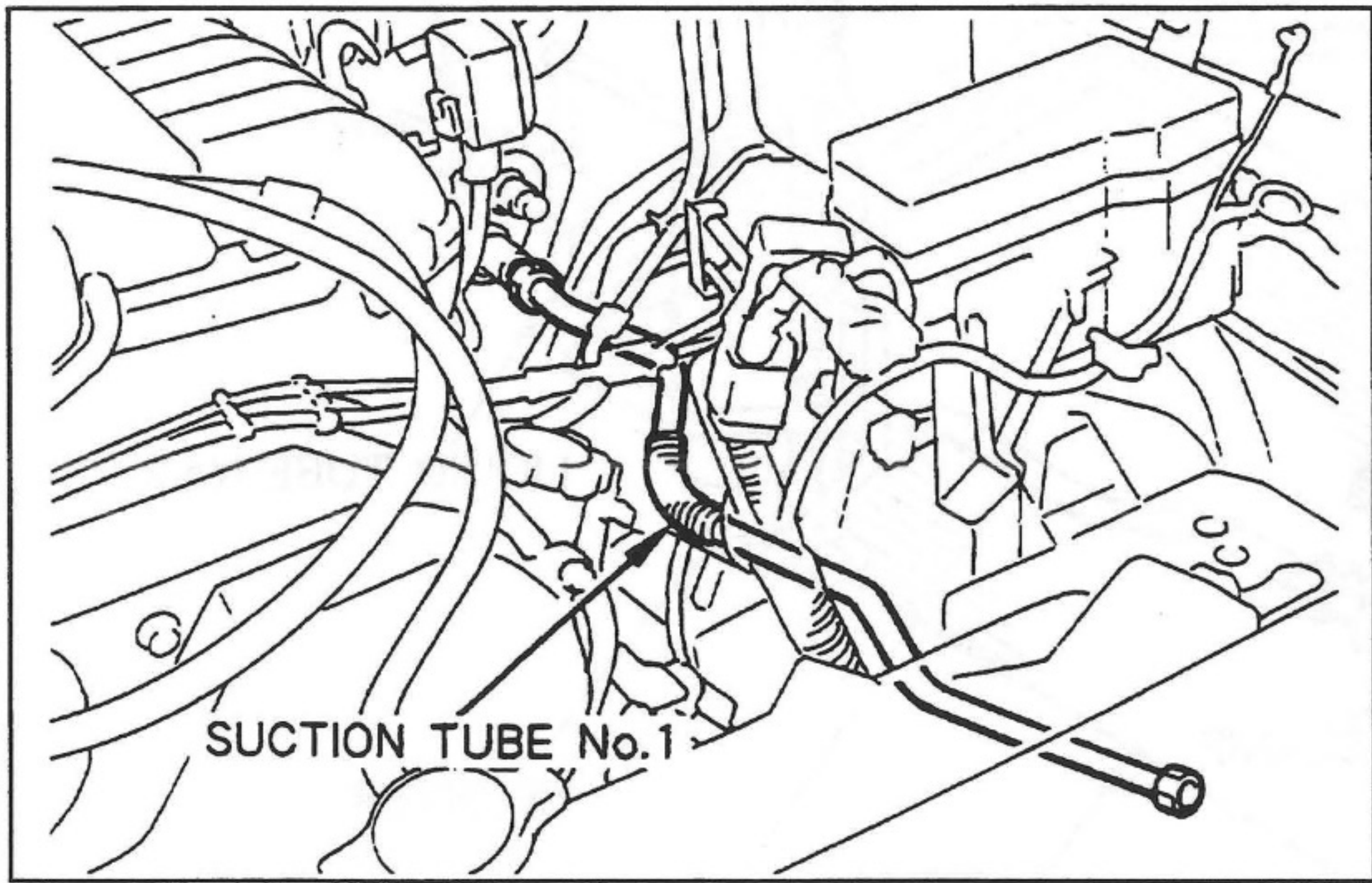

- (d) Route and connect the suction tube No.1 as shown.

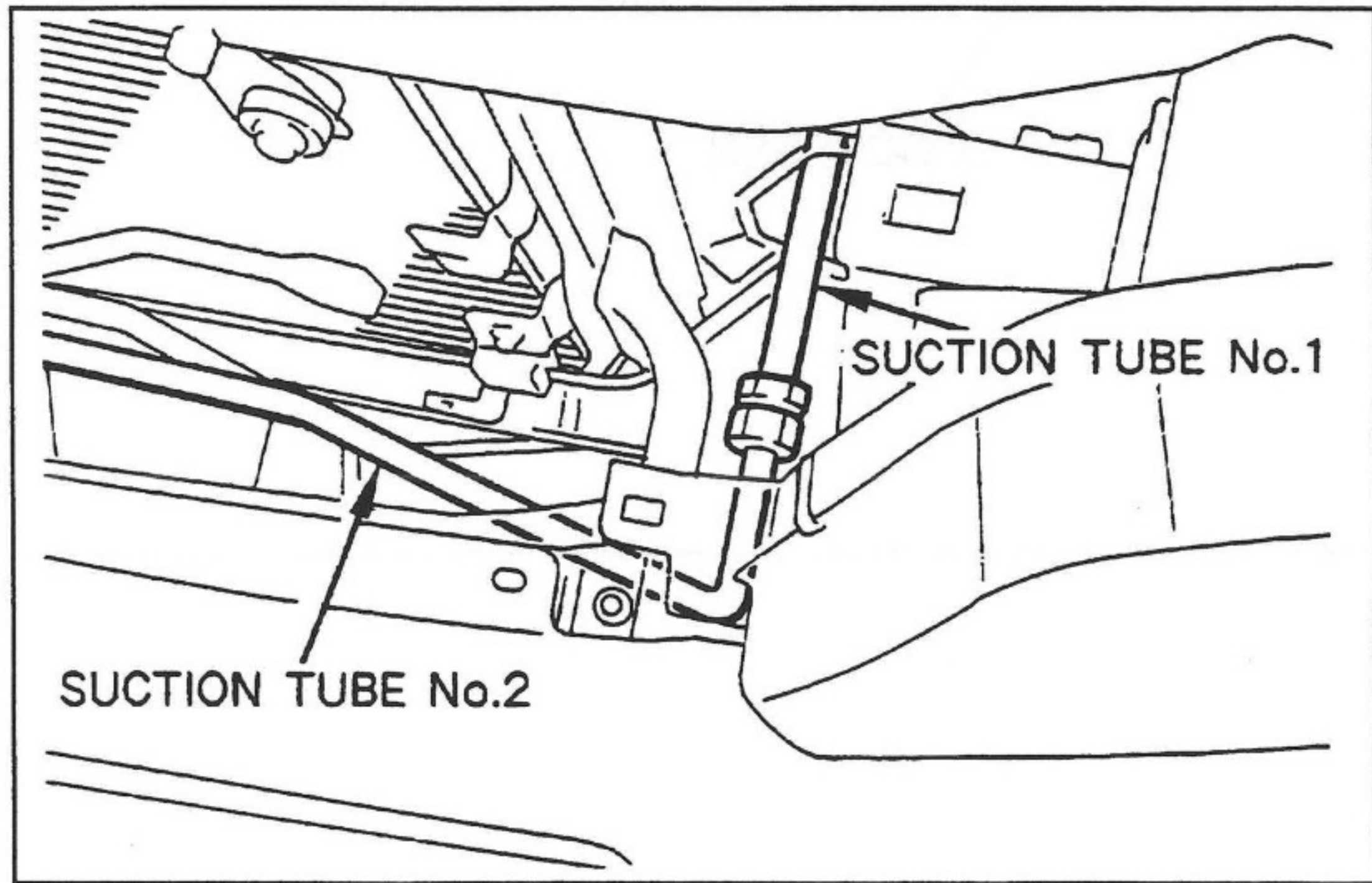

- (e) Connect the suction tube No.1 and No.2.

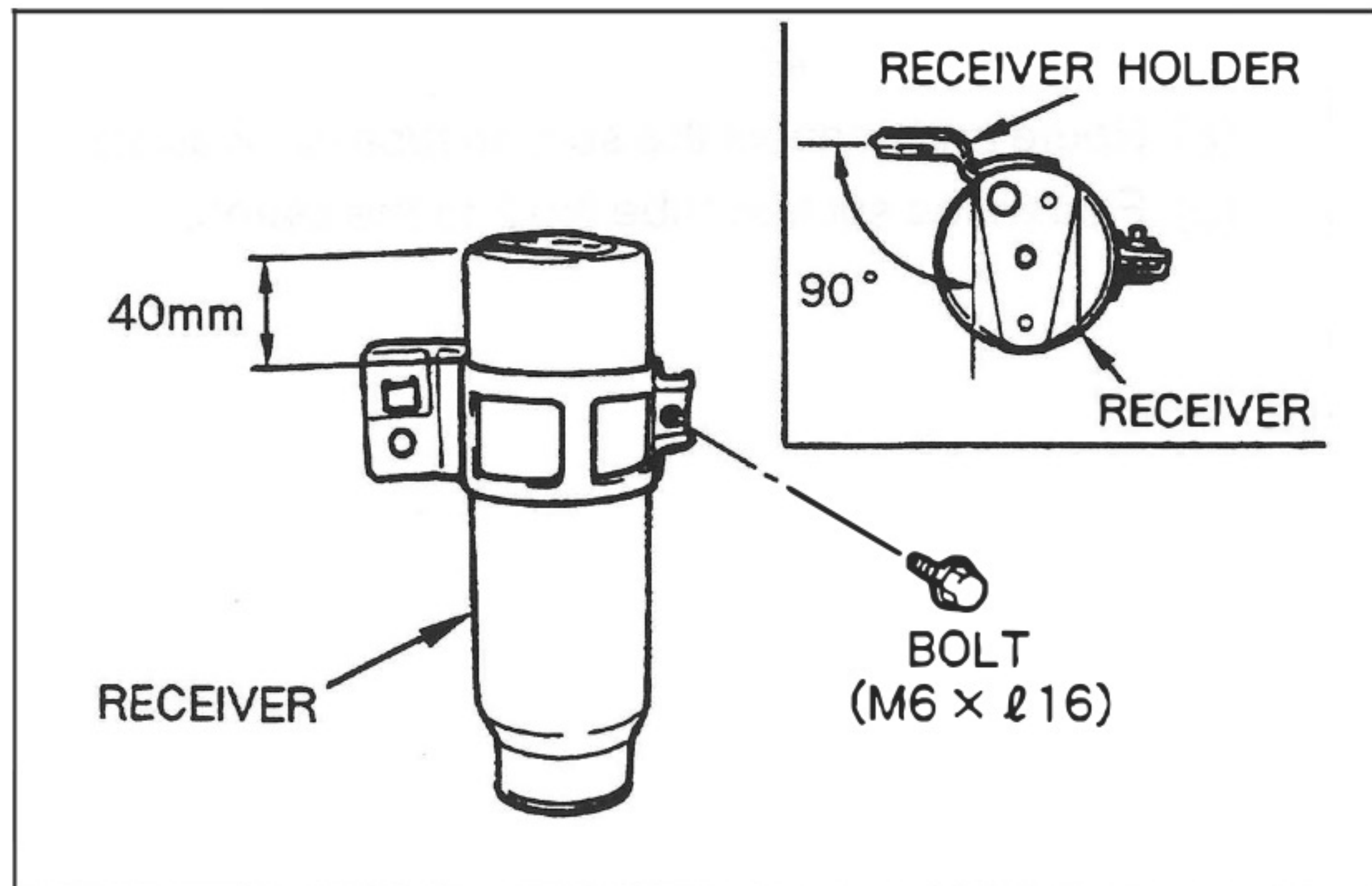

**(6) RECEIVER**

- (a) Temporarily install the receiver to the receiver holder using a bolt.

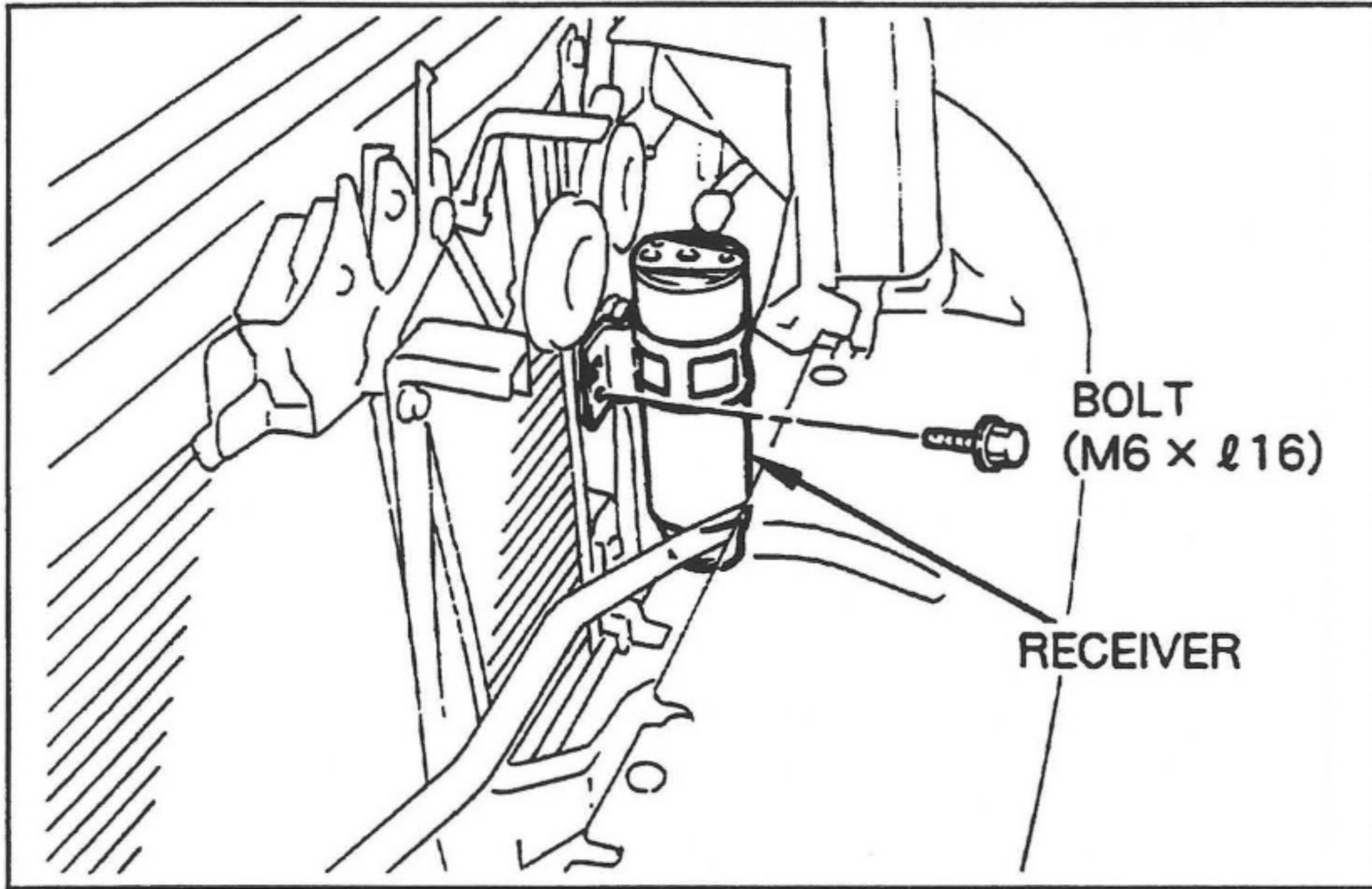

- (b) Install the receiver holder to the condenser bracket using a bolt.

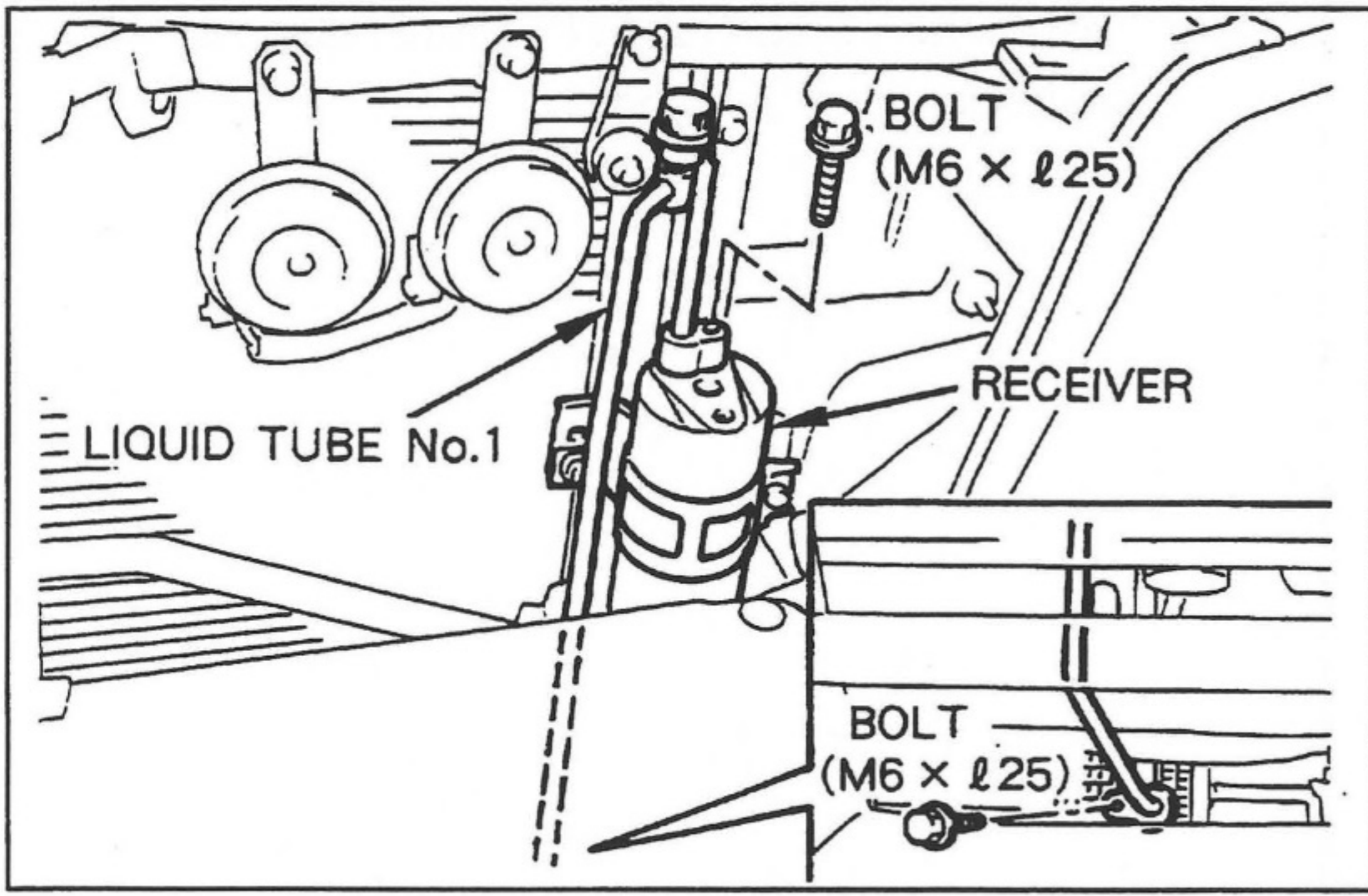

**(7) LIQUID TUBE**

- (a) Connect the liquid tube No.1 from the receiver to the condenser using a bolt.

Tightening Torque
5.4 N•m (55 kgf•cm, 4.0 ft•lbf)

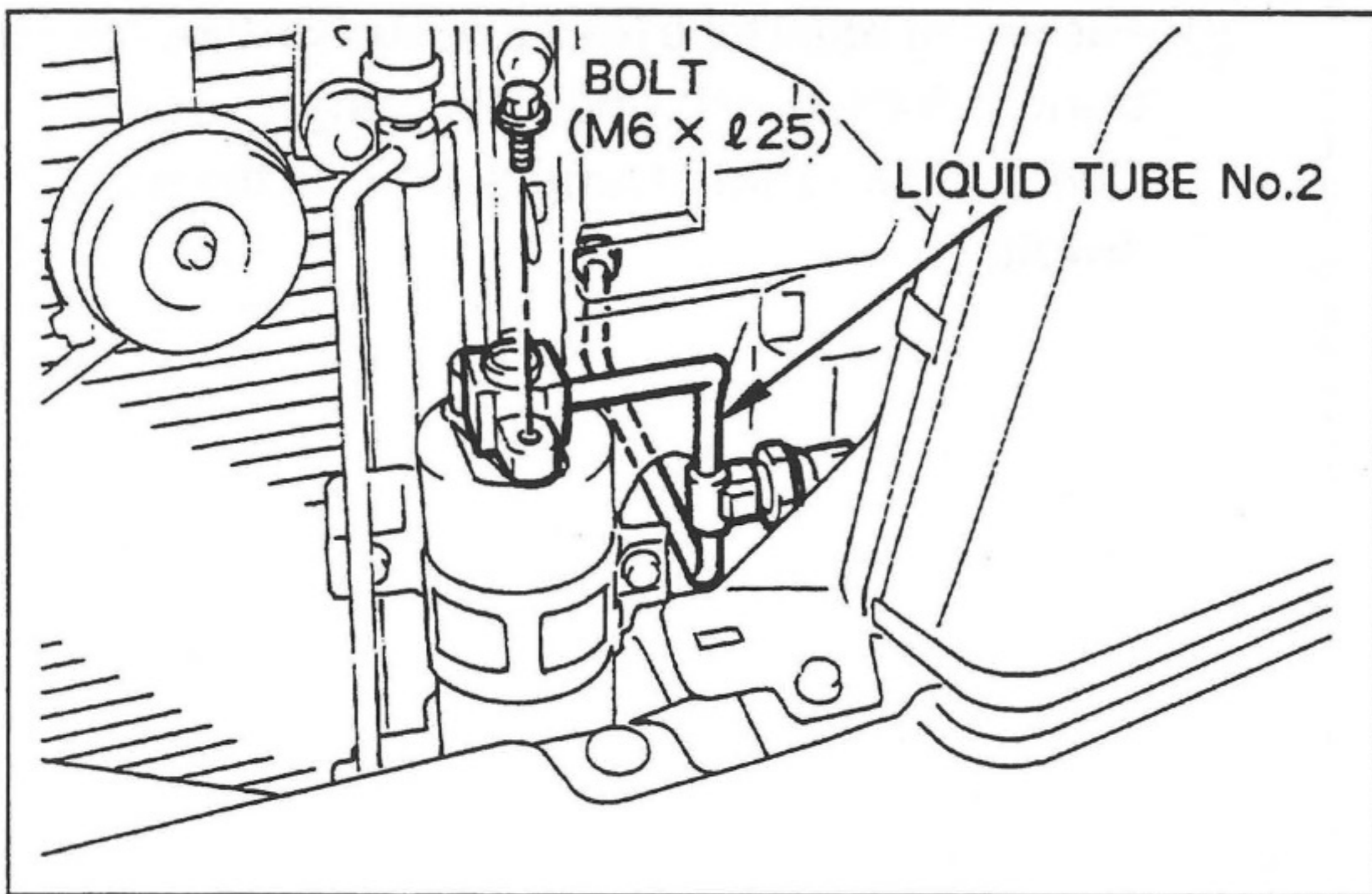

- (b) Connect the liquid tube No.2 to the receiver using the bolt.

Tightening Torque
5.4 N•m (55 kgf•cm, 4.0 ft•lbf)

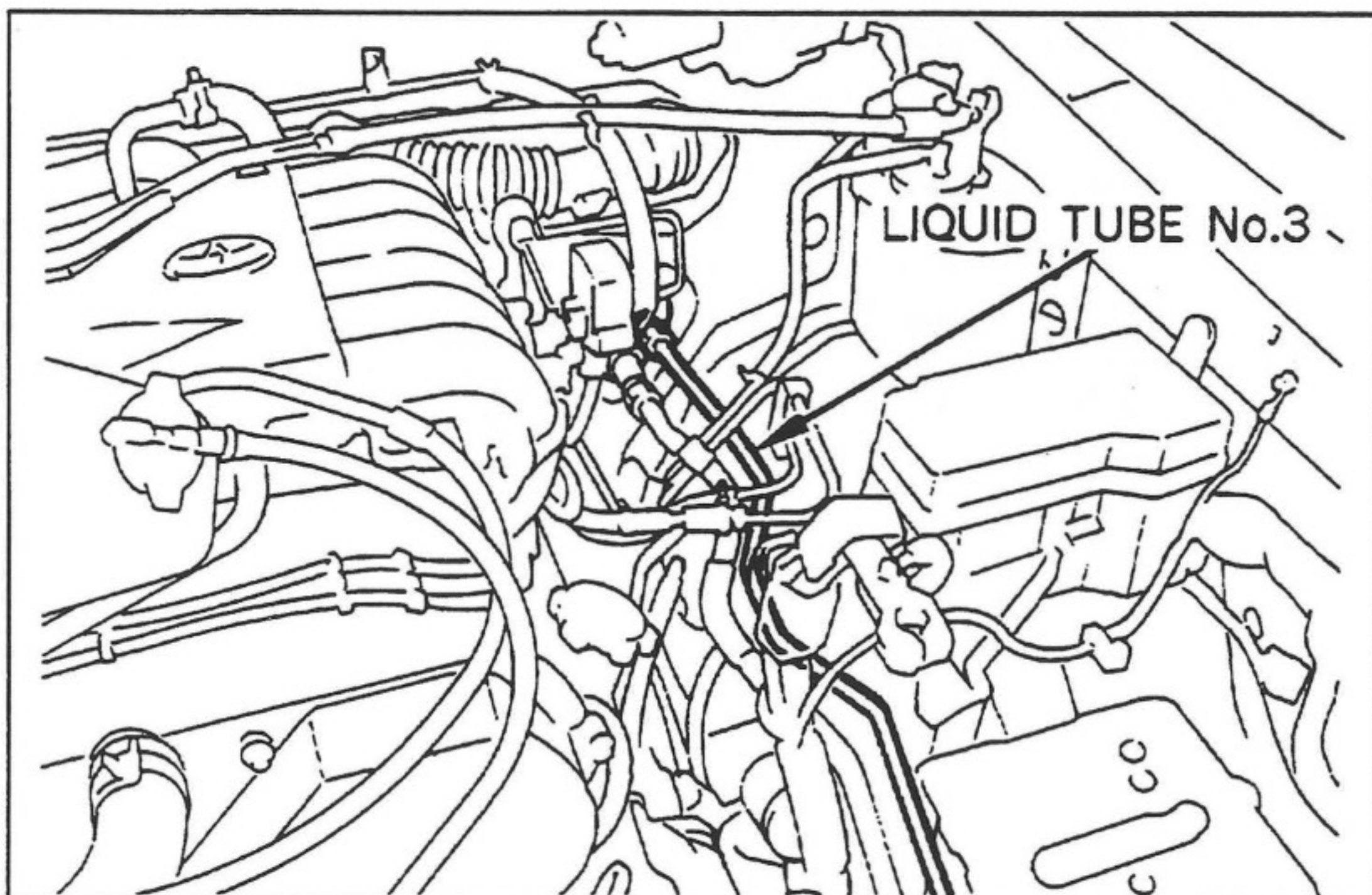

- (c) Route and Connect the liquid tube No.3 as shown.

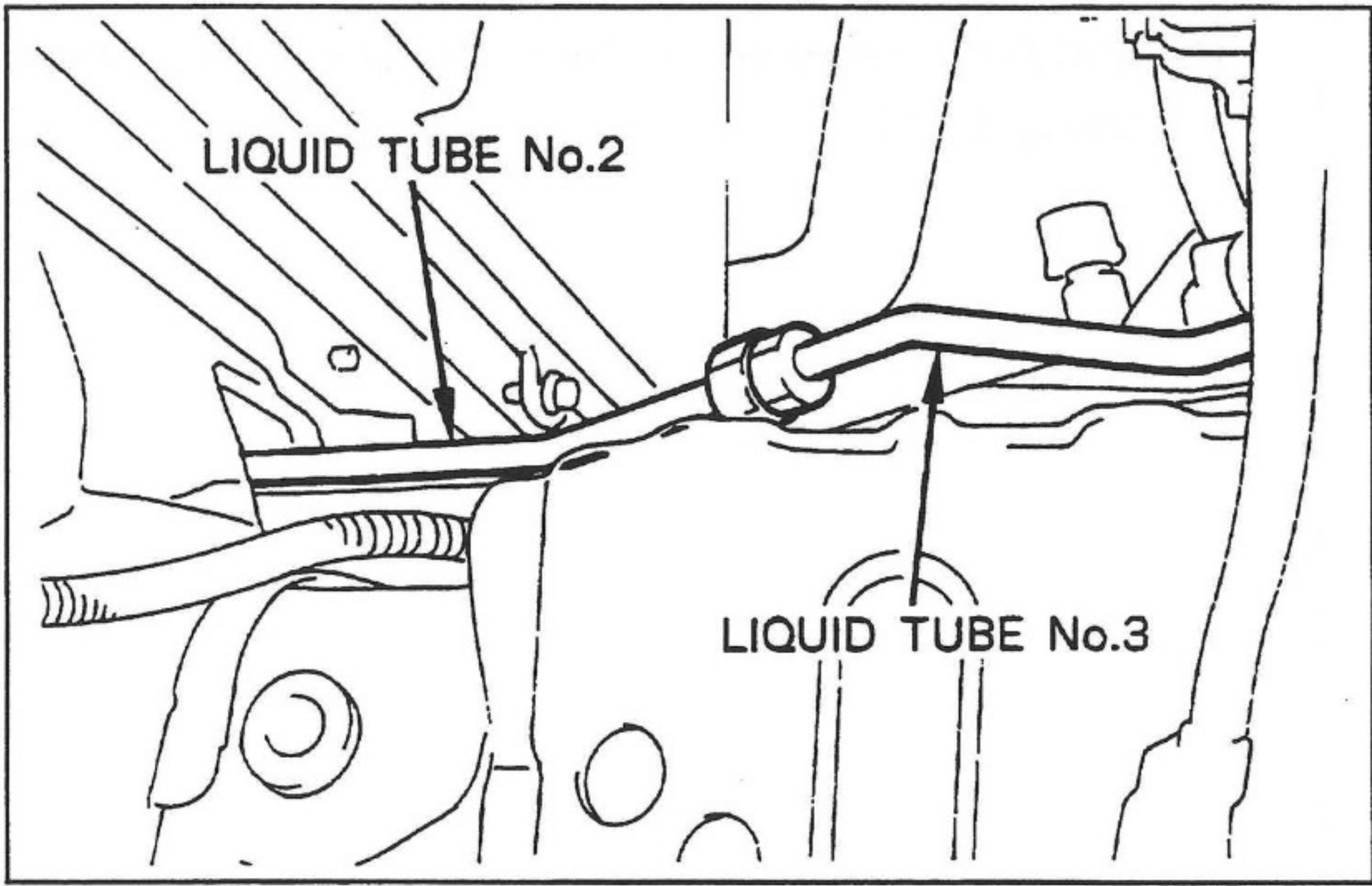

(d) Connect the liquid tube No.2 and No.3.

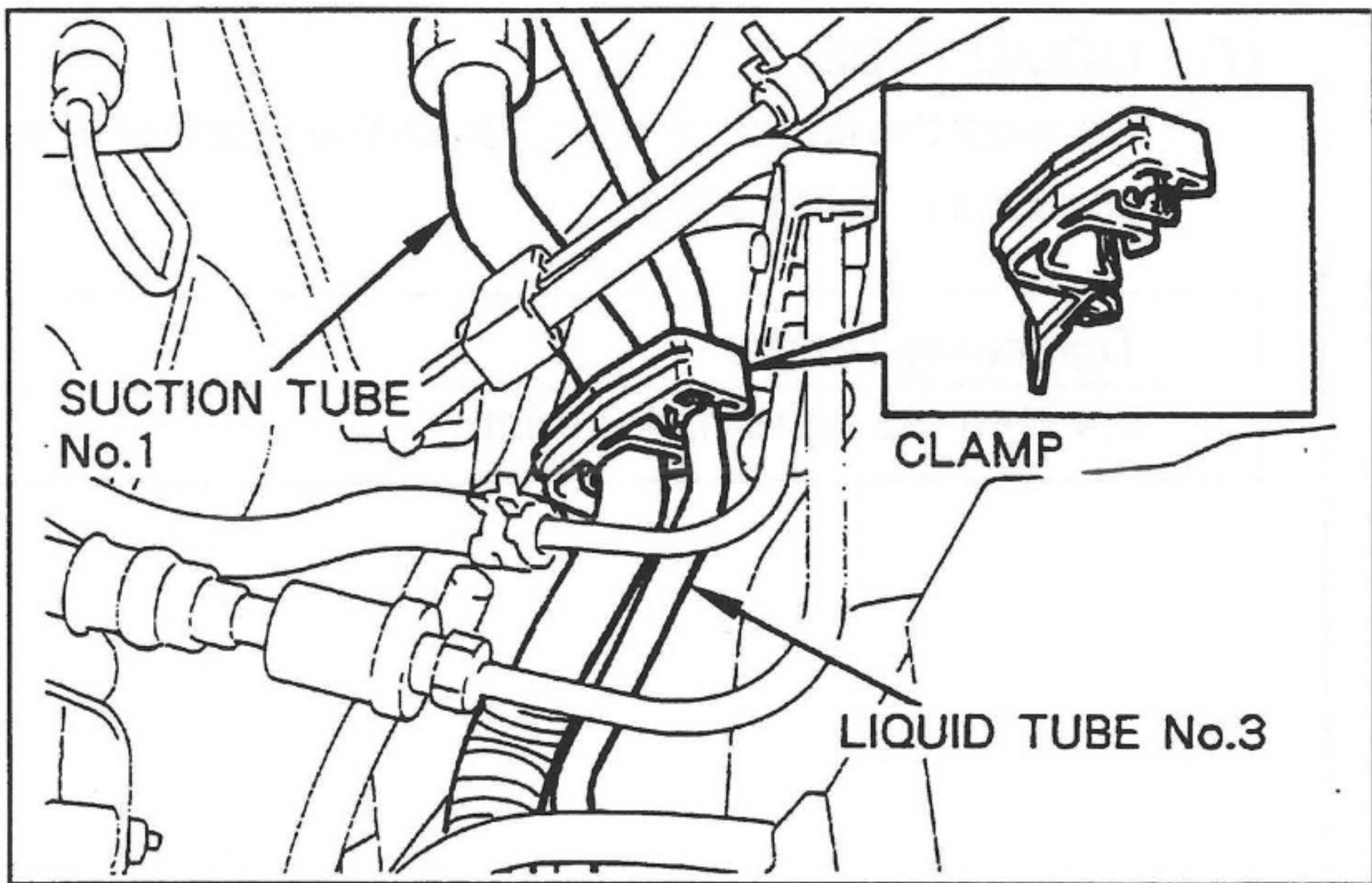

(e) Fasten the suction tube No.1 and liquid tube No.3 to the body using the clamp.

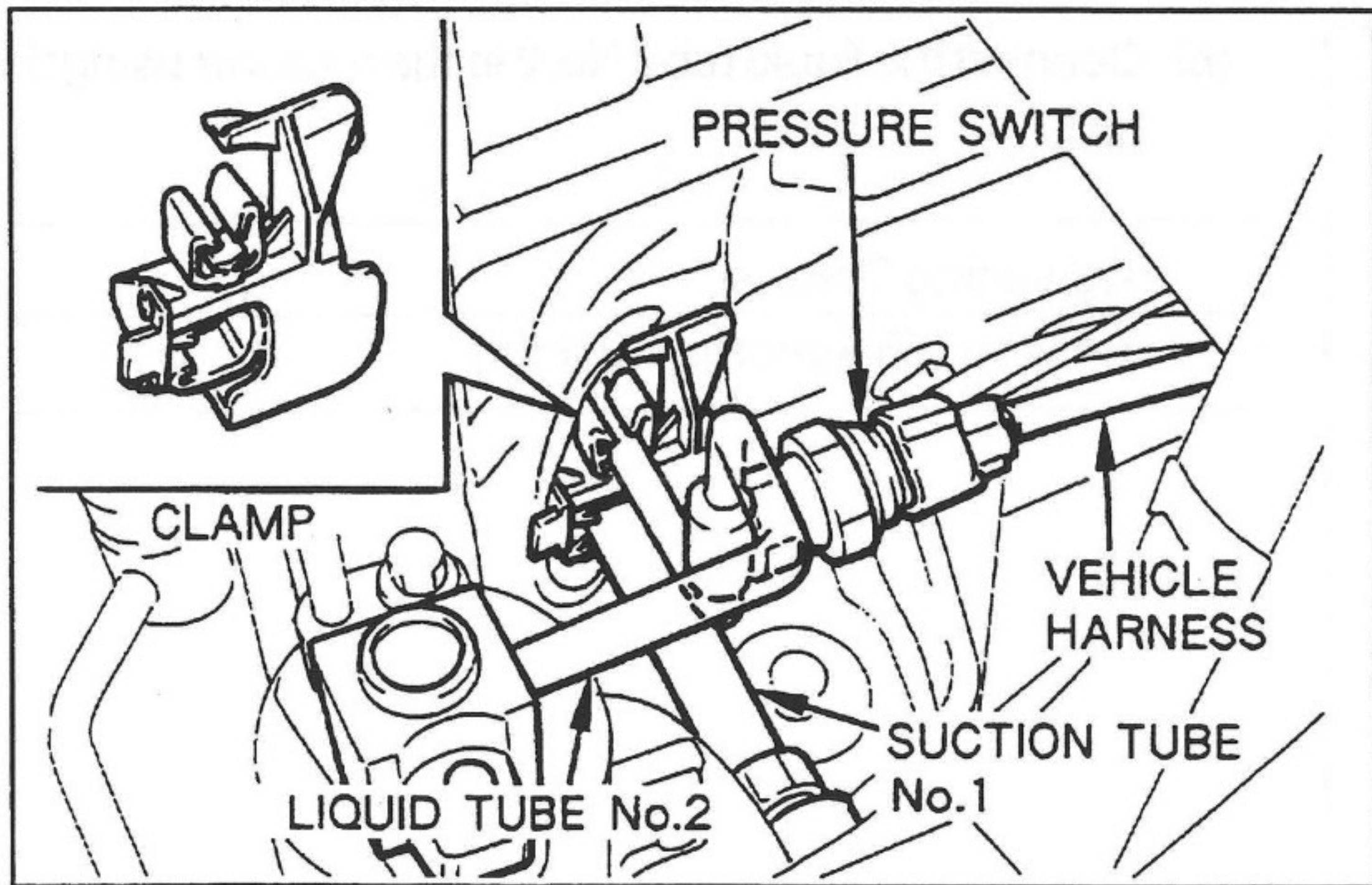

(f) Fasten the liquid tube No.2 and suction tube No.1 to the radiator support panel hole using the clamp.

(g) Connect the vehicle harness (2-P) to the pressure switch.

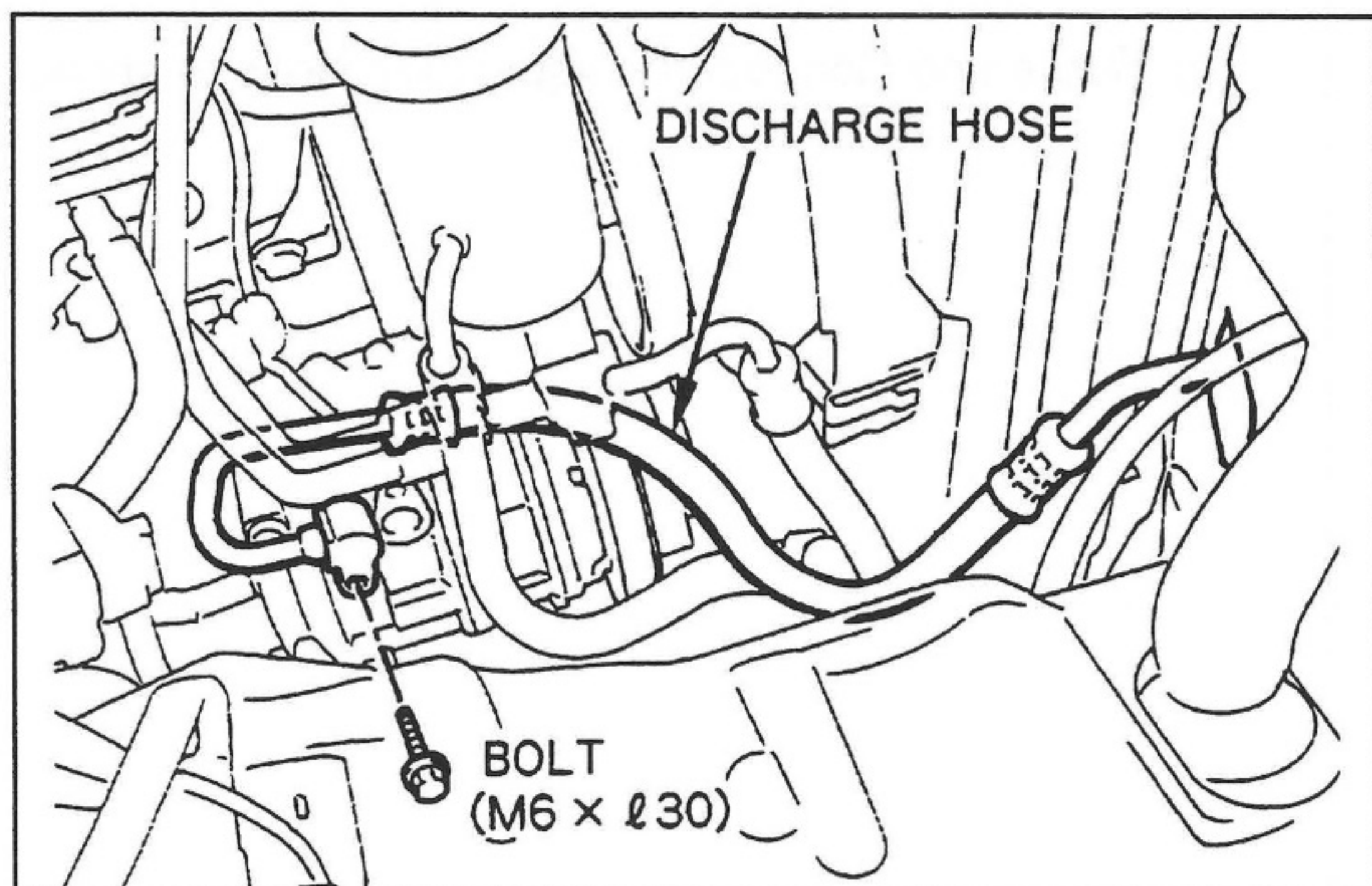

### (8) DISCHARGE HOSE

(a) Connect the discharge hose from the compressor to the condenser.

Tightening Torque : compressor side
-------------------------------------

9.8 N•m (100 kgf•cm, 7.2 ft•lbf)
----------------------------------

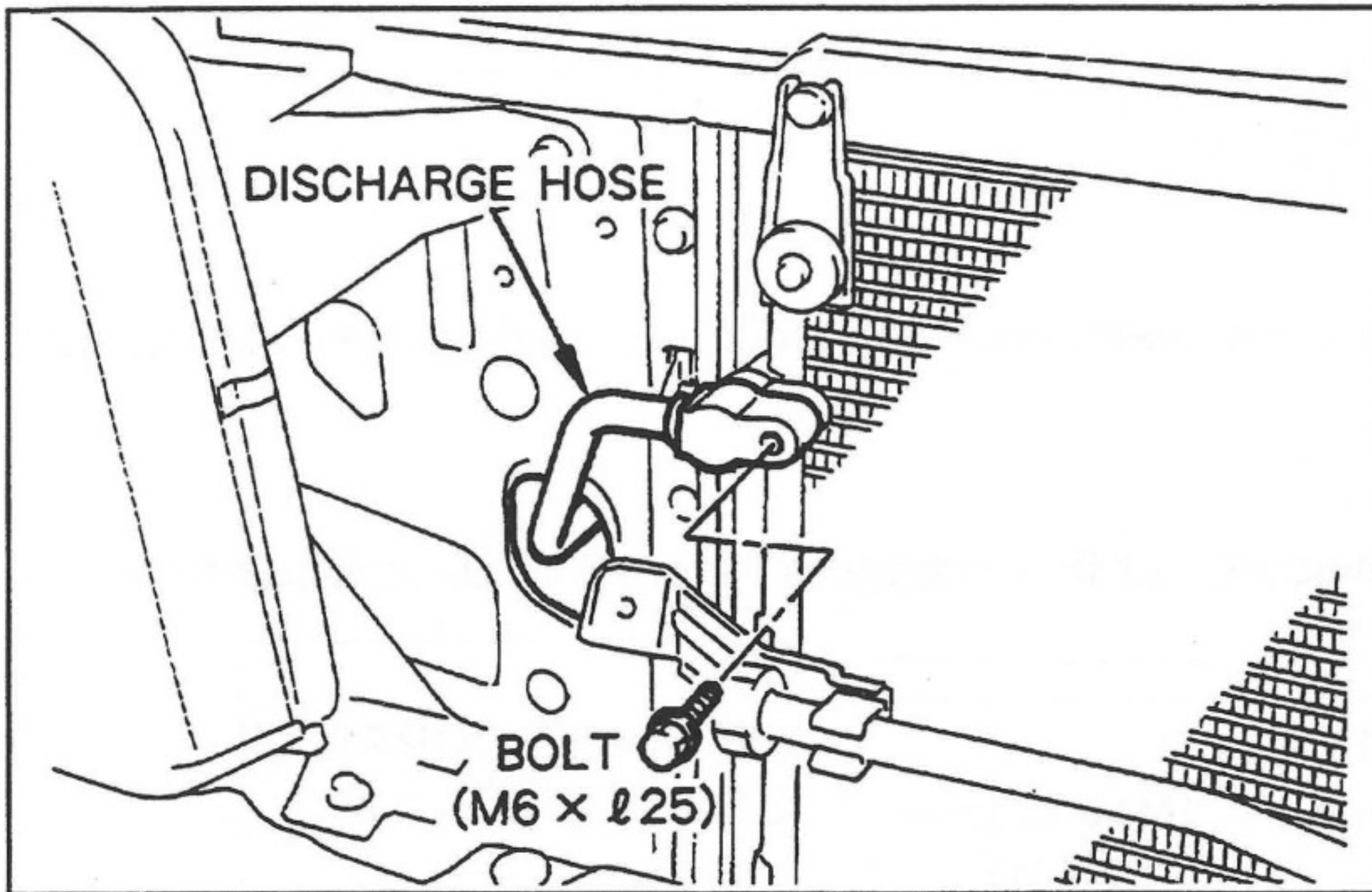

(b) Connect the discharge hose to the condenser.

Tightening Torque : condenser side
5.4 N•m (55 kgf•cm, 4.0 ft•lbf)

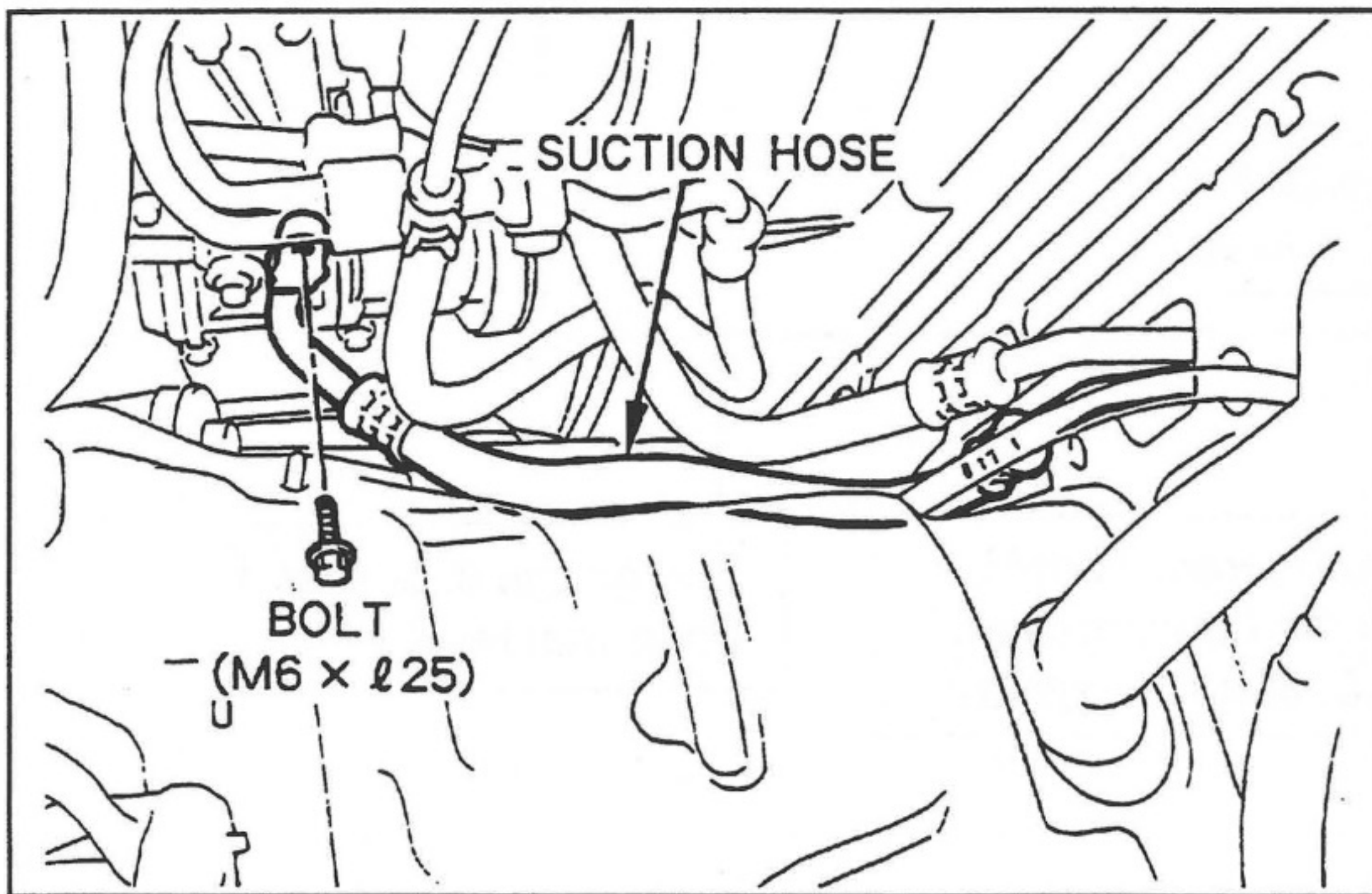

**(9) SUCTION HOSE**

(a) Connect the suction hose from the compressor to the suction tube No.2.

Tightening Torque : compressor side
9.8 N•m (100 kgf•cm, 7.2 ft•lbf)

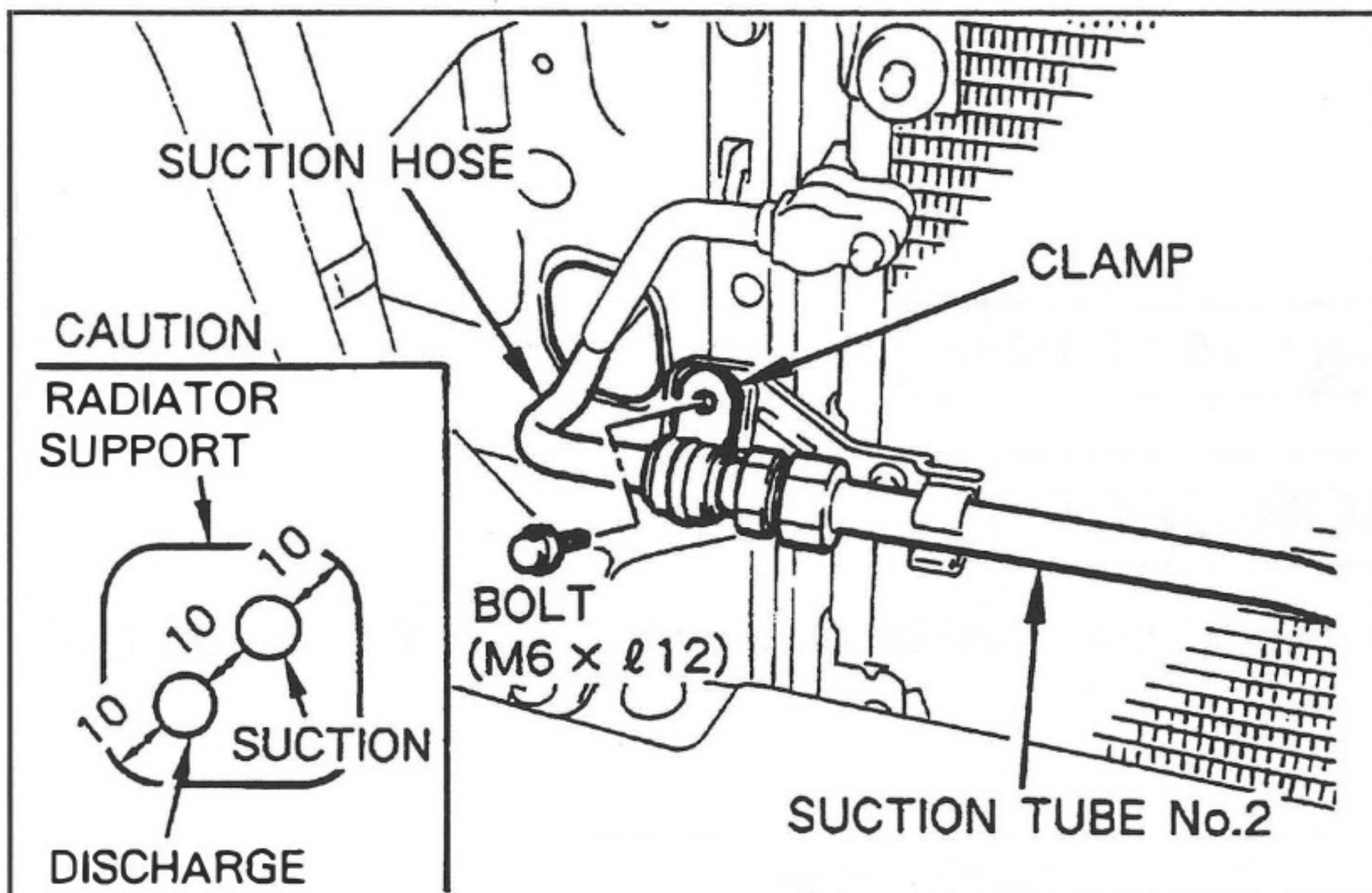

(b) Connect the suction hose to the suction tube No.2.  
(c) Fasten the suction hose to the bracket using the clamp and a bolt.

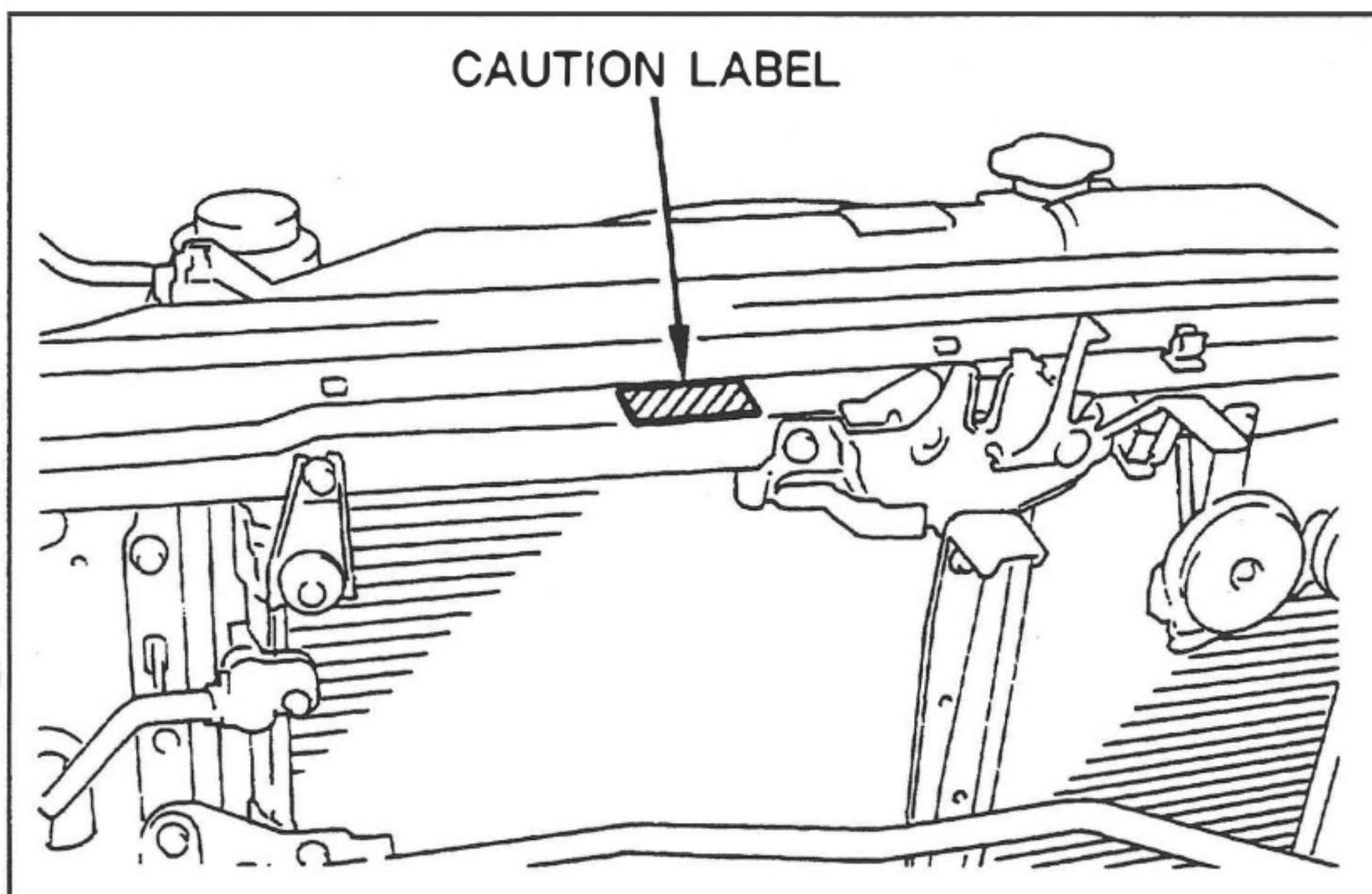

**(10) CAUTION LABEL**

(a) Attach the caution label onto the radiator upper baffle.

**REINSTALLATION**

Reinstall the all removed parts.

# 3. AFTER INSTALLATION

## 3-1 CHARGING REFRIGERANT (HFC-134a)

(1) Automatic charging machine

Before evacuating air or charging refrigerant using the automatic charging machine, read the relevant manuals thoroughly.

(2) Charging cylinder

When charging refrigerant using a charging cylinder, evacuate air then charge refrigerant as described below.

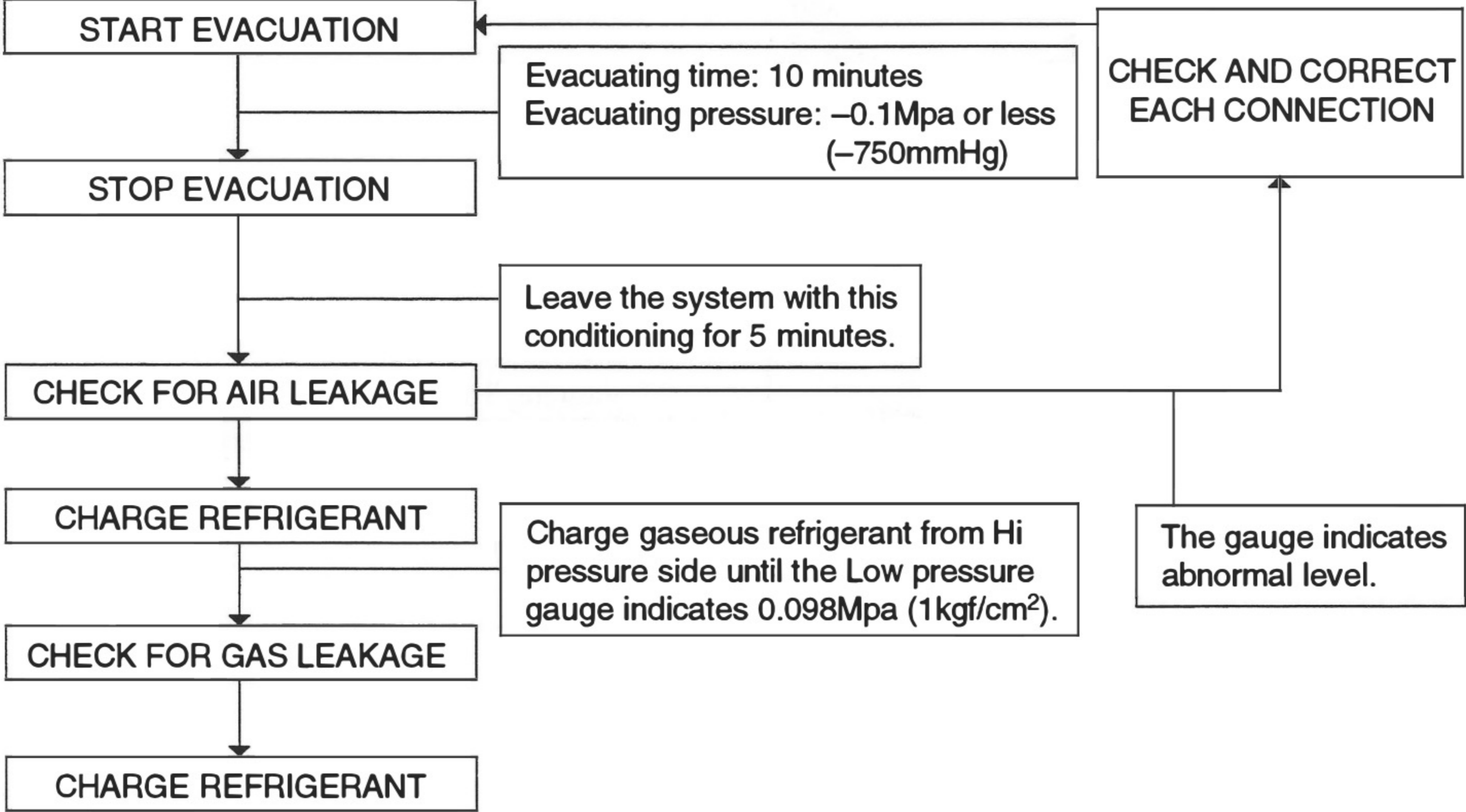

STANDARD AMOUNT OF REFRIGERANT	750 ± 50g (1.65 ± 0.11lbs)
--------------------------------	----------------------------

## 3-2 RE-ADJUSTMENT OF COMPRESSOR BELT

To correct belt deflection caused by initial elongation, the air conditioning must be operated for at least 5 minutes before the final adjustment of the belt.

	Belt deflection [at 98N(10kgf, 22lbf)force]	Belt tension [N (kgf)]
Vehicle equipped with 5VZ E/G	5 - 7 mm	30 ± 10 kgf

### ! CAUTION

1. Excessive tension of belt may have an adverse effect on bearings, while excessive slackness can cause belt to slip, and makes abnormal noise or shortening the belt life.
2. The belt tension must be measured between the specified pulleys as indicated in this manual.
3. The belt tension must be adjusted to the center of the specified belt tension range.

### 3-3 RESTORE THE VEHICLE

Reinstall all the parts of vehicle that have been temporarily removed.

#### ! CAUTION

1. In particular, improper installation of instrument panel's parts, improper tightening of tapping screws or loose connectors may cause abnormal noise. Therefore make sure that they are installed or fastened properly to avoid abnormal noise that can occur after the air conditioning installation is complete.

Tightening torque for tapping screw .....  $1.5 \begin{matrix} +0.5 \\ -0 \end{matrix}$  N·m ( $15 \begin{matrix} +0.5 \\ -0 \end{matrix}$  kgf·cm)

Tightening torque for cross recessed head bolt .....  $3.4 \pm 1.4$  N·m ( $35 \pm 15$  kgf·cm)

- 2. If the hole for a tapping screws is too large, use a tapping screw one-size larger.
- 3. Reinstall each part with particular care so that its clips, guides bosses fit in the specified positions.
- 4. When installing the instrument panel, make sure that wire harness is not pulled, pushed excessively or trapped.

## 3-4 FINAL INSPECTION (SAFETY CHECK)

After installing the air conditioning, check for safety and operation of each section shown below.

(1) Inspection after completion of installation

No.	ITEM	DESCRIPTION	CHECK
1	A/C Parts	Install and fasten properly.	
2	Wiring	Do not pinch harness. Make sure connectors are secure.	
3	Vacuum Hoses	Do not bend excessively, pinch or constrict.	
4	Safety Gaps	Maintain specified or in excess of that specified in the installation manual.	
5	Compressor	There should be no abnormal noise during operation.	

(2) Check for operation of the air conditioning unit

No.	ITEM	DESCRIPTION	CHECK
1	Activation of Magnetic Clutch	ON/OFF	
2	Blower Motor Speed Change	Lo to Hi	
3	Air Outlet Change	Lever Operation	
4	FRS/REC. Change	Lever Operation	
5	Temperature Adjustment	COOL to HOT	
6	Condenser fan	Operation	

(3) Check for operation of each electrical component in the vehicle (To be carried out before and after installation of the air conditioning unit)

ITEM	CHECK		ITEM	CHECK		CHECK ITEM	CHECK	
	Before	After		Before	After		Before	After
Turn Signals			Horn			Clock		
Flashers			Washer			Radio		
Head lights			Wipers			Blower Motor		
Stop lights			Inside lights			Back up lights		
Tail lights			Cigarette lighter					

THE AIR CONDITIONER IS NOW READY FOR USE. BE SURE TO EXPLAIN OPERATION TO THE OWNER.

# 4. A/C AMPLIFIER

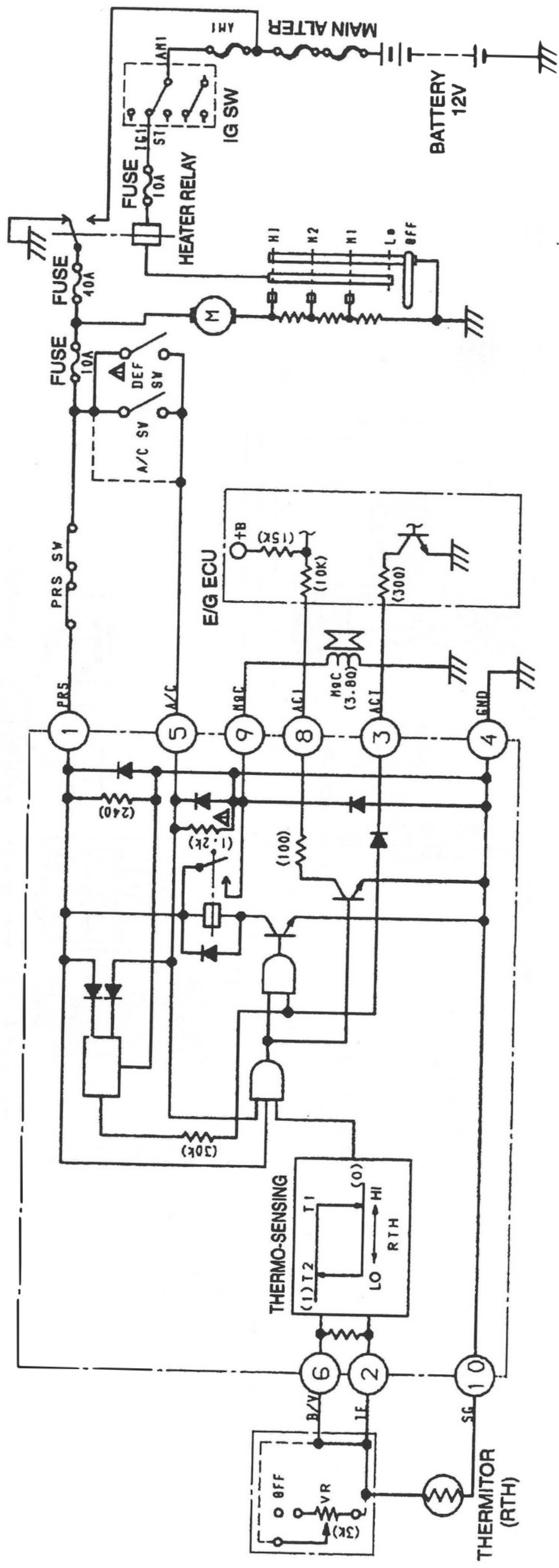

277300-040

# 5. WIRING DIAGRAM

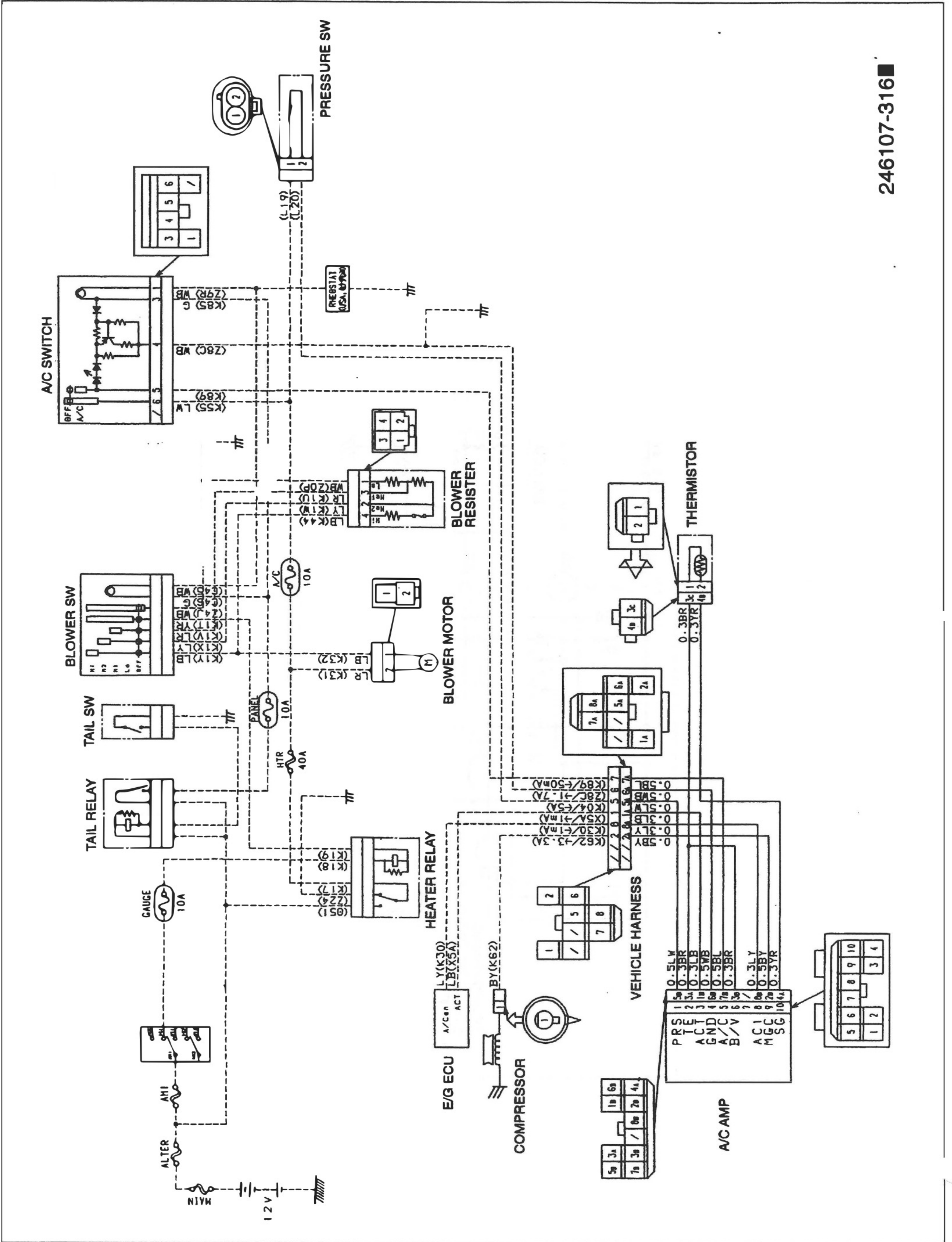

246107-316