

TOYOTA LAND CRUISER

AIR CONDITIONER

FZJ80R

INSTALLATION MANUAL



FOREWORD

This manual has been published to explain how to install the air conditioner into the TOYOTA LANDCRUISER FZJ80R (1FZ-FE E/G).

When installing the air conditioner, installation should be performed as described in this manual.

Improper installation will reduce both the air conditioner and vehicle performance.

TABLE OF CONTENTS

	PAGE
GENERAL INFORMATION	1
1. INSTALLATION	6
1.1 INSTALLATION : PASSENGER COMPARTMENT	6
1.2 INSTALLATION : ENGINE COMPARTMENT	12
2. FINISH	23
3. A/C AMPLIFIER	24
4. WIRING DIAGRAM	25

GENERAL INFORMATION

1. PREPARATIONS BEFORE INSTALLATION

- (1) Prior to installing the air conditioner, make the following inspections for damage or malfunctions.
 - (a) Internal and external trim and bodywork.
 - (b) Engine idling speed.
 - (c) Engine cooling system.
 - (d) All vehicle functions.
(Headlights, indicators, Horn, etc.)

(2) Preparation of Air Conditioner Parts

- (a) Check that the correct kit has been chosen for the installation.
- (b) When unpacking the kit, lay all parts out in order of installation and check for missing or damaged parts.
- (c) When installing the air conditioner, use fender covers and seat covers for protection.

(3) Installation Tools

- (a) Vacuum Pump
- (b) Air Conditioner Service Tools
- (c) Torque Wrench
- (d) Hand service Tools
- (e) Fender covers and seat covers

2. SERVICE PRECAUTIONS

- (1) Disconnect the battery negative cable from the terminal.
- (2) The bolt where specified must be torqued to specification.

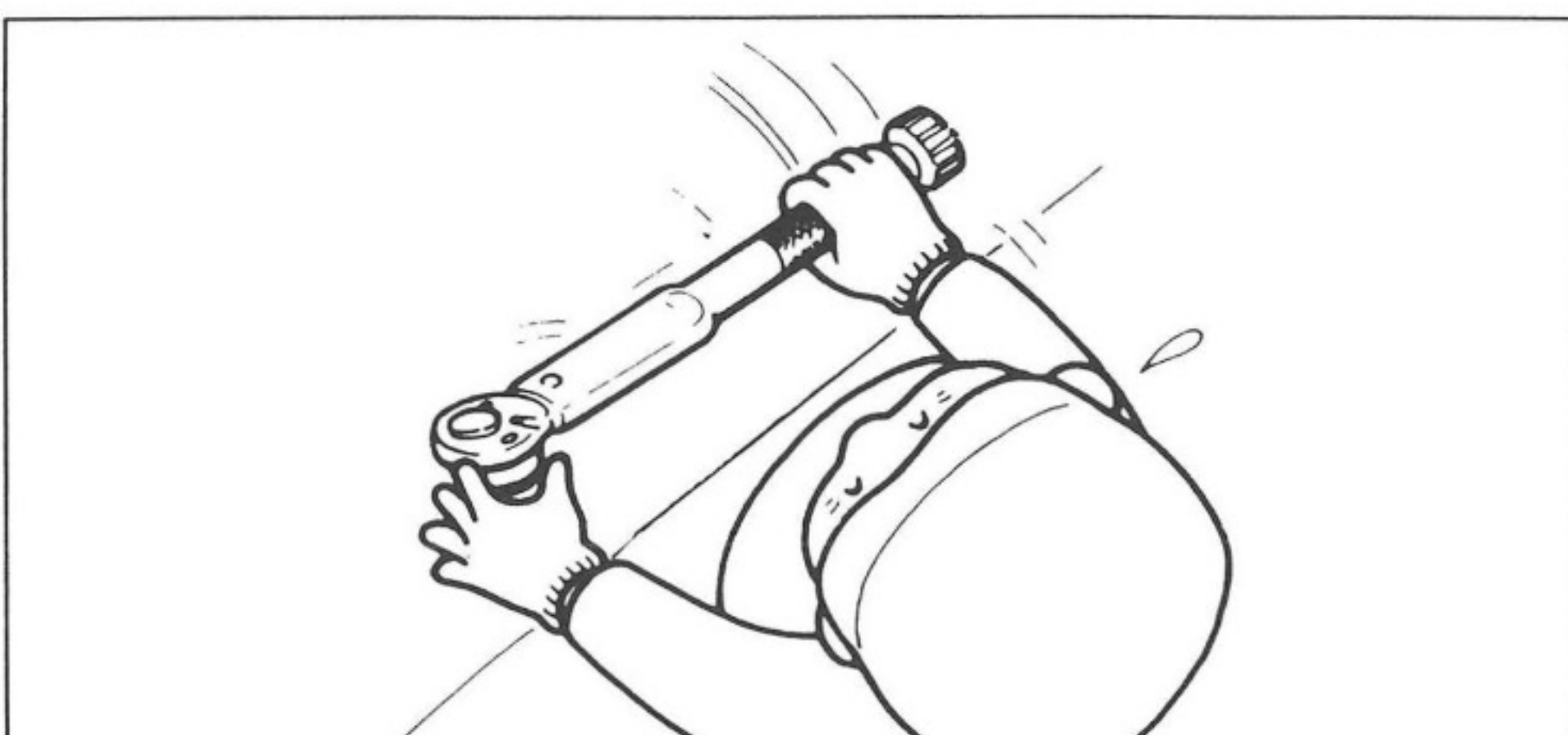
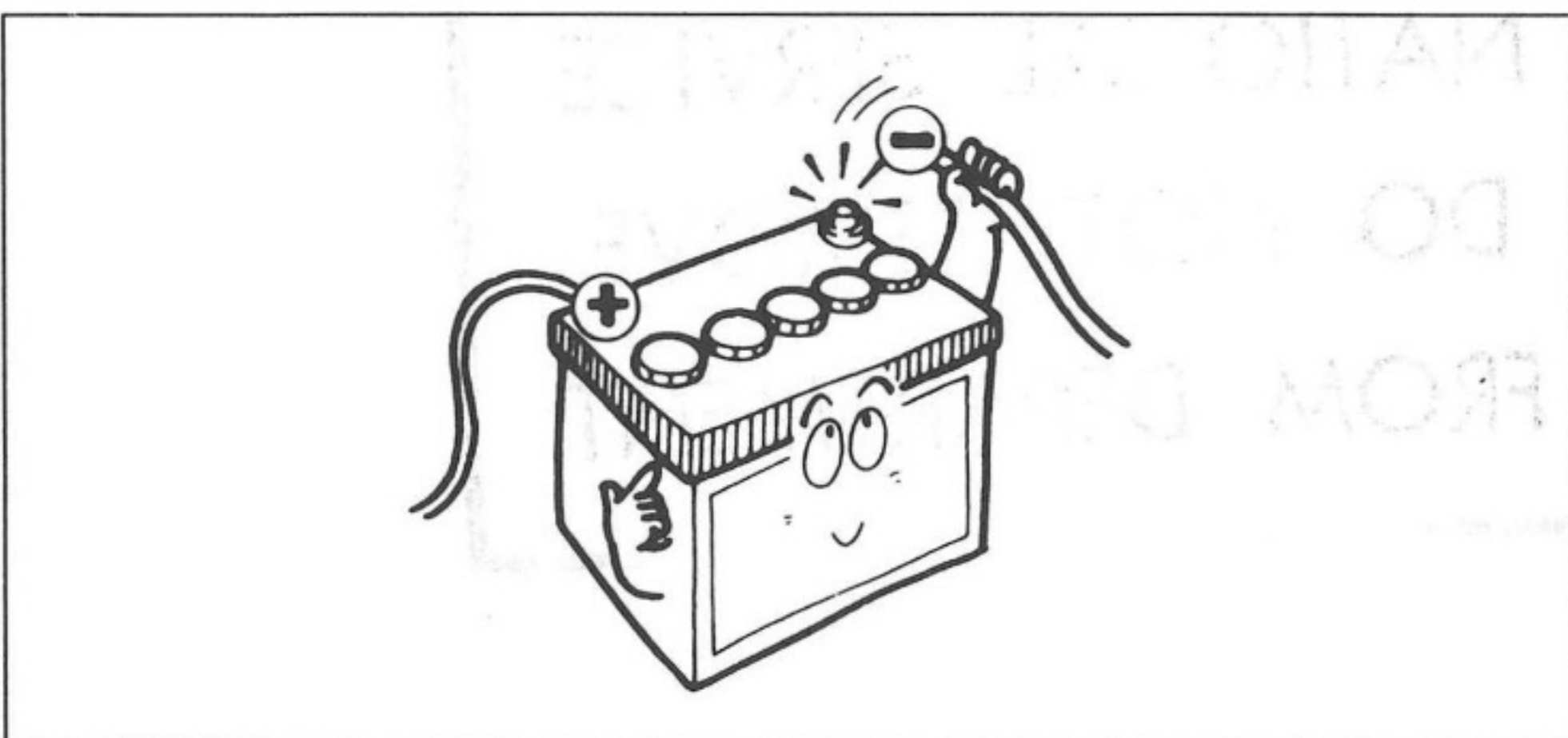

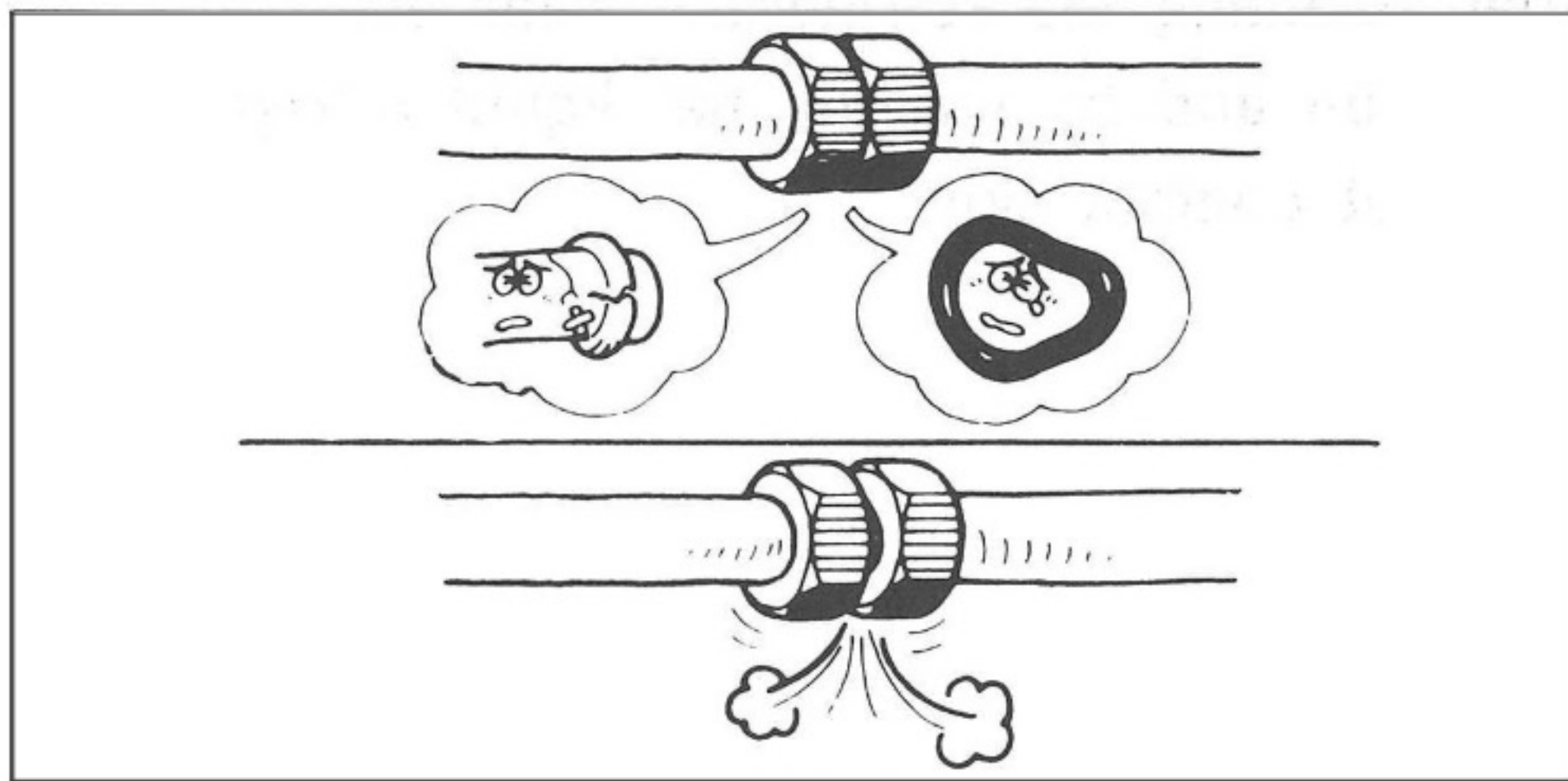
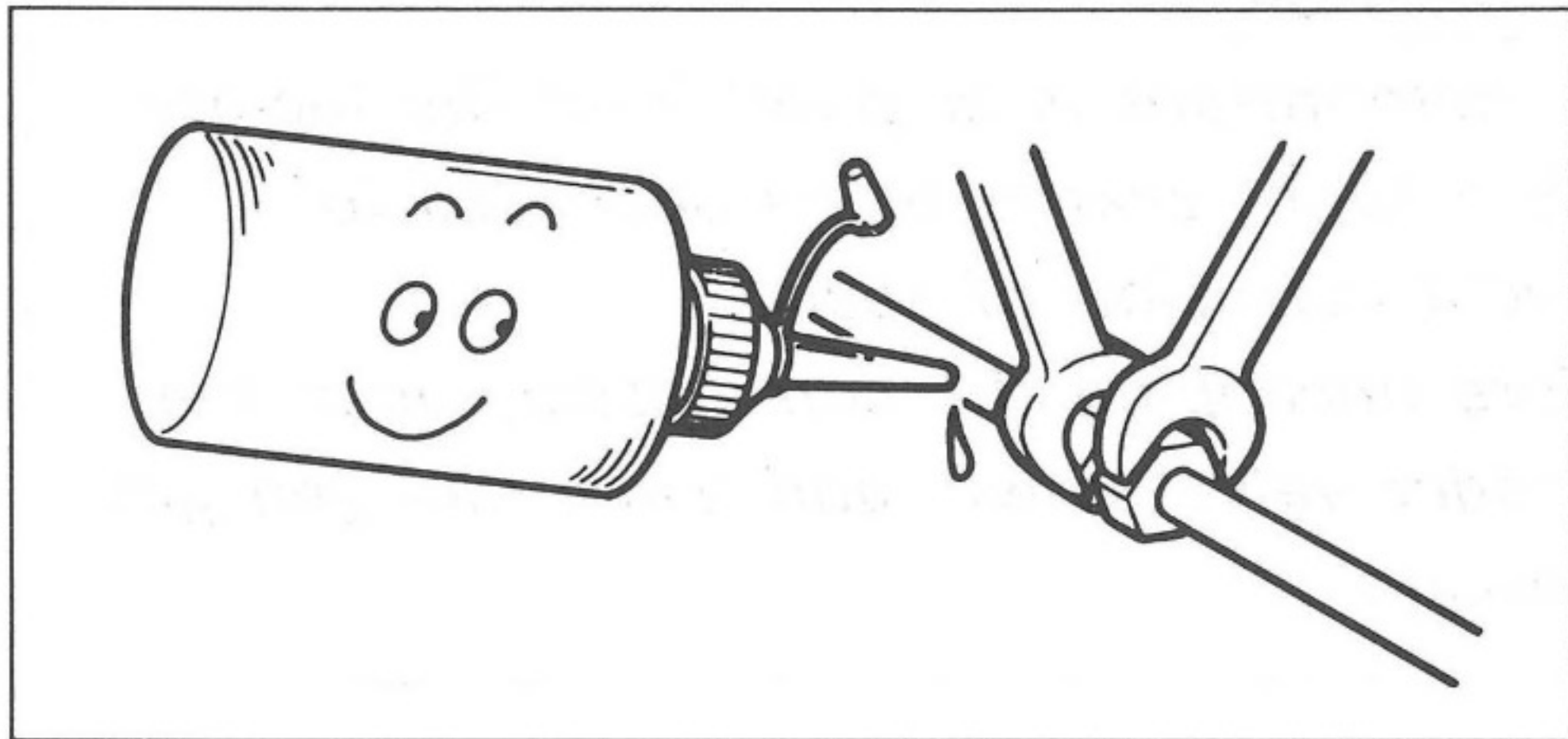
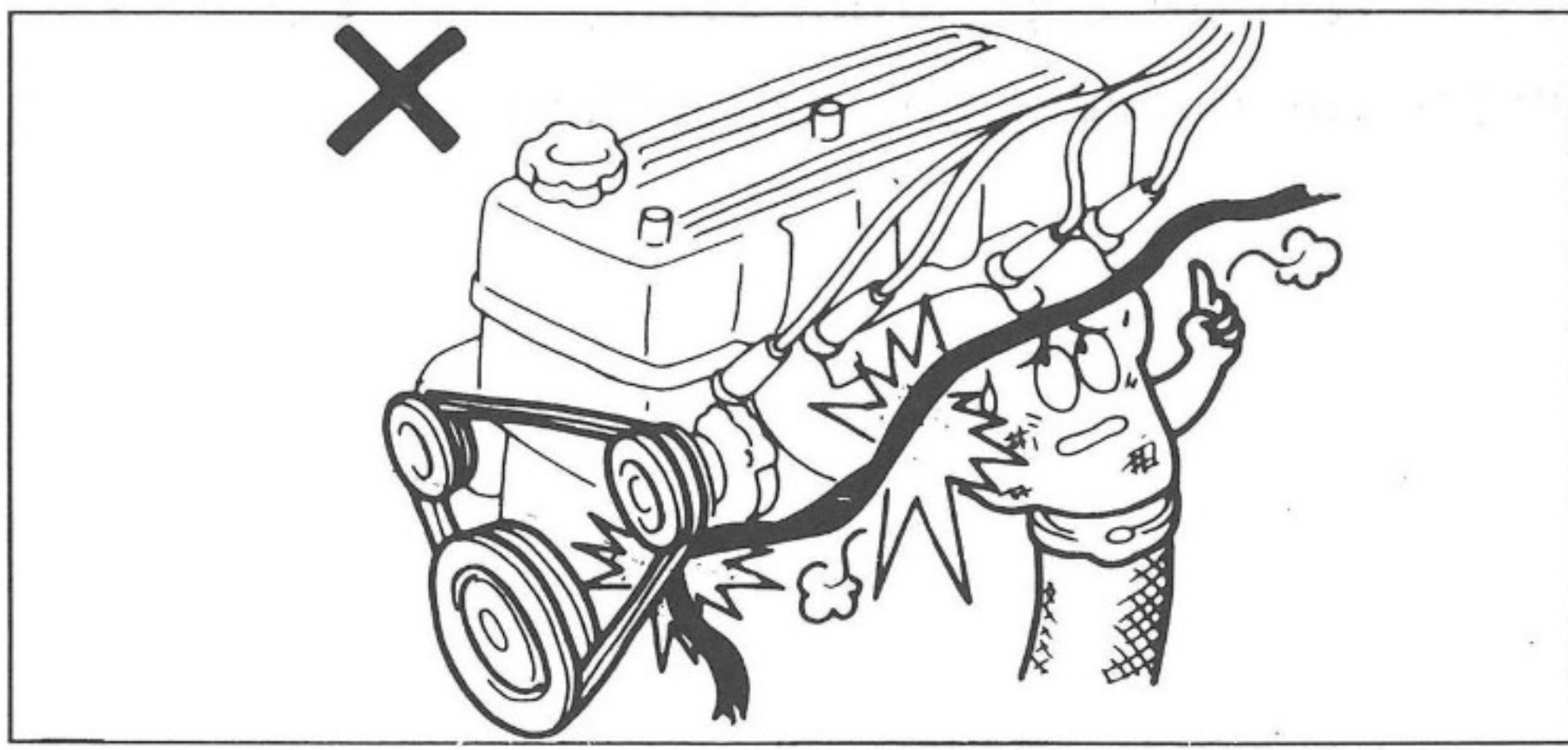

(3) When installing air conditioning lines and A/C harnesses, route properly to avoid interference with surrounding parts.

(4) Before making any hose and tube connections, apply a few drops of compressor oil to the seat of O-ring to avoid refrigerant leakage.

CAUTION

Don't reuse the O-ring. Use new O-ring in making any hose or tube connection.

(5) When tightening or loosening line fittings, use two wrenches to prevent the tubes from twisting.

(6) Tighten coupling nut type fittings or bolted type fittings according to specified torque.

Standard Torque for O-ring Fittings
 <Coupling nut type fitting>

Size of Tube (inch)	Fitting Torque N · m (kgf · cm, ft · lbf)
0.31	13.7 (140, 10.1)
0.50	22.5 (230, 16.6)
0.62	32.3 (330, 23.9)

<Block type fittings>

Block type fittings	Bolt or Nut Size	Fitting Torque N·m (kgf·cm, ft·lbf)
Compressor Side	M8	24.5 (250, 18.1)
	M6	9.8 (100, 7.2)
Condenser Side	M8	12.7 (130, 9.4)
	M6	9.8 (100, 7.2)
Receiver Side	M6	5.4 (55, 4.0)
Others	M8	12.7 (130, 9.4)
	M6	9.8 (100, 7.2)

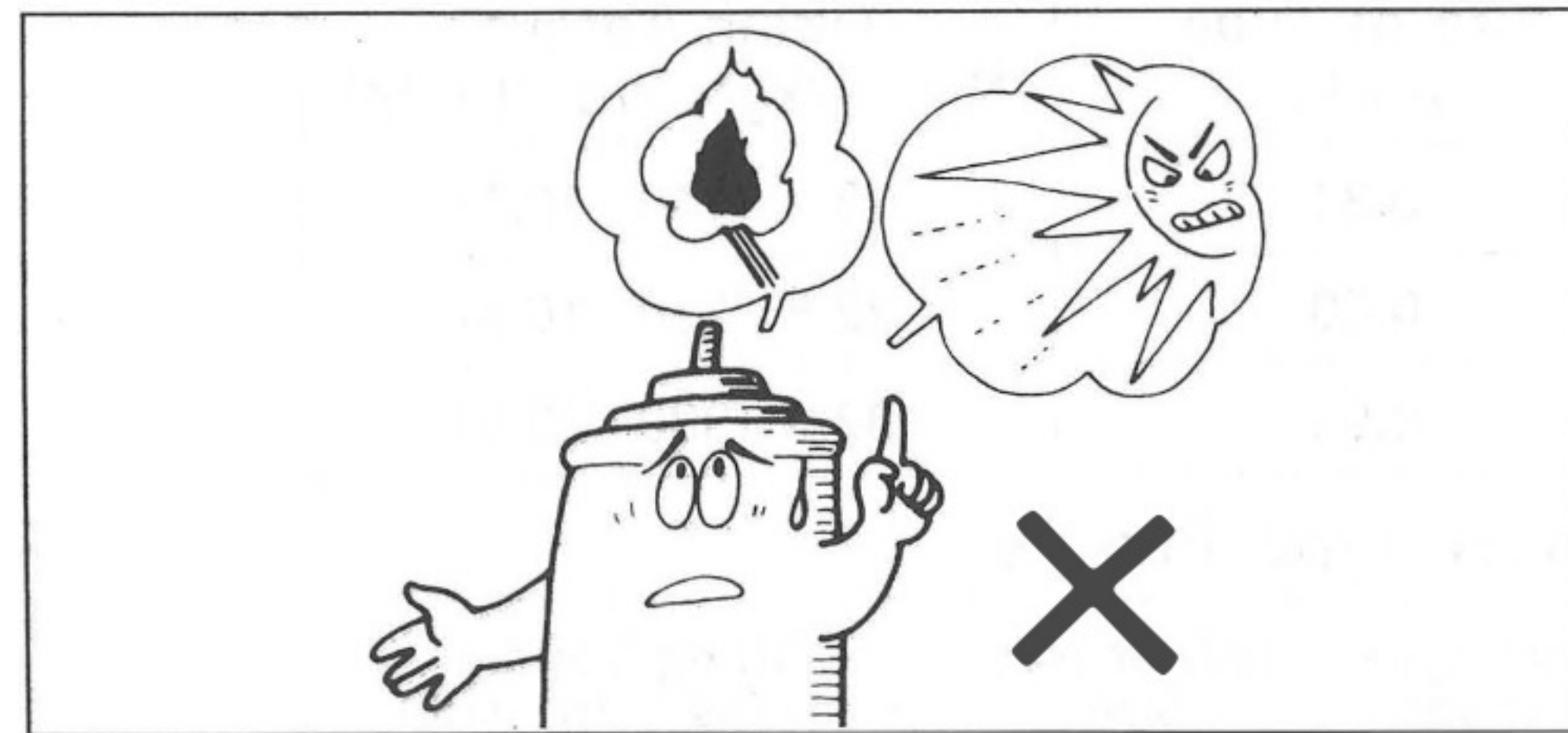
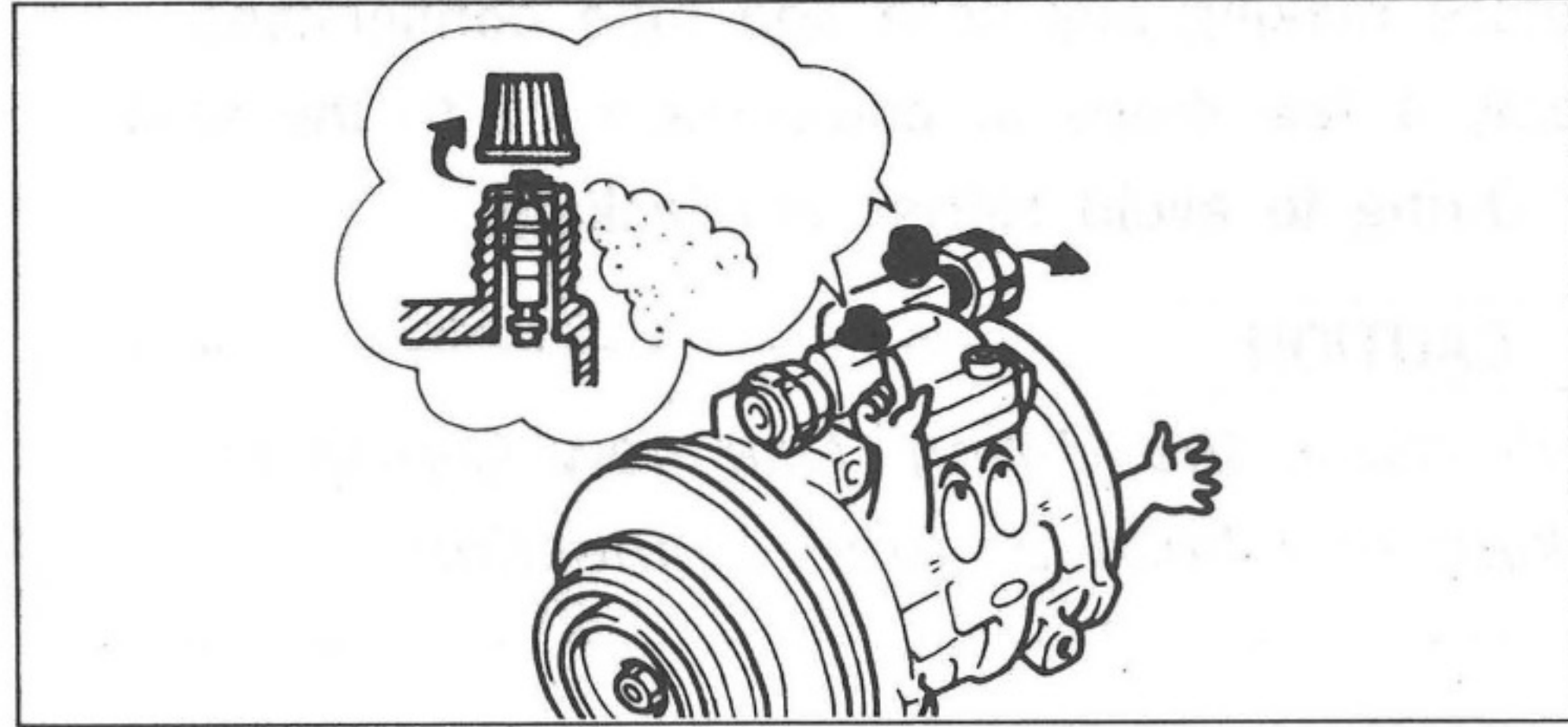
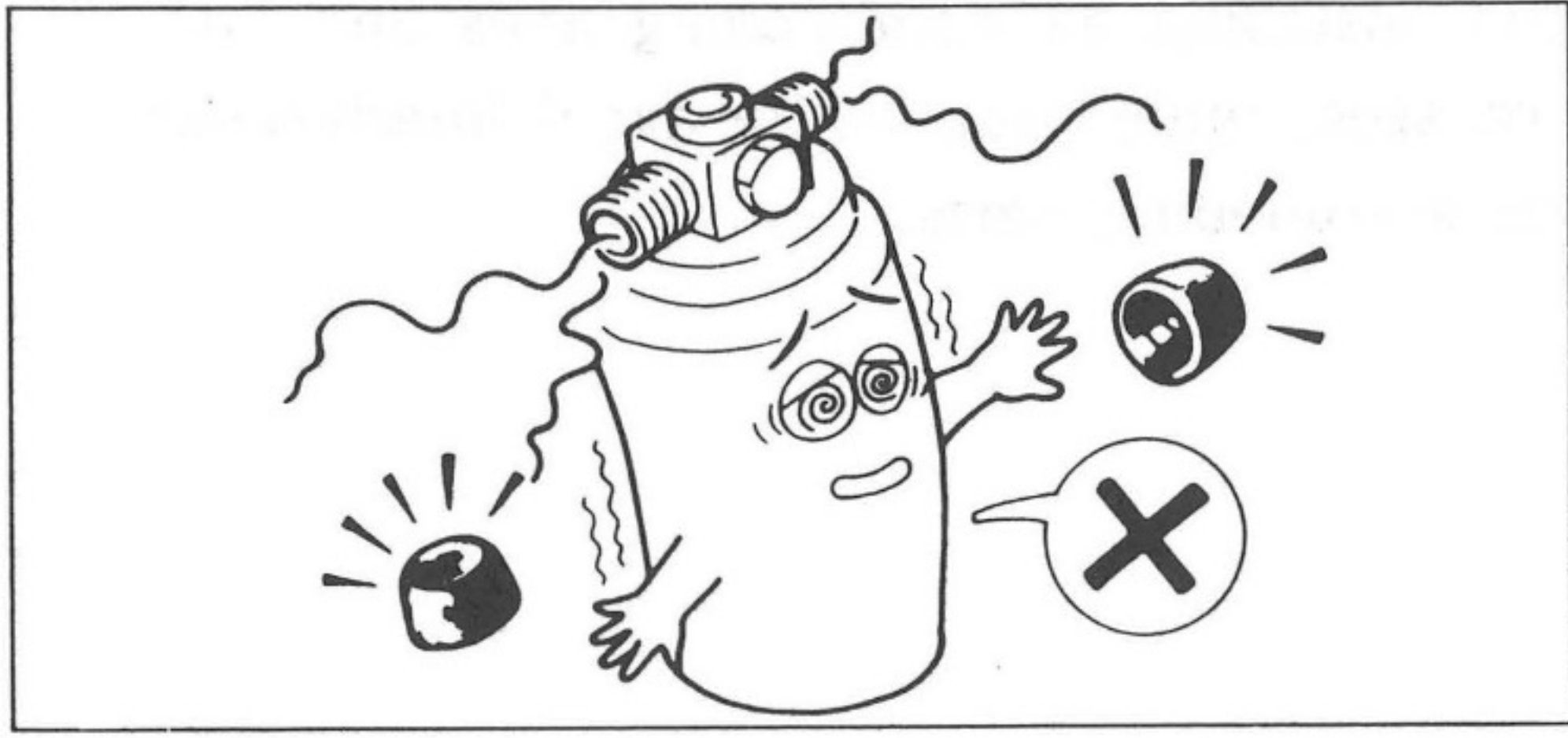

(7) Do not remove caps from fittings until each component is ready for connection.

CAUTION

The compressor is shipped from the factory with a slight charge of nitrogen gas to prevent corrosion of seals. Before uncapping the compressor, push the schrader valve slowly and allow nitrogen gas to escape.

(8) When handling the refrigerant, wear eye protection and be careful that liquid refrigerant does not contact skin.

(9) Keep the refrigerant container (service drum) below 40°C (100°F).

3. WHEN INSTALLING

(1) All instructions are given from the driver's point of view.

(2) Figures in parenthesis indicate diameter and length of bolt stem.

Example:

(a) BOLT (M6 × ℓ 16) means a hex. head bolt which has 6mm thread diameter and 16mm stem.

(b) SCREW or TAPPING SCREW (ϕ 6 × ℓ 16) means a round head screw which has a 6mm thread diameter and a 16mm stem.

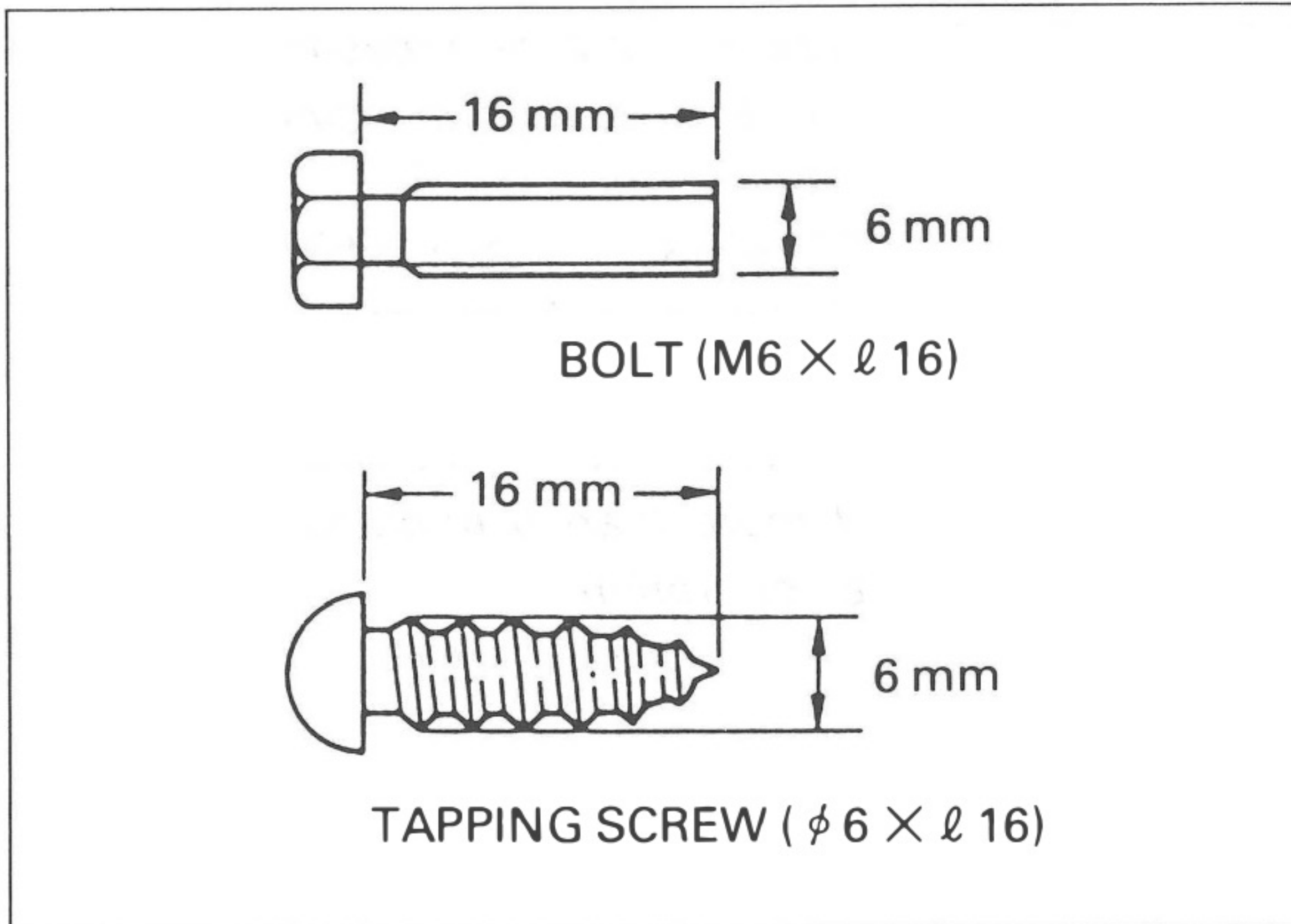

(3) Standard tightening torque

N·m <kgf·cm> (ft·lbf)

Dia × Pitch	Bolt Intensity	Tightening Torque		
M6 × 1.0	4T	5.0	<55>	(4.0)
M8 × 1.25		12.5	<130>	(9.4)
M10 × 1.25		26.0	<260>	(18.8)
M12 × 1.25		47.0	<480>	(34.8)
M6 × 1.0	6T	8.0	<80>	(5.8)
M8 × 1.25		19.0	<195>	(14.1)
M10 × 1.25		39.0	<400>	(29.0)
M12 × 1.25		71.0	<730>	(52.8)
M6 × 1.0	8T	29.0	<300>	(21.7)
M8 × 1.25		61.0	<620>	(44.9)
M10 × 1.25		110.0	<1100>	(79.6)
M12 × 1.25				

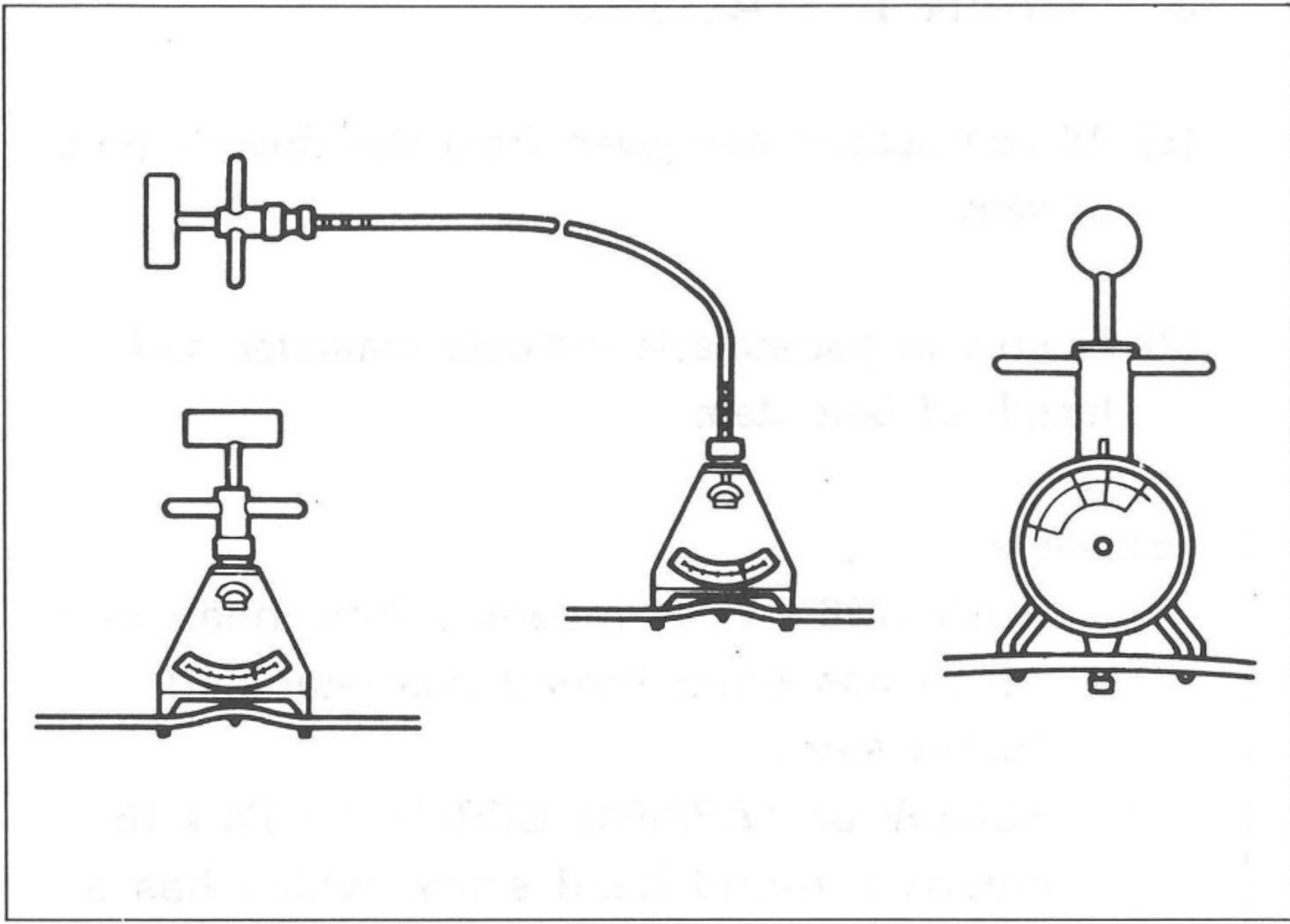

(4) After installing the drive belt, check the belt tension using belt tension gauge NIPPONDENSO BTG-20 or BURROUGHS BT-33-73F.

NOTE

- 1) *The belt tension may be measured between any two pulleys in using belt tension gauge.*
- 2) *“New belt” refers to a belt which has been used less than 5 minutes on an air conditioner operation.
“Used belt” refers to a belt which has been used more than 5 minutes on an air conditioner operation.*

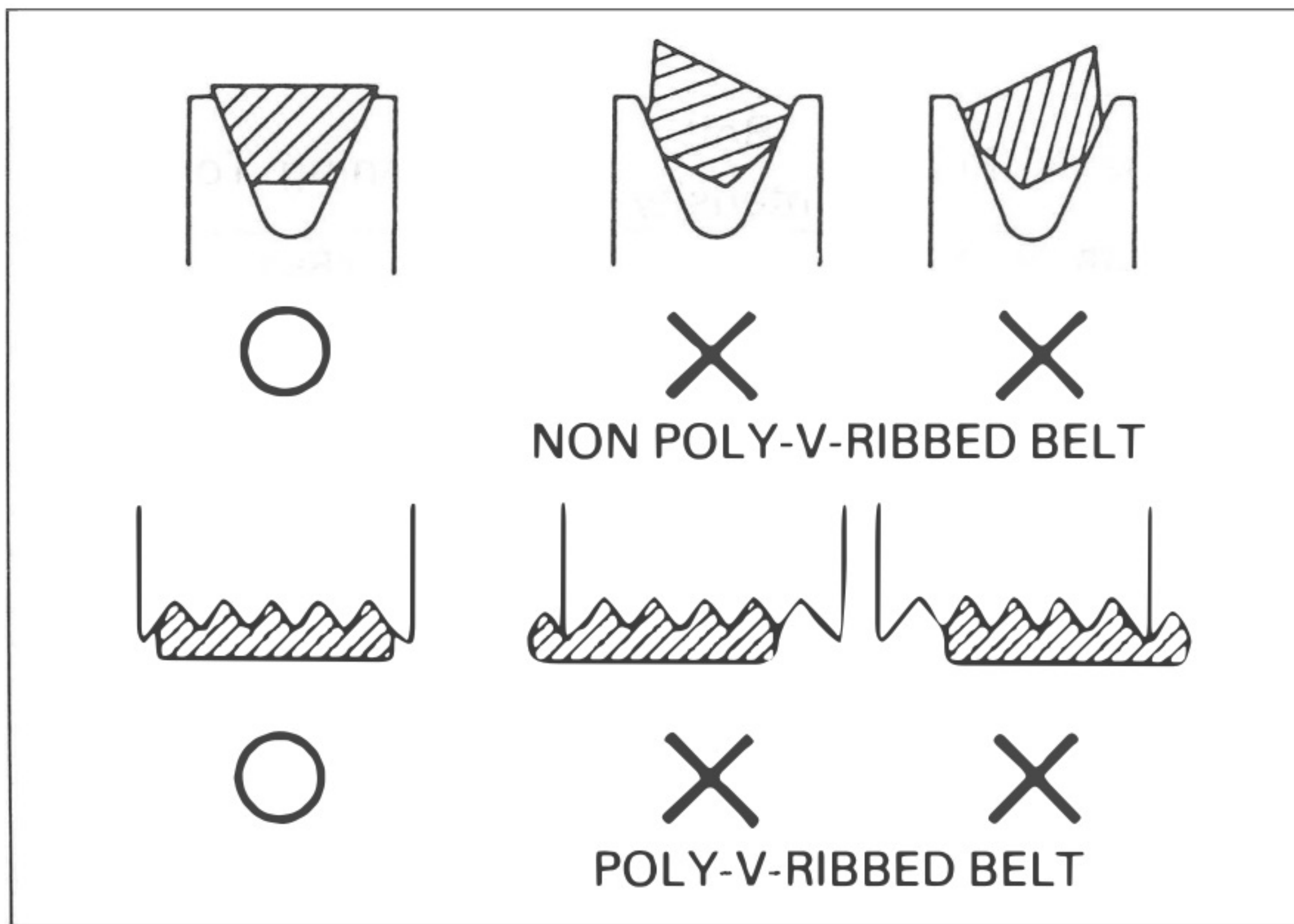

CAUTION

- 1) *The drive belt requires accurate tension adjustment; weak tension is likely to cause belt whine, while excessive tension may result in damage to accessory bearing or to idle pulley bracket.*
- 2) *After installing the drive belt, check that it fits properly in the grooves.*

1. INSTALLATION

CAUTION

Remove the battery negative terminal.

1.1 INSTALLATION : PASSENGER COMPARTMENT

- ※ Use parts container for storage of temporarily removed parts.
- ※ Ensure seat / floor protectors are in position.

(1) REMOVAL OF PARTS

(a) Glove box

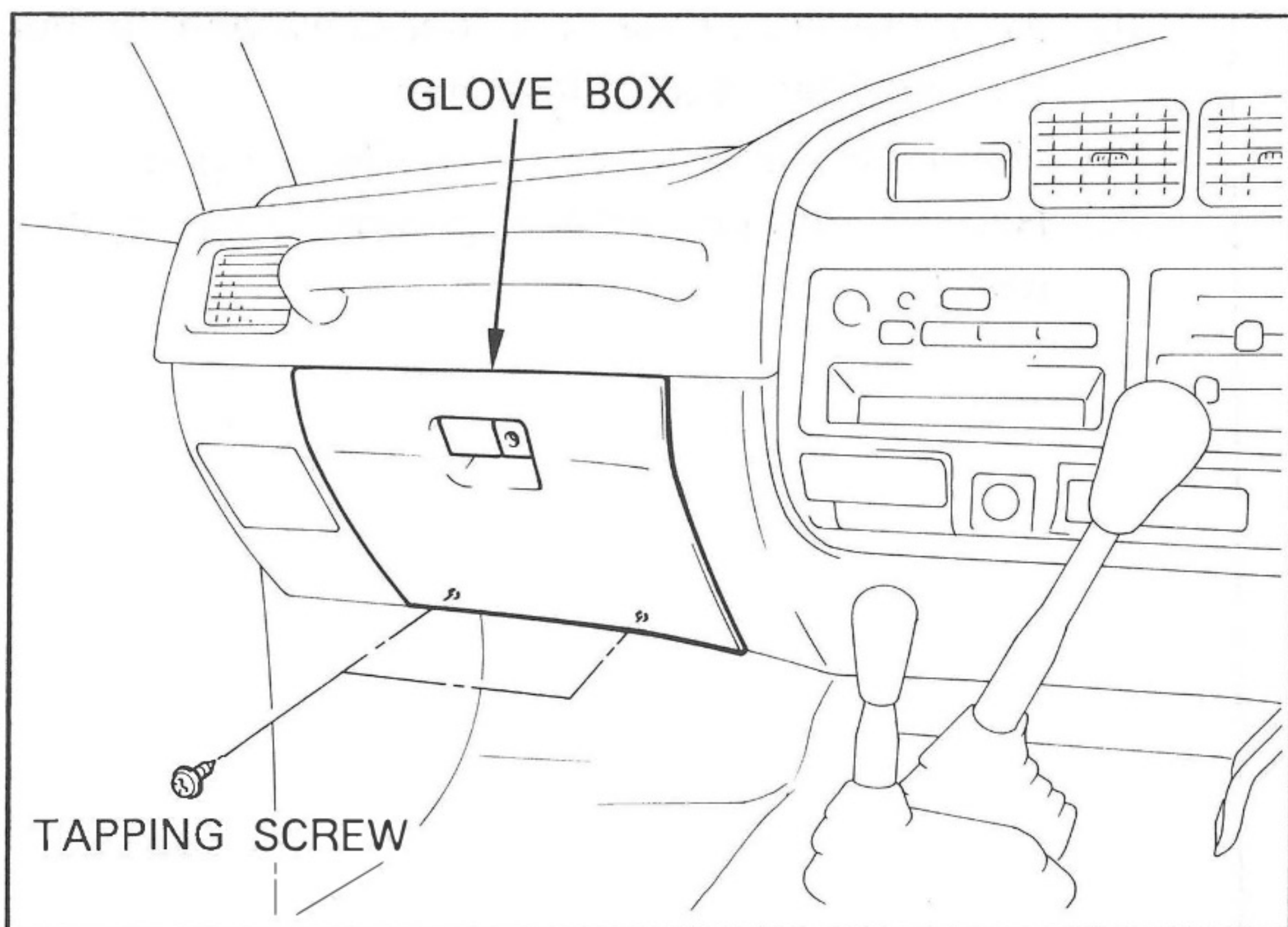

Fig. 1

(b) Reinforcement

CAUTION

Ensure that the tapping screw on the far right hand side is removed.

(c) Blower resistor

NOTE

Keep two tapping screws for the blower resistor.

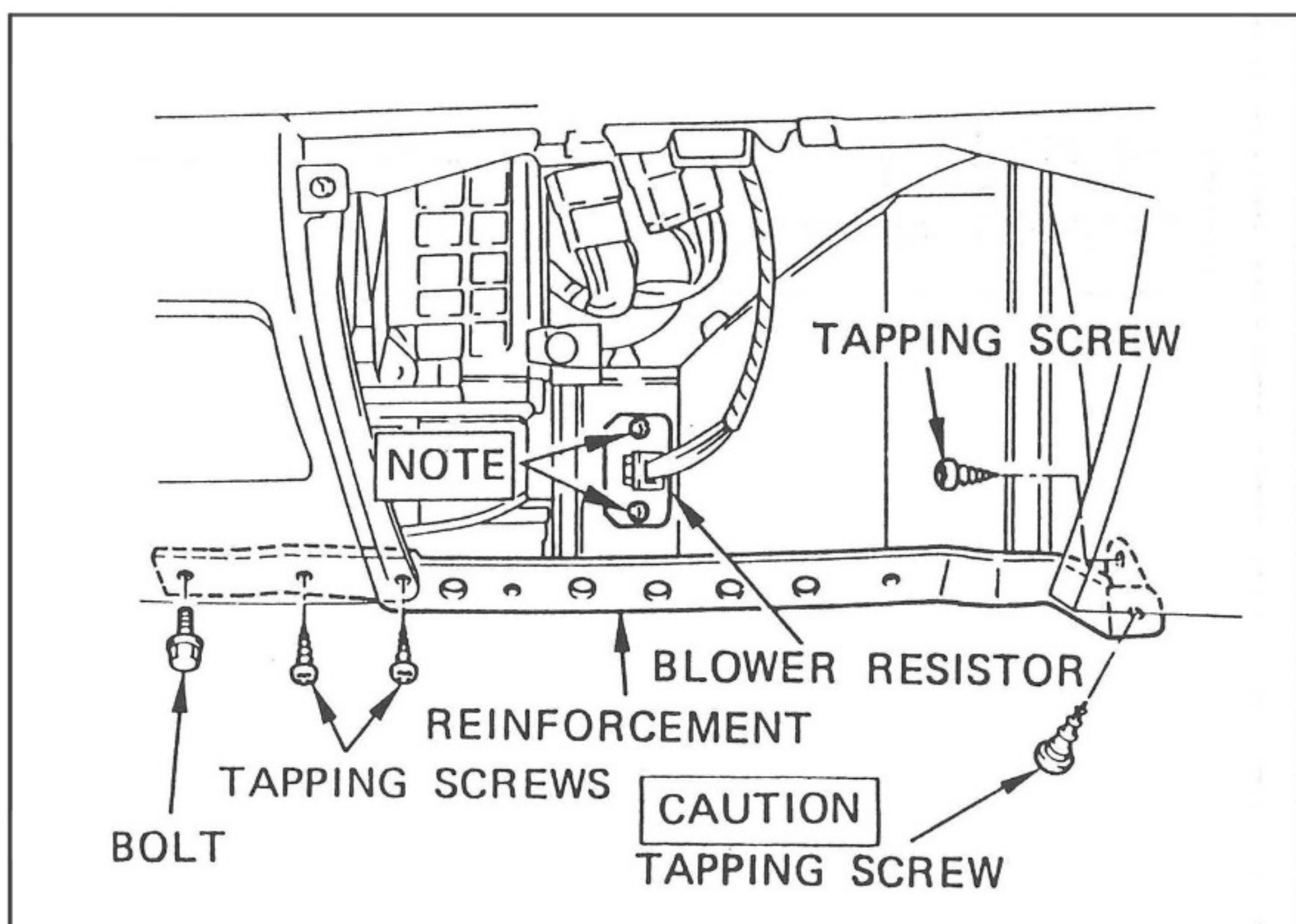

Fig. 2

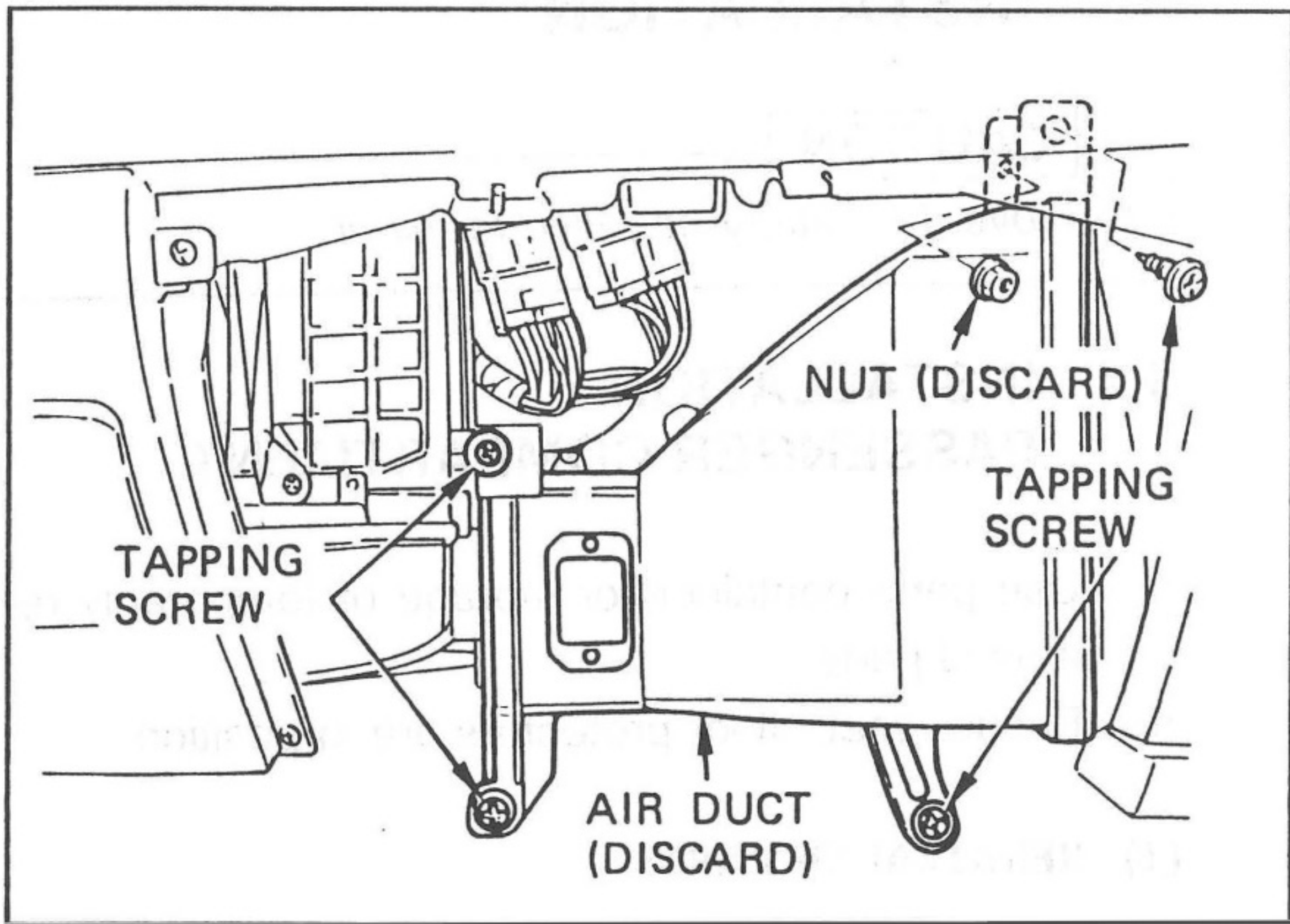

Fig. 3

(d) Air duct Discard

NOTE

Keep four original tapping screws.

(e) Nut Discard

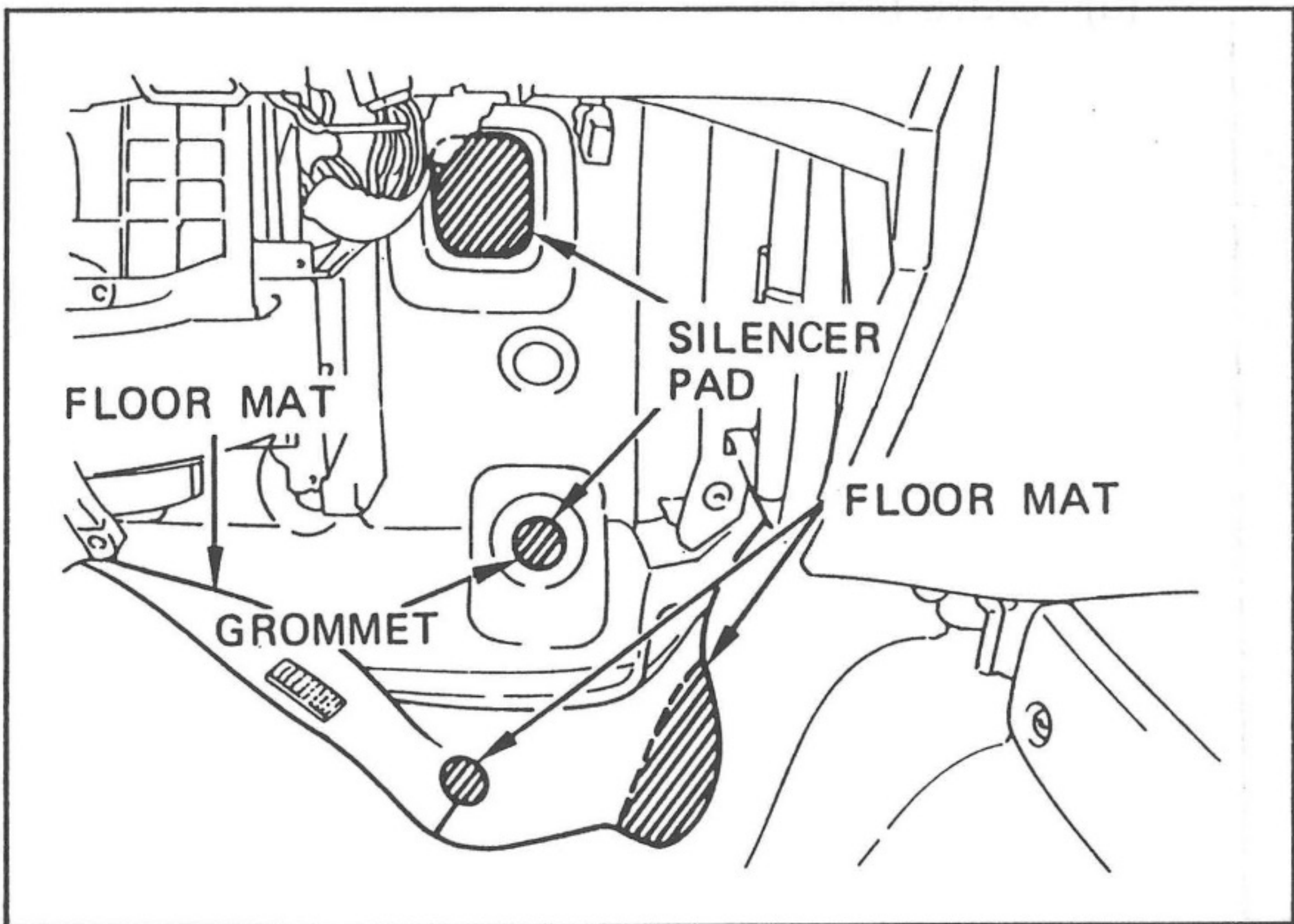

Fig. 4

(f) Temporarily pull the floor mat down and cut out 2 shaded areas from floor mat.

(g) Cut out 2 shaded areas from silencer pad.

(h) Remove and discard the grommet from the fire wall.

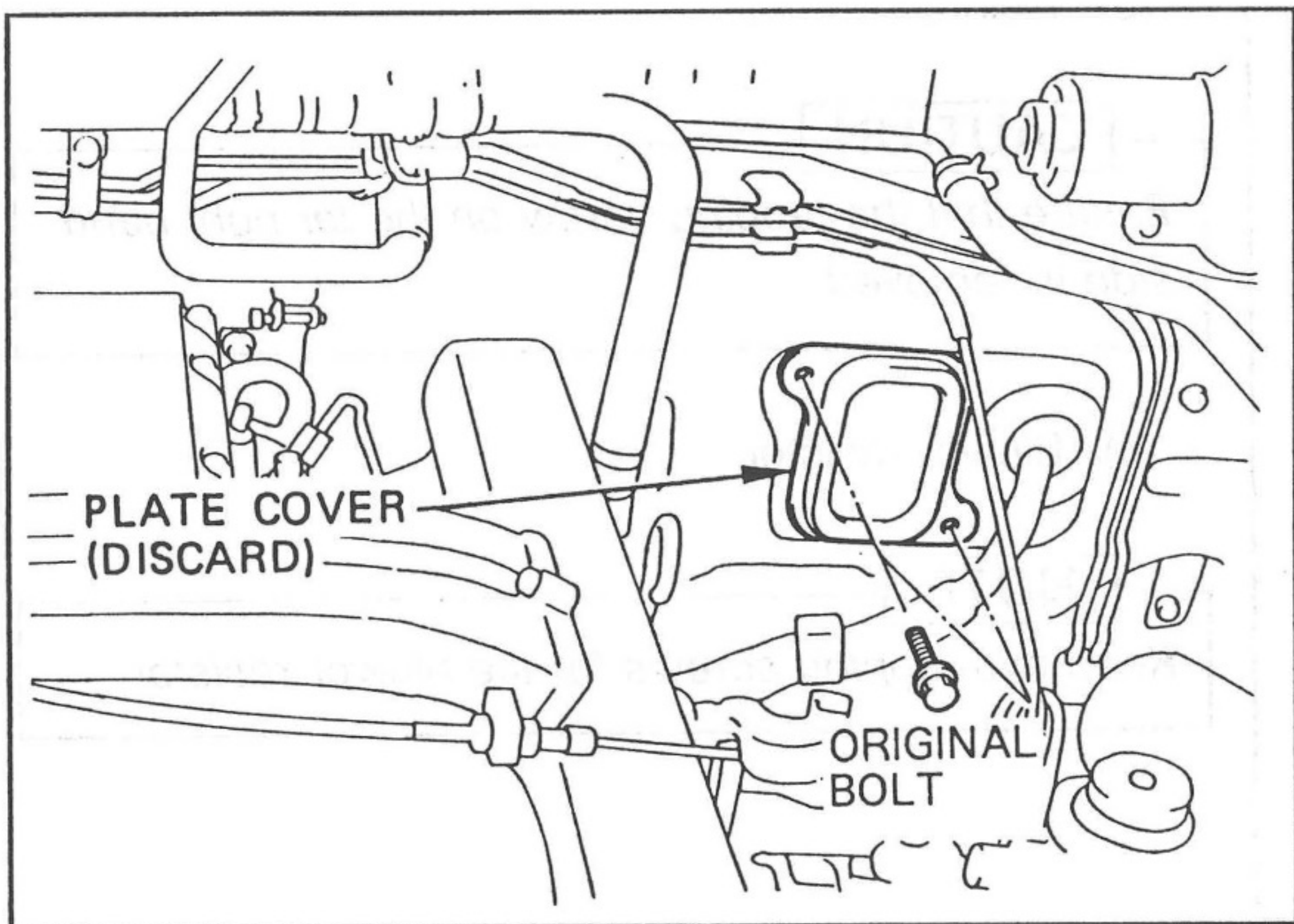

Fig. 5

(i) Plate cover Discard

NOTE

Keep two original bolts.

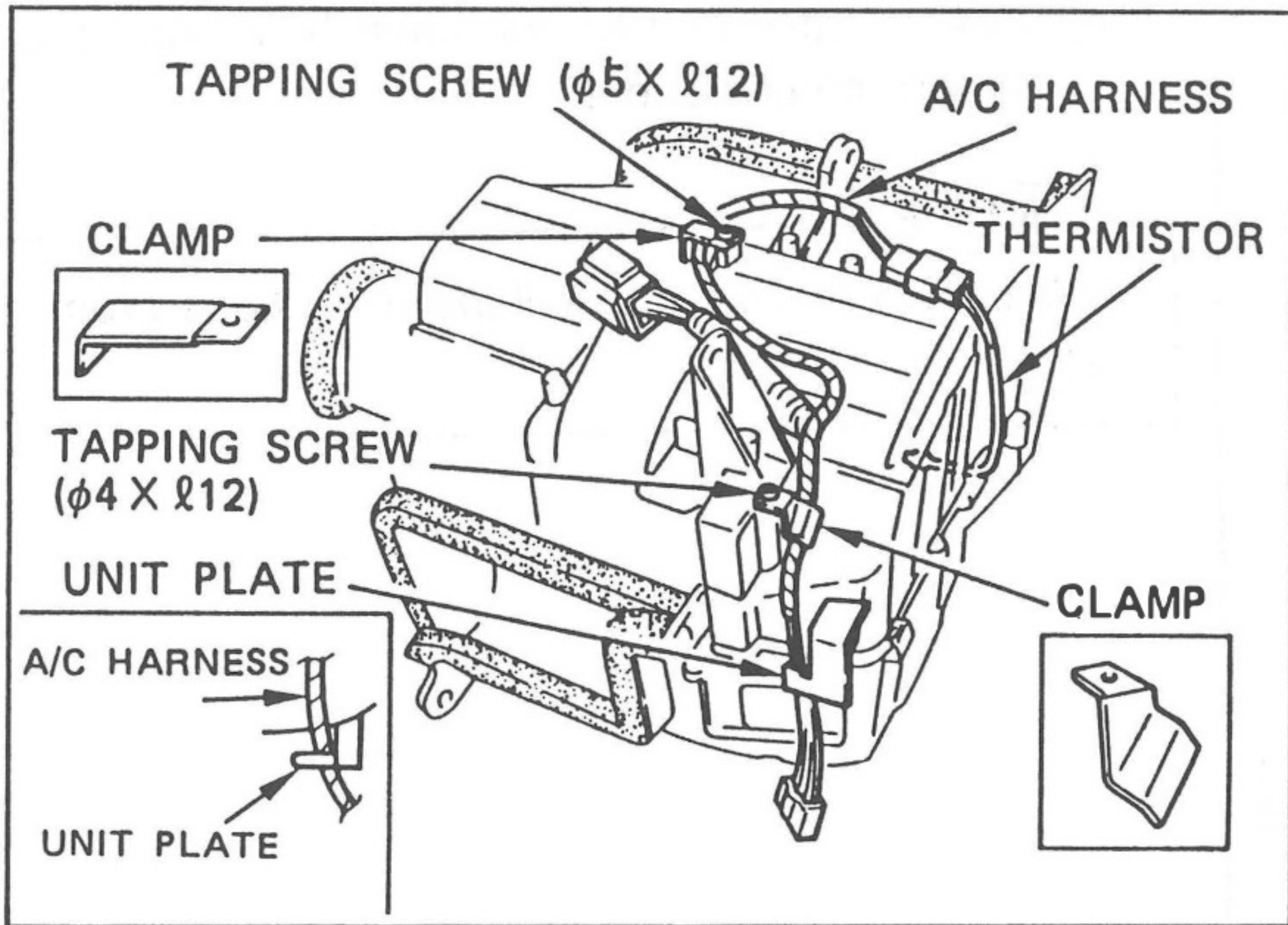

Fig. 6

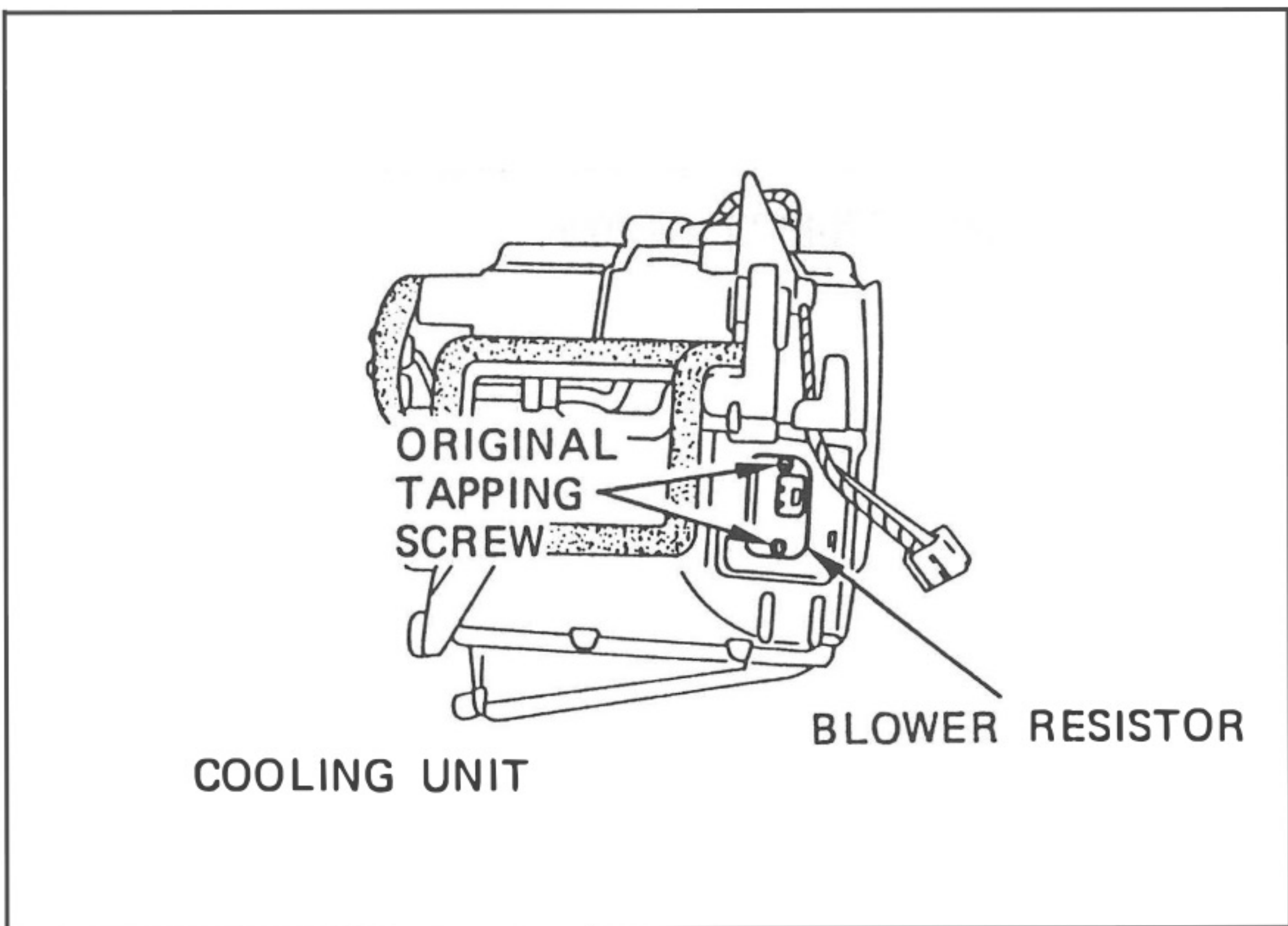

Fig. 7

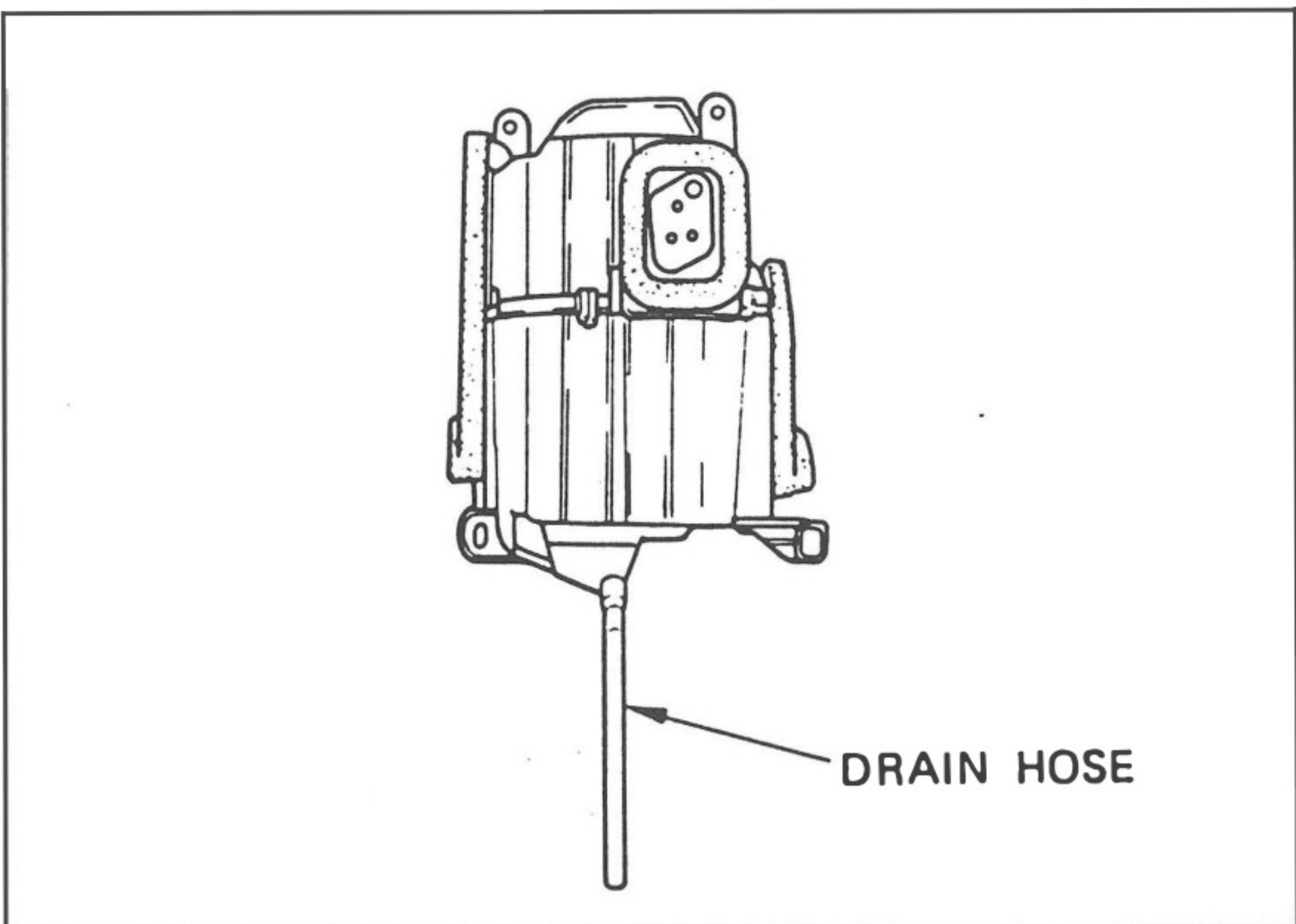

Fig. 8

(2) COOLING UNIT

- (a) Install and secure the A/C harness to the cooling unit using two clamps and two tapping screws.

NOTE

Secure the A/C harness using the unit plate as shown.

- (b) Connect the 2-P connector of the A/C harness to the thermistor.

- (c) Install the original blower resistor to the cooling unit using two original tapping screws.

- (d) Install the drain hose to the cooling unit.

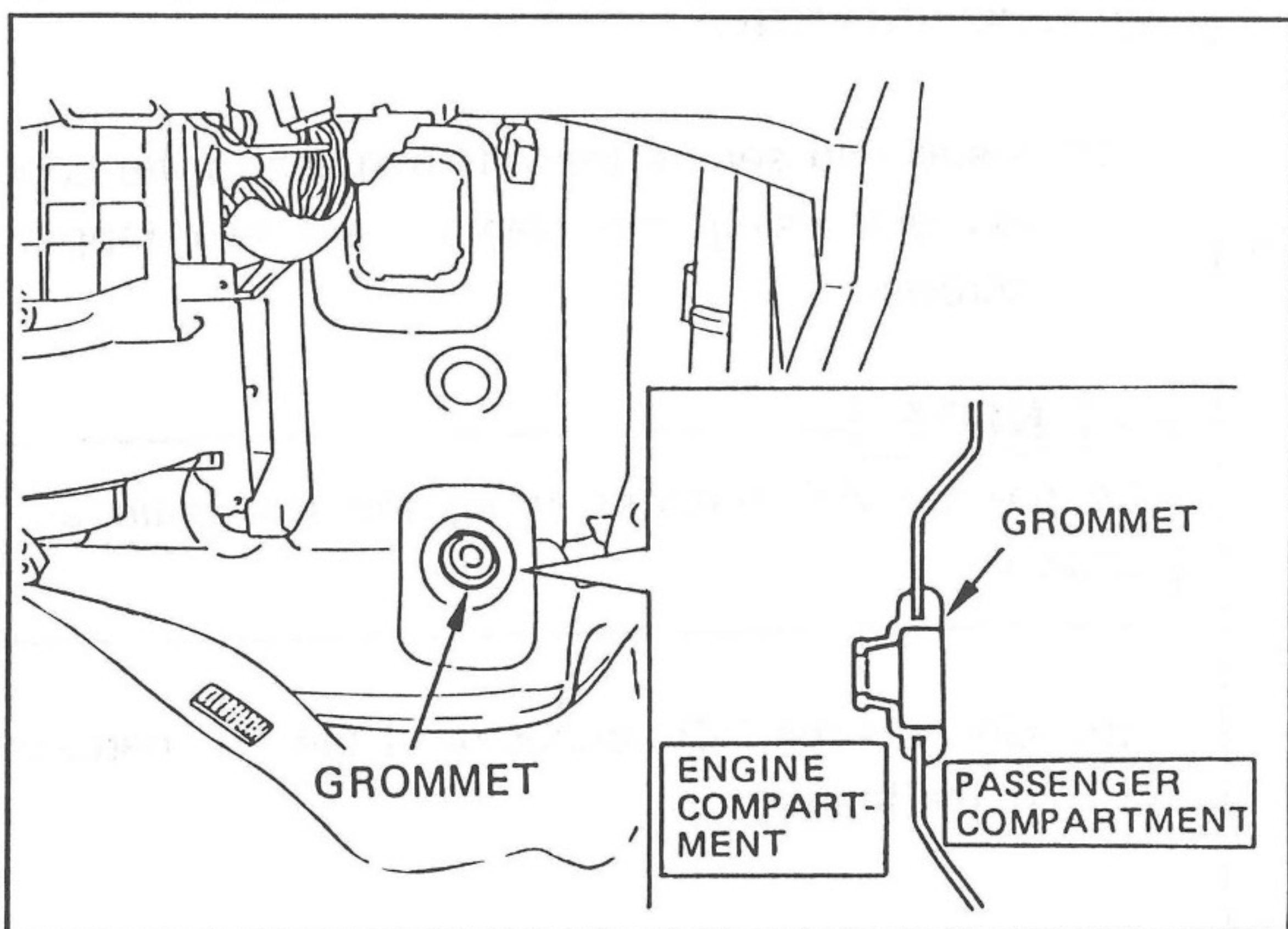

Fig. 9

- (e) Install a grommet for the drain hose from passenger compartment.

NOTE

Lift the silencer pad to install the drain hose grommet.

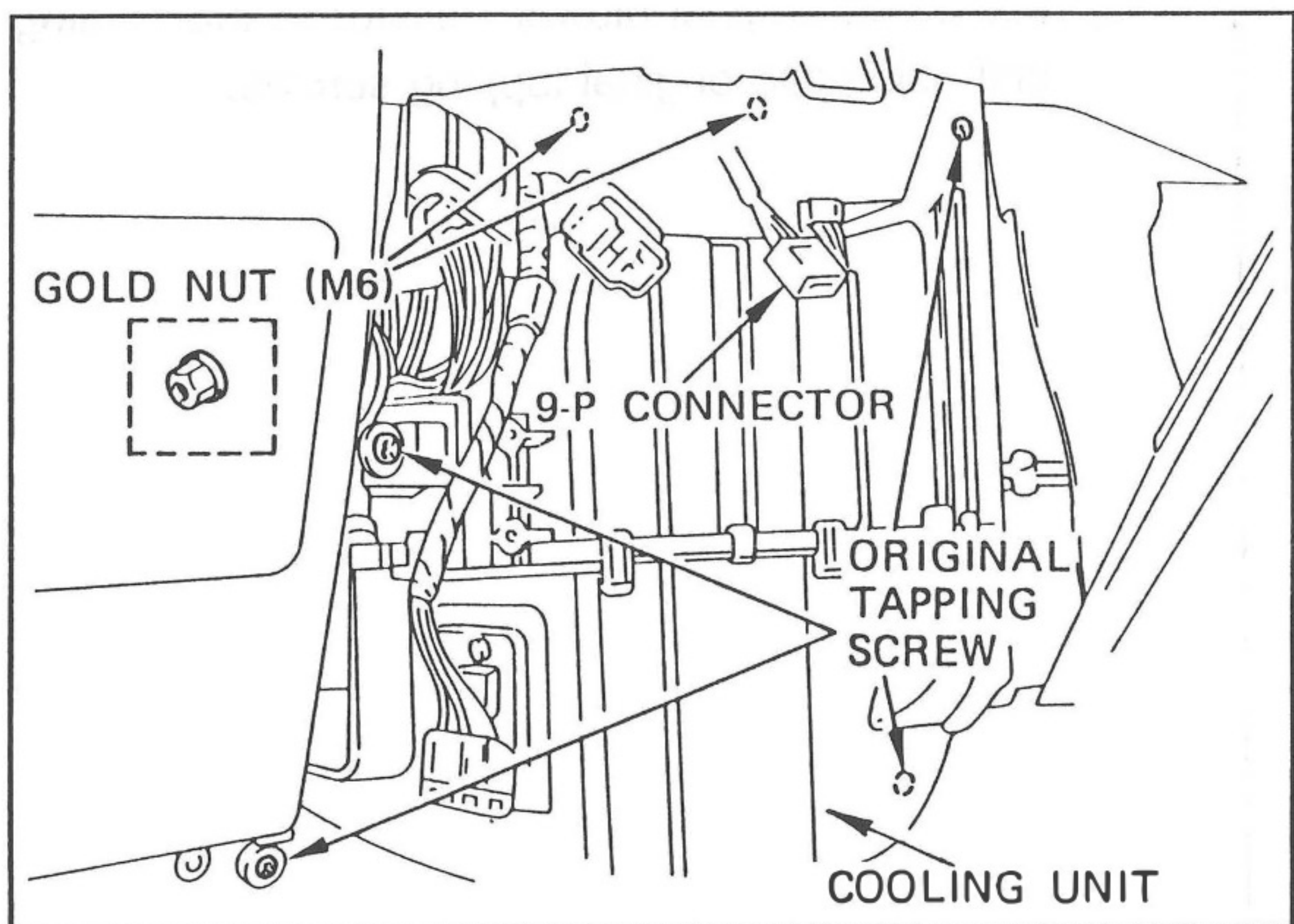

Fig. 10

- (f) Untapped the 9-P connector from the vehicle harness, before to installing the cooling unit.
 (g) Install the cooling unit using two nuts and four original tapping screws.

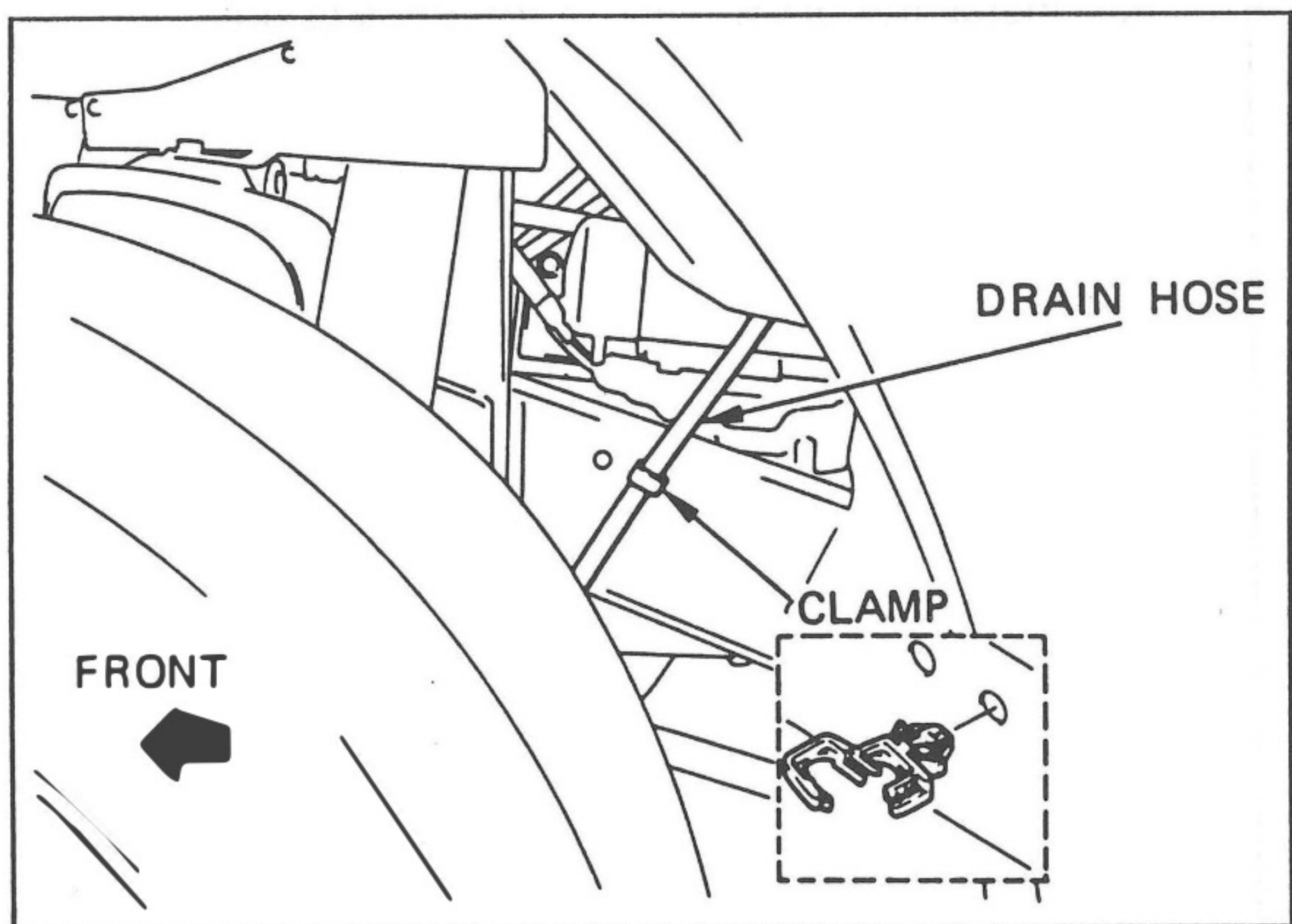

Fig. 11

- (h) Fasten the drain hose on the frame using a clamp.

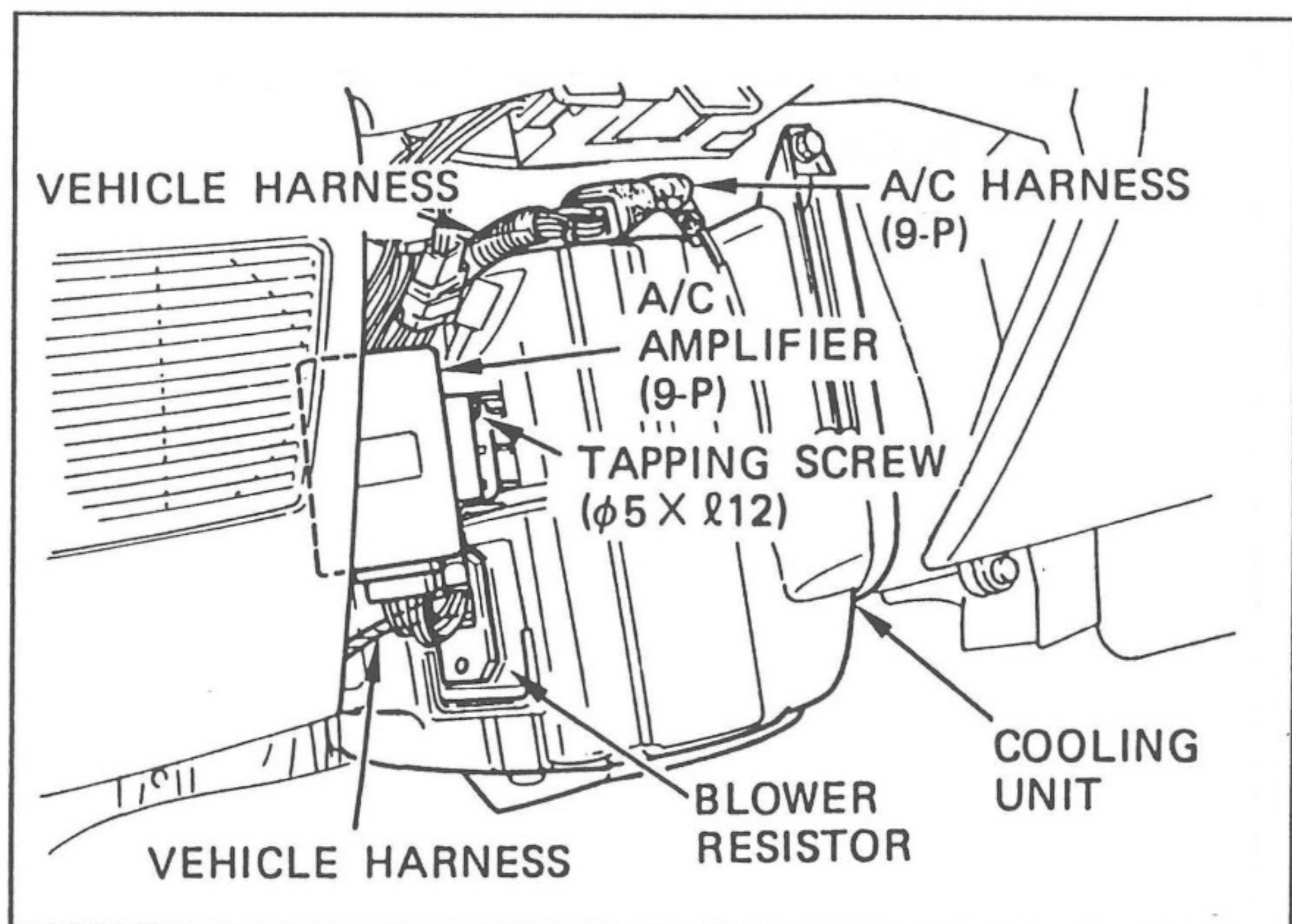

Fig. 12

- (i) Install the A/C amplifier to the cooling unit using a tapping screw.
- (j) Connect the vehicle harness to the blower resistor.
- (k) Connect the A/C harness to the vehicle harness (9-P) and A/C amplifier (9-P).

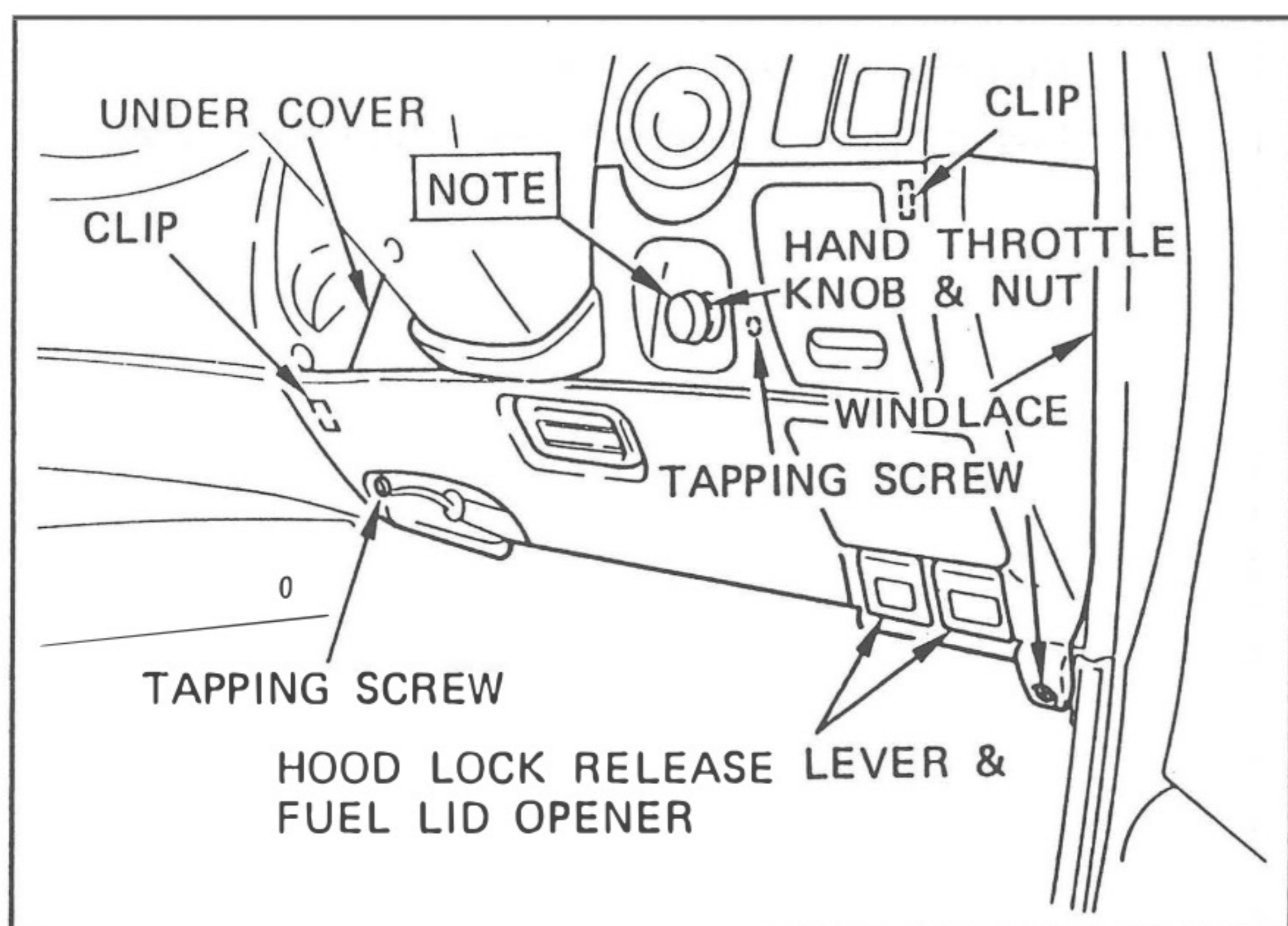

Fig. 13

(3) SIDE AIR DUCT

- (a) Temporarily remove the hand throttle knob and nut.

NOTE

To remove the hand throttle knob, depress the lock pin in the knob and pull it.

- (b) Temporarily remove the windlace and the under cover with the the hood lock release lever & fuel lid opener.

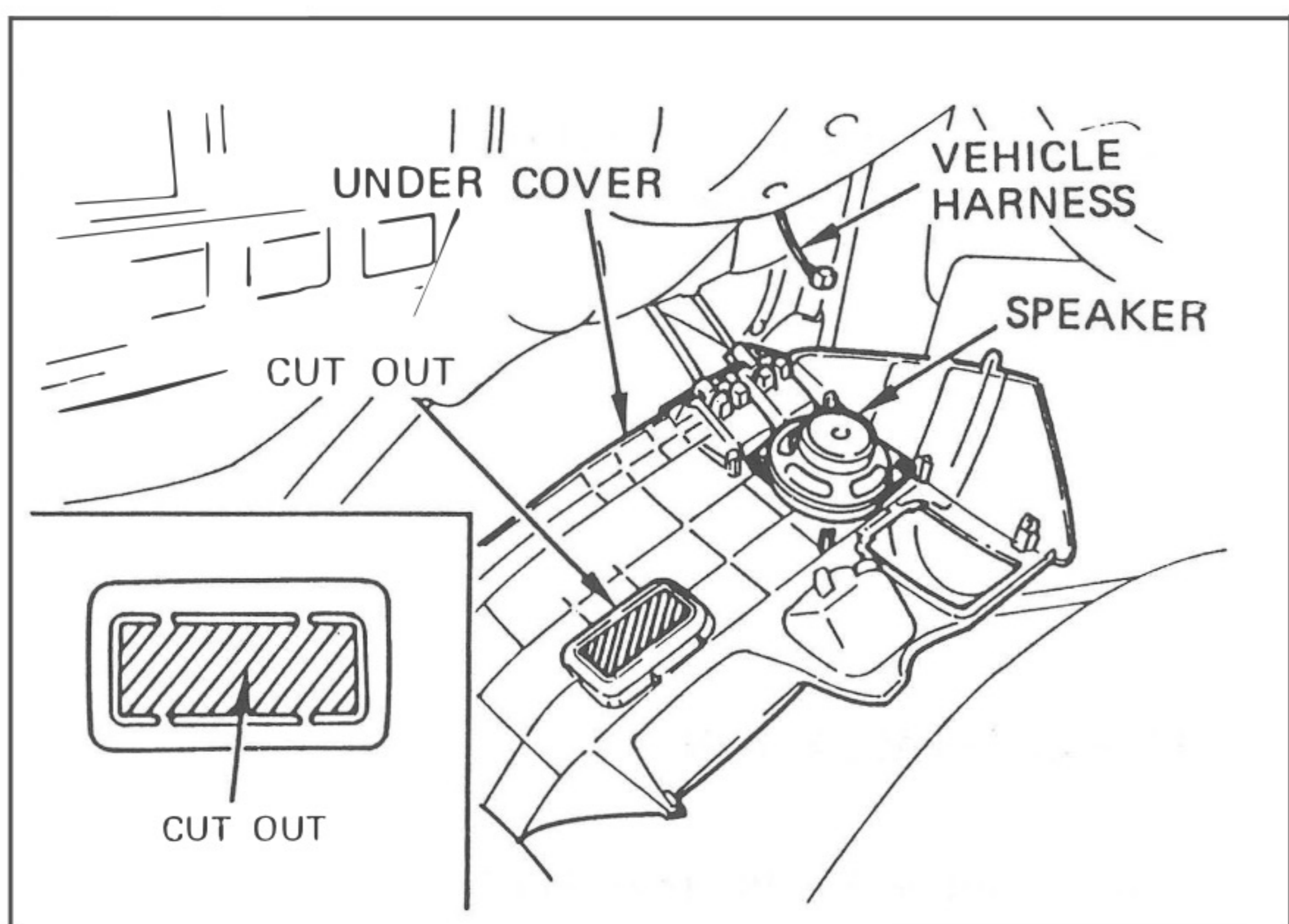

Fig. 14

- (c) Disconnect the vehicle harness from the speaker.
- (d) Cut out the shaded area of the under cover.

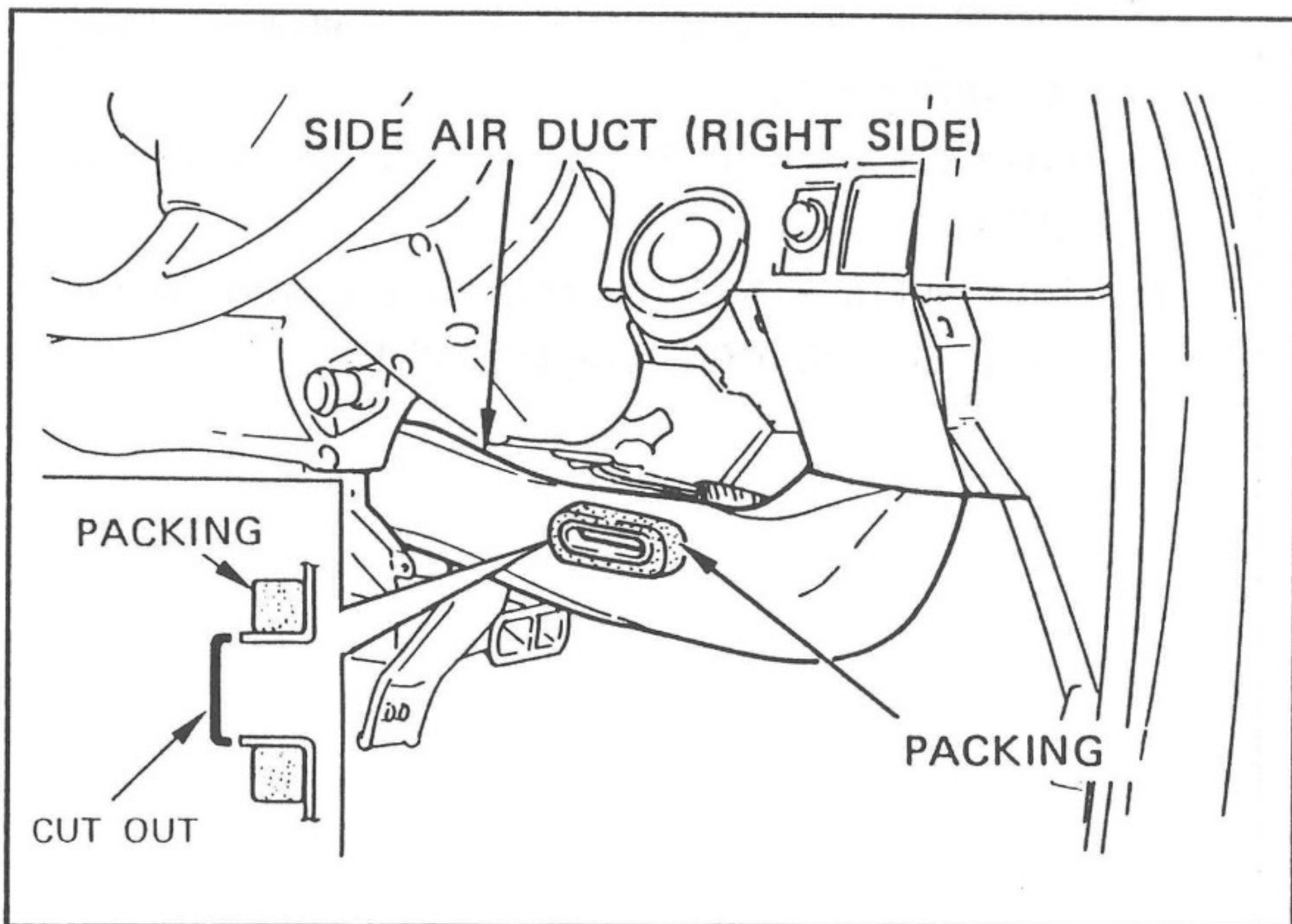

Fig. 15

- (e) Cut out the indicated part of side air duct.
- (f) Attach the packing around the air outlet port of side air duct as shown.

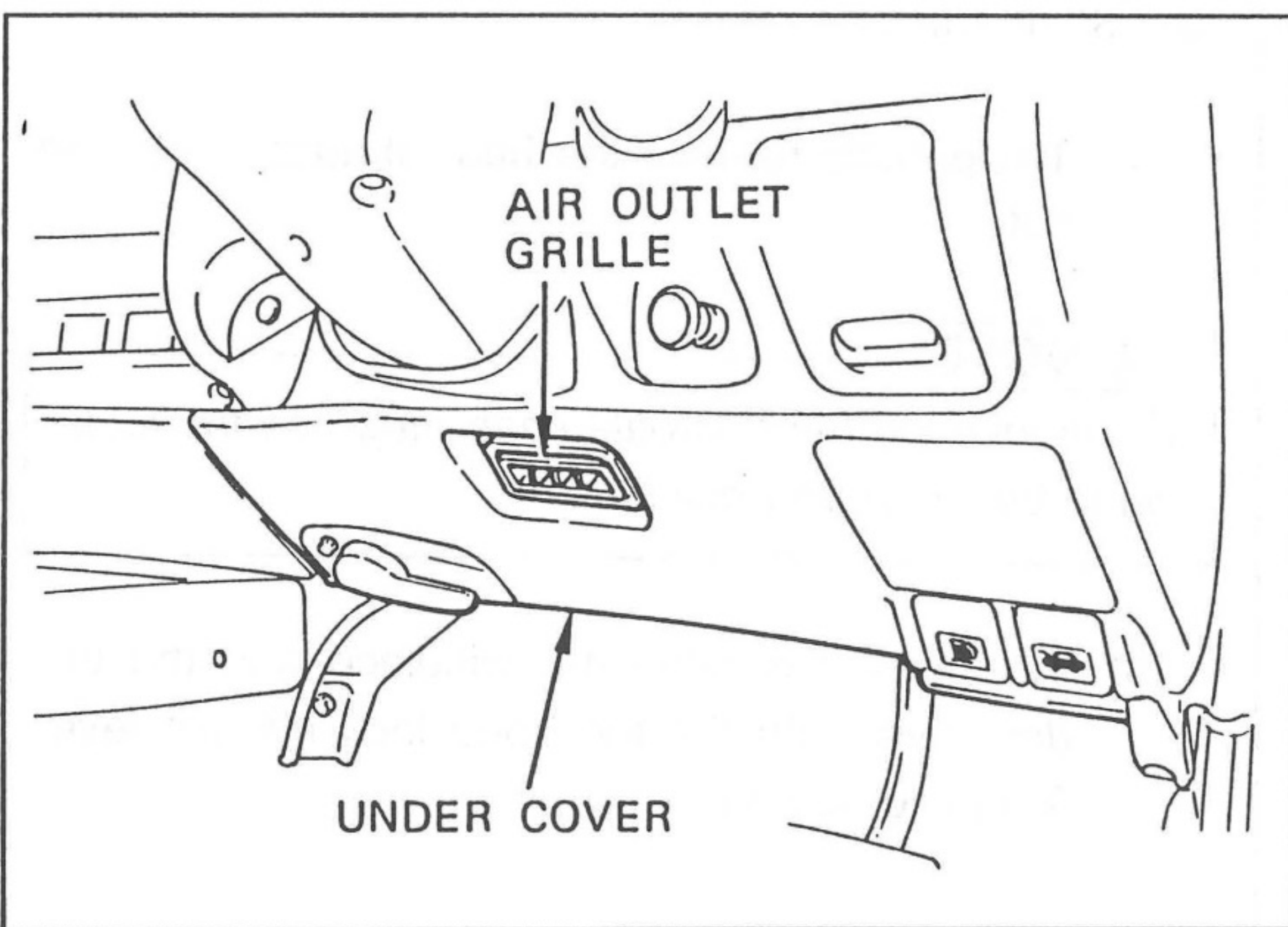

Fig. 16

- (g) Reconnect the vehicle harness to speaker.
- (h) Reinstall the under cover.
- (i) Install the air outlet grille into the under cover.

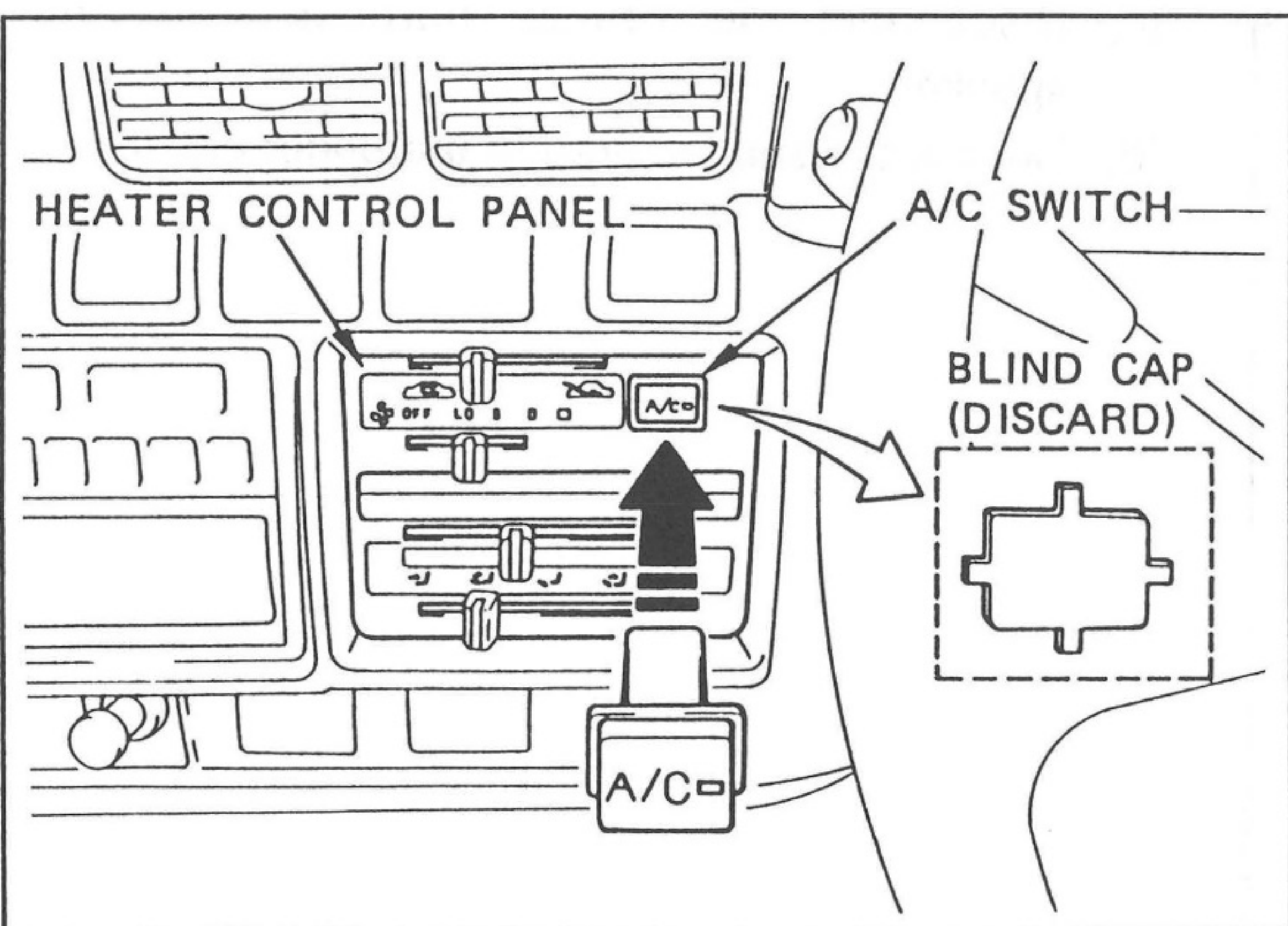

Fig. 17

(4) A/C SWITCH

- (a) Cut out the blind cap of heater control panel.
- (b) Install the A/C switch.

(5) REINSTALLATION

- (a) Reinstall the temporarily removed parts.

1.2 INSTALLATION : ENGINE COMPARTMENT

- ※ Before making any hoses and tubes connections, apply a few drops of refrigerant oil to the seal of O-ring and coupling nuts.
- ※ When tightening and loosening fittings, use two wrenches for support.
- ※ Ensure fender covers are in position.

■ PIPING LAYOUT

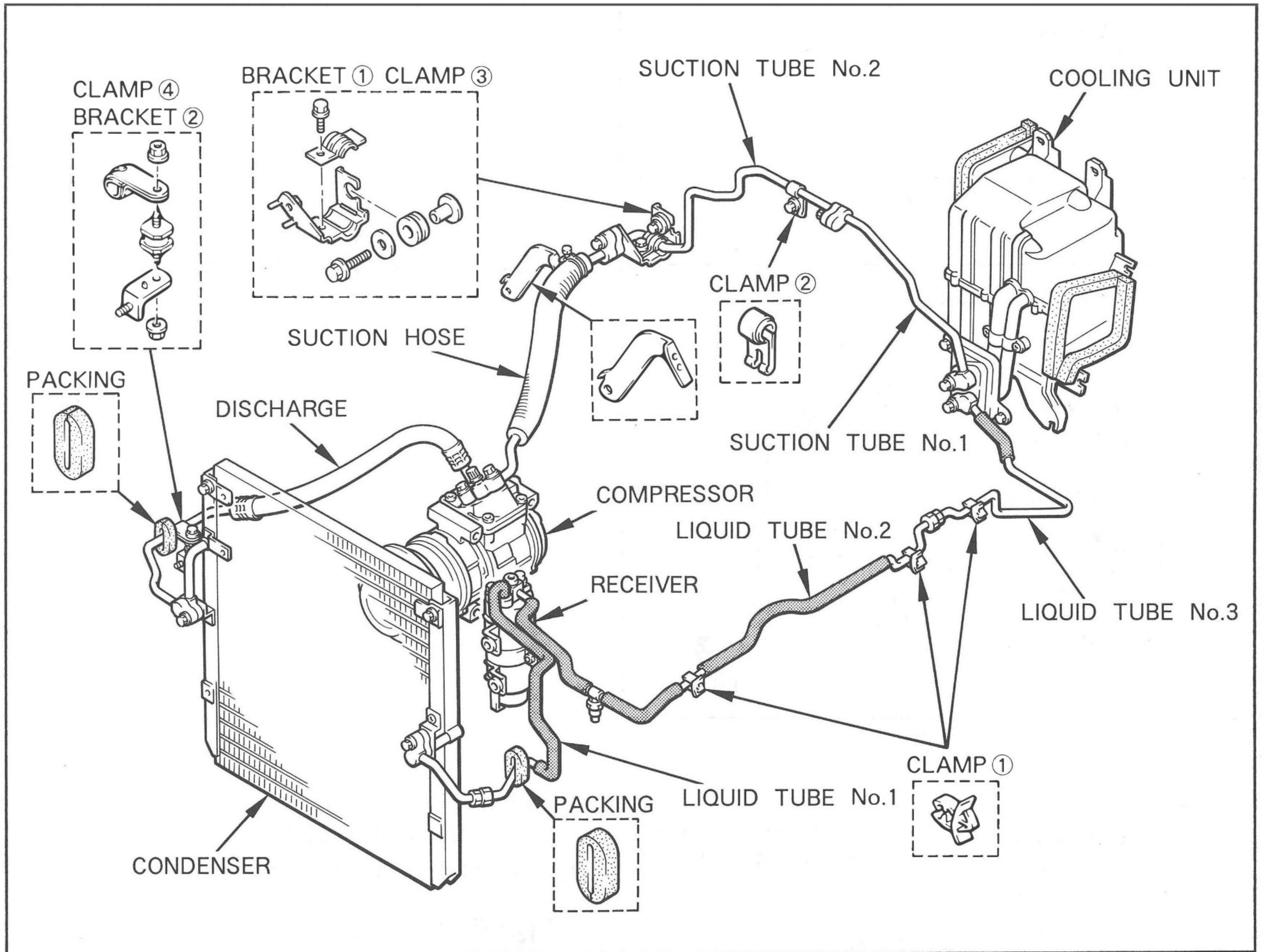

Fig. 18

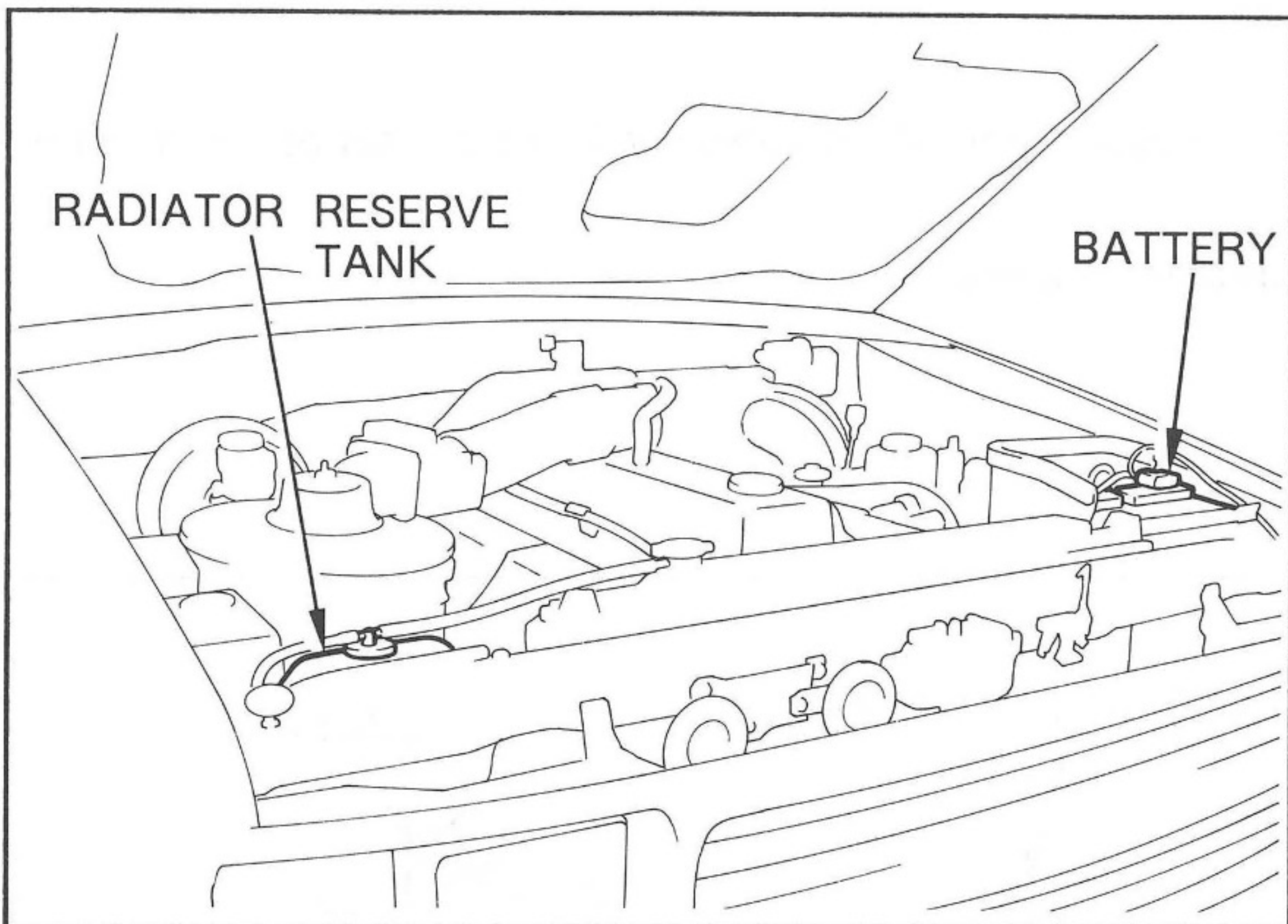

Fig. 19

(1) REMOVAL OF PARTS

- (a) Radiator reserve tank
- (b) Battery
- (c) Under cover

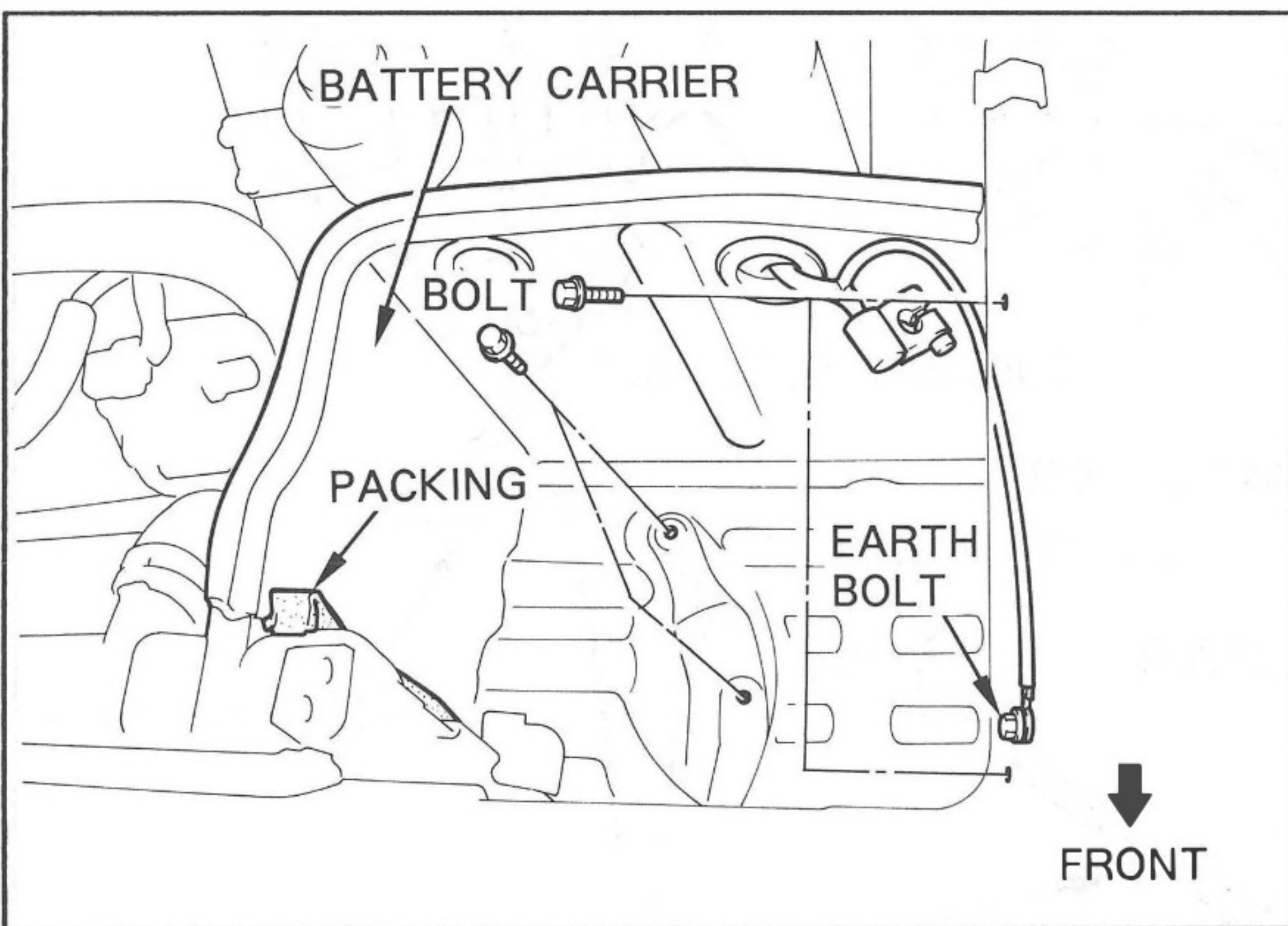

Fig. 20

- (d) Earth bolt, battery and packing.

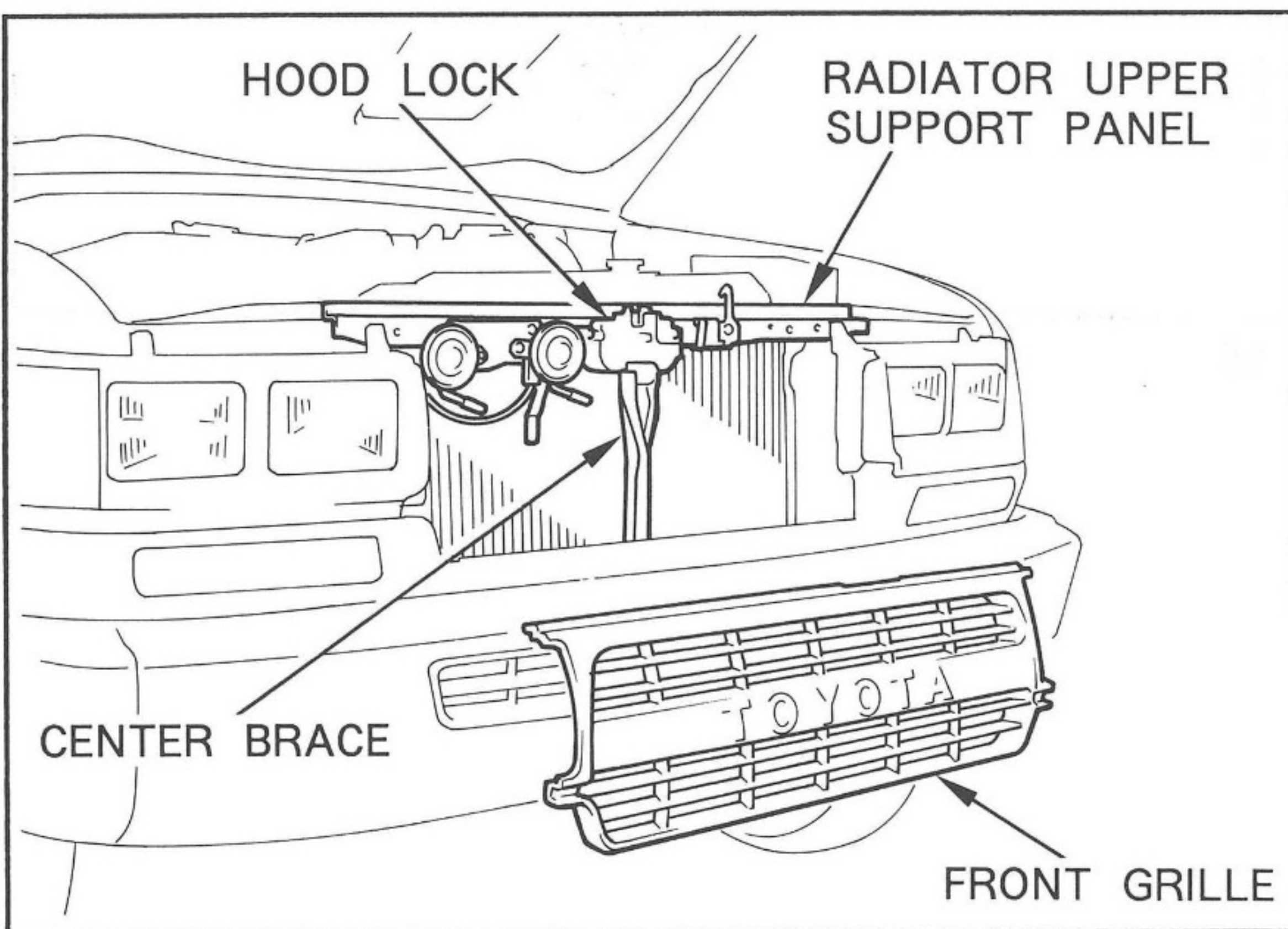

Fig. 21

- (e) Front grille
- (f) Hood lock and center brace
- (g) Radiator upper support panel

NOTE

- 1) *Disconnect the horn harness.*
- 2) *Unclip the vehicle harness from the radiator upper support panel.*

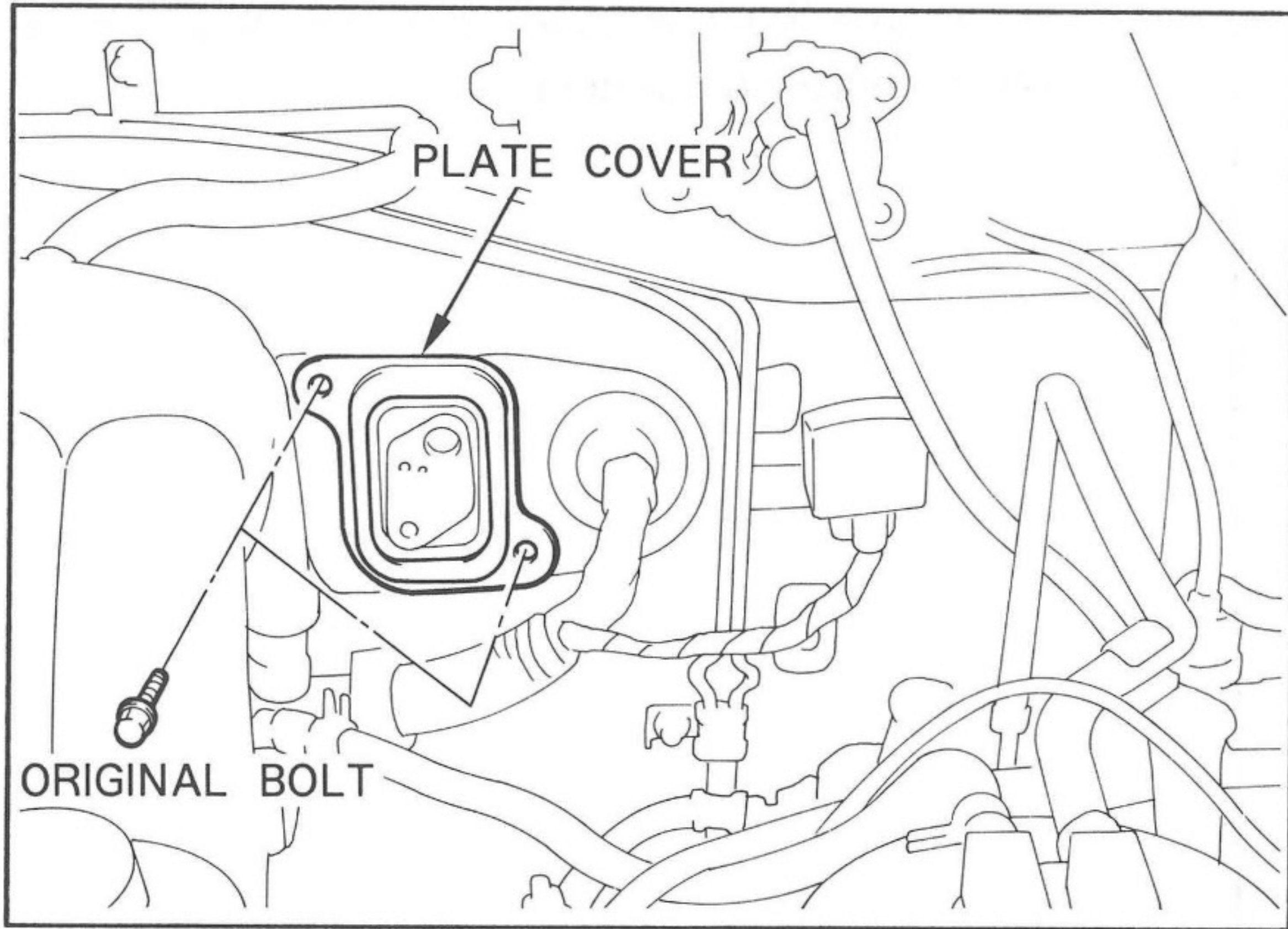

Fig. 22

(2) PLATE COVER

- (a) Install the plate cover supplied in the kit on the bulkhead using two original bolts.

(3) COMPRESSOR

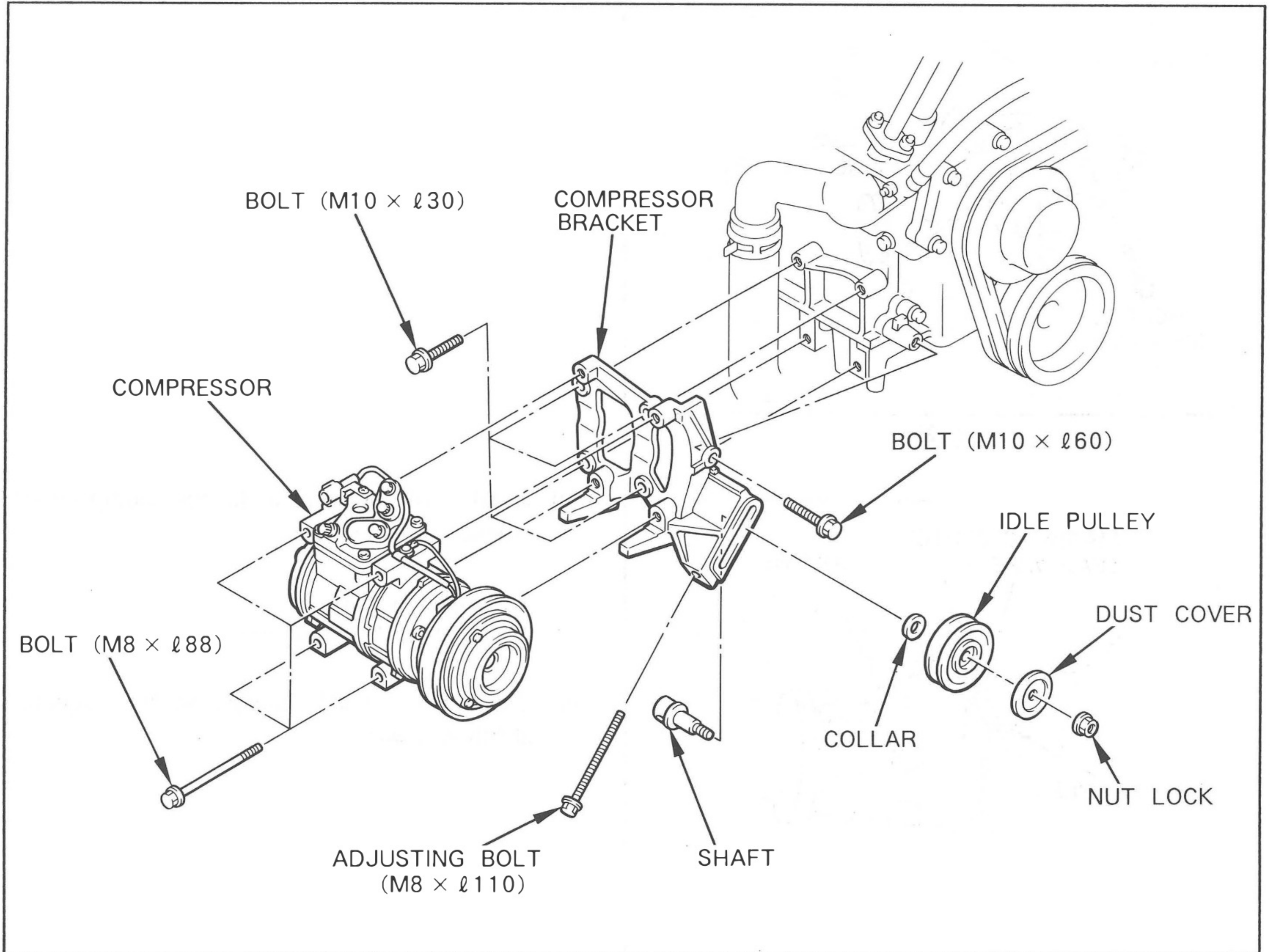

Fig. 23

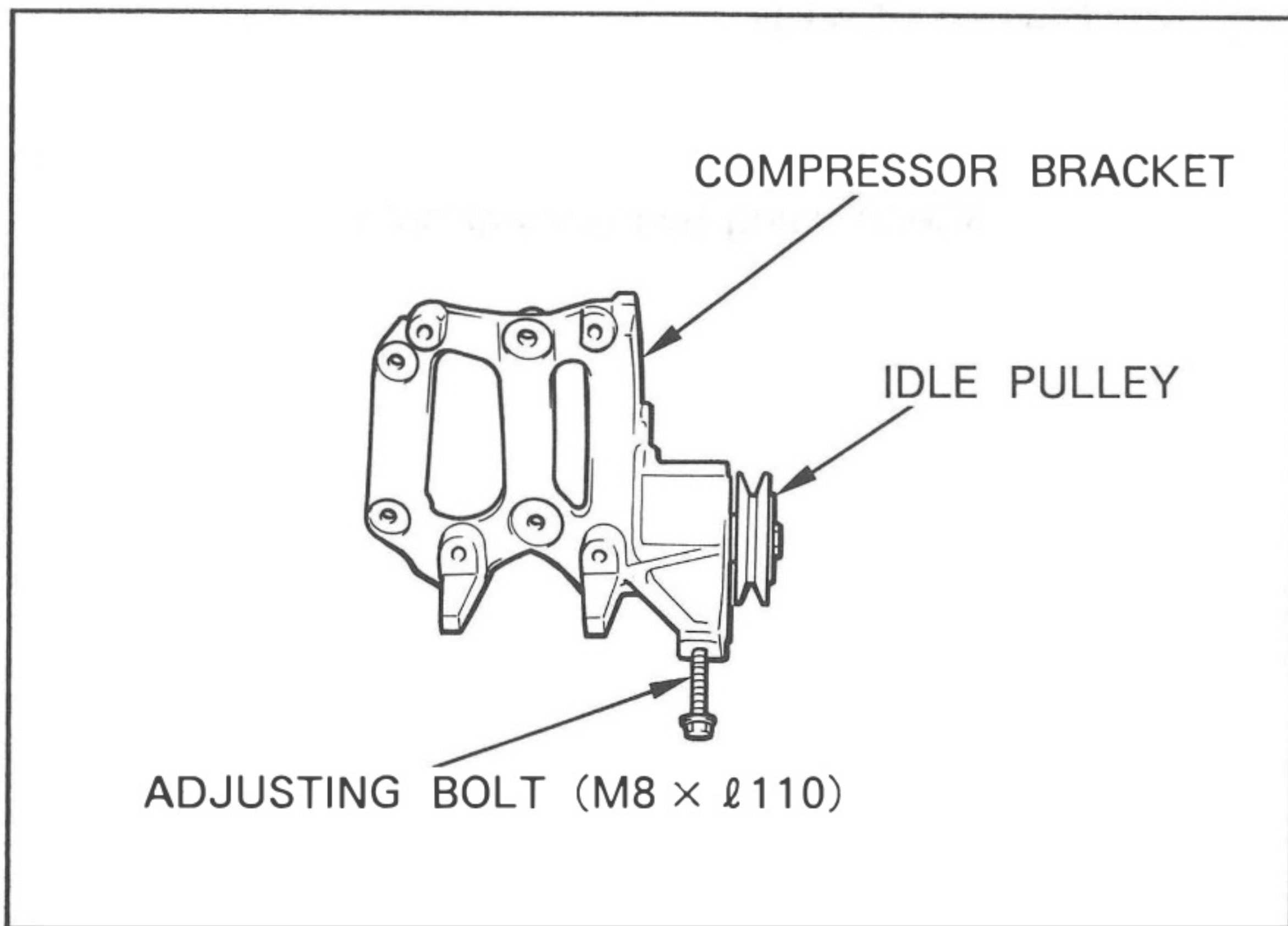

Fig. 24

- (a) Assemble the idle pulley and adjusting bolt to the compressor bracket.

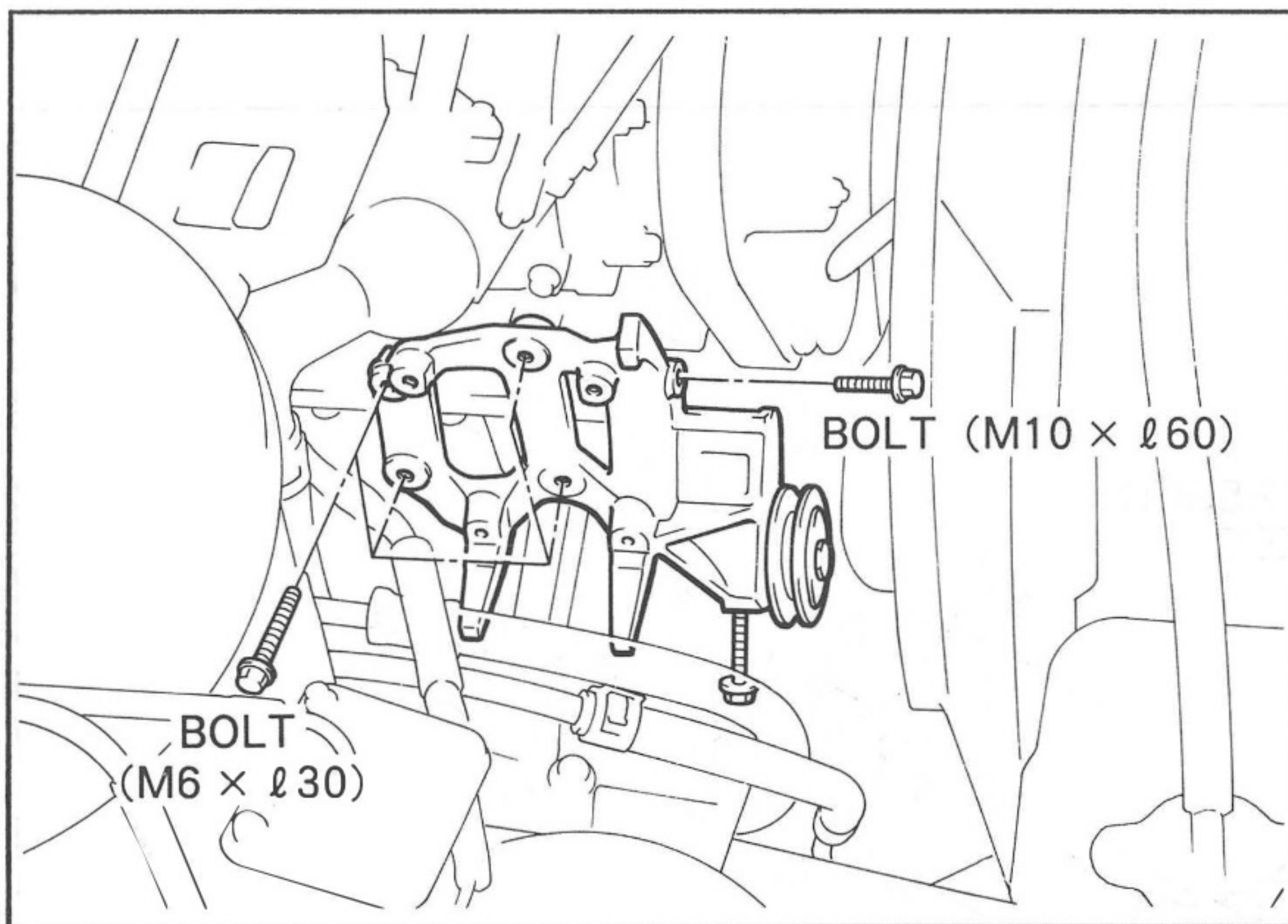

Fig. 25

- (b) Install the compressor bracket to the engine block using five bolts.

Tightening Torque :

36.8 N · m (375 kgf · cm, 27.1 ft · lbf)

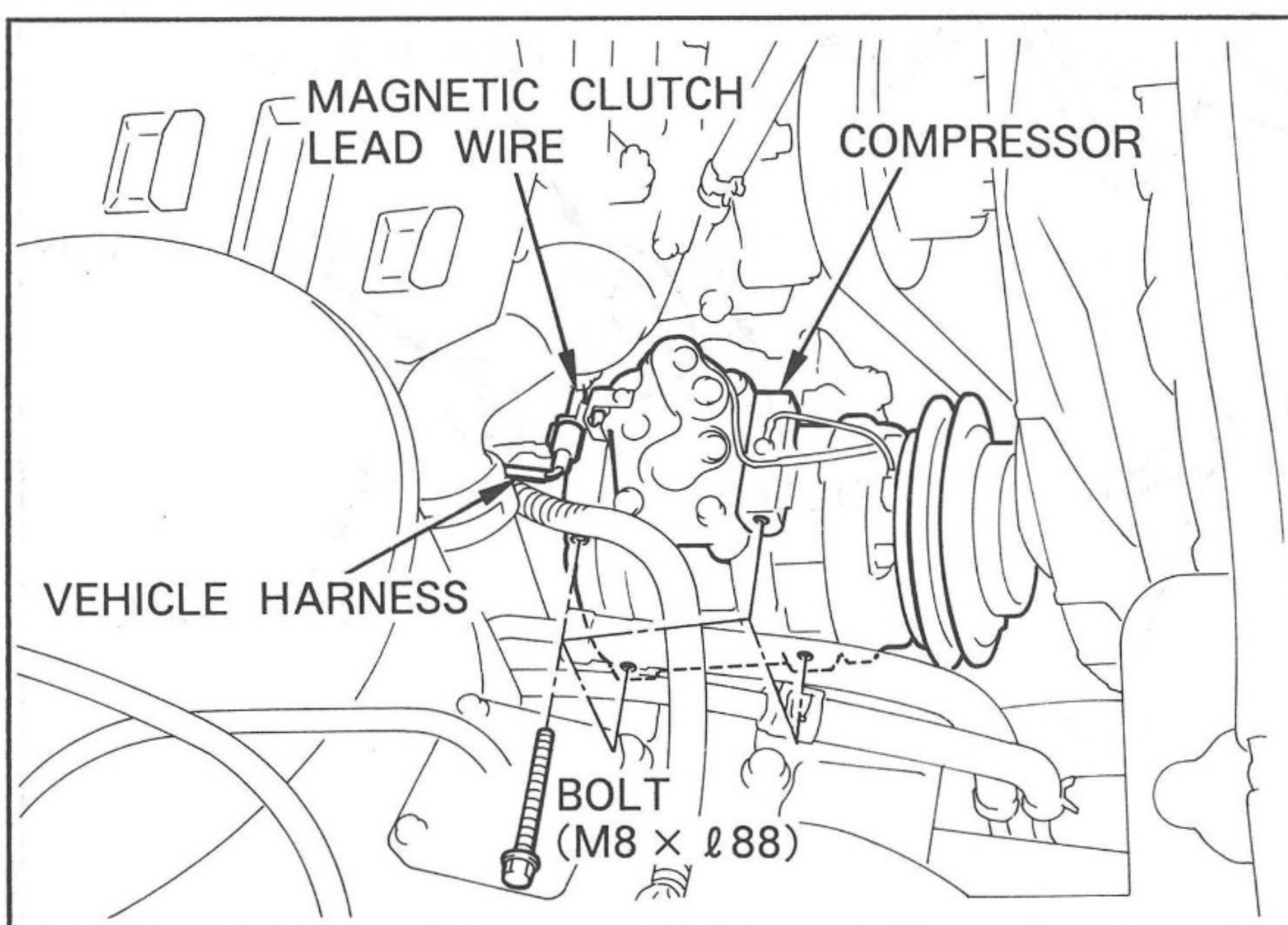

Fig. 26

- (c) Install the compressor to the compressor bracket using four bolts.

Tightening Torque :

24.5 N · m (250 kgf · cm, 18.1 ft · lbf)

- (d) Connect the vehicle harness to the magnetic clutch lead wire.

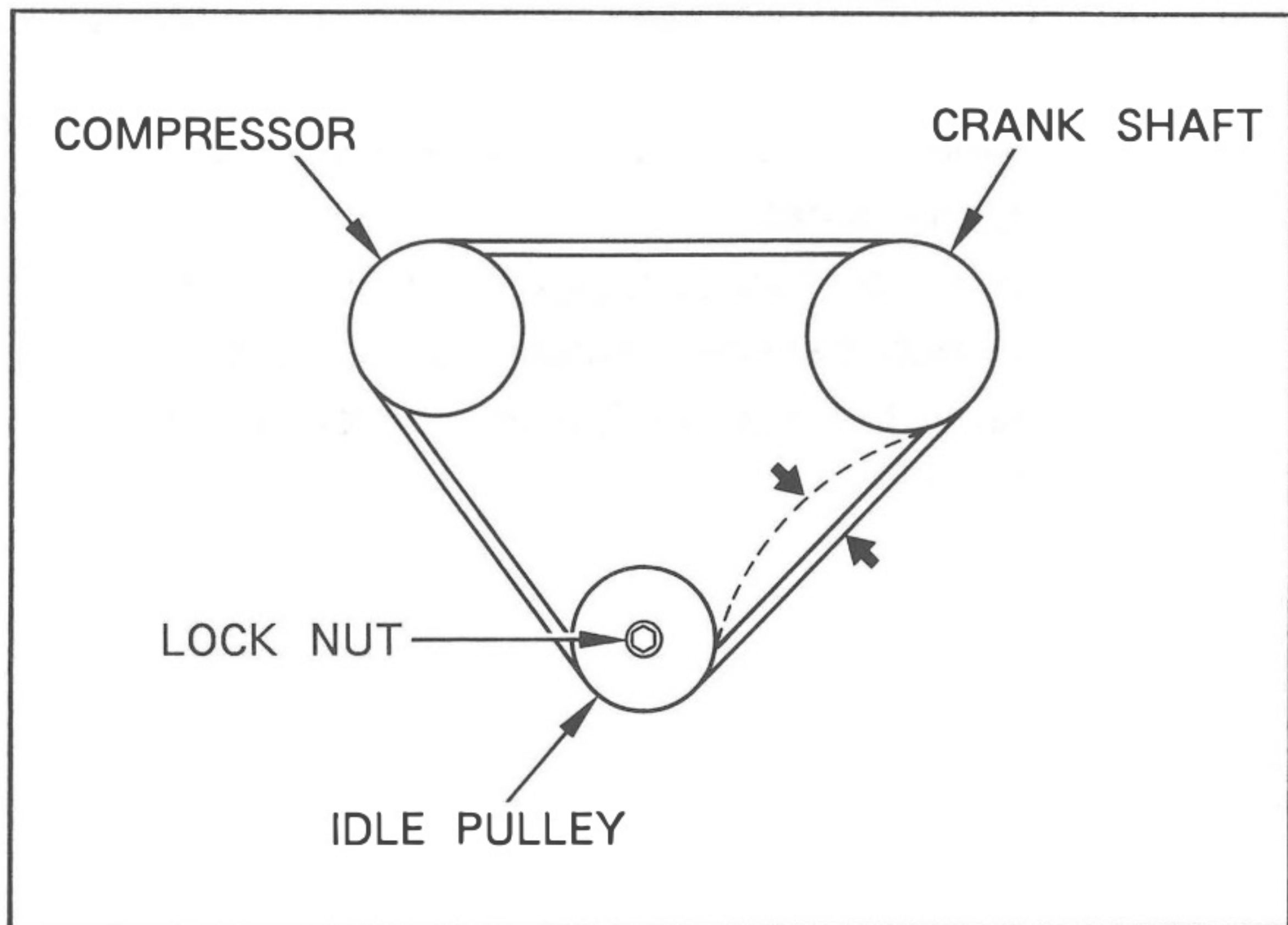

Fig. 27

- (e) Install the compressor drive belt, and adjust its tension by turning the adjusting bolt.
- (f) Check the belt tension using the belt tension gauge.

	Belt deflection at 98N · (10 kgf, 22 lbf) force	Belt tension using the belt tension gauge
New belt	5-7 mm (0.20-0.28 inch)	38-62 kgf (100-150 lbf)
Used belt	7-9.5 mm (0.28-0.37 inch)	20-40 kgf (60-100 lbf)

- (g) Tighten the lock nut of idle pulley.

Tightening Torque :

39.2 N · m (400 kgf · cm, 28.9 ft · lbf)

(4) CONDENSER

- (a) Attach the packing to the bottom of radiator.
- (b) Remove and discard two blind caps from the frame.

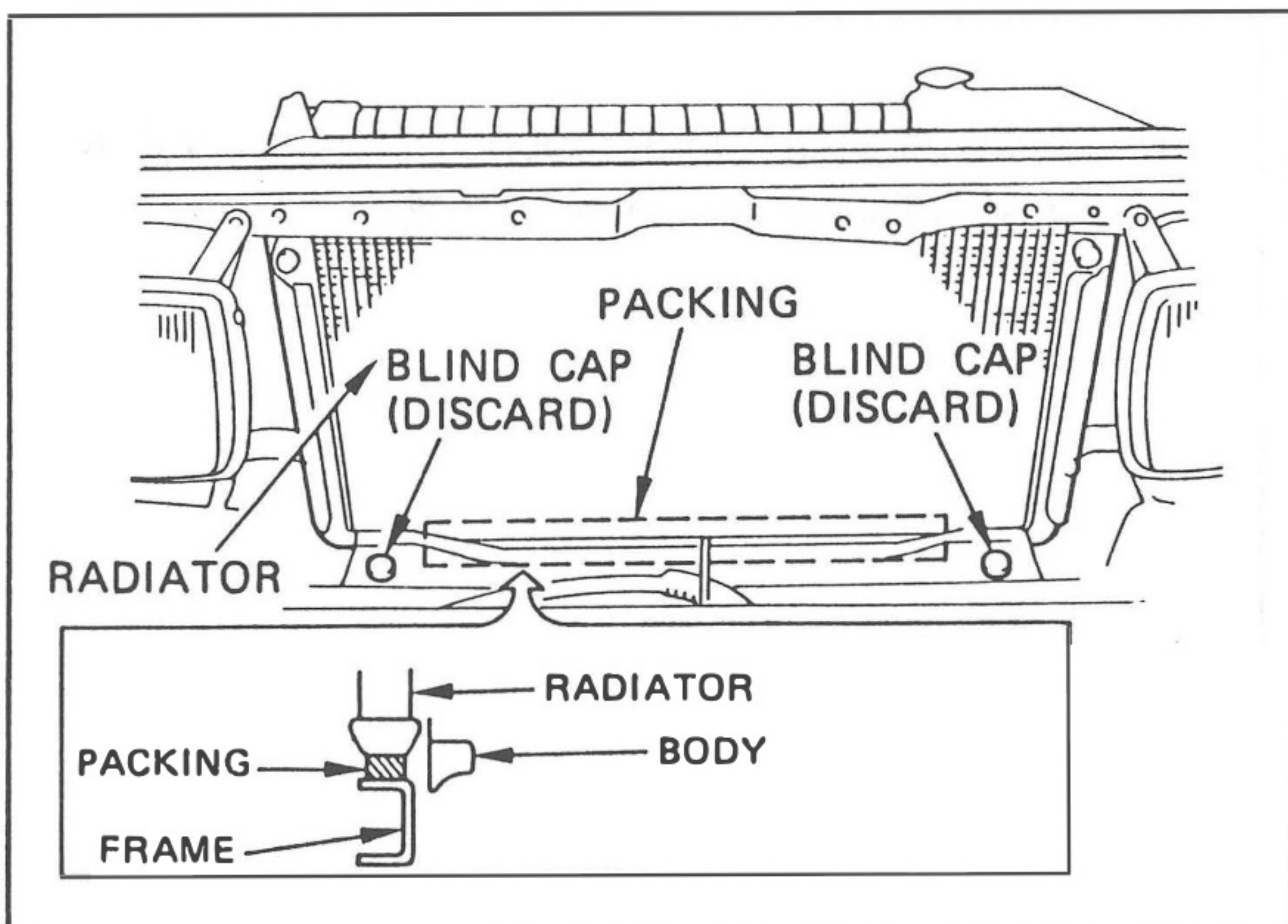

Fig. 28

- (c) Insert the condenser in front of the radiator.

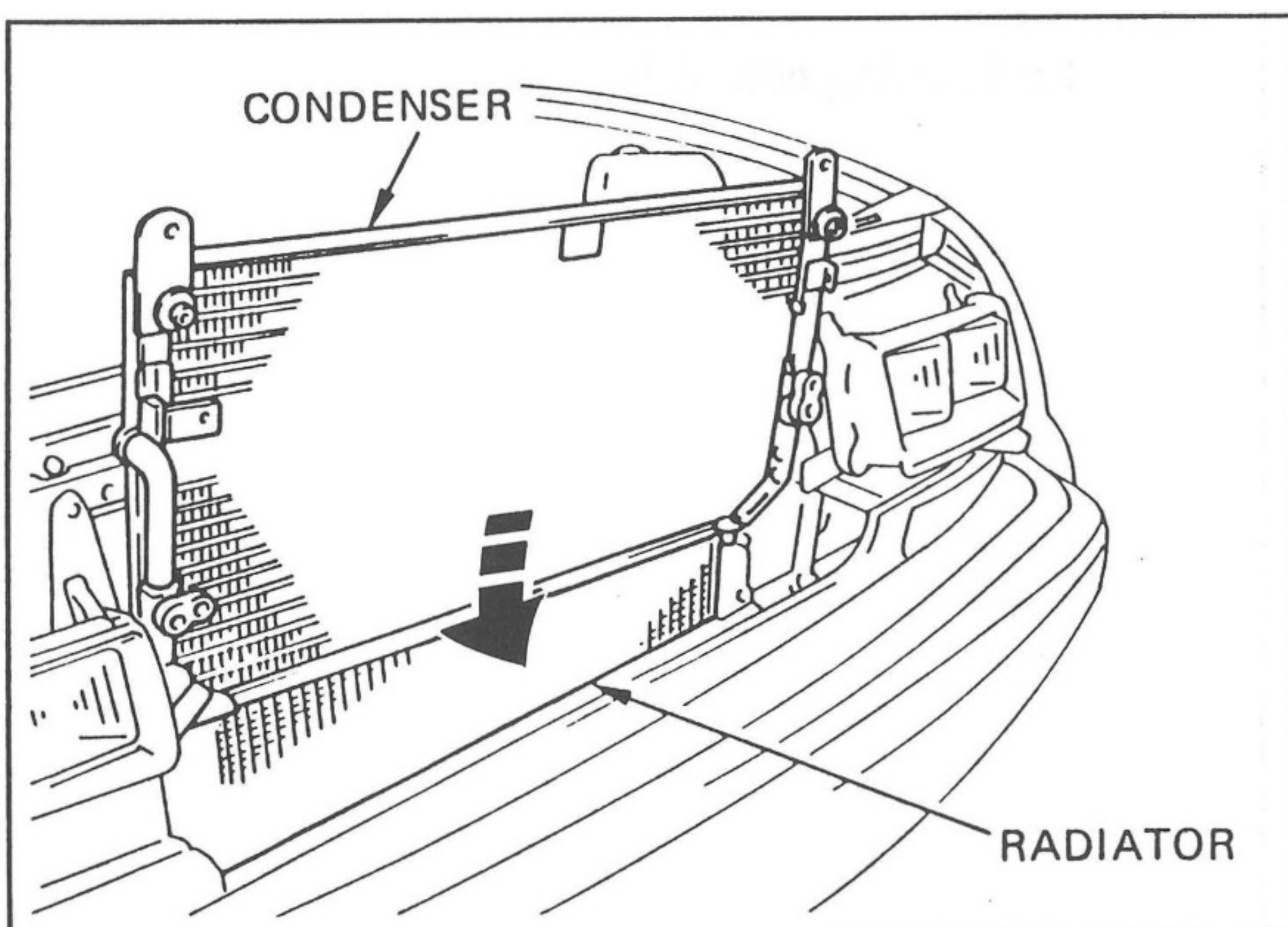

Fig. 29

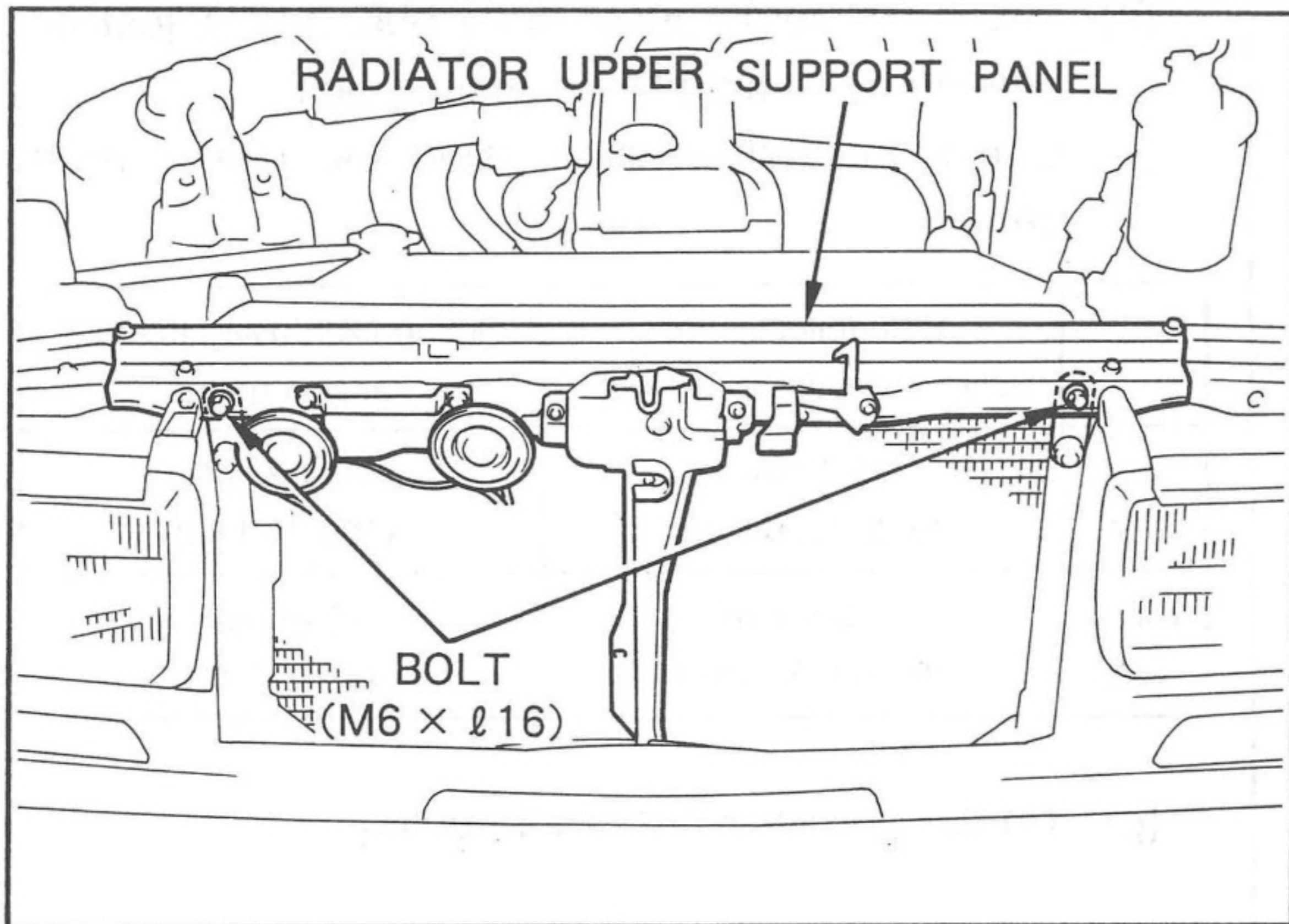

Fig. 30

- (d) Reinstall the radiator upper support panel and connect the horn harness to the horns, and clip in the vehicle harness to the radiator upper support panel.
- (e) Fasten the two condenser brackets to the radiator upper support panel using two bolts.
- (f) Fasten the two condenser brackets to the condenser

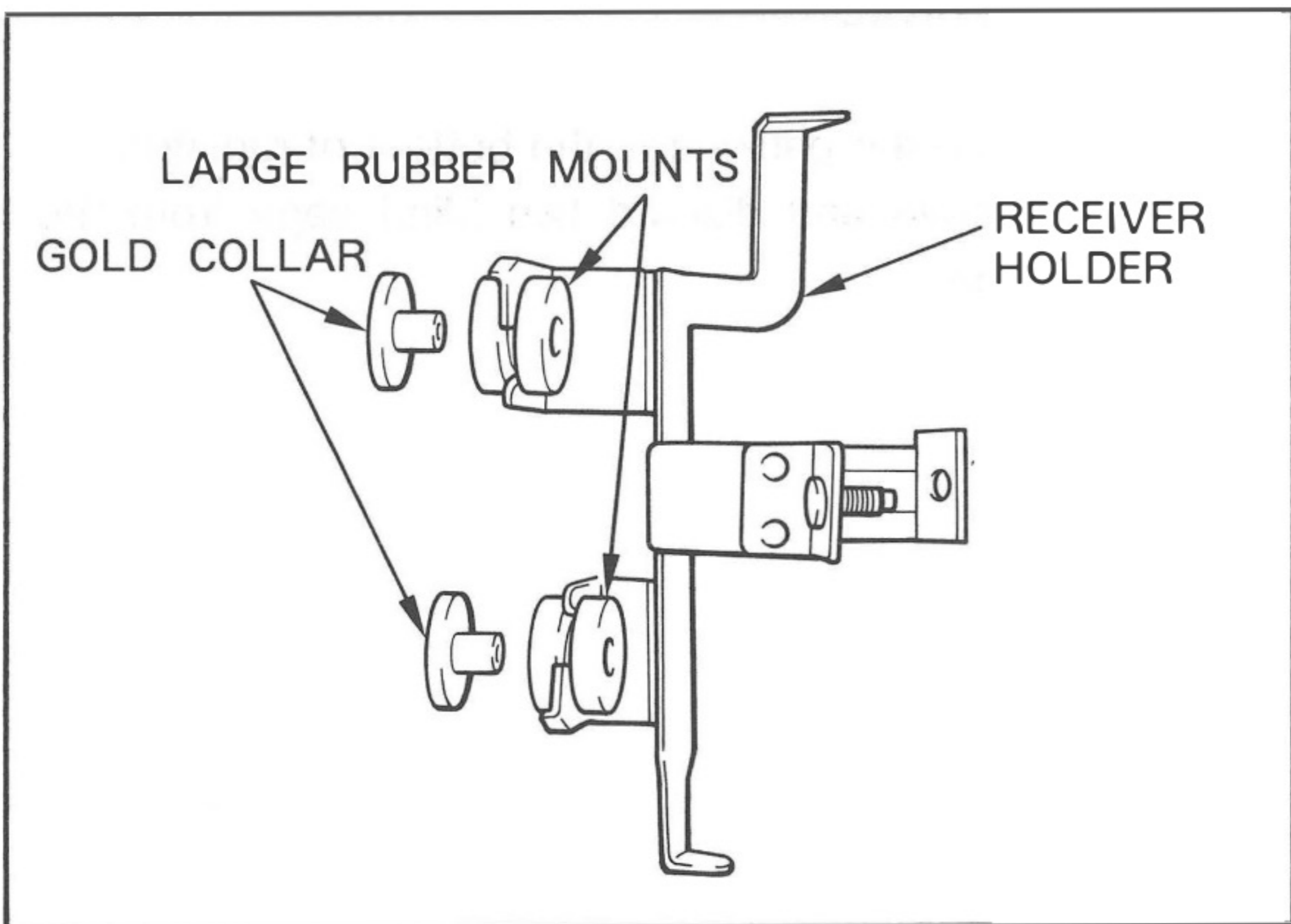

Fig. 31

(5) RECEIVER

- (a) Assemble two large rubber mounts and two gold collars to the receiver holder.

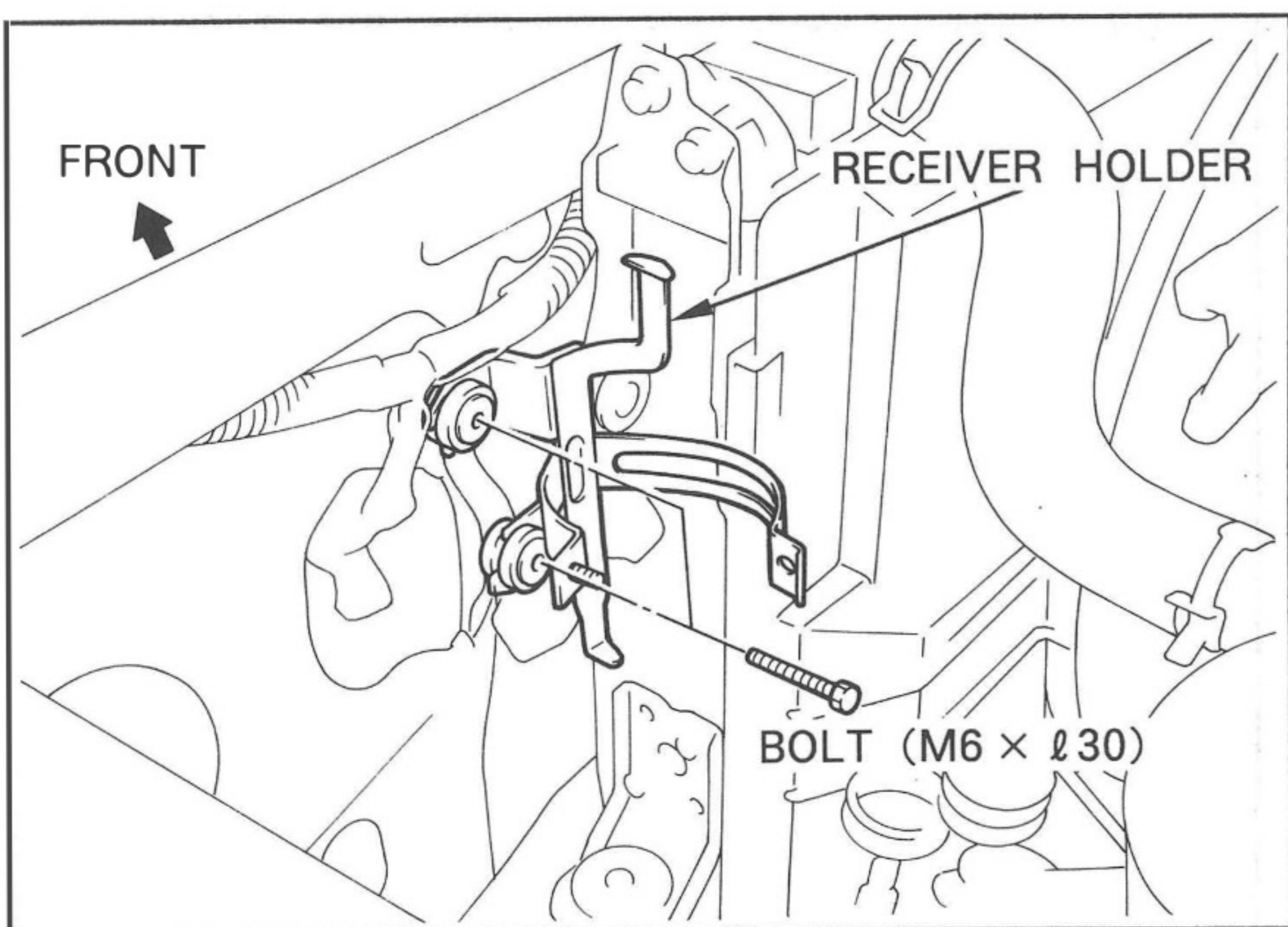

Fig. 32

- (b) Install the receiver holder to the radiator side baffle using two bolts.

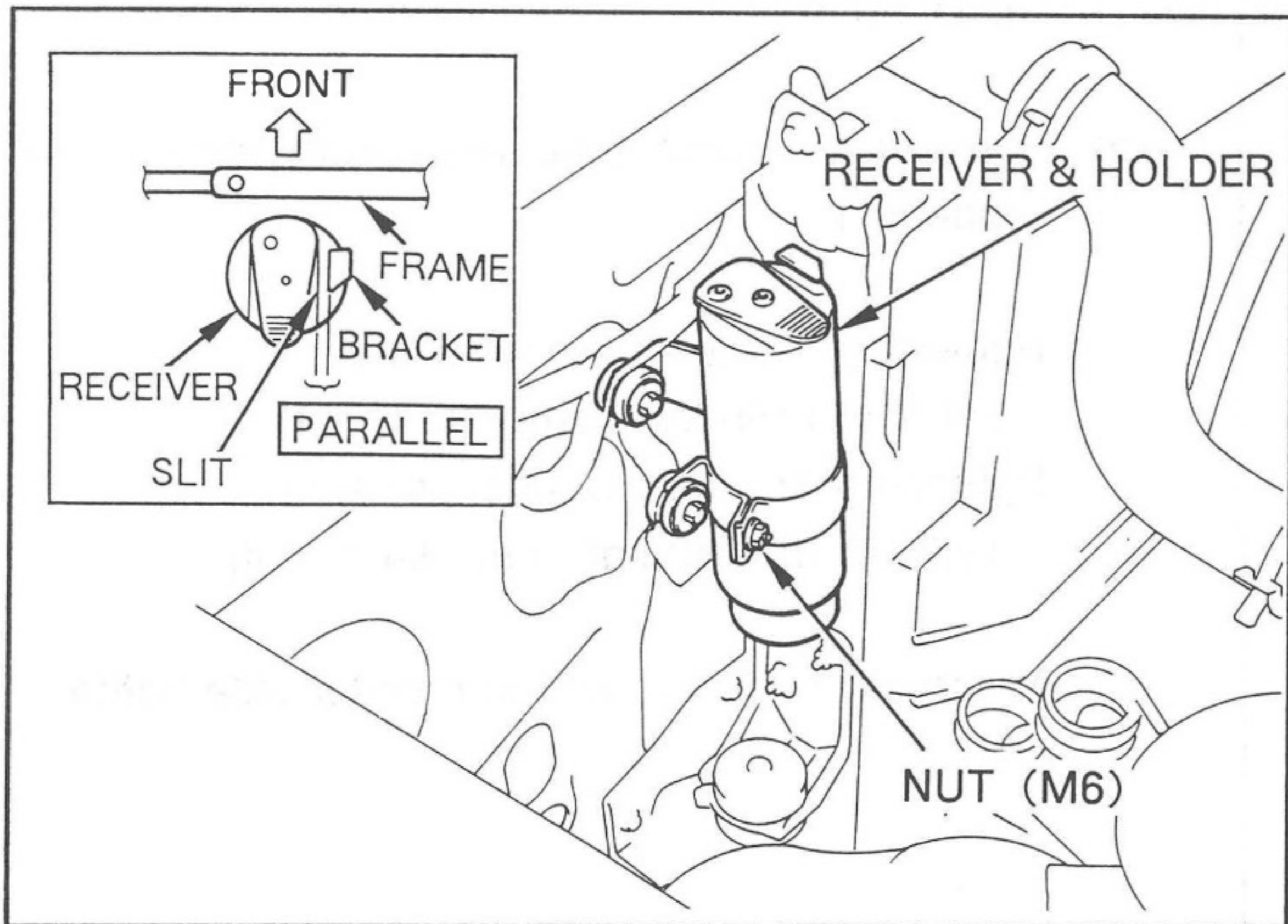

Fig. 33

- (c) Place the receiver in the receiver holder and fasten a nut.

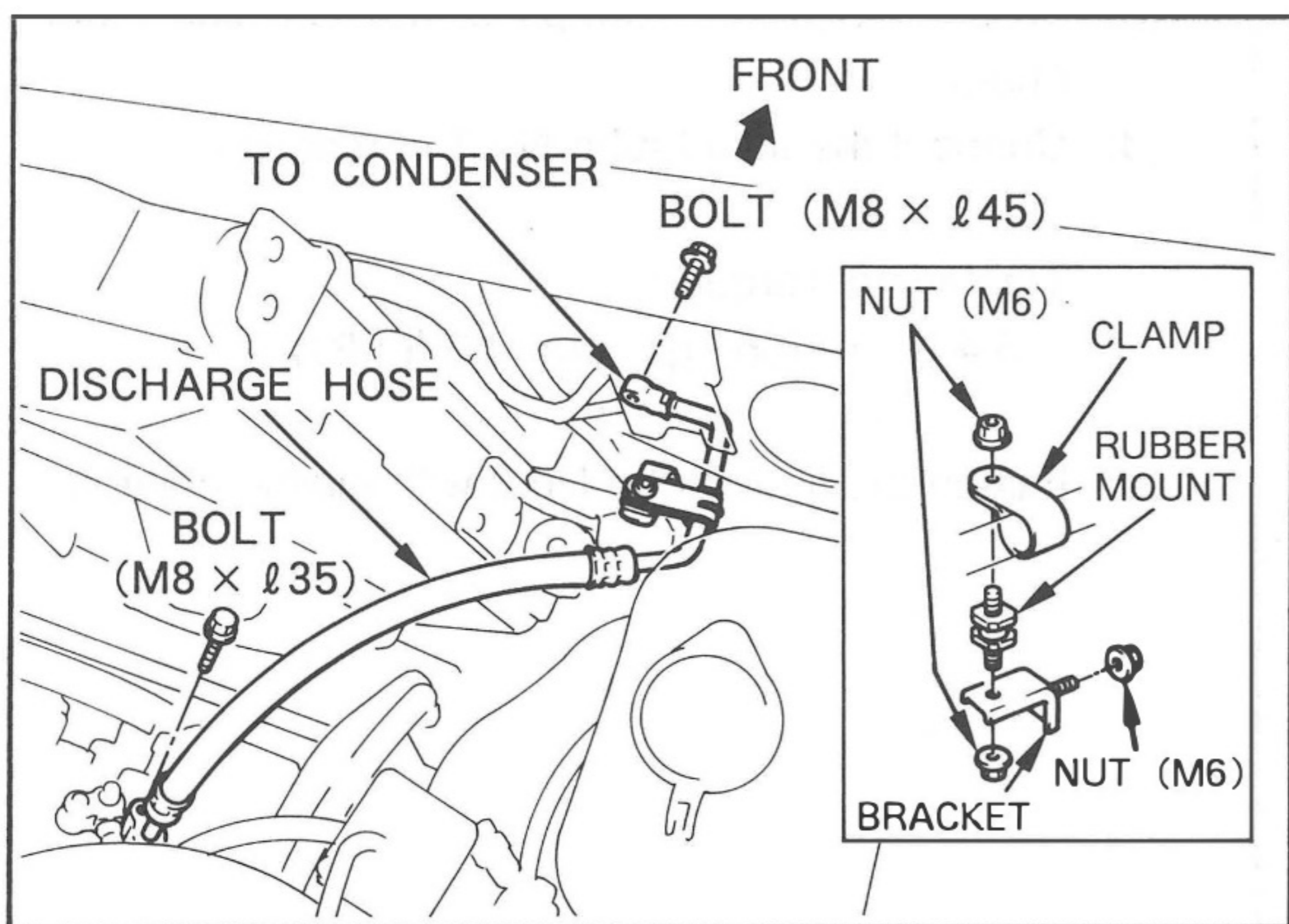

Fig. 34

(6) DISCHARGE HOSE

- (a) Assemble the clamp, rubber mount, and bracket to the discharge hose.
- (b) Connect the discharge hose to the condenser.
Tightening Torque :
12.7 N · m (130 kgf · cm, 9.4 ft · lbf)
- (c) Connect the discharge hose to the compressor.
Tightening Torque :
24.5 N · m (250 kgf · cm, 18.1 ft · lbf)
- (d) Fasten the clamp to the radiator side baffle using a nut.

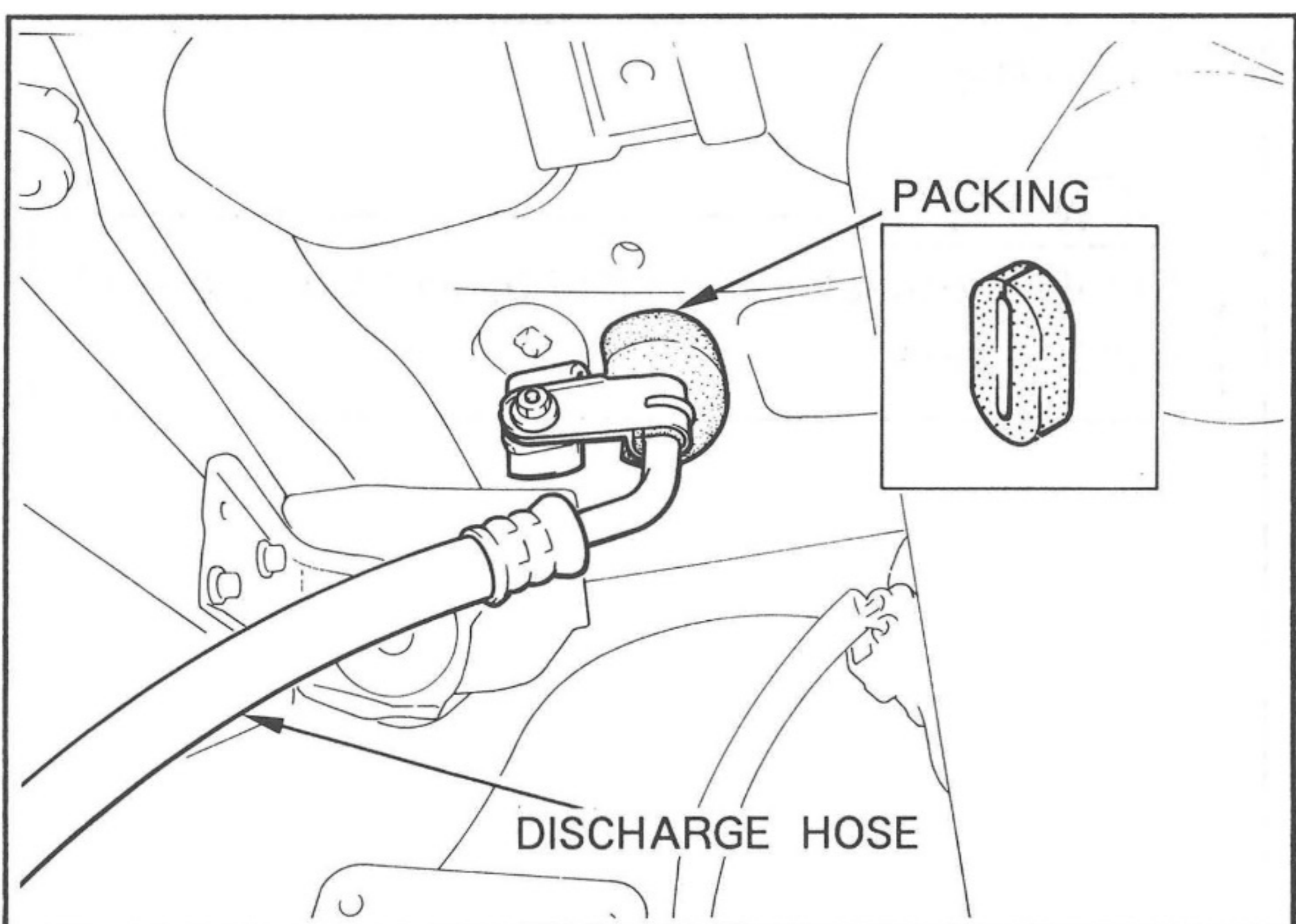

Fig. 35

- (e) Attach a packing to the radiator side baffle.

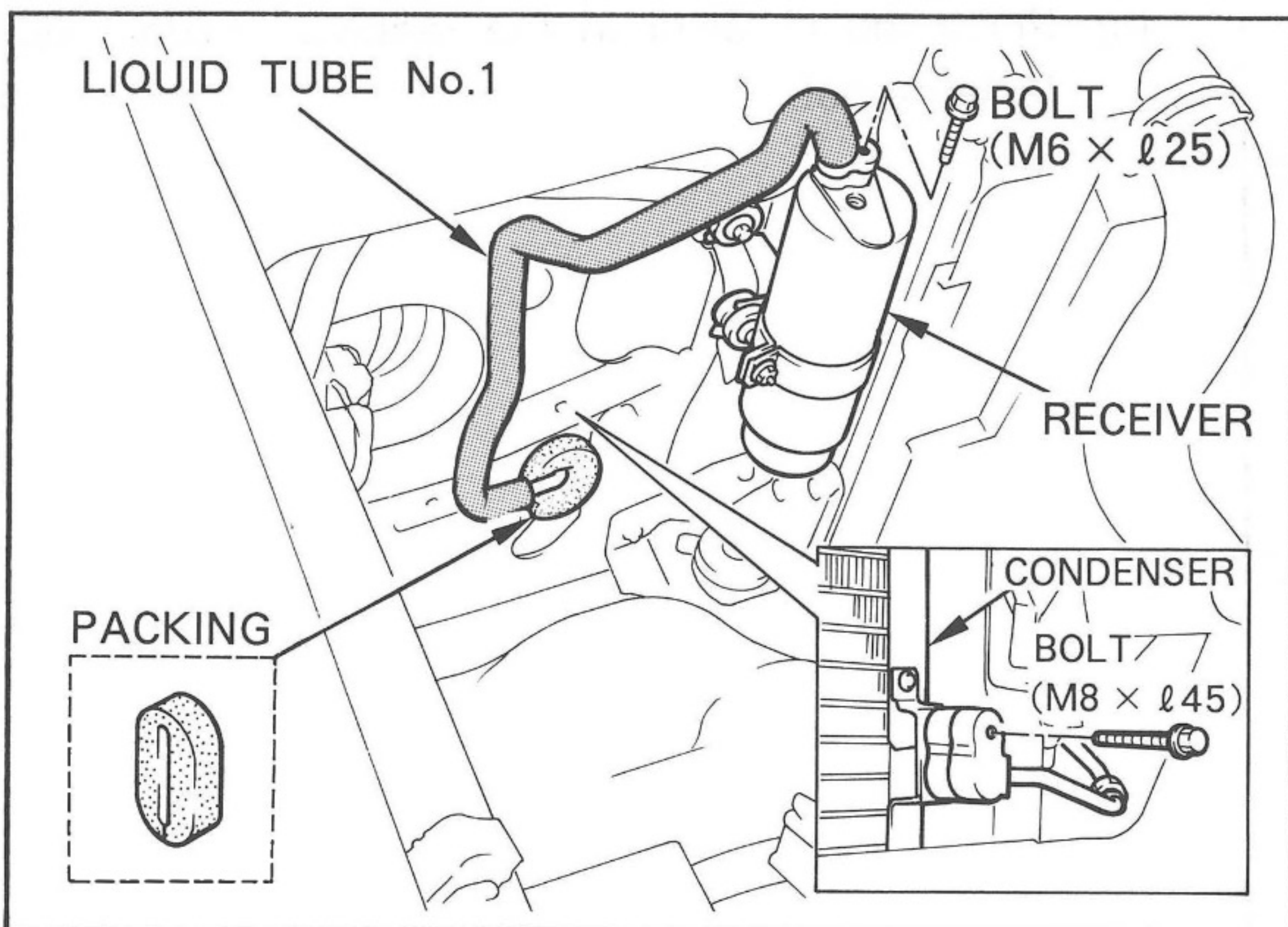

Fig. 36

(7) LIQUID TUBE

- (a) Connect the liquid tube No.1 from receiver to condenser.

Tightening Torque : Receiver side

5.4 N · m (55 kgf · cm, 4.0 ft · lbf)

Tightening Torque : Condenser side

12.7 N · m (130 kgf · cm, 9.4 ft · lbf)

- (b) Attach the packing into the radiator side baffle.

- (c) Install two plastic clamps to the left side inner guard.

- (d) Connect the liquid tube No.2 to receiver.

Tightening Torque :

5.4 N · m (55 kgf · cm, 4.0 ft · lbf)

- (e) Fasten the liquid tube No.2 with plastic clamps.

- (f) Connect the vehicle harness to the pressure switch.

NOTE

The 4-P connector is located behind the left hand side headlight.

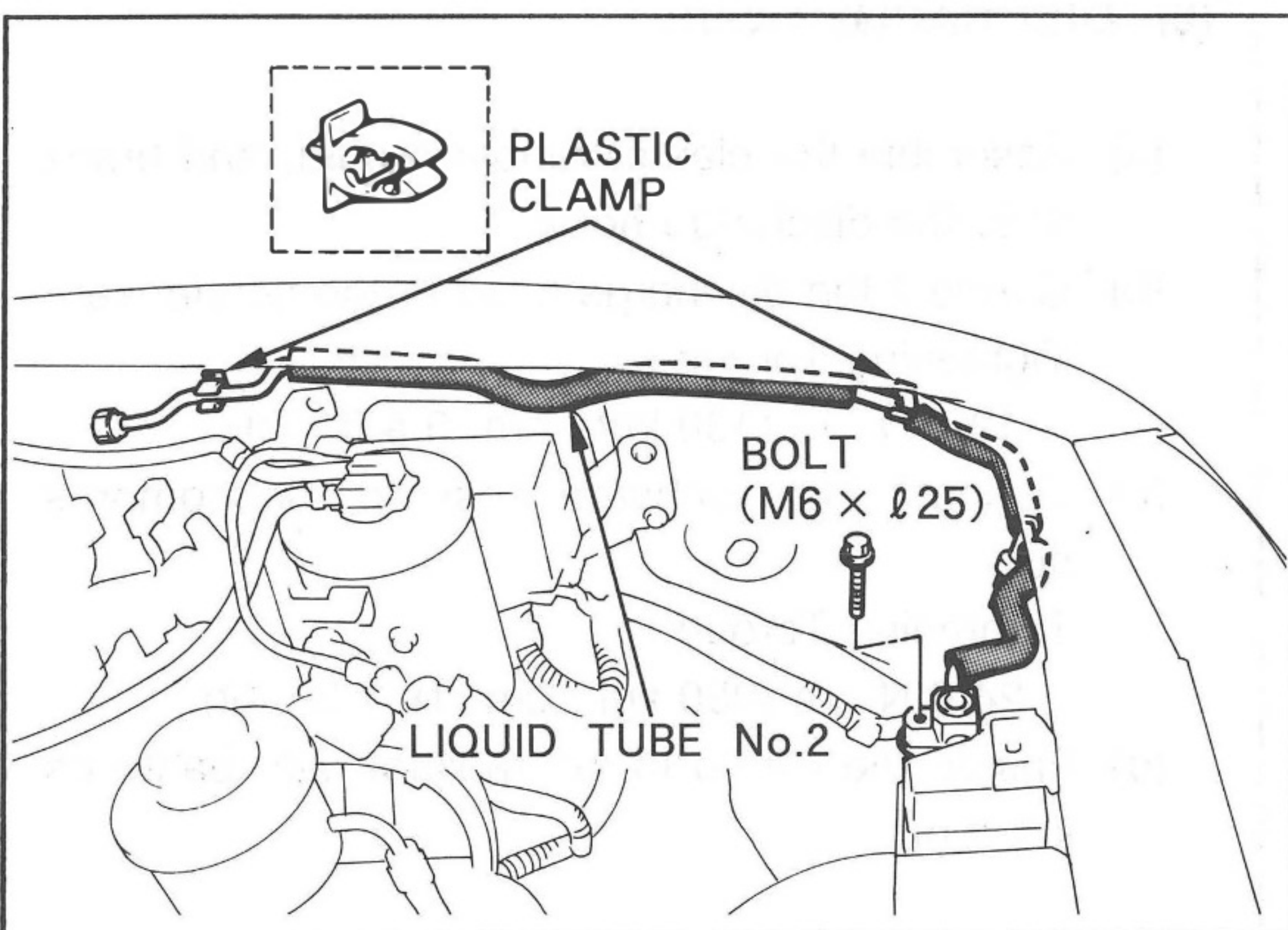

Fig. 37

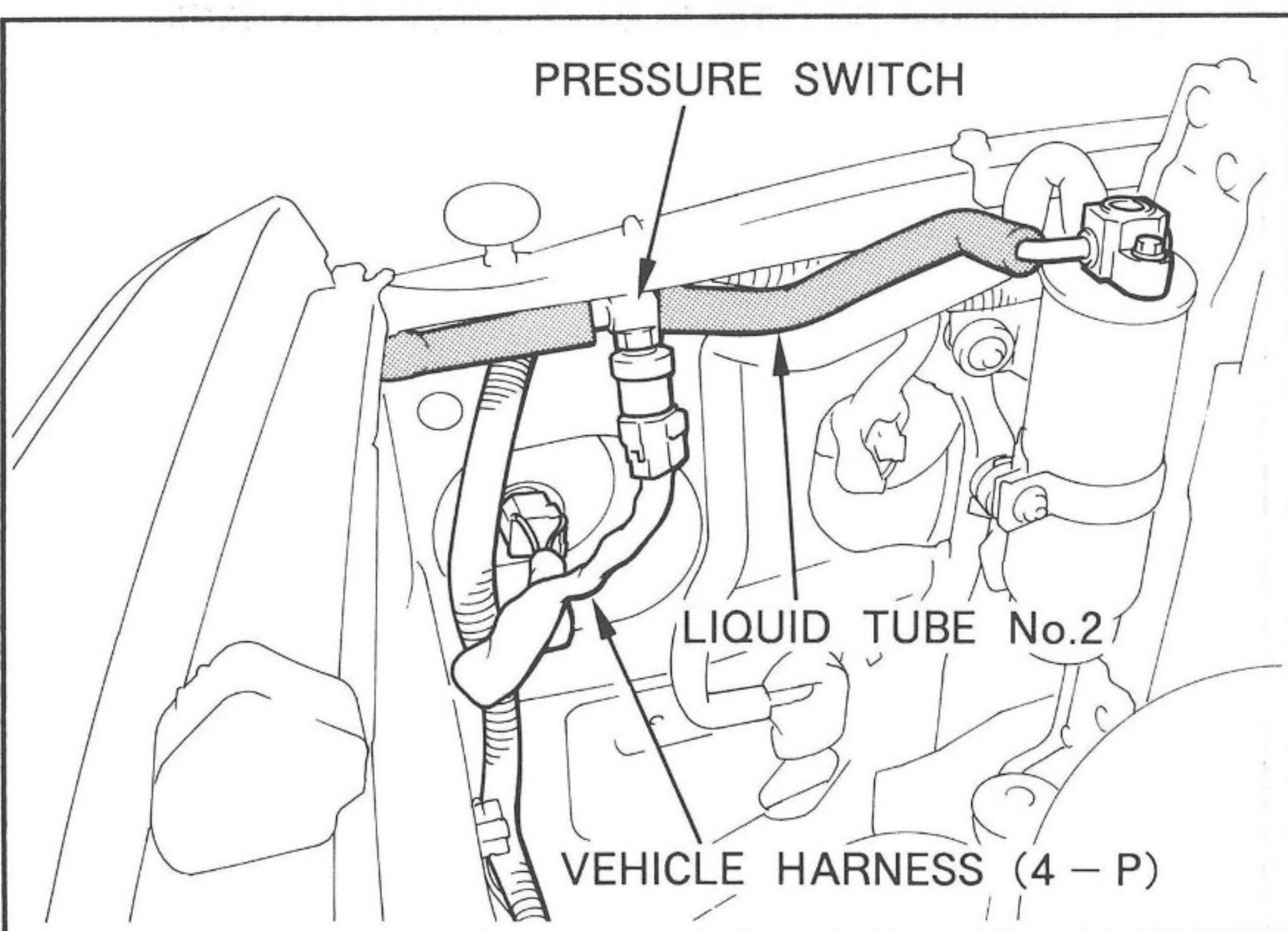

Fig. 38

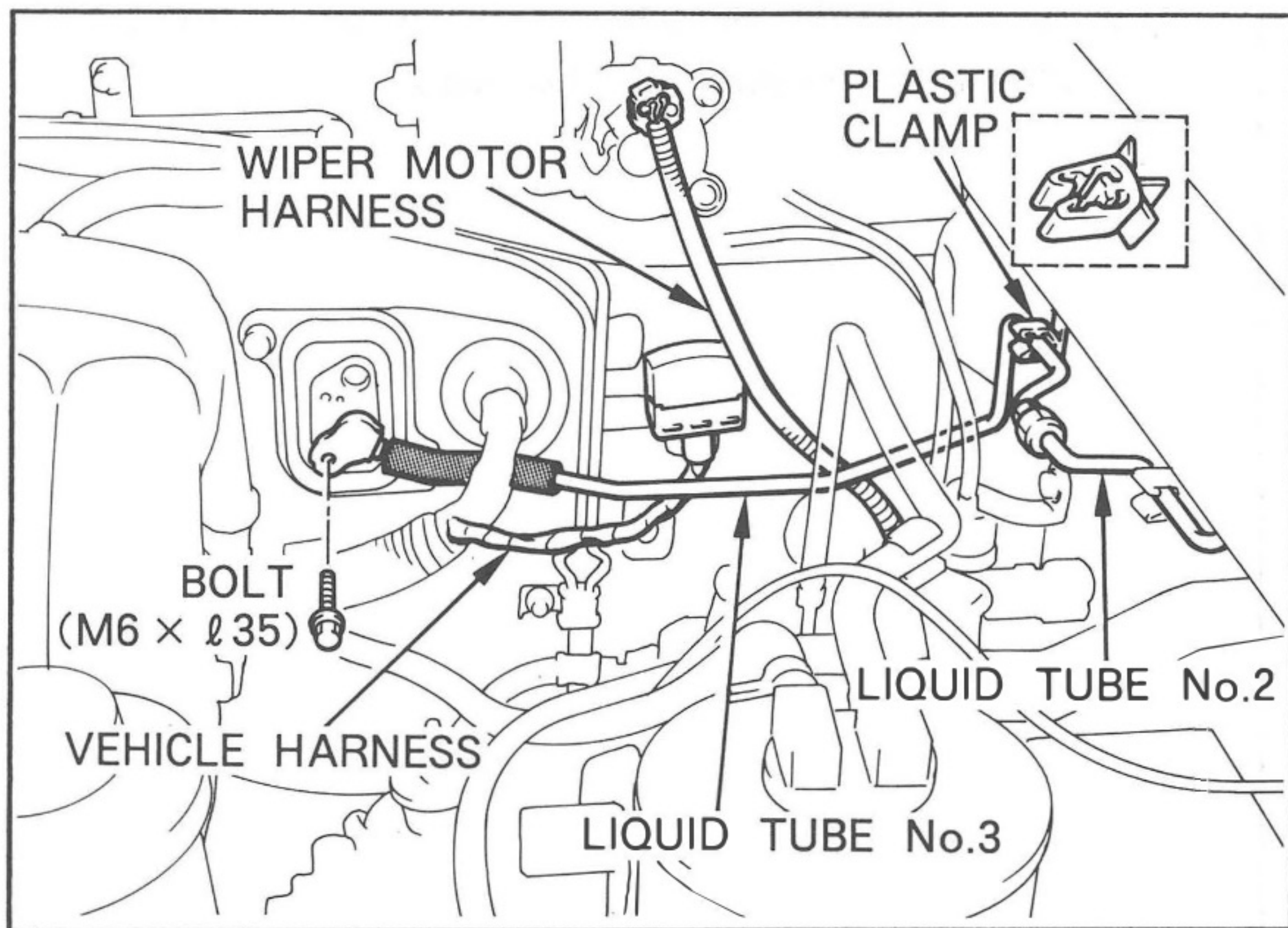

Fig. 39

- (g) Install a plastic clamp to the left side fender.
- (h) Connect the liquid tube No.3 from cooling unit to liquid tube No.2.

Tightening Torque : Cooling unit side
 9.8 N · m (100 kgf · cm, 7.2 ft · lbf)

NOTE

Route the liquid tube(3) beneath the wiper motor harness and vehicle harness.

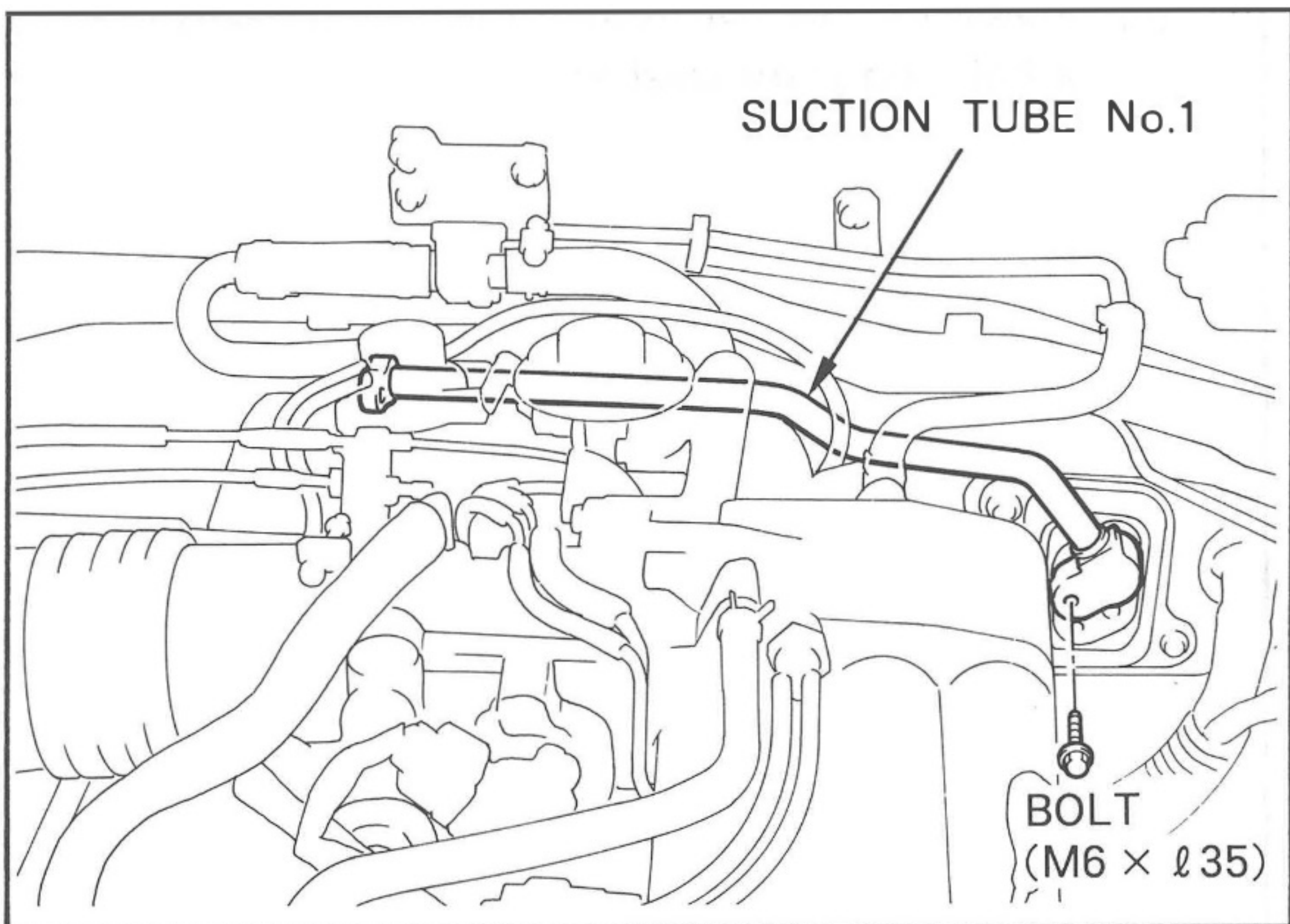

Fig. 40

(8) SUCTION TUBE

- (a) Route the suction tube No.1 between the front heater hose and rear heater hose.
- (b) Connect the suction tube No.1 to the cooling unit using a bolt.

Tightening Torque :
 9.8 N · m (100 kgf · cm, 7.2 ft · lbf)

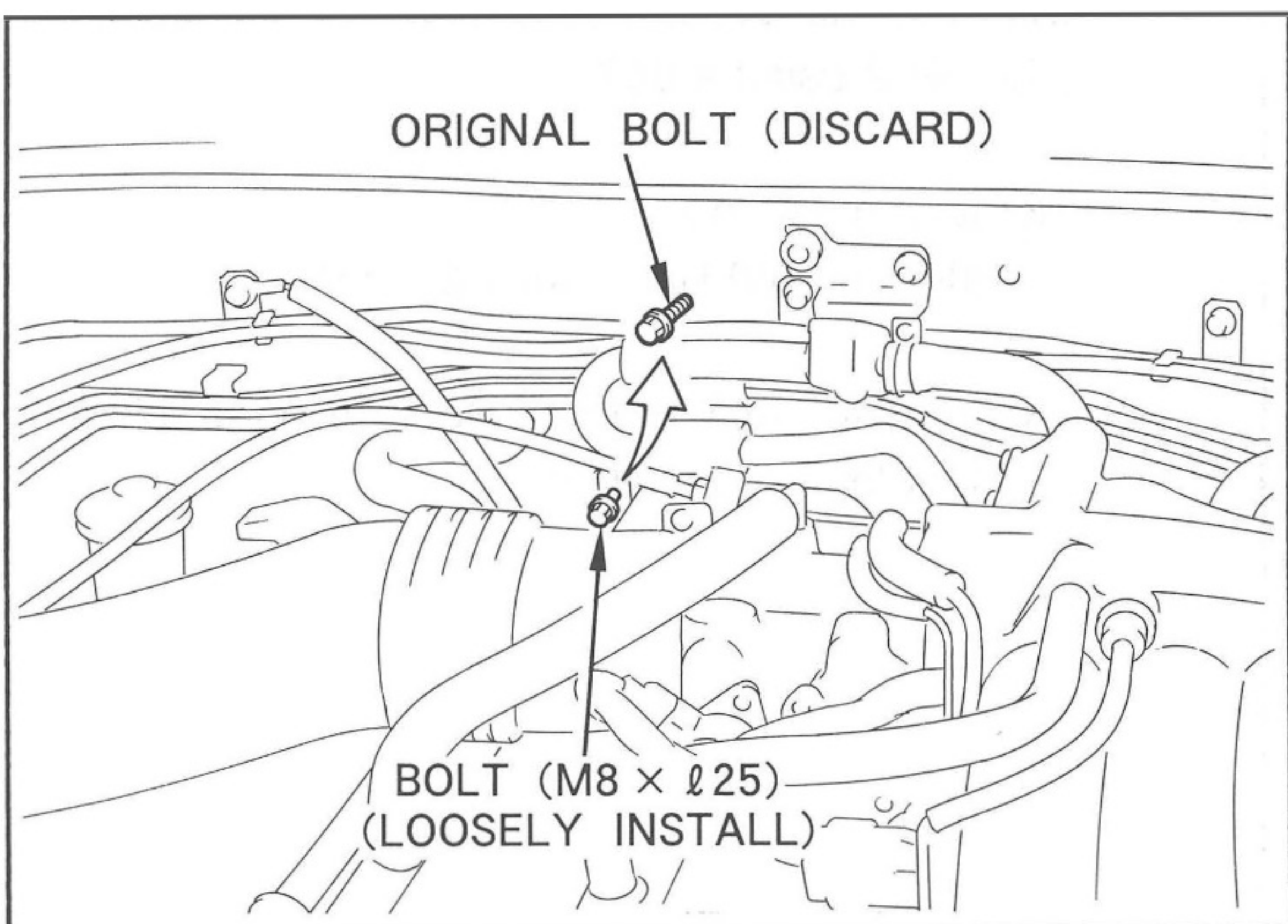

Fig. 41

- (c) Loosely install a bolt instead of the original bolt in bulkhead.

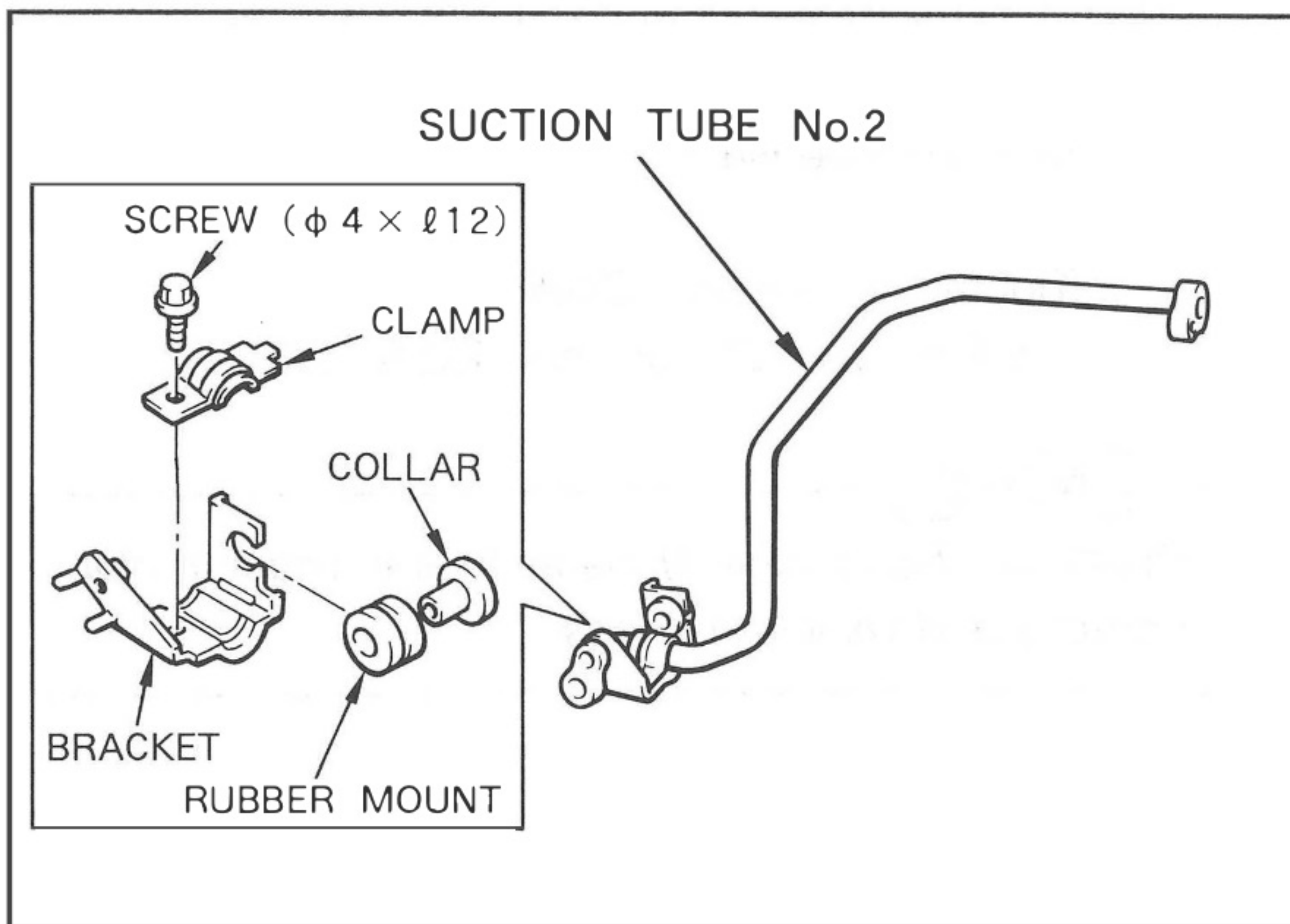

Fig. 42

- (d) Assemble the rubber mount, collar, bracket and clamp to the suction tube No.2.

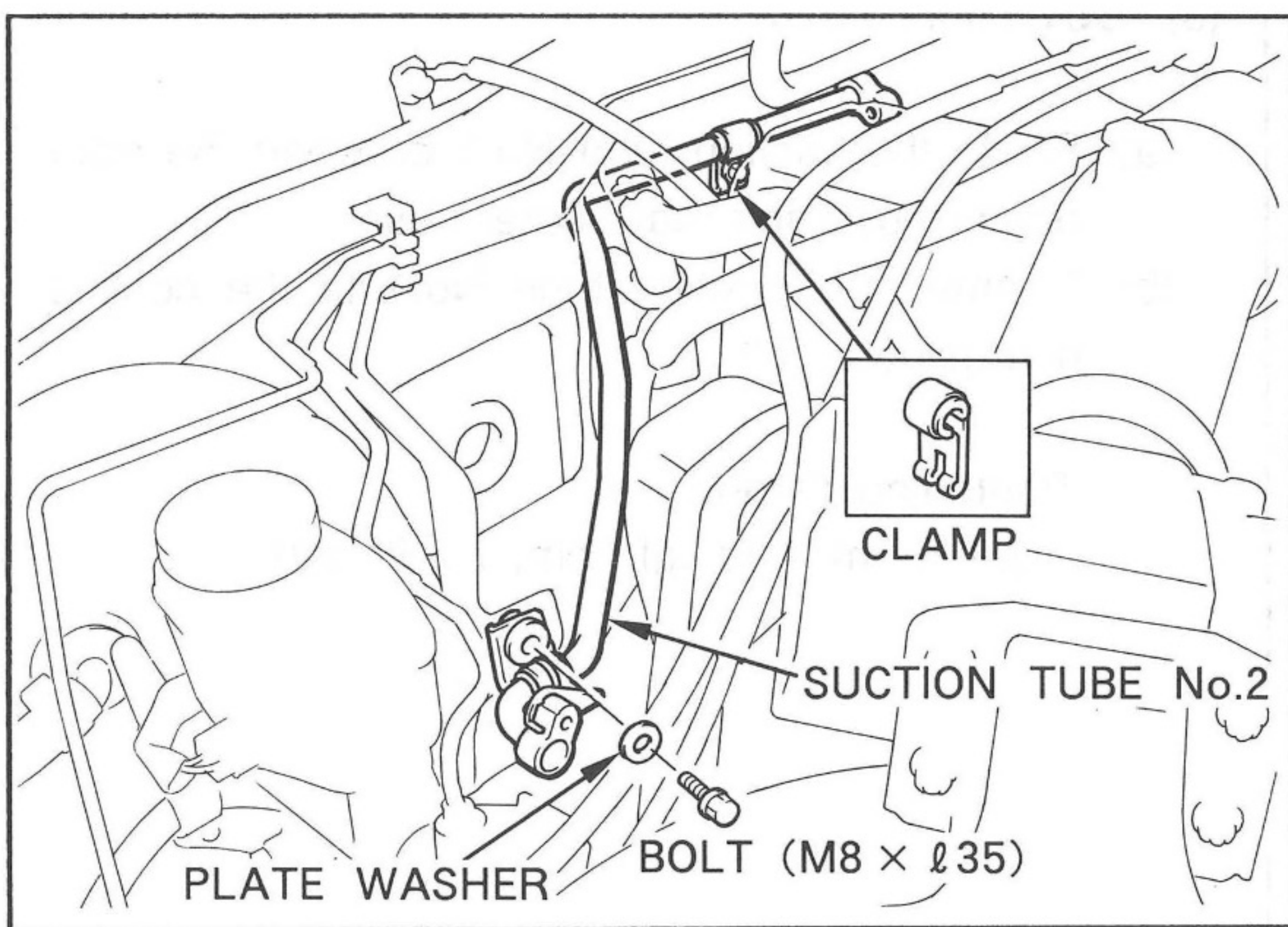

Fig. 43

- (e) Install the suction tube No.2 to the body using a bolt and plate washer.

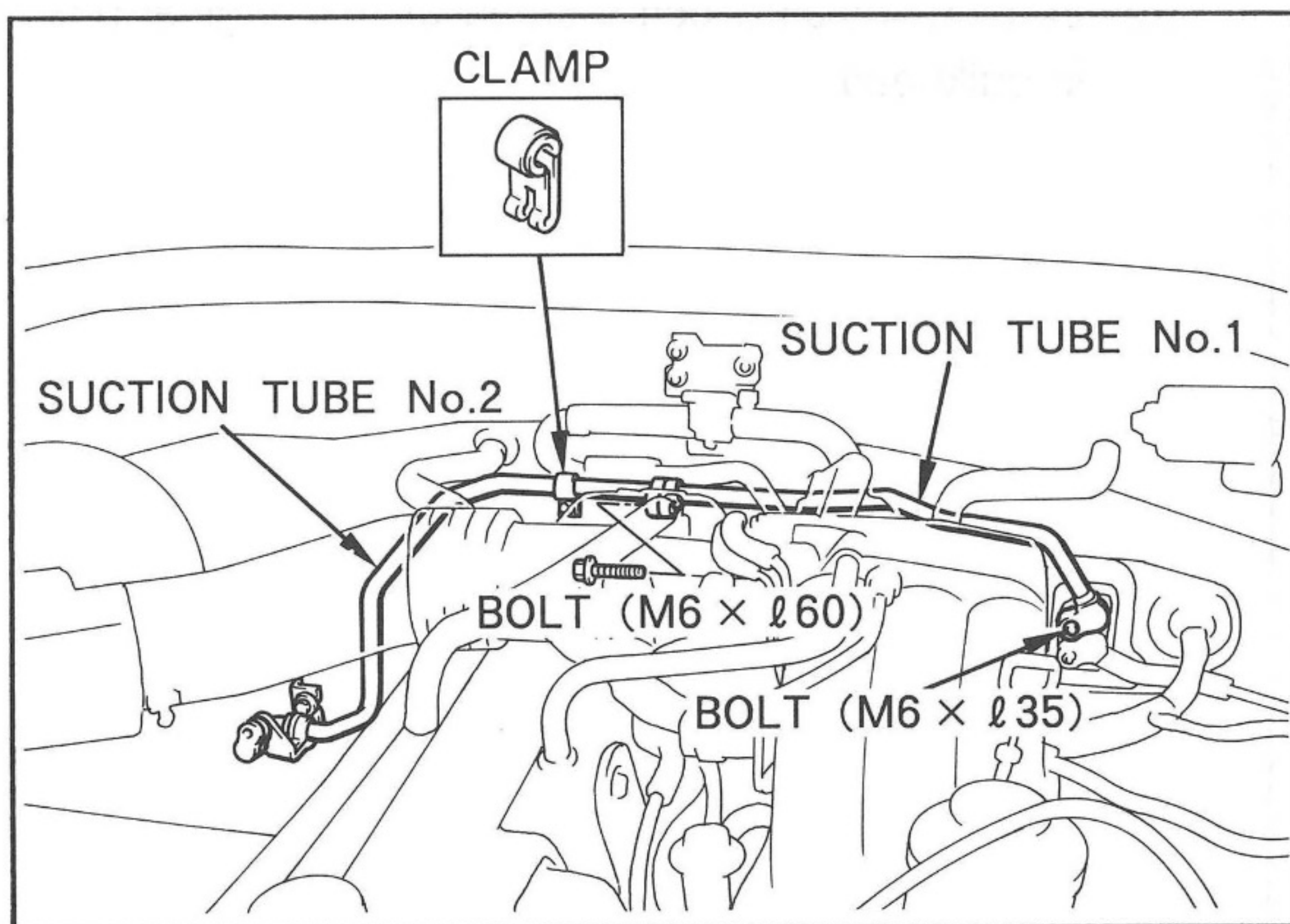

Fig. 44

- (f) Connect the suction tube No.1 to the suction tube No.2 using a bolt.

Tightening Torque :

9.8N · m (100 kgf · cm, 7.2 ft · lbf)

- (g) Fasten the suction tube No.2 using a clamp and bolt loosely installed.

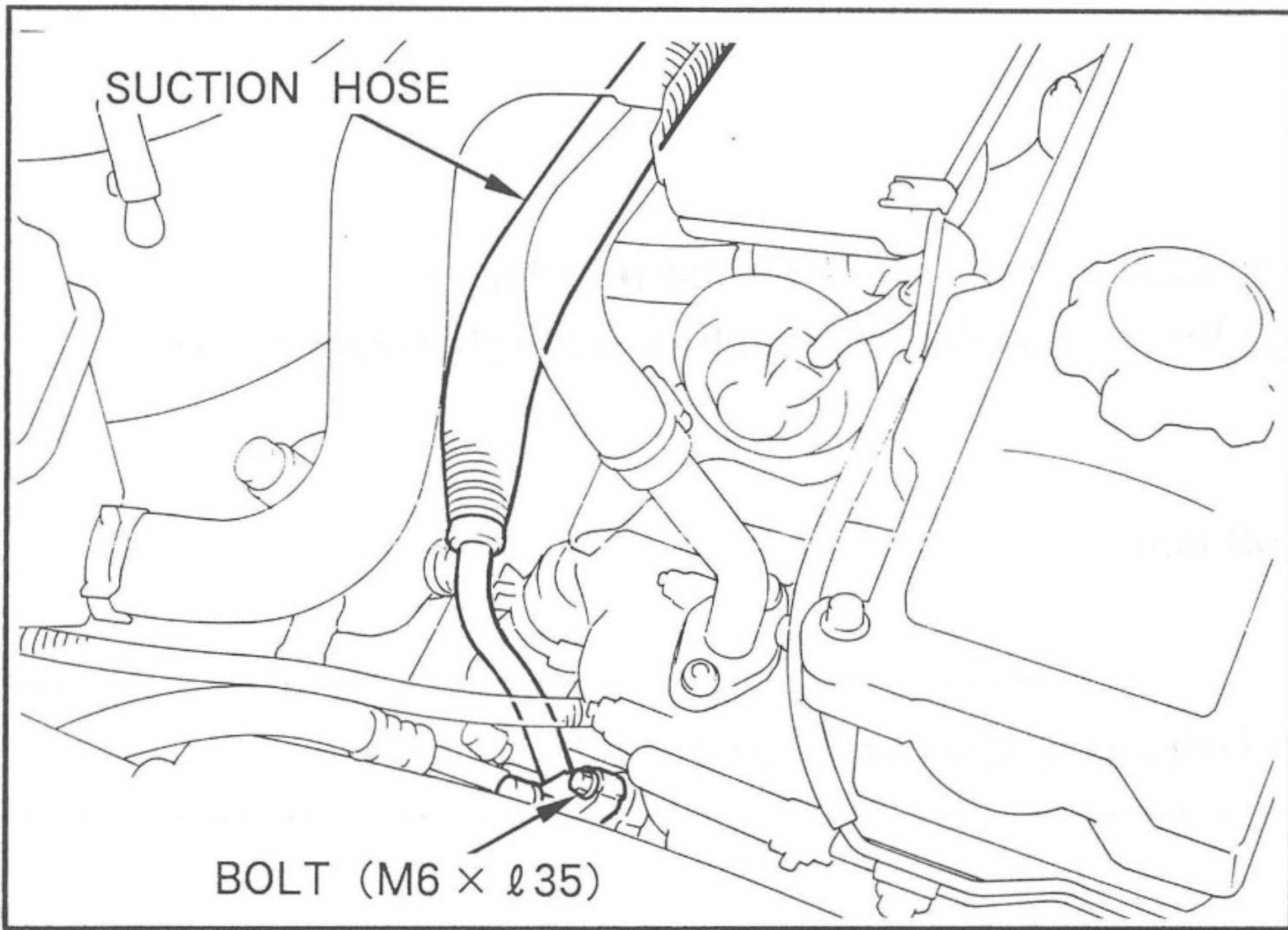

Fig. 45

(9) SUCTION HOSE

- (a) Connect the suction hose to the compressor using a bolt.

Tightening Torque :

9.8 N · m (100 kgf · cm, 7.2 ft · lbf)

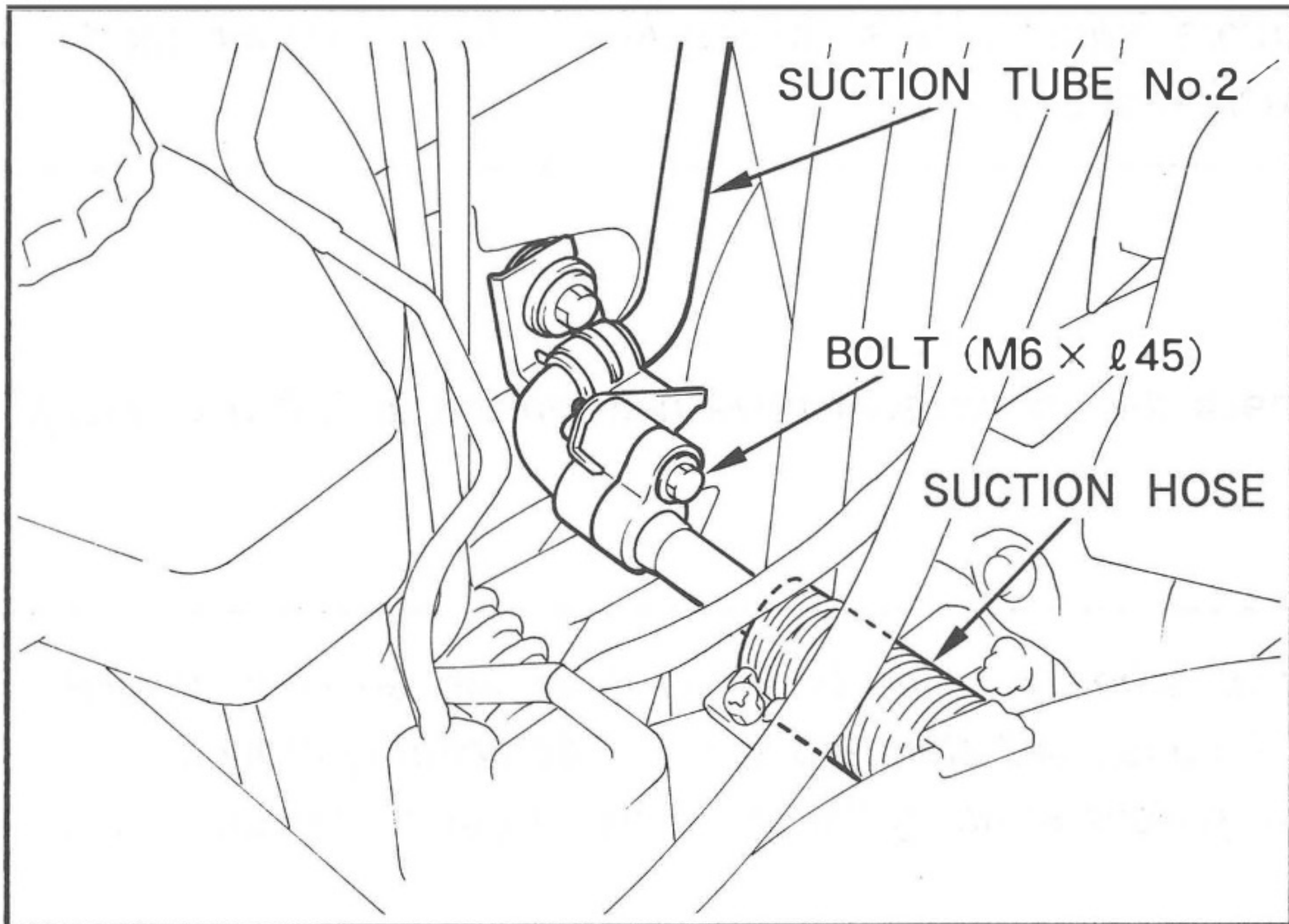

Fig. 46

- (b) Connect the suction hose to the suction tube No.2 using a bolt.

Tightening Torque :

9.8 N · m (100 kgf · cm, 7.2 ft · lbf)

2. FINISH

(1) GENERAL

- (a) After installation is completely finished, all parts temporarily removed should be reinstalled.
- (b) Evacuate the system and check for gas then charge the air conditioning system with refrigerant (Freon R-12) as specified below.

Standard amount of refrigerant : 850-950g (1.87-2.09 lbs)

CAUTION

Never rotate the compressor before charging the air conditioning system with refrigerant.

(2) ADJUSTMENT OF ENGINE REVOLUTION

CAUTION

The engine revolution is controlled by a computer, therefore adjustment is not required. (when the air conditioning system is started, check whether idling revolution increases.)

(3) COMPRESSOR DRIVE BELT ADJUSTMENT

Operate the air conditioner for at least five minutes, check the compressor drive belt tension and, if necessary, adjust as described earlier.

CAUTION

1. *The new compressor drive belt is given extra tension when installed because it will loosen after several minutes running. Recheck that its tension is within the used belt standard specification after operation.*
2. *The belt tension may be measured between any two pulleys in using the belt tension gauge. Tension must be adjusted to the middle of the standard values.*

(4) FINAL INSPECTION

Check it :

- 1) All heater and air conditioner controls operate correctly.
- 2) All vehicle functions operate correctly.
- 3) Any abnormal noises are heard when the air conditioner is operating.

The air conditioner is now ready for use.

Be sure to explain its operation to the owner.

3. A/C AMPLIFIER

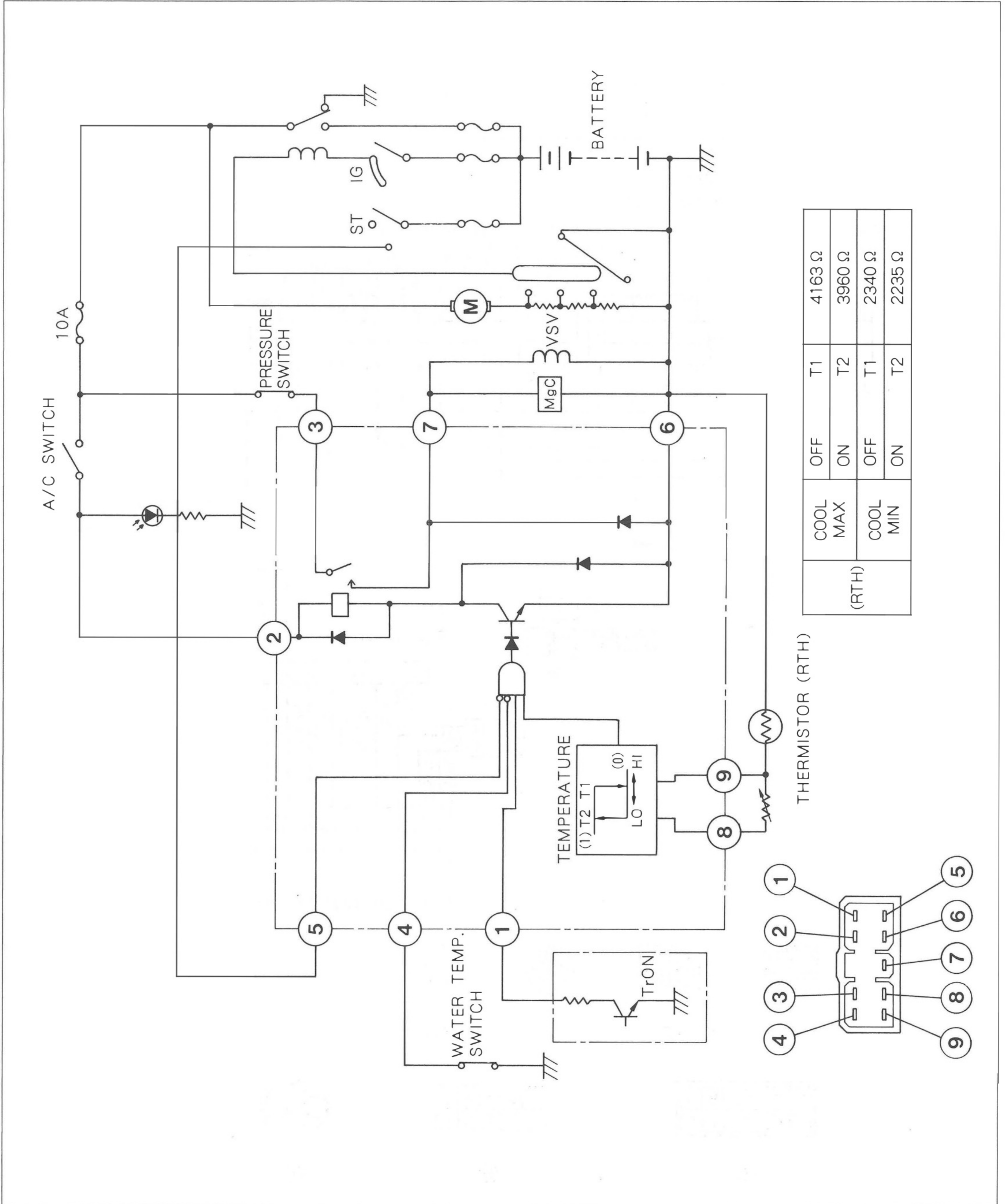

(RTH)	COOL MAX	OFF	T1	4163 Ω
	COOL MIN	ON	T2	3960 Ω
		OFF	T1	2340 Ω
	ON	T2	2235 Ω	

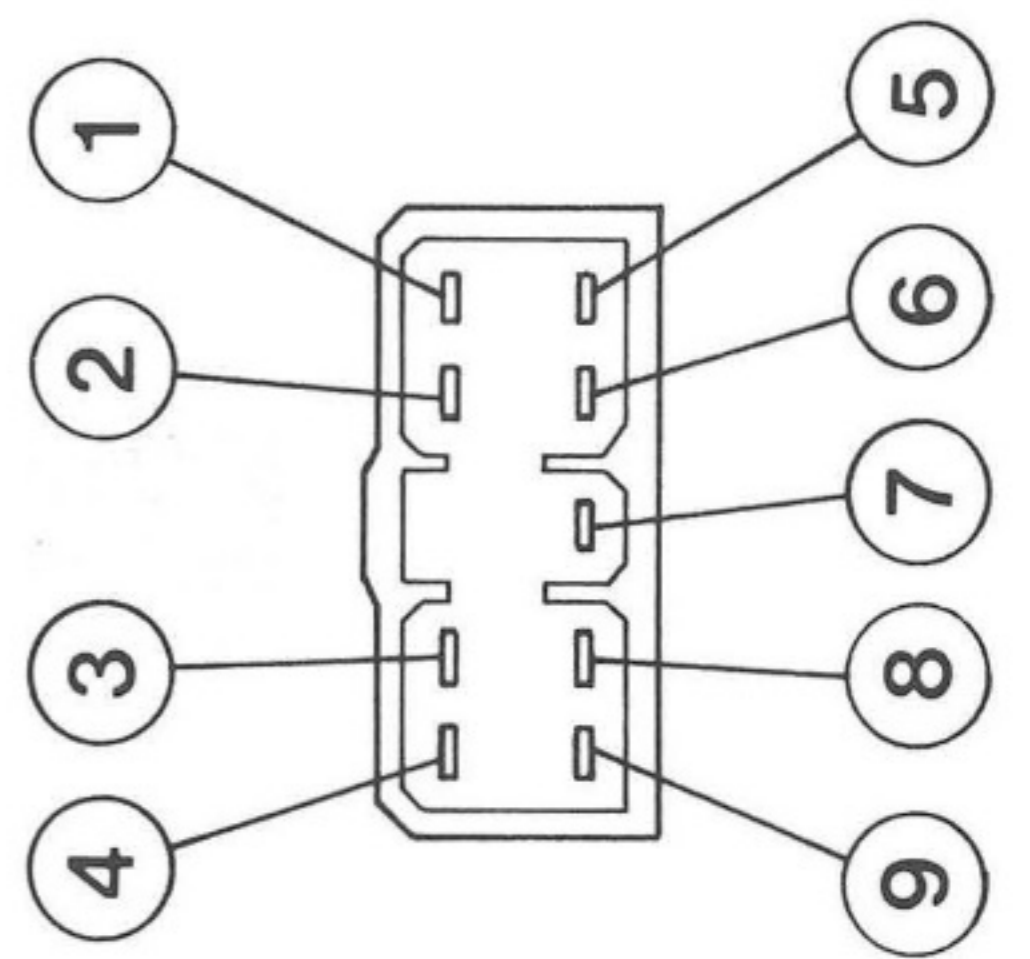

4. WIRING DIAGRAM

