

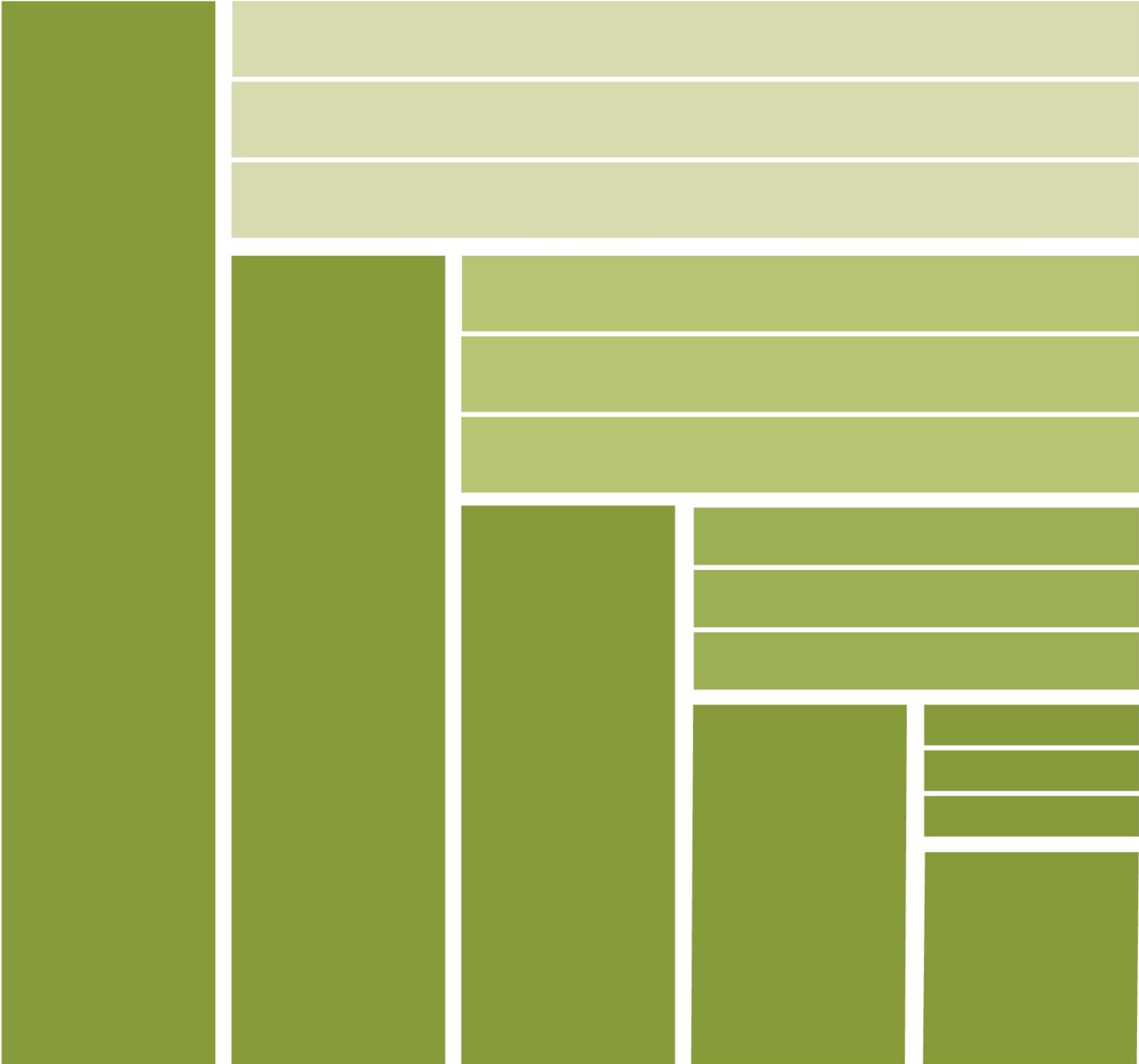

# TOYOTA HIACE AIR CONDITIONER

HZJ80R, HDJ80R, FJ80R

## INSTALLATION MANUAL



© 1990 NIPPONDENSO CO.,LTD.

All Rights Reserved. This book, parts thereof, may not be reproduced or copied in any form without the written permission of the publisher.

## FOREWORD

This manual has been published to explain how to install the air conditioner in the TOYOTA LANDCRUISER HZJ80R (1HZ E/G), HDJ80R (1HD-T E/G), FJ80R (3F, 3F-E E/G).

Care should be taken to install the air conditioner as described in this manual.

It is recommended that this manual be kept readily available for reference at all time. We reserve the right to make changes in this manual, at any time, without notice.

## TABLE OF CONTENTS

	PAGE
<b>GENERAL INFORMATION</b> .....	<b>1</b>
<b>1. INSTALLATION</b>	
<b>1.1 INSTALLATION : PASSENGER COMPARTMENT</b> .....	<b>5</b>
<b>1.2 INSTALLATION : ENGINE COMPARTMENT</b>	
■ <b>1HZ, 1HD-T ENGINE MODEL</b> .....	<b>15</b>
<b>1.3 INSTALLATION : ENGINE COMPARTMENT</b>	
■ <b>3F, 3F-E ENGINE MODEL</b> .....	<b>33</b>
<b>2. FINISH</b> .....	<b>55</b>
<b>3. WIRING DIAGRAM</b> .....	<b>57</b>
<b>4. AMPLIFIER CIRCUIT</b> .....	<b>60</b>

## GENERAL INFORMATION

### 1. PREPARATIONS BEFORE INSTALLATION

#### (1) Vehicle Inspection and Adjustment

Prior to installing the air conditioner, make the following inspections and/or adjustments.

- (a) Engine Ignition Timing (Engine Injection Timing)
- (b) Engine Cooling System
- (c) Battery Electrolyte and Charging System
- (d) Fuel System
- (e) General Vehicle Inspection

#### (2) Preparations of Air Conditioner Parts

Unpacking the kit, lay all parts out in order of installation.

Check entire contents of the kit for missing or defective components.

Installing the air conditioner, use guard covers and seat covers for protection.

#### (3) Installation Tools

- (a) Vacuum Pump
- (b) Air Conditioner Service Tools
- (c) Torque Wrench
- (d) Hand Service Tools

### 2. SERVICE PRECAUTIONS

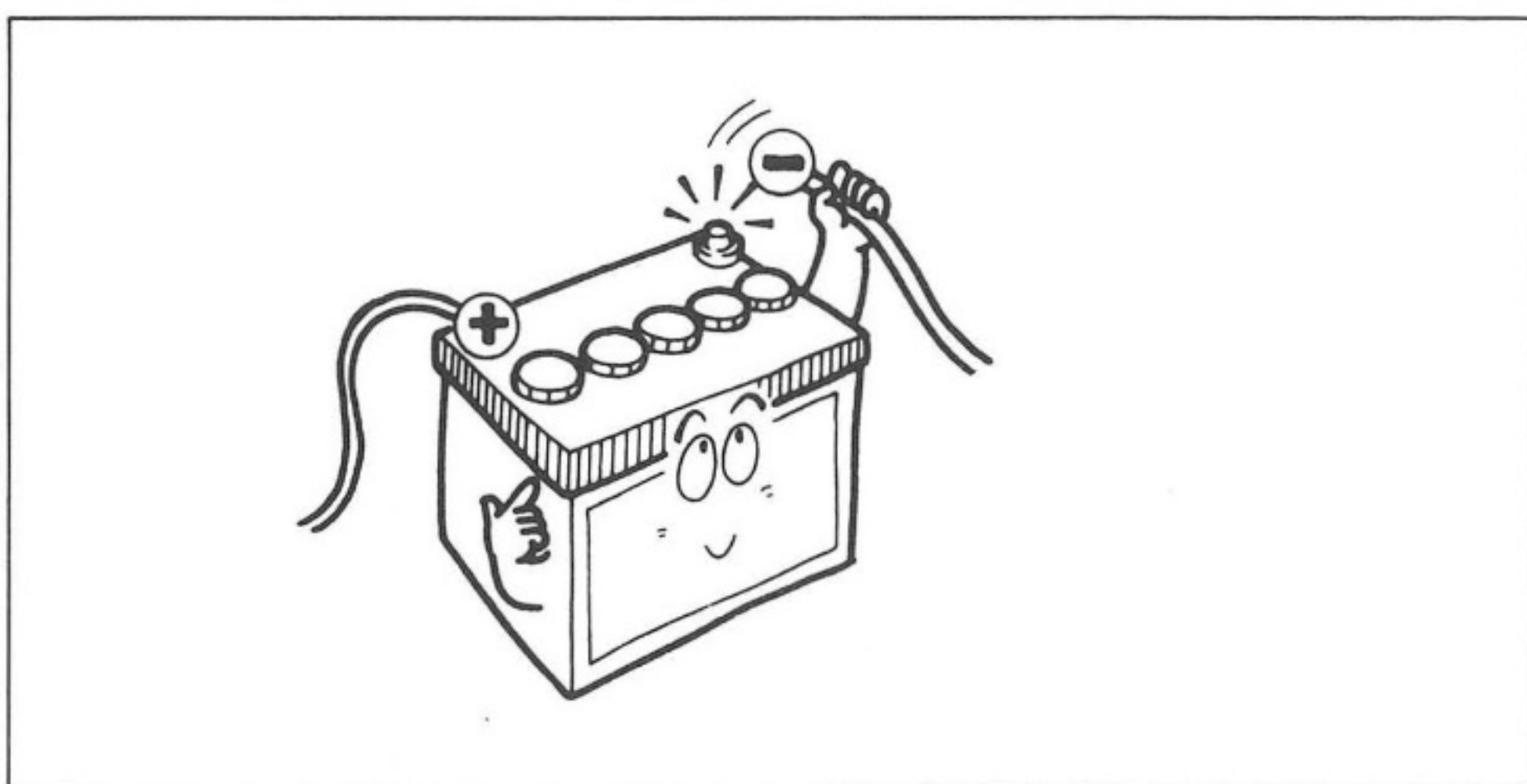

- (1) Disconnect the ground cable at the battery negative terminal.

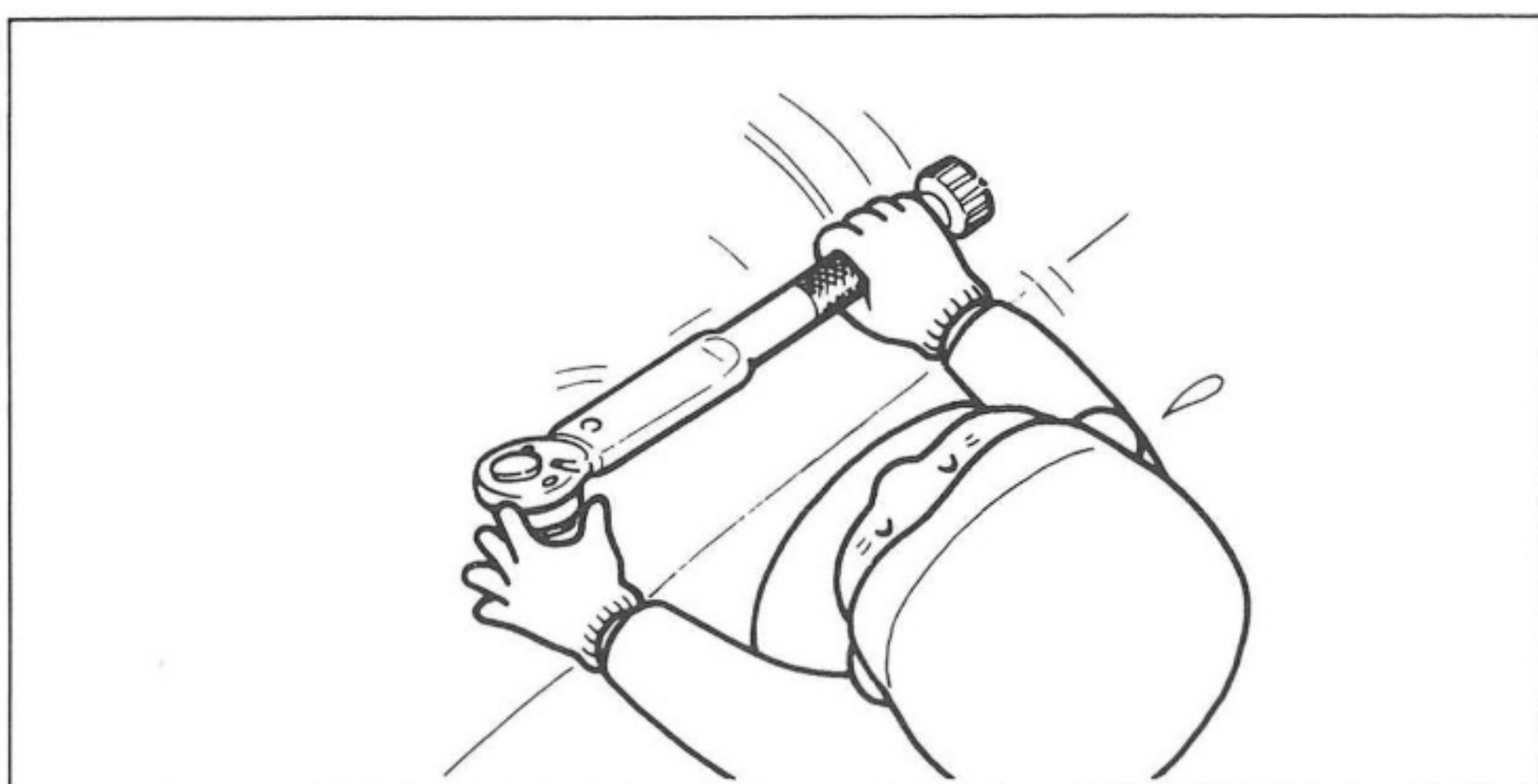

- (2) Parts mounted on the engine must use bolts provided in the kit and be torqued to specifications.

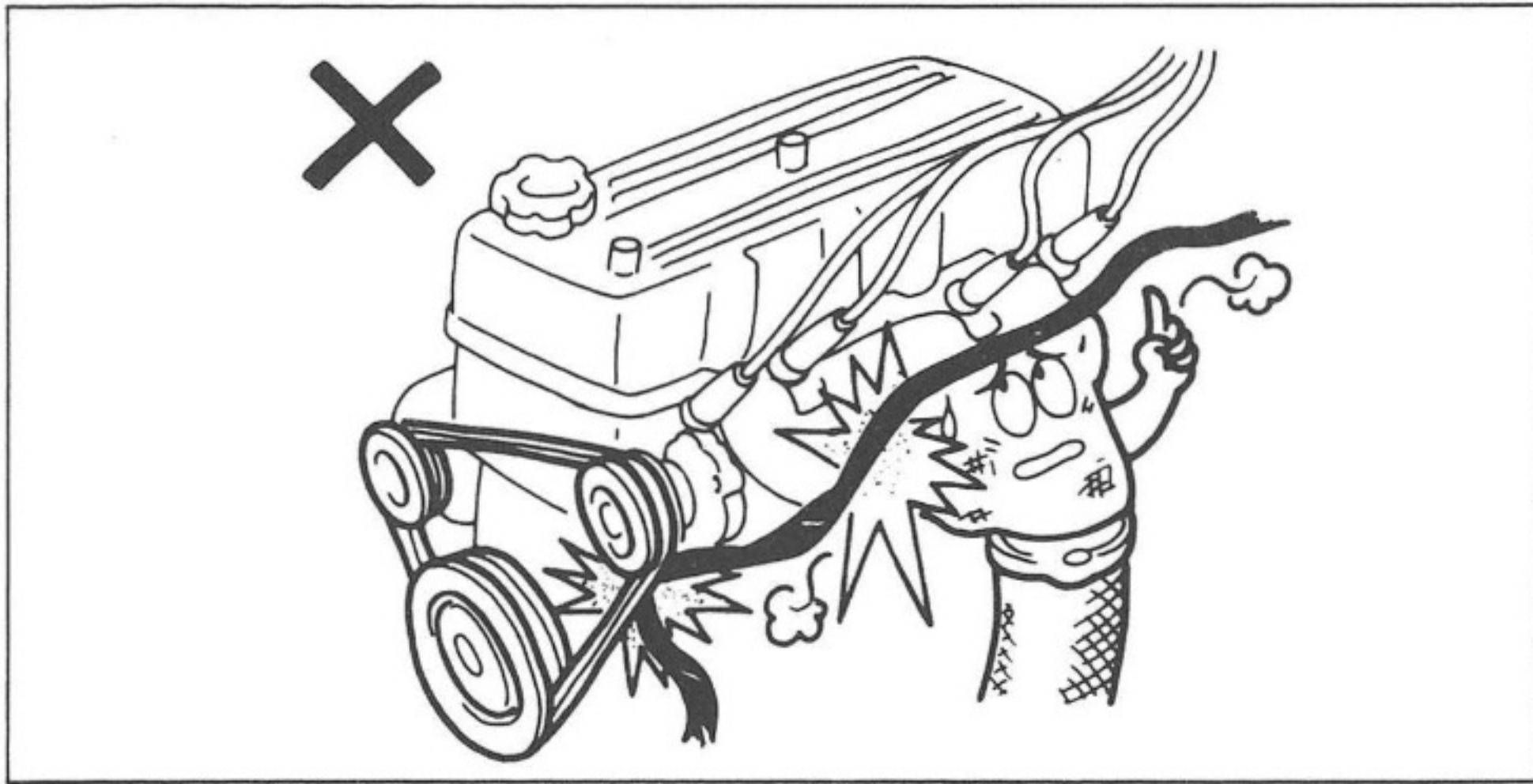

(3) Installing air conditioning lines and A/C harnesses, route properly to avoid interference with surrounding parts.

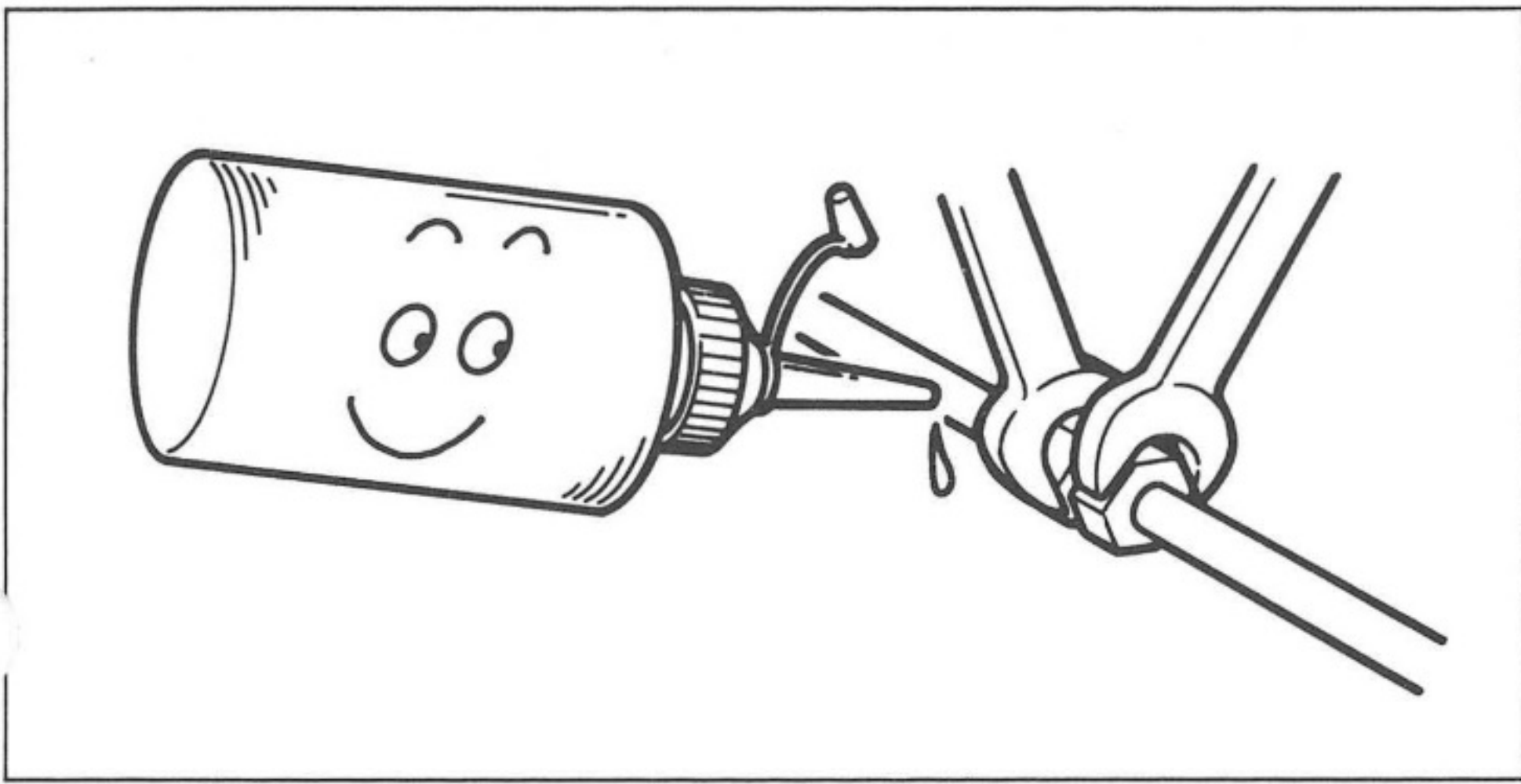

(4) Before making any hose and tube connections, apply a few drops of refrigeration oil to the seat of O-ring.

(5) Tightening or loosening line fittings, use two wrenches to prevent the pipes from twisting.

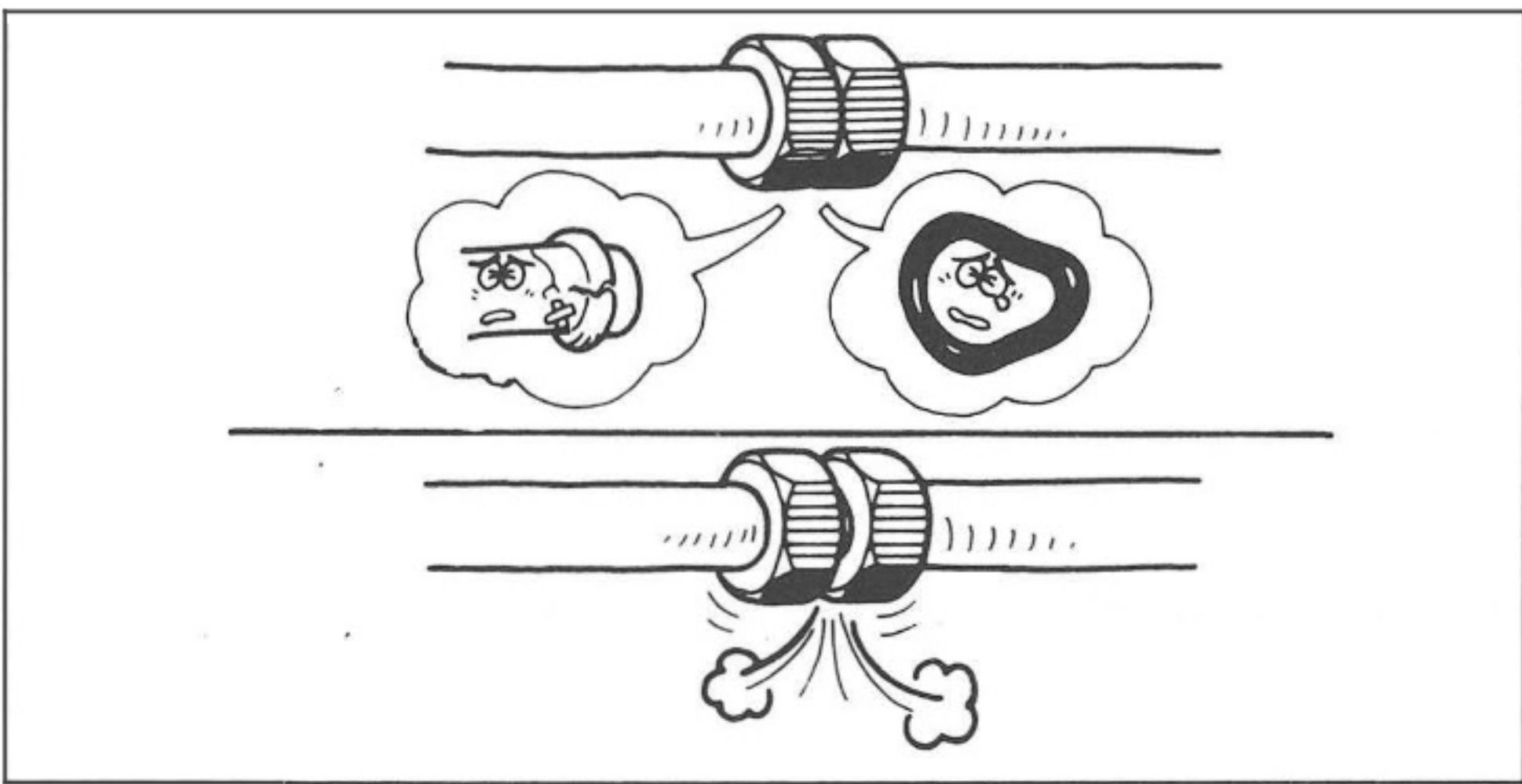

(6) Tighten coupling nuts according to specified torque.

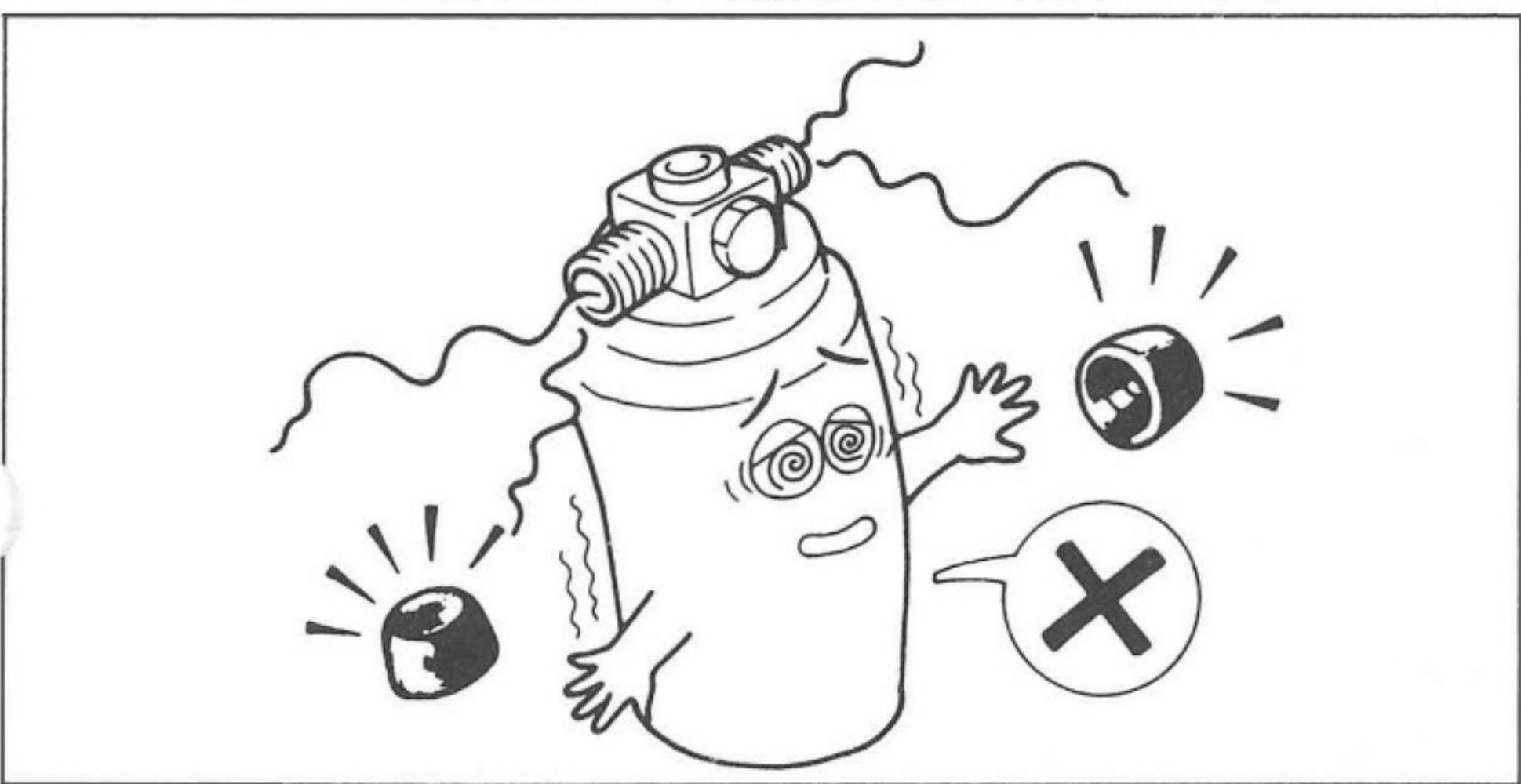

(7) Do not remove caps from fittings until each component is ready for connection.

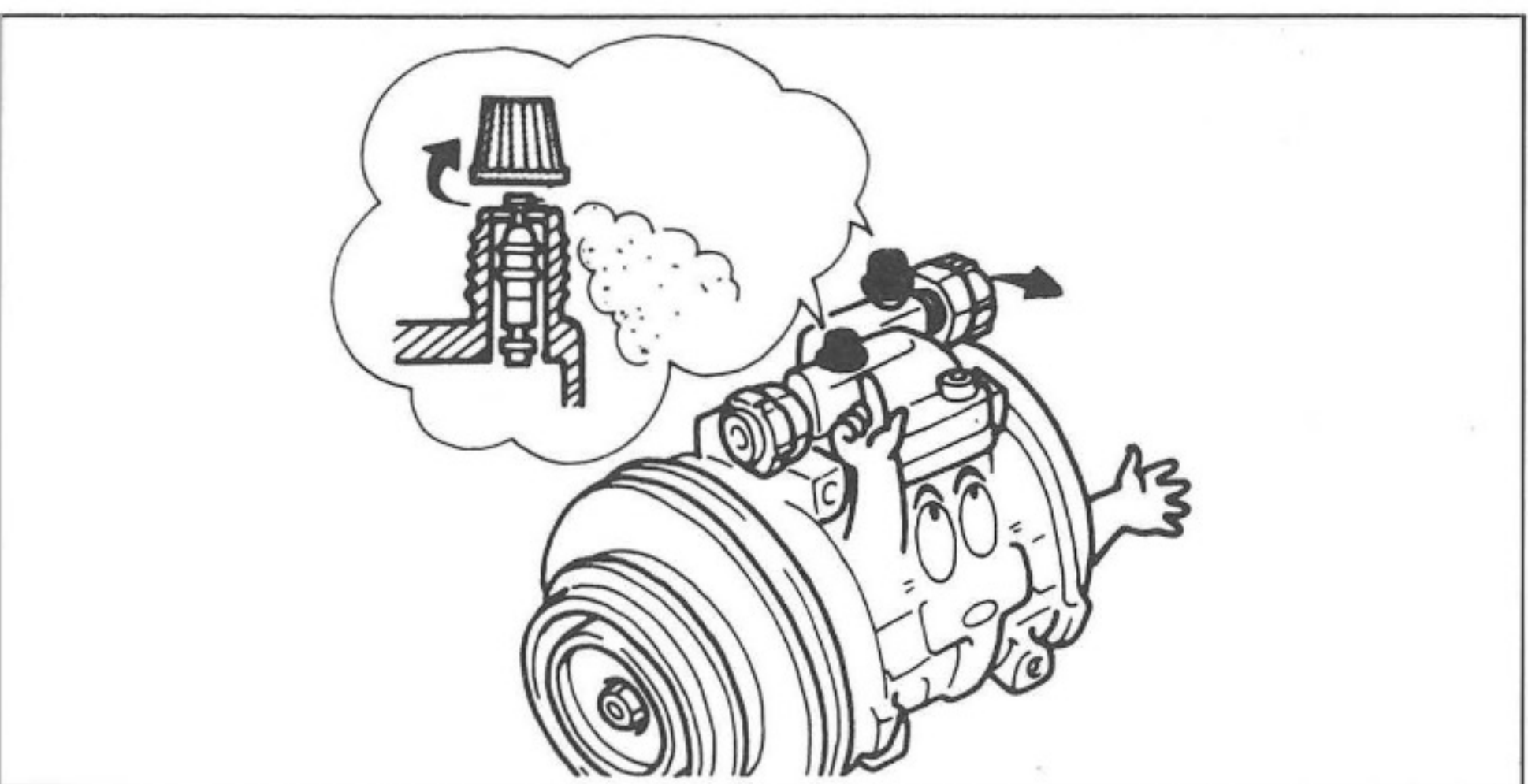

**CAUTION**

*Remove caps from compressor slowly to allow nitrogen gas to escape. The compressor is shipped from the factory with a slight charge of gas to prevent corrosion of seals.*



- (8) Handling the refrigerant R-12, wear eye protection and be careful that liquid refrigerant does not contact skin.

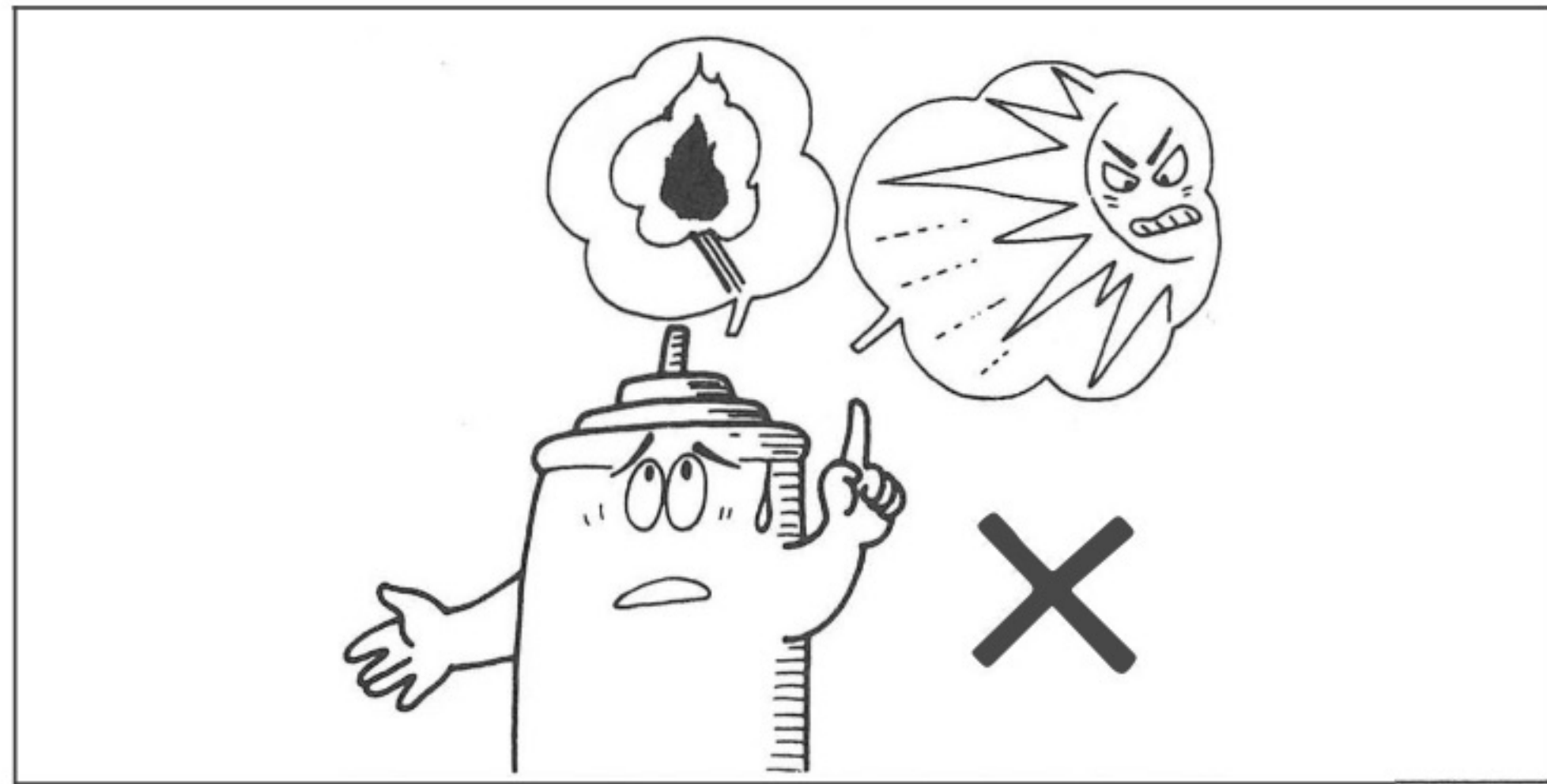

- (9) Keep the refrigerant container (service drum) below 40°C (100 °F). Follow manufacturer's instruction.

### 3. WHEN INSTALLING

- (1) All instructions are given from the driver's point of view.
- (2) Figures in parentheses indicate diameter and length of bolt stem.

Example: (a) **BOLT** (M6× $\varnothing$  16) means a hex head bolt which has 6mm thread diameter and 16mm in stem length.

(b) **SCREW** or **TAPPING SCREW** ( $\varnothing$ 6× $\varnothing$  16) means a round head screw which has a 6mm thread diameter and a 16mm-stem.

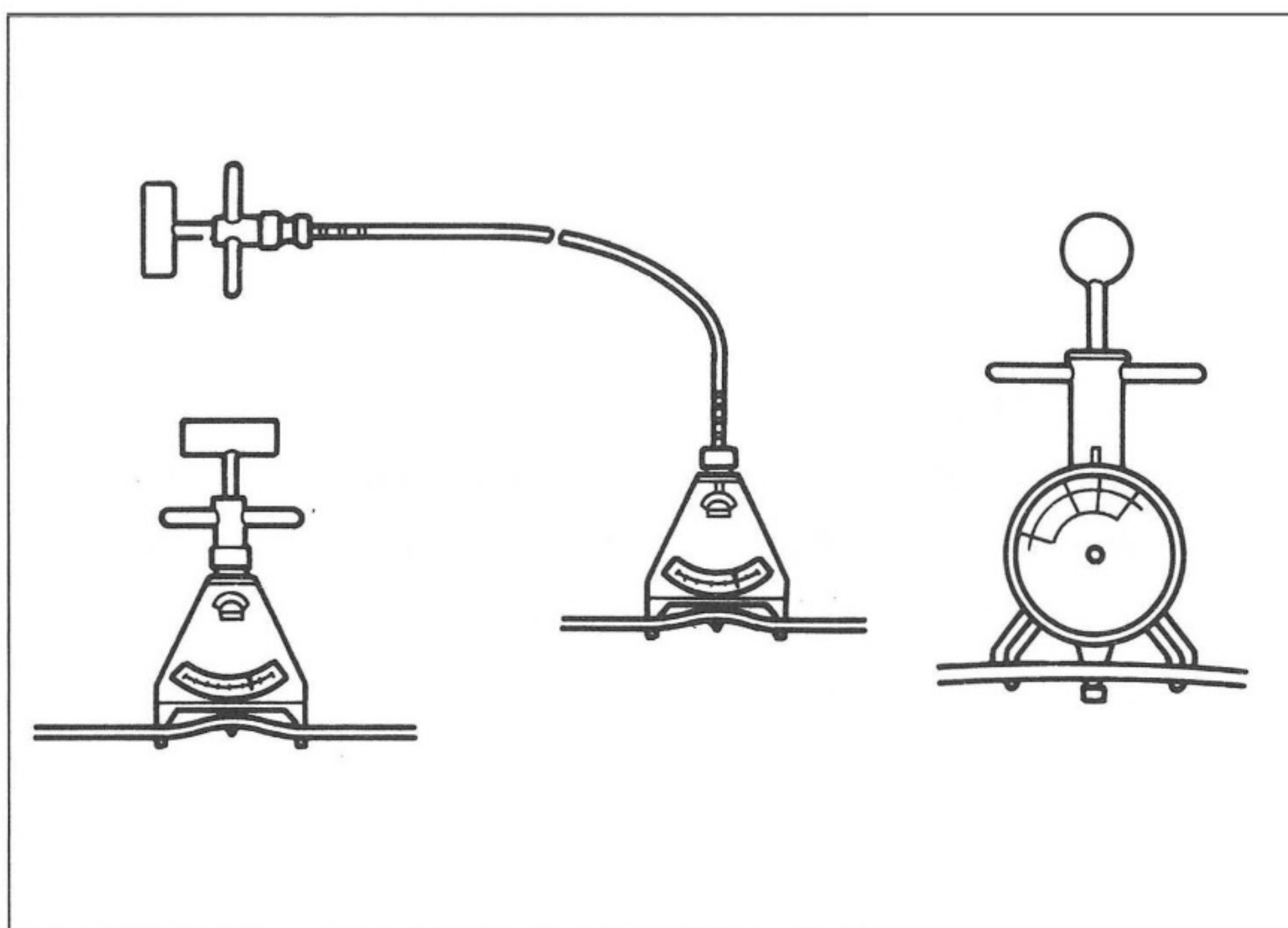

- (3) Installing the drive belt, check the belt tension using NIPPONDENSO BTG-20 or BURROUGHS BT-33-73F.

#### NOTE

- 1) "New belt" refers to a belt which has been used less than 5 minutes (poly-V-ribbed) or 15 minutes (non poly-V-ribbed) on a running engine.
- 2) "Used belt" refers to a belt which has been used on a running engine for 5 minutes or more.

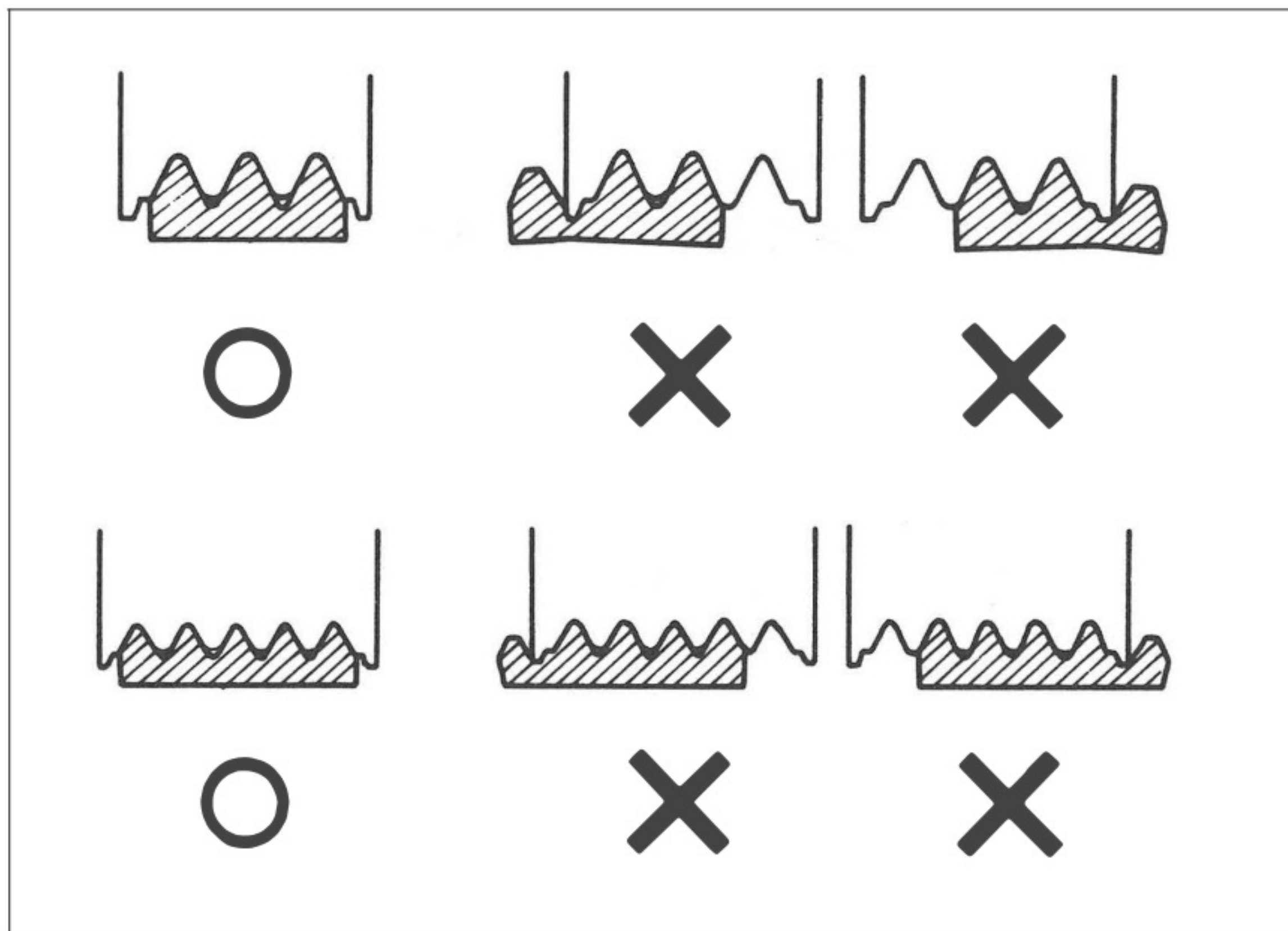

**CAUTION**

- 1) *The V-ribbed belt requires accurate tension adjustment ; weak tension is likely to cause the belt whine, while excessive tension may result in damage to the bearings in the alternator, idle pulley and the compressor.*
- 2) *After installing the drive belt, check that it fits properly in the ribbed grooves.*

(4) TIGHTENING TORQUE

UNIT: kg-cm <Nm> (ft-lbs)

Dia. × Pitch	4T BOLT	6T BOLT	8T BOLT
M6 × 1.0	55 <5.0> (4.0)	80 <8.0> (5.8)	—
M8 × 1.25	130 <12.5> (9.4)	195 <19.0> (14.1)	300 <29.0> (21.7)
M10 × 1.25	260 <26.0> (18.8)	400 <39.0> (29.0)	620 <61.0> (44.9)
M12 × 1.25	480 <47.0> (34.8)	730 <71.0> (52.8)	1100 <110.0> (79.6)

# 1. INSTALLATION

## 1.1 INSTALLATION : PASSENGER COMPARTMENT

### (1) REMOVAL OF PARTS

\* Before installing the air conditioner, the following parts should be removed.

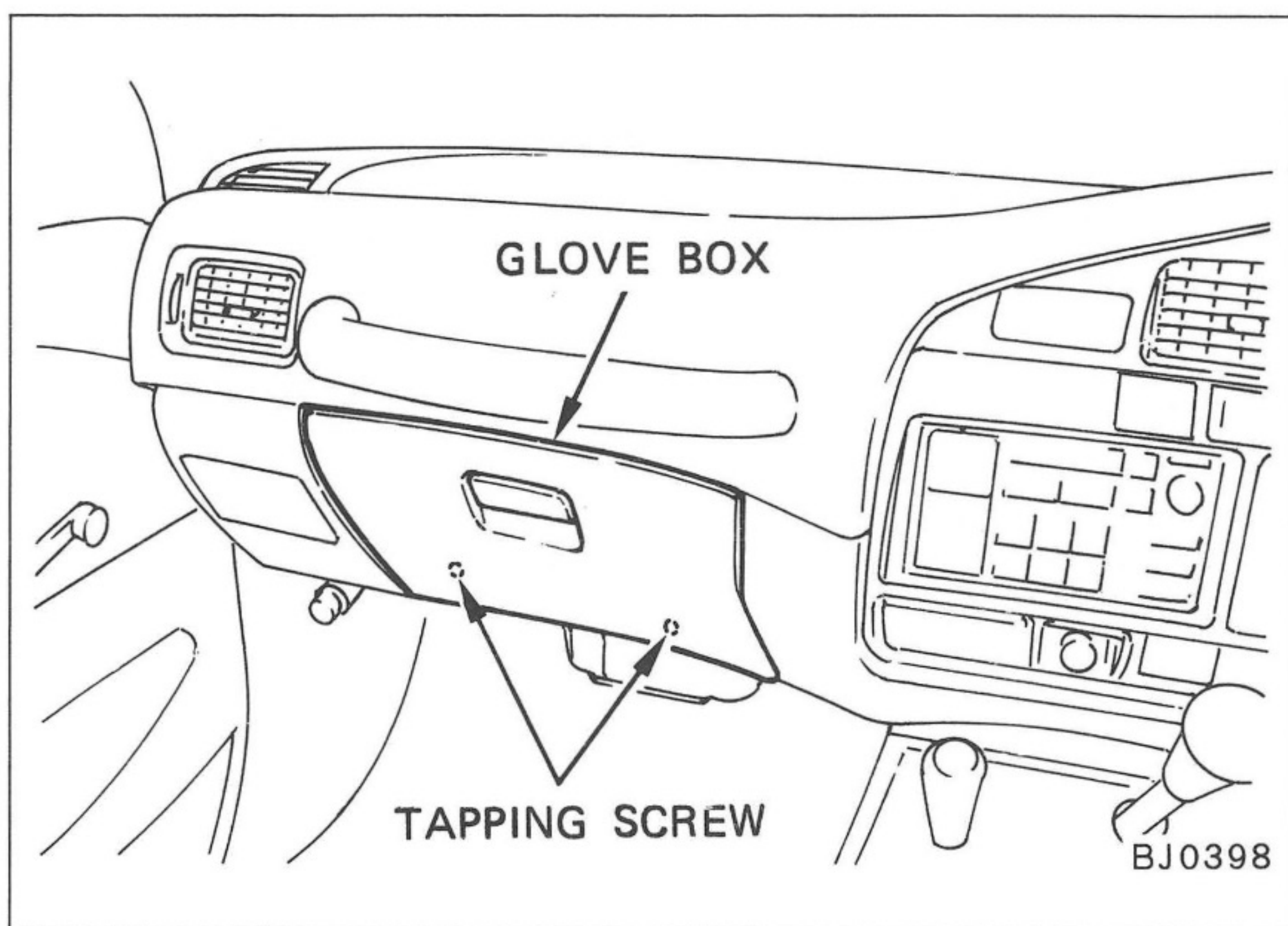

Fig. 1

(a) Glove box

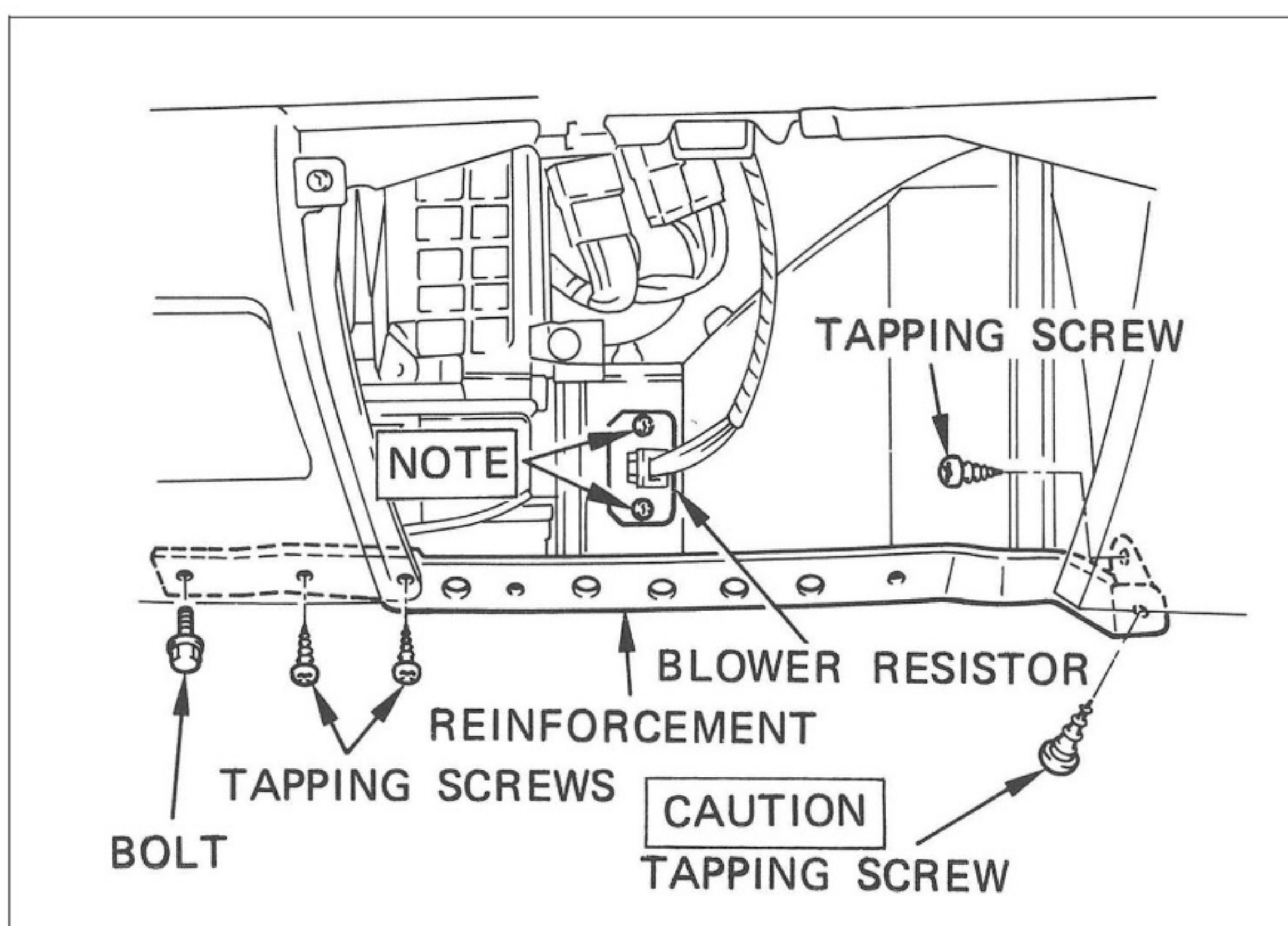

Fig. 2

(b) Reinforcement

#### CAUTION

Ensure that the tapping screw on the far right hand side is removed.

(c) Blower resistor

#### NOTE

Do not discard the two tapping screws for the blower resistor.

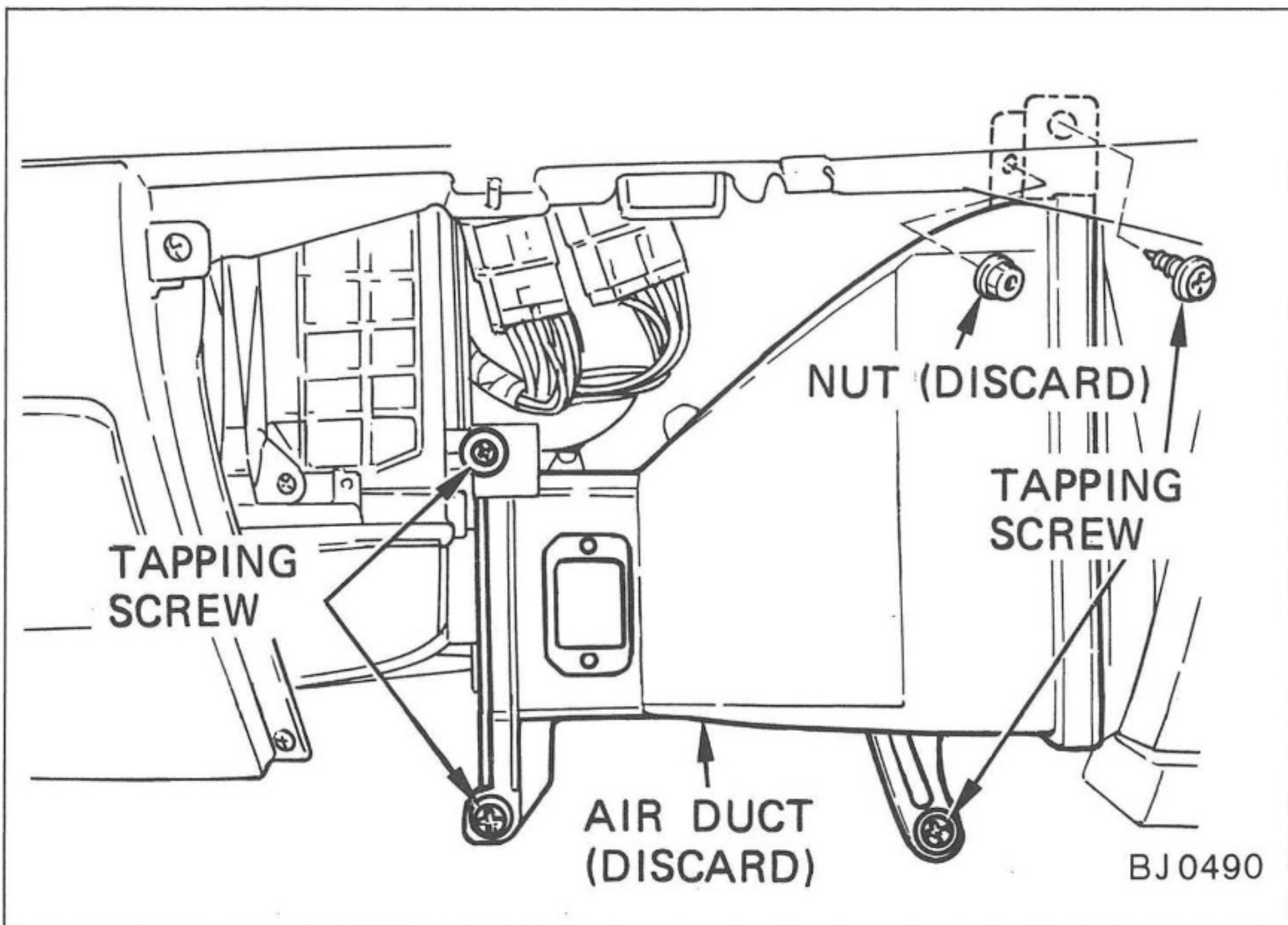

Fig. 3

(d) Air duct .....Discard

**NOTE**

Keep four original tapping screws.

(e) Nut .....Discard

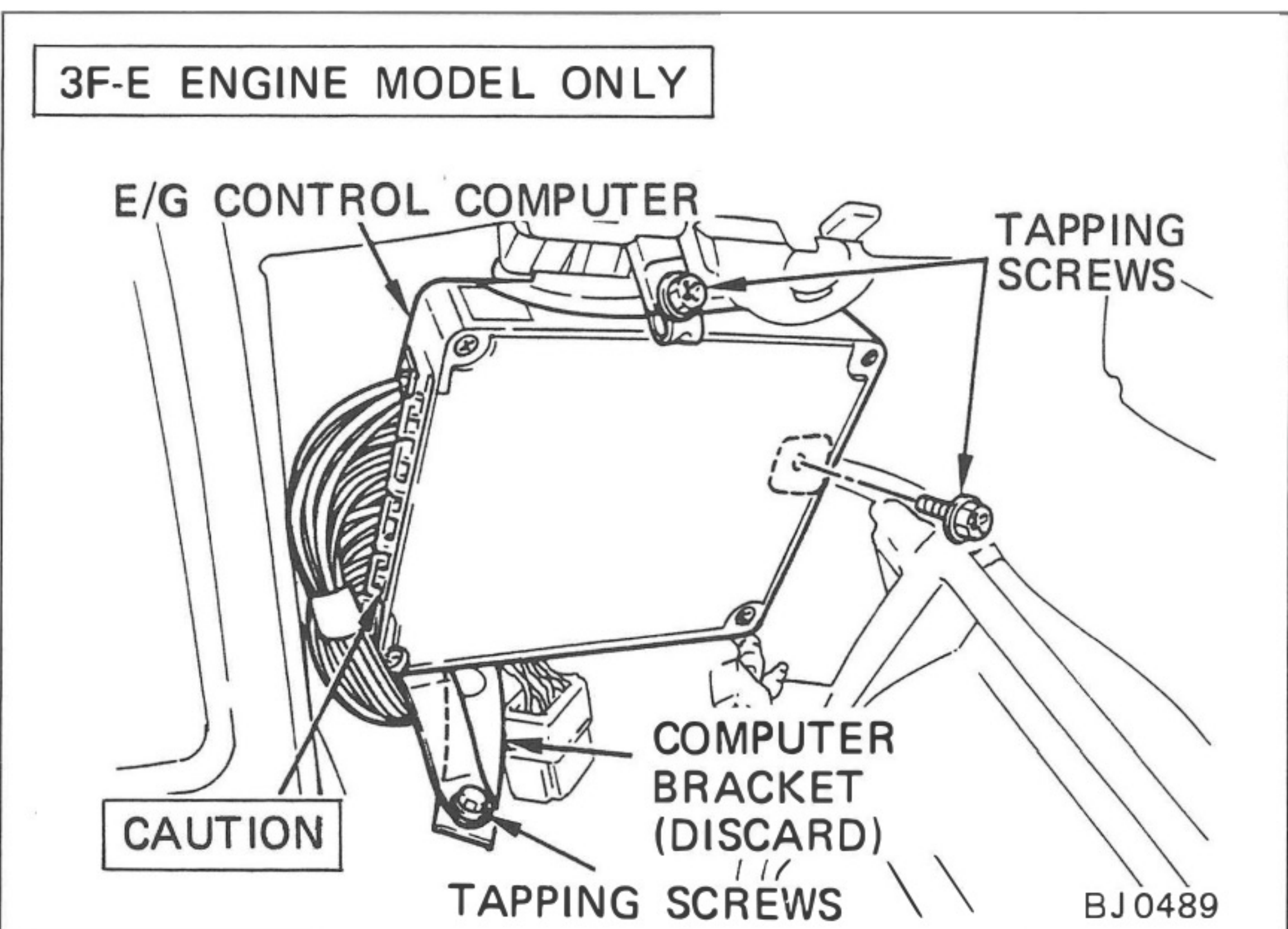

Fig. 4

■ 3F-E ENGINE MODEL ONLY

(f) Engine control computer.

**CAUTION**

Do not disconnect the vehicle harness from engine control computer.

(g) Engine control computer bracket .....Discard

**NOTE**

Do not discard three original tapping screws.

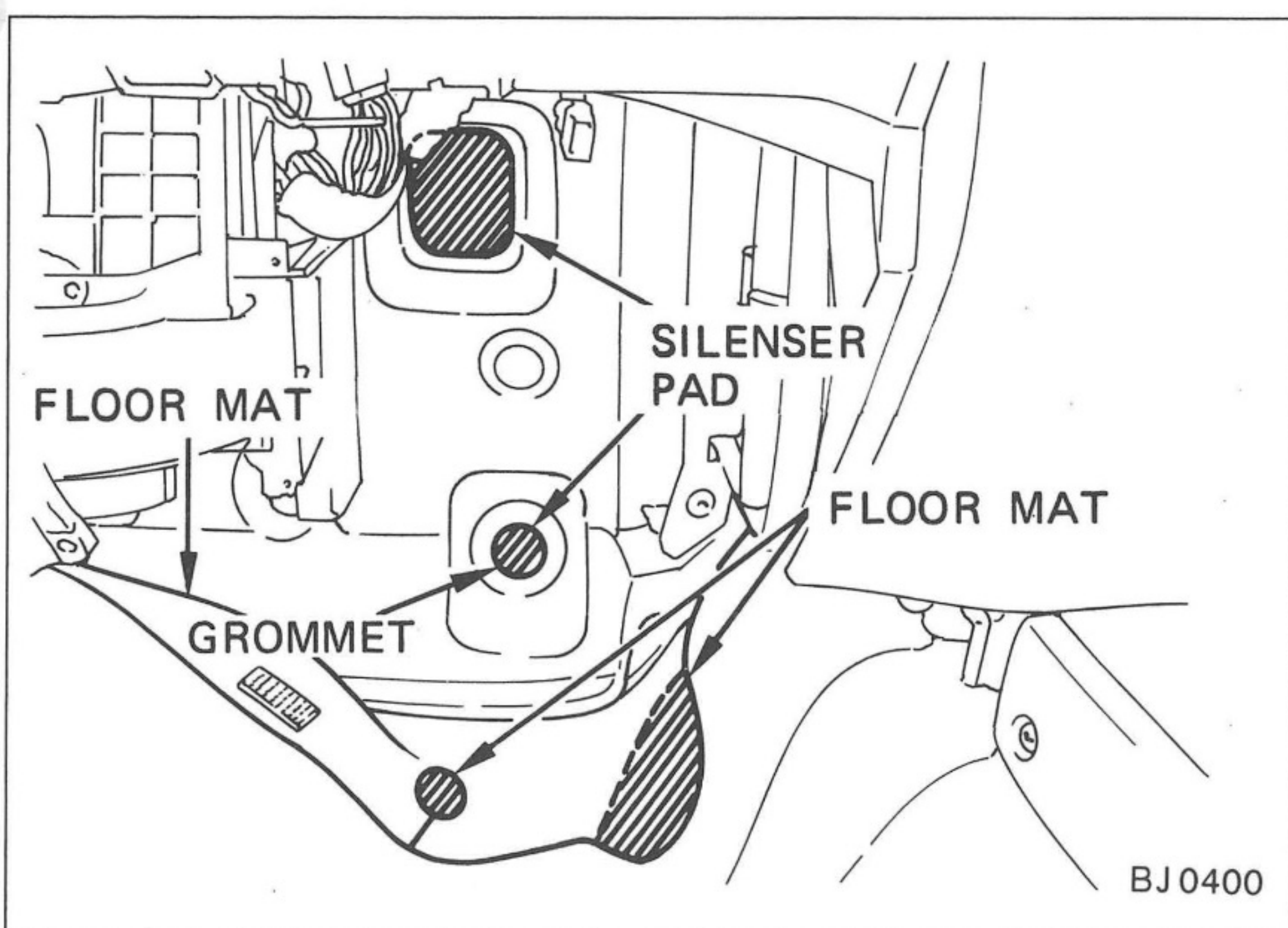

Fig. 5

(h) Temporarily pull the floor mat down and cut out 2 shaded areas from floor mat.

(i) Cut out 2 shaded areas from silencer pad.

(j) Remove and discard the grommet from the fire wall.

(k) Plate cover .....Discard

**NOTE**

*Keep two original bolts.*

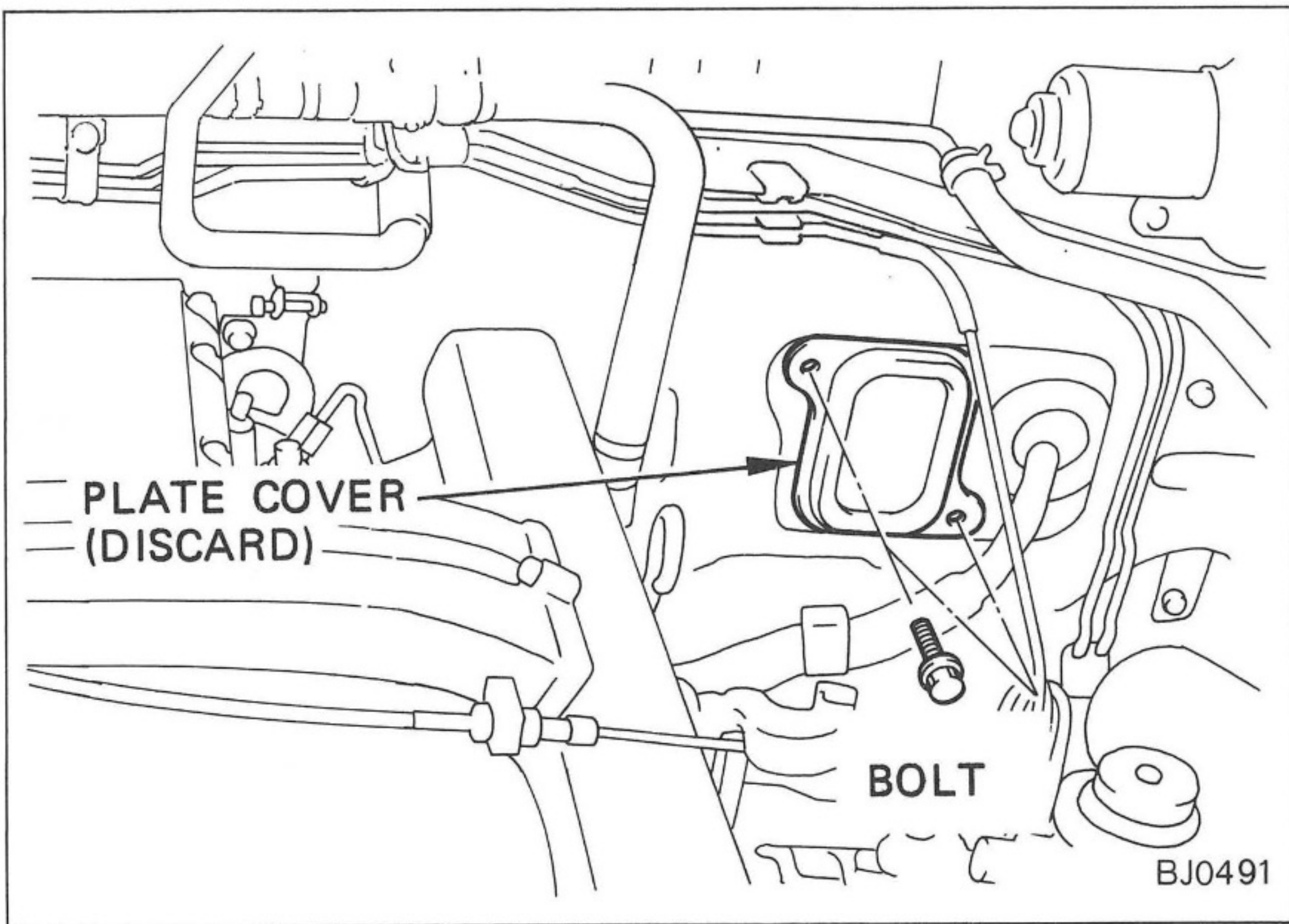

Fig. 6

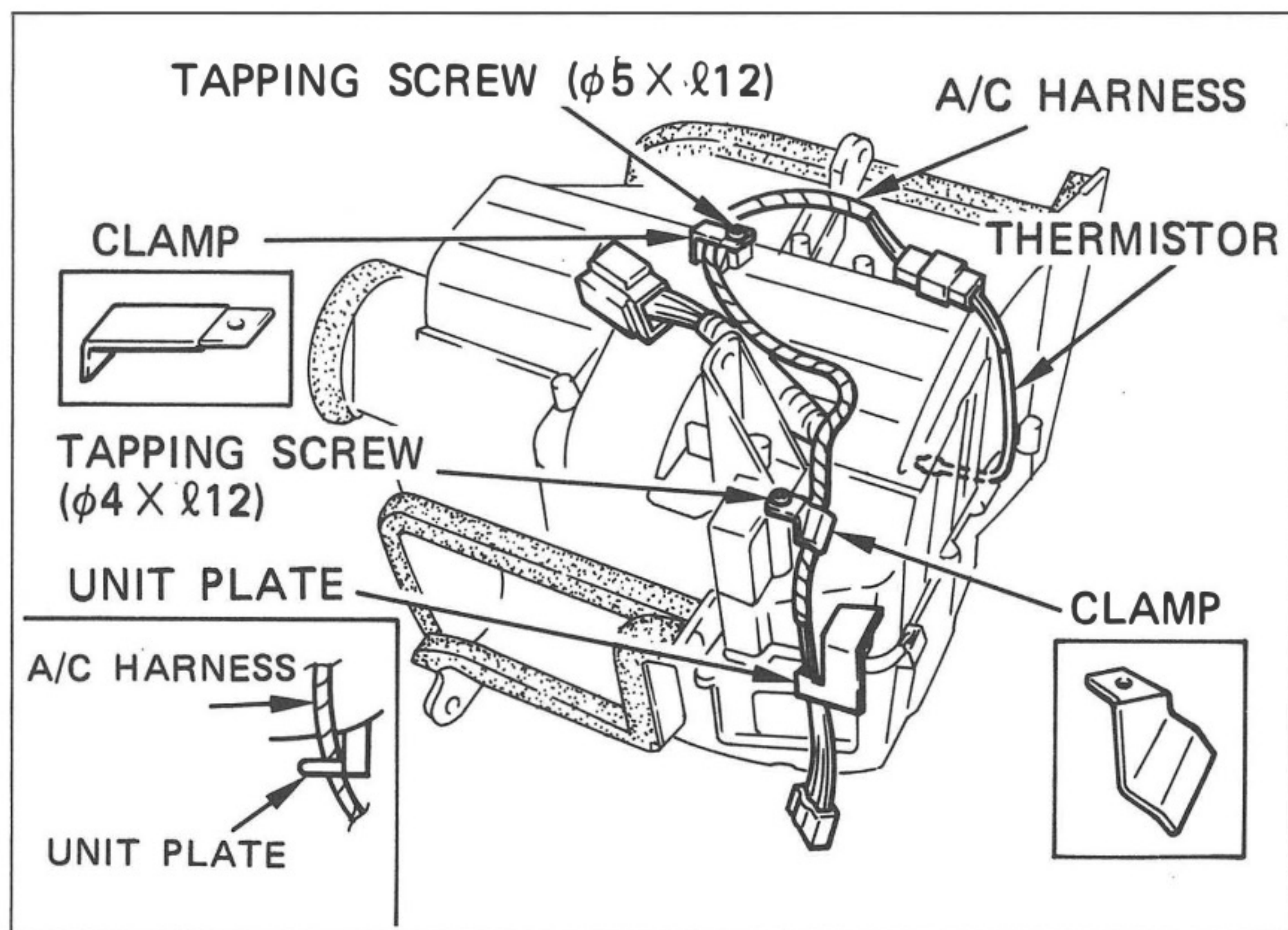

Fig. 7

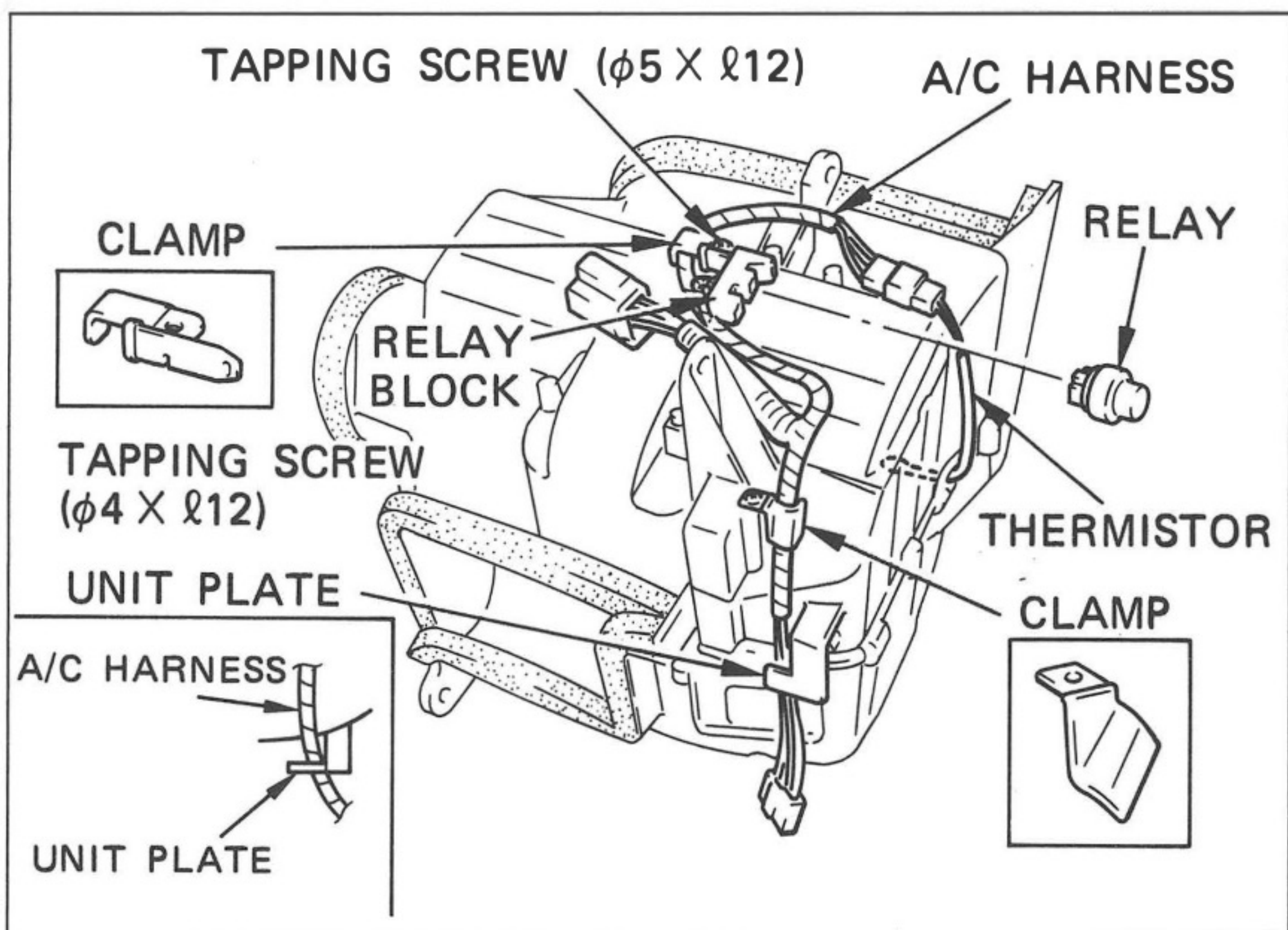

Fig. 8

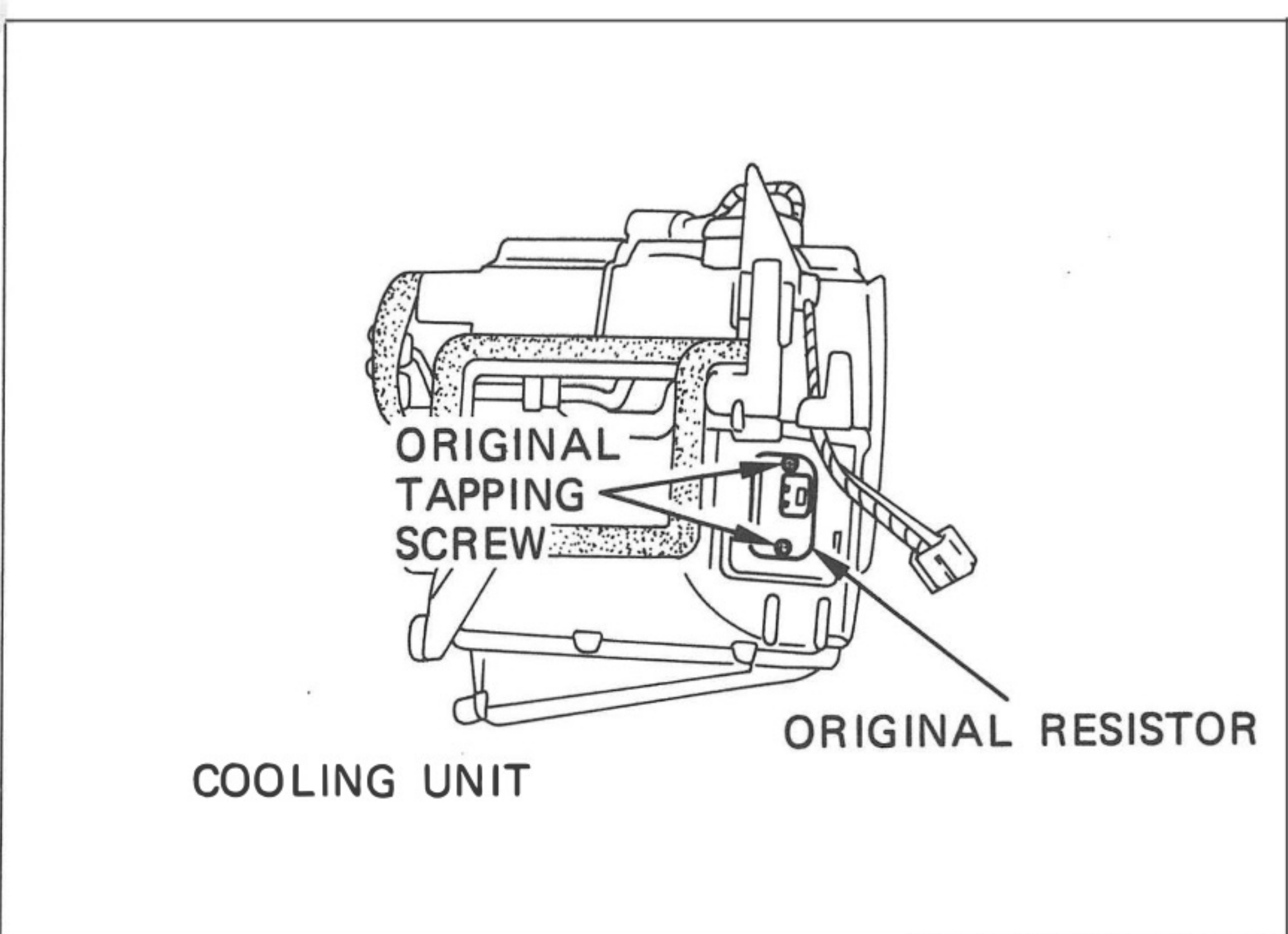

Fig. 9

## (2) COOLING UNIT

### ■ FOR 3F, 3F-E AND 1HD-T ENGINE WITH MANUAL TRANSMISSION ONLY

- (a) Install and secure the A/C harness to the cooling unit using two clamps and two tapping screws.

#### NOTE

Secure the A/C harness using the unit plate as shown.

- (b) Connect the 2-P connector of the A/C harness to the thermistor.

### ■ FOR 1HZ ENGINE AND 1HD-T ENGINE WITH AUTOMATIC TRANSMISSION ONLY

- (c) Install and secure the A/C harness to the cooling unit using two clamps and two tapping screws.

#### NOTE

Secure the A/C harness using the unit plate as shown.

- (d) Connect the 2-P connector of the A/C harness to the thermistor.
- (e) Fasten the relay block to the clamp and install the 4-P relay.

- (f) Install the original blower resistor to the cooling unit using two original tapping screws.

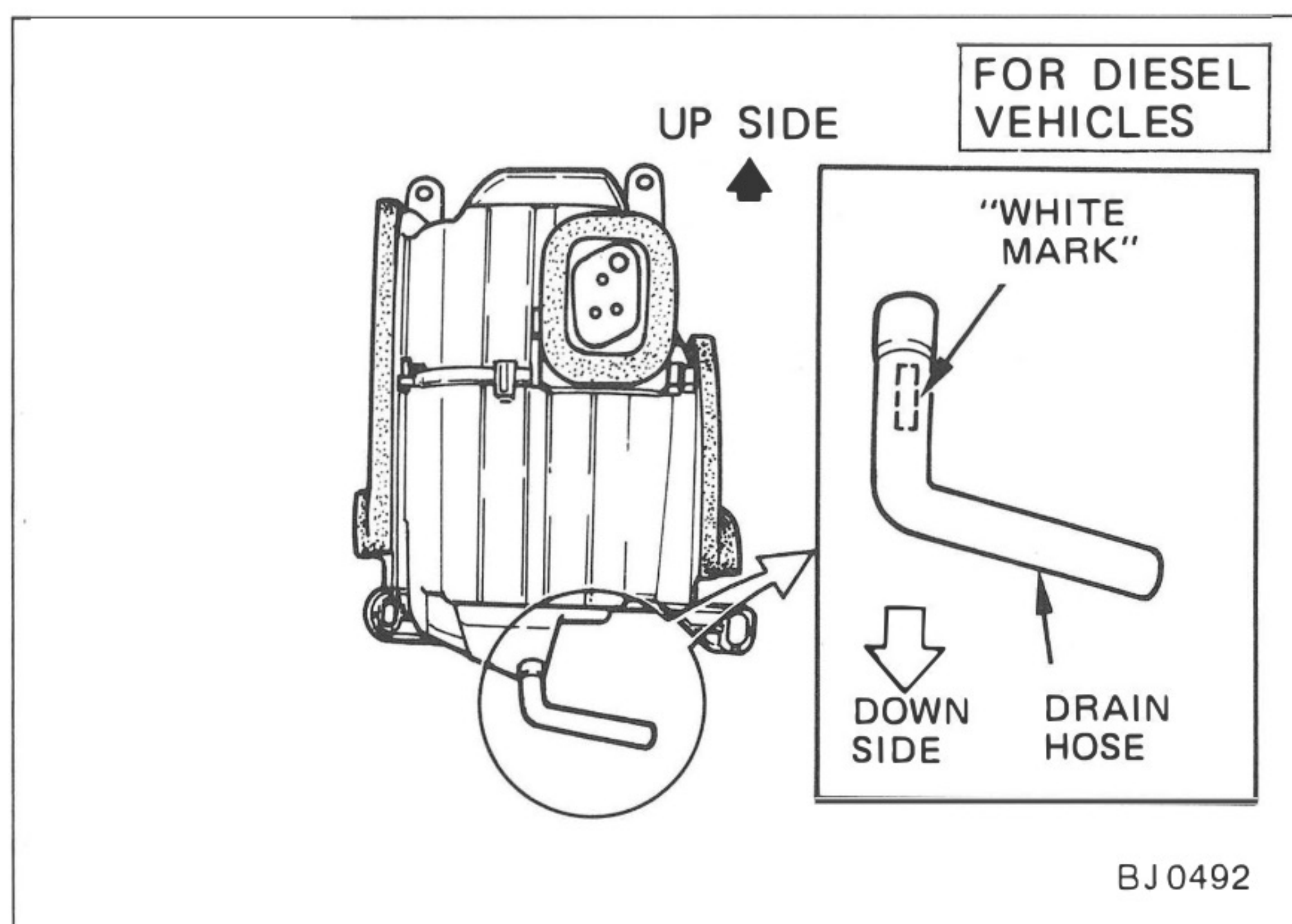

Fig.10

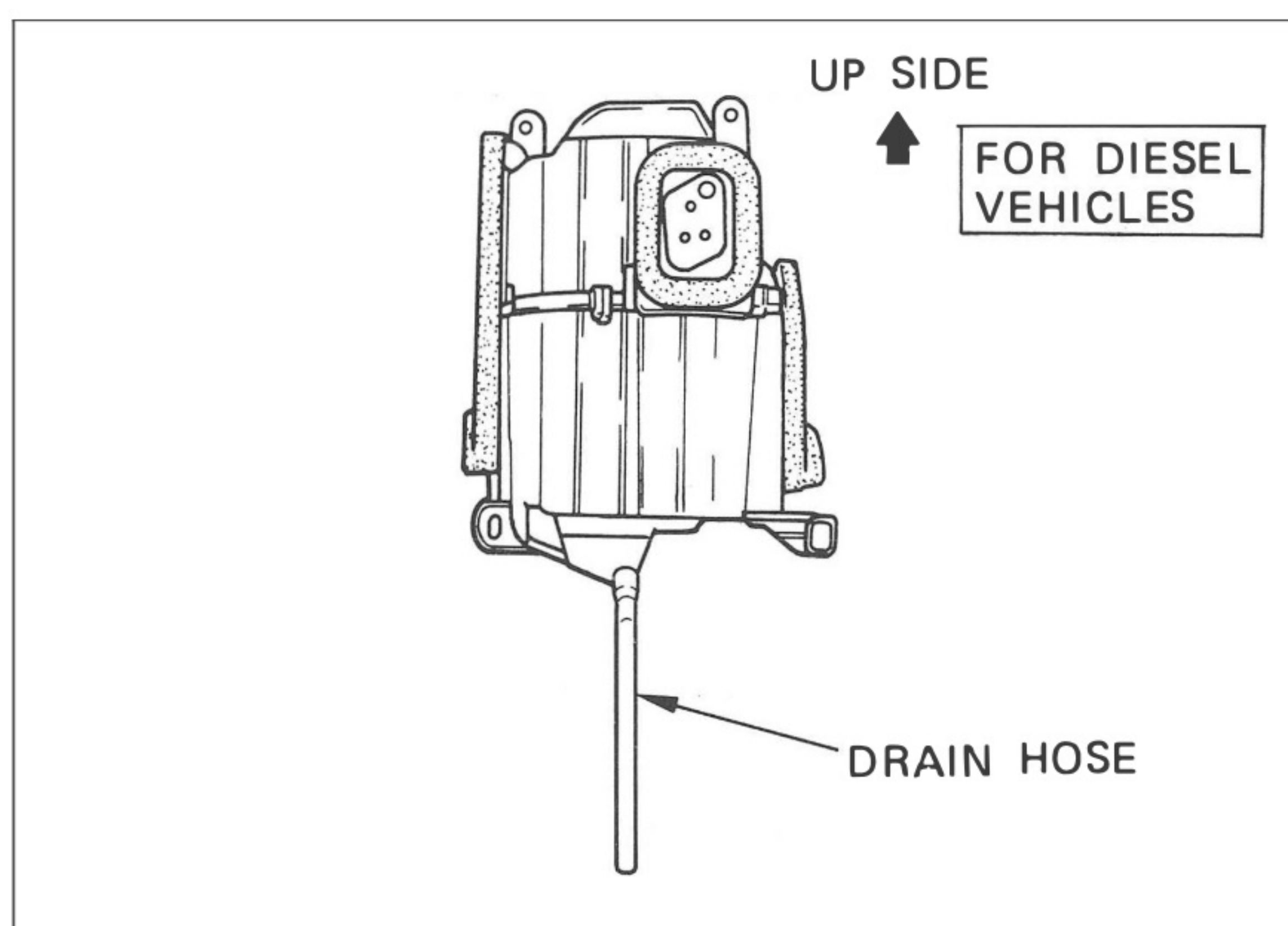

Fig.11

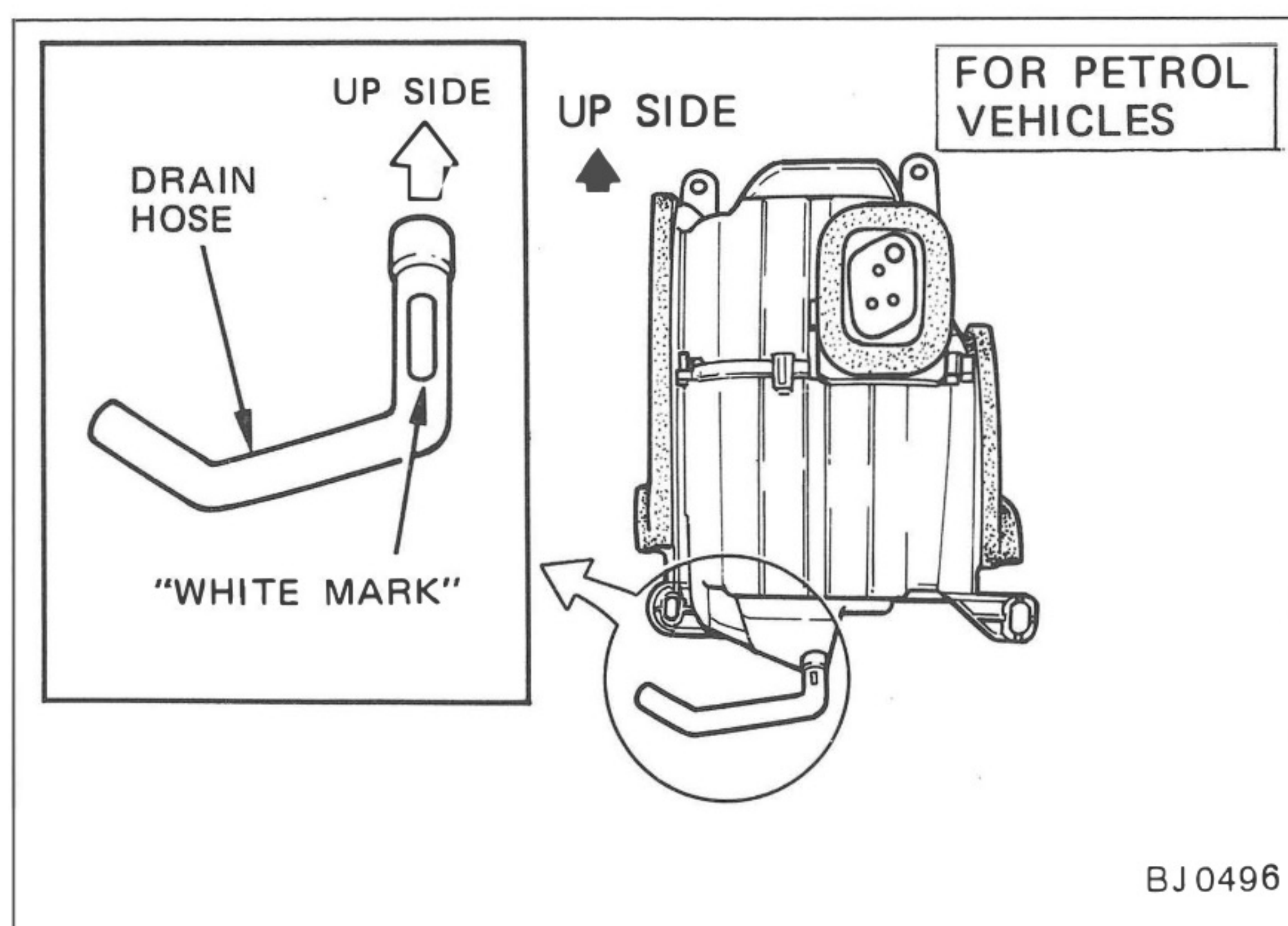

Fig.12

■ FOR DIESEL VEHICLES

- (g) If the shorter drain hose is supplied in the kit, install the drain hose to the cooling unit with the "white mark" downwards.

- (h) If the longer drain hose is supplied in the kit, install the drain hose downwards.

■ FOR PETROL VEHICLES

- (i) Install the drain hose to the cooling unit with the "white mark" upwards.

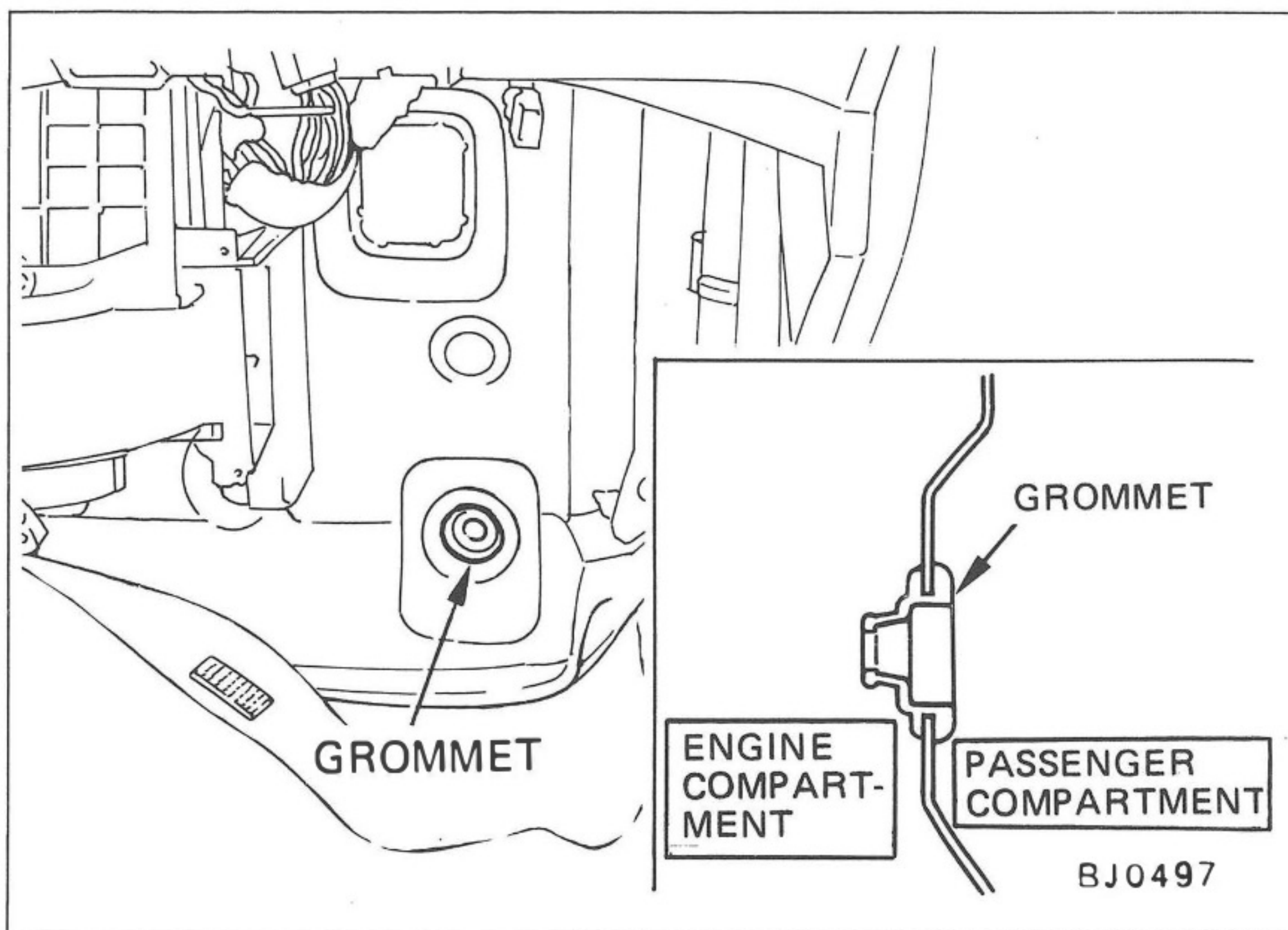

Fig.13

- (i) Install the grommet for the drain hose from passenger compartment.

**NOTE**

*Lift the silencer pad to install the drain hose grommet.*

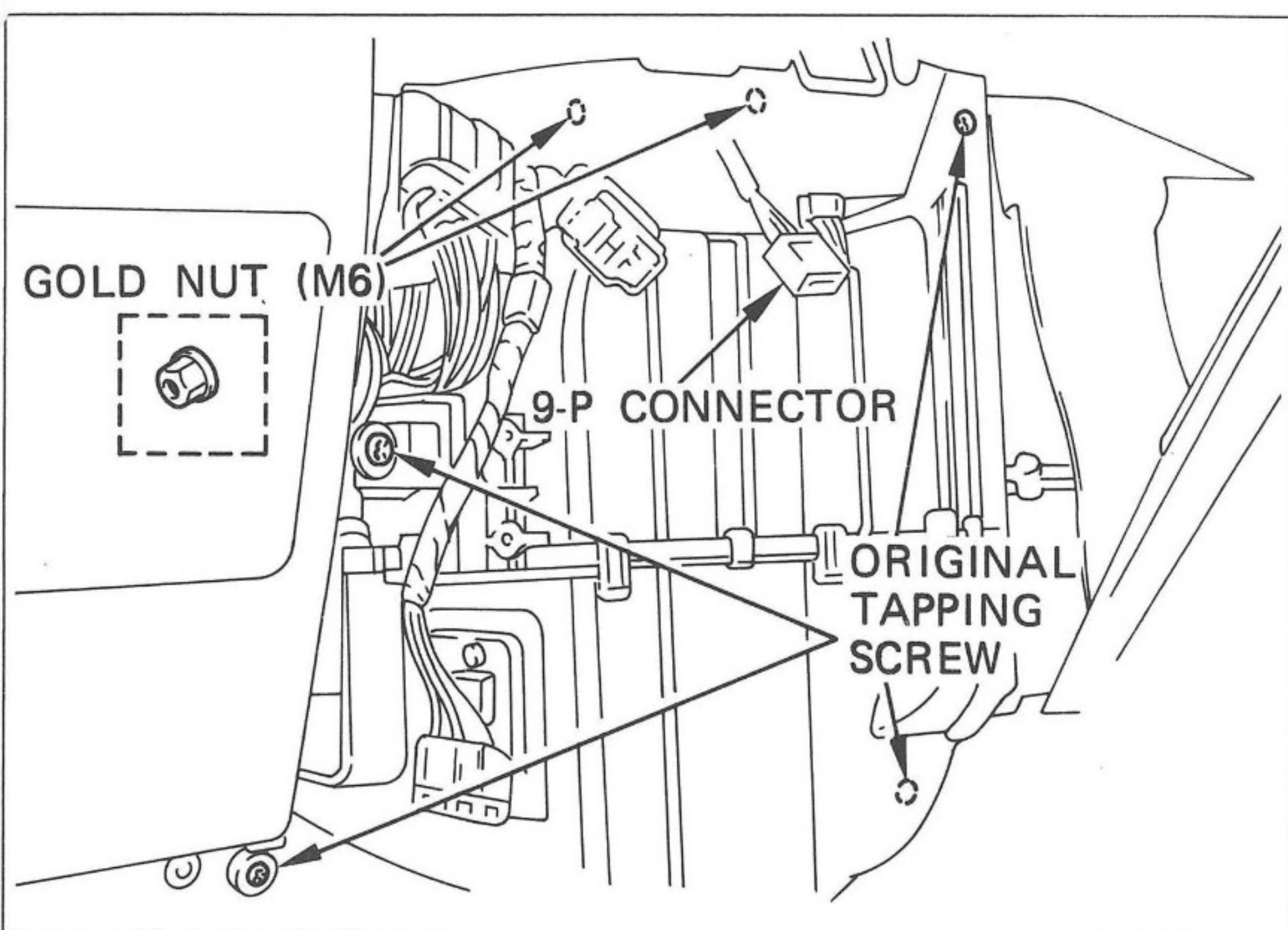

Fig.14

- (k) Untape the 9-P connector from the vehicle harness, prior to installing the cooling unit.

**HINT**

*The 9-P connector is located between the demister duct and the reinforcement tube.*

- (l) Install the cooling unit using two nuts and four original tapping screws.

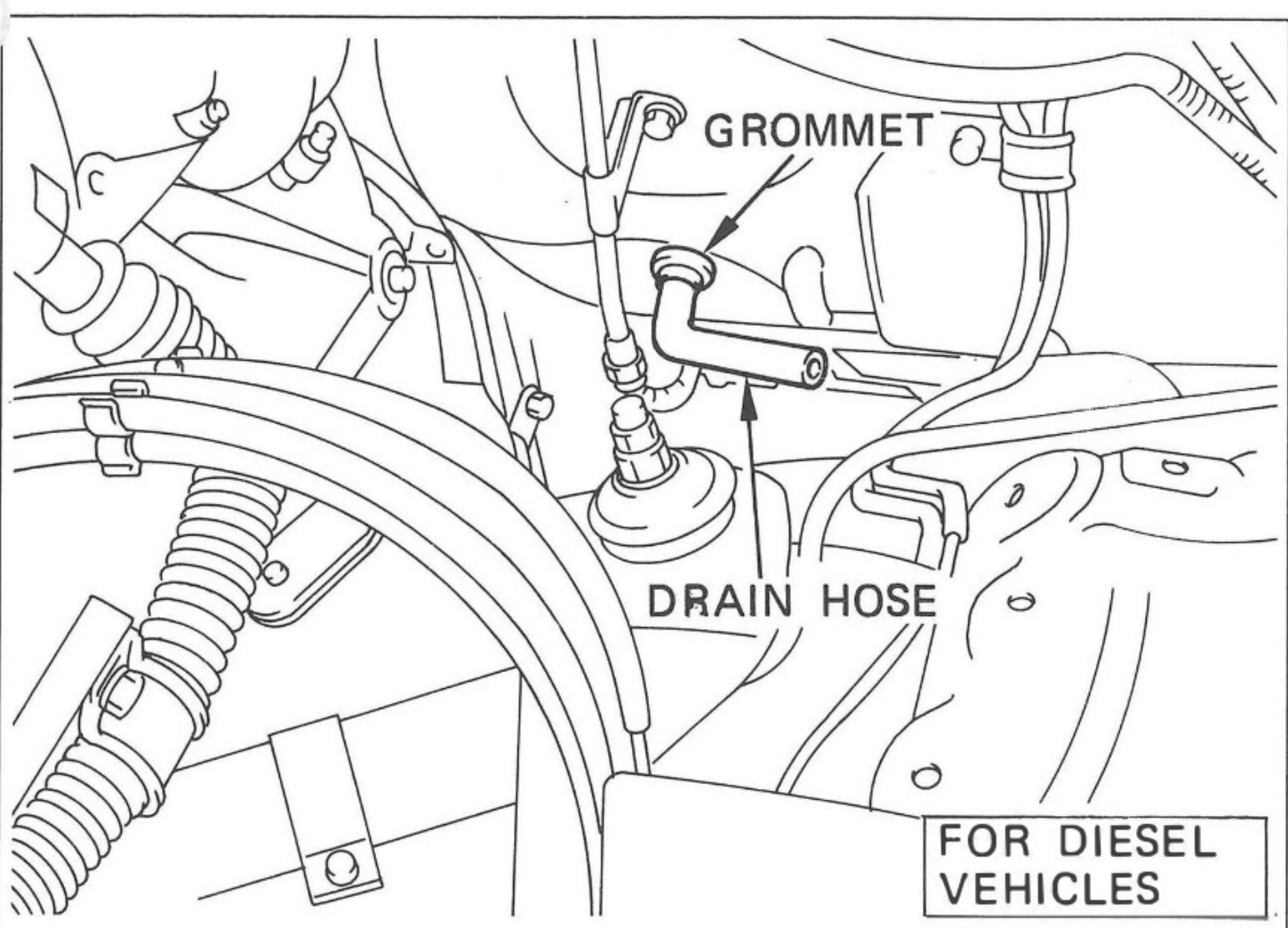

Fig.15

■ FOR DIESEL VEHICLES

- (m) Inspect the drain hose routing as shown, if the shorter drain hose is supplied in the kit.

**NOTE**

*Ensure the drain hose is not kinked.*

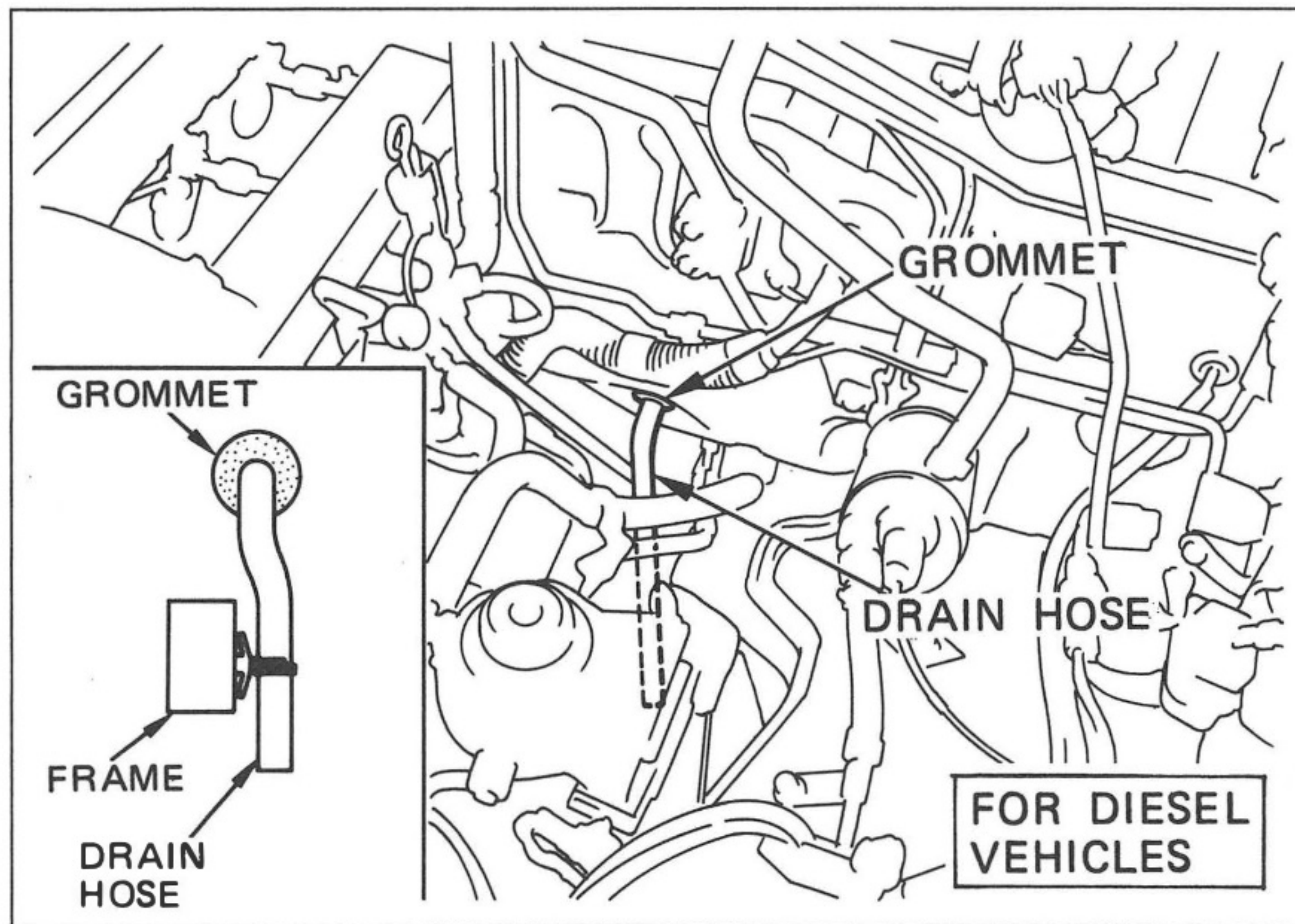

Fig.16

- (n) Route the drain hose as shown, if the longer drain hose is supplied in the kit.

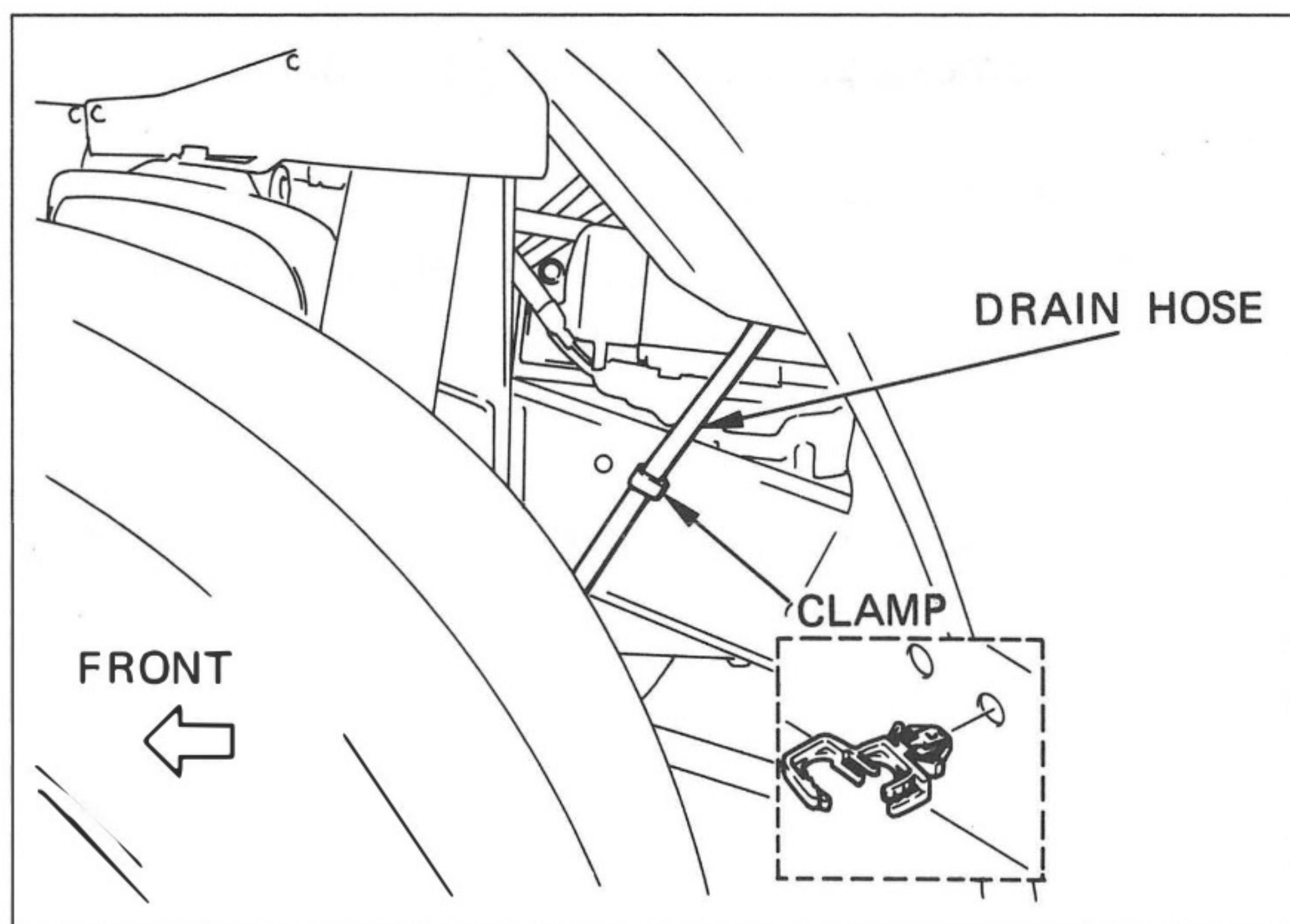

Fig.17

- (o) Fasten the drain hose on the frame using a clamp.

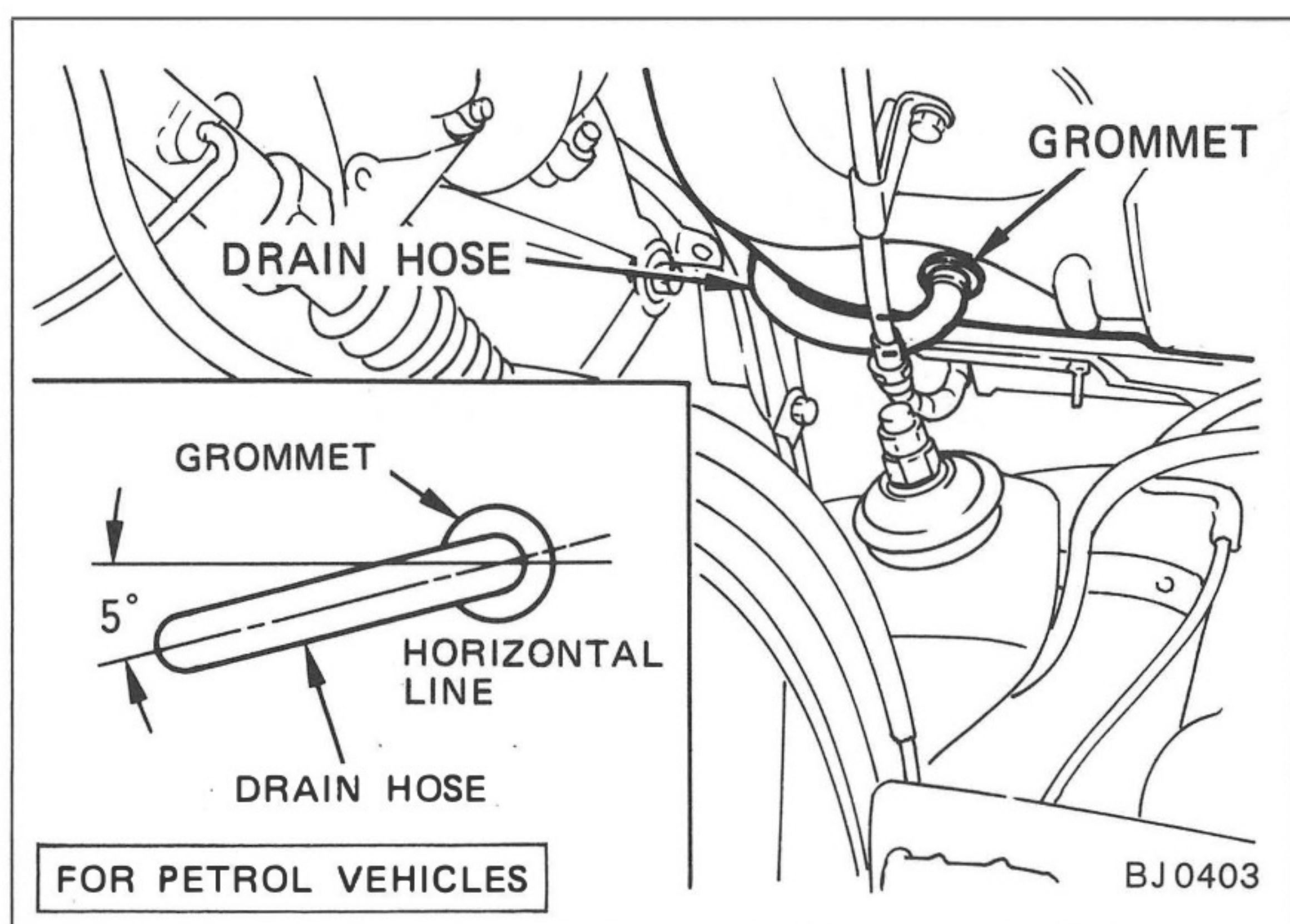

Fig.18

■ FOR PETROL VEHICLES

- (p) Inspect the drain hose routing.

**NOTE**

*Ensure the drain hose is not kinked.*

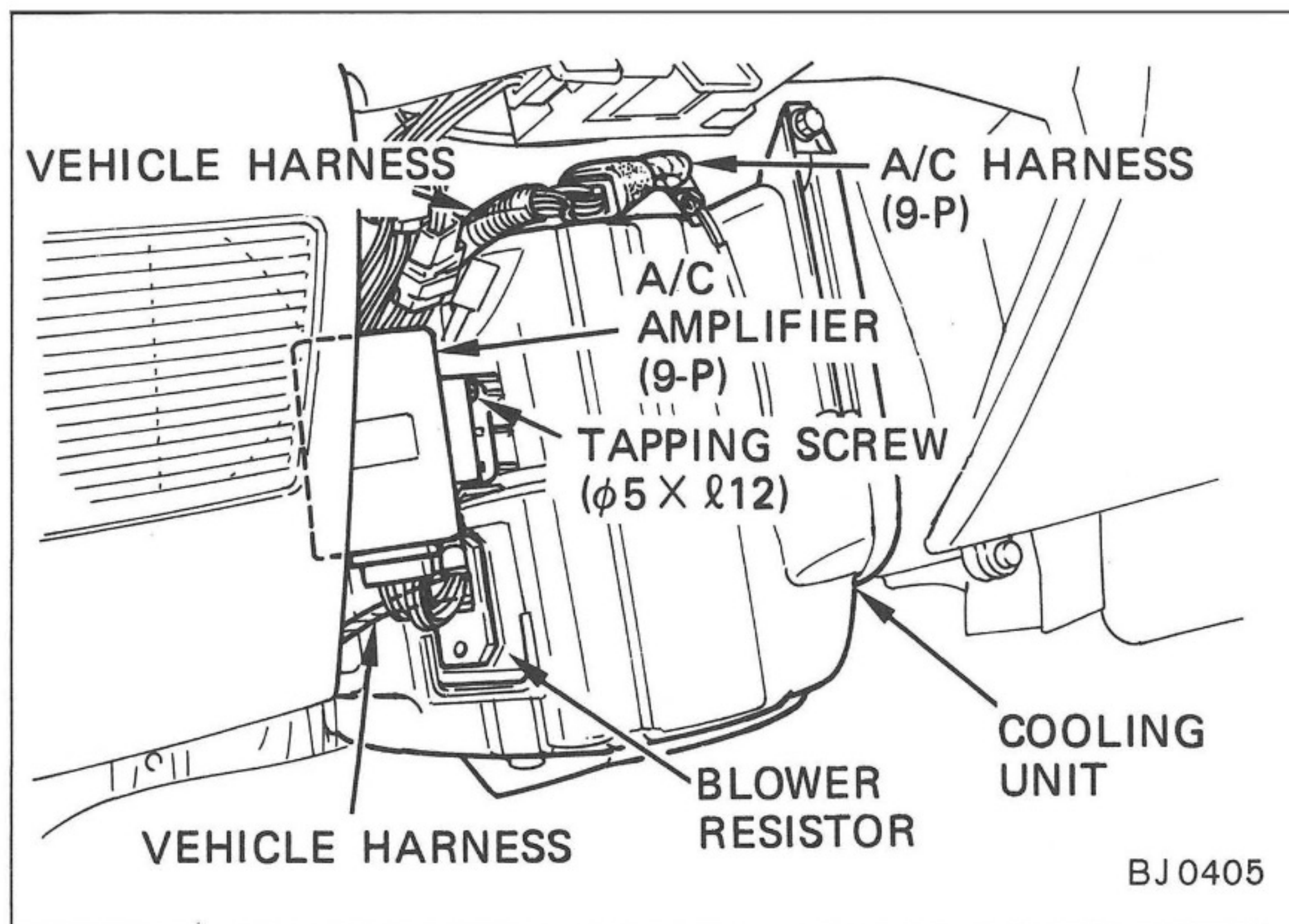

Fig.19

- (q) Install the A/C amplifier to the cooling unit using a tapping screw.
- (r) Reconnect the vehicle harness to the blower resistor.
- (s) Connect 9-P connector of the A/C harness to vehicle harness.
- (t) Connect the A/C harness to the A/C amplifier (9-P).

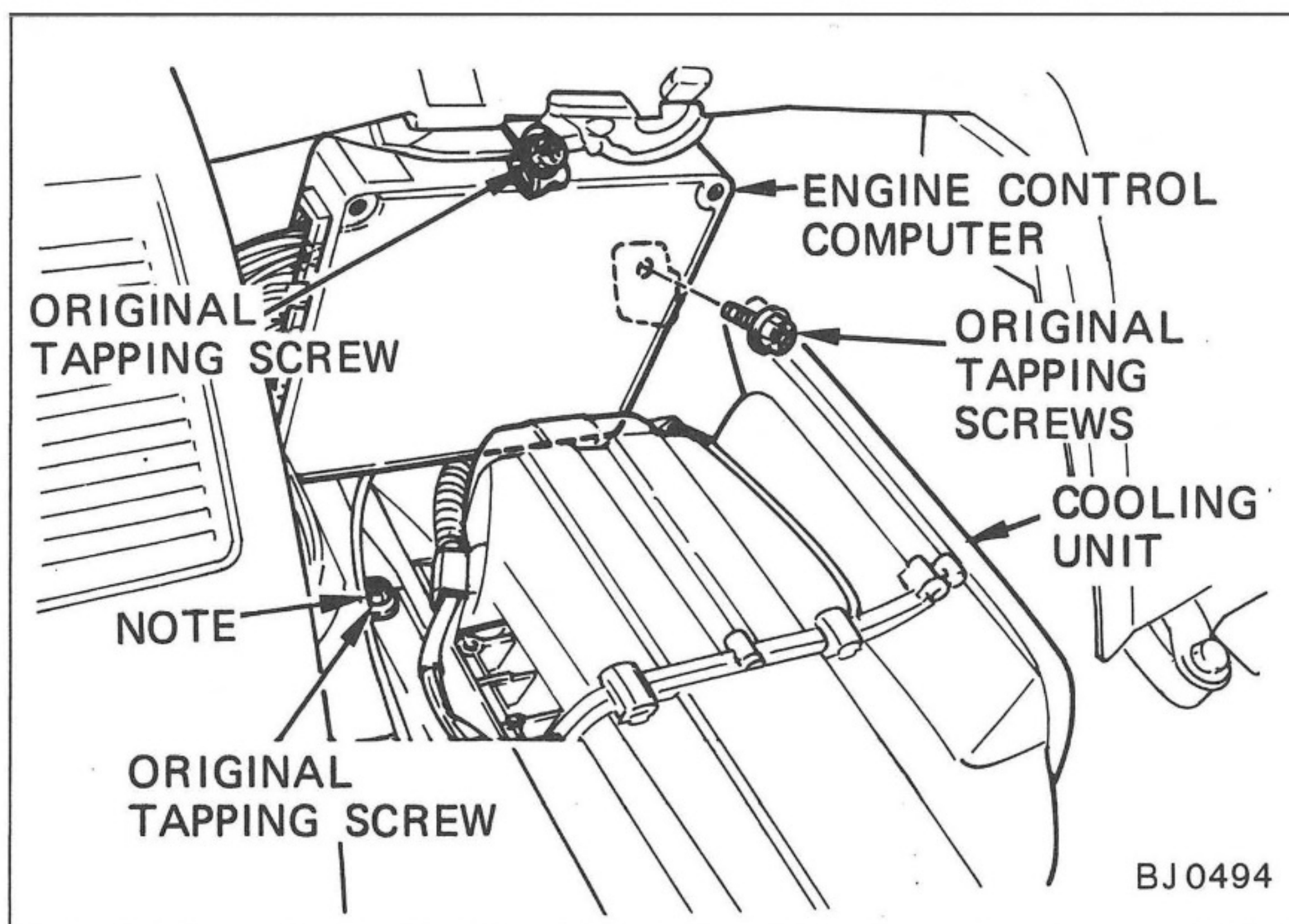

Fig.20

- (u) ■ 3F-E ENGINE MODEL ONLY

Reinstall the engine control computer, using three original tapping screws.

**NOTE**

*The engine control computer is now mounted on the cooling unit as shown.*

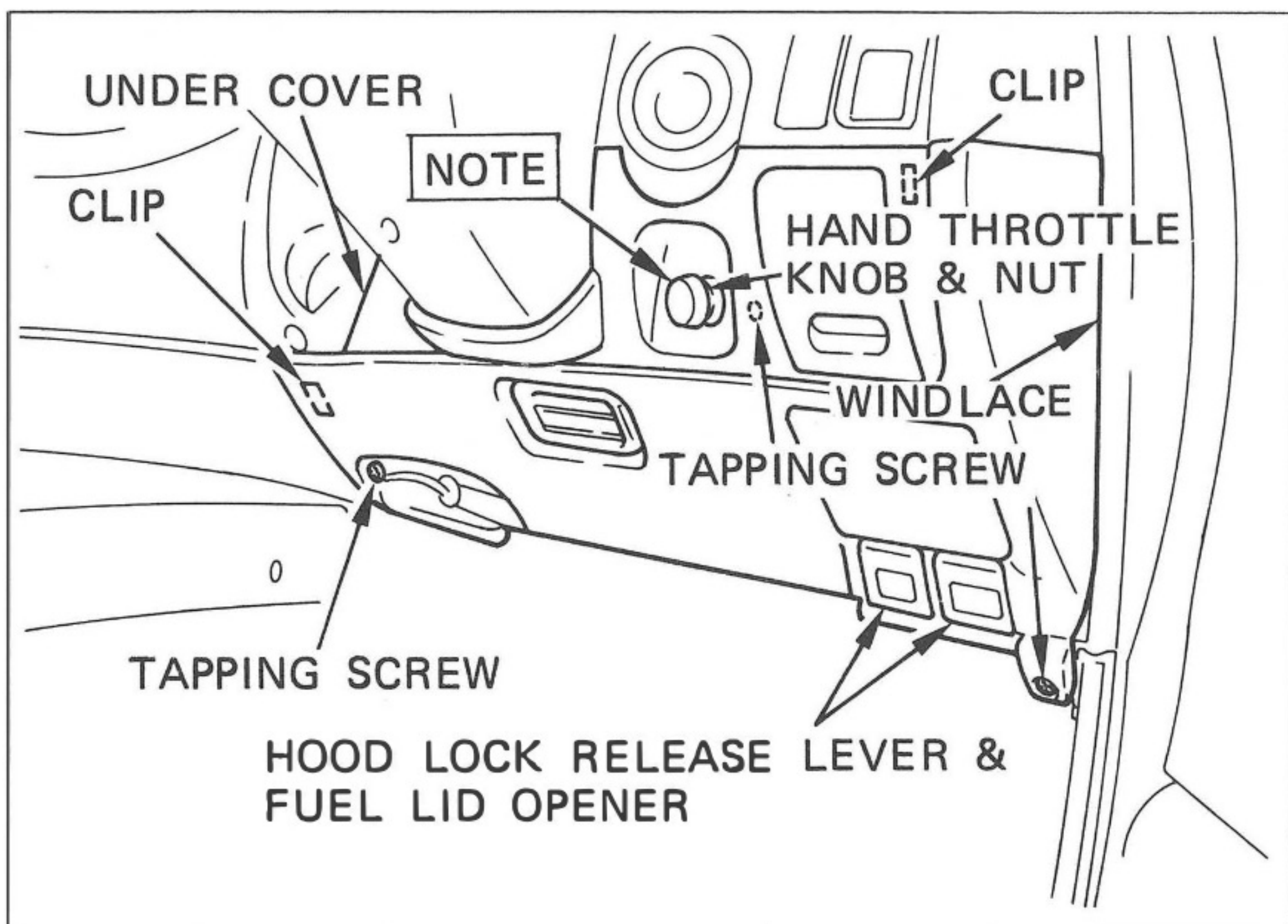

Fig.21

### (3) SIDE AIR DUCT

- (a) Temporarily remove the hand throttle knob and nut.

**NOTE**

To remove the hand throttle knob, depress the lock pin in the knob and pull.

- (b) Temporarily remove the windlace and the under cover with the hood lock release lever & fuel lid opener.

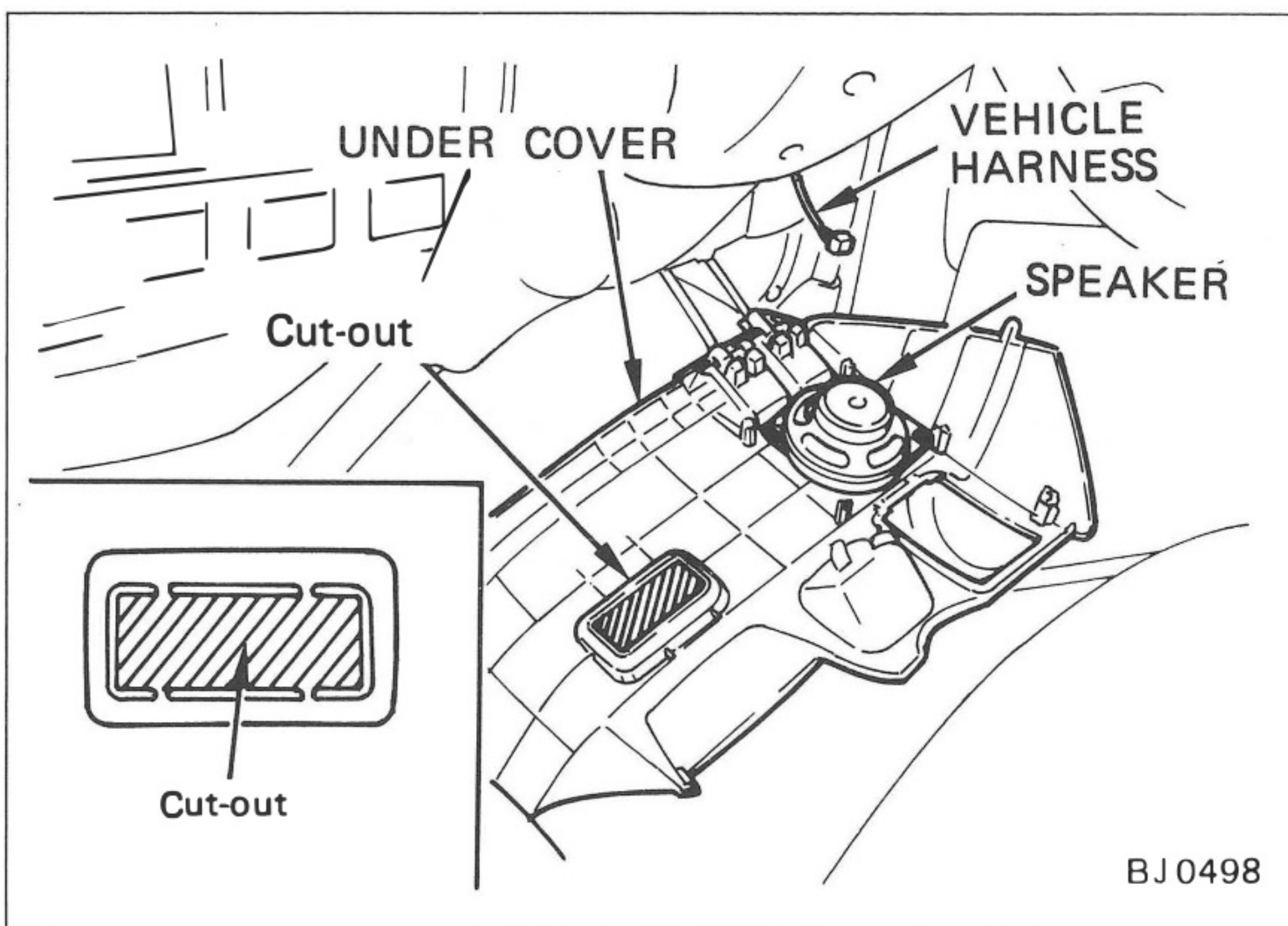

Fig.22

- (c) Disconnect the vehicle harness from the speaker.
- (d) Cut out the shaded area from the under cover.

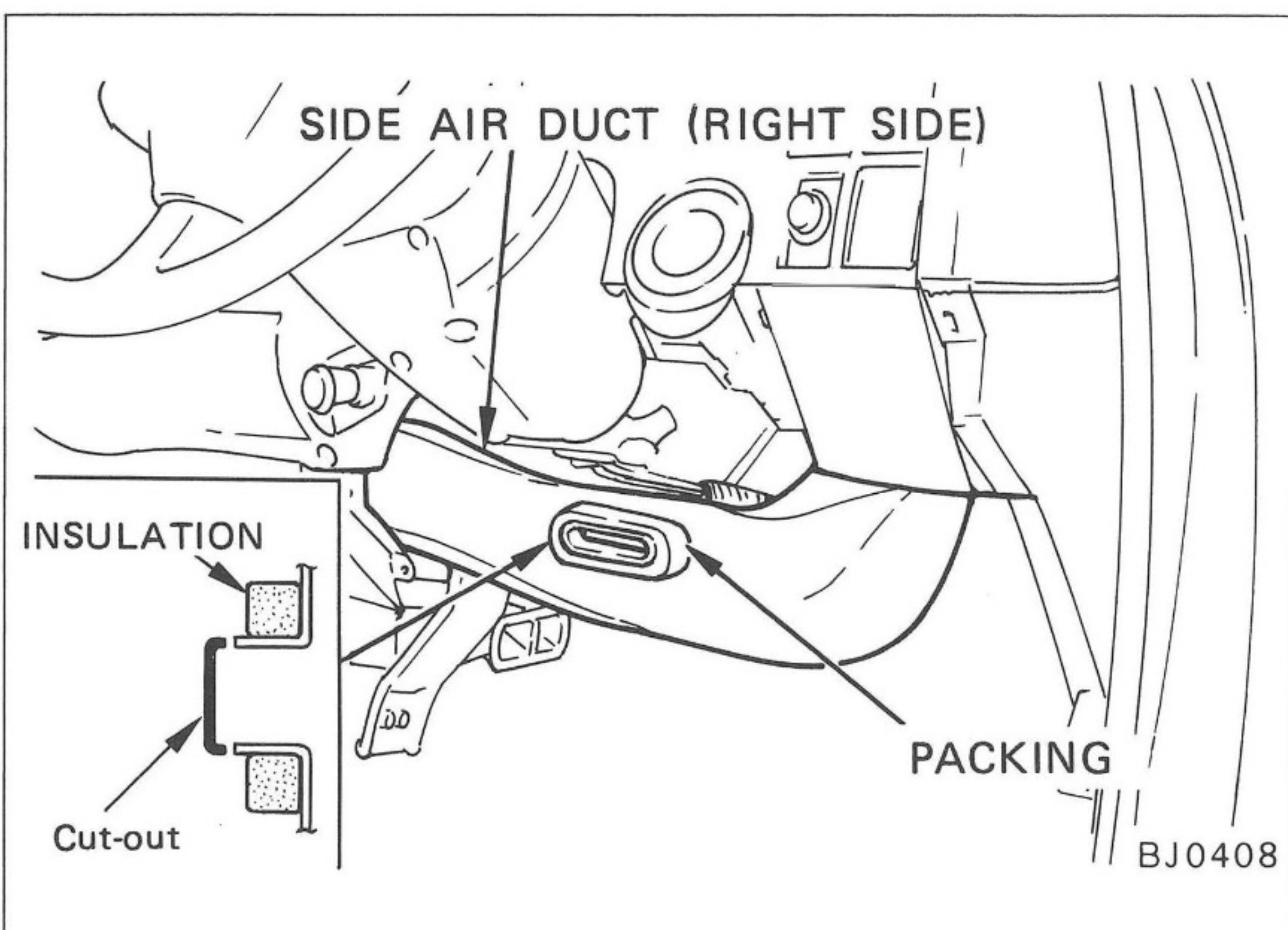

Fig.23

- (e) Cut out the indicated part in figure from side air duct.
- (f) Attach the packing around the air outlet port of side air duct as shown.

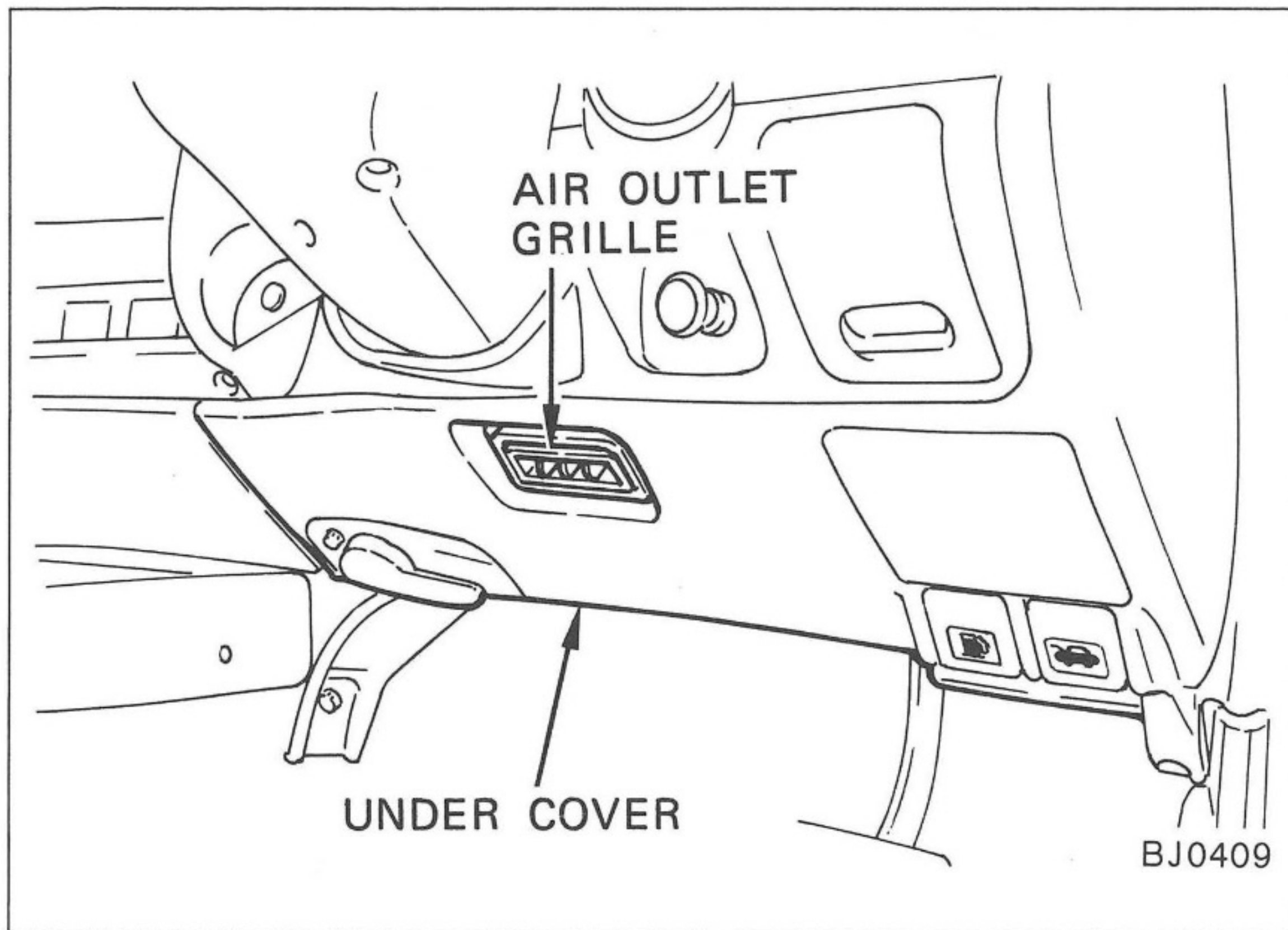

Fig.24

- (g) Reconnect the vehicle harness to speaker.
- (h) Reinstall the under cover.
- (i) Install the air outlet grille into the under cover.

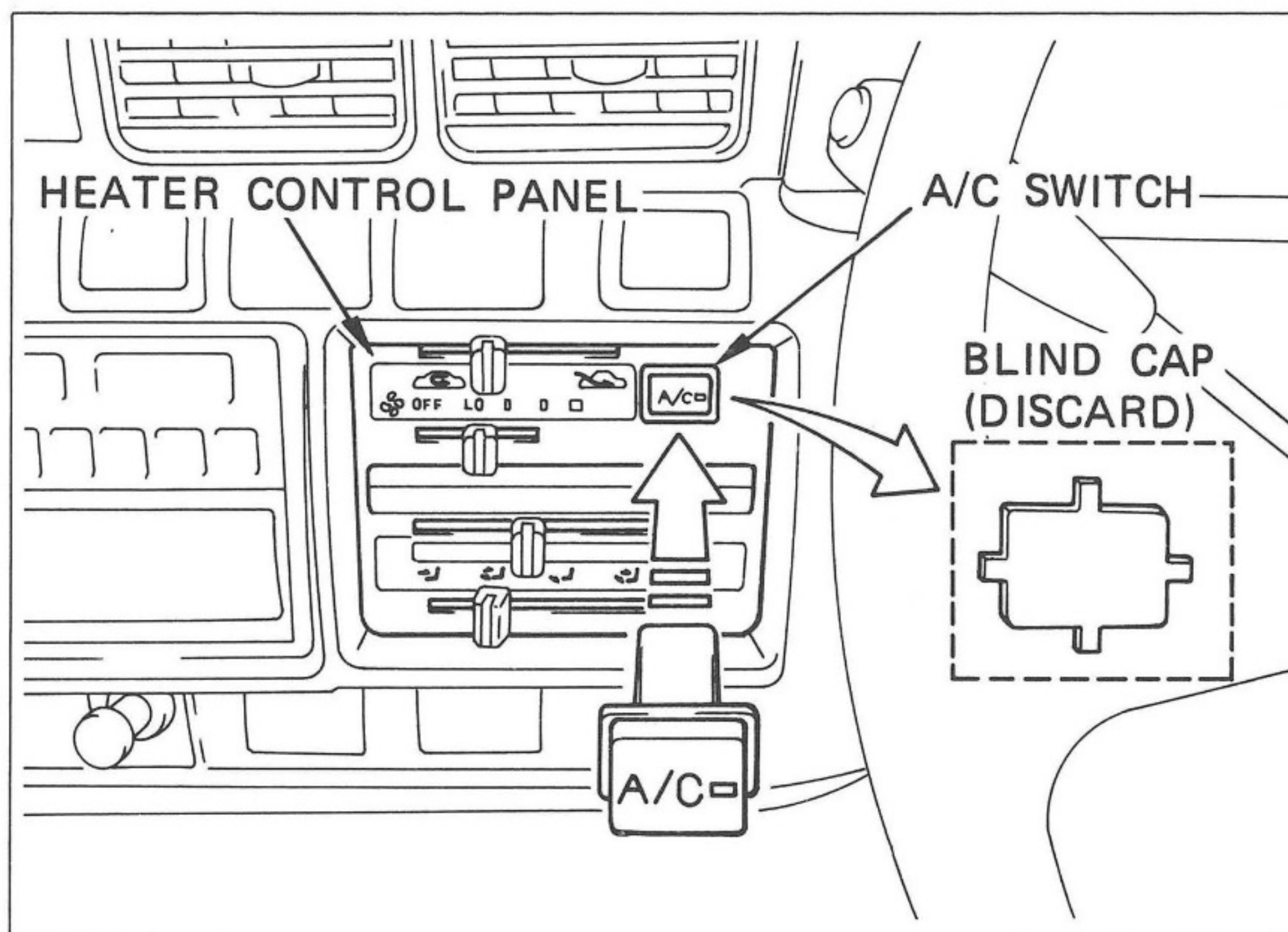

Fig.25

#### (4) A/C SWITCH

- (a) Cut out the blind cap from heater control panel.
- (b) Install the A/C switch.

## 1.2 INSTALLATION : ENGINE COMPARTMENT

### ■ 1HZ, 1HD-T ENGINE MODEL

\* Before making any hoses and tubes connections, apply a few drops of refrigerant oil to the seal of O-ring and coupling nuts.

\* When tightening and loosening fittings, use two wrenches for support.

#### Standard Torque for O-ring Fittings

Size of Tube (inch)	Fitting Torque kg-cm < N-m > (ft-lbs)
0.31	140 < 13.7 > (10.1)
0.50	230 < 22.5 > (16.6)
0.62	330 < 32.3 > (23.8)

Bolted type fittings	Fitting Torque kg-cm < N-m > (ft-lbs)
Compressor Side	250 < 24 > ( 18 )
Condenser side	185 < 18 > ( 13 )
Receiver side	55 < 5.4 > ( 4.0)
Cooling unit side	55 < 5.4 > ( 4.0)
Suction tube side	130 < 13 > ( 9 )

■ PIPING LAYOUT

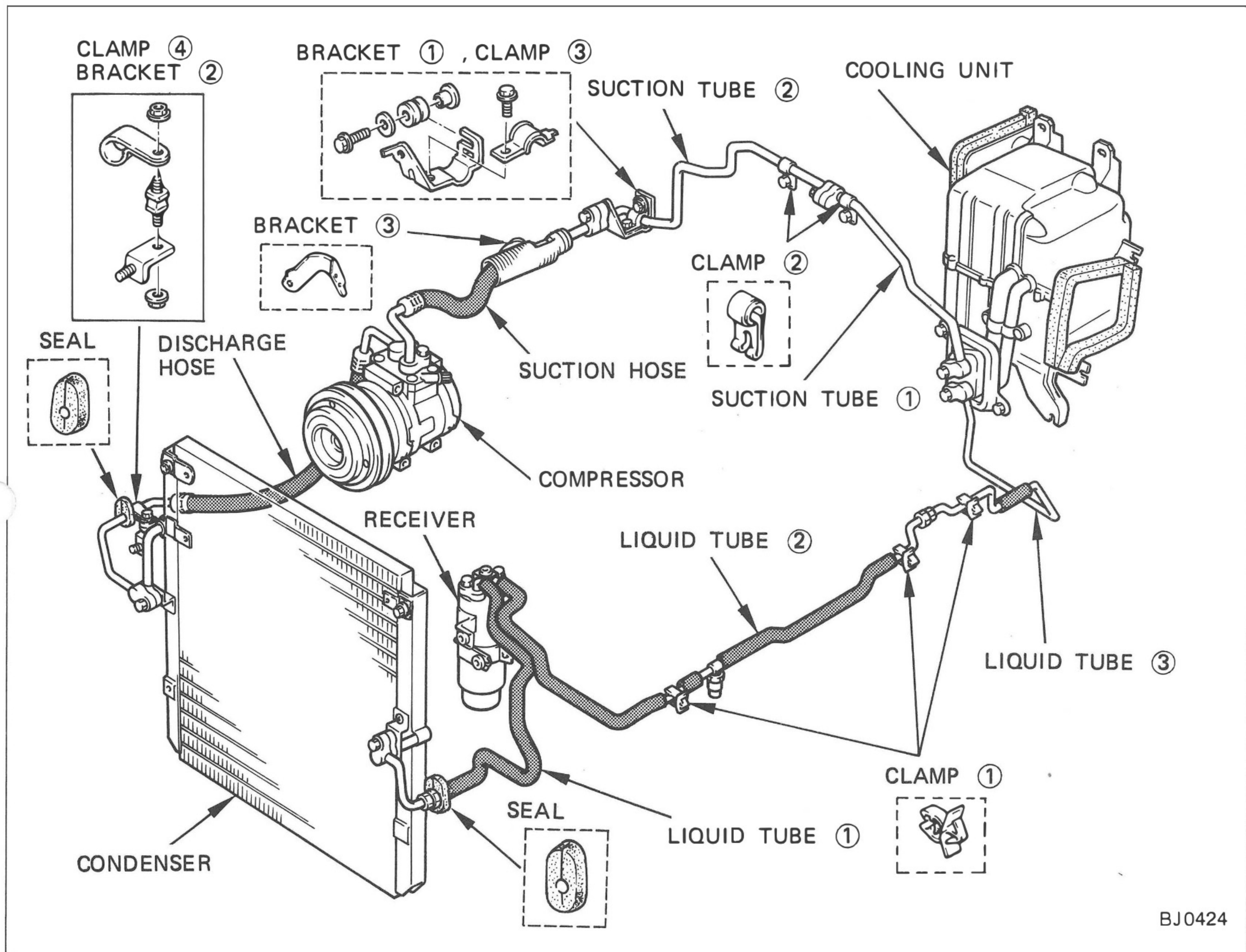

Fig.26

(1) REMOVAL OF PARTS

Remove the following parts

- (a) Radiator reserve tank
- (b) Battery

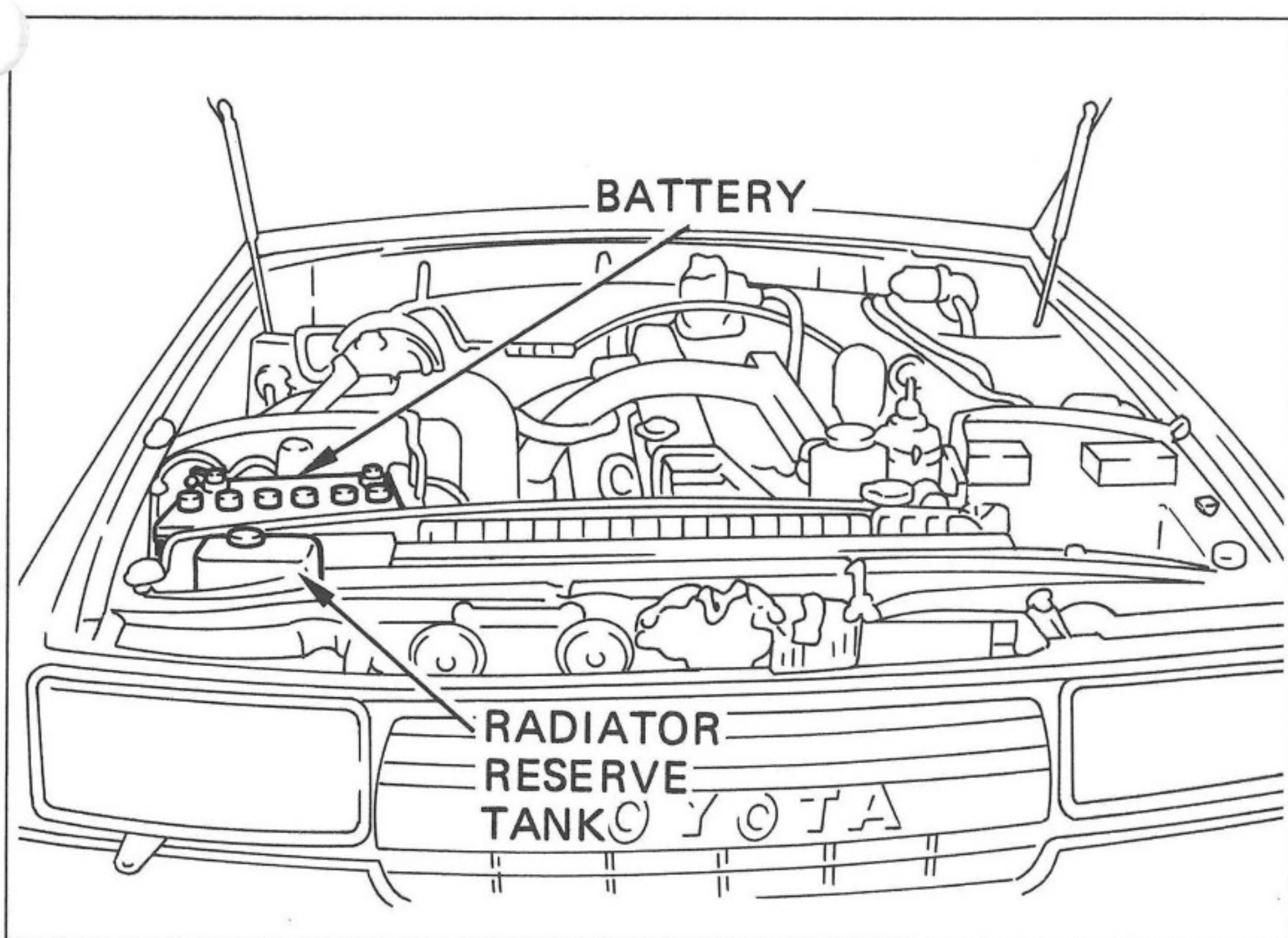

Fig.27

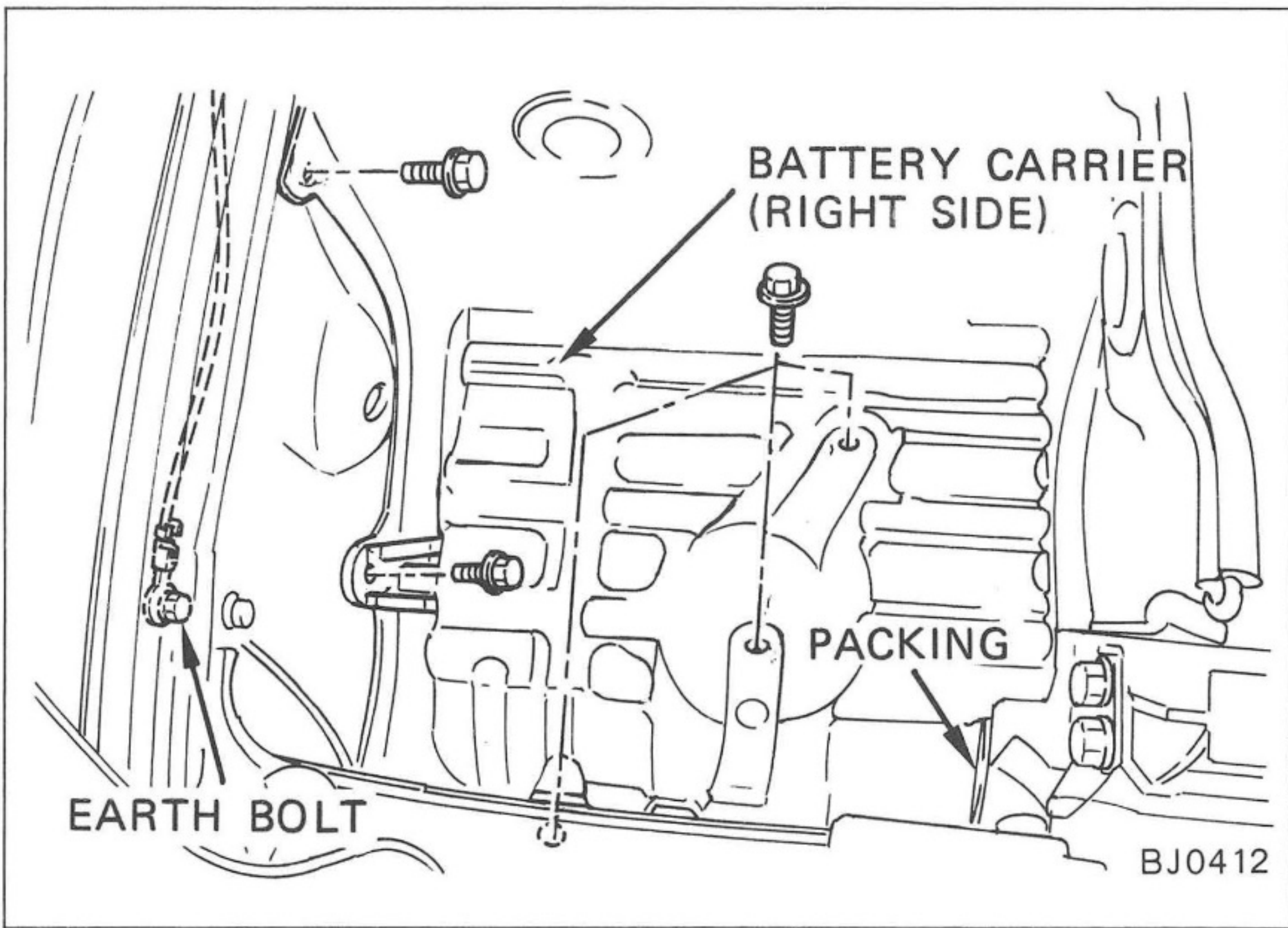

Fig.28

(c) Earth bolt, Battery carrier and Packing.

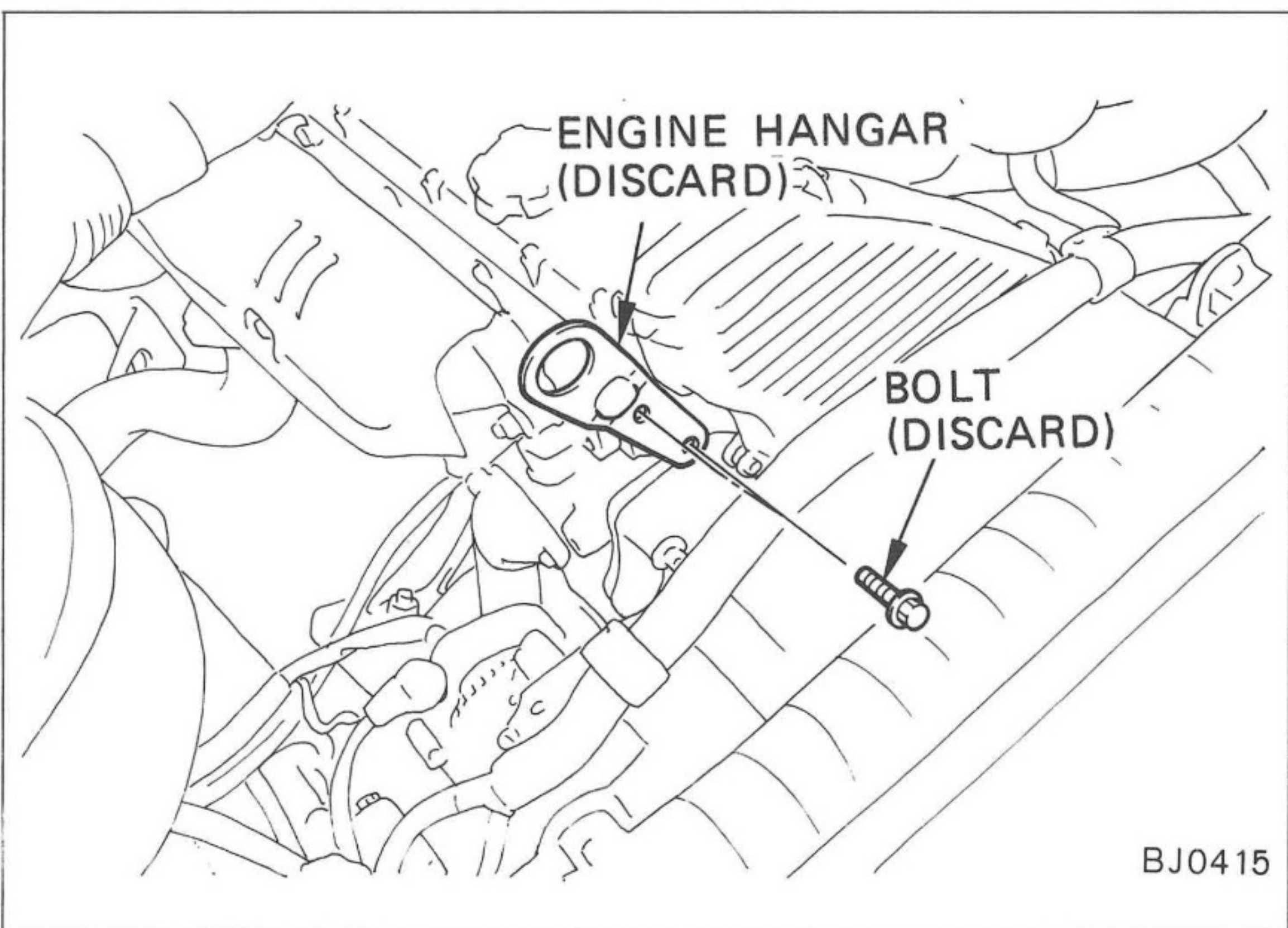

Fig.29

(d) Engine hanger & bolt .....Discard

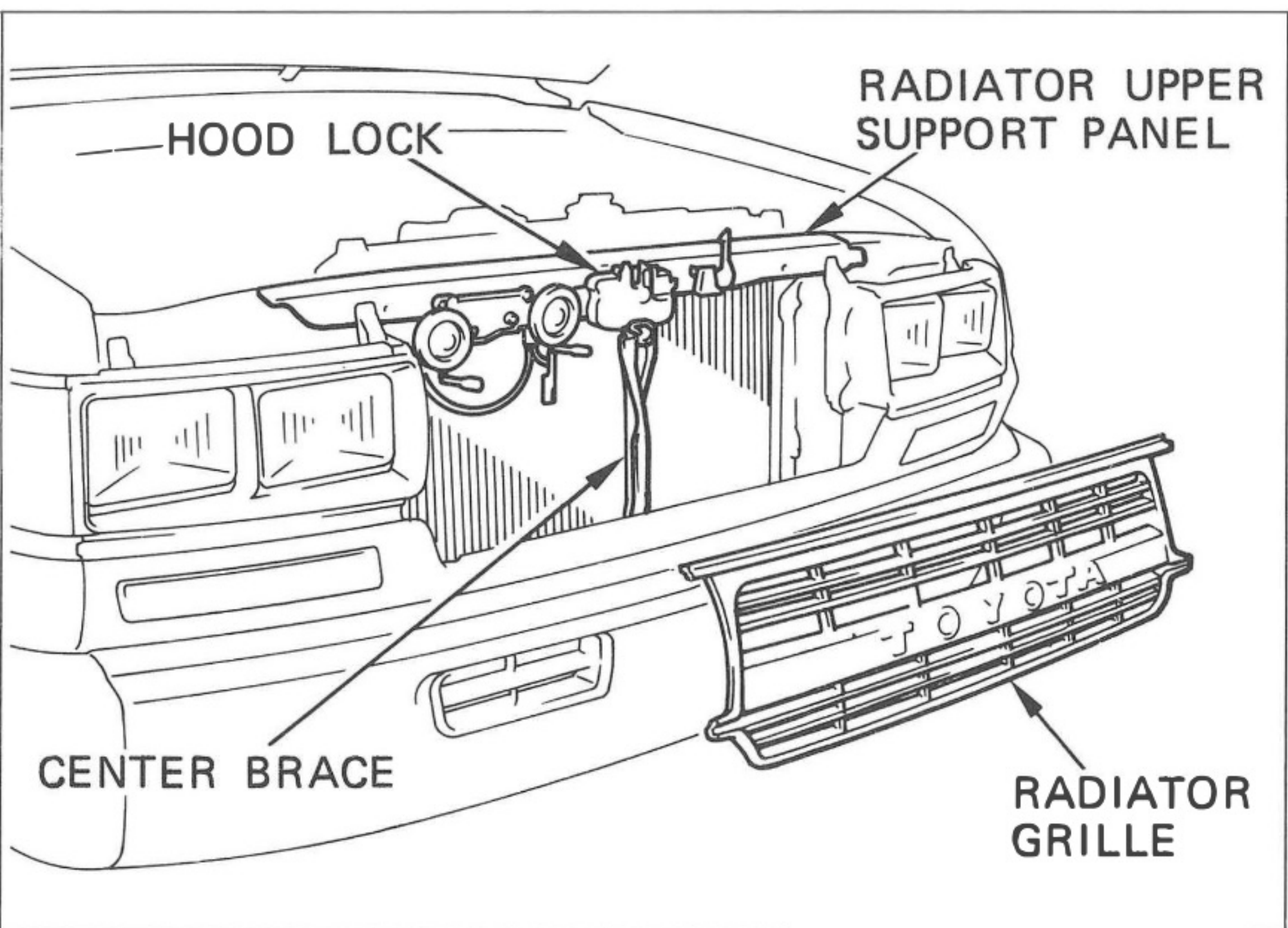

Fig.30

- (e) Radiator grille
- (f) Hood lock and centre brace.
- (g) Radiator upper support panel.

**NOTE**

- 1) Disconnect the horn harness.
- 2) Unclip the vehicle harness from the radiator upper support panel.

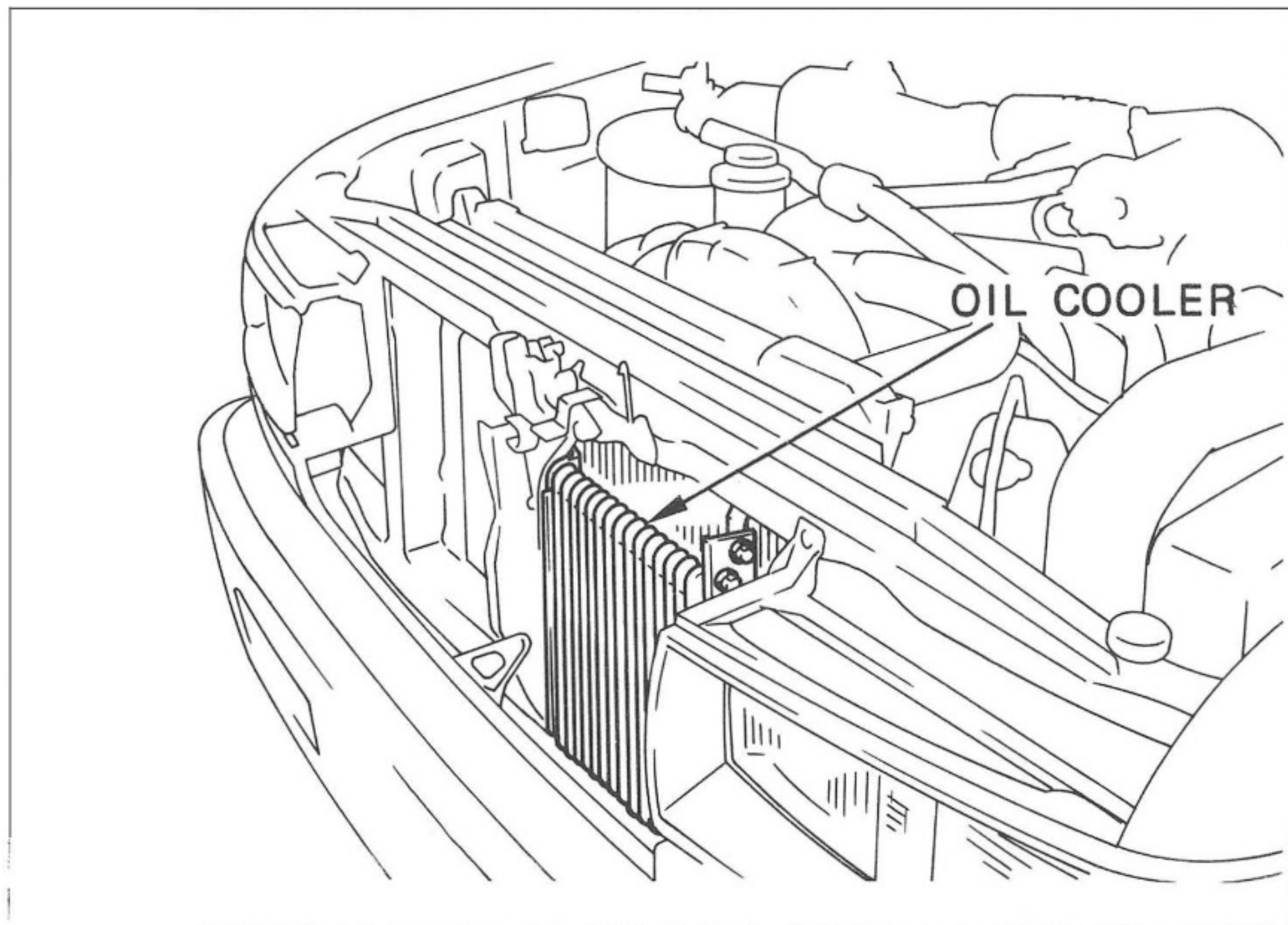

Fig.31

(h) Oil cooler (Equipped model only)

**CAUTION**

*Don't disconnect the oil cooler hose.*

**NOTE**

*Remove only the mounting bolts for the oil cooler, which are located two on the centre brace and one on the radiator support panel.*

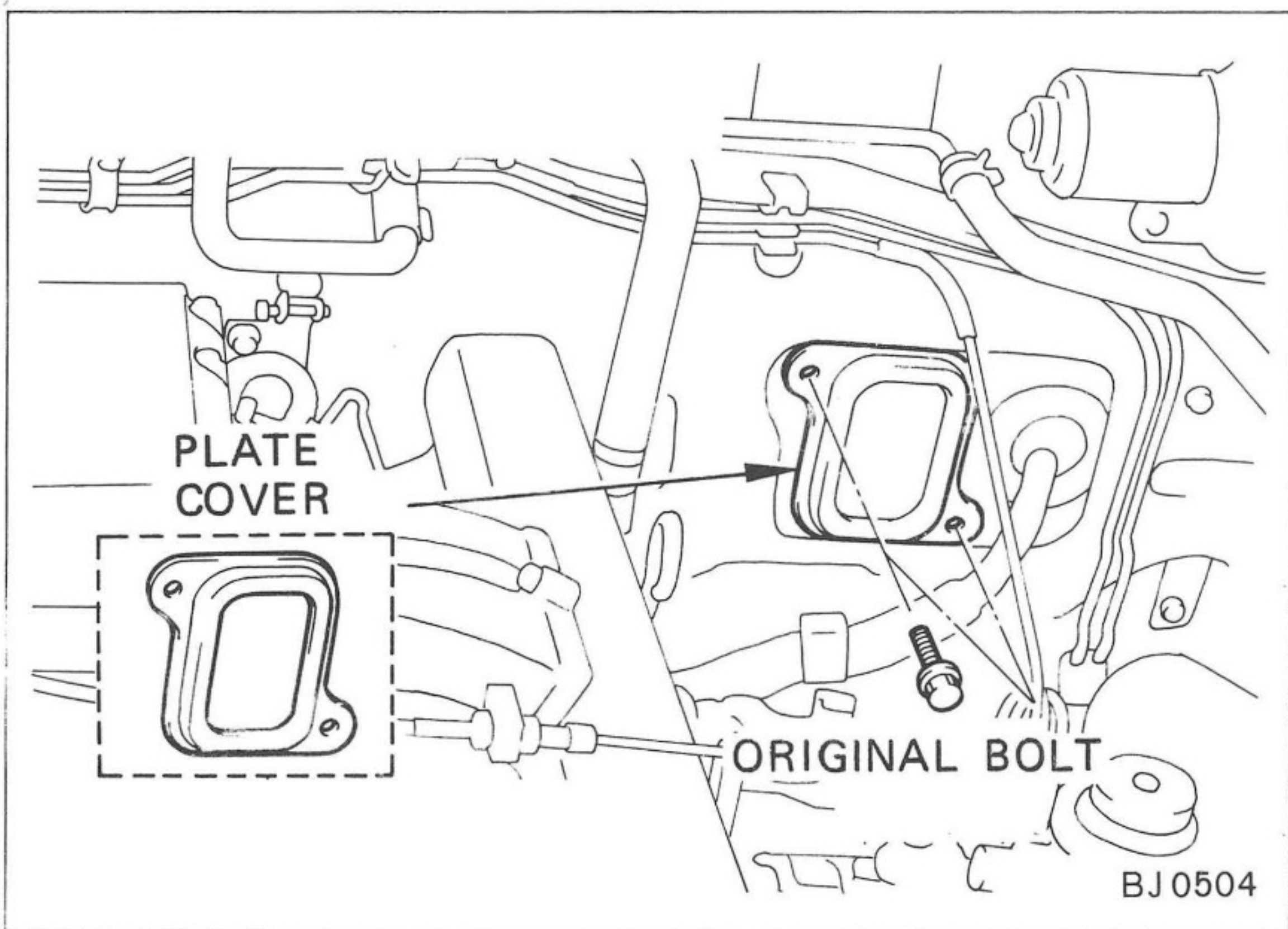

Fig.32

**(2) PLATE COVER**

(a) Install the plate cover supplied in the kit on the bulkhead using two original bolts.

(3) COMPRESSOR

BJ0376

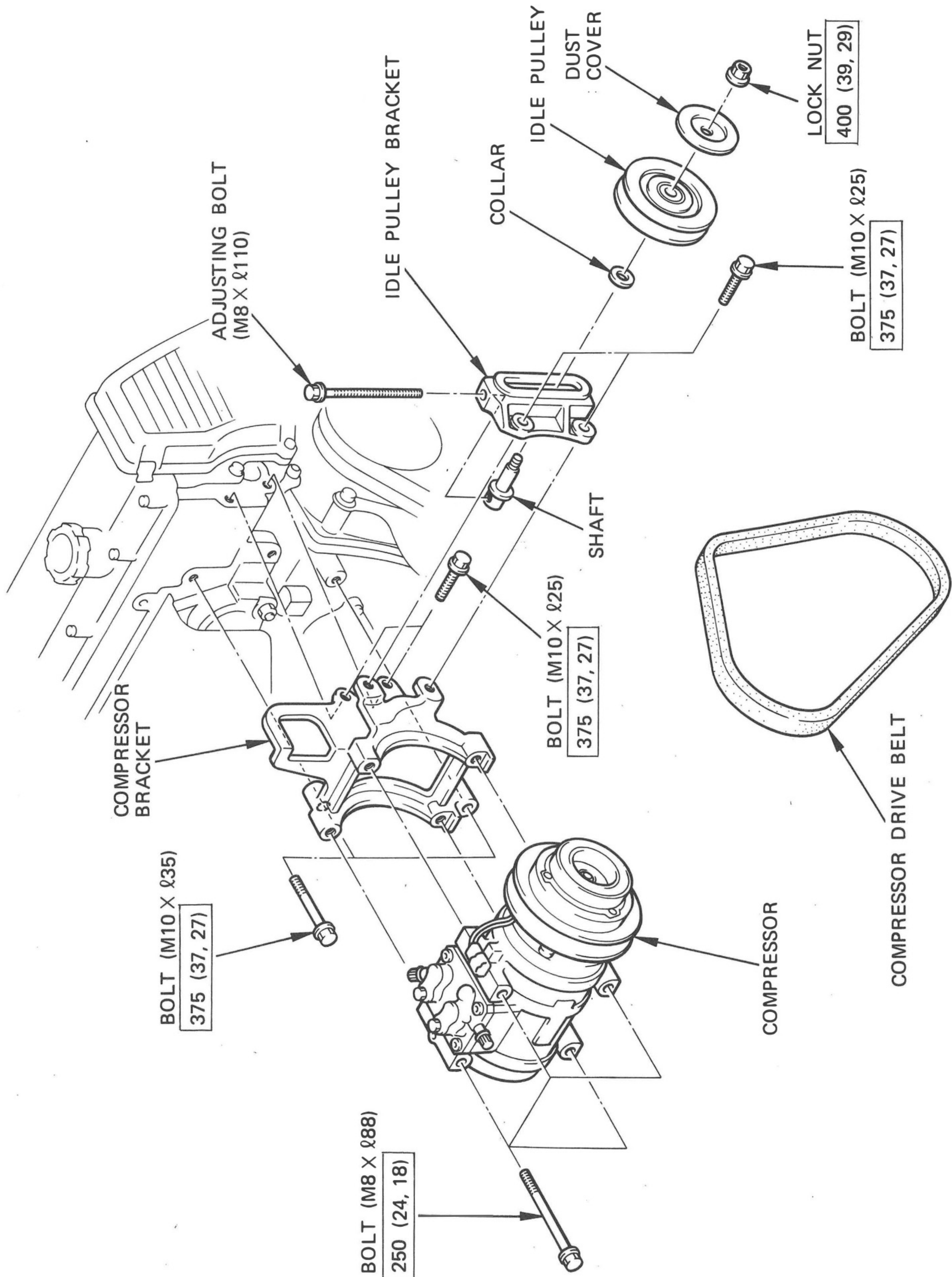

kg·cm (N, m, ft·lbs) : Tightening Torque

Fig.33

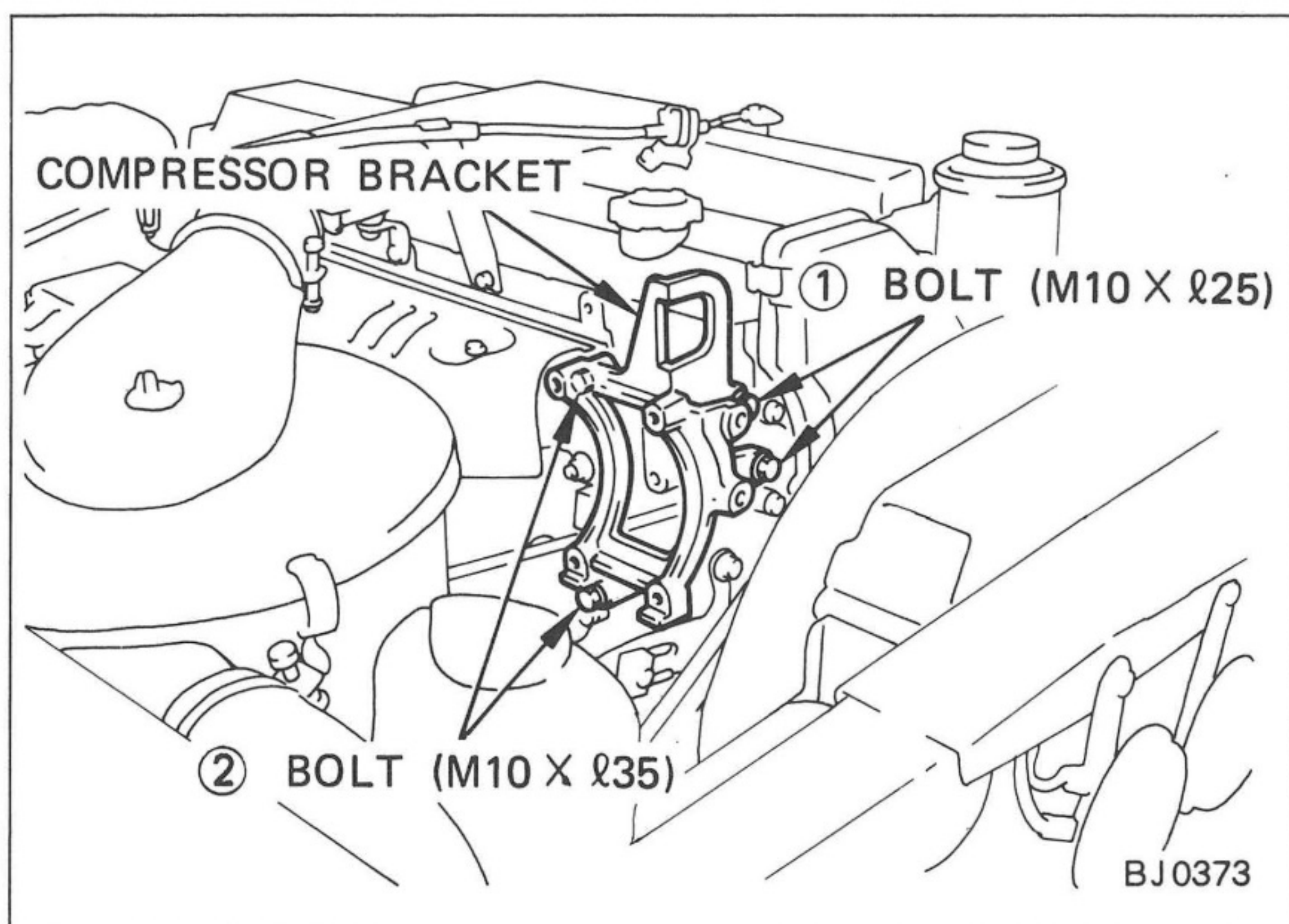

Fig.34

- (a) Install the compressor bracket to the engine block using four bolts.

Tightening Order: ①⇒②

Tightening Torque:

375 kg-cm (37 N-m, 27 ft-lbs)

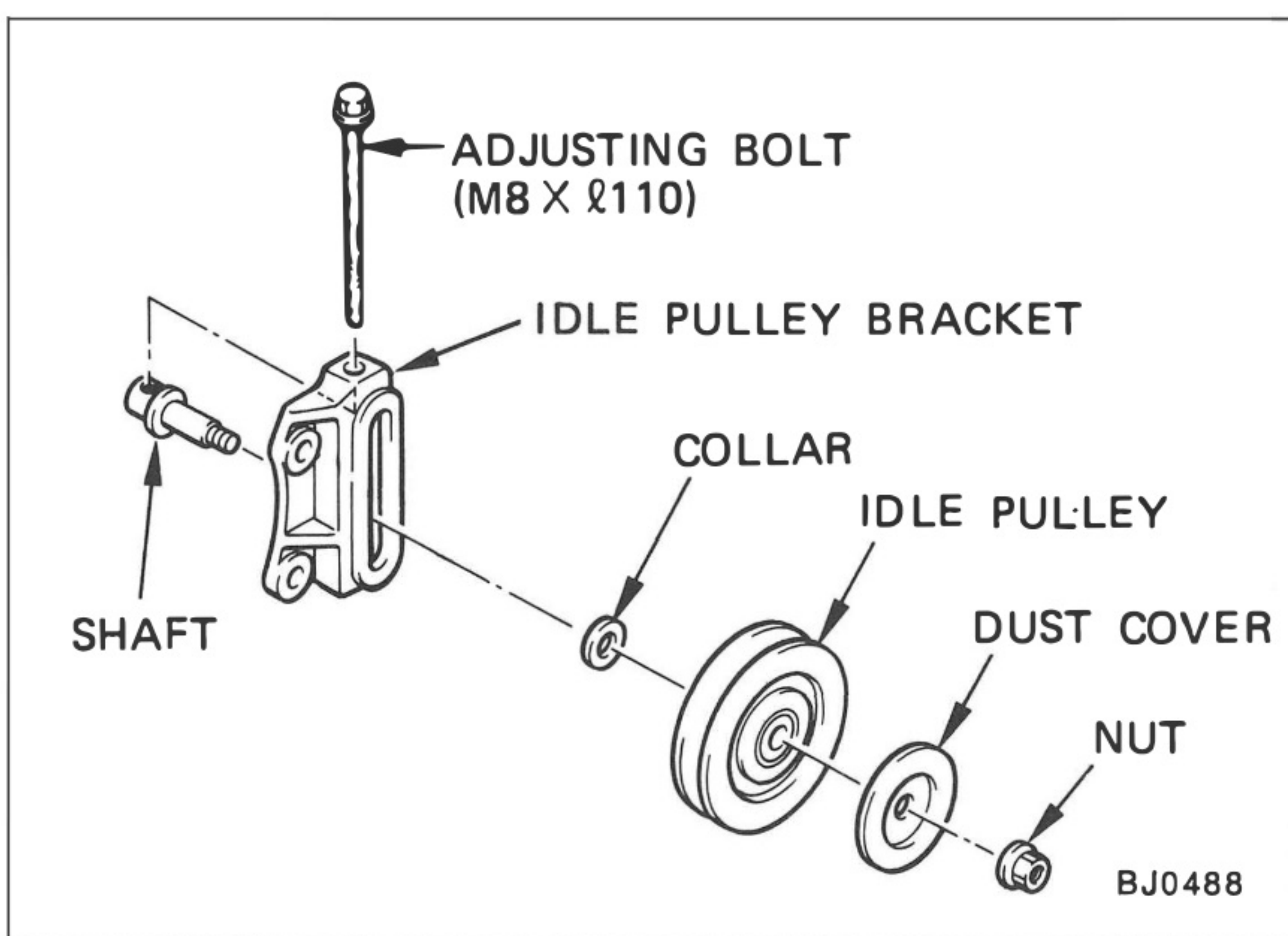

Fig.35

- (b) Assemble the idle pulley and adjusting bolt to the idle pulley bracket.

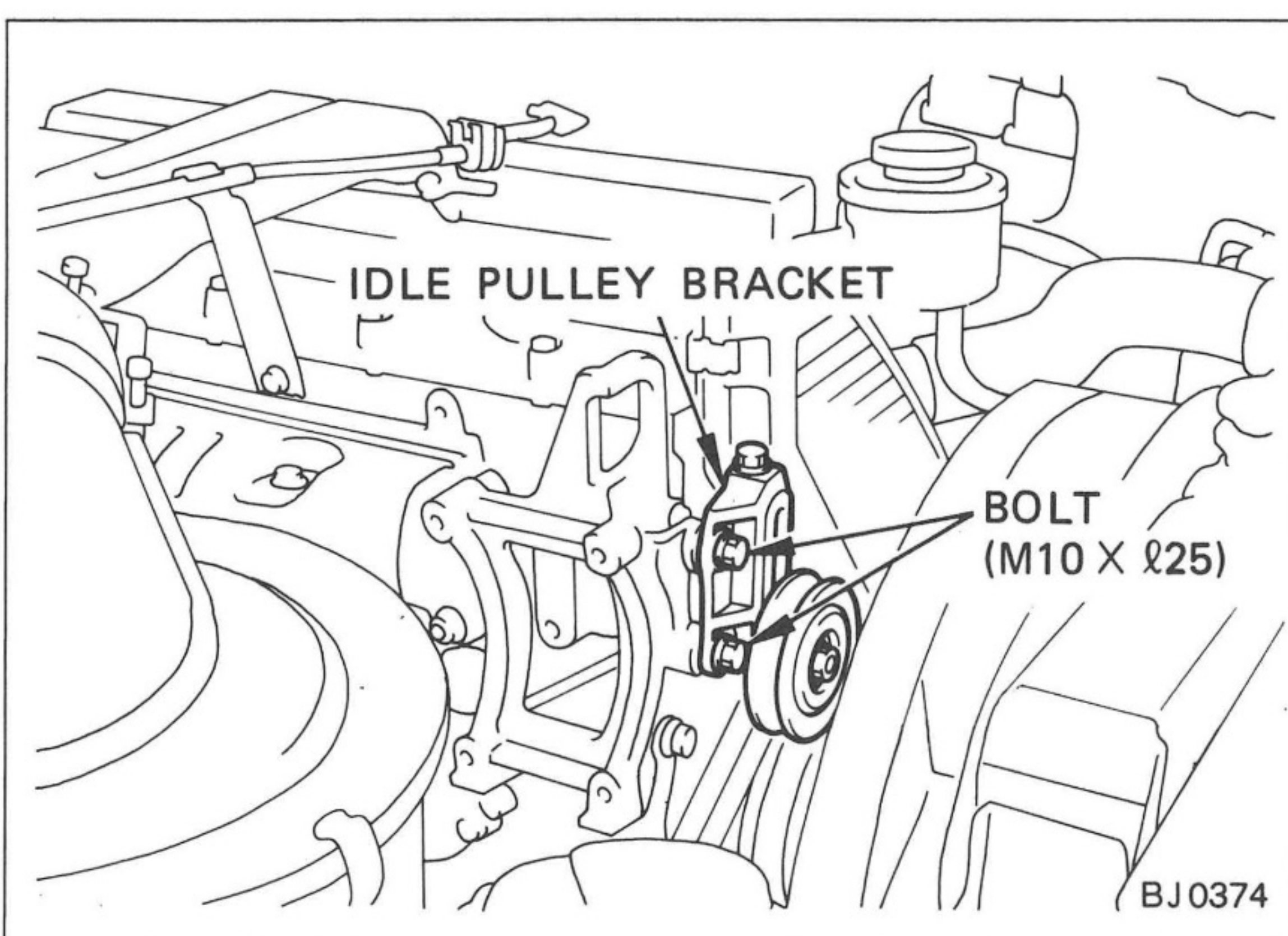

Fig.36

- (c) Install the idle pulley bracket with idle pulley to the compressor bracket using two bolts.

Tightening Torque:

375 kg-cm (37 N-m, 27 ft-lbs)

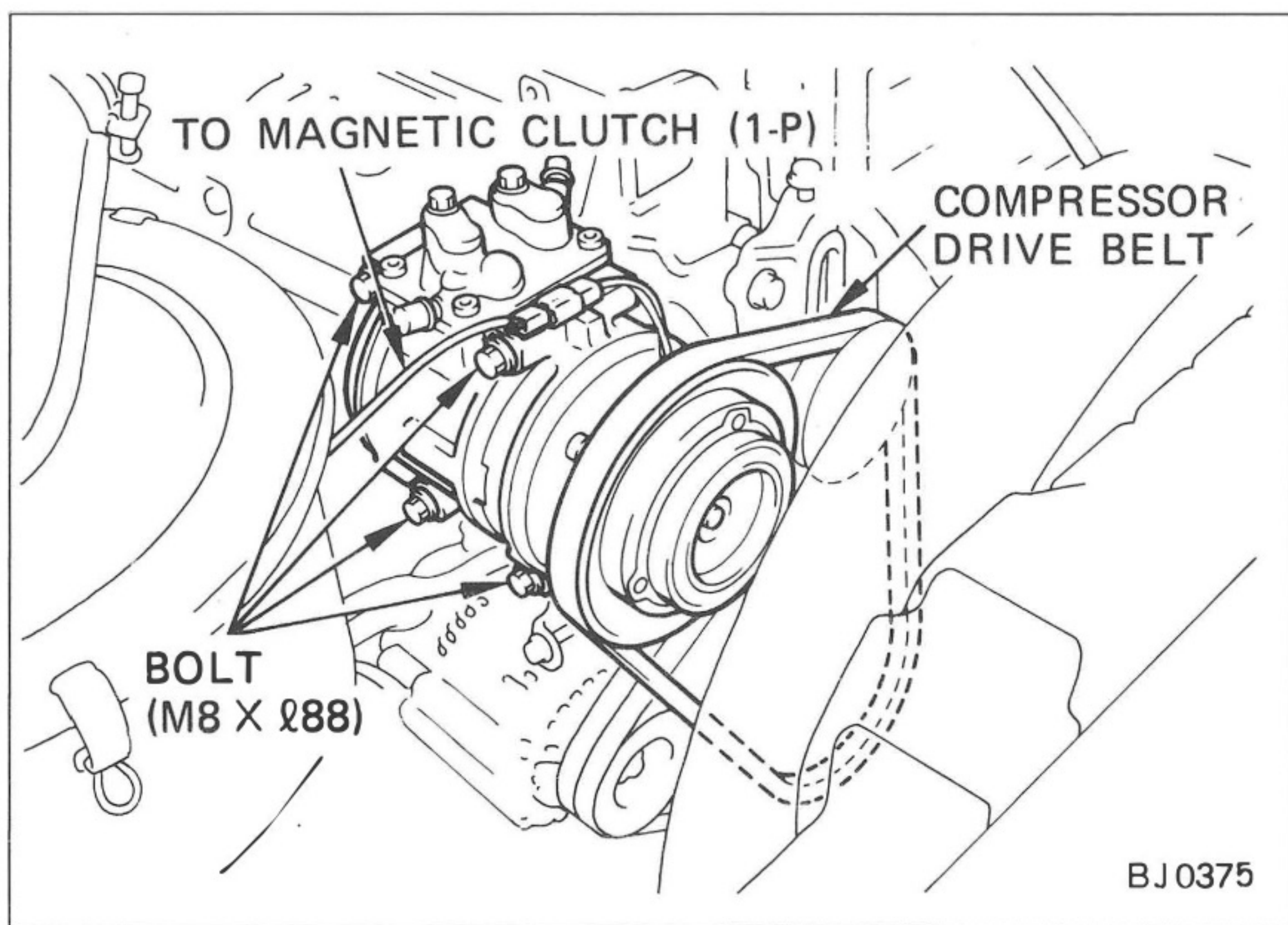

Fig.37

- (d) Install the compressor to the compressor bracket using four bolts.

Tightening Torque :  
250 kg-cm (24 N-m, 18 ft-lbs)

- (e) Connect the vehicle harness to the magnetic clutch lead wire.

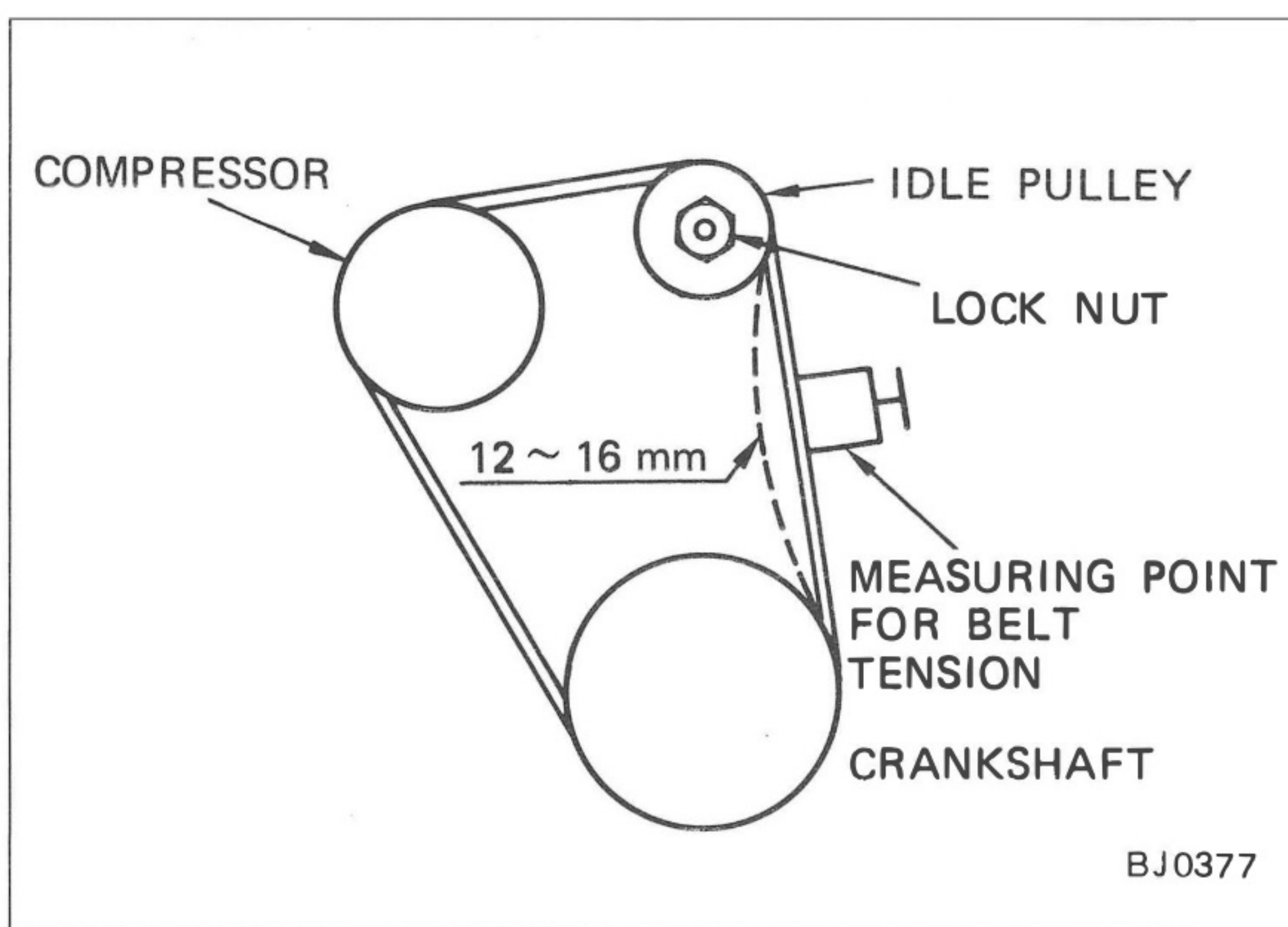

Fig.38

- (f) Install the compressor drive belt, and adjust the belt tension by turning the adjusting bolt.
- (g) Check the belt tension using a Burroughs Drive Belt Tension Gauge (No. BT-33-73F) or a NIPPONDENSO BTG-20.

	Belt deflection at 10kg (22lbs) force	Belt tension using the belt tension gauge
NEW BELT	12 - 16 mm (0.47-0.62 inch)	50 ± 10 kg (110 ± 22 lbs)
USED BELT	16 - 22 mm (0.62-0.86 inch)	30 ± 10 kg (66 ± 22 lbs)

- (h) Tighten the lock nut.

Tightening Torque :  
400 kg-cm (39 N-m, 29 ft-lbs)

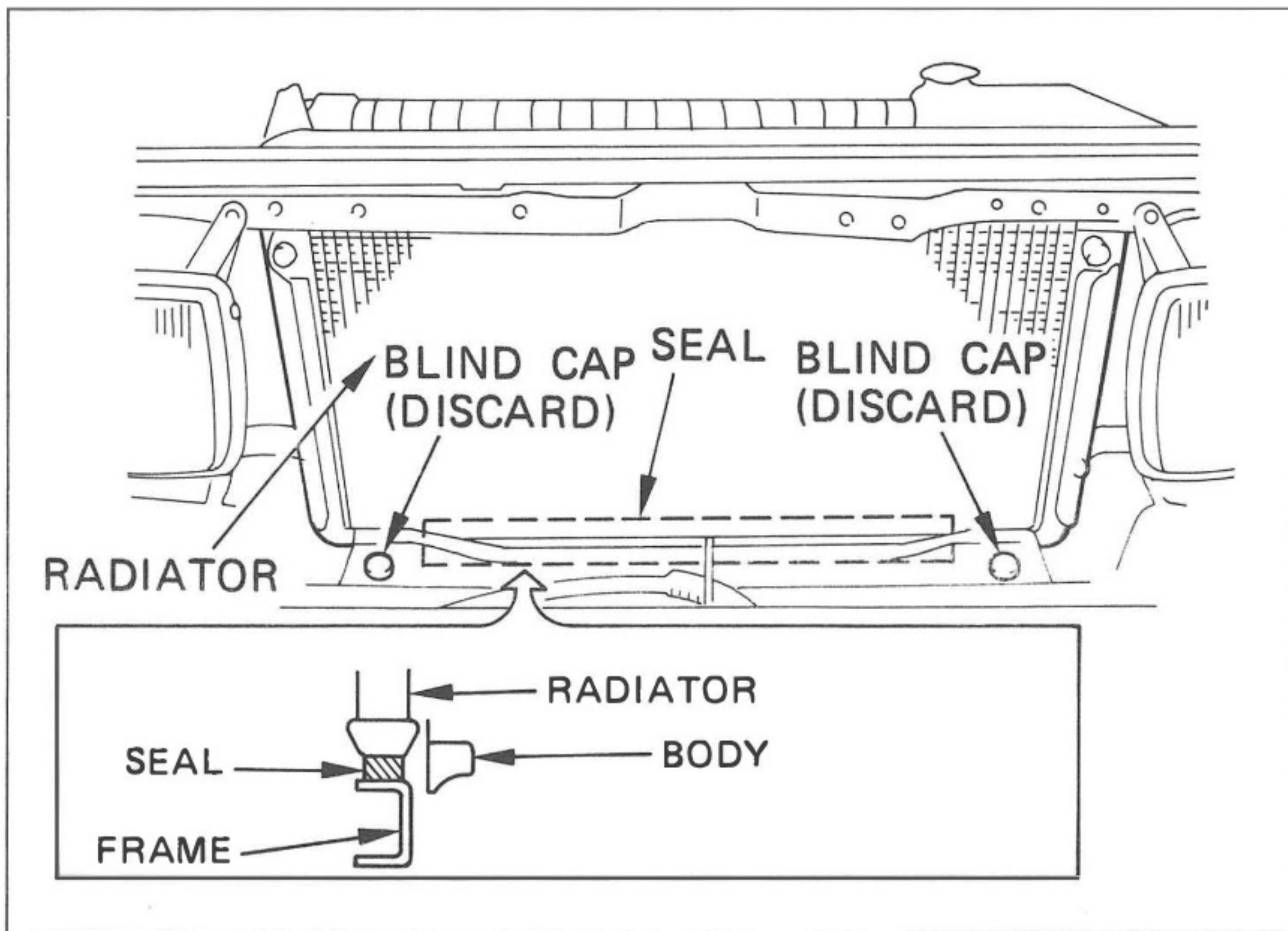

Fig.39

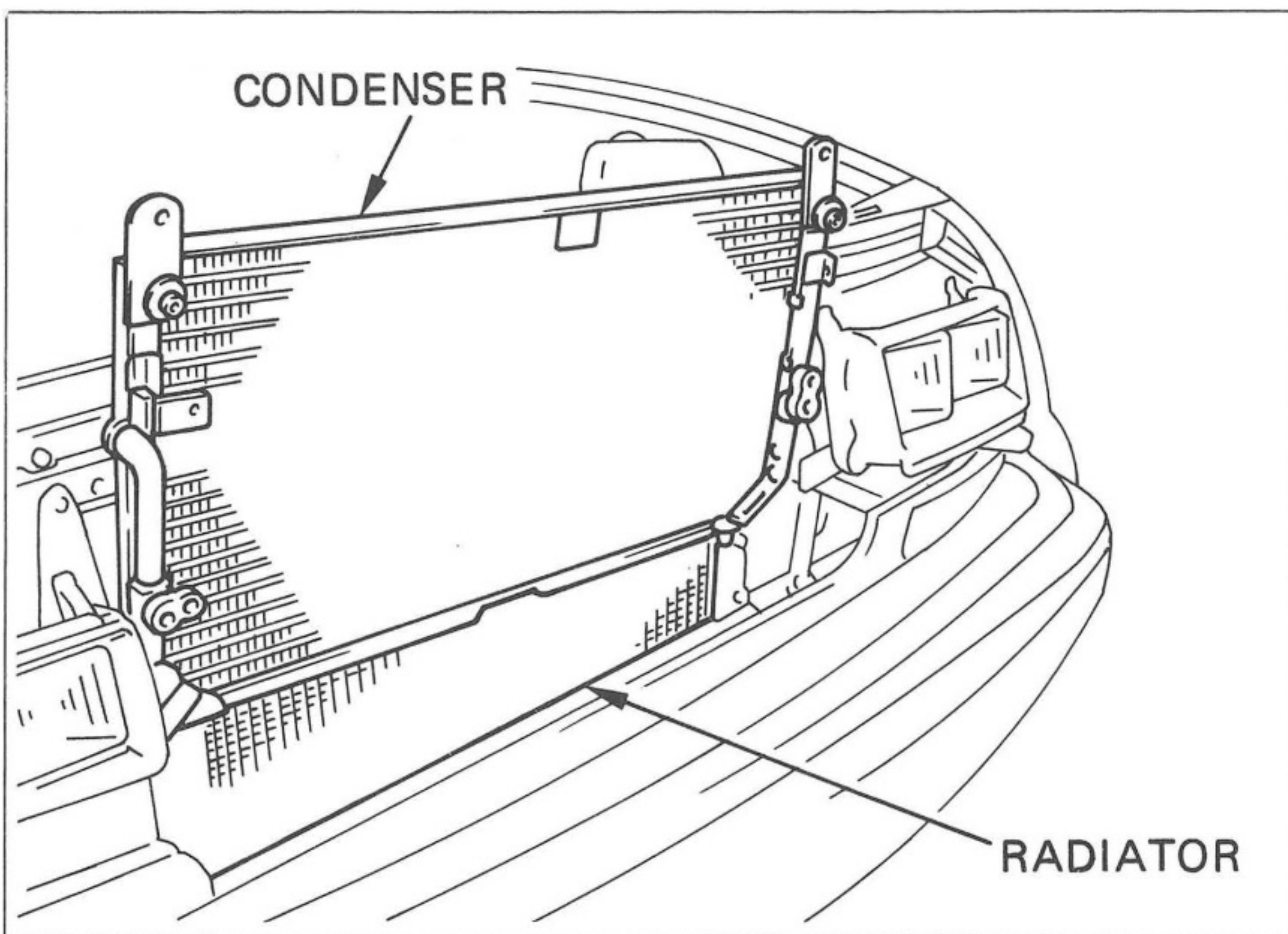

Fig.40

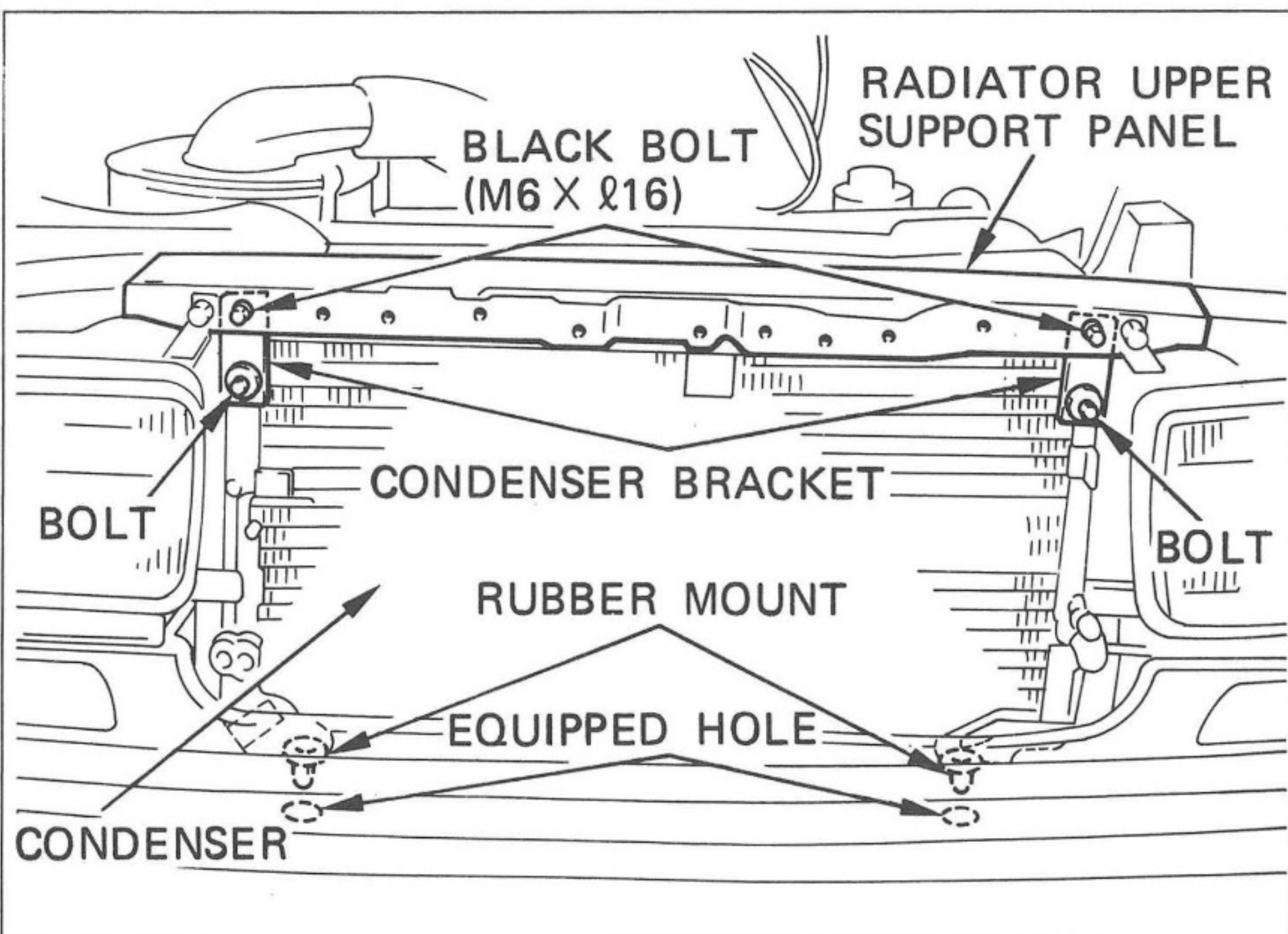

Fig.41

#### (4) CONDENSER

- (a) Attach the seal to the bottom of radiator as shown.
- (b) Remove and discard the blind caps from the frame.

- (c) Slide in the condenser and gently manoeuvre it into its position where the lower mounts slot into the chassis rail.

- (d) Reinstall the radiator upper support panel and connect the horn harness to the horns, and clip in the vehicle harness to the radiator upper support panel.
- (e) Fasten the two condenser brackets to the radiator upper support panel using two bolts.
- (f) Fasten the two condenser brackets to the condenser.

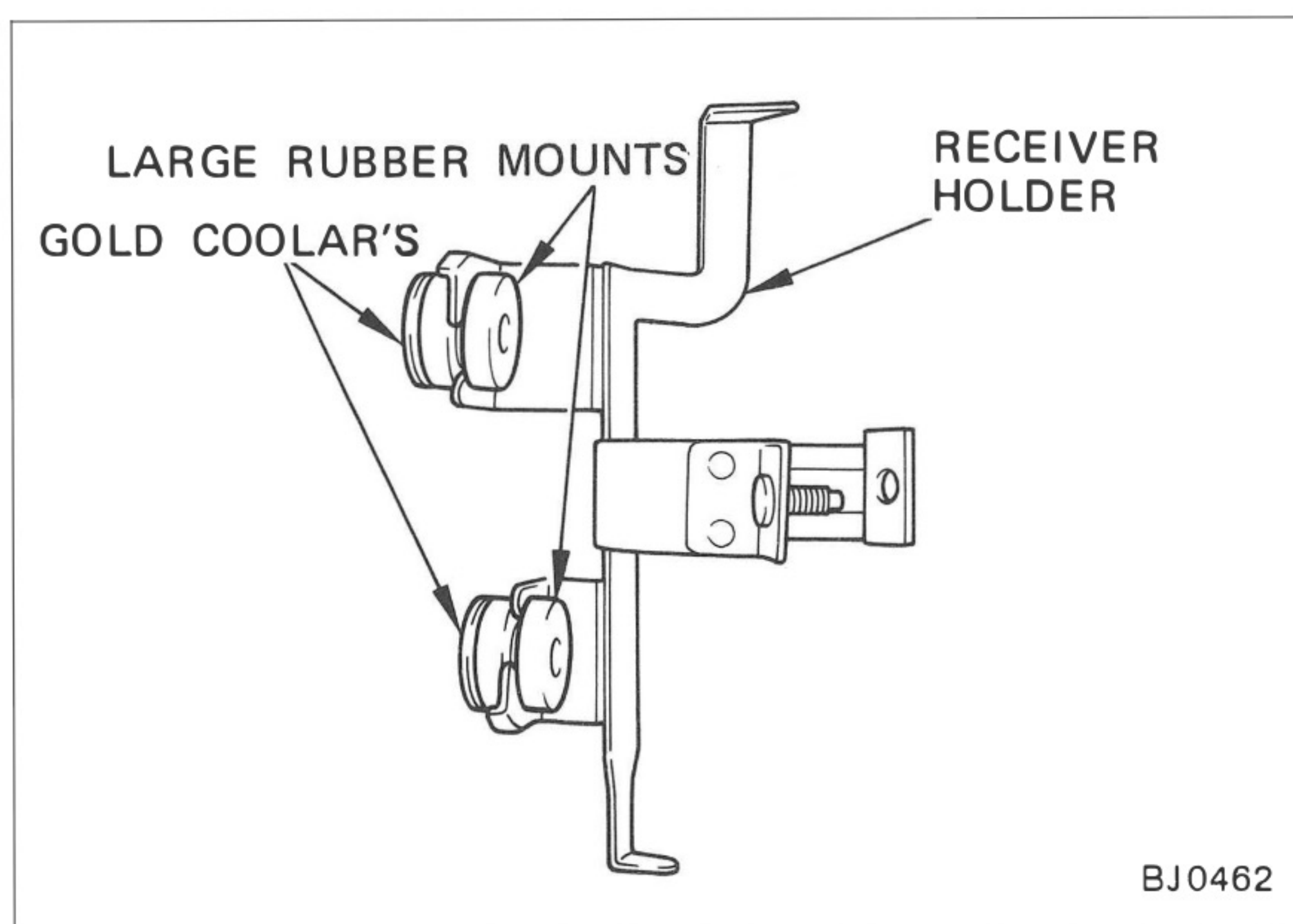

Fig.42

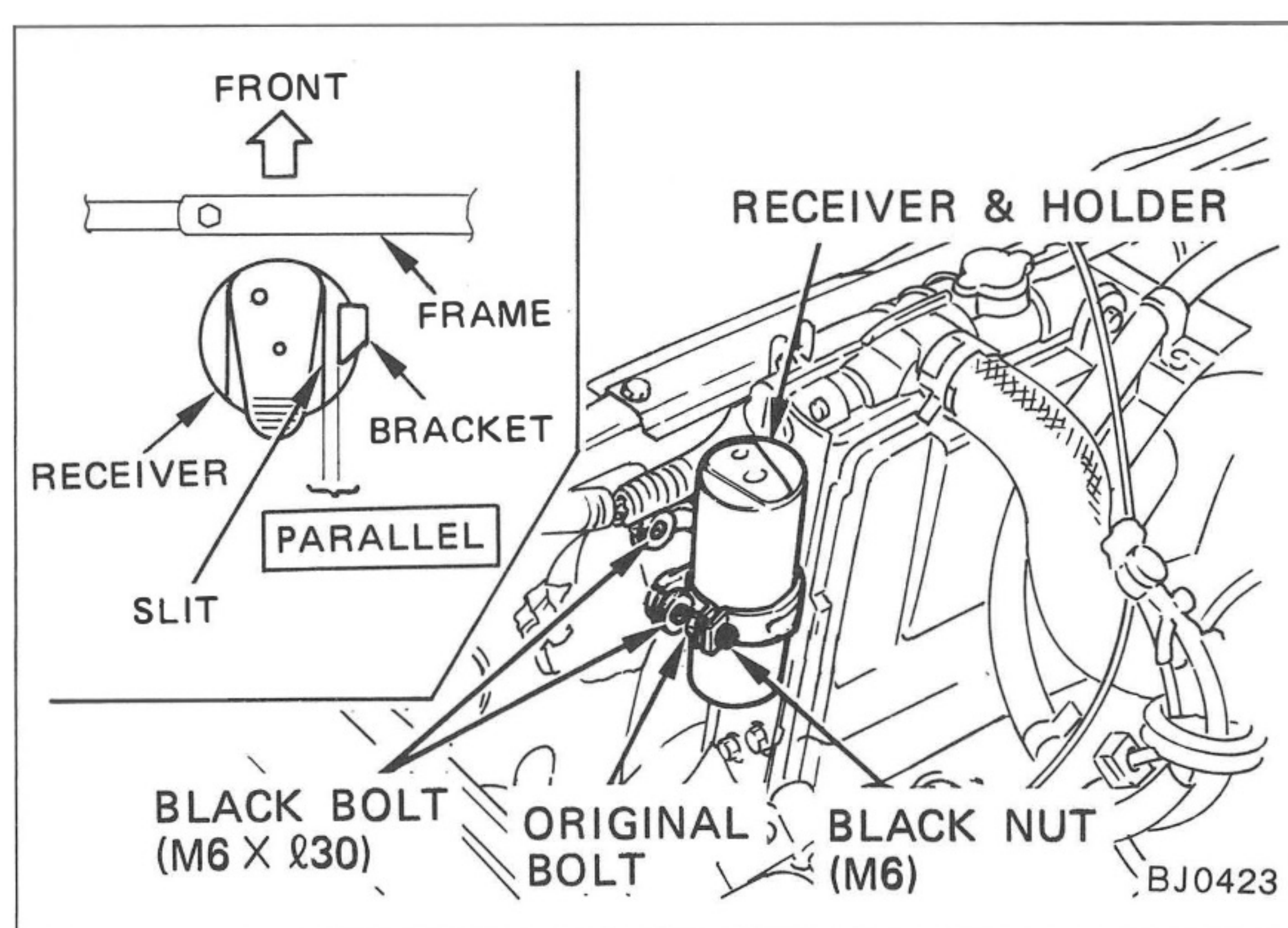

Fig.43

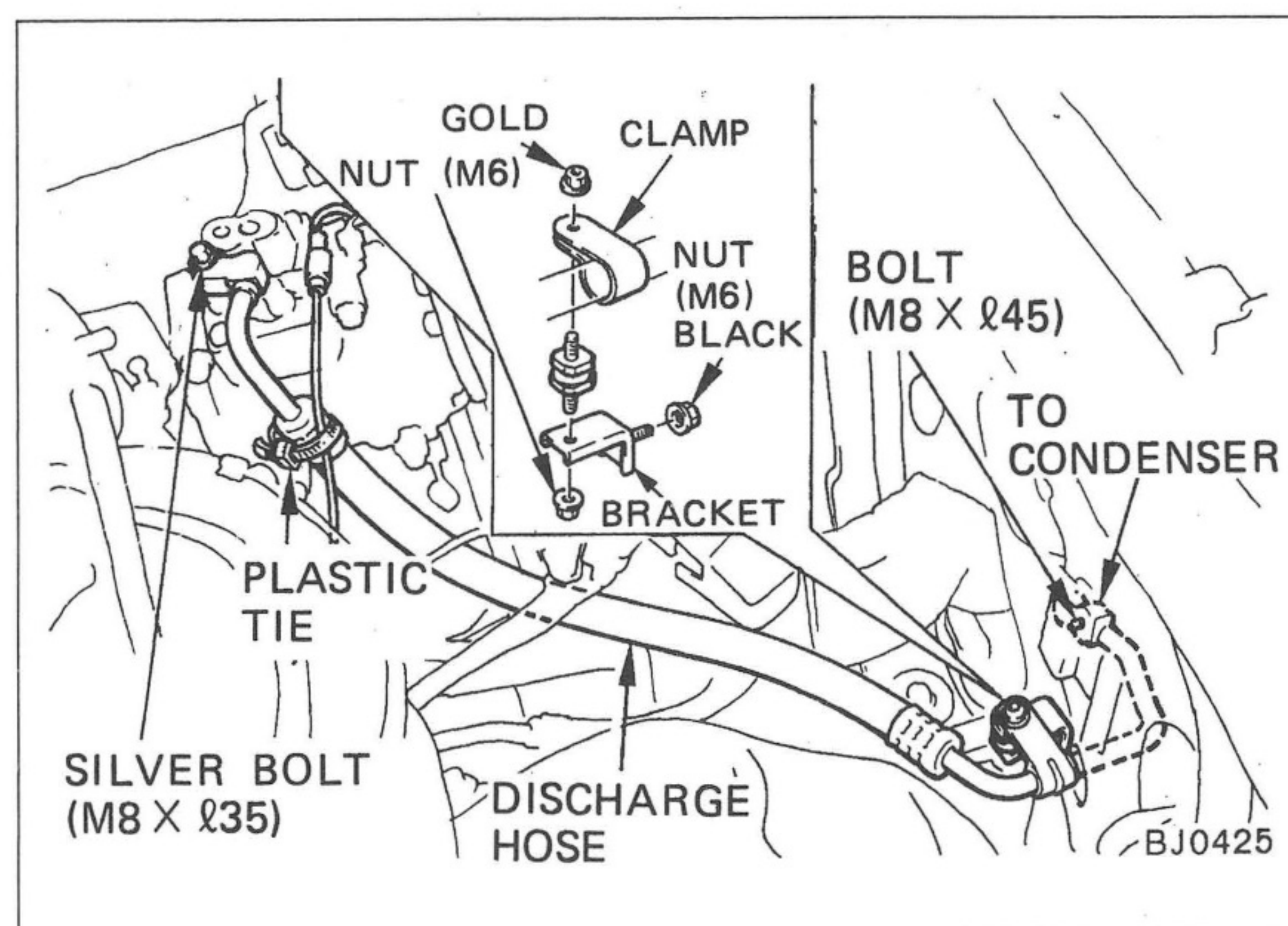

Fig.44

## (5) RECEIVER

- (a) Assemble two large rubber mounts and two gold collars to the receiver holder as shown.

- (b) Install the receiver holder to the radiator support panel using two bolts.
- (c) Position the receiver drier in the holder and fasten with a nut.

## (6) DISCHARGE HOSE

- (a) Assemble the clamp, rubber mount, and bracket to the discharge hose.
- (b) Connect the discharge hose to the condenser.  
Tightening Torque:  
185 kg-cm (18 N-m, 13 ft-lbs)
- (c) Connect the discharge hose to the compressor.  
Tightening Torque:  
250 kg-cm (24 N-m, 18 ft-lbs)
- (d) Connect the vehicle harness to the magnetic clutch lead wire and secure it to the discharge hose using a plastic tie.
- (e) Fasten the clamp to the radiator support panel using a nut.

### HINT

Temporarily remove the front R.H.S. indicator assembly to gain access to the black M6 nut.

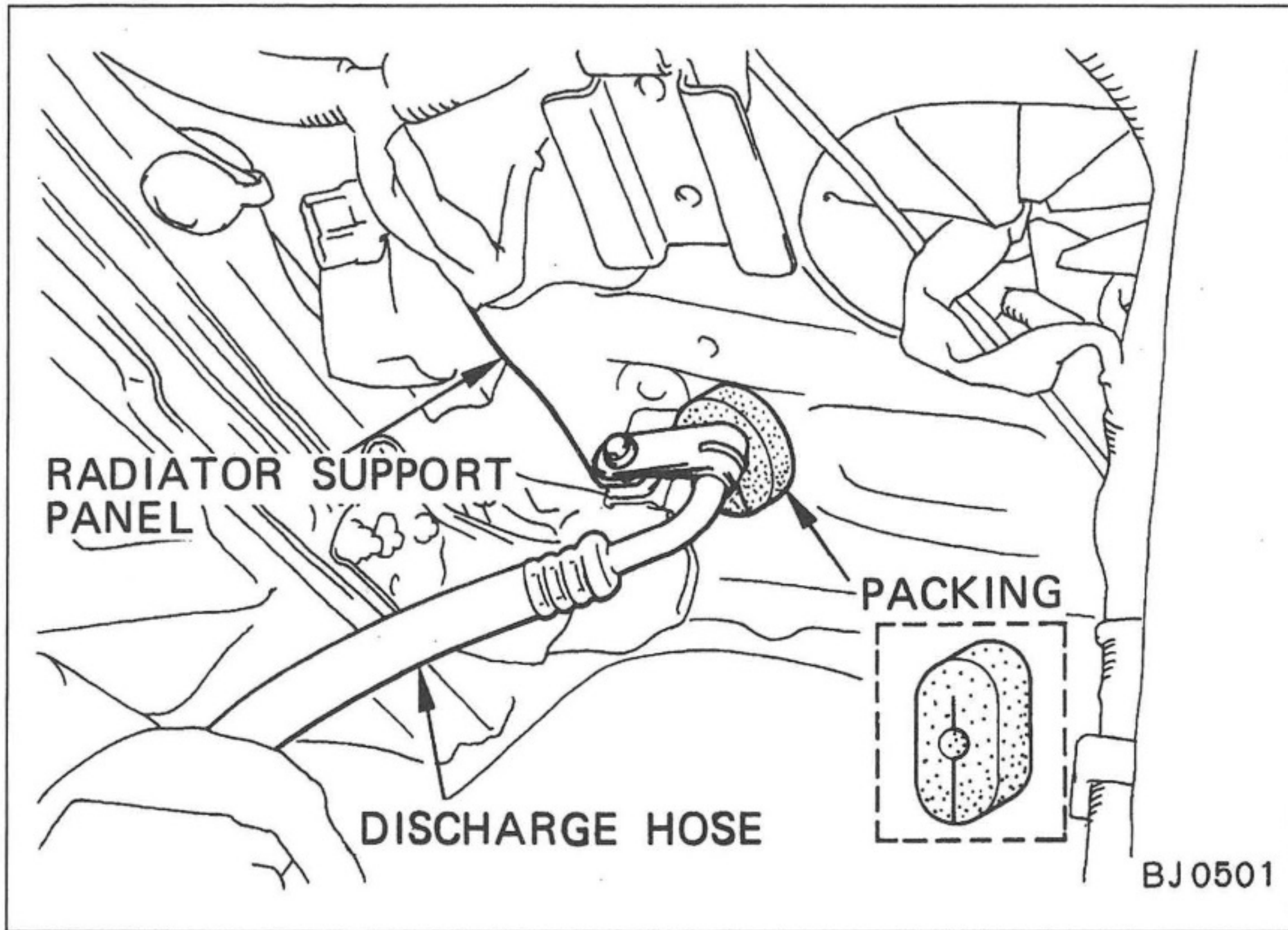

Fig.45

(f) Install packing to the radiator support panel.

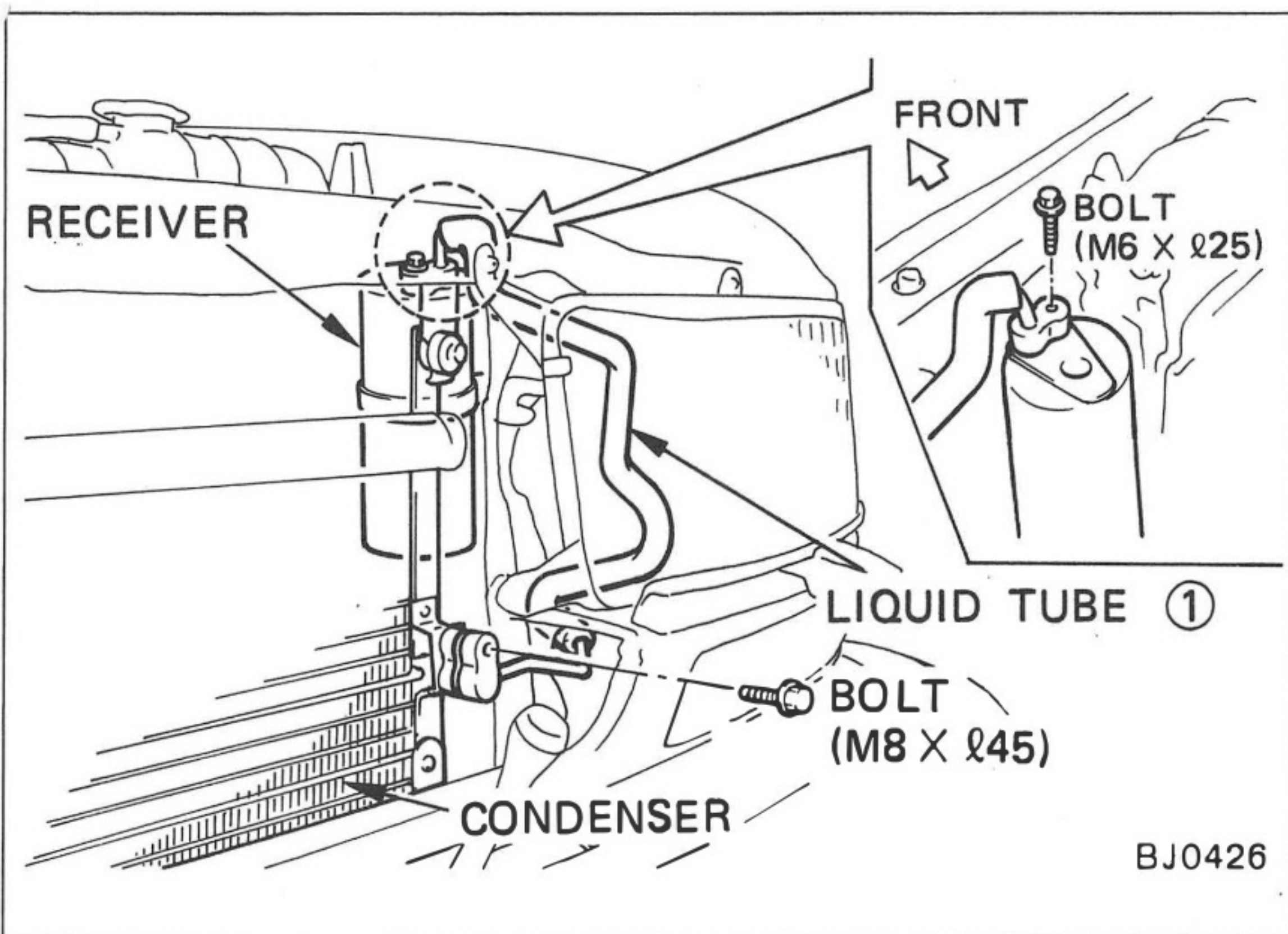

Fig.46

**(7) LIQUID TUBE**

(a) Connect the liquid tube ① from receiver to condenser.

Tightening Torque: Receiver side  
55 kg-cm (5.4 N-m, 4.0 ft-lbs)

Tightening Torque: Condenser side  
185 kg-cm (18 N-m, 13 ft-lbs)

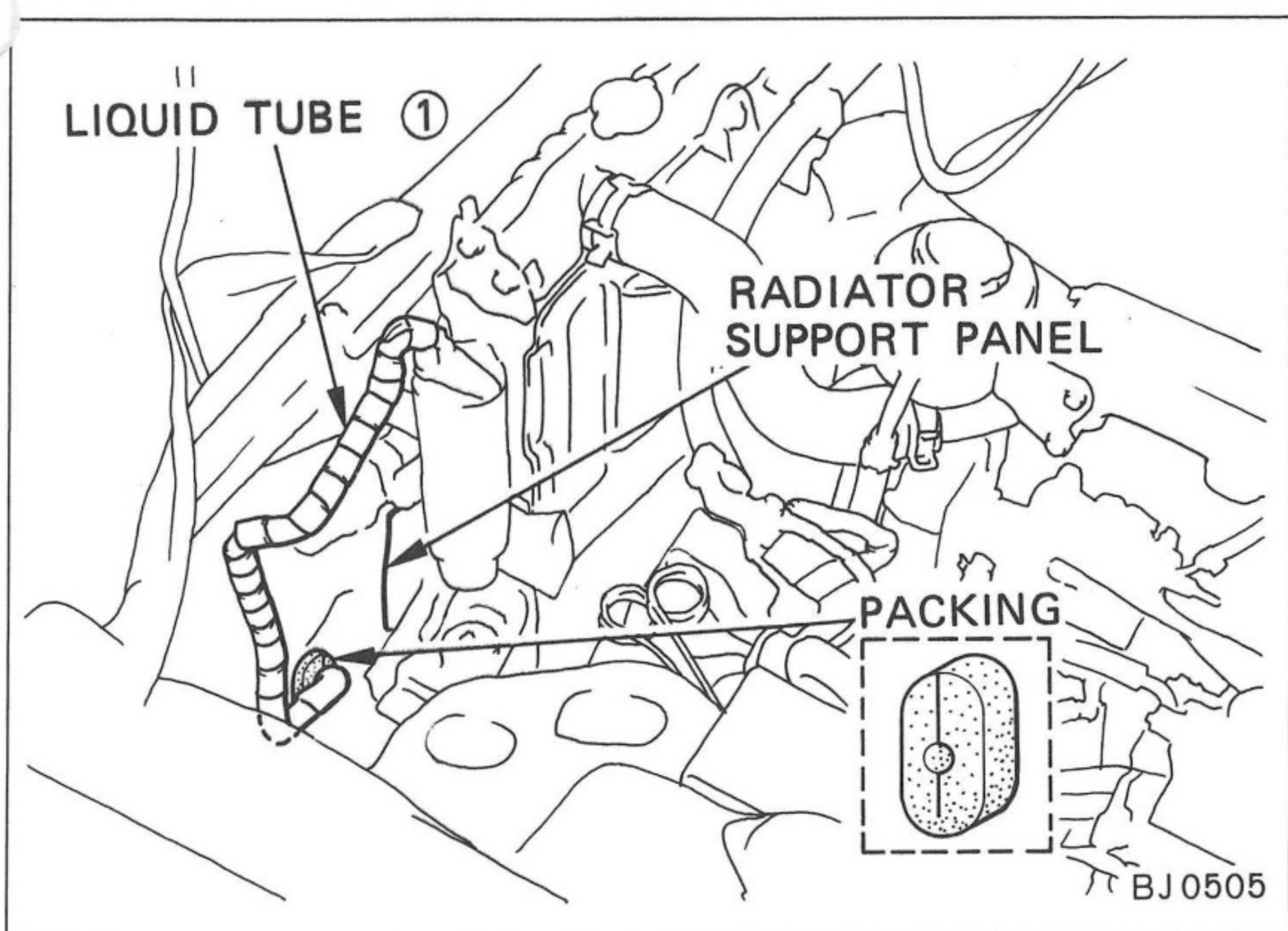

Fig.47

(b) Install the packing into the radiator support panel.

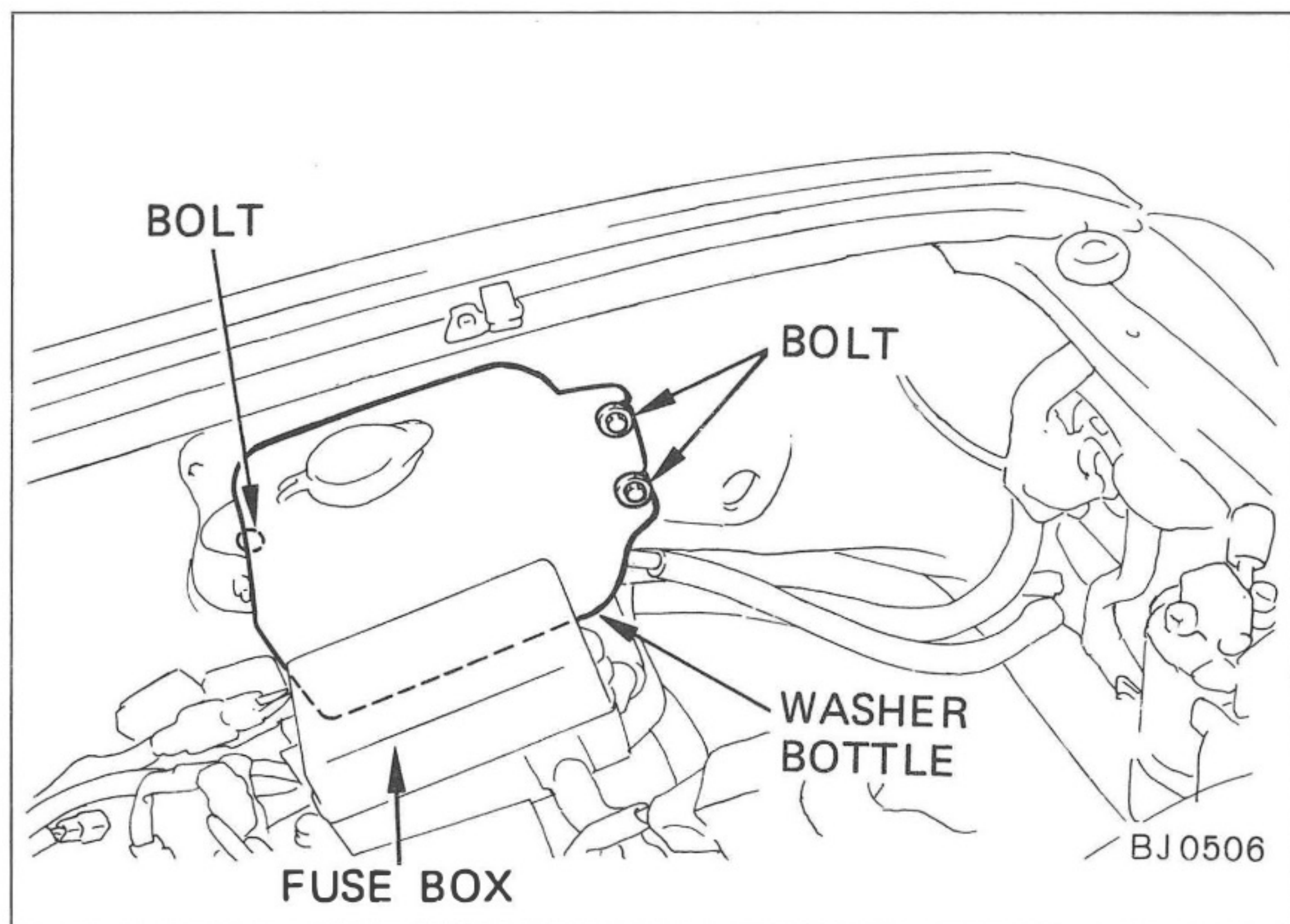

Fig.48

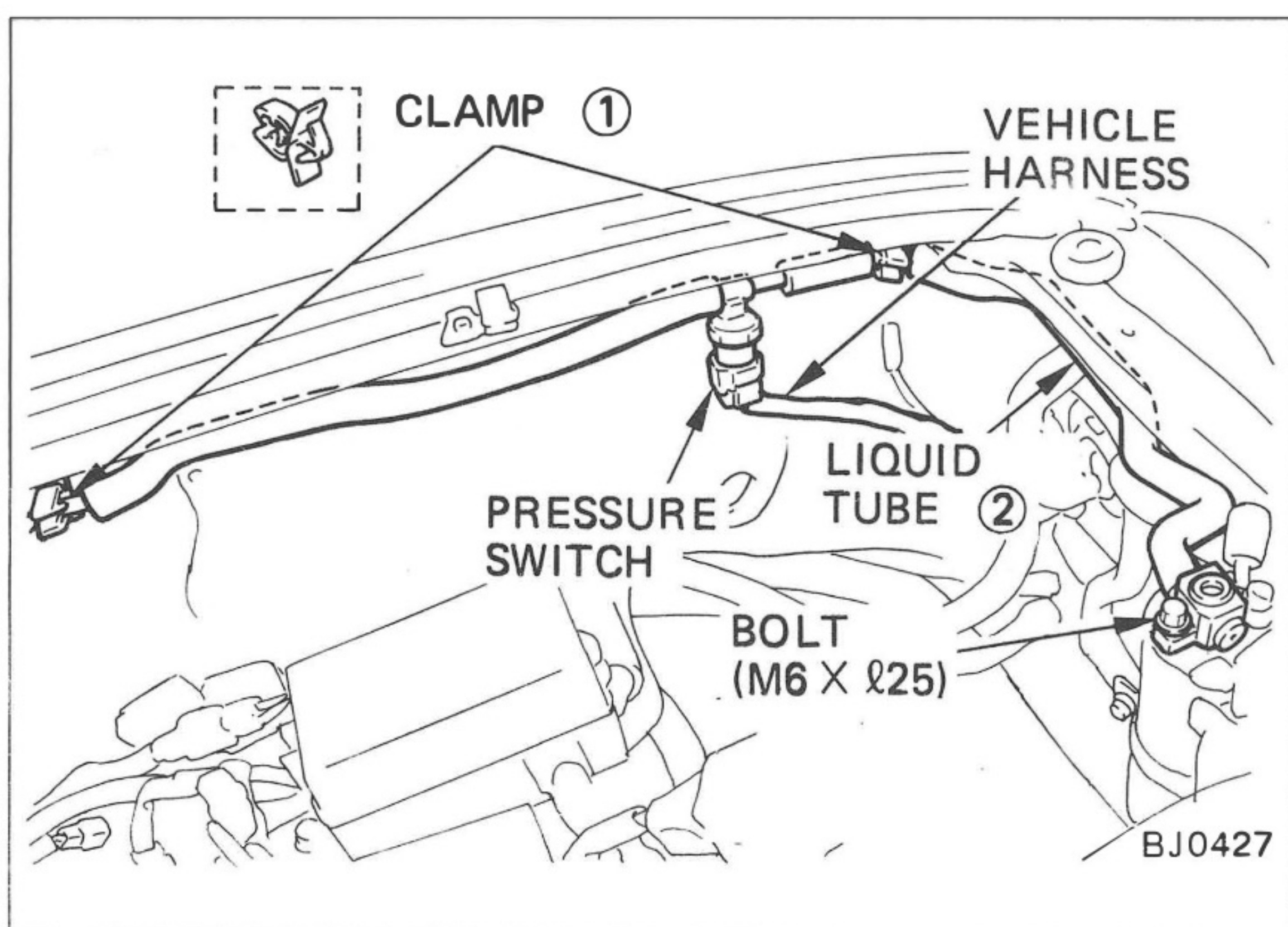

Fig.49

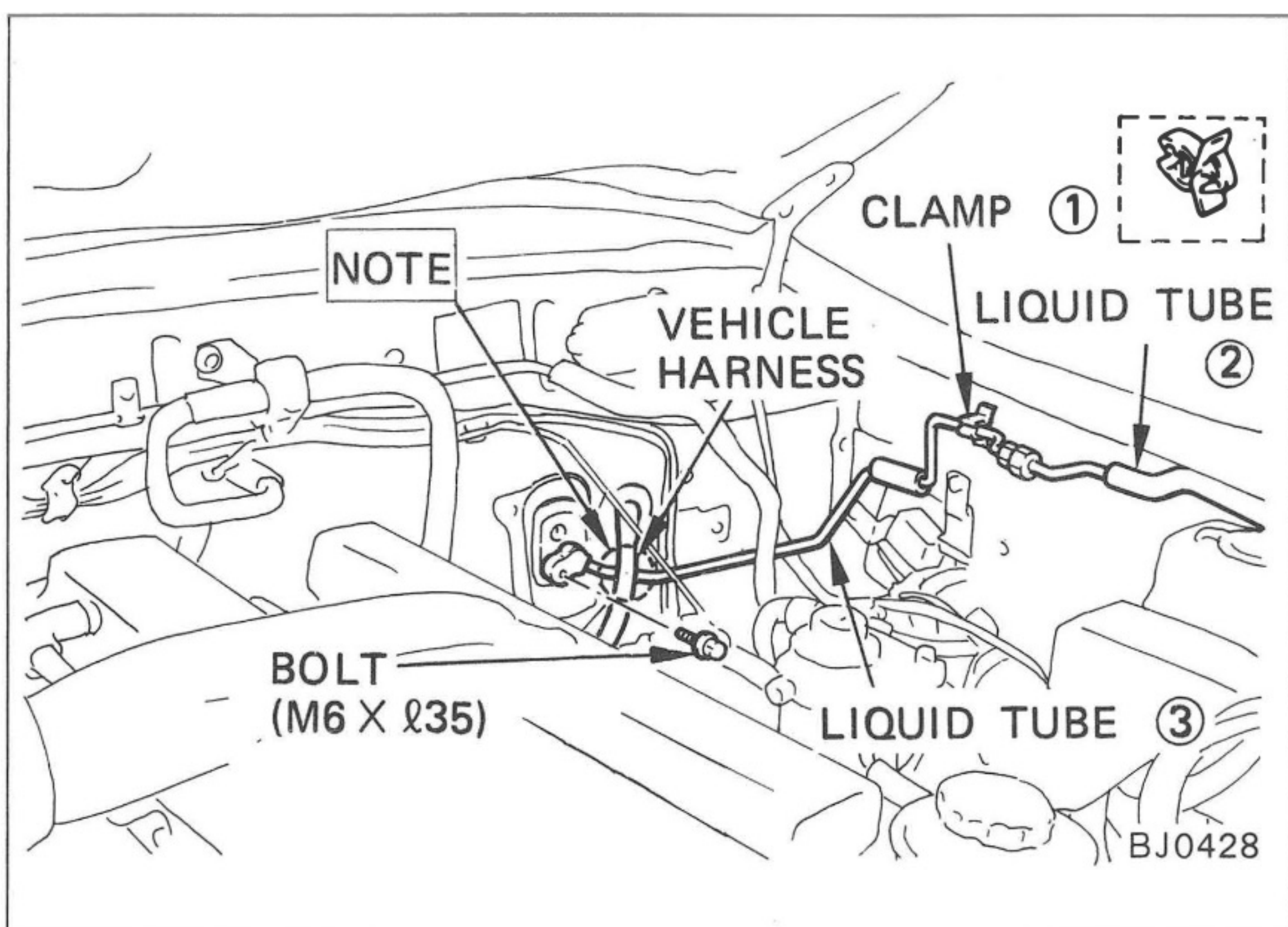

Fig.50

- (c) Temporarily remove the fuse box and washer bottle.

- (d) Install two clamp ① to the left side inner guard.
- (e) Connect the liquid tube ② to receiver.

Tightening Torque: Receiver side  
55 kg-cm (5.4 N-m, 4.0 ft-lbs)

- (f) Fasten the liquid tube ② to the clamp ①.
- (g) Connect the vehicle harness to the pressure switch.

**NOTE**

The 4-P connector is located behind the L.H.S. headlight.

- (h) Install a clamp ① to the left side inner guard.
- (i) Connect the liquid tube ③ from cooling unit to liquid tube ②.

Tightening Torque: Receiver side  
55 kg-cm (5.4 N-m, 4.0 ft-lbs)

**NOTE**

Route the liquid tube ③ beneath the vehicle harness.

- (j) Fasten the liquid tube ③ to the clamp ①.

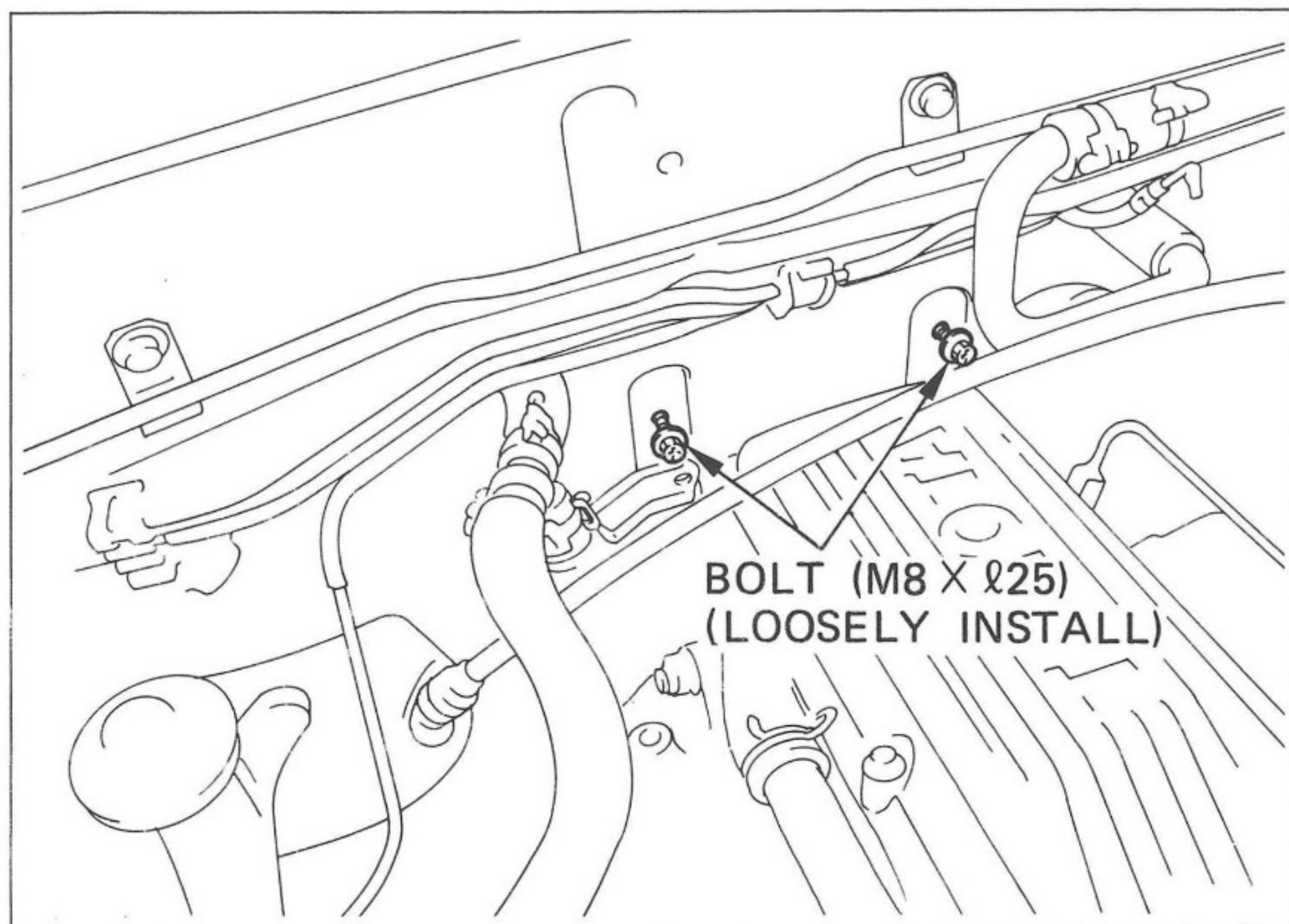

Fig.51

## (8) SUCTION TUBE

- (a) Loosely install two bolts in place of the original bolts in bulkhead as shown.

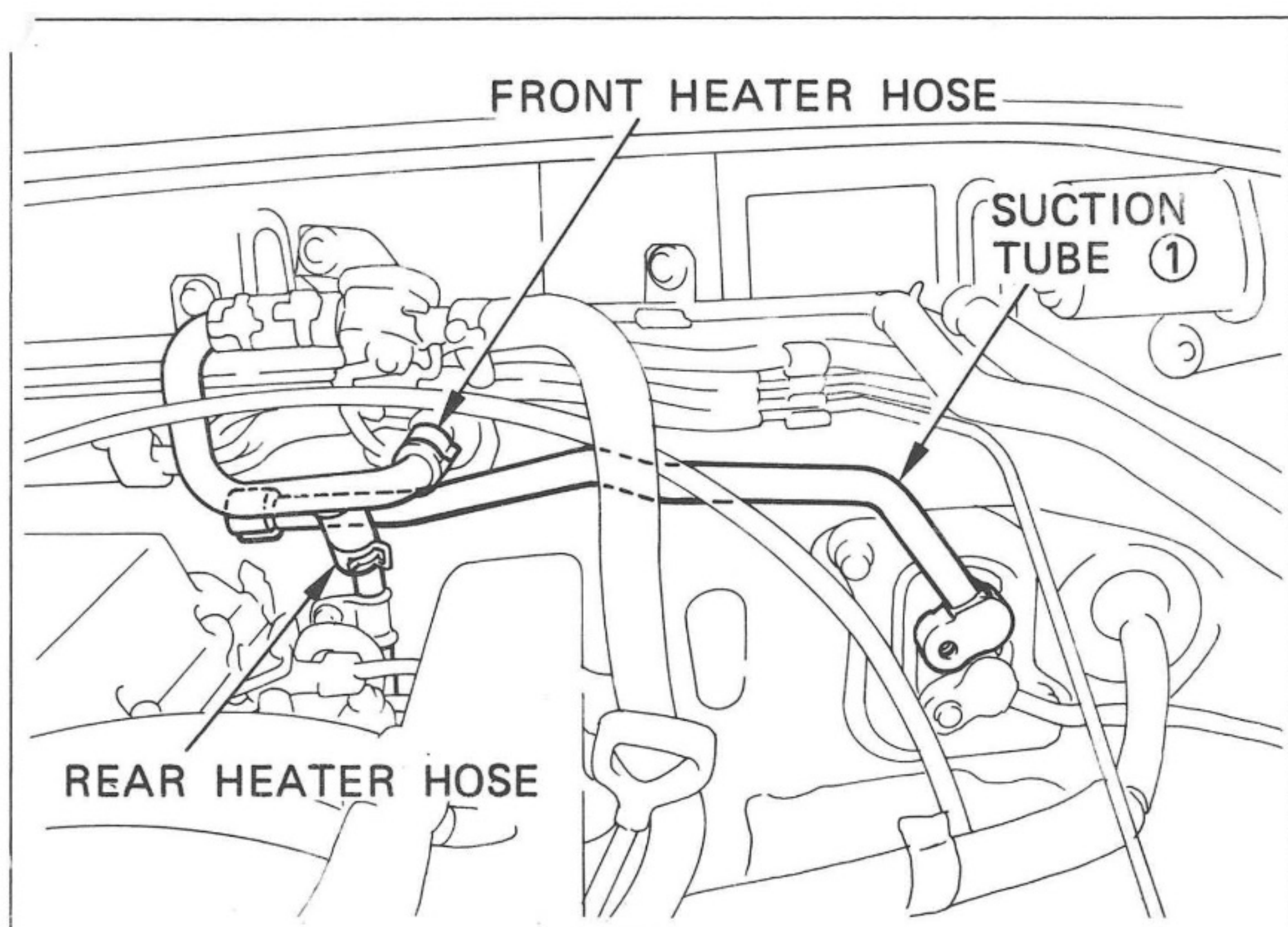

Fig.52

- (b) Route the suction tube ① between the front heater hose and rear heater hose.

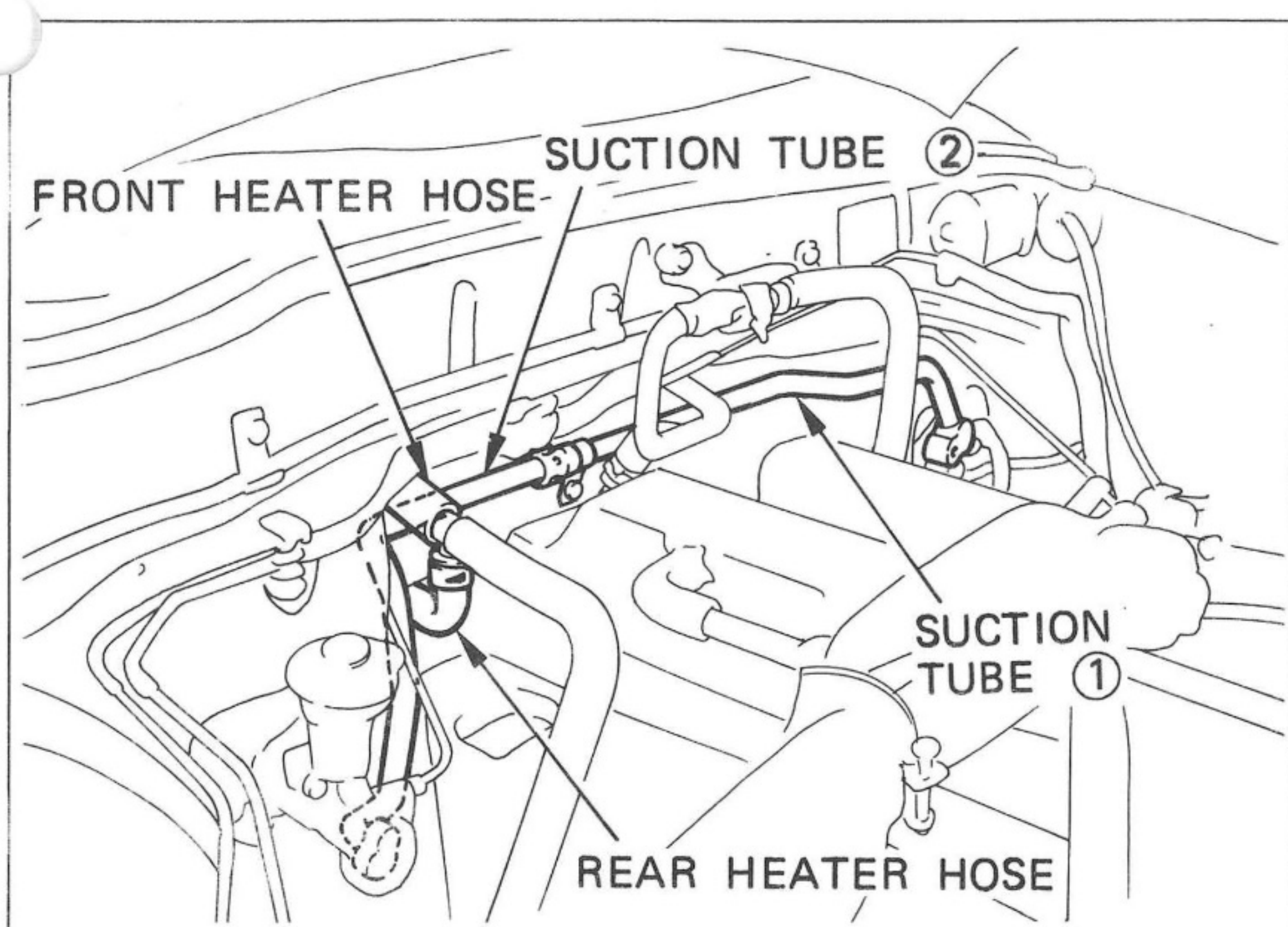

Fig.53

- (c) Route the suction tube ② between the front heater hose and rear heater hose.

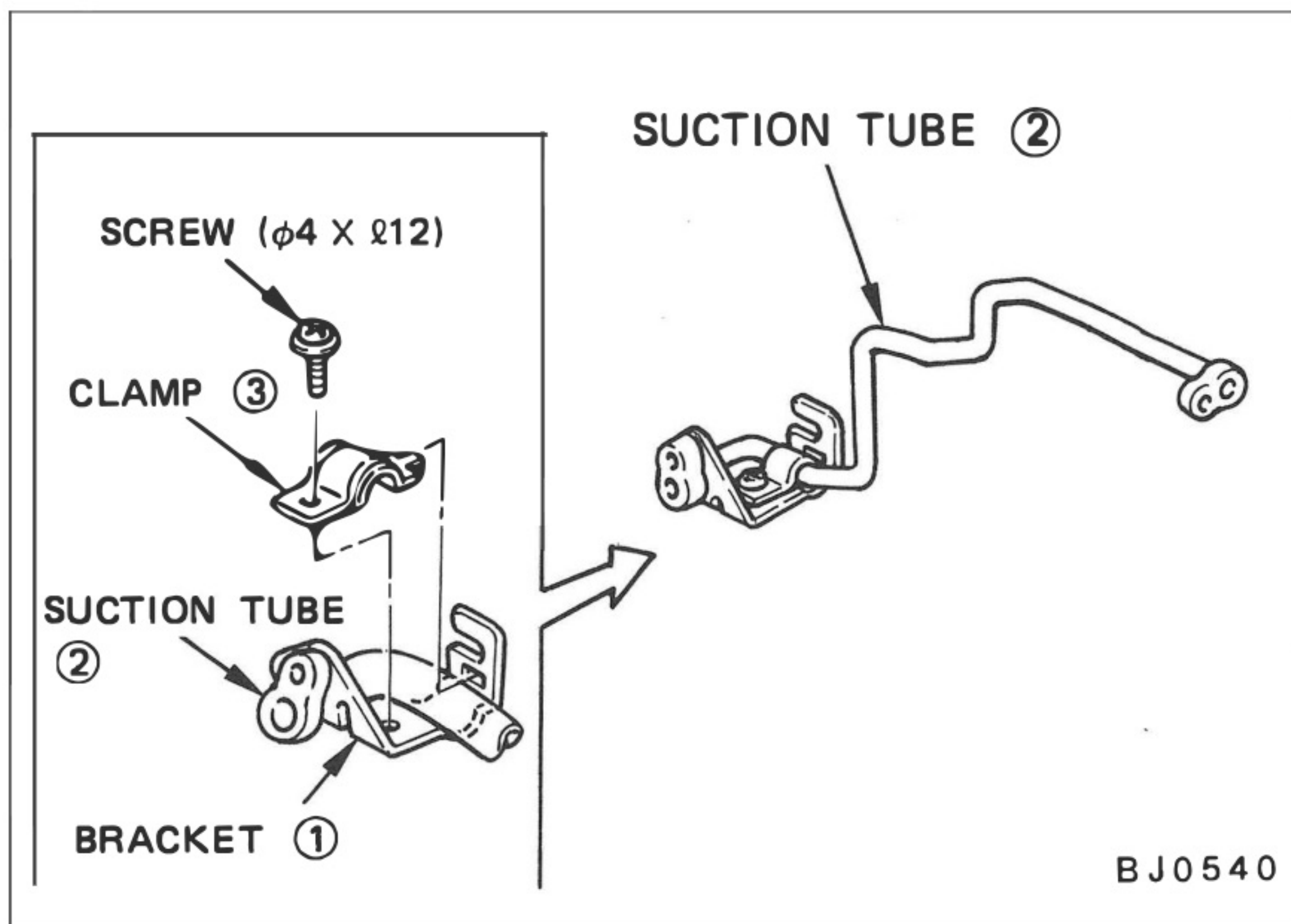

Fig.54

- (d) Install the bracket ① and clamp ③ to the suction tube ② using a screw.

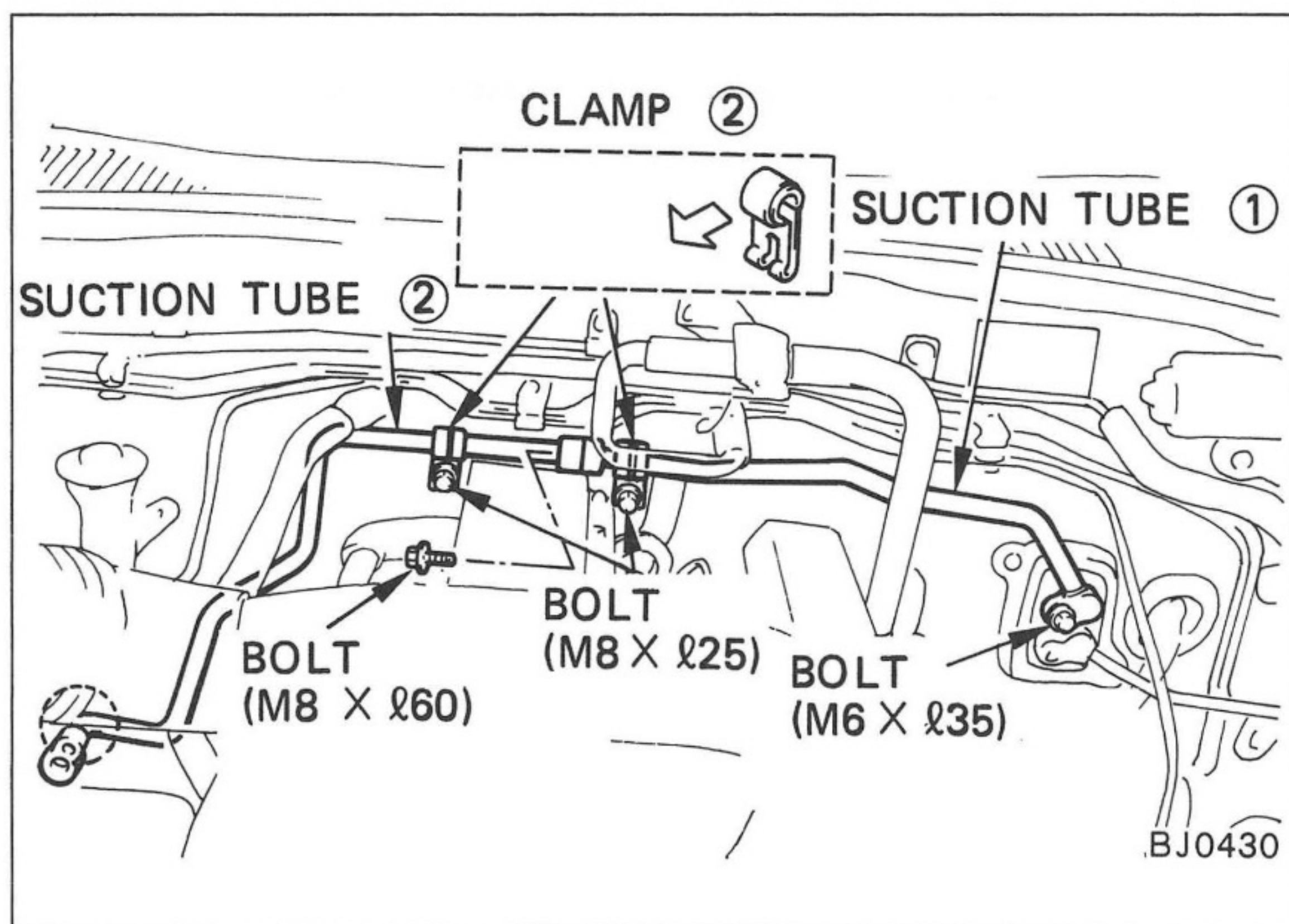

Fig.55

- (e) Loosely install two clamp ② to the suction tube ① and ②.
- (f) Connect the suction tube ① to the cooling unit using a bolt.
- Tightening Torque:  
55 kg-cm (5.0 N-m, 4.0 ft-lbs)

- (g) Connect the suction tube ① to the suction tube ② using a bolt.
- Tightening Torque:  
130 kg-cm (12 N-m, 9 ft-lbs)

- (h) Fasten the suction tube ① and ② using two clamp ② and two bolts loosely installed.

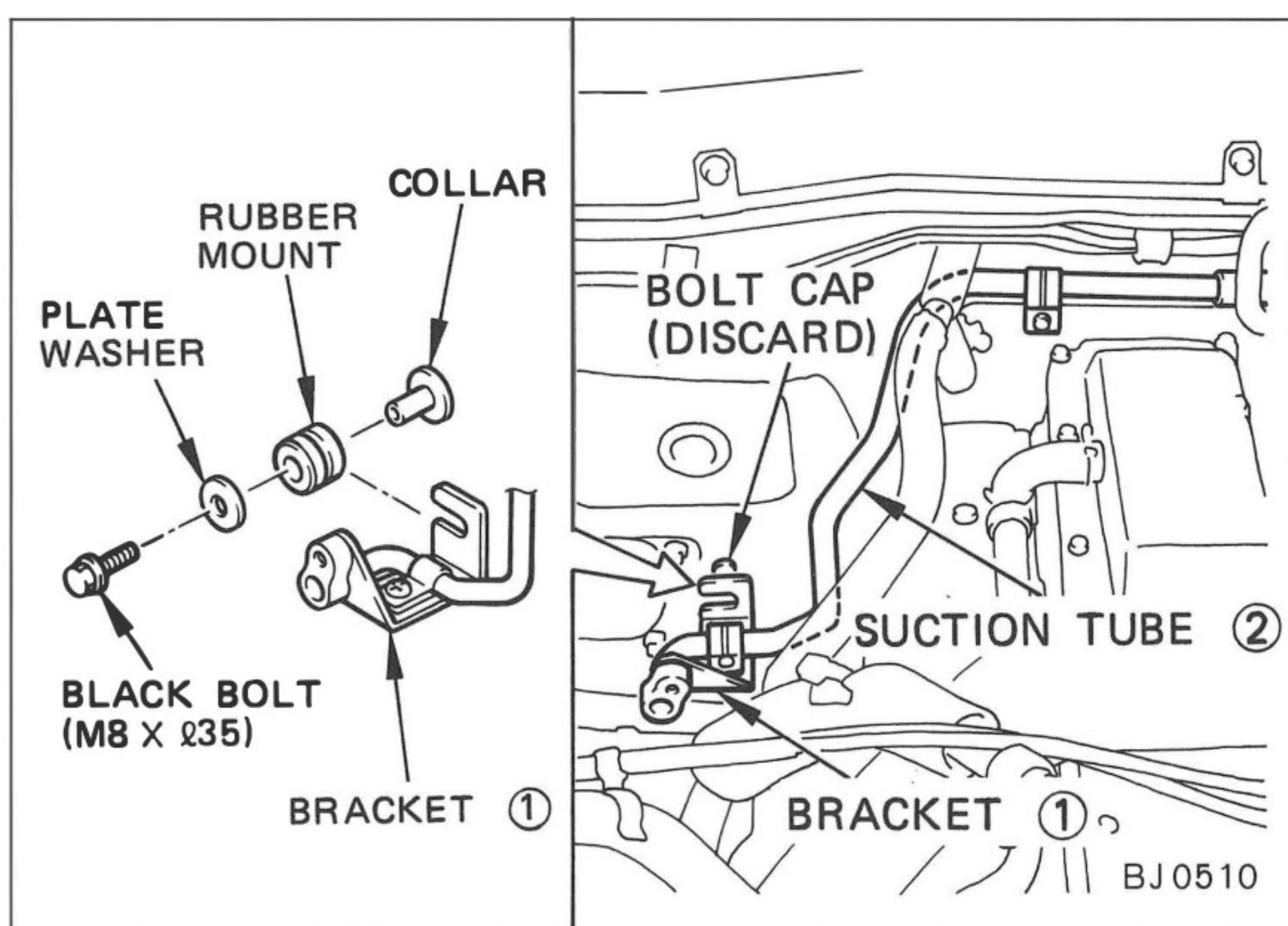

Fig.56

- (i) Assemble the rubber mount and collar to the bracket ① and fasten the suction tube ② in place of the bolt on to the bulkhead using a plate washer and a bolt.

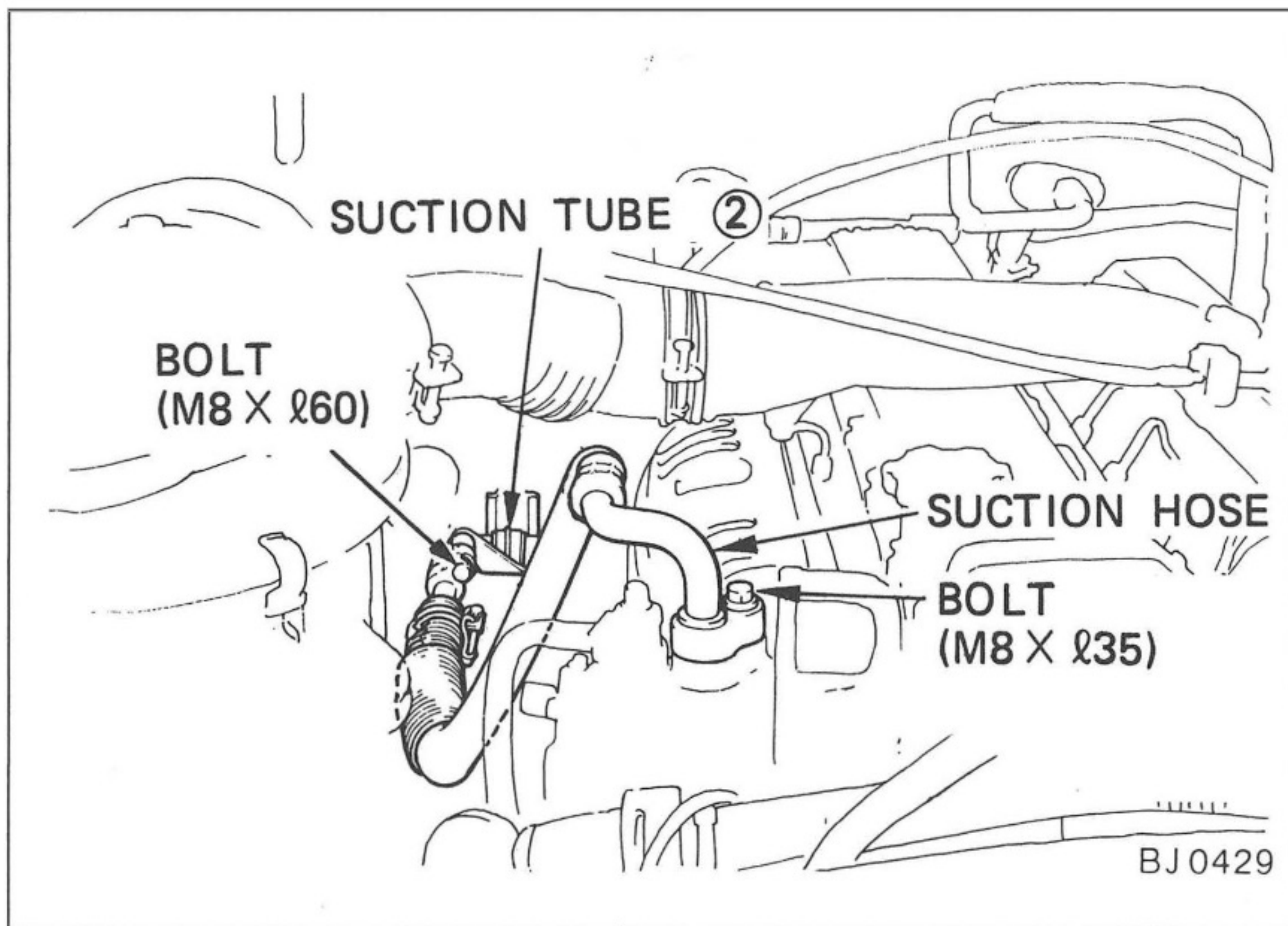

Fig.57

**(9) SUCTION HOSE**

- (a) Connect the suction hose from the compressor to the suction tube ② using a bolt.

Tightening Torque: Compressor side  
250 kg-cm (24 N-m, 18 ft-lbs)

Tightening Torque: Suction tube ②  
185 kg-cm (18 N-m, 13 ft-lbs)

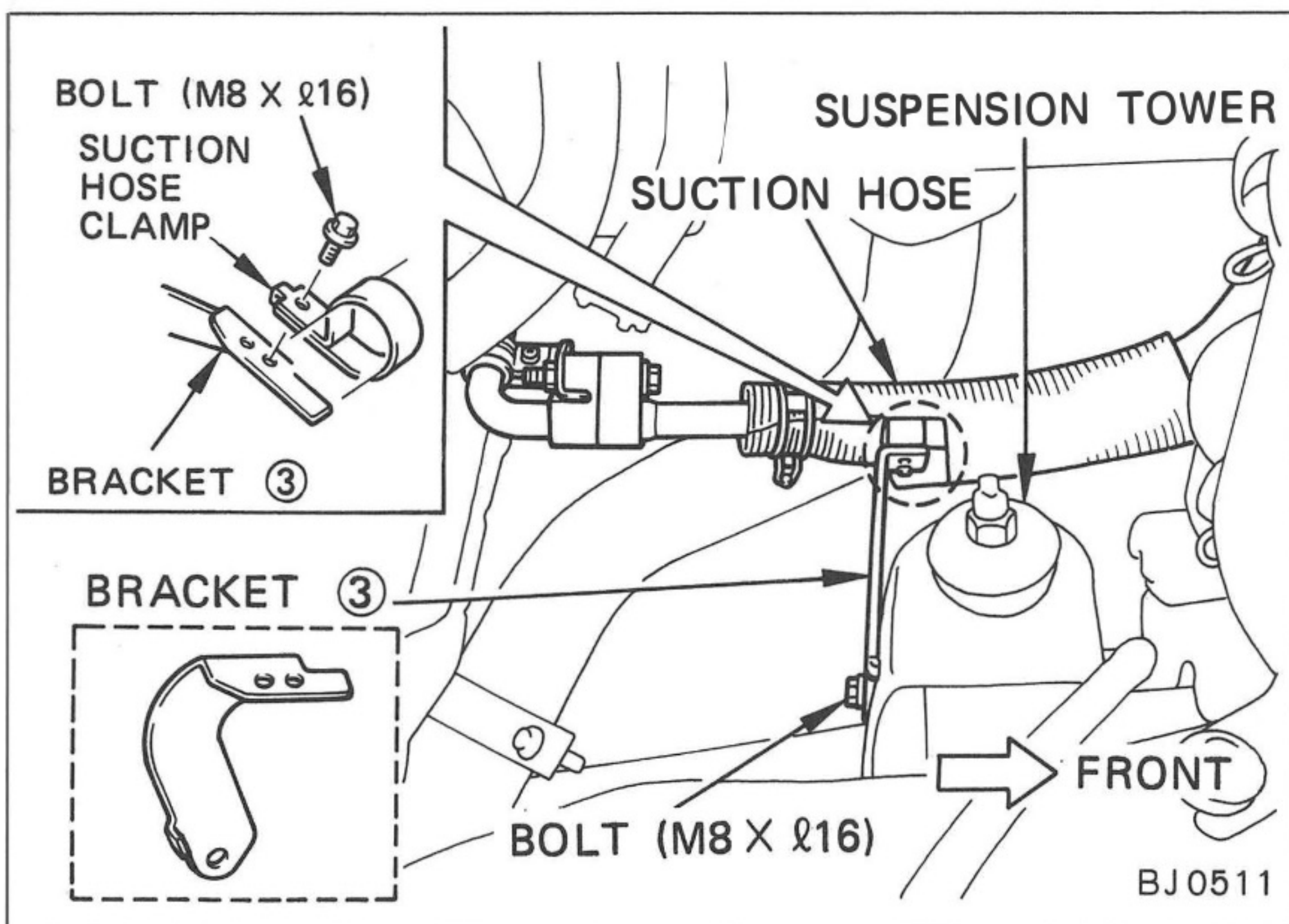

Fig.58

- (b) Install the bracket ③ to the suction hose clamp using a bolt.
- (c) Install the bracket ③ to the suspension tower using a bolt.

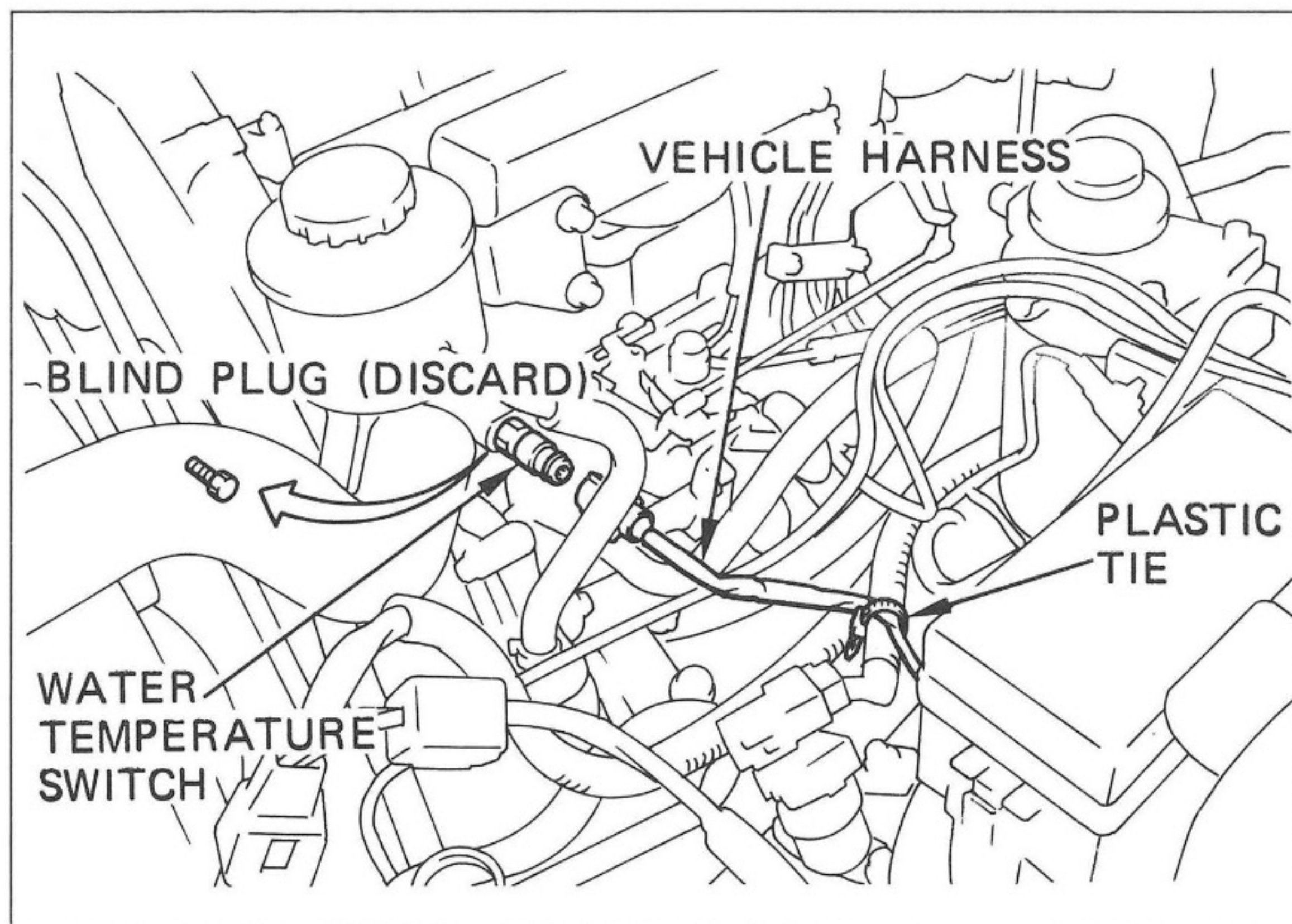

Fig.59

## (10) WATER TEMPERATURE SWITCH

- 1HZ ENGINE MODEL  
1HD-T ENGINE & A/T MODEL

- (a) Loosen the water filler cap to release the pressure.

### CAUTION

*Never open the water filler cap when hot.*

- (b) Close the water filler cap.
- (c) Remove and discard the blind cap.
- (d) Install the water temperature switch supplied in the kit.

Tightening Torque :

350 kg-cm (34 N-m, 25 ft-lbs)

- (e) Connect the vehicle harness to the water temperature switch.
- (f) Secure the vehicle harness to the battery cable using a plastic tie as shown.

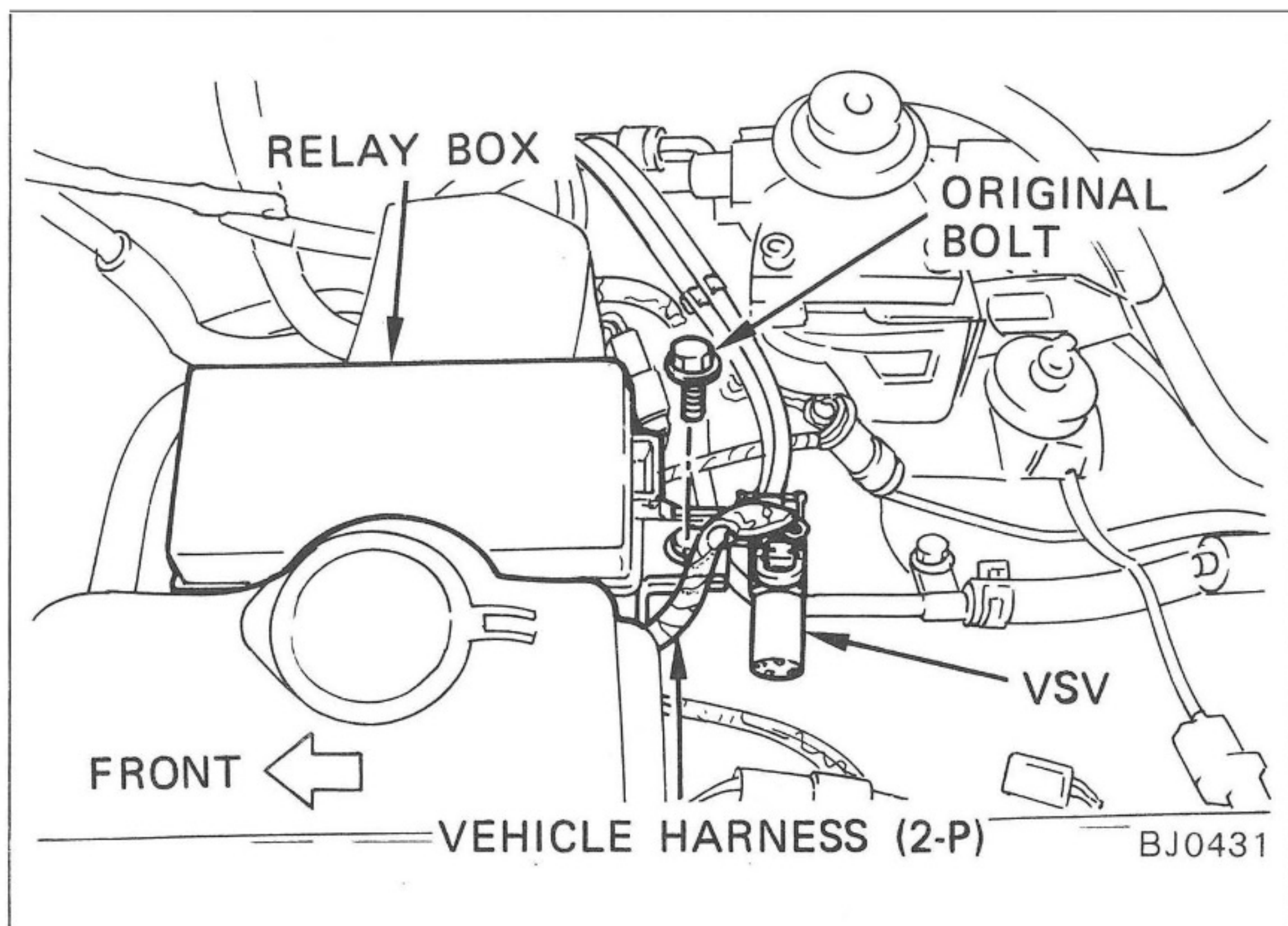

Fig.60

## (11) ENGINE IDLE SPEED CONTROL

- (a) Install the VSV together with the relay box using a original bolt.
- (b) Connect the vehicle harness to the VSV.

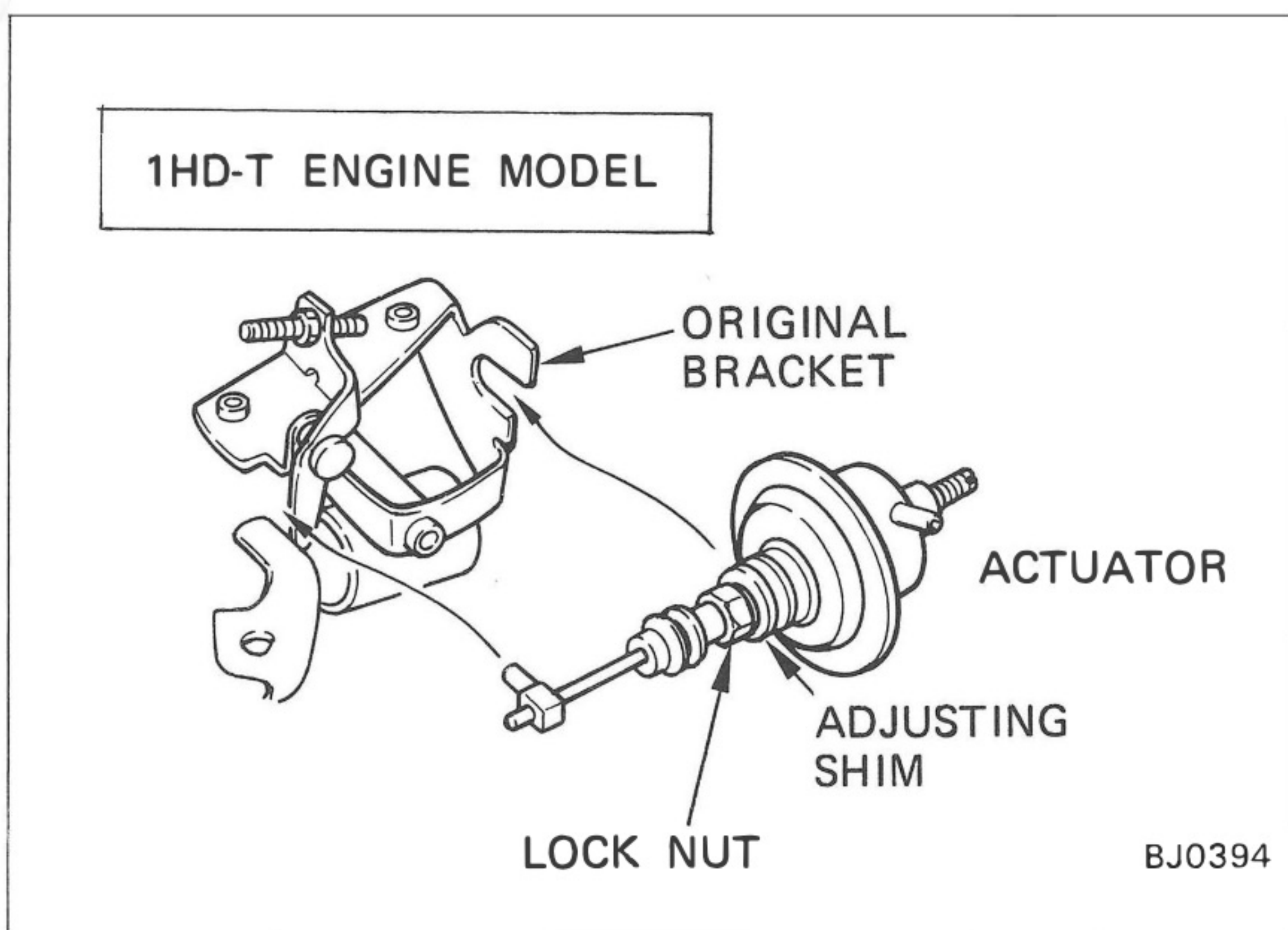

Fig.61

### (c) ■ 1HD-T ENGINE MODEL

Install the actuator to the original bracket on the injection pump.

Tightening Torque: Lock nut  
95 kg-cm ( 9 N-m, 7 ft-lbs)

#### NOTE

*Position the adjusting shims so that the arm of the actuator is as close as possible to the throttle lever but without touching the throttle lever.*

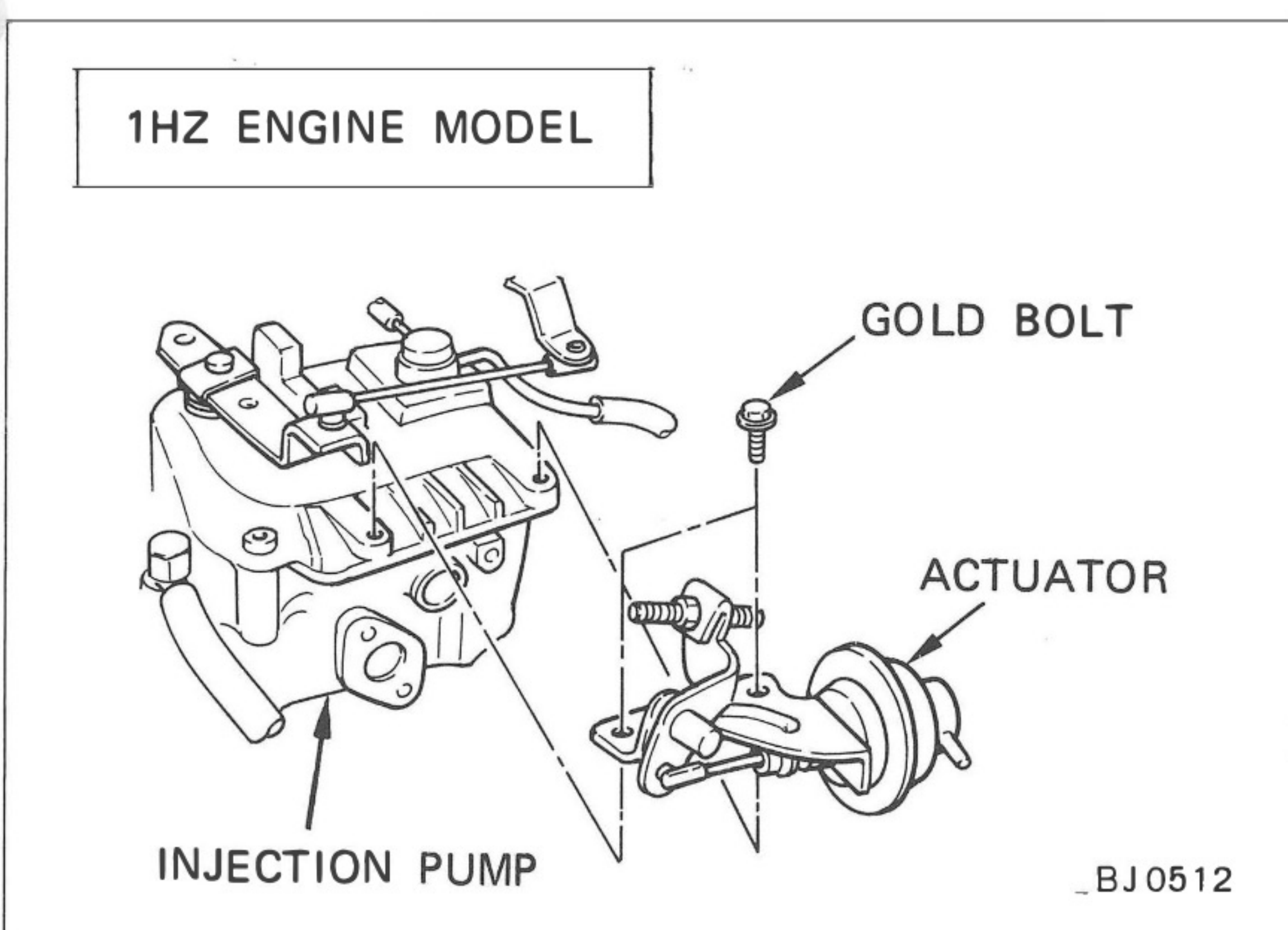

Fig.62

### (d) ■ 1HZ ENGINE MODEL

Install the actuator to injection pump using two bolts.

Tightening Torque: Lock nut  
80 kg-cm ( 8 N-m, 6 ft-lbs)

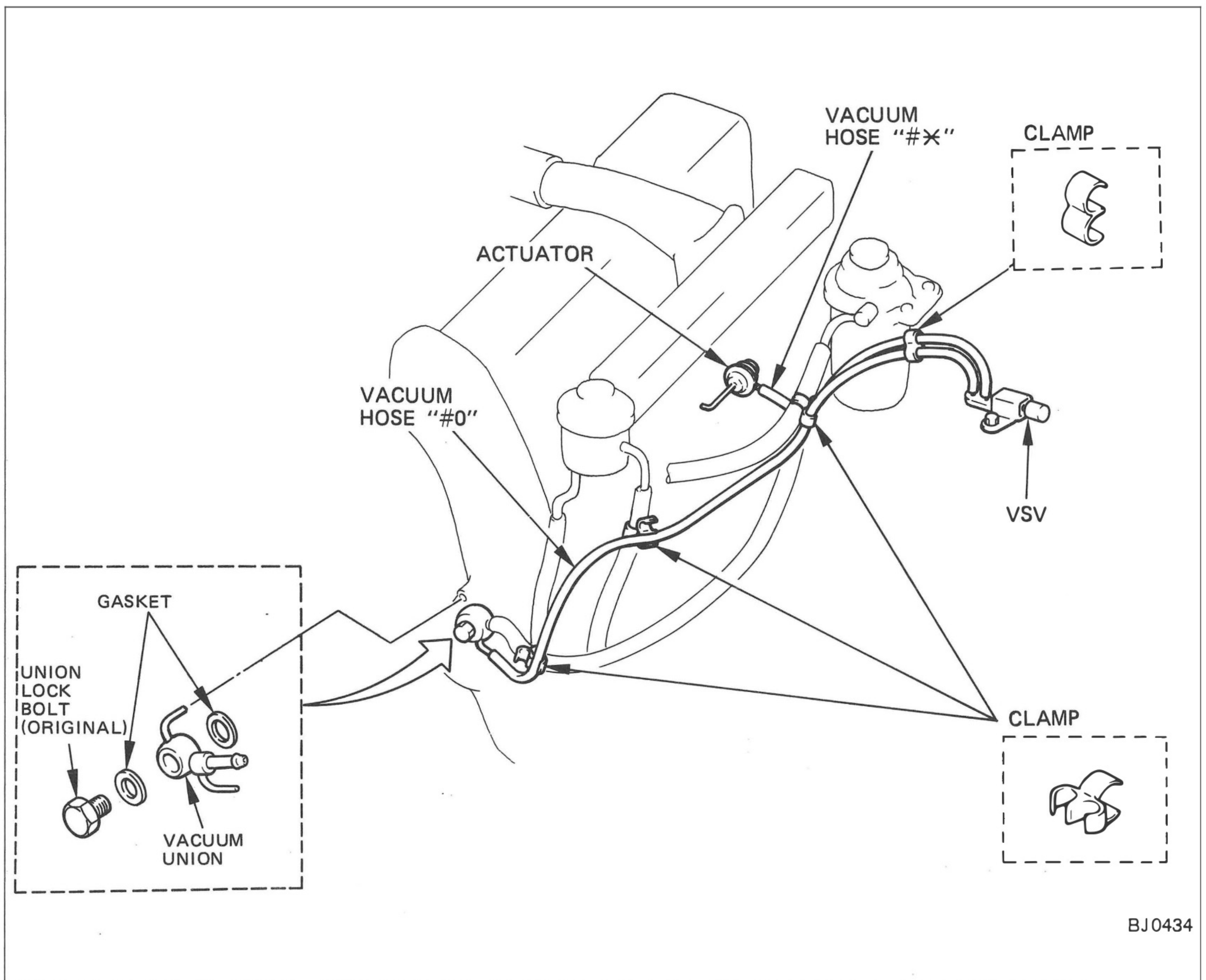

Fig.63

- (e) Exchange the vacuum union and two gaskets to the new one supplied in the kit.

Tightening Torque: Lock bolt  
 140 kg-cm (14 N-m, 10 ft-lbs)

- (f) Connect the vacuum hose“#\*” to the actuator and vacuum hose“#0” to the vacuum union.
- (g) Secure the vacuum hoses using four clamps as shown.

## (12) BATTERY CARRIER

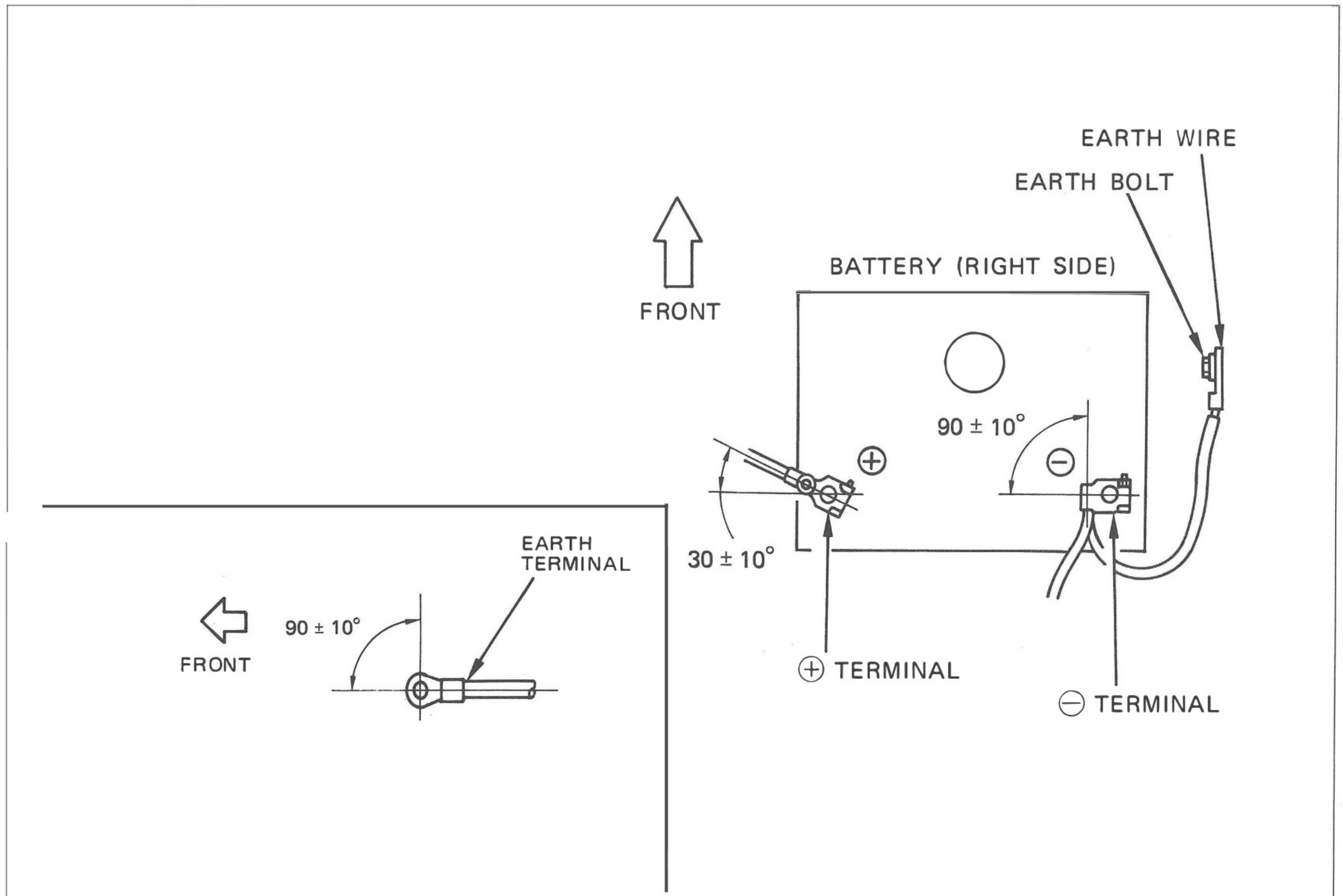

Fig.64

- (a) Reinstall the battery and the carrier.

**NOTE**

*Make sure the installation side of the battery terminals.*

- (b) Reinstall the earth terminal as shown.

### 1.3 INSTALLATION : ENGINE COMPARTMENT

#### ■ 3F, 3F-E ENGINE MODEL

\* Before making any hoses and tubes connections, apply a few drops of refrigerant oil to the seal of O-ring and coupling nuts.

\* When tightening and loosening fittings, use two wrenches for support.

#### Standard Torque for O-ring Fittings

Size of Tube (inch)	Fitting Torque kg-cm < N-m > (ft-lbs)
0.31	140 < 13.7 > (10.1)
0.50	230 < 22.5 > (16.6)
0.62	330 < 32.3 > (23.8)

Bolted type fittings	Fitting Torque kg-cm < N-m > (ft-lbs)
Compressor Side	250 < 24 > ( 18 )
Condenser side	185 < 18 > ( 13 )
Receiver side	55 < 5.4 > ( 4.0)
Cooling unit side	55 < 5.4 > ( 4.0)
Suction tube side	130 < 13 > ( 9 )

■ PIPING LAYOUT

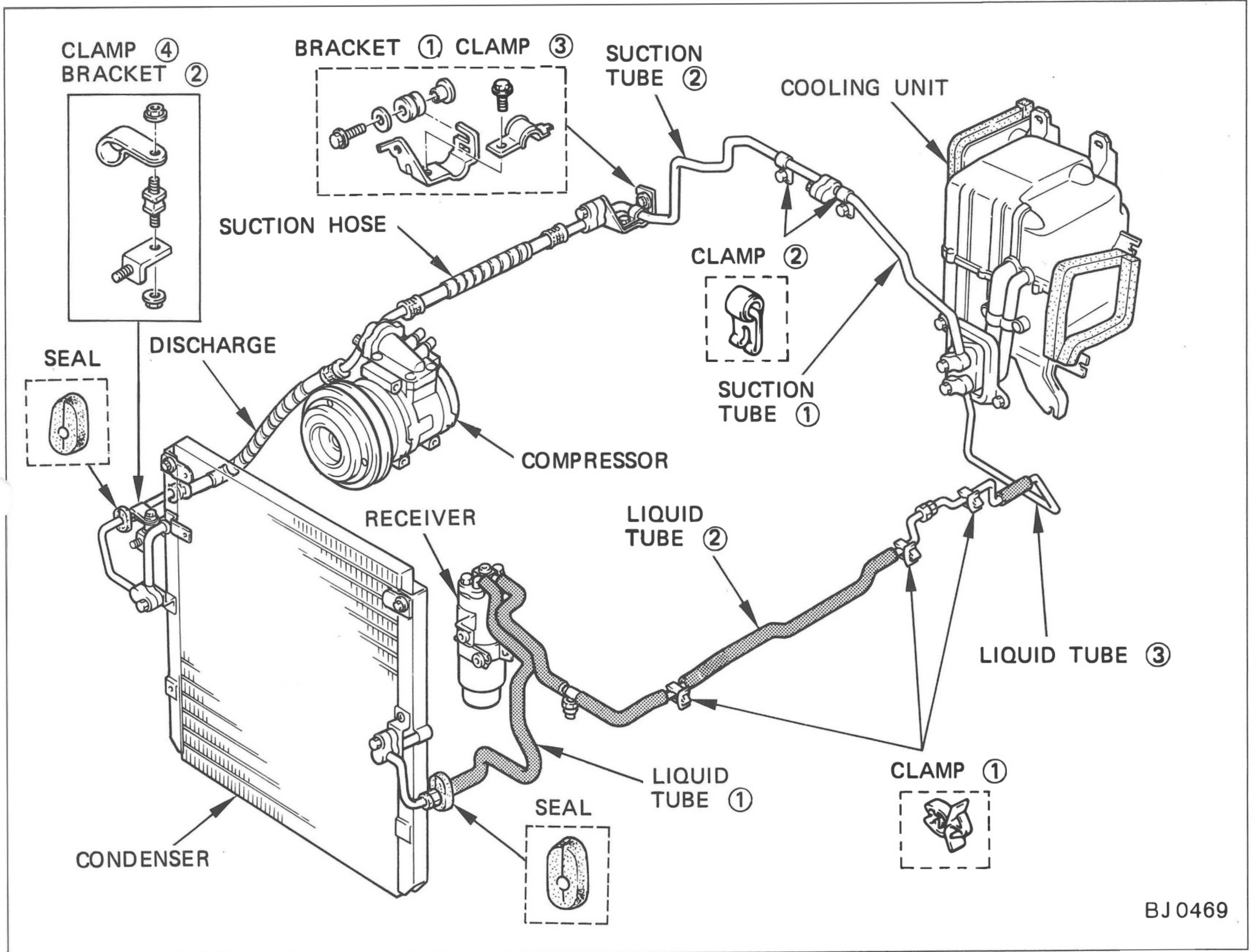

Fig.65

**(1) REMOVAL OF PARTS**

Remove the following parts

- (a) Radiator reserve tank
- (b) Battery

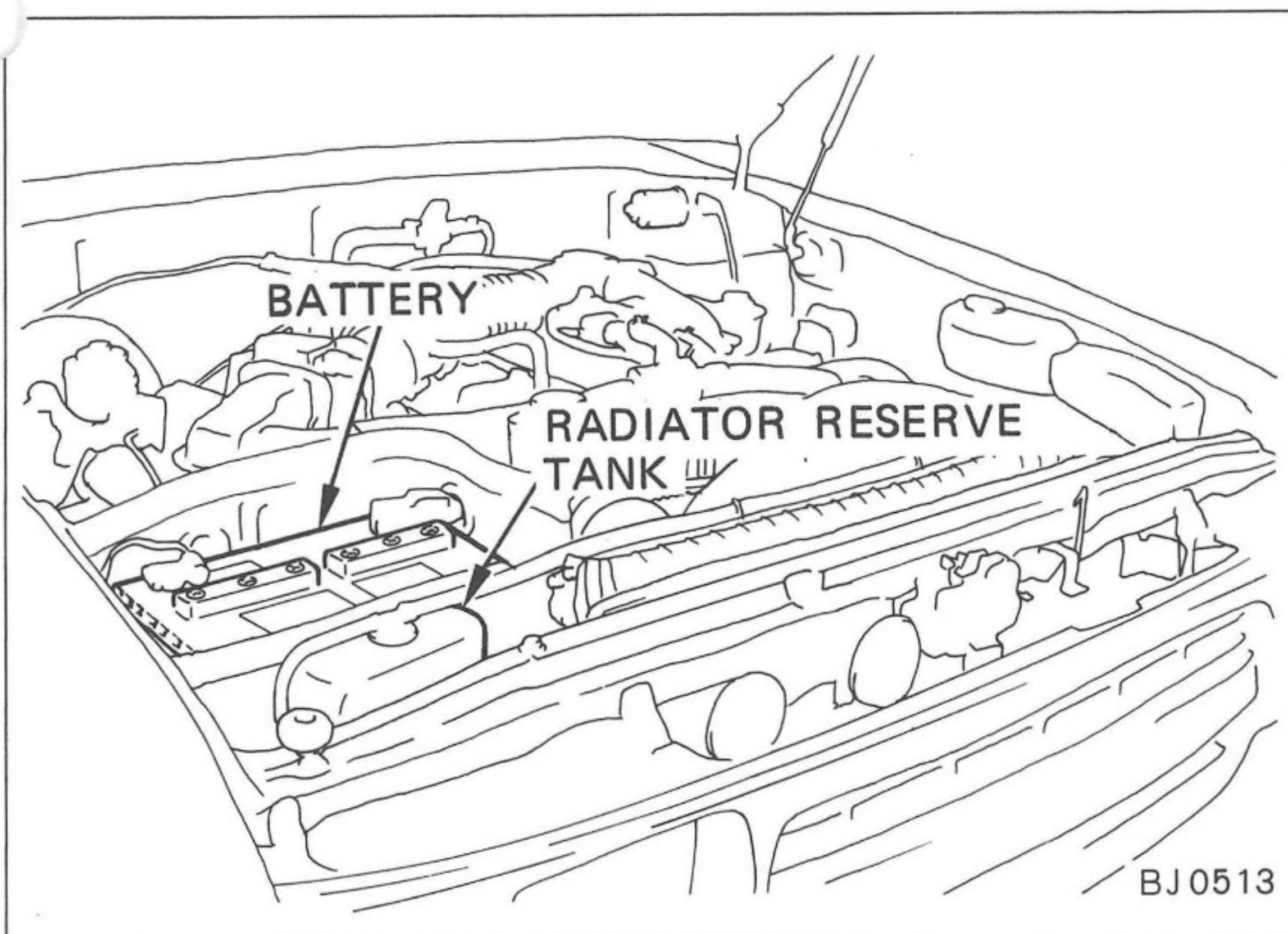

Fig.66

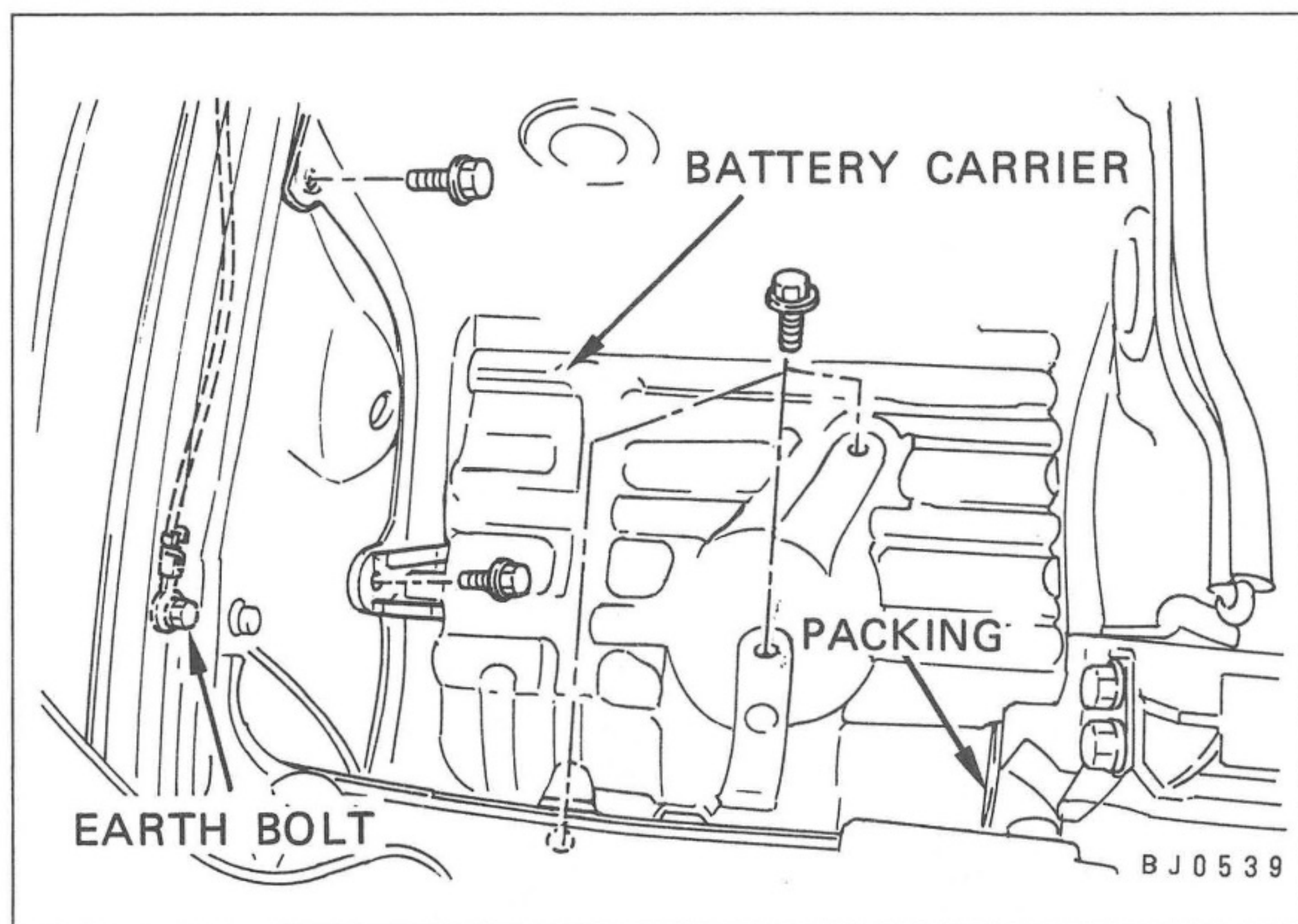

Fig.67

(c) Earth bolt, Battery and Packing

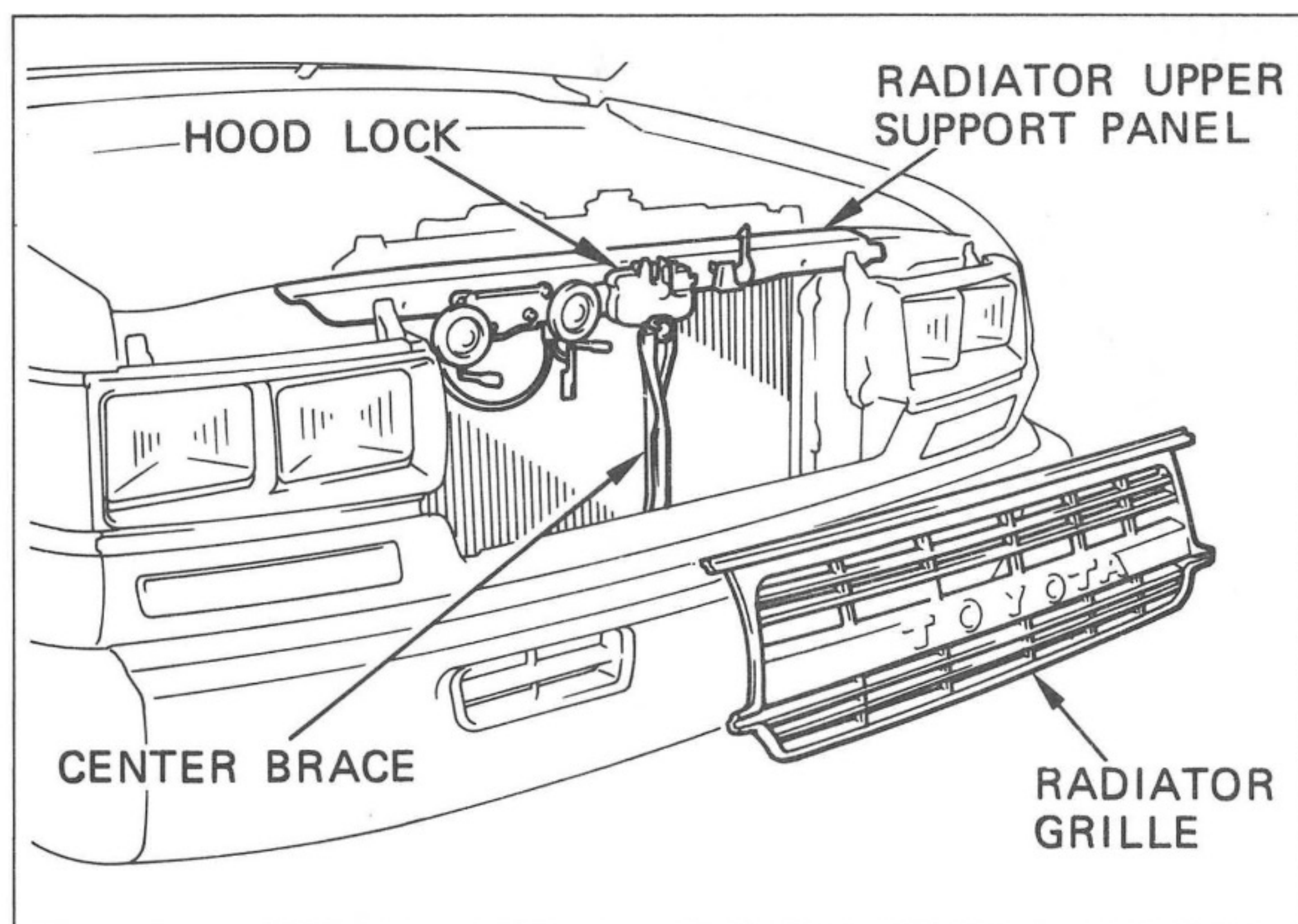

Fig.68

- (d) Radiator grille
- (e) Hood lock and centre brace
- (f) Radiator upper support panel

**NOTE**

- 1) Disconnect the horn harness.
- 2) Unclip the vehicle harness from the radiator upper support panel.

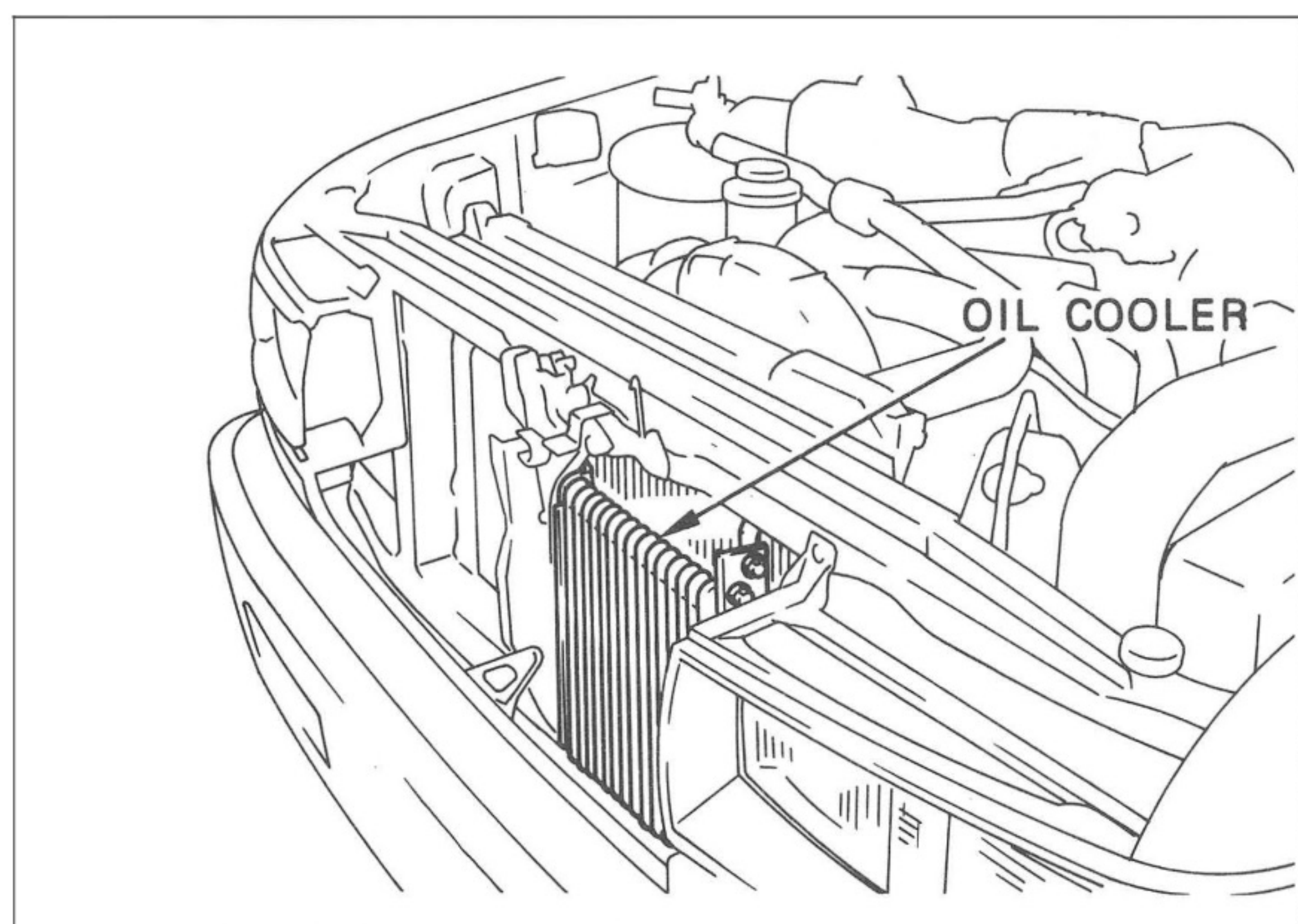

Fig.69

(g) Oil cooler (Equipped model only)

**CAUTION**

*Don't disconnect the oil cooler hose.*

**NOTE**

*Remove only the mounting bolts for the oil cooler, which are located, two on the centre brace and one on the radiator support panel.*

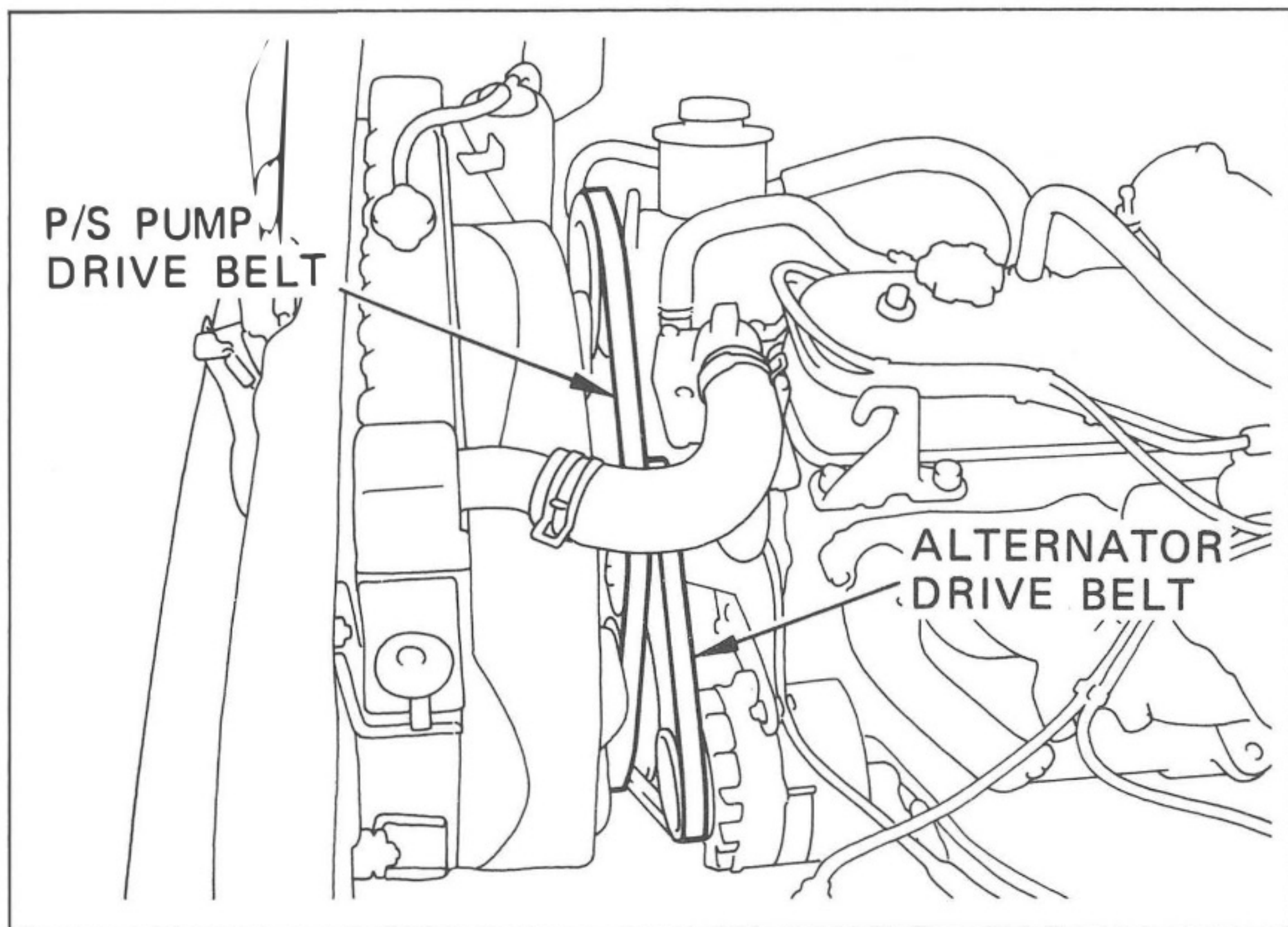

Fig.70

■ 3F-C ENGINES ONLY

- (h) Alternator drive belt.
- (i) P/S drive belts.

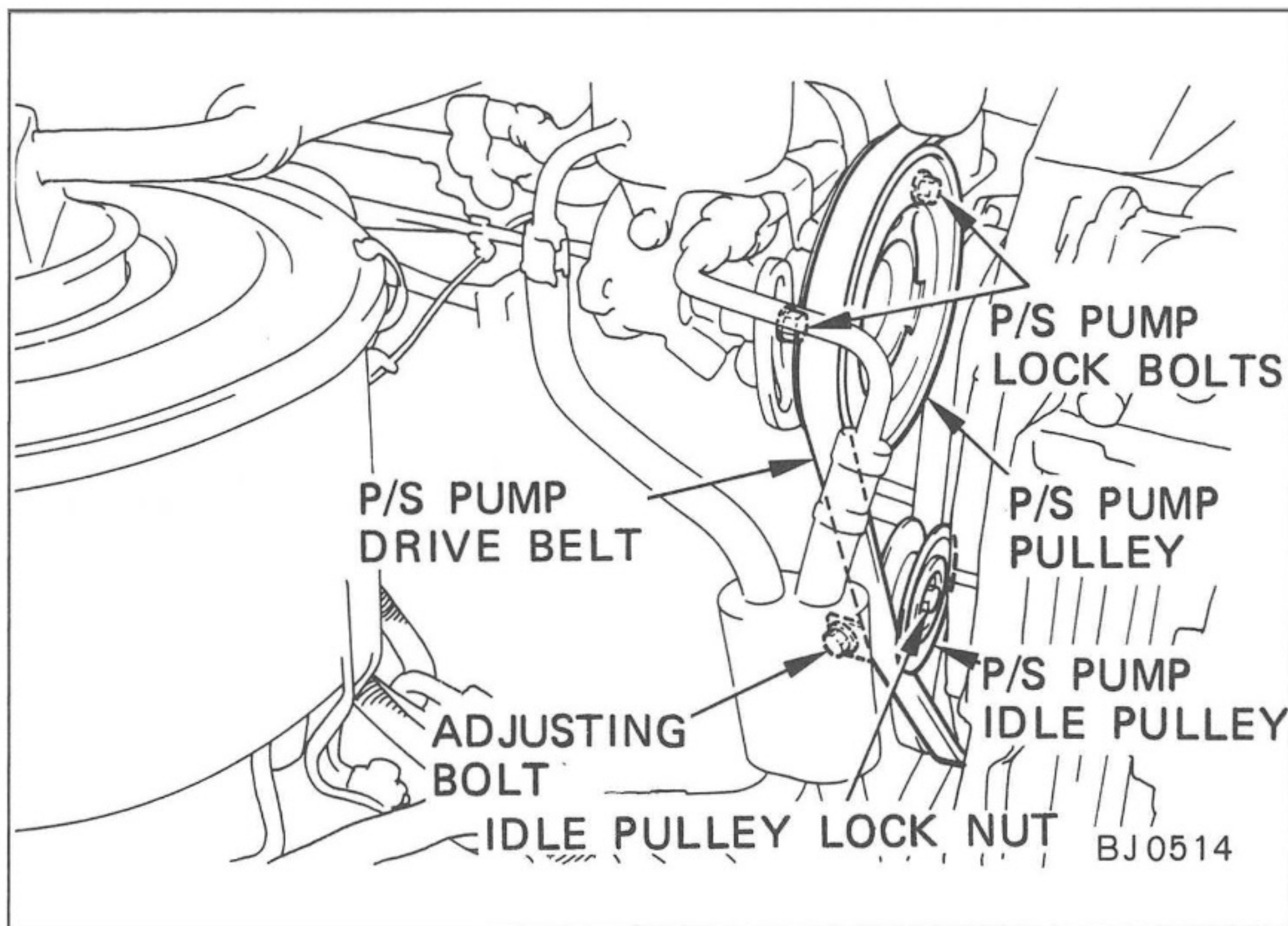

Fig.71

■ 3F-E ENGINES ONLY

- (j) P/S pump drive belt

**NOTE**

1. Loosen the idle pulley lock nut and adjusting bolt, then remove P/S pump drive belt.
2. If couldn't remove the drive belt, loosen the P/S pump lock bolts, then remove P/S pump drive belt.

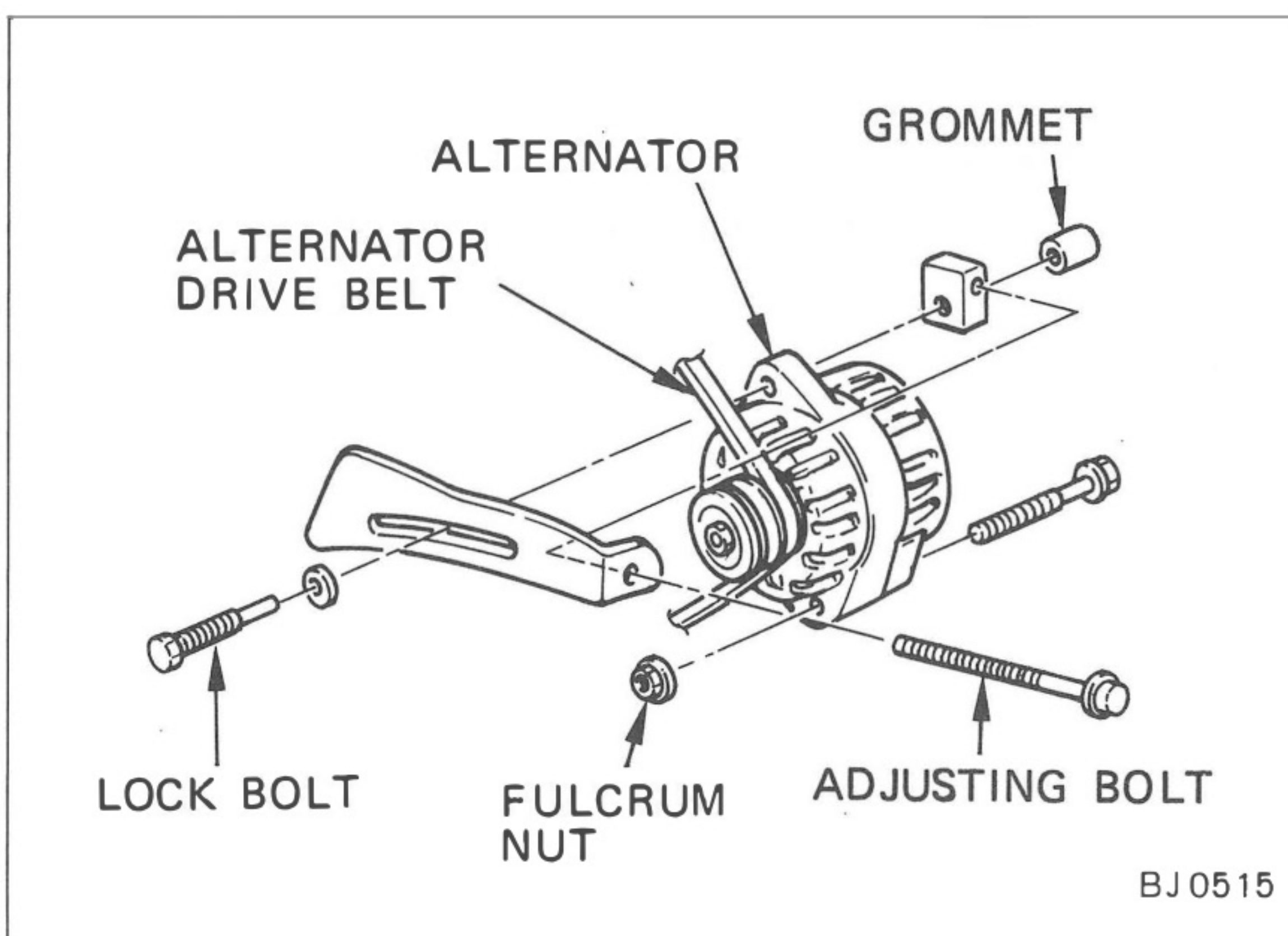

Fig.72

- (k) Alternator drive belt

**NOTE**

Loosen the fulcrum nut, lock bolt and the adjusting bolt, then remove the alternator drive belt.

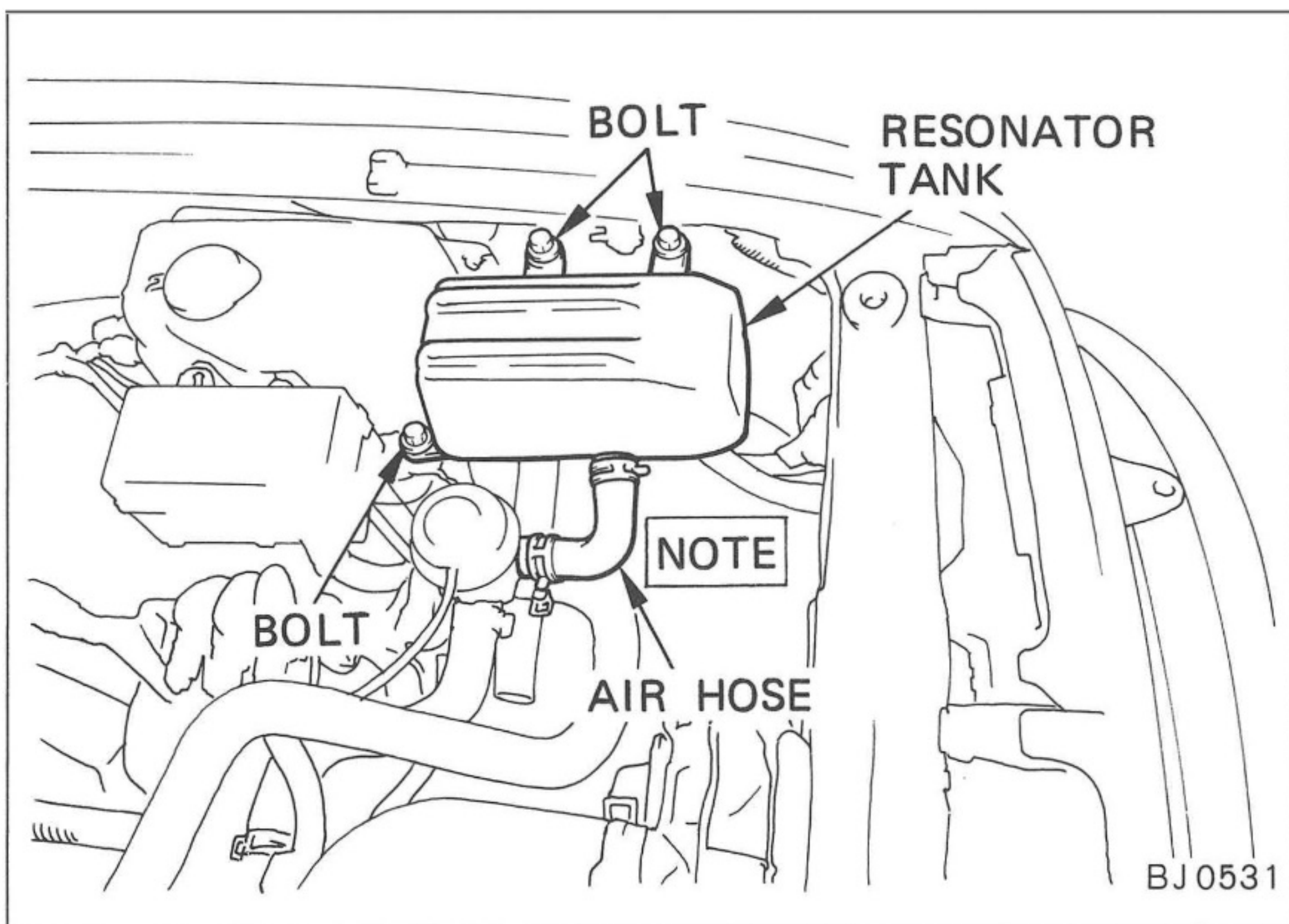

Fig.73

(l) Resonator tank & air hose

**NOTE**

*Blower assy (if fitted).*

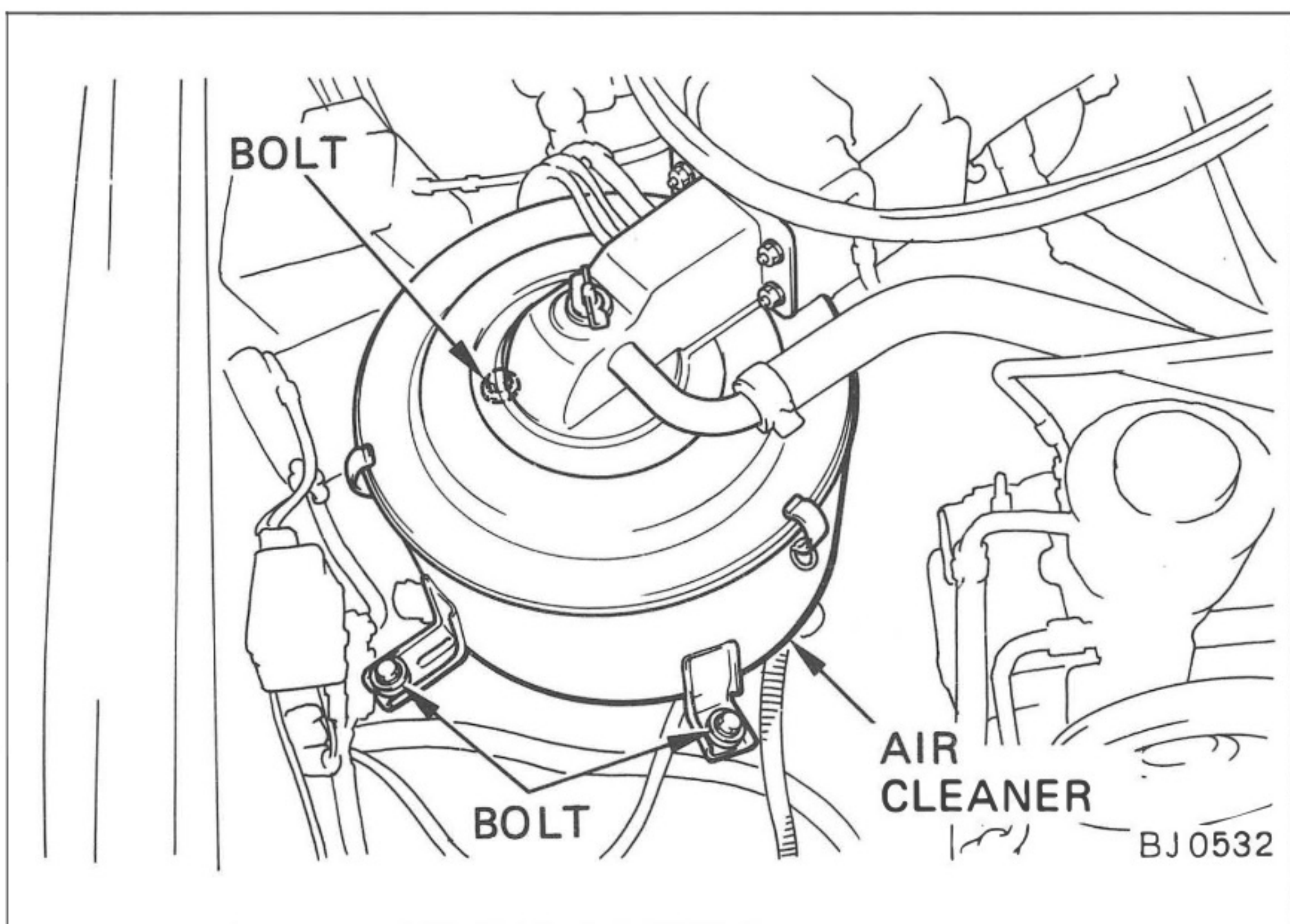

Fig.74

(m) Air cleaner assembly.

**NOTE**

*3F-C engine has a similar air cleaner.*

**IMPORTANT**

*Please take note of where all the vacuum hoses are fitted.*

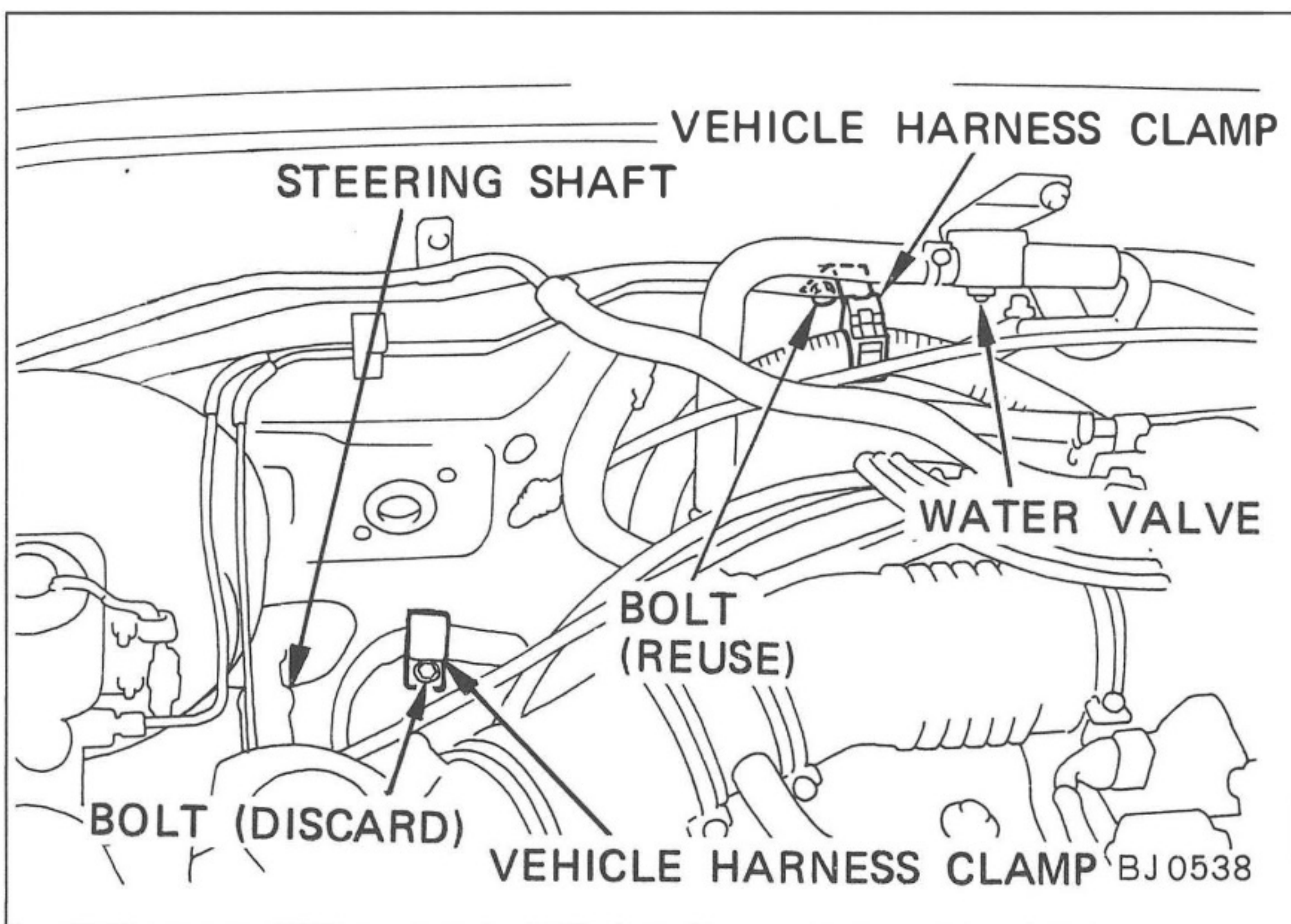

Fig.75

(n) Vehicle harness clamp & bolts

**NOTE**

*Discard a original bolt beside the steering shaft.*

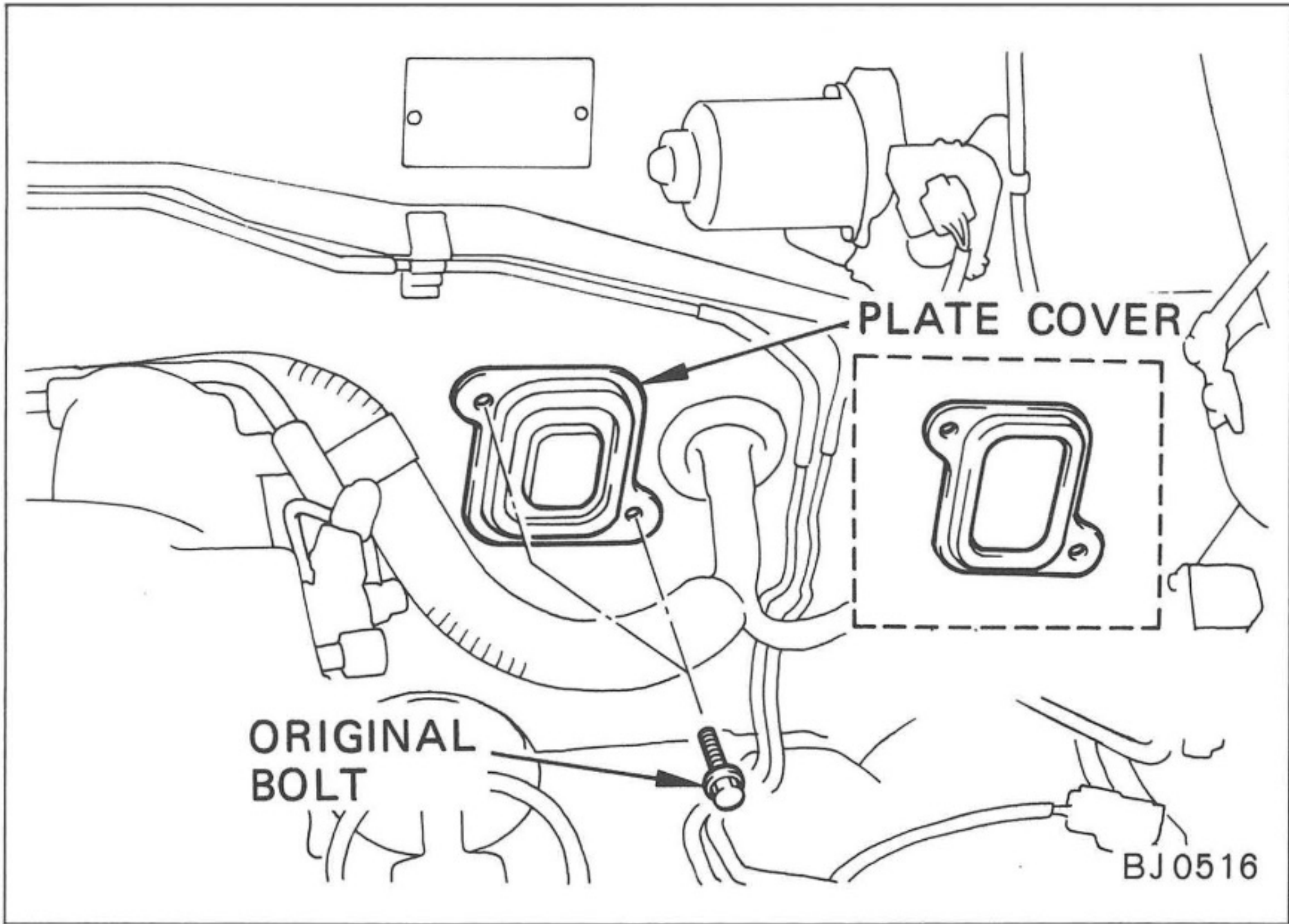
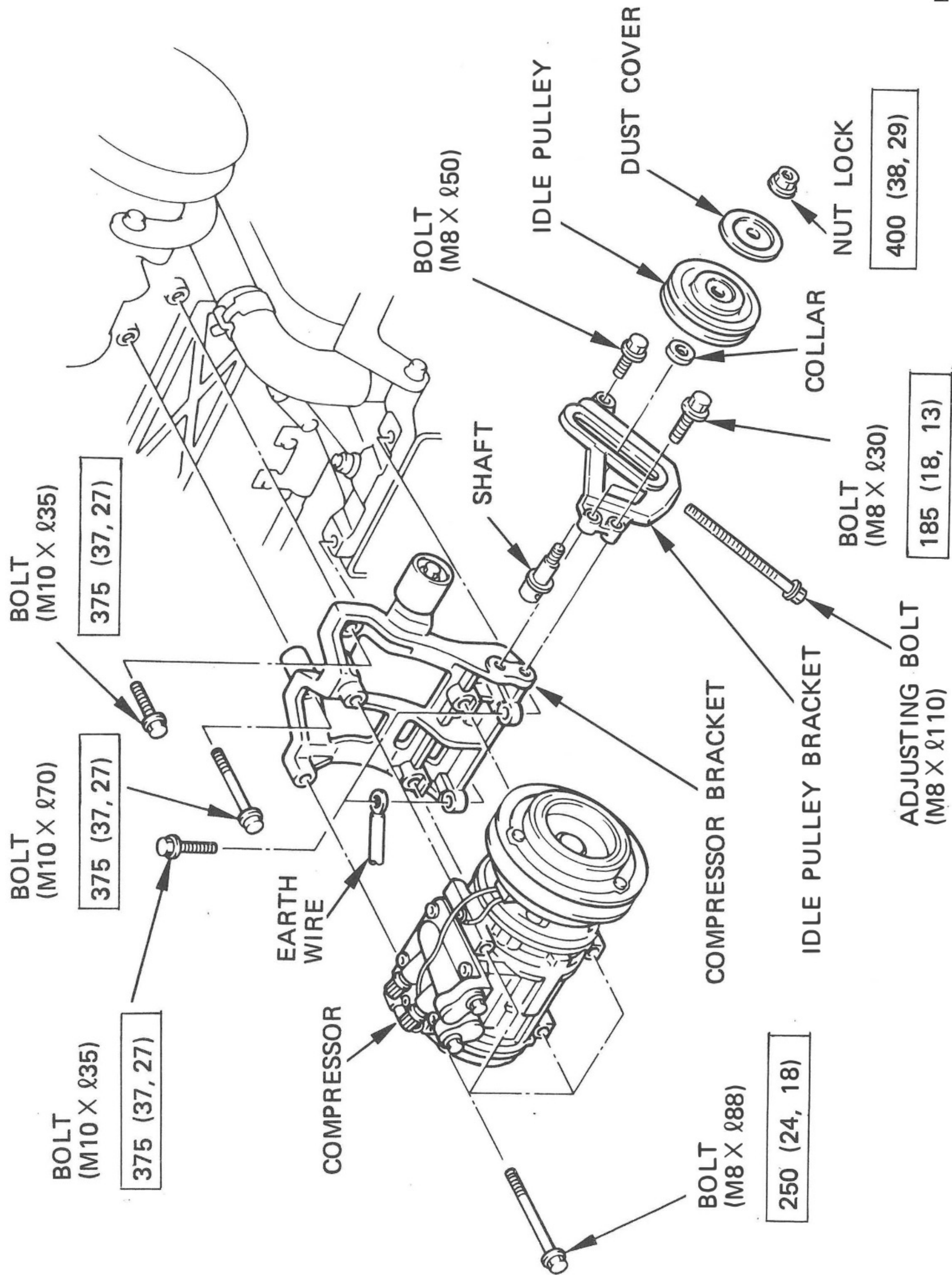

Fig.76

**(2) PLATE COVER**

- (a) Install the plate cover supplied in the kit on the bulkhead using two original bolts.

(3) COMPRESSOR



BJ0467

Fig.77

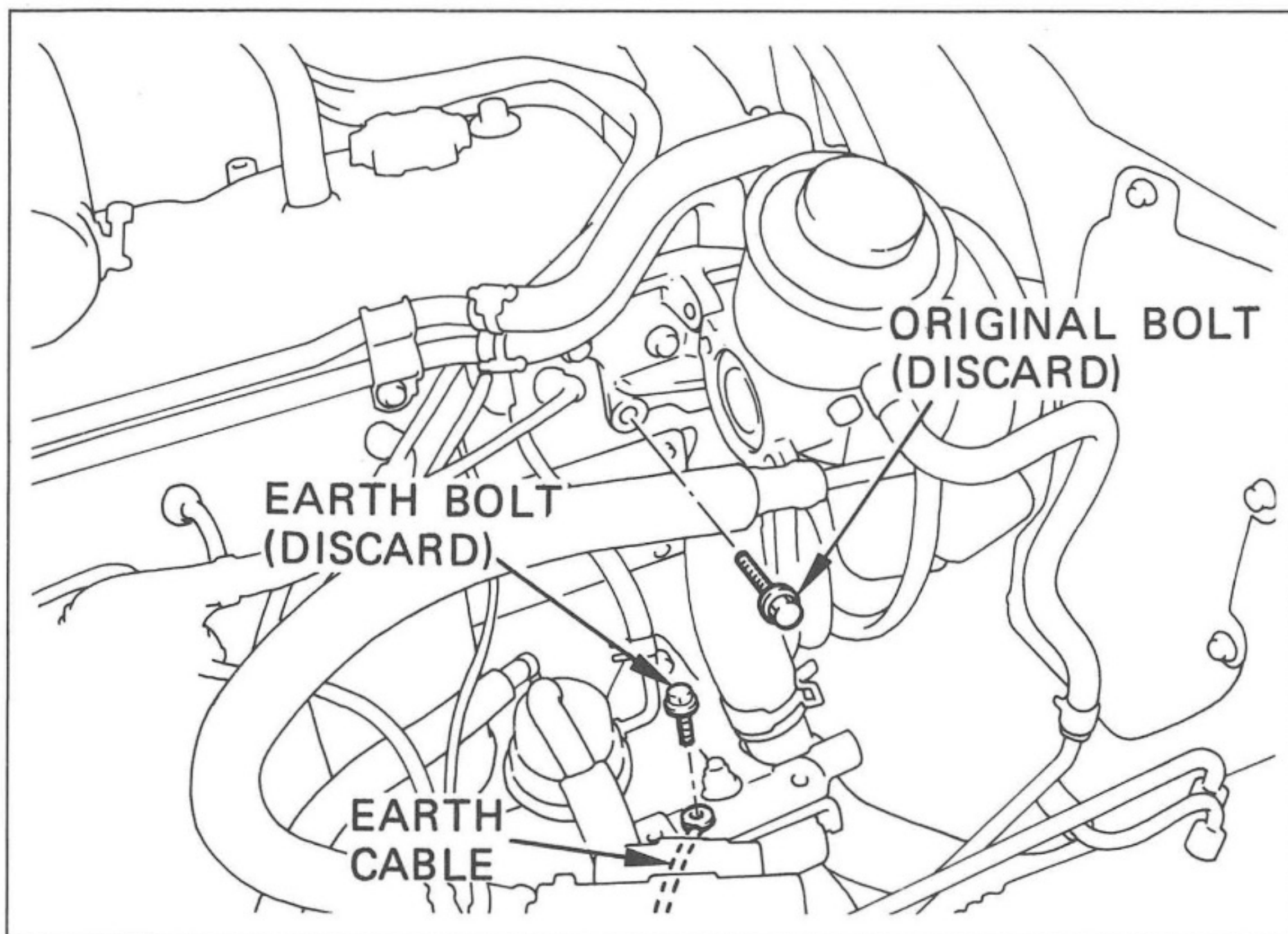

Fig.78

- (a) Remove and discard the original bolts from the engine block and one from the earth cable.

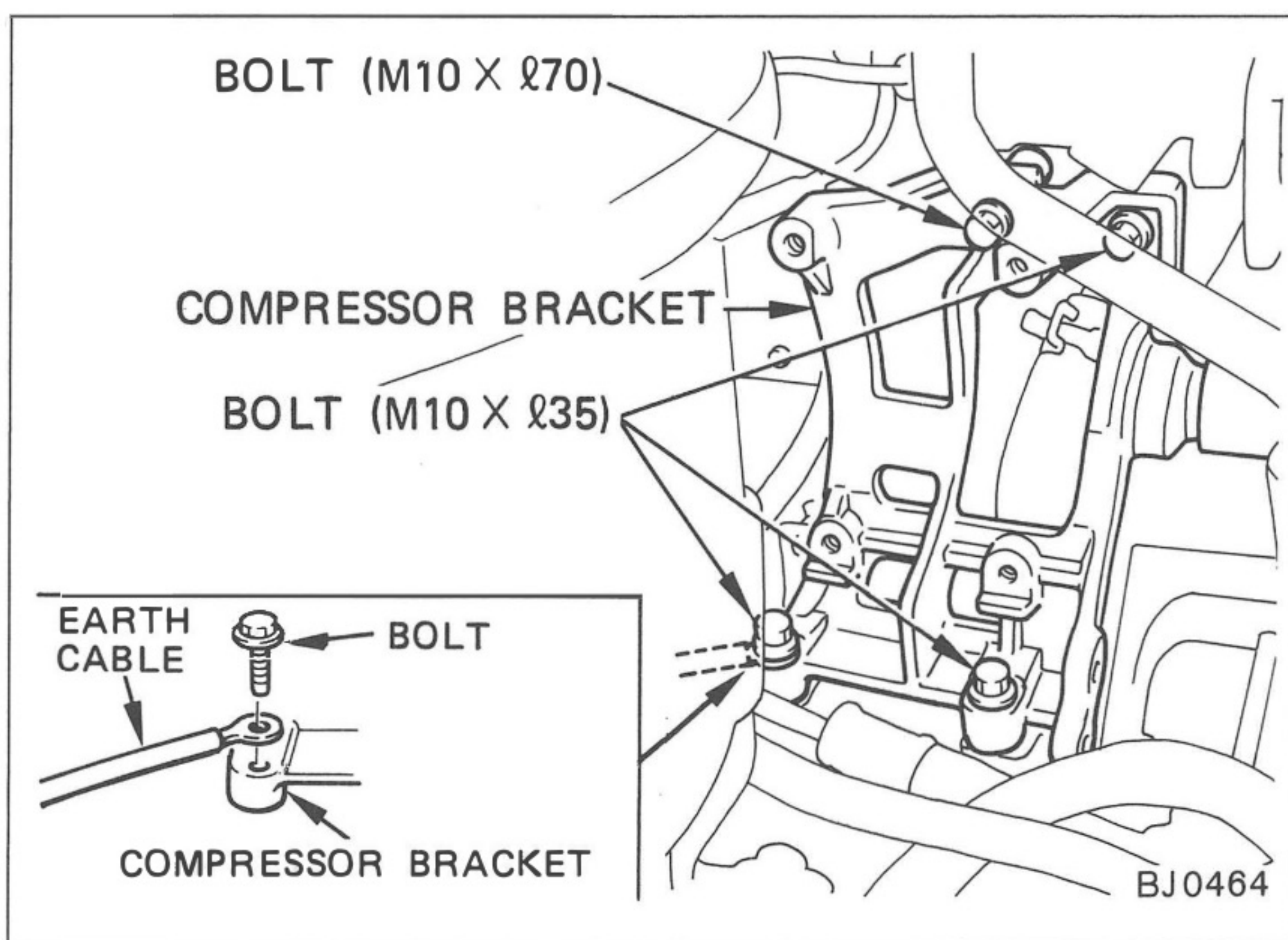

Fig.79

- (b) Install the compressor bracket to the engine block using four bolts.

**NOTE**

*Reinstall the earth cable together with compressor bracket as shown.*

Tightening Torque:  
375 kg-cm (37 N-m, 27 ft-lbs)

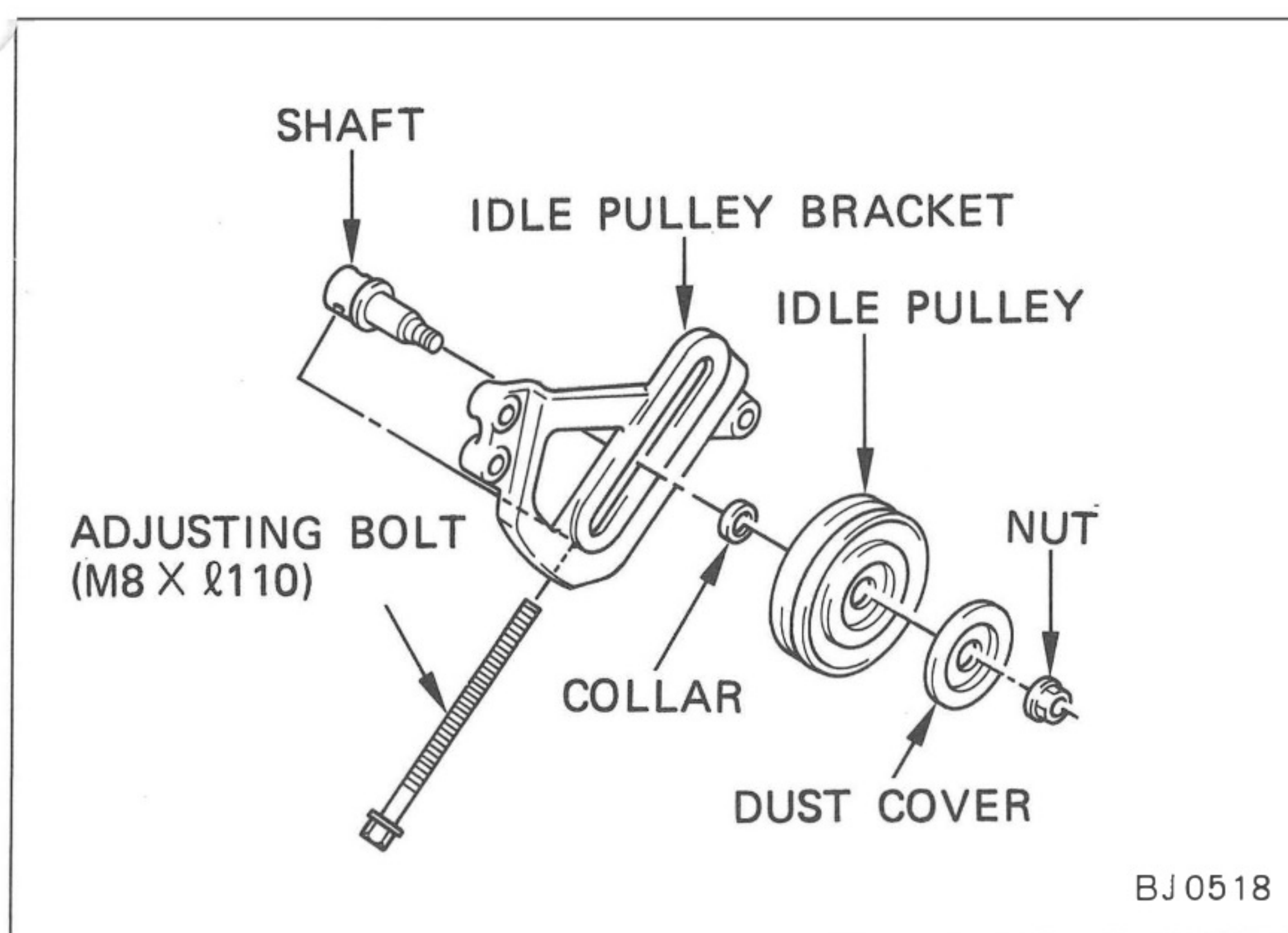

Fig.80

- (c) Assemble the idle pulley and adjusting bolt to the idle pulley bracket.

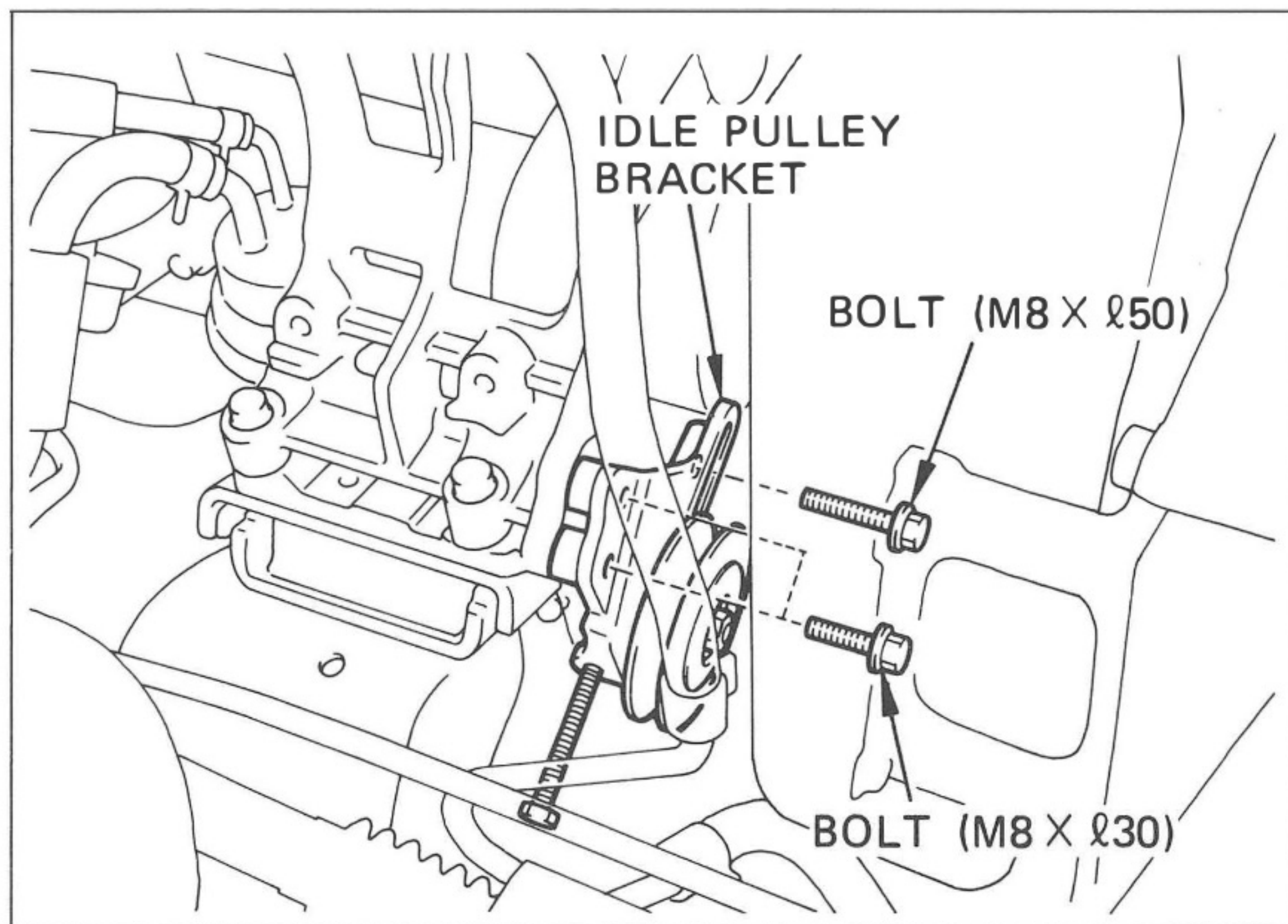

Fig.81

- (d) Install the idle pulley bracket with idle pulley to the compressor bracket using three bolts.

Tightening Torque:

185 kg-cm (18 N-m, 13 ft-lbs)

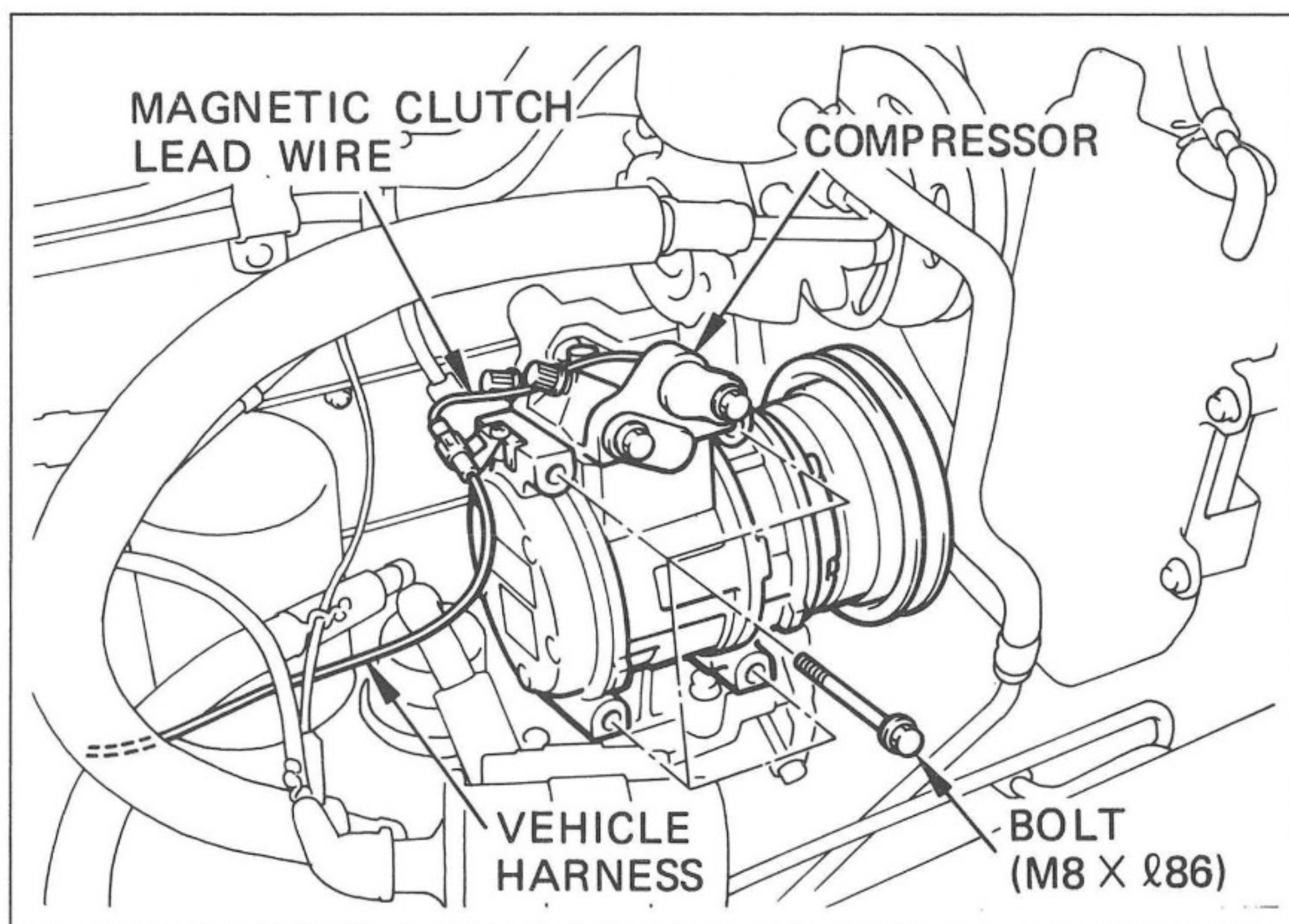

Fig.82

- (e) Install the compressor to the compressor bracket using four bolts.

Tightening Torque:

250 kg-cm (24 N-m, 18 ft-lbs)

- (f) Connect the vehicle harness to the magnetic clutch lead wire.

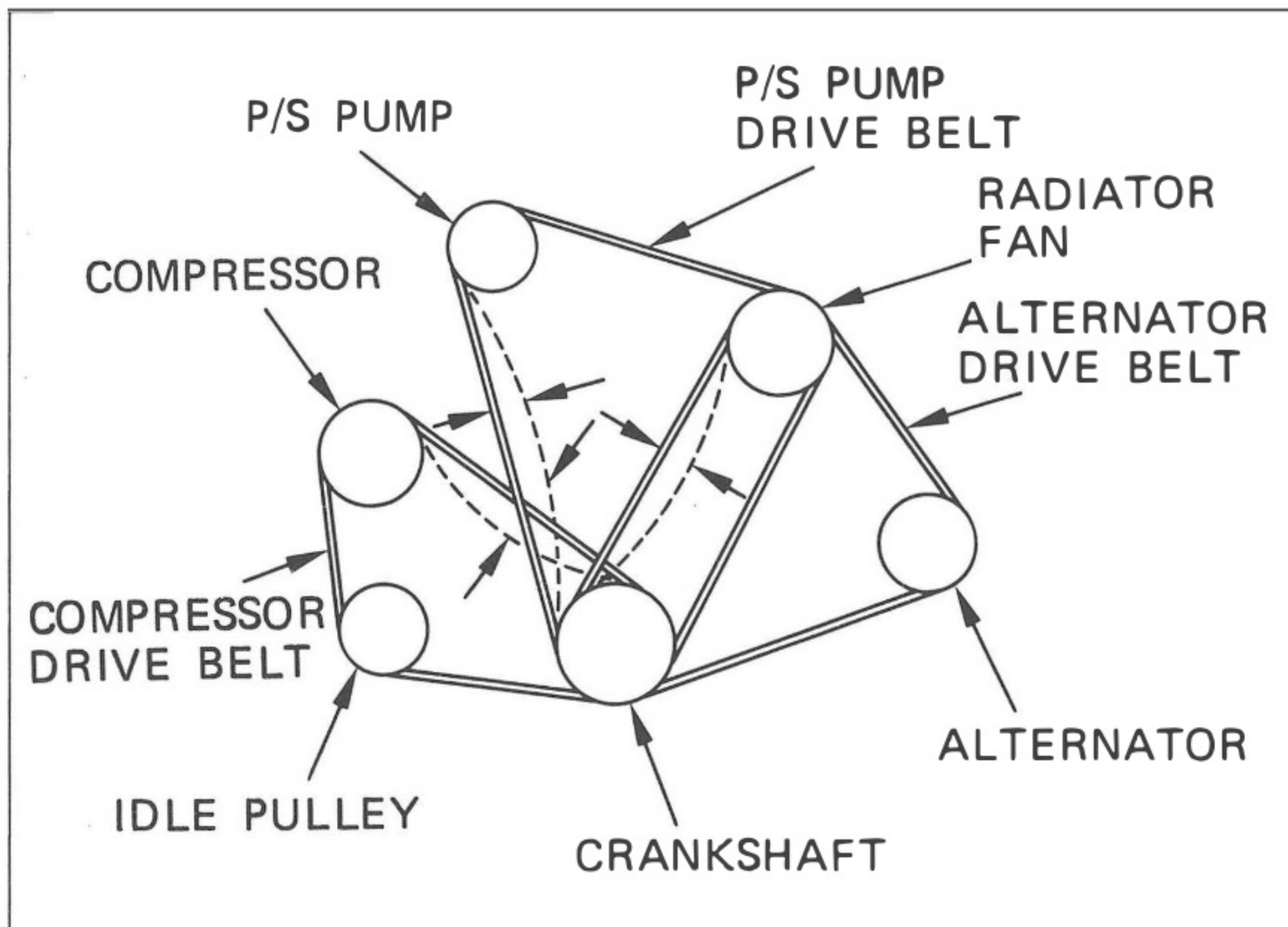

Fig.83

■ FOR 3F-C ENGINES ONLY

- (g) Install the compressor drive belt, alternator drive and P/S pump drive belt, then adjust the belt tension by turning the adjusting bolt (where fitted).
- (h) Check the belt deflection with an applied force as follows or check the belt tension using a Burroughs Drive Belt Tension Gauge (No. BT-33-73F) or a NIPPONDENSO BTG-20.

Drive belt & Applied force		Belt deflection
Alternator drive belt 8kg (17lbs)	Used belt	9 - 12 mm (0.35-0.47 inch)
Compressor drive belt 10kg (22lbs)	New belt	11 - 15 mm (0.43-0.59 inch)
	Used belt	15 - 21 mm (0.59-0.82 inch)
Spur drive belt 8kg (17lbs)	Used belt	8 - 10 mm (0.31-0.39 inch)

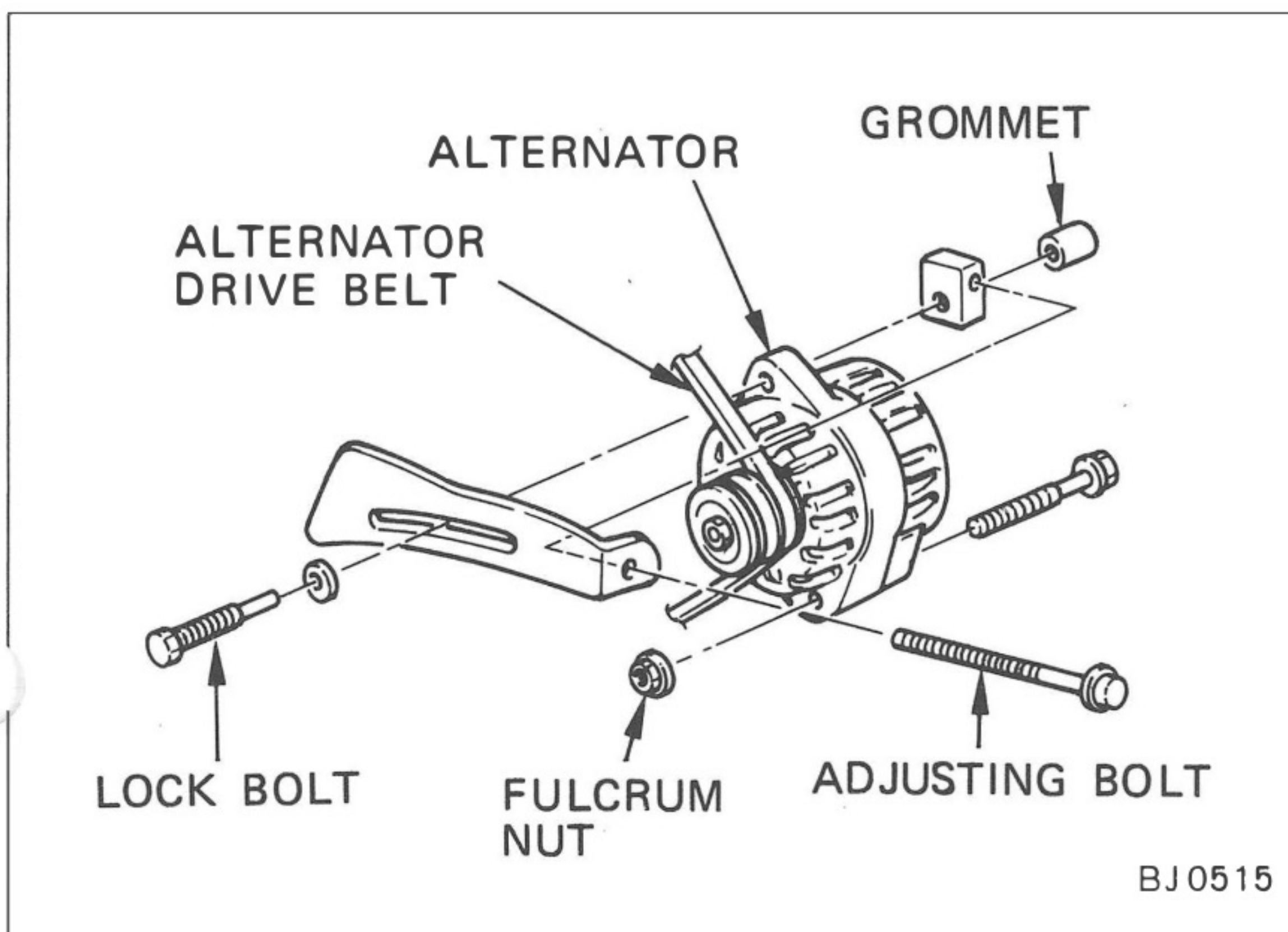

Fig.84

Drive belt		Belt deflection
Alternator drive belt	Used belt	45 ± 10 kg (99 ± 22 lbs)
Compressor drive belt	New belt	50 ± 10 kg (110 ± 22 lbs)
	Used belt	30 ± 10 kg (66 ± 22 lbs)
P/Spump drive belt	Used belt	45 ± 10 kg (99 ± 22 lbs)

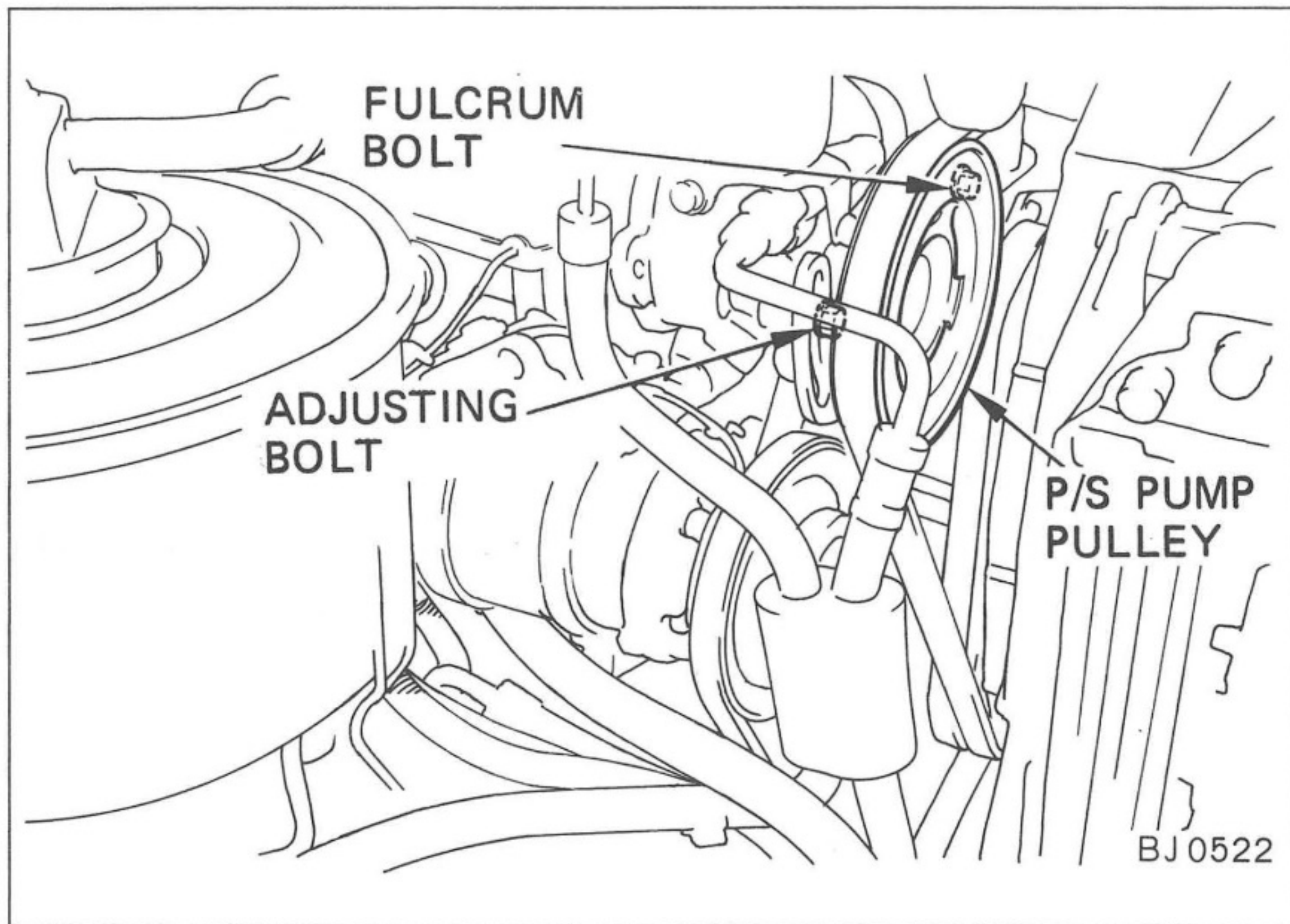

Fig.85

- (i) Tighten the alternater fulcrum bolt, adjusting bolt and idle pulley lock nut.

Tightening Torque: Fulcrum bolt  
450 kg-cm (44 N-m, 32 ft-lbs)

Tightening Torque: Adjusting bolt  
375 kg-cm (37 N-m, 27 ft-lbs)

- (i) Tighten the P/S pump fulcrum nut and adjusting bolt.

Tighten Torque: Fulcrum bolt  
590 kg-cm (58 N-m, 42 ft-lbs)

Tightening Torque: Adjusting bolt  
185 kg-cm (18 N-m, 13 ft-lbs)

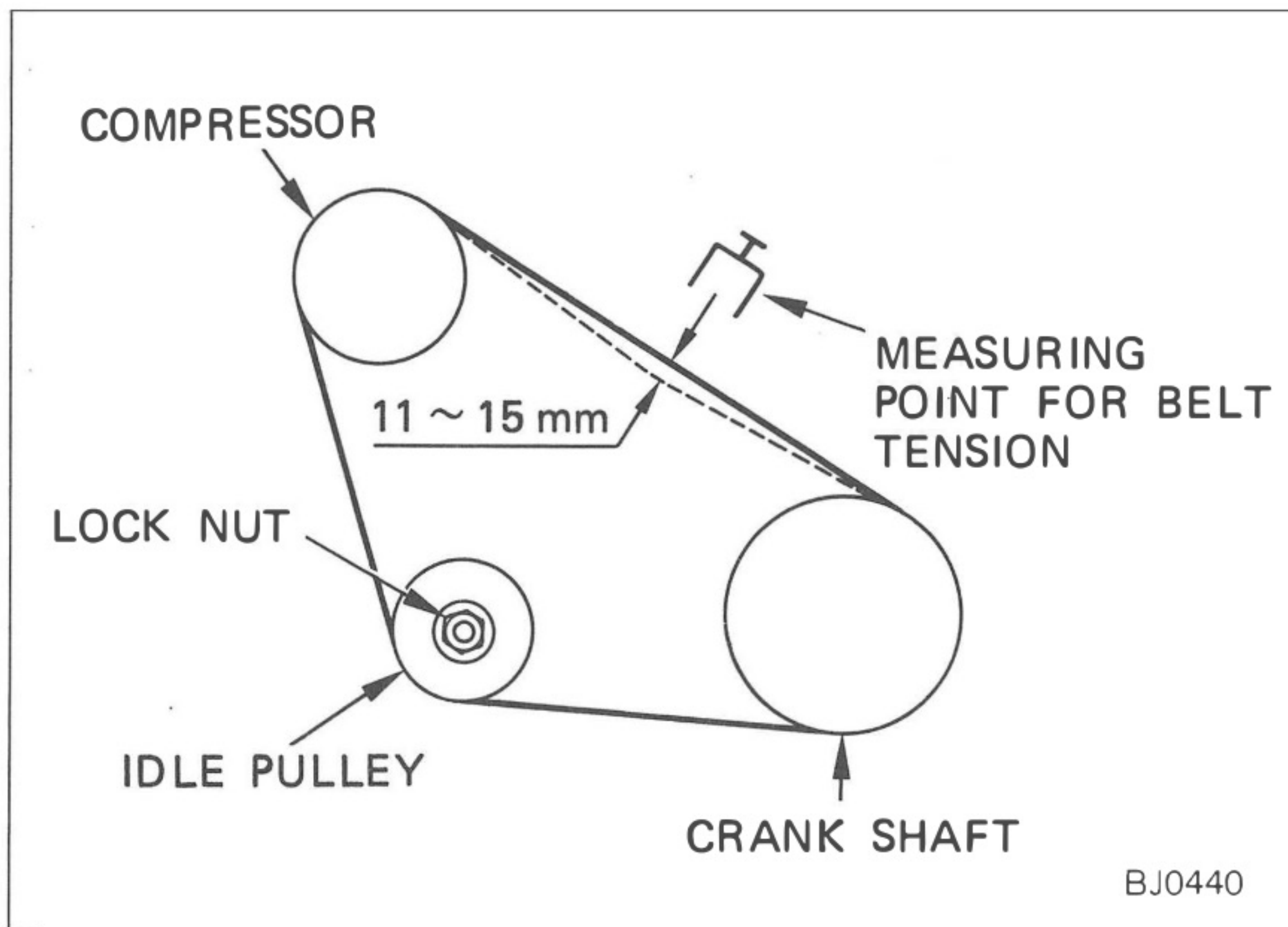

Fig.86

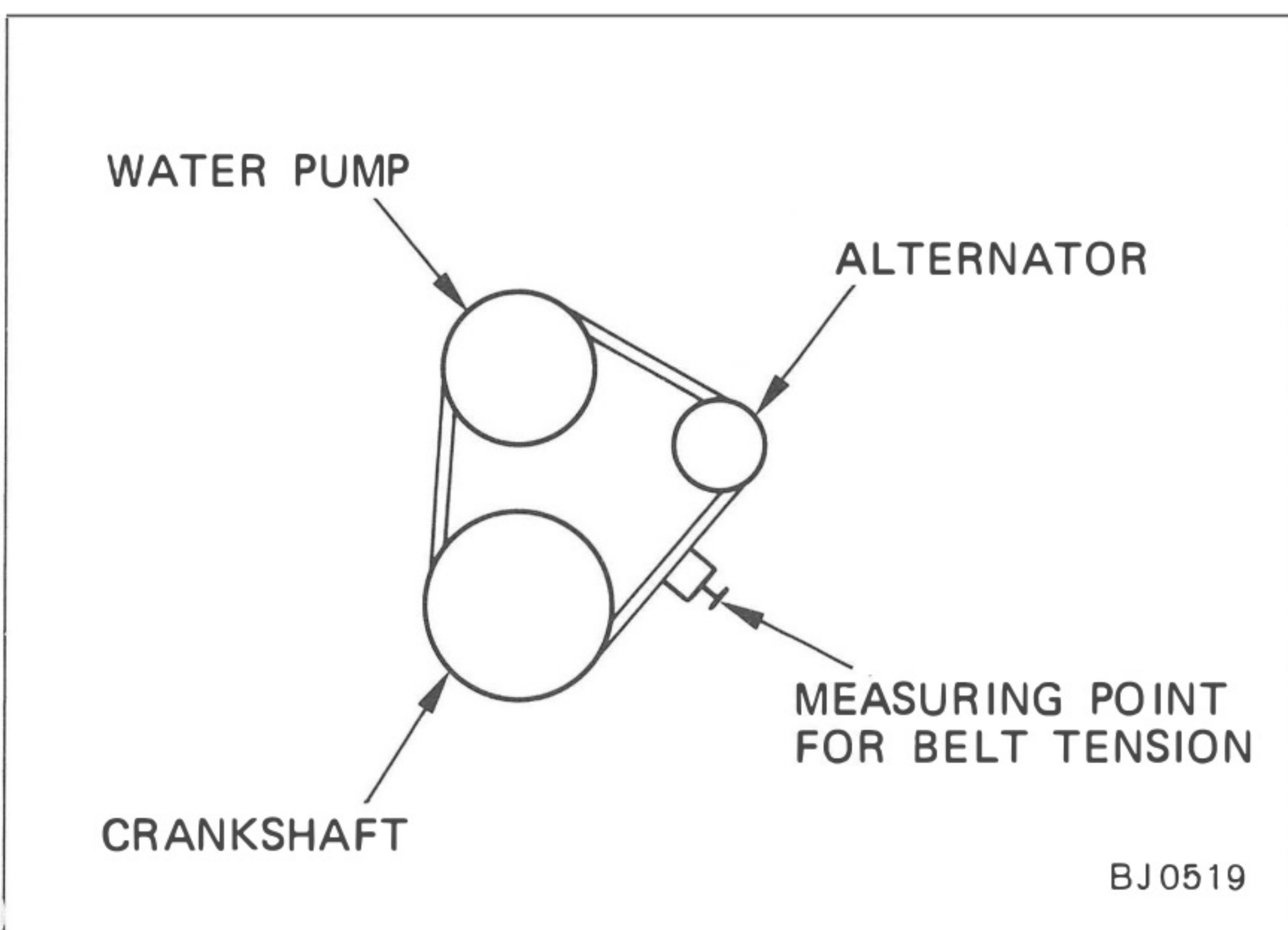

Fig.87

■ FOR 3F-E ENGINES ONLY

- (k) Install the compressor drive belt, and adjust the belt tension by turning the adjusting bolt.
- (l) Check the belt tension using a Burroughs Drive Belt Tension Gauge (No. BT-33-73F) or a NIPPONDENSO BTG-20.

	Belt deflection at 10kg (22lbs) force	Belt tension using the belt tension gauge
New belt	11 - 15 mm (0.43-0.59 inch)	50 ± 10 kg (110 ± 22 lbs)
Used belt	15 - 21 mm (0.59-0.82 inch)	30 ± 10 kg (66 ± 22 lbs)

- (m) Tighten the lock nut.  
Tightening Torque:  
400 kg-cm (39 N-m, 29 ft-lbs)
- (n) Install the alternator drive belt and adjust the belt tension.
- (o) Check the belt tension using a Burroughs Drive Belt Tension Gauge (No. BT-33-73F) or a NIPPONDENSO BTG-20.

Drive belt	Belt tension
Alternator drive belt (Used belt)	30 - 45 kg (66 - 99 lbs)

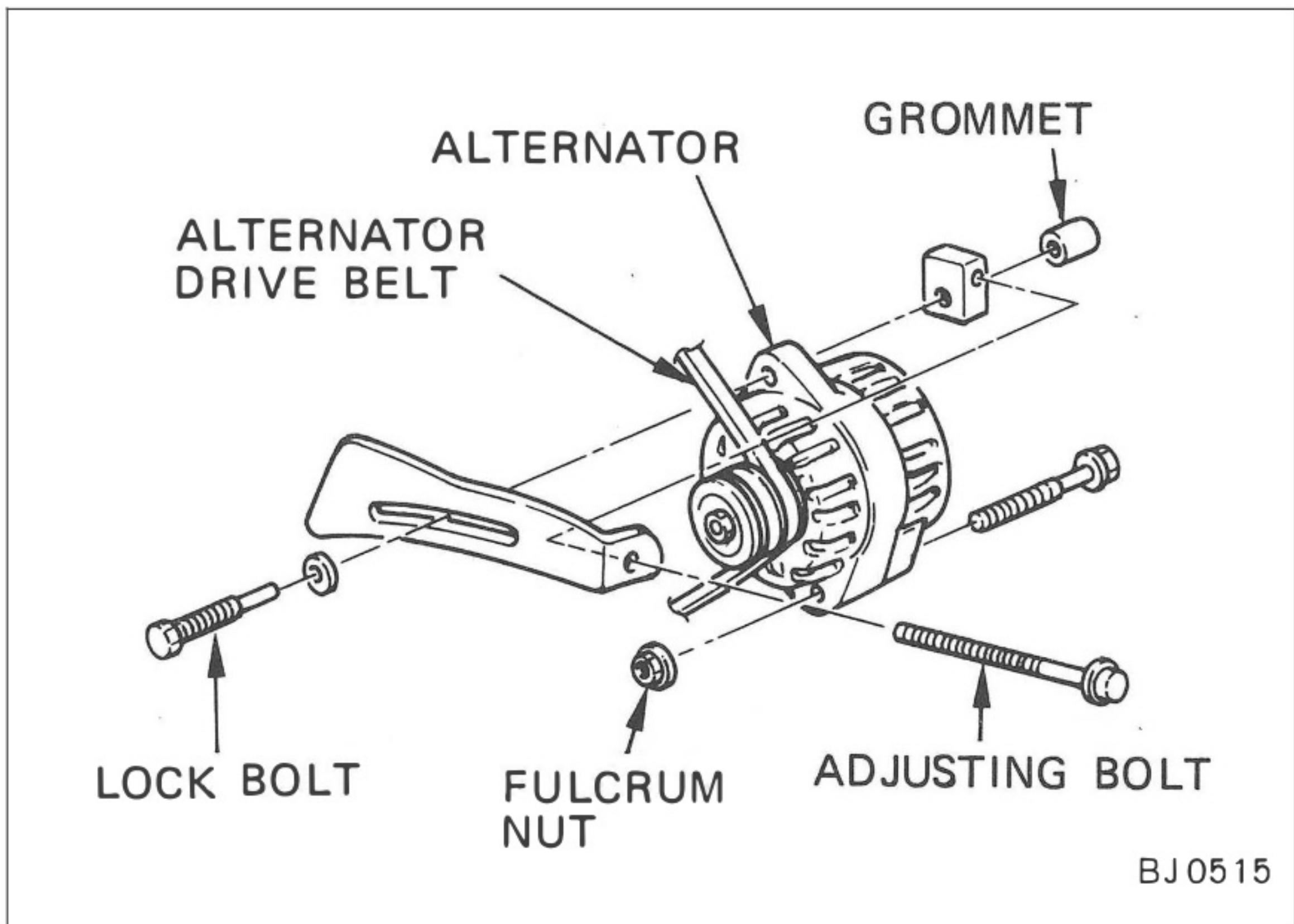

Fig.88

- (o) Tighten the fulcrum nut and adjusting bolt.

Tightening Torque: Fulcrum nut  
590 kg-cm (58 N-m, 42 ft-lbs)

Tightening Torque: Lock bolt  
185 kg-cm (18 N-m, 13 ft-lbs)

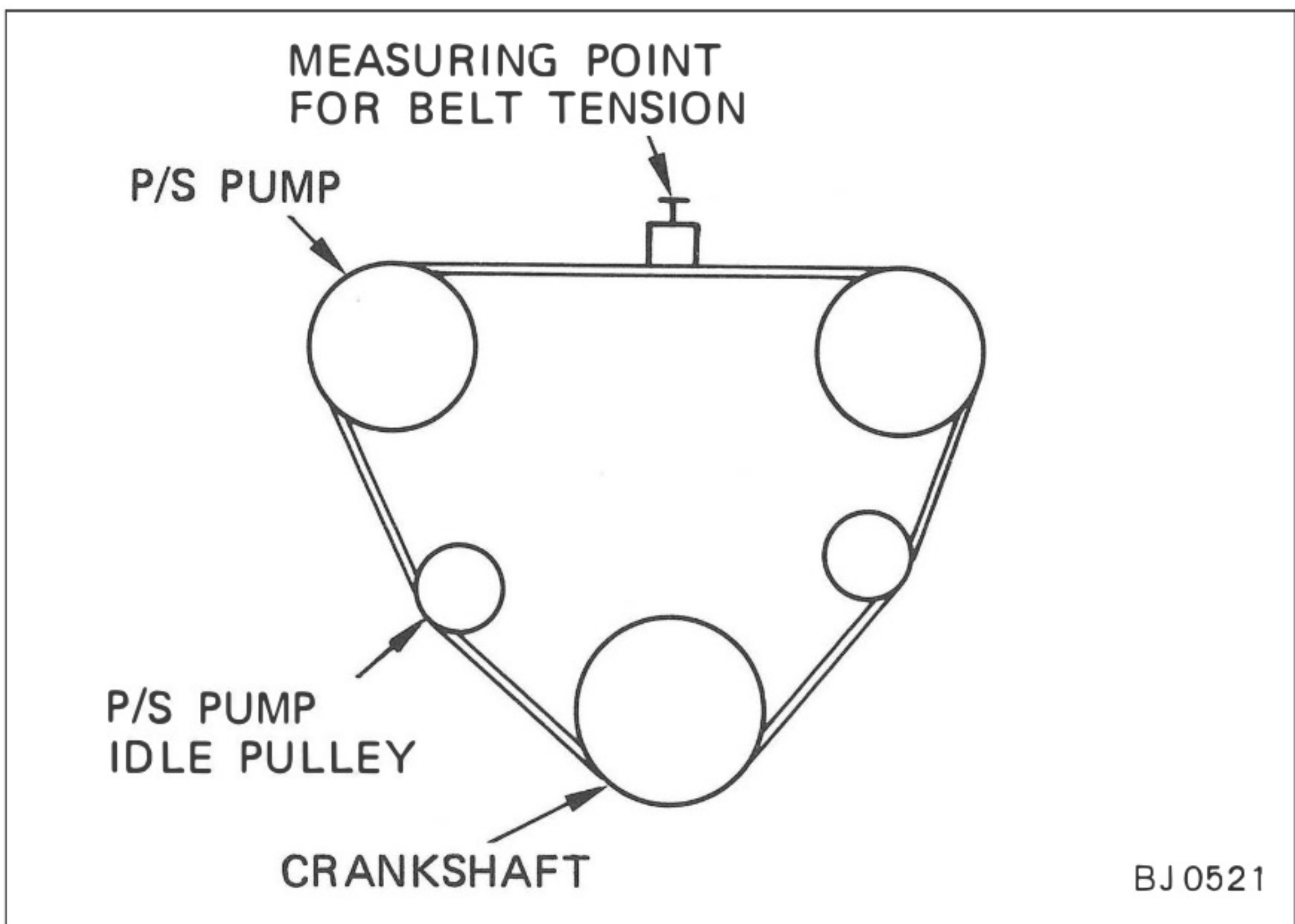

Fig.89

- (p) Install the P/S pump drive belt and adjust the belt tension.
- (q) Check the belt tension using a Burroughs Drive Belt Tension Gauge (No. BT-33-73F) or a NIPPONDENSO BTG-20.

Drive belt	Belt tension
P/S pump drive belt (Used belt)	30 - 45 kg (66 - 99 lbs)

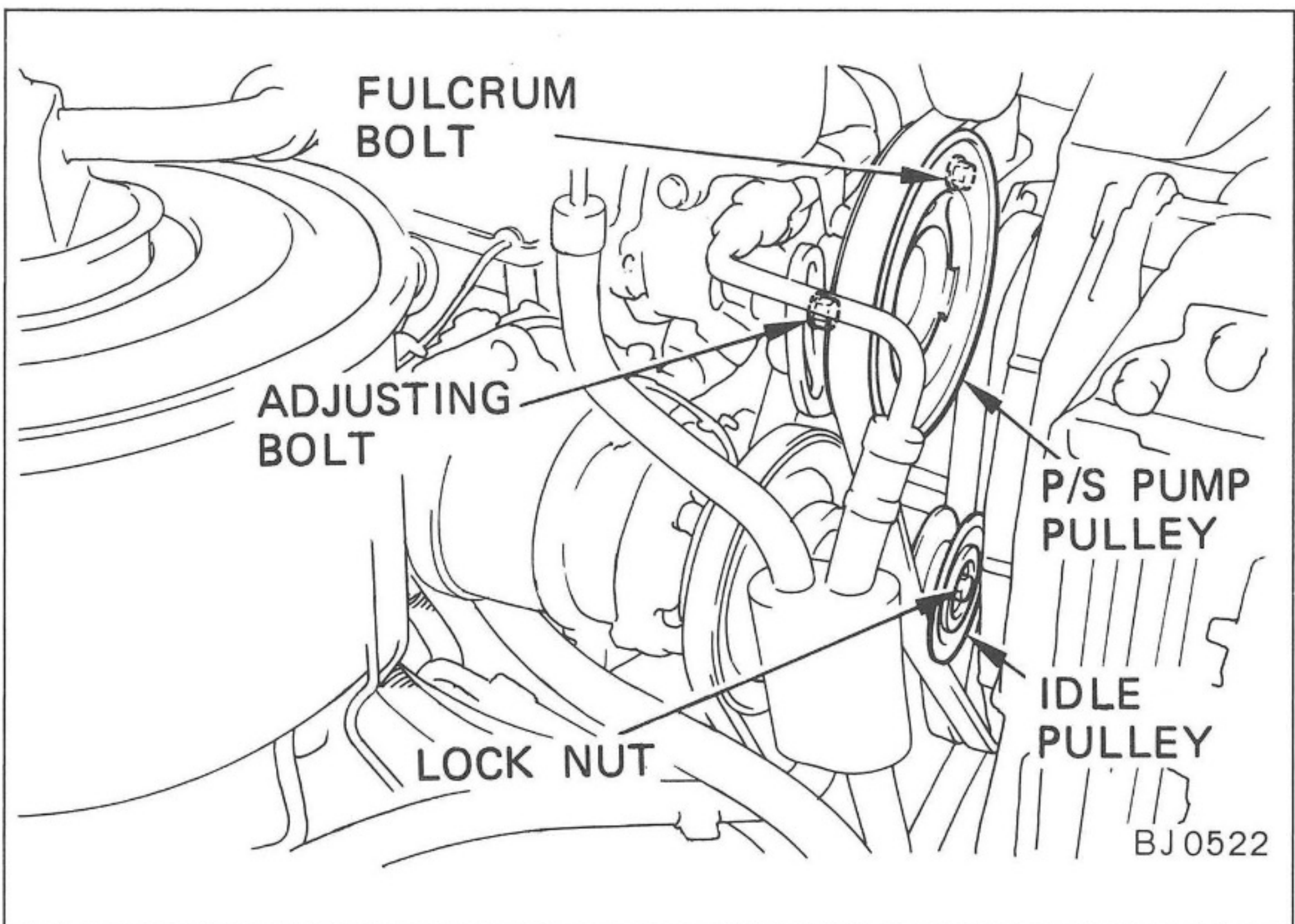

Fig.90

- (r) Tighten the fulcrum bolt, adjusting bolt and idle pulley lock nut.

Tightening Torque: Fulcrum bolt  
450 kg-cm (44 N-m, 32 ft-lbs)

Tightening Torque: Adjusting bolt  
375 kg-cm (37 N-m, 27 ft-lbs)

Tightening Torque: Lock nut  
400 kg-cm (39 N-m, 29 ft-lbs)

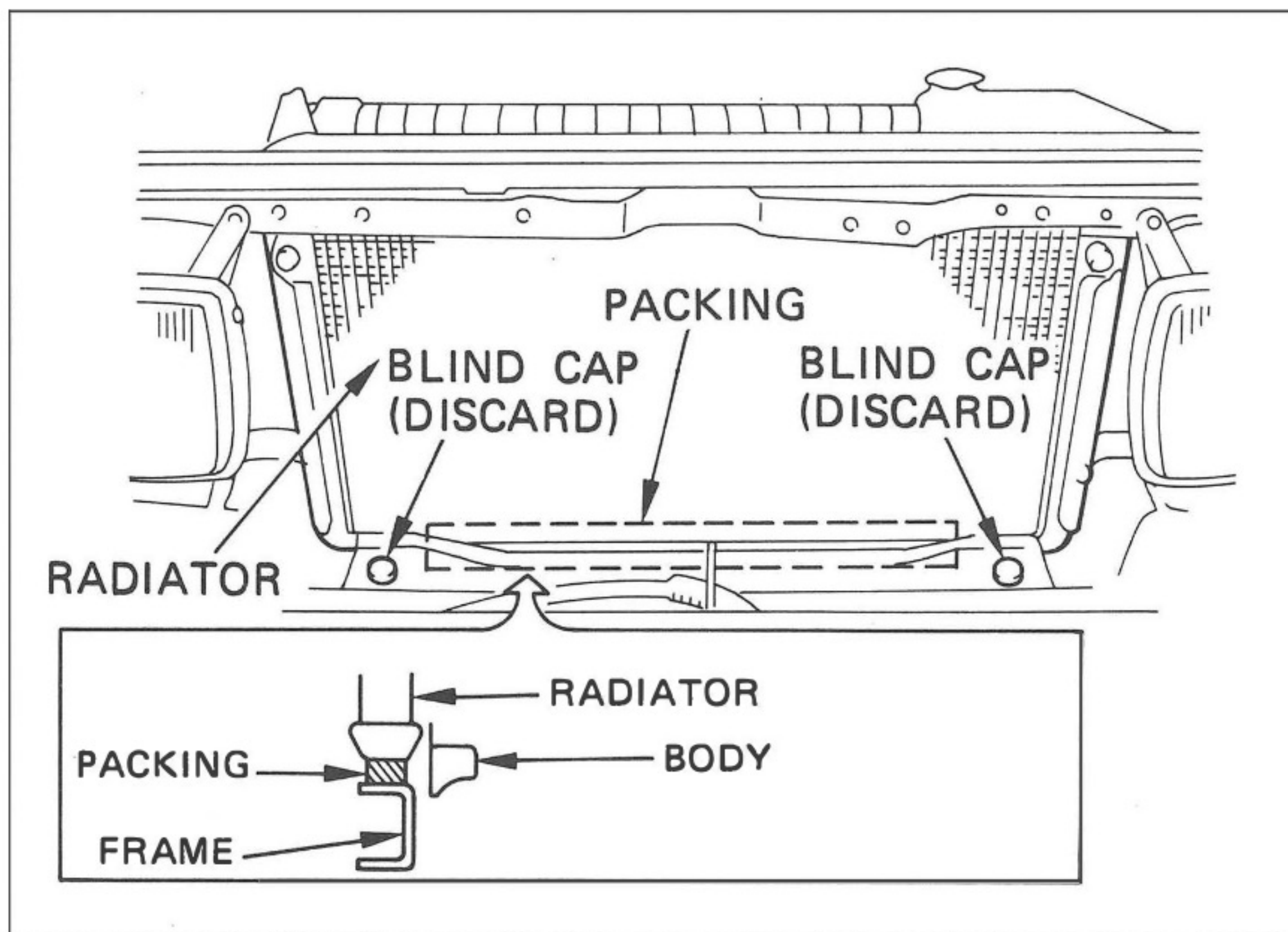

Fig.91

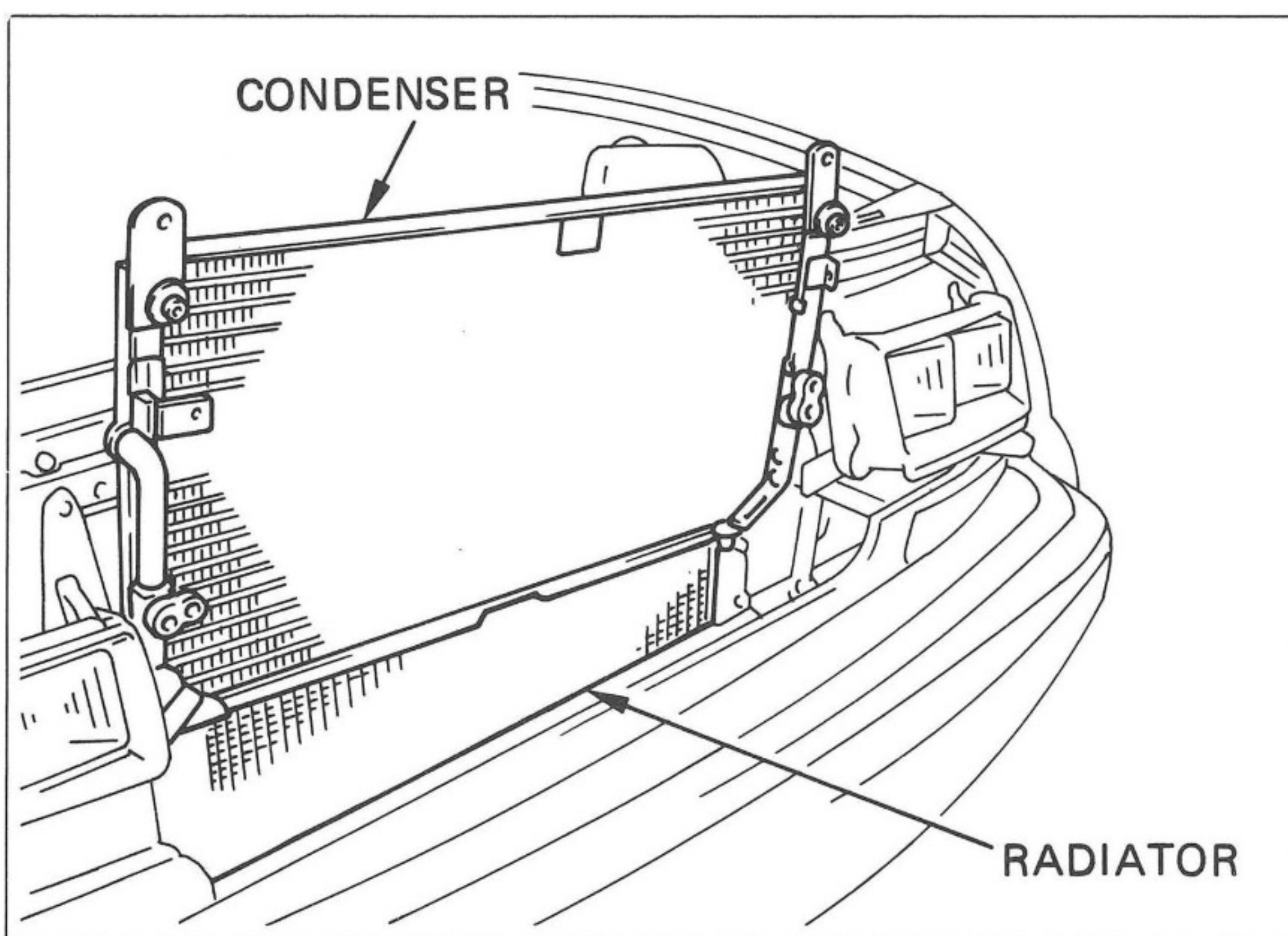

Fig.92

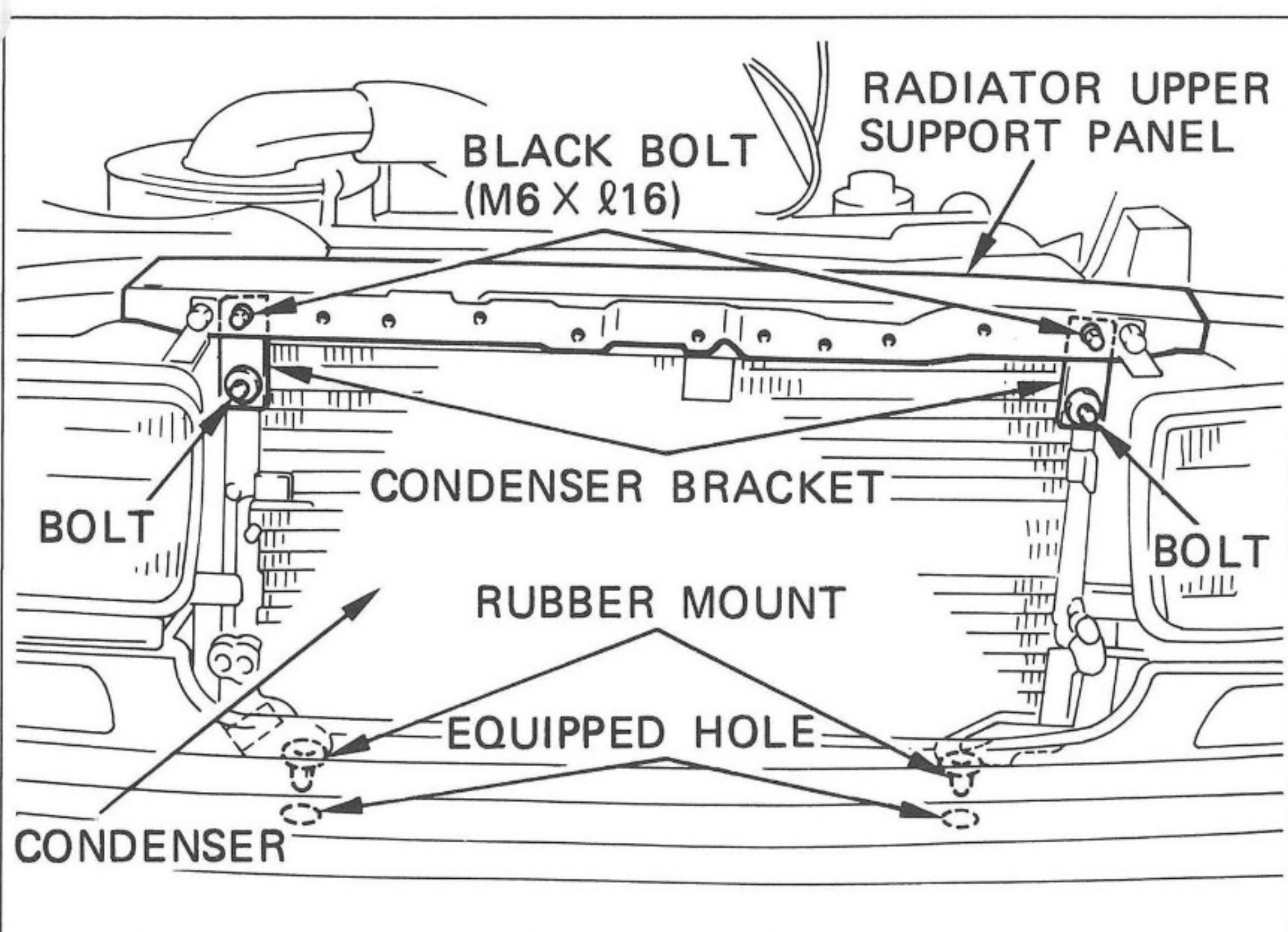

Fig.93

#### (4) CONDENSER

- (a) Attach the packing to the bottom of radiator as shown.
- (b) Remove and discard the blind caps from the frame.

- (c) Slide in the condenser and gently manoeuvre it into its position where the lower mounts, shot into the chassis rail.

- (d) Reinstall the radiator upper support panel and connect the horn harness to the horns, and clip in the vehicle harness to the radiator upper support panel.
- (e) Fasten the two condenser brackets to the radiator upper support panel using two bolts.
- (f) Fasten the two condenser brackets to the condenser.

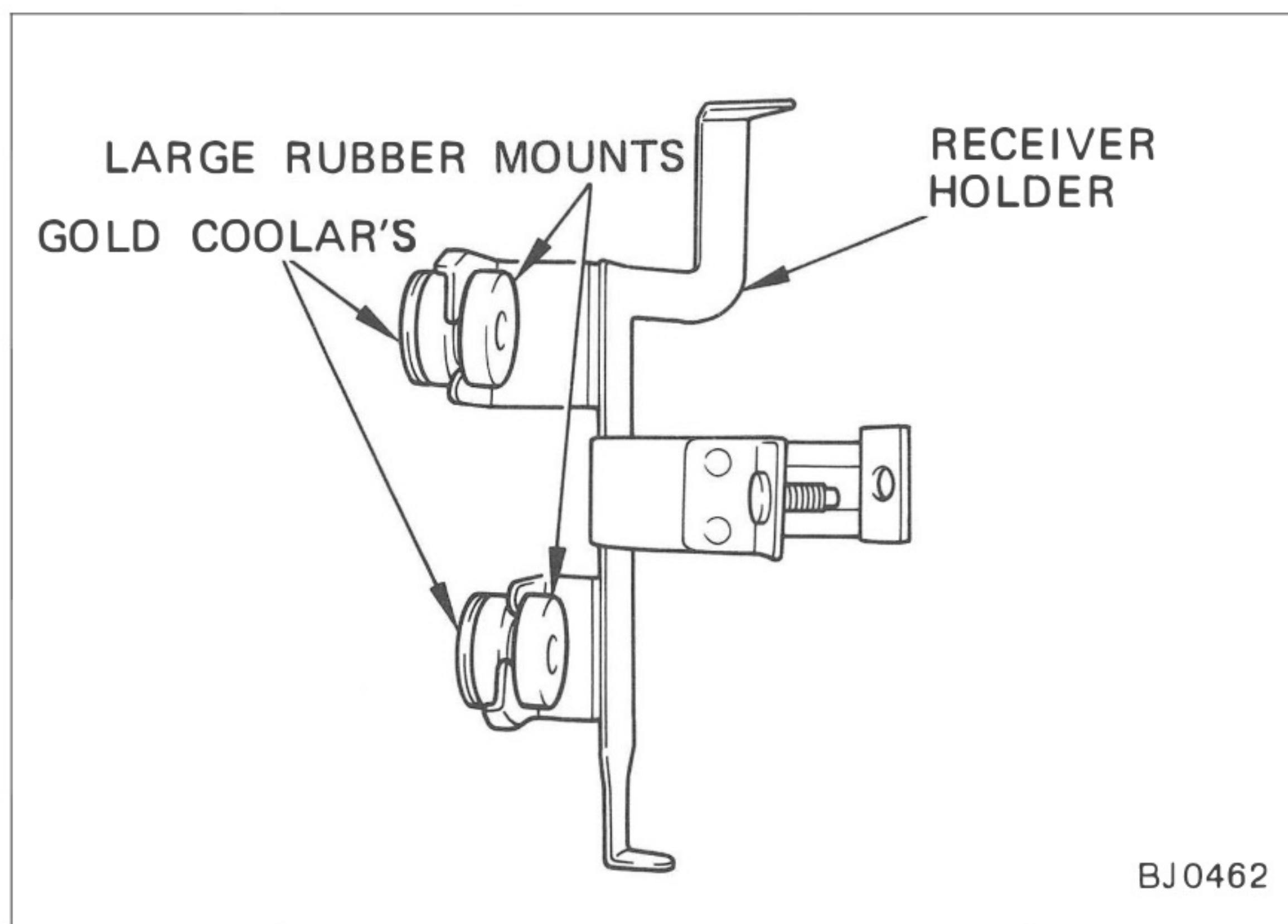

Fig.94

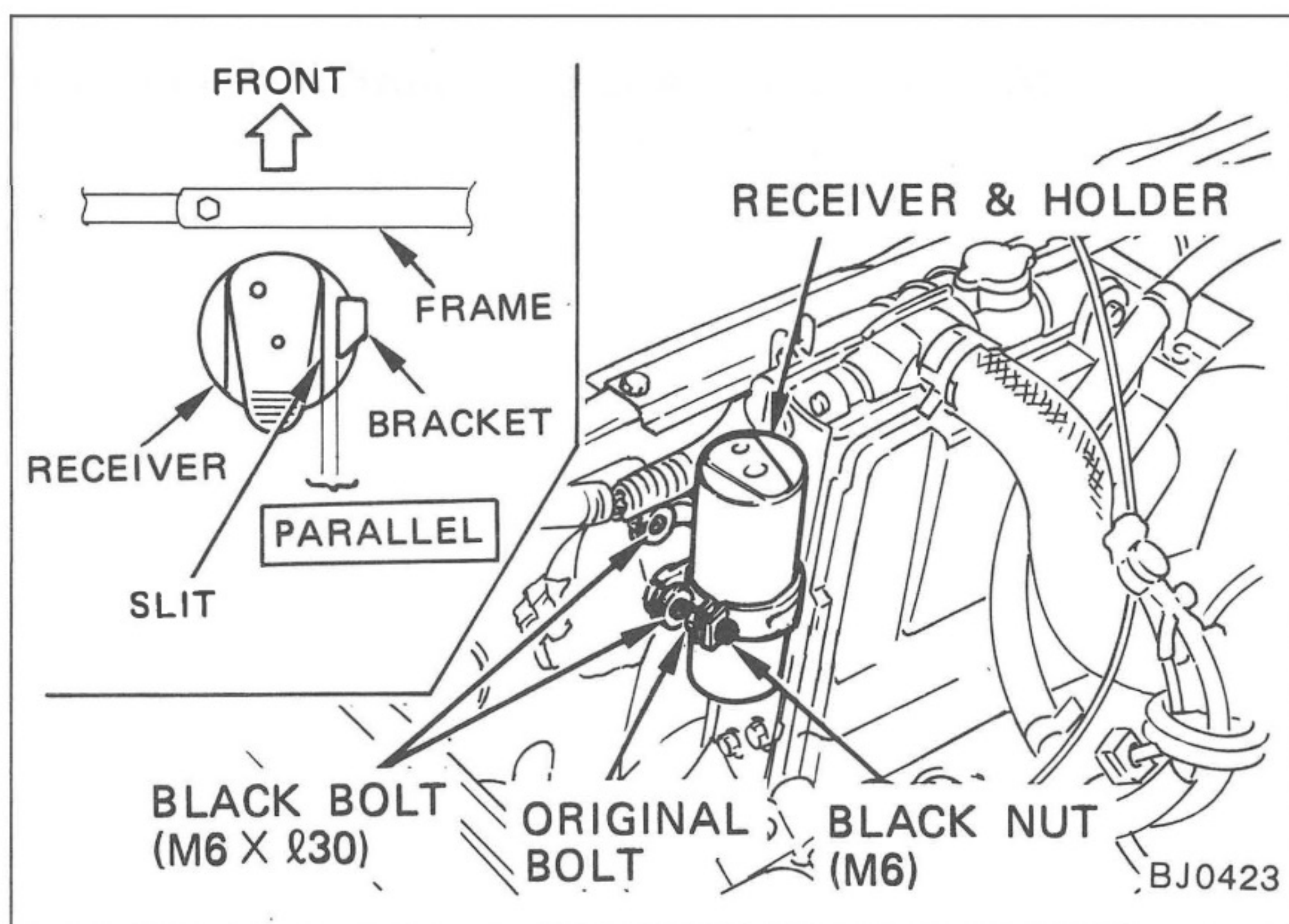

Fig.95

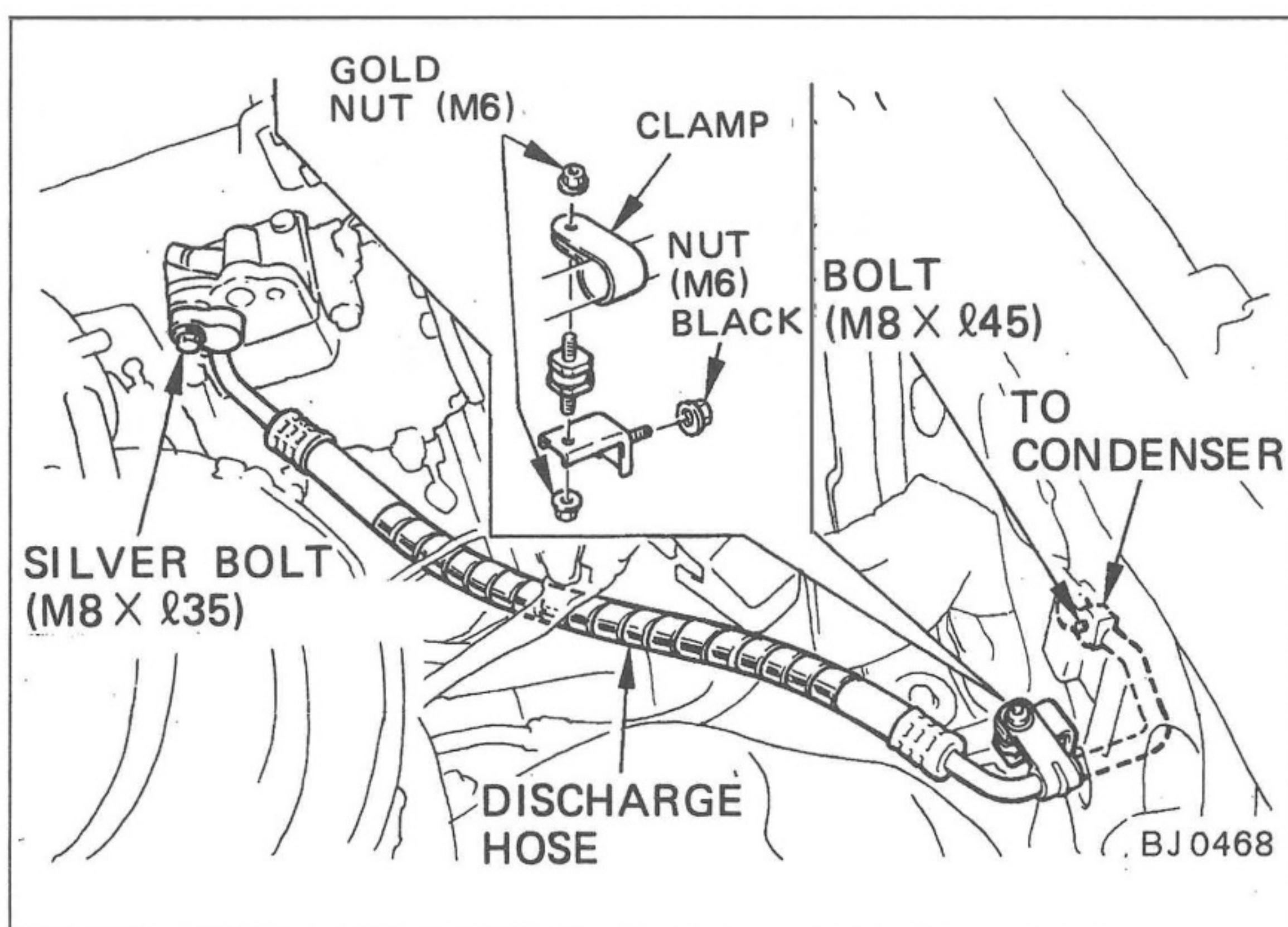

Fig.96

## (5) RECEIVER

- (a) Assemble two large rubber mounts and two gold collars to the receiver holder as shown.

- (b) Install the receiver holder to the radiator support panel using two bolts.
- (c) Position the receiver driver in the holder and fasten with a nut.

## (6) DISCHARGE HOSE

- (a) Assemble the clamp, rubber mount, and bracket to the discharge hose.
- (b) Connect the discharge hose to the condenser. Tightening Torque: 185 kg-cm (18 N-m, 13 ft-lbs)
- (c) Connect the discharge hose to the compressor. Tightening Torque: 250 kg-cm (24 N-m, 18 ft-lbs)
- (d) Connect the vehicle harness to the magnetic clutch lead wire and secure it to the discharge hose using a plastic tie.
- (e) Fasten the clamp to the radiator support panel using a nut.

### HINT

Temporarily remove the front R.H.S. indicator assembly to gain access to the black m6 nut.

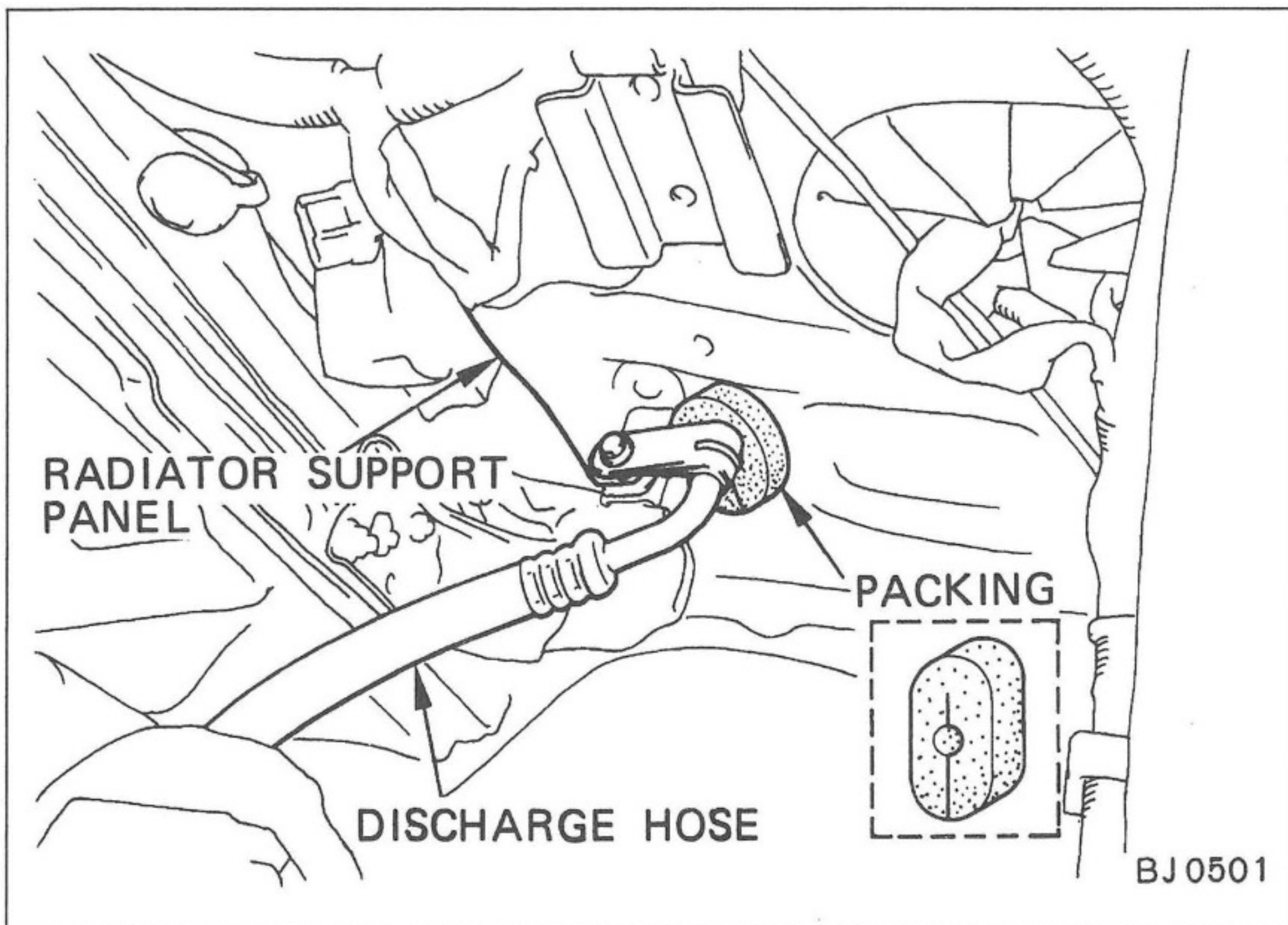

Fig.97

(f) Install packing to the radiator support panel.

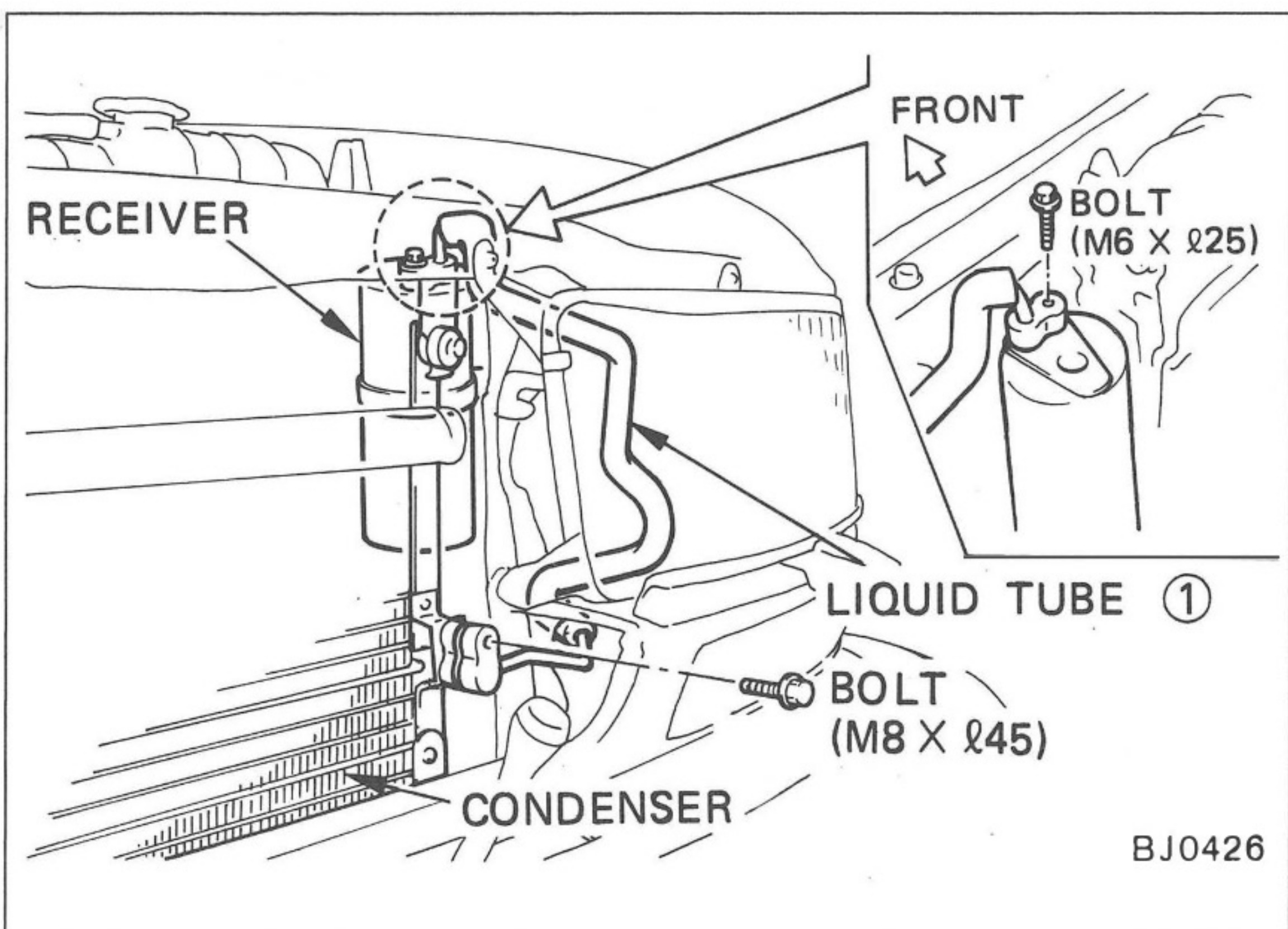

Fig.98

**(7) LIQUID TUBE**

(a) Connect the liquid tube ① from receiver to condenser.

Tightening Torque: Receiver side  
55 kg-cm (5.4 N-m, 4.0 ft-lbs)

Tightening Torque: Condenser side  
185 kg-cm (18 N-m, 13 ft-lbs)

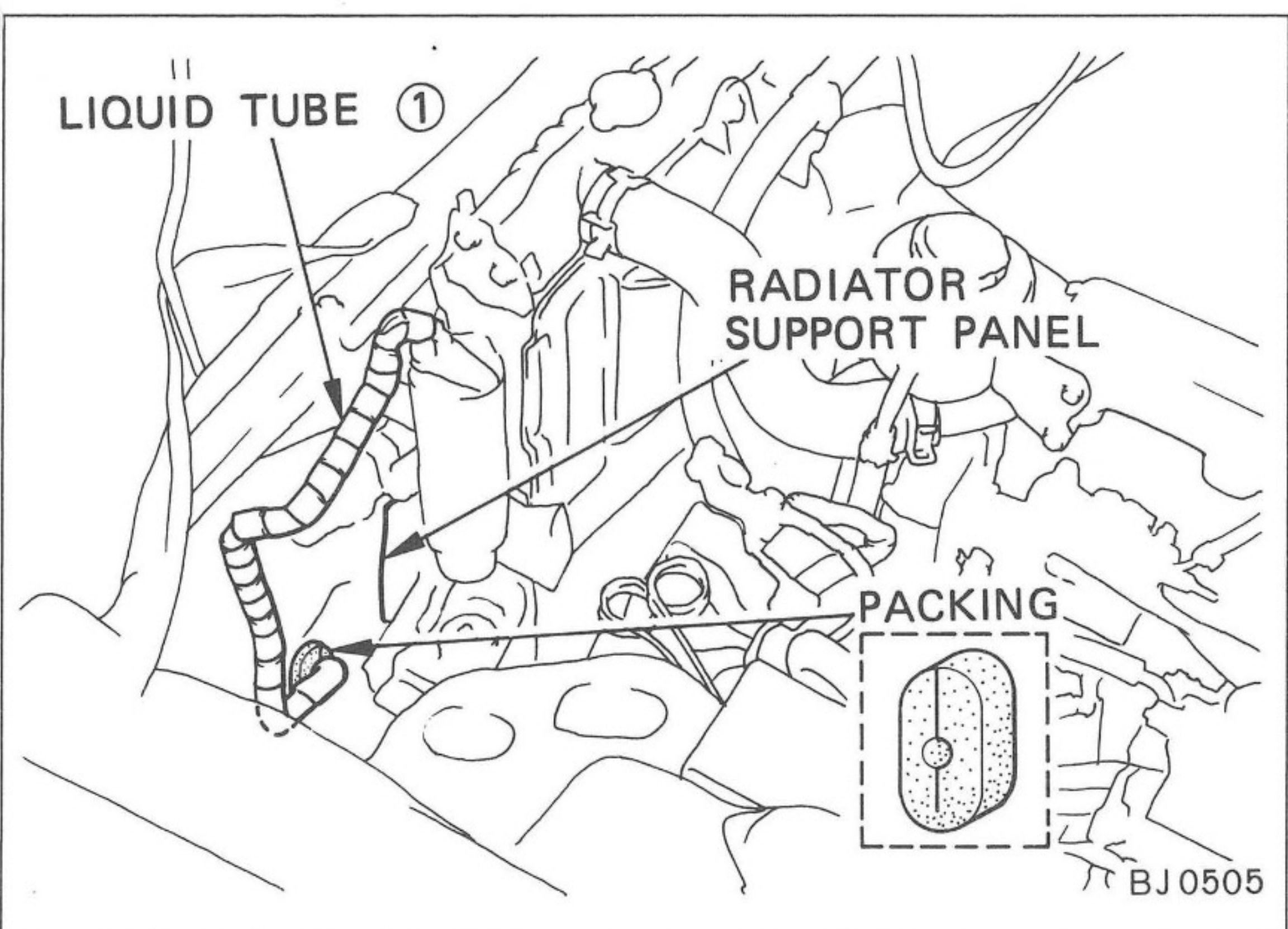

Fig.99

(b) Install the packing into the radiator support panel.

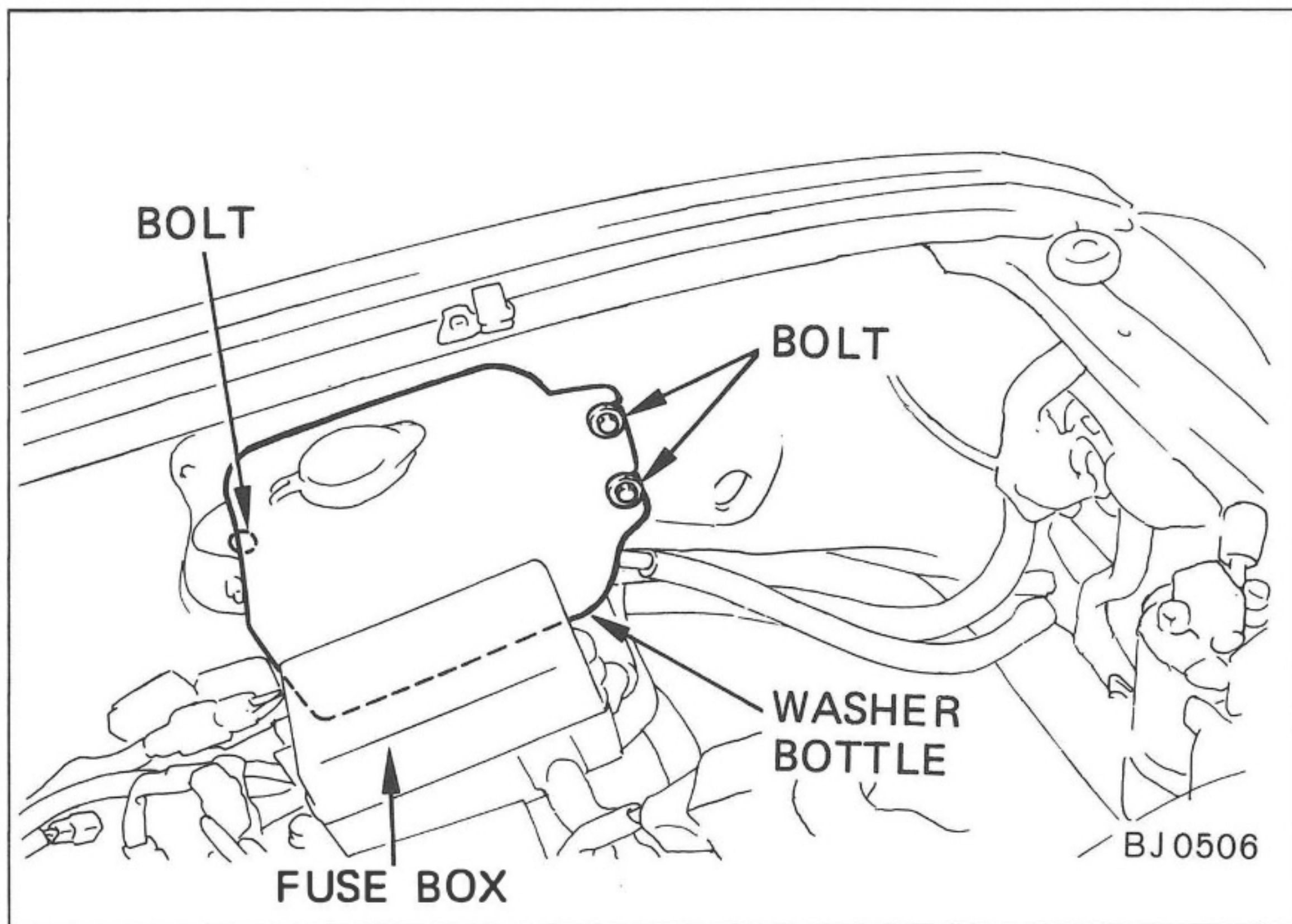

Fig.100

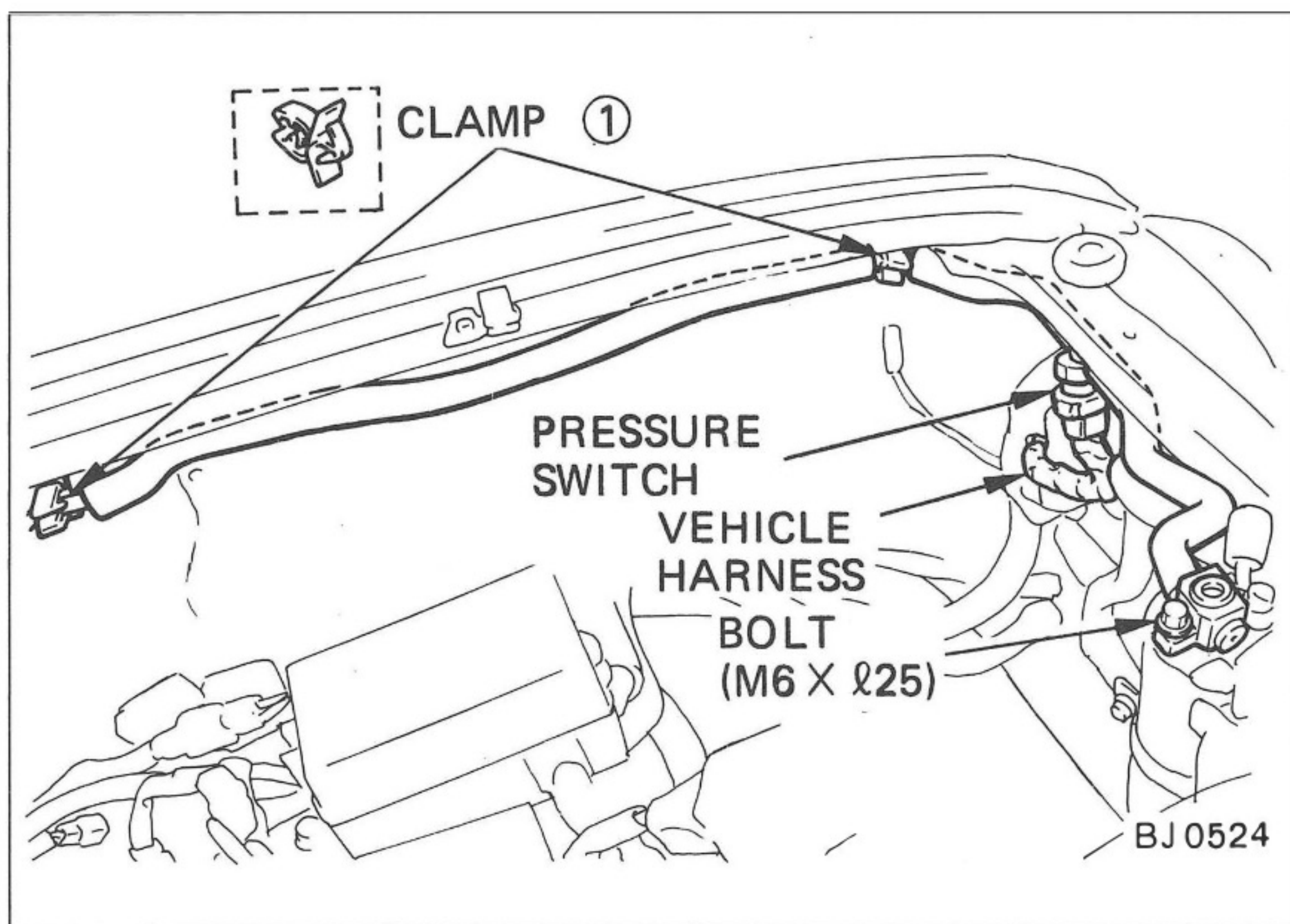

Fig.101

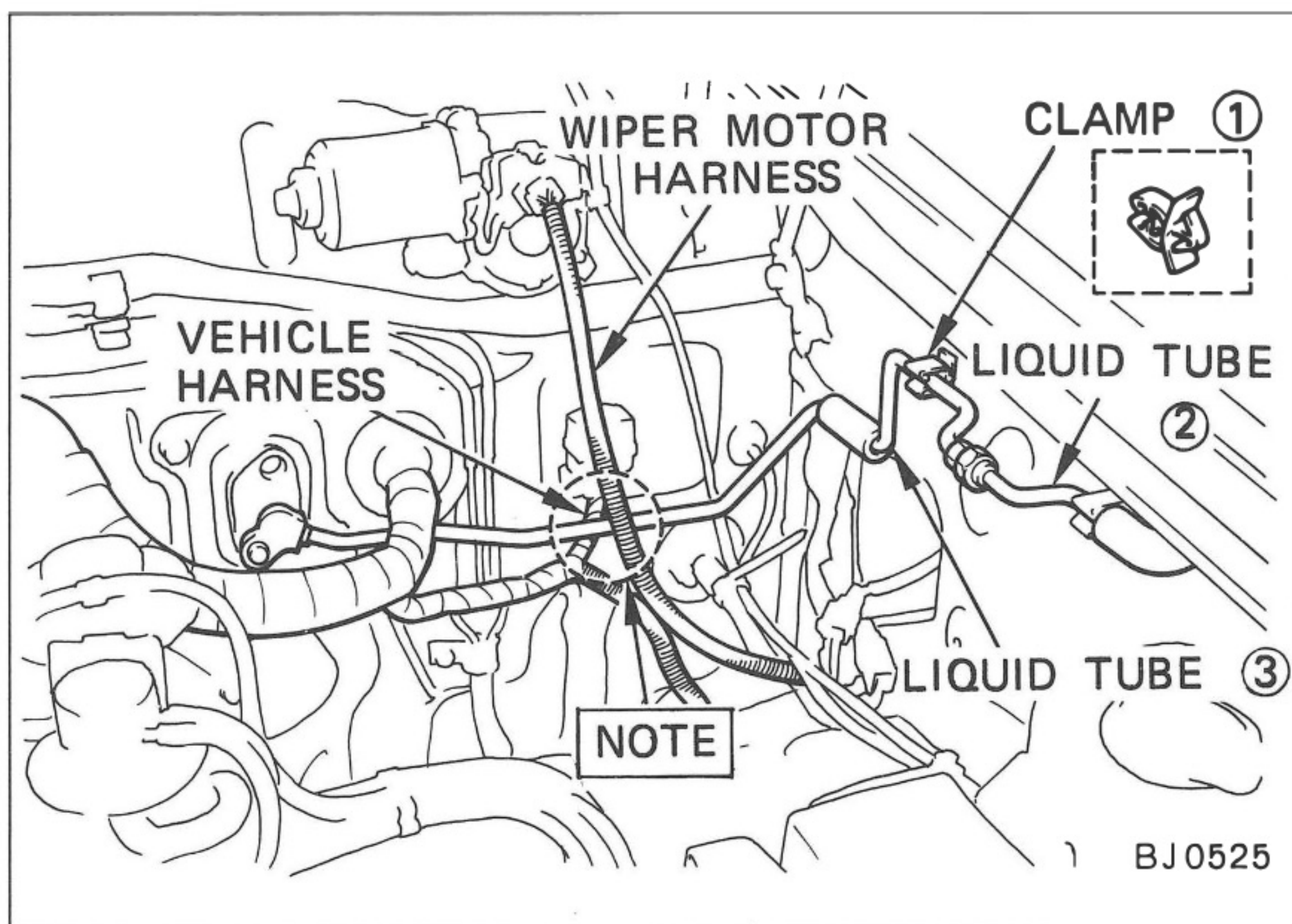

Fig.102

- (c) Temporarily remove the fuse box and washer bottle.

- (d) Install two clamp ① to the left side inner guard.
- (e) Connect the liquid tube ② to receiver.

Tightening Torque: Receiver side  
55 kg-cm (5.4 N-m, 4.0 ft-lbs)

- (f) Fasten the liquid tube ② to the clamp ①.
- (g) Connect the vehicle harness to the pressure switch.

**NOTE**

The 4-P connector is located behind the L.H.S. headlight.

- (h) Install a clamp ① to the left side fender.
- (i) Connect the liquid tube ③ from cooling unit to liquid tube ②.

Tightening Torque: Receiver side  
55 kg-cm (5.4 N-m, 4.0 ft-lbs)

**NOTE**

Route the liquid tube ③ beneath the wiper motor harness and vehicle harness.

- (i) Fasten the liquid tube ③ to the clamp ①.

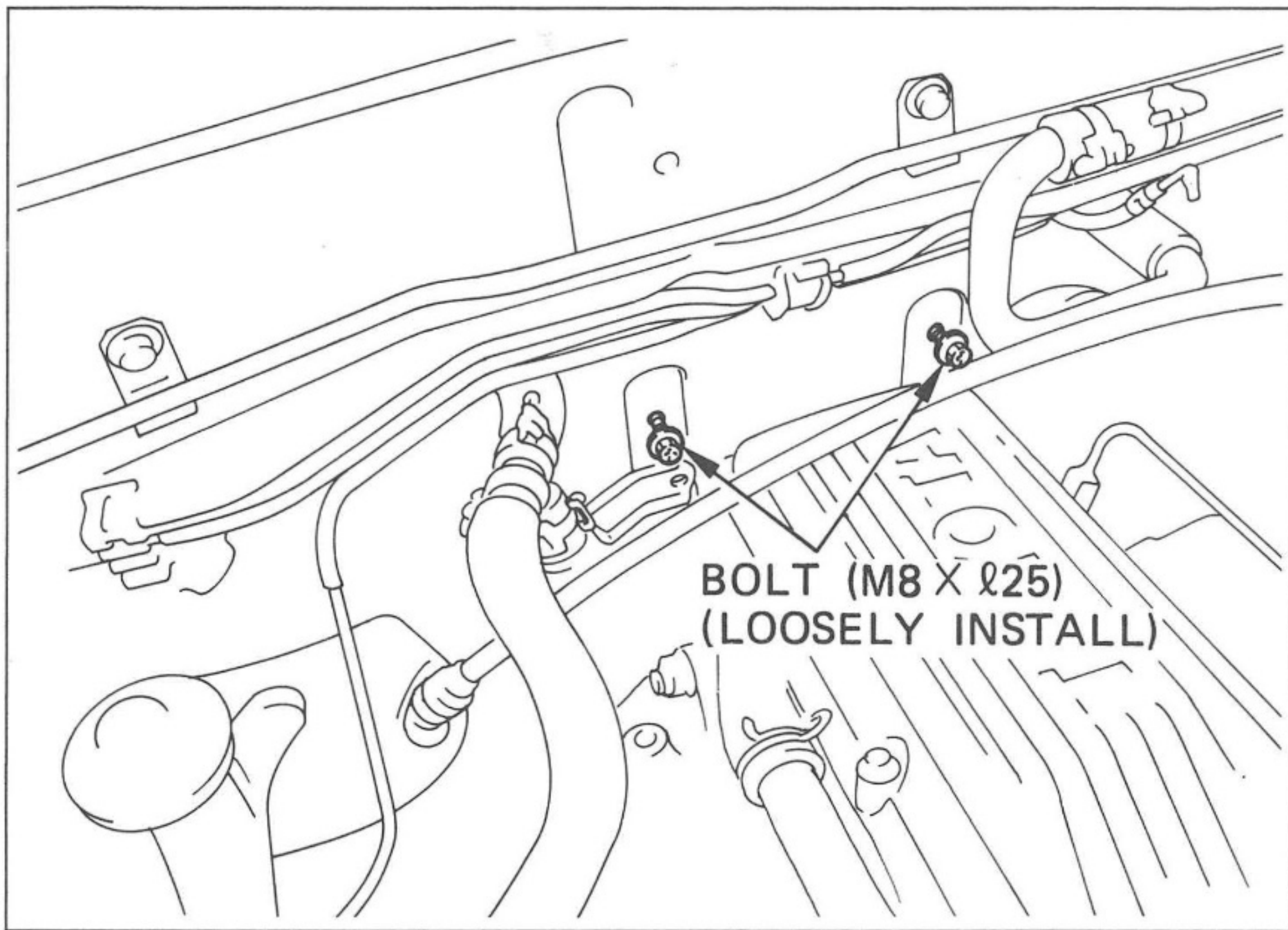

Fig.103

**(8) SUCTION TUBE**

- (a) Loosely install two bolts in place of the original bolts in bulkhead as shown.

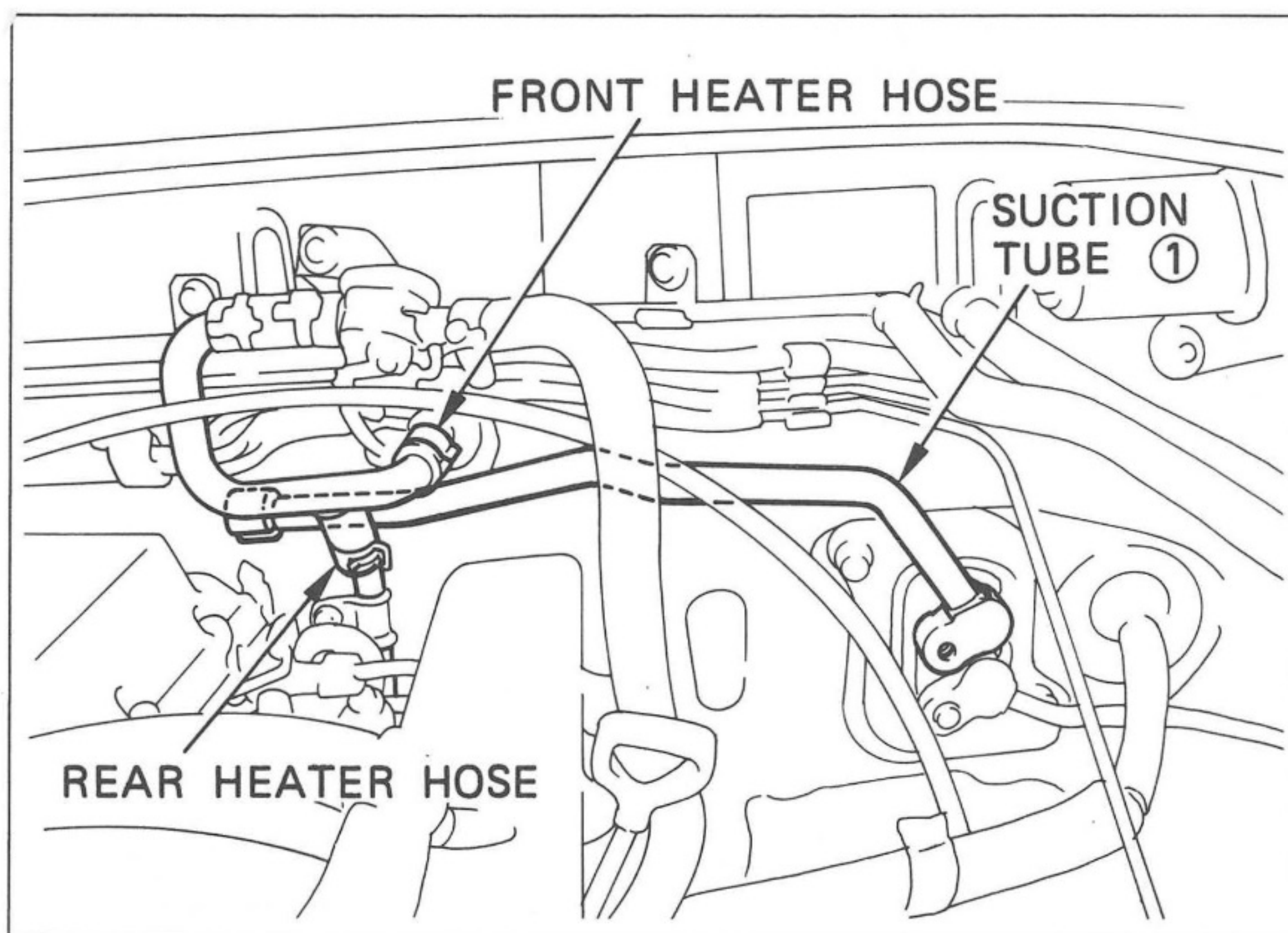

Fig.104

- (b) Route the suction tube ① between the front heater hose and rear heater hose.

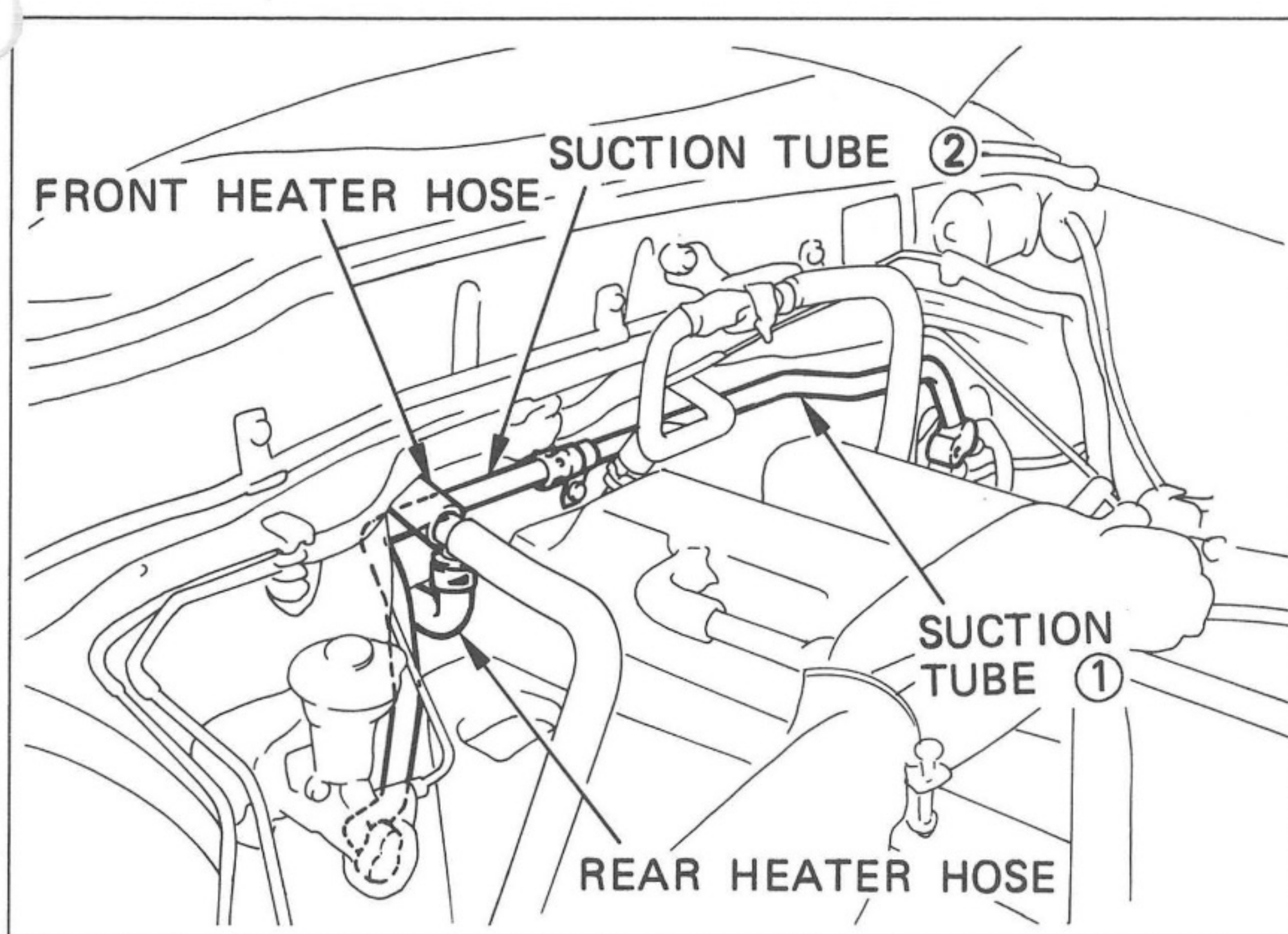

Fig.105

- (c) Route the suction tube ② between the front heater hose and rear heater hose.

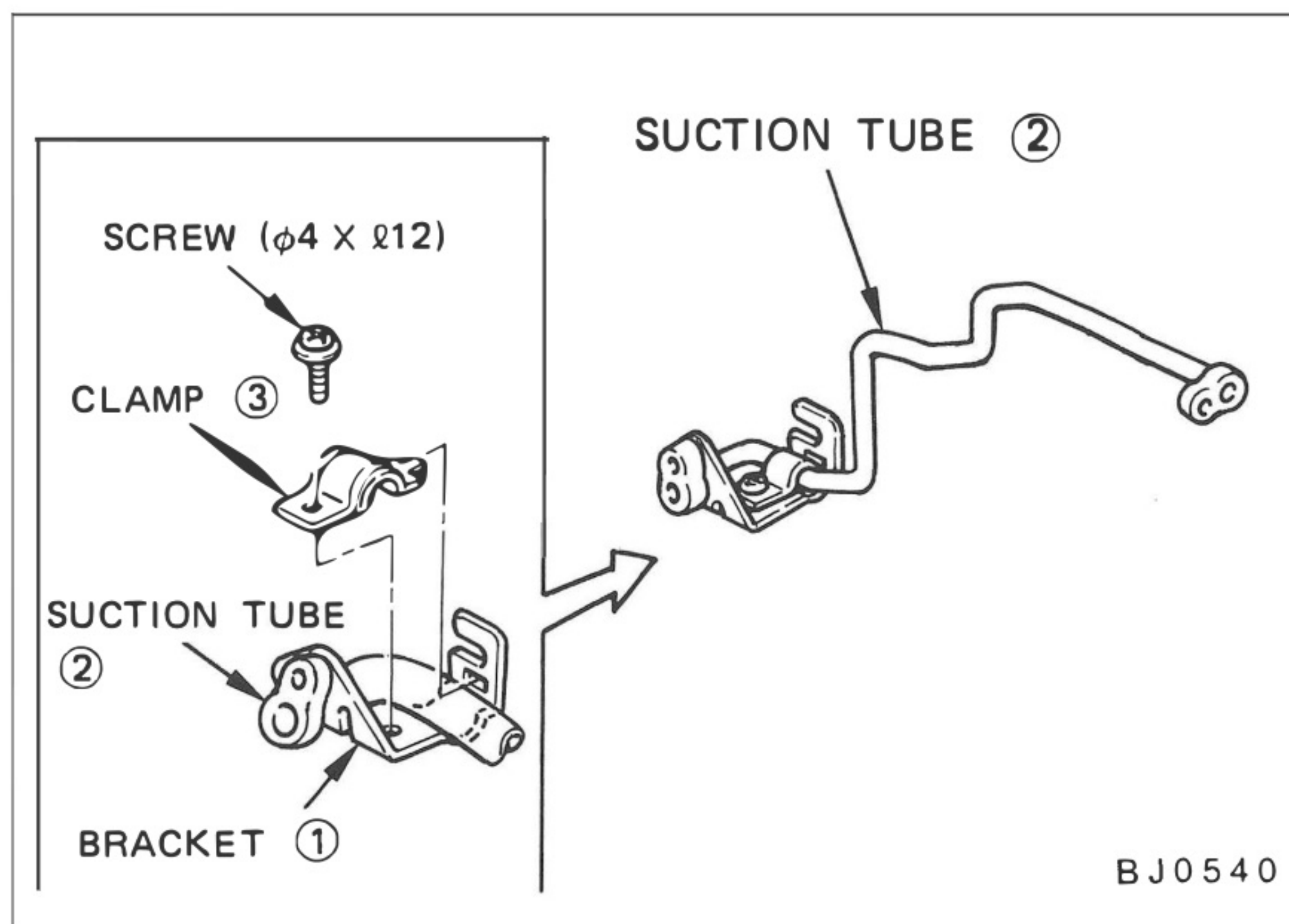

Fig.106

- (d) Install the bracket ① and clamp ③ to the suction tube ② using a screw.

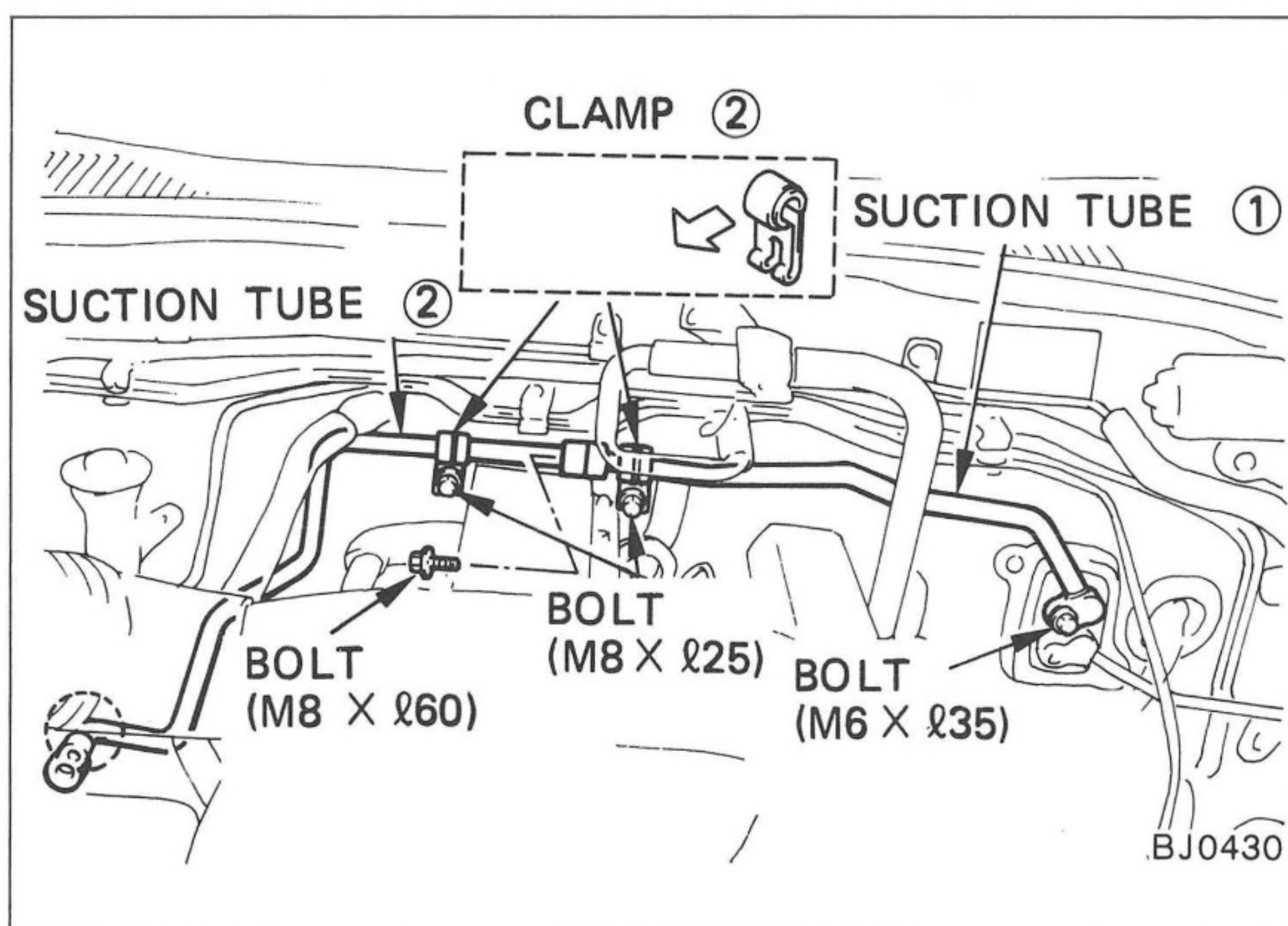

Fig.107

- (e) Loosely install two clamp ② to the suction tube ① and ②.
- (f) Connect the suction tube ① to the cooling unit using a bolt.
- Tightening Torque:  
55 kg-cm (5.0 N-m, 4.0 ft-lbs)

- (g) Connect the suction tube ① to the suction tube ② using a bolt.
- Tightening Torque:  
130 kg-cm (12 N-m, 9 ft-lbs)

- (h) Fasten the suction tube ① and ② using two clamp ② and two bolts loosely installed.

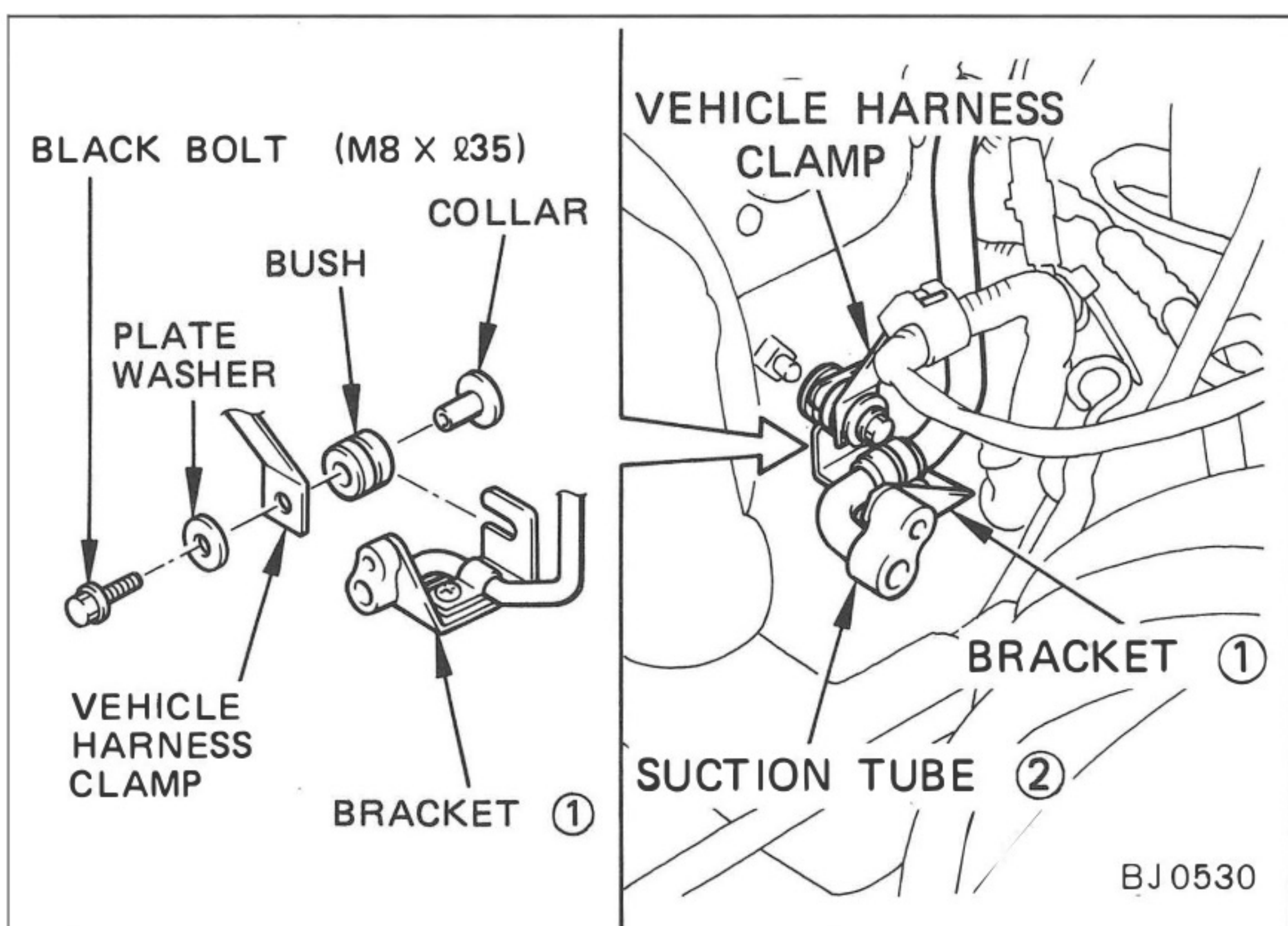

Fig.108

- (i) Assemble the rubber mount and collar to the bracket ① and fasten the suction tube ② together with the vehicle harness clamp using a plate washer and a bolt.

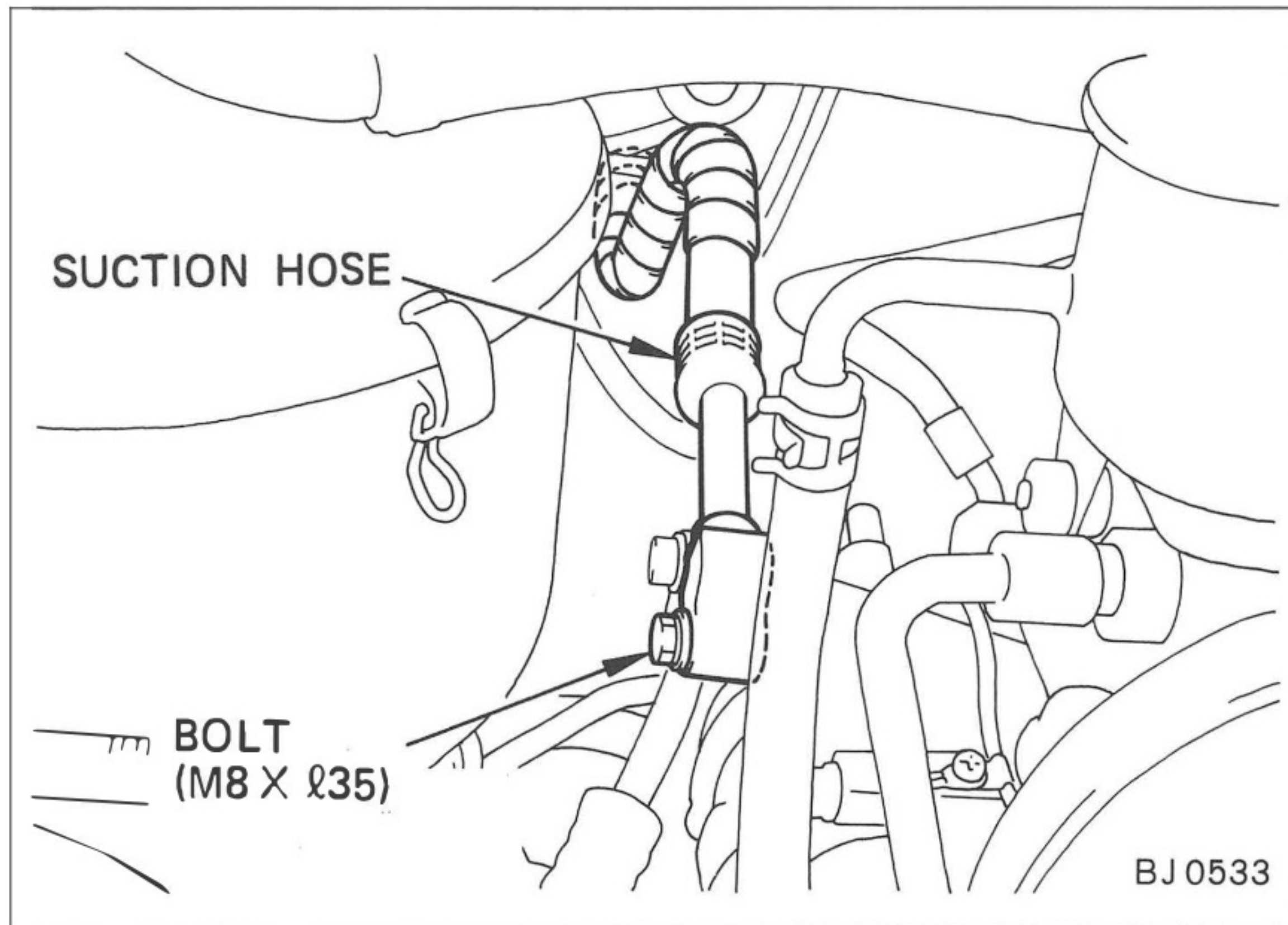

Fig.109

**(9) SUCTION HOSE**

- (a) Connect the suction hose to the compressor using a bolt.

Tightening Torque: Compressor side  
250 kg-cm (24 N-m, 18 ft-lbs)

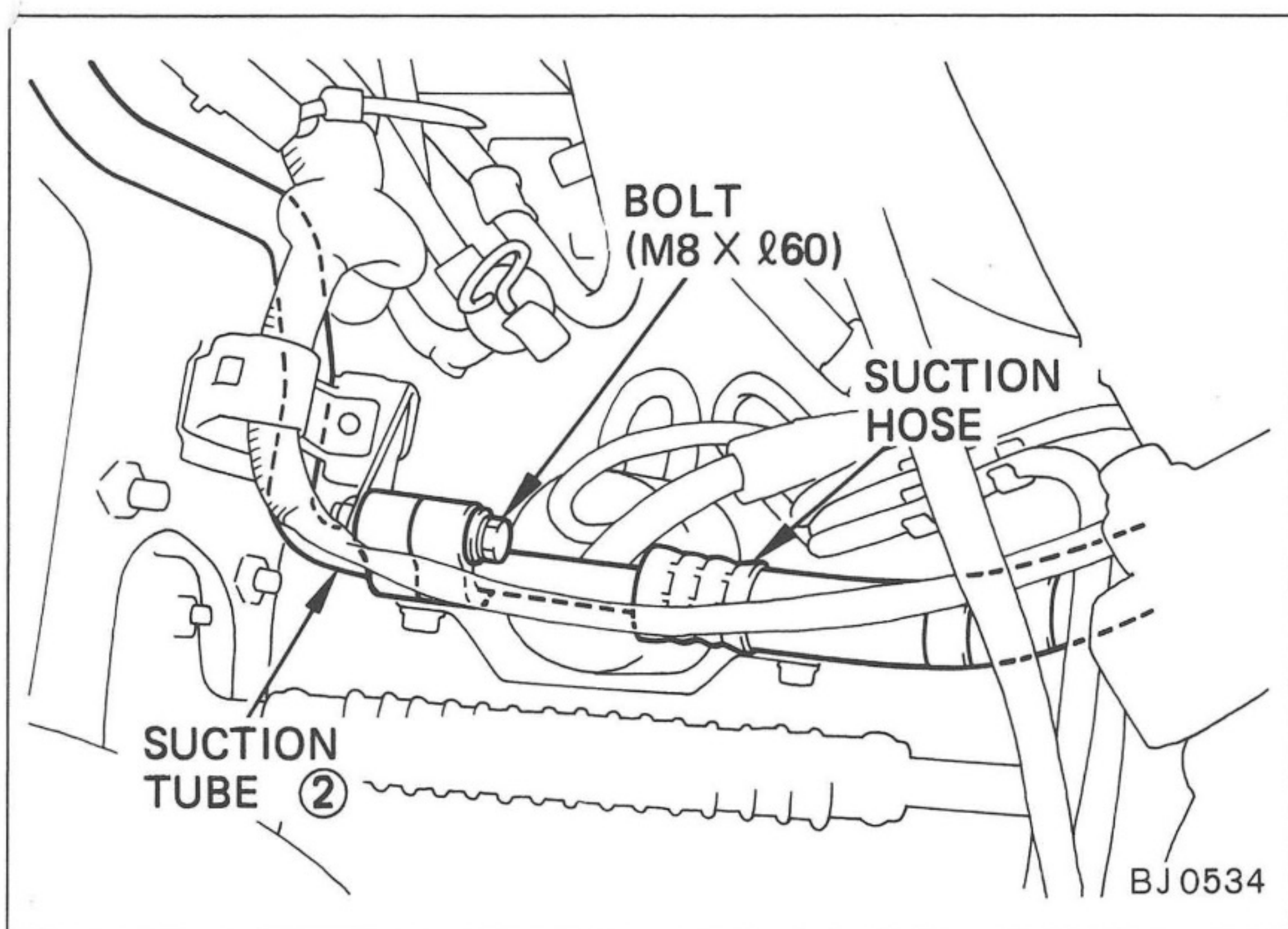

Fig.110

- (b) Connect the suction hose to the suction tube ② using a bolt.

Tightening Torque: Suction tube ②  
185 kg-cm (18 N-m, 13 ft-lbs)

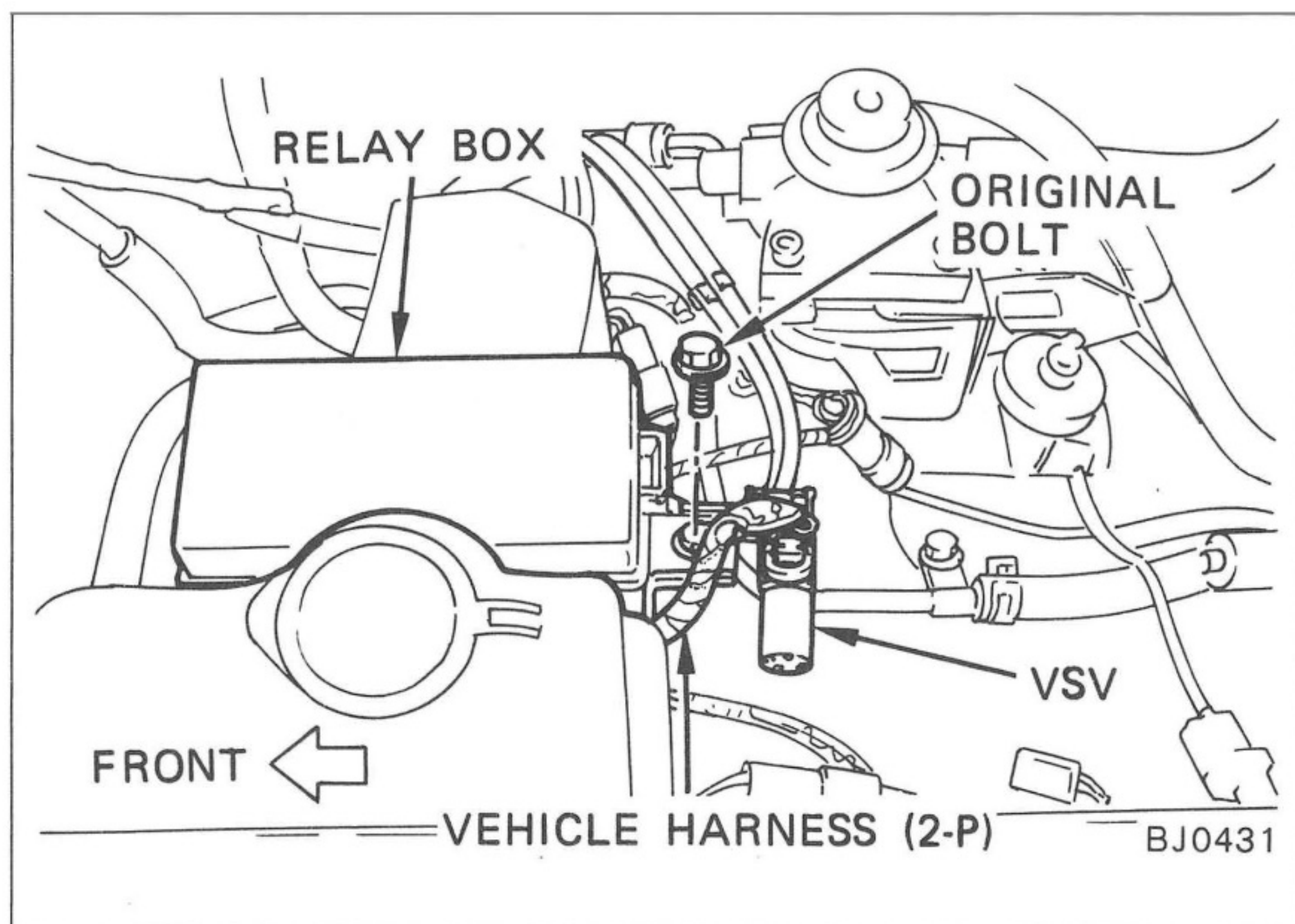

Fig.111

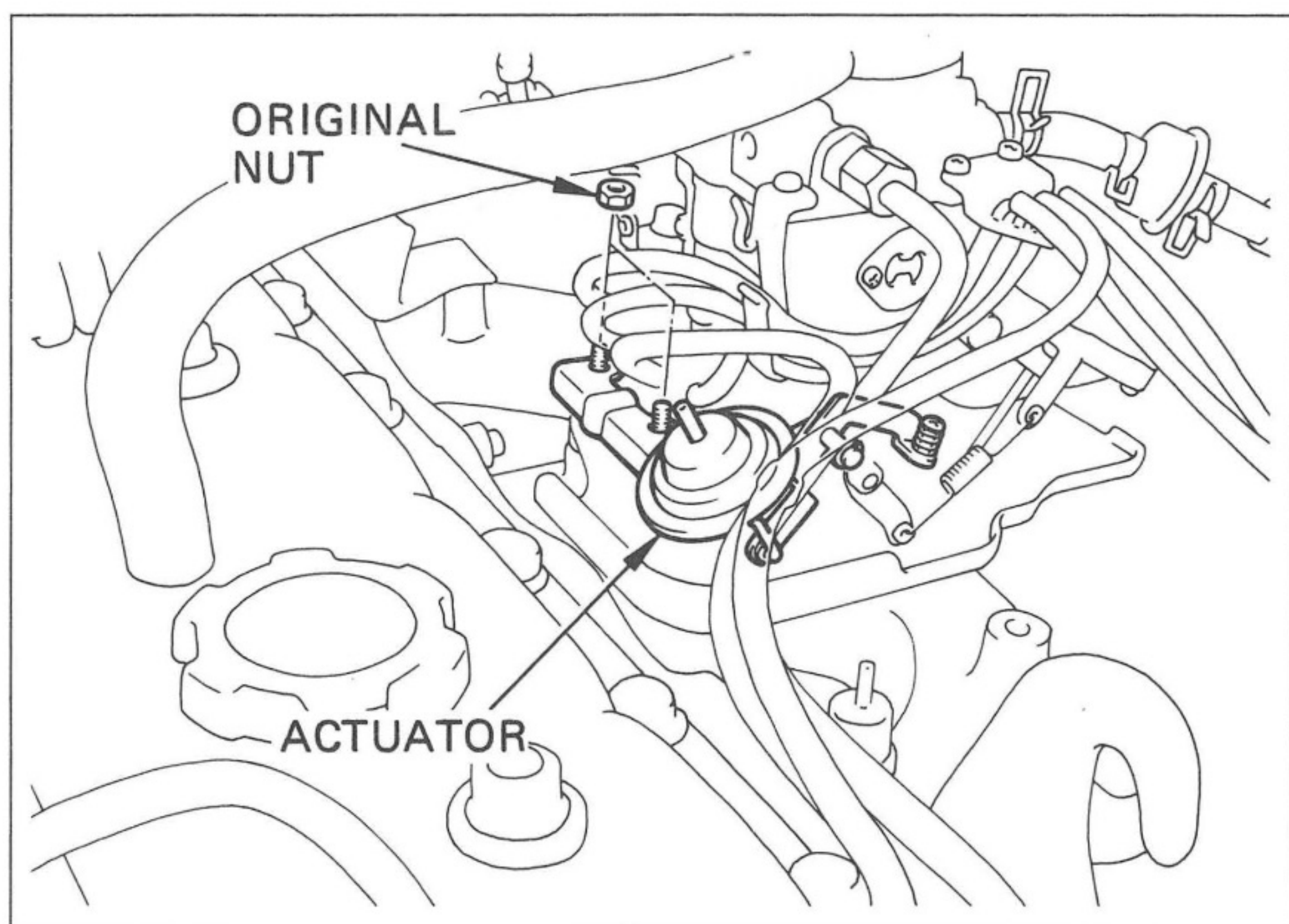

Fig.112

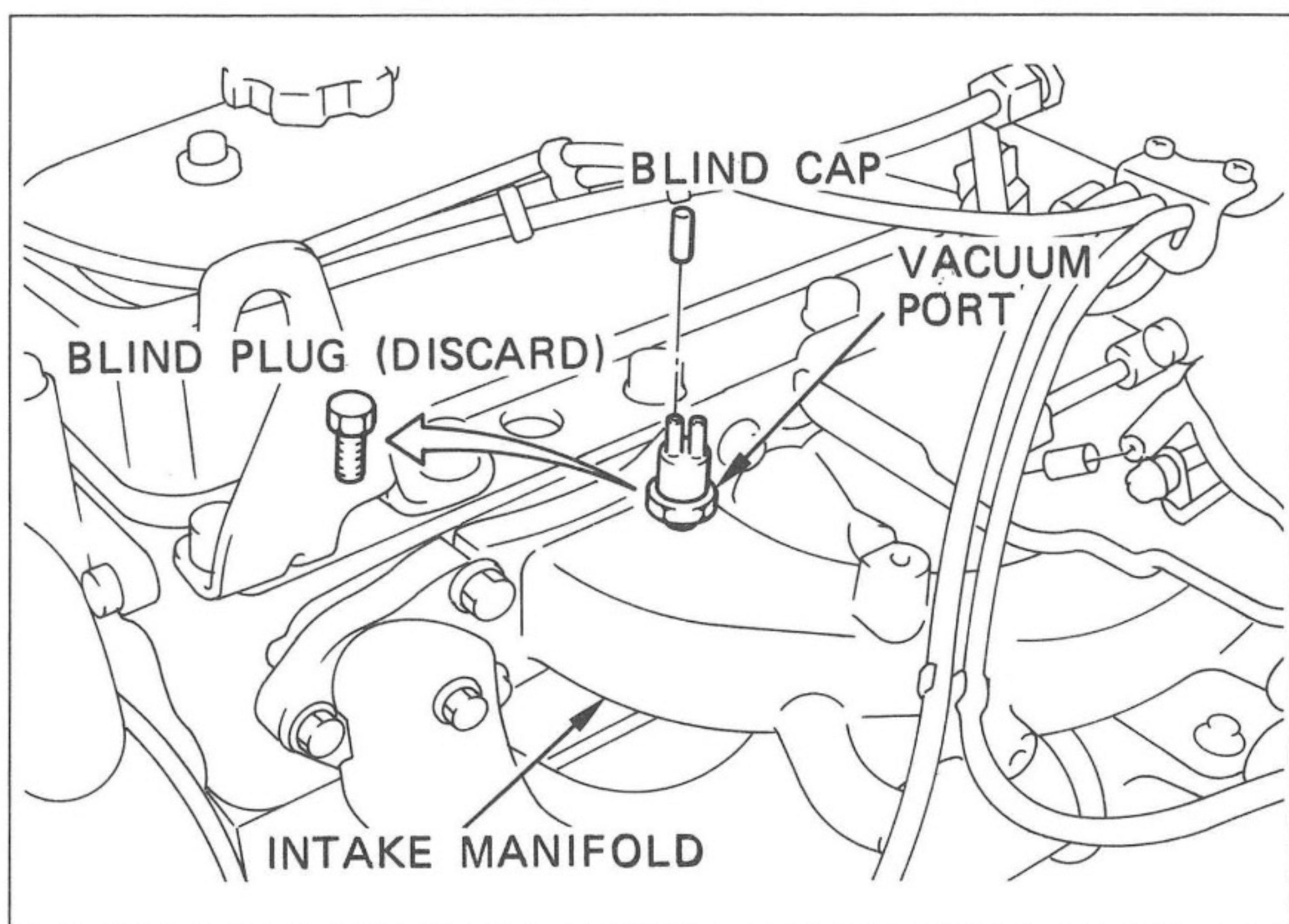

Fig.113

## (10) ENGINE IDLE SPEED CONTROL

### ■ 3F ENGINE MODEL ONLY

#### NOTE

*For vehicles with 3F-E engine the idle up device is already incorporated in the engine management control.*

- (a) Install the VSV together with the relay box using a original bolt.
- (b) Connect the vehicle harness to the VSV.

- (c) Install the actuator to the carburetor using two original nuts.

- (d) Install the vacuum port in place of the blind plug in the intake manifold.

- (e) Install the blind cap supplied in the kit to one of the port of the vacuum port.

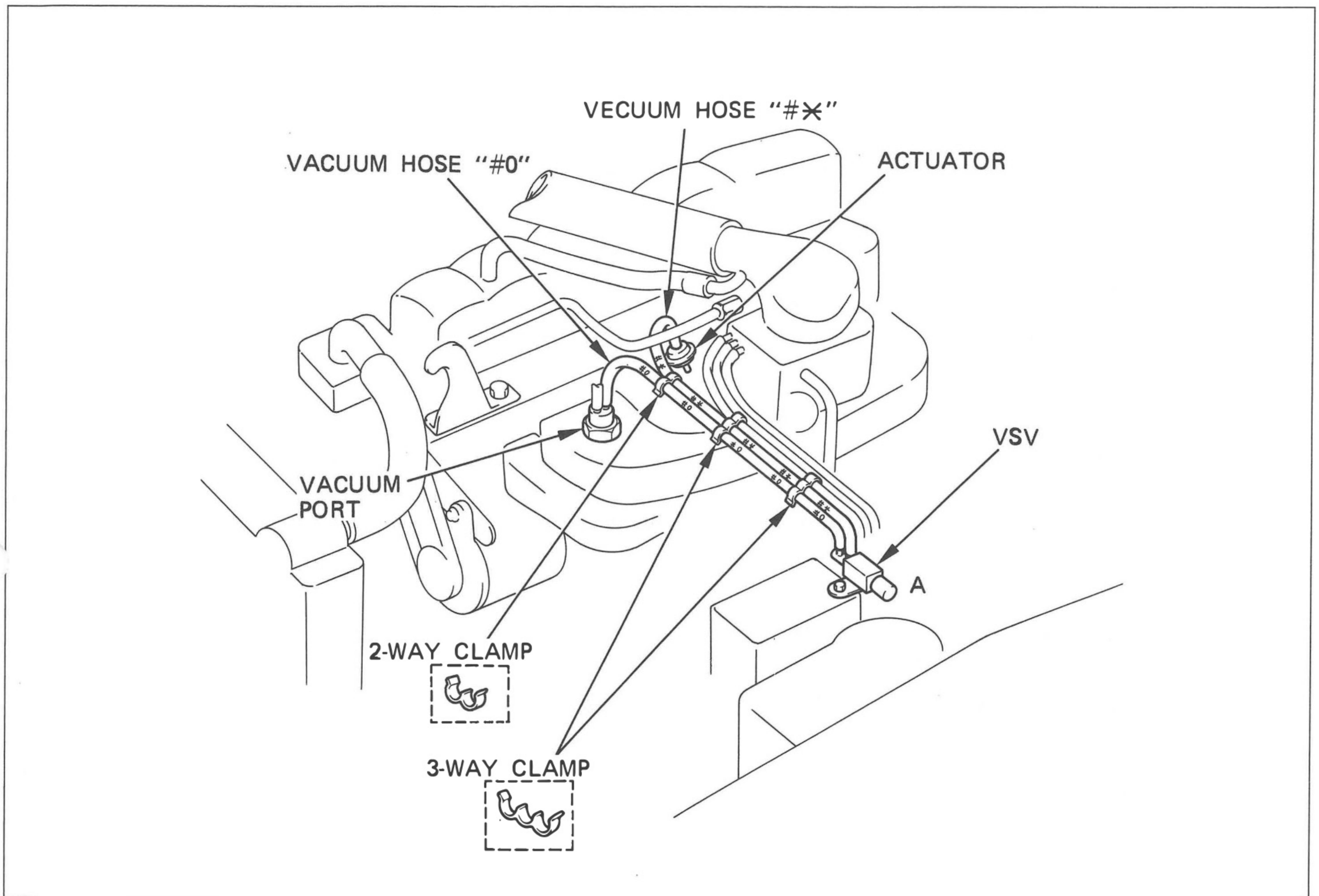

Fig.114

- (f) Connect the vacuum hose "#\*" to the actuator and vacuum hose "#0" to the vacuum port.
- (g) Secure the vacuum hoses using a 2-way clamp and two 3-way clamps as shown.

### (11) BATTERY CARRIER

- (a) Reinstall two batteries and carriers.

**NOTE**

*Make sure the installation side of the battery terminals.*

- (b) Reinstall the earth terminal as shown.

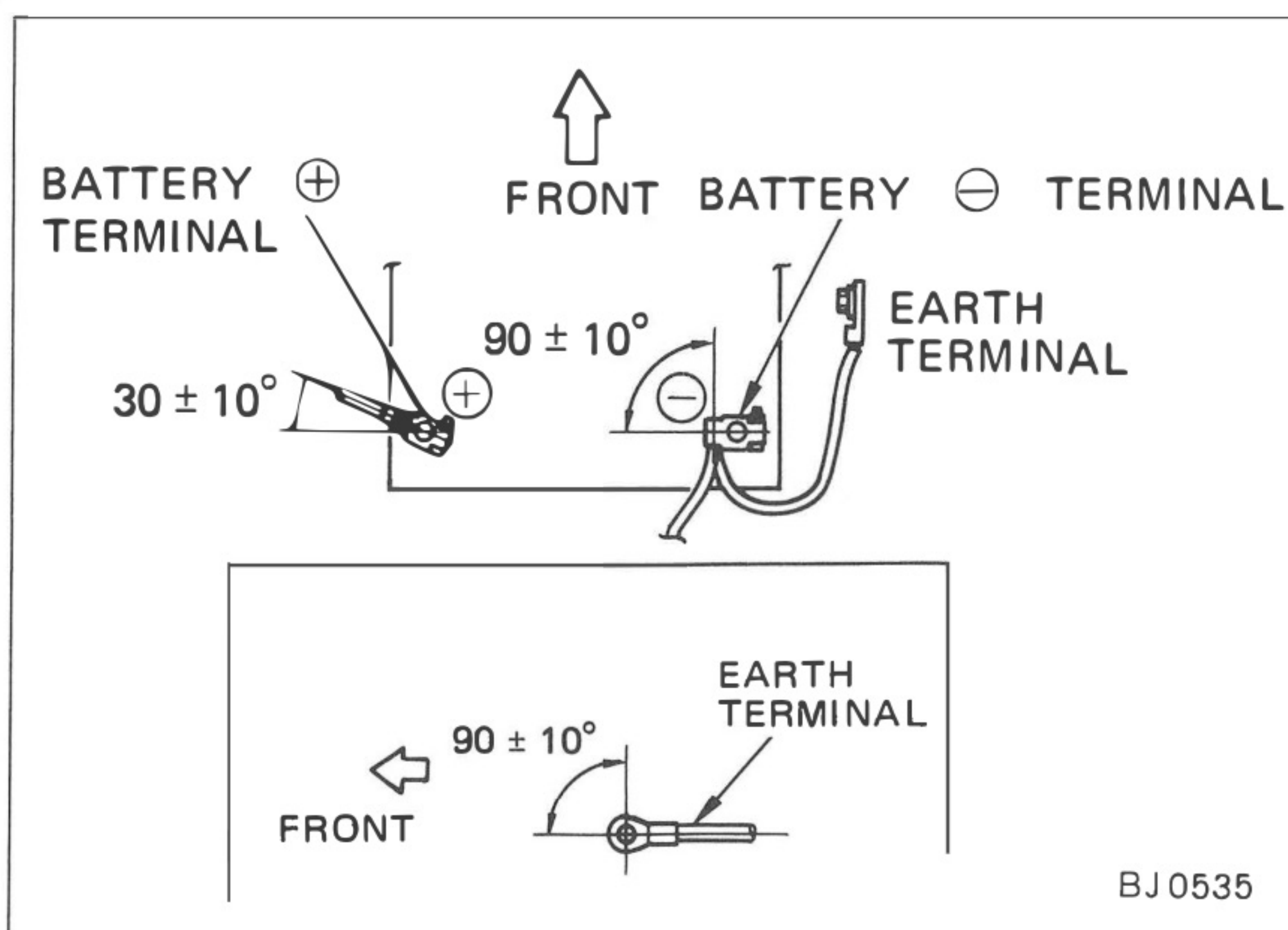

Fig.115

## 2. FINISH

### (1) GENERAL

After air conditioner installation is completed, reinstall the all temporarily removed parts.

### (2) REFRIGERANT CHARGE

Make thorough inspection for gas leakage and various details, and then charge the air conditioning system with refrigerant (Freon R-12) as specified below.

Standard amount of Refrigerant:  $900 \pm 50$  g ( $1.98 \pm 0.11$  lbs)

#### CAUTION

*Never rotate the compressor before charging air conditioning system with refrigerant.*

### (3) ADJUSTMENT OF ENGINE REVOLUTION

The engine idling speed should be adjusted by operating the air conditioner as described below.

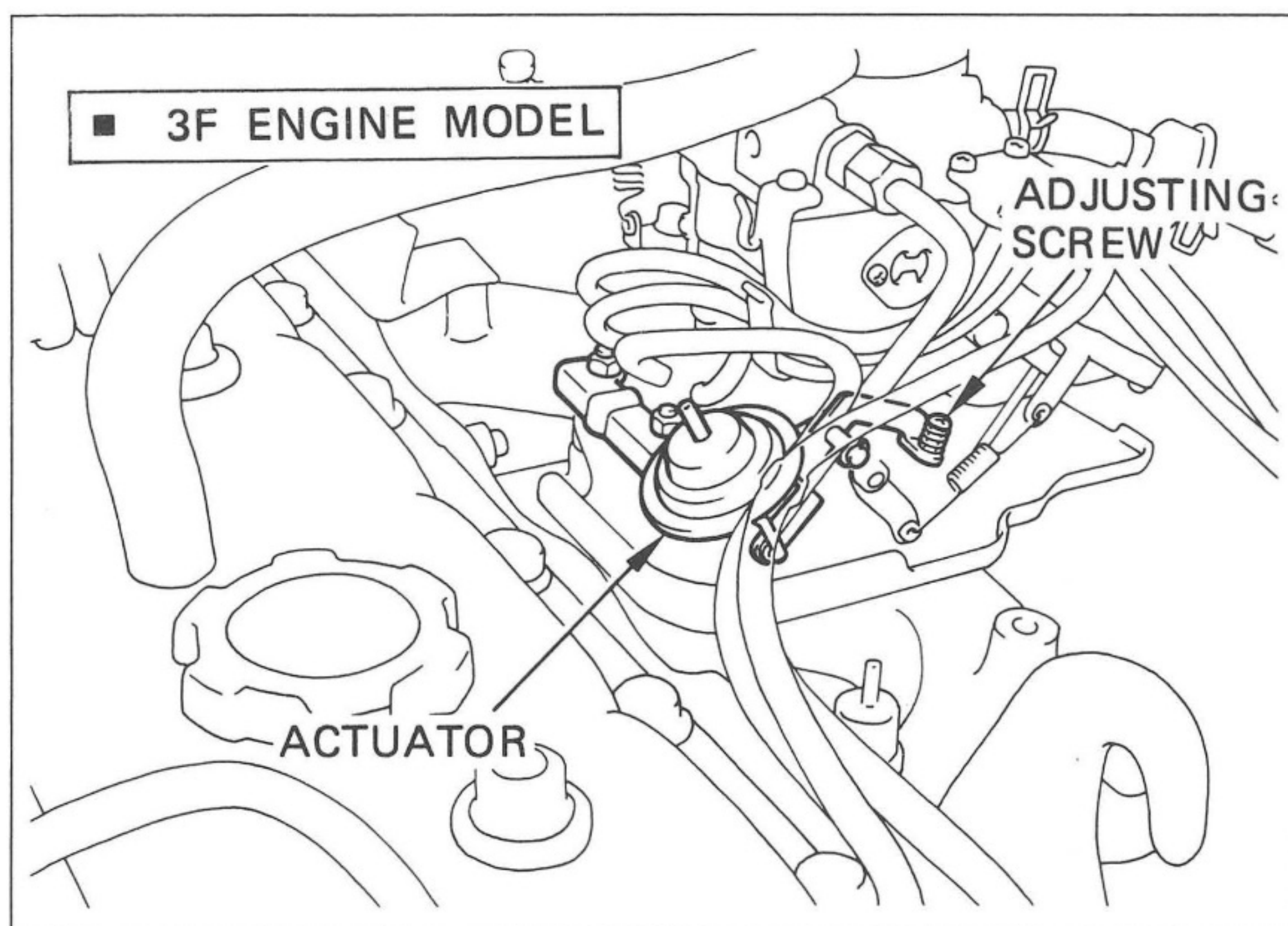

- (a) Start engine and allow it to reach operating temperature before adjusting the idling speed.
- (b) Check the initial ignition timing and initial idling speed.  
Adjust as necessary.
- (c) Place the vehicles in the following conditions.

Mode control .....VENT.  
Temperature control .....MAX COOL  
Blower speed .....HIGH  
Shift lever .....“N” RANGE  
Steering .....STRAIGHT

- (d) Turn the air conditioner on and adjust the engine idling speed.

All Models

Idling speed specification:  
 $950 \pm 50$  rpm

### 1HD-TENGINE MODEL

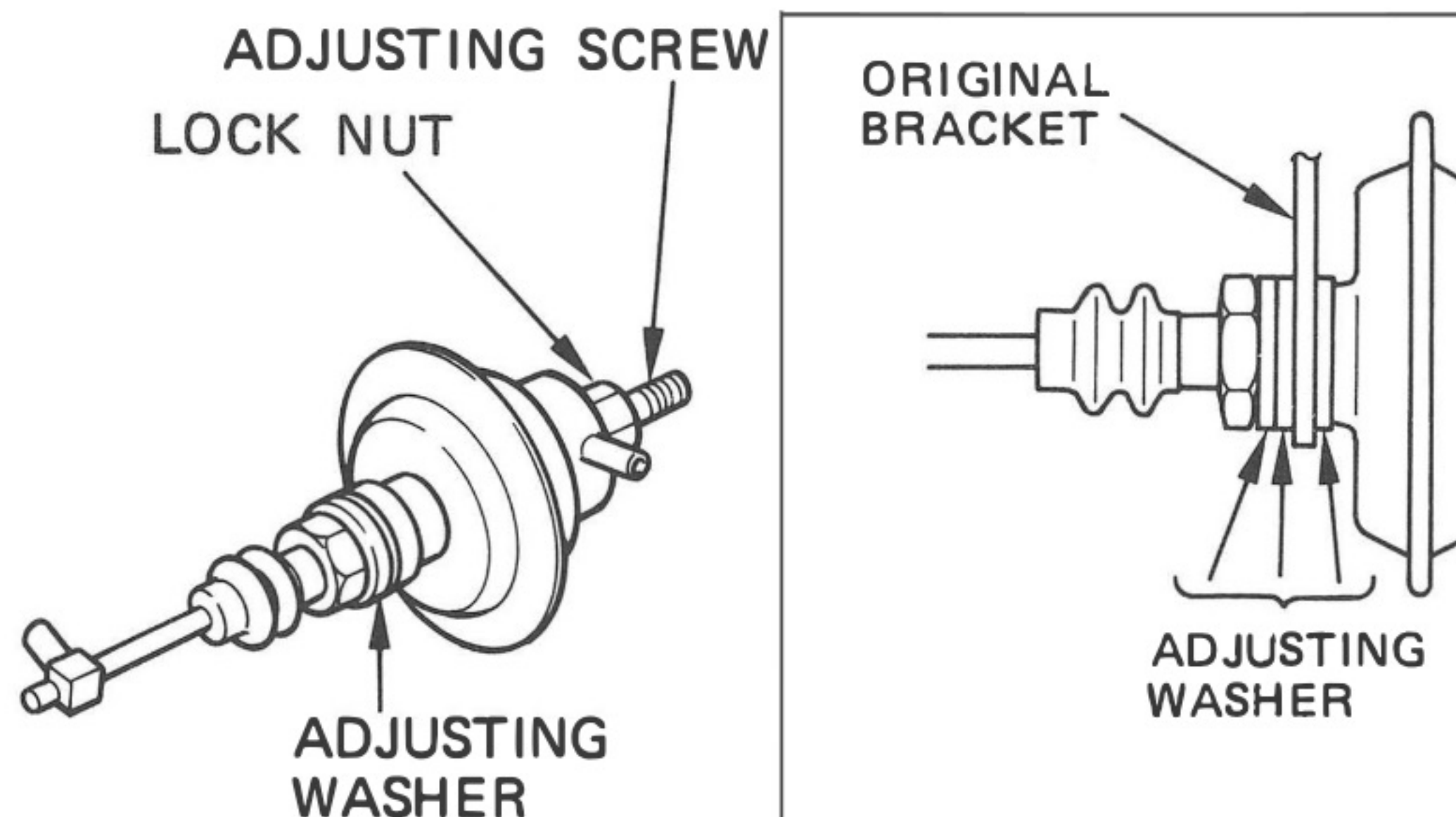

### NOTE

#### ■ 1HD-T ENGINE MODEL

Adjust the engine idle speed by replacing the adjusting washer to the forward or backward of the original bracket and adjust it minutely by turning the adjusting sciew.

After adjusting the engine idle speed control, fasten the adjusting screw by turning the lock nut.

Tightening Torque :  
55 kg-cm (5.4 N-m, 4.0 ft-lbs)

### 1HZ ENGINE MODEL

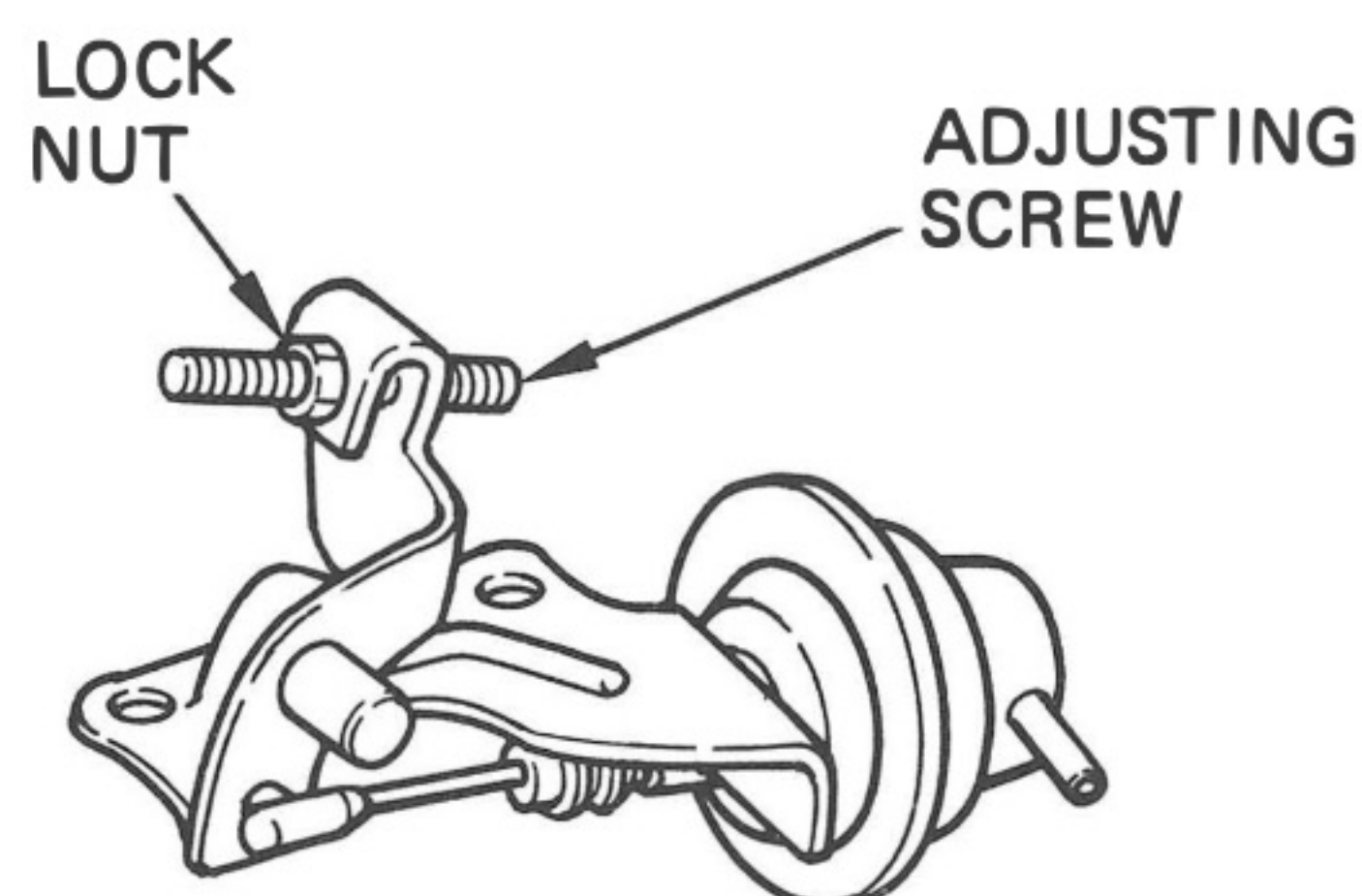

BJ0537

## (4) DRIVE BELT

### CAUTION

- 1) The new compressor drive belt is given extra tension when installed because it will loosen after several minutes running. Recheck that its tension is within the standard specification after operation and performance test. (Five minutes or more operation)
- 2) The belt tension may be measured between any two pulleys in using NIPPONDENSO belt tension gauge. Tension must be adjusted to the middle of standard value.

## (5) FINAL INSPECTION

- (a) Check if
- 1) All heater and air conditioner controls operate correctly.
  - 2) All vehicle functions operate correctly.
  - 3) Any abnormal noises are heard when the air conditioner operating.

Now the air conditioner is ready for use.

Be sure to explain its operation and maintenance schedule to the owner.

### 3. WIRING DIAGRAM

■ 1HZ ENGINE MODEL, 1HD-T ENGINE & A/T MODEL

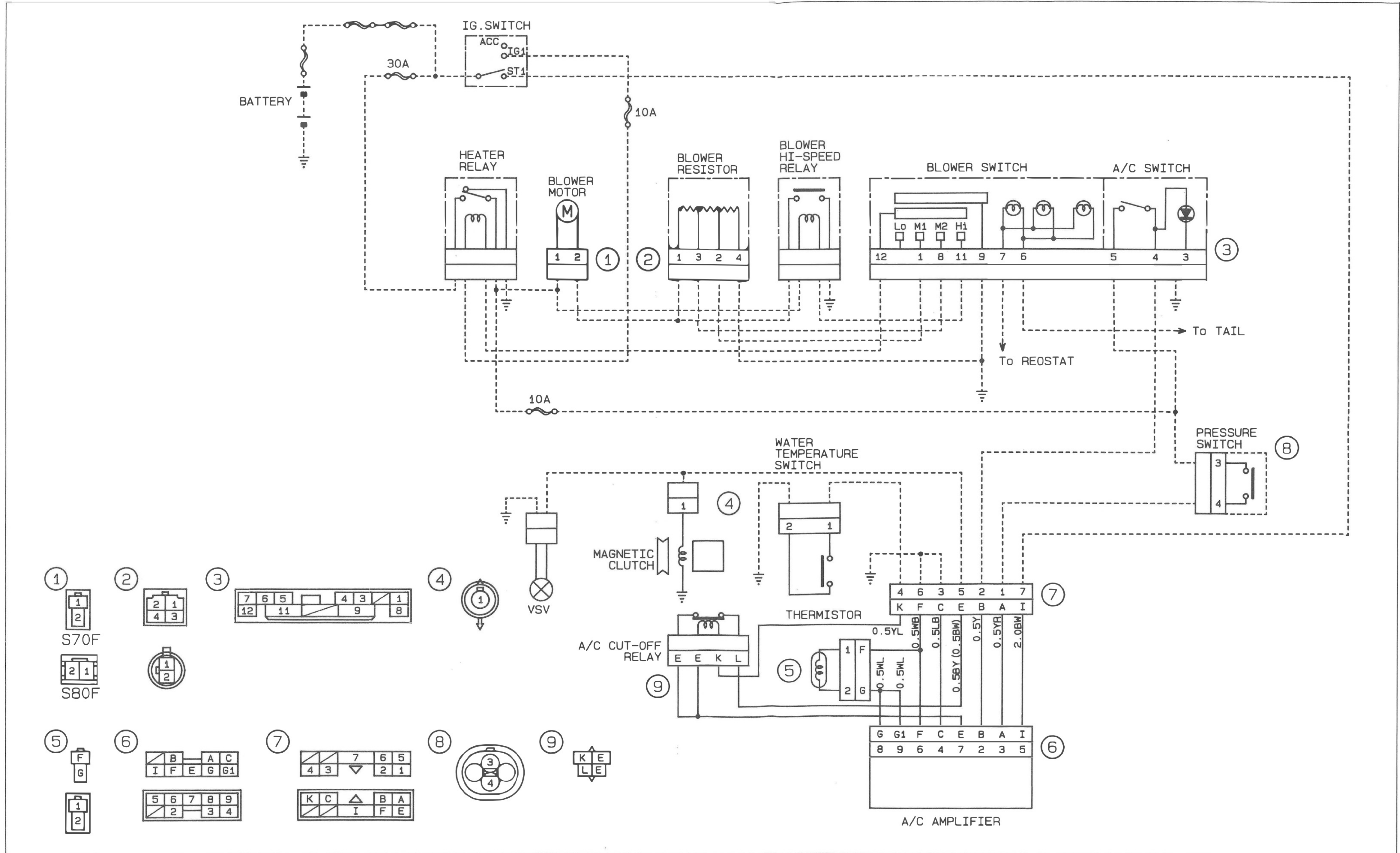

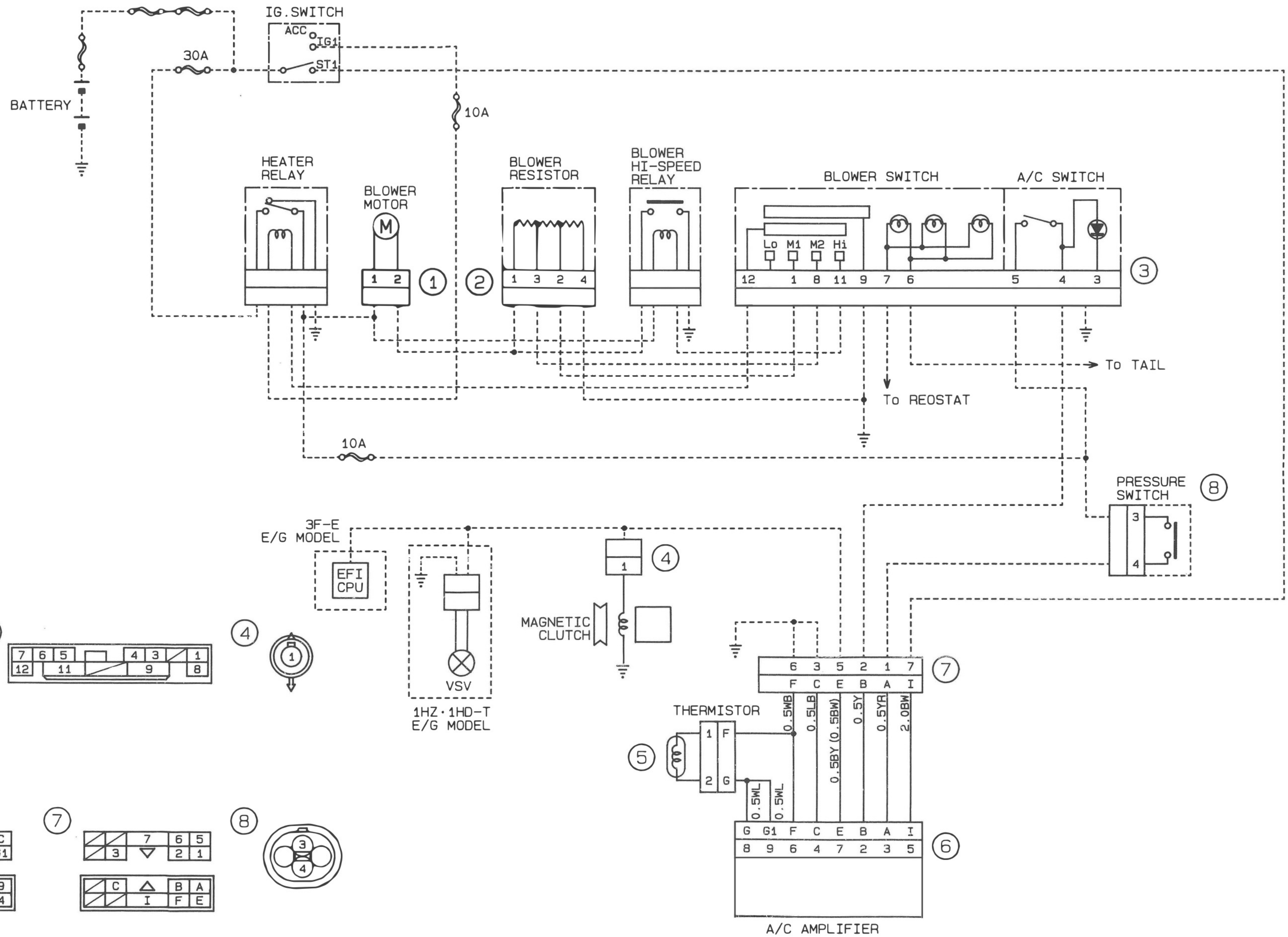

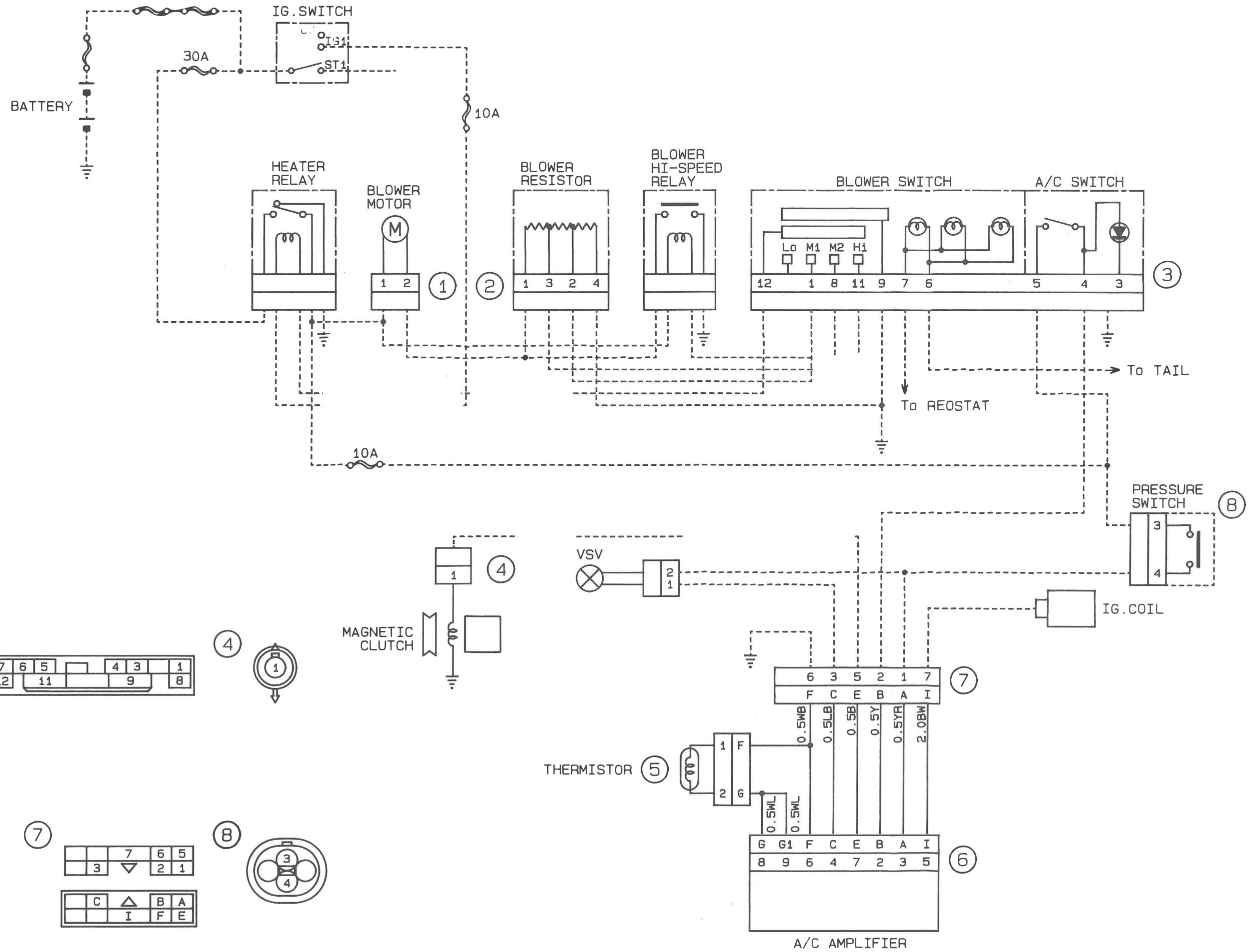

## 4. AMPLIFIER CIRCUIT

■ 1HZ ENGINE MODEL, 1HD-T ENGINE MODEL, 3F-E ENGINE MODEL

