

TOYOTA

1FZ-FE ENGINE

**REPAIR MANUAL FOR
EMISSION CONTROL**

Aug., 1992

FOREWORD

This repair manual has been prepared to provide information covering general service repairs for the Emission Control System of the 1FZ-FE engine.

Applicable models: FZJ70, 75, 80 series.

For service of the 1FZ-FE engine, refer to the following repair manual.

Manual Name	Pub. No.
• 1FZ-F, 1FZ-FE Engine Repair Manual	RM321E

All information in this manual based on the latest product information at the time of publication. However, specifications and procedures are subject to change without notice.

TOYOTA MOTOR CORPORATION

TOYOTA 1FZ-FE ENGINE EMISSION CONTROL REPAIR MANUAL

INTRODUCTION	1
TROUBLESHOOTING	2
EMISSION CONTROL SYSTEMS	3
ENGINE ADJUSTMENT	4
SIMPLE CHECK METHOD	5
SPECIFICATIONS	A

INTRODUCTION

GENERAL PRECAUTIONS 1-2
PRECAUTIONS FOR VEHICLES EQUIPPED
WITH A CATALYTIC CONVERTER 1-3
ABBREVIATIONS USED IN THIS MANUAL ... 1-4

GENERAL PRECAUTIONS

1. **Know the importance of periodic maintenance.**
 - (a) Every service item in the periodic maintenance list must be performed.
 - (b) Failing to do even one item can cause the engine to run poorly and increase exhaust emissions.

2. **Listen to the customers comments carefully.**

Always determine exactly what the customer's complaint is, if any, and verify it before proceeding with repairs.

3. **Determine if you have an engine or emission system problem.**

- (a) Engine problems are usually not caused by the emission control systems.
- (b) When troubleshooting, always check the engine and the ignition system first.

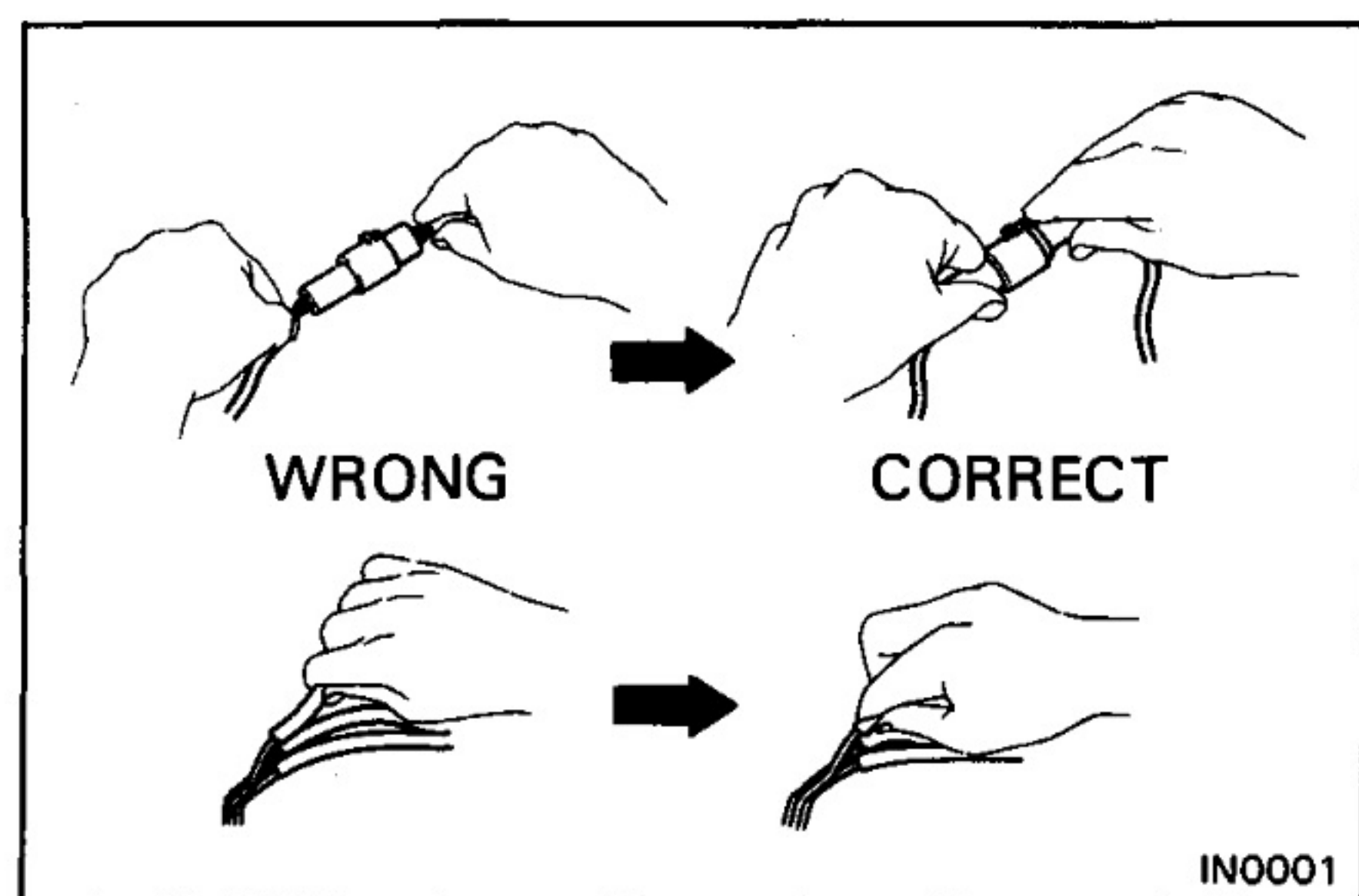

4. **Check hose and wiring connections first.**

The most frequent cause of problems is simply a bad wiring or vacuum hose connection. Always make sure that all connections are secure and correct.

5. **Observe the following precautions to avoid damage to the parts:**

- (a) Do not open the cover or the case of the ECU unless absolutely necessary. (If the IC terminals are touched, the IC may be destroyed by static electricity.)
- (b) To disconnect vacuum hoses, pull on the end, not the middle of the hose.
- (c) To pull apart electrical connectors, pull on the connector itself, not the wires.
- (d) Be careful not to drop electrical components, such as sensors or relays. If they are dropped on a hard floor, they should be replaced and not reused.
- (e) When steam cleaning an engine, protect the distributor, air filter, intake, and EGR vacuum modulator from water.
- (f) Never use an impact wrench to remove or install thermo switches or thermo sensors.
- (g) When checking continuity at a wire connector, insert the tester probe carefully to prevent bending the terminals.
- (h) When using a vacuum gauge, never force the hose onto a connector that is too large. Use a step-down adapter instead. Once the hose has been stretched, it may leak.

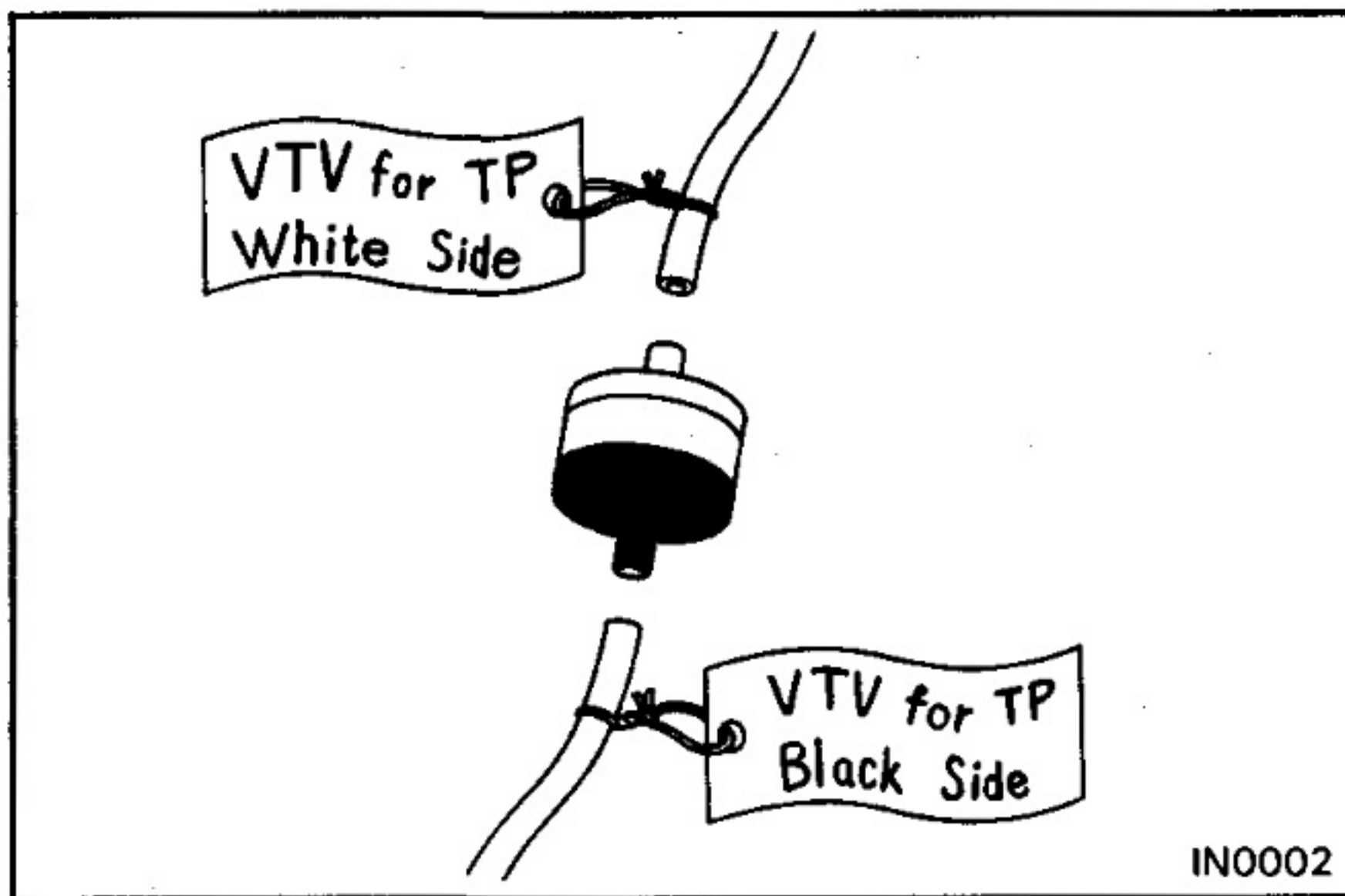

6. Tag hoses before disconnecting them:

- (a) When disconnecting vacuum hoses, use tags to identify how they should be reconnected.
- (b) After completing a job, double check that the vacuum hoses are properly connected. A label under the hood shows the proper layout.

7. Use genuine parts.

8. Perform work safely.

- (a) If the vehicle is to be jacked up only at the front or rear end, be sure to block the wheels.
- (b) After the vehicle is jacked up, do not fail to support it on stands. It is extremely dangerous to do any work on the vehicle raised on a jack alone, even for a small job that can be finished quickly.
- (c) Disconnect the battery cable from the negative (—) terminal of the battery to make work safer when replacing electrical parts or working on parts near an electrical source.

PRECAUTIONS FOR VEHICLES EQUIPPED WITH A CATALYTIC CONVERTER

CAUTION: If large amounts of unburnt gasoline flow into the catalytic converter, it may overheat and create a fire hazard. To prevent this, observe the following precautions and explain them to your customer.

1. Use only unleaded gasoline.

2. Avoid prolonged idling.

Avoid running the engine at fast idle speed for more than 10 minutes and at idle speed for more than 20 minutes.

3. Avoid spark jump test.

- (a) Perform spark jump test only when absolutely necessary and as quickly as possible.
- (b) Never race the engine while testing.

4. Avoid prolonged engine compression measurement.

Engine compression tests must be make as quickly as possible.

5. Do not run engine when fuel tank is nearly empty.

This may cause the engine to misfire and create an extra load on the catalytic converter.

6. Avoid coating with ignition turned off and prolonged engine braking.

7. Do not dispose of used catalytic converter along with parts contaminated gasoline or oil.

ABBREVIATIONS USED IN THIS MANUAL

AS	Air Suction
A/T	Automatic Transmission
BTDC	Before Top Dead Center
BVSV	Bimetal Vacuum Switching Valve
ECU	Electronic Control Unit
EFI	Electronic Fuel Injection
EGR	Exhaust Gas Recirculation
EVAP	Fuel Evaporative Emission Control
IG	Ignition
M/T	Manual Transmission
PCV	Positive Crankcase Ventilation
SST	Special Service Tool
TWC	Three-way Catalyst
VCV	Vacuum Control Valve
VSV	Vacuum Switching Valve
w/	With
w/o	Without

TROUBLESHOOTING

ENGINE OVERHEATING	2-2
HARD STARTING	2-2
ROUGH IDLING	2-2
ENGINE HESITATES/POOR ACCELERATION	2-3
ENGINE DIESELING	2-4
AFTER FIRE, BACKFIRE	2-4
EXCESSIVE OIL CONSUMPTION	2-4
EXCESSIVE FUEL CONSUMPTION	2-5
UNPLEASANT ODOR	2-5

ENGINE OVERHEATING

Problem	Possible cause	Remedy
Engine overheats	Cooling system faulty Incorrect ignition timing	Troubleshoot cooling system Reset timing

HARD STARTING

Problem	Possible cause	Remedy
Engine will not crank or cranks slowly	Starting system faulty	Troubleshoot starting system
Engine will not start/ hard to start (cranks OK)	No fuel supply to injector <ul style="list-style-type: none"> • No fuel in tank • Fuel pump not working • Fuel filter clogged • Fuel line clogged or leaking EFI system problems Ignition problems <ul style="list-style-type: none"> • Ignition coil • Igniter • Distributor Spark plugs faulty High-tension cords disconnected or broken Vacuum leaks <ul style="list-style-type: none"> • PCV line • EGR line • Intake manifold • Air intake chamber • Throttle body • ISC valve • Brake booster line Pulling in air between air flow meter and throttle body Low compression	Troubleshoot EFI system Repair as necessary Perform spark test Inspect plugs Inspect cords Repair as necessary Repair as necessary Check compression

ROUGH IDLING

Problem	Possible cause	Remedy
Rough idle, stalls or misses	Spark plugs faulty High-tension cords faulty Ignition problems <ul style="list-style-type: none"> • Ignition coil • Igniter • Distributor Incorrect ignition timing Vacuum leaks <ul style="list-style-type: none"> • PCV line • EGR line • Intake manifold • Air intake chamber 	Inspect plugs Inspect cords Inspect coil Inspect igniter Inspect distributor Reset timing Repair as necessary

ROUGH IDLING (Cont'd)

Problem	Possible cause	Remedy
Rough idle, stalls or misses (Cont'd)	<ul style="list-style-type: none"> • Throttle body • ISC valve • Brake booster line Pulling in air between air flow meter and throttle body Incorrect idle speed Incorrect valve clearance EFI system problems Engine overheats Low compression	Check ISC system Adjust valve clearance Repair as necessary Check cooling system Check compression

ENGINE HESITATES/POOR ACCELERATION

Problem	Possible cause	Remedy
Engine hesitates/ poor acceleration	Spark plugs faulty High-tension cords faulty Vacuum leaks <ul style="list-style-type: none"> • PCV line • EGR line • Intake manifold • Air intake chamber • Throttle body • ISC valve • Brake booster line Pulling in air between air flow meter and throttle body Incorrect ignition timing Incorrect valve clearance Fuel system clogged Air cleaner clogged EFI system problems Emission control system problem (cold engine) <ul style="list-style-type: none"> • EGR system always on Engine overheats Low compression	Inspect plugs Inspect cords Repair as necessary Repair as necessary Reset timing Adjust valve clearance Check fuel system Check air cleaner Repair as necessary Check EGR system Check cooling system Check compression

ENGINE DIESELING

Problem	Possible cause	Remedy
Engine diesels (run after ignition switch turned off)	EFI system problems	Repair as necessary

AFTER FIRE, BACKFIRE

Problem	Possible cause	Remedy
Muffler explosion (after fire on deceleration only)	Deceleration fuel cut system always off	Check EFI (fuel cut) system
Muffler explosion (after fire) all the time	Air cleaner clogged EFI system problems Incorrect ignition timing	Check air cleaner Repair as necessary Reset timing
Engine backfires	EFI system problems Vacuum leak <ul style="list-style-type: none"> • PCV line • EGR line • Intake manifold • Air intake chamber • Throttle body • ISC valve • Brake booster line Pulling in air between air flow meter and throttle body Insufficient fuel flow Incorrect ignition timing Incorrect valve clearance Carbon deposits in combustion chambers	Repair as necessary Check hoses and repair as necessary Repair as necessary Troubleshoot fuel system Reset timing Adjust valve clearance Inspect cylinder head

EXCESSIVE OIL CONSUMPTION

Problem	Possible cause	Remedy
Excessive oil consumption	Oil leak PCV line clogged Piston rings worn or damaged Valve stem and guide worn Valve stem seal worn	Repair as necessary Check PCV system Check rings Check valves and guide bushing Check seals

EXCESSIVE FUEL CONSUMPTION

Problem	Possible cause	Remedy
Excessive fuel consumption	Fuel leak Air cleaner clogged Incorrect ignition timing EFI system problems <ul style="list-style-type: none"> • Injector faulty • Deceleration fuel cut system faulty Idle speed too high Spark plugs faulty EGR system always on Low compression Tires improperly inflated Brakes drag	Repair as necessary Check air cleaner Reset timing Reset timing Check ISC system Inspect plugs Check EGR system Check compression Inflate tires to proper pressure Troubleshoot brakes

UNPLEASANT ODOR

Problem	Possible cause	Remedy
Unpleasant odor	Incorrect idle speed Incorrect ignition timing Vacuum leaks <ul style="list-style-type: none"> • PCV line • EGR line • Intake manifold • Air intake chamber • Throttle body • ISC valve • Brake booster line EFI system problems	Check ISC system Reset timing Repair as necessary Repair as necessary

EMISSION CONTROL SYSTEMS

SYSTEM PURPOSE	3-2
COMPONENT LAYOUT AND SCHEMATIC DRAWING	3-3
POSITIVE CRANKCASE VENTILATION (PCV) SYSTEM	3-5
FUEL EVAPORATIVE EMISSION CONTROL (EVAP) SYSTEM	3-7
EXHAUST GAS RECIRCULATION (EGR) SYSTEM	3-15
AIR SUCTION (AS) SYSTEM	3-22
THREE-WAY CATALYTIC CONVERTER (TWC) SYSTEM	3-28

SYSTEM PURPOSE

System	Abbreviation	Purpose	Application
Positive crankcase ventilation	PCV	Reduces blow-by gas (HC)	ALL
Evaporative emission control	EVAP	Reduces evaporative HC	(ex. General)
Exhaust gas recirculation	EGR	Reduces NOx	Europe
Air suction	AS	Reduces CO and HC	Europe
Three-way catalytic converter	TWC	Reduces CO, HC and NOx	Europe
Electronic fuel injection*	EFI	Regulates all engine conditions for reduction of exhaust emissions.	—

*For inspection and repair of the EFI system, refer to the EFI section of 1FZ-F, 1FZ-FE Repair Manual. (Pub-No. RM321E).

COMPONENT LAYOUT AND SCHEMATIC DRAWING (Europe)

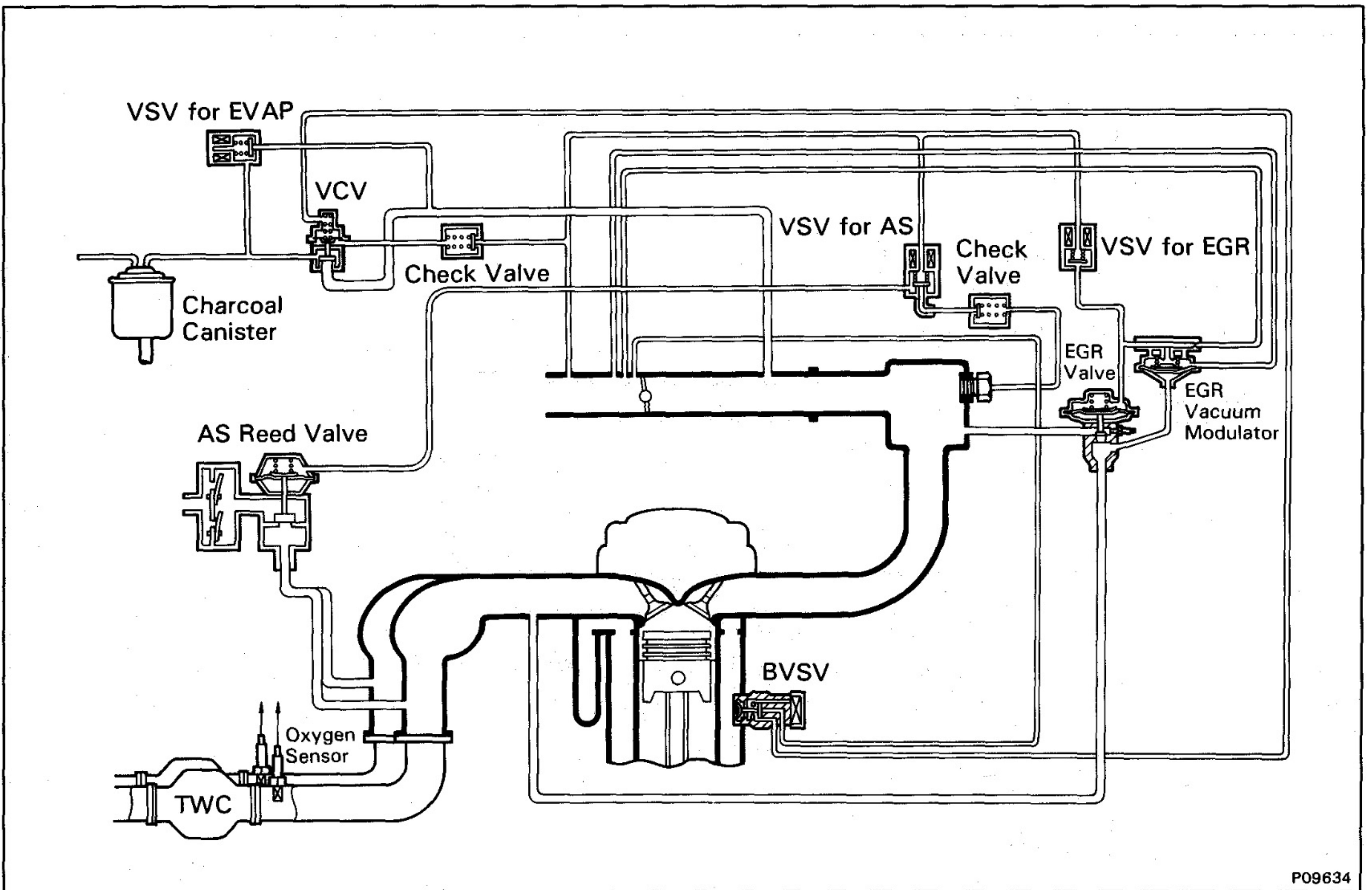
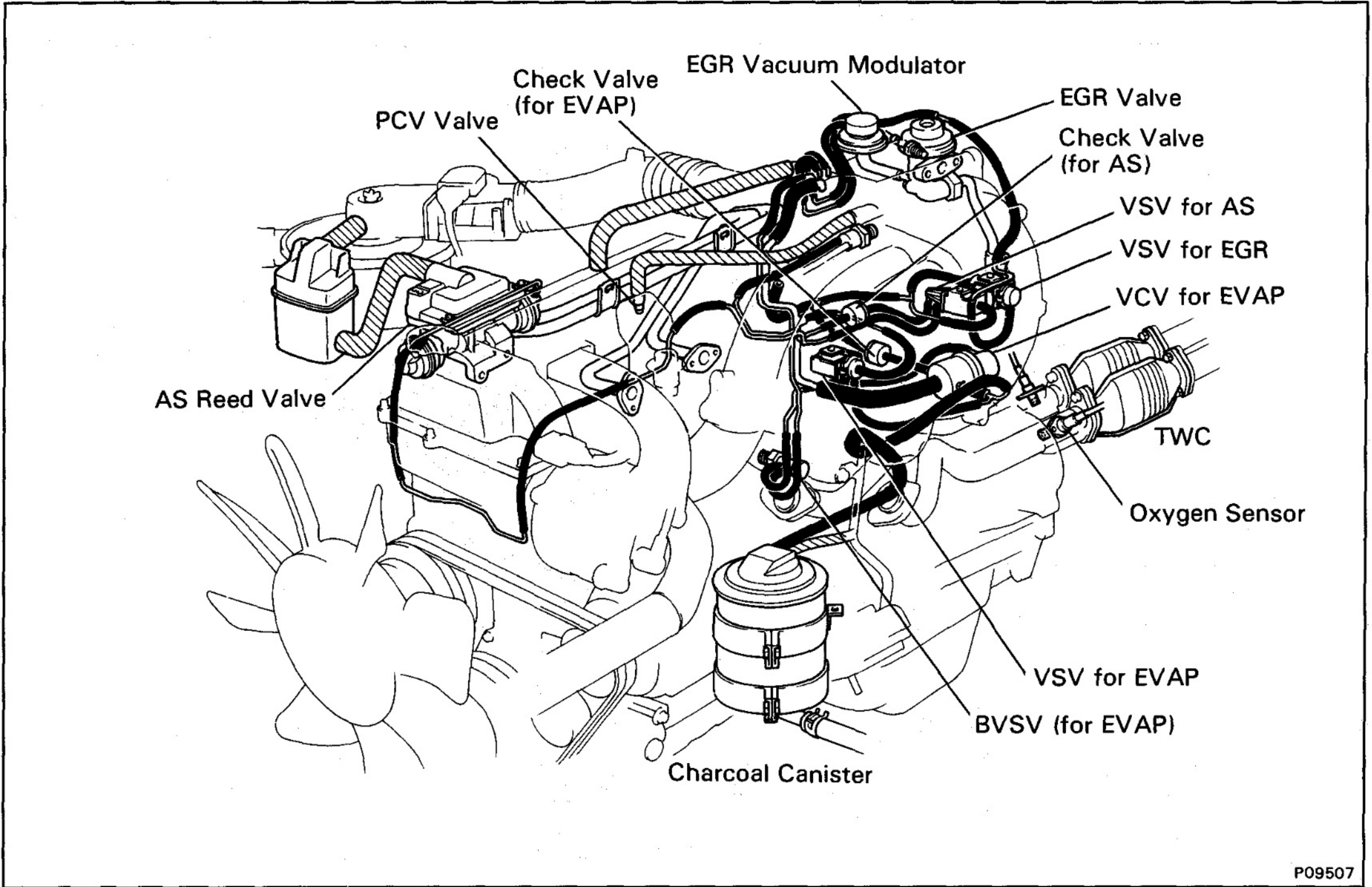

COMPONENT LAYOUT AND SCHEMATIC DRAWING (Ex. Europe)

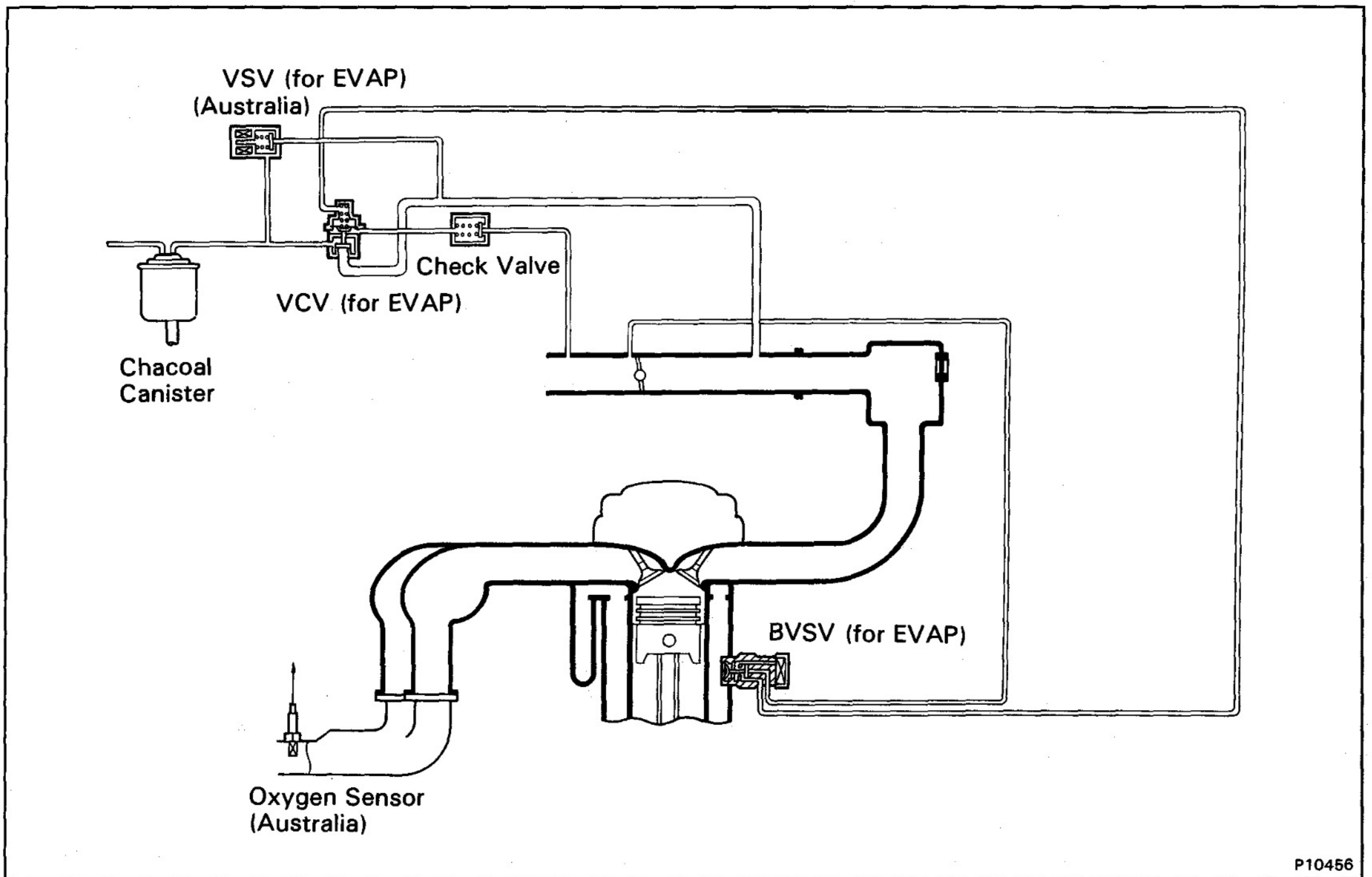
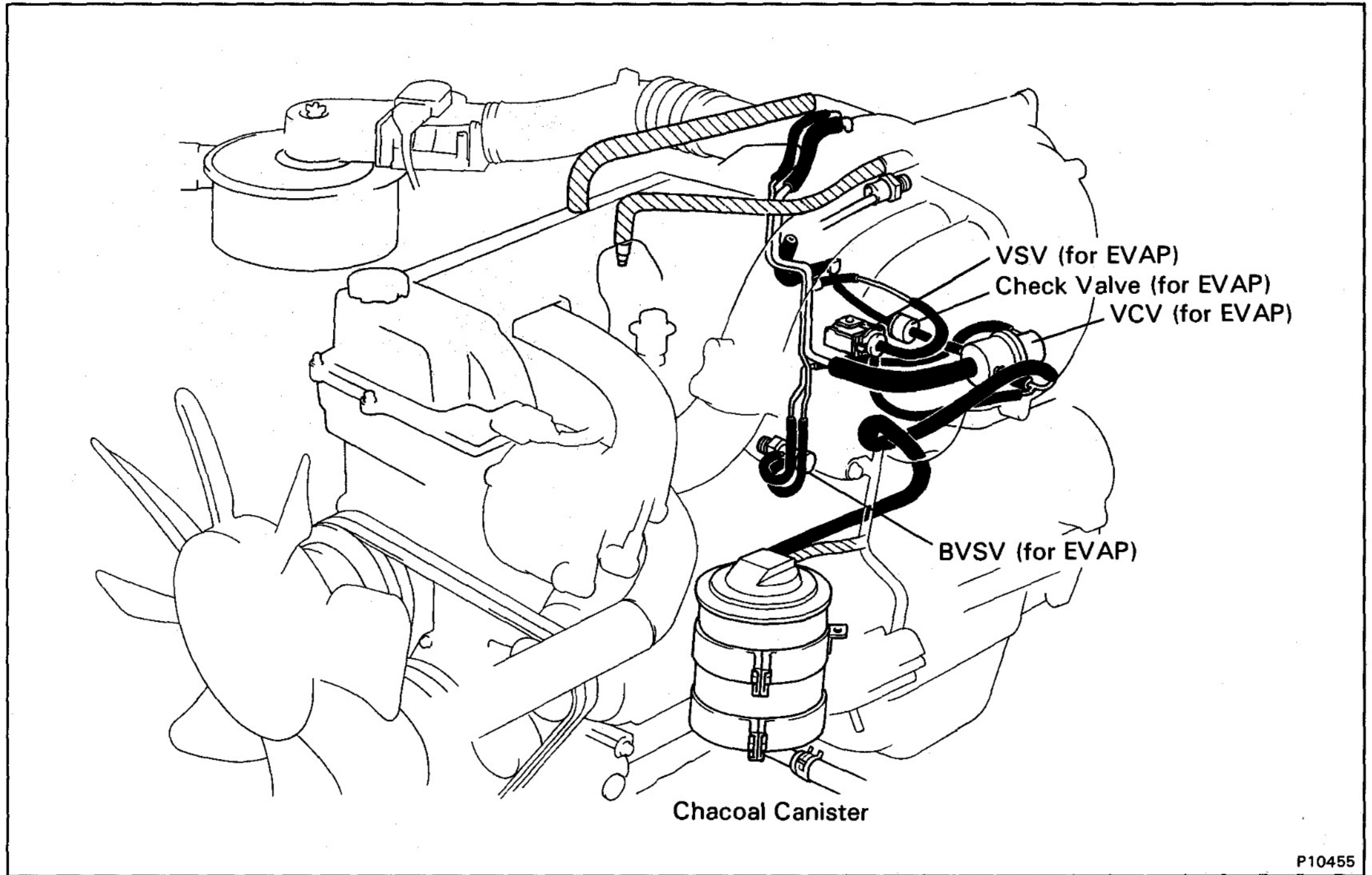

POSITIVE CRANKCASE VENTILATION (PCV) SYSTEM

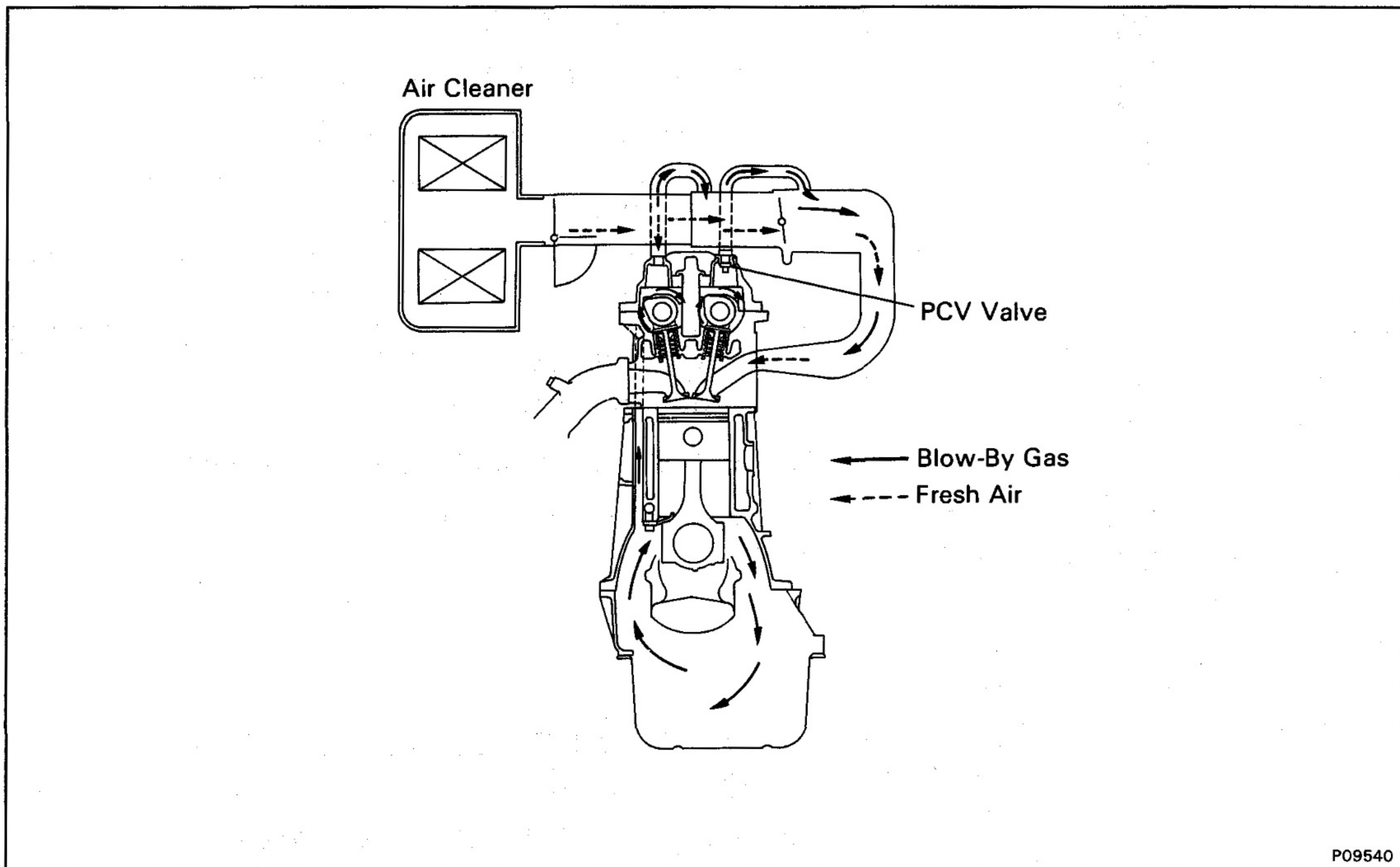

P09540

To reduce HC emission, crankcase blow-by gas (HC) is routed through the PCV valve to the intake manifold for combustion in the cylinders.

Engine not Running or Backfiring
Air Intake Chamber Side

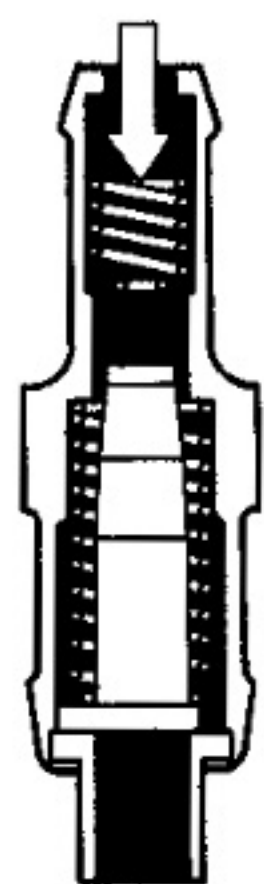

- PCV VALVE IS CLOSED.

Cylinder Head Cover Side

P05450

Normal Operation

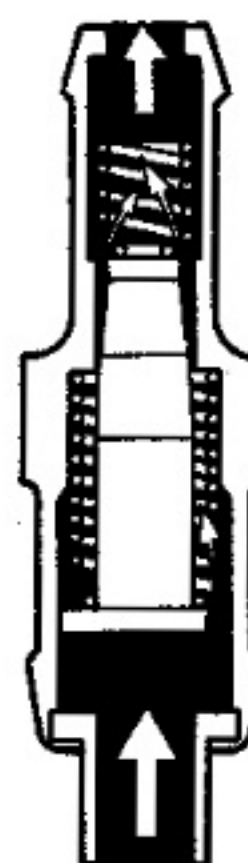

- PCV VALVE IS OPEN.
- VACUUM PASSAGE IS SMALL.

P05452

Idling or Decelerating

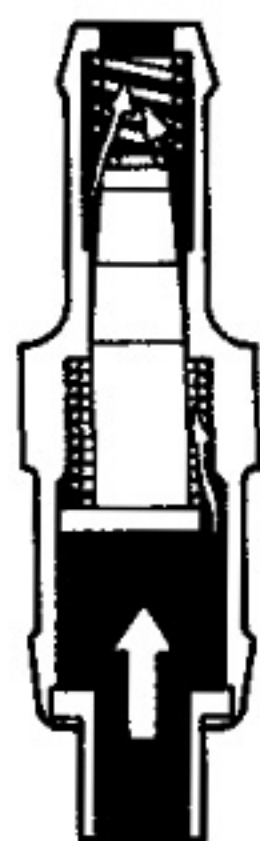

- PCV VALVE IS OPEN.
- VACUUM PASSAGE IS LARGE.

P05451

Acceleration or High Load



- PCV VALVE IS FULLY OPEN.

P05453

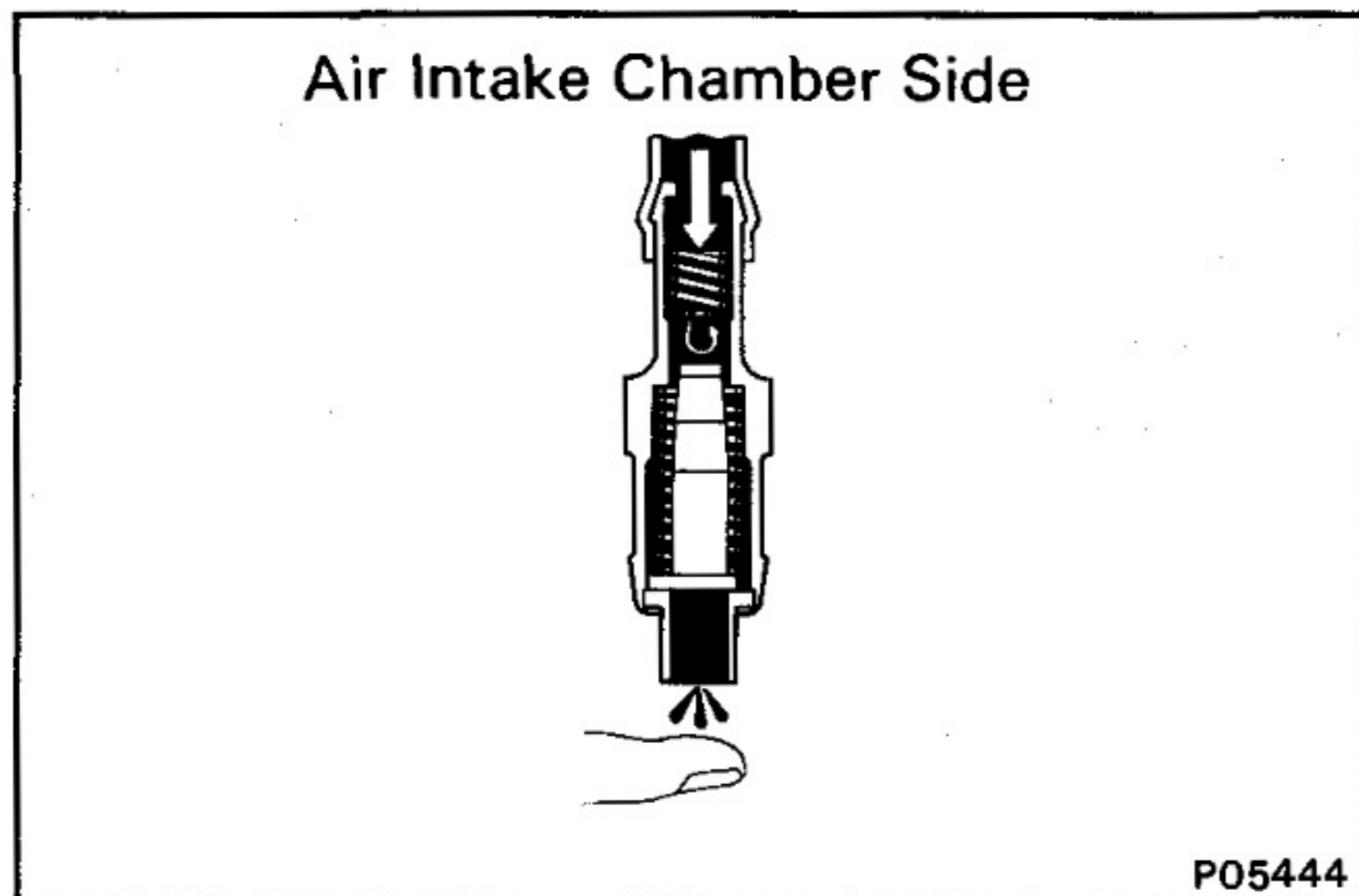
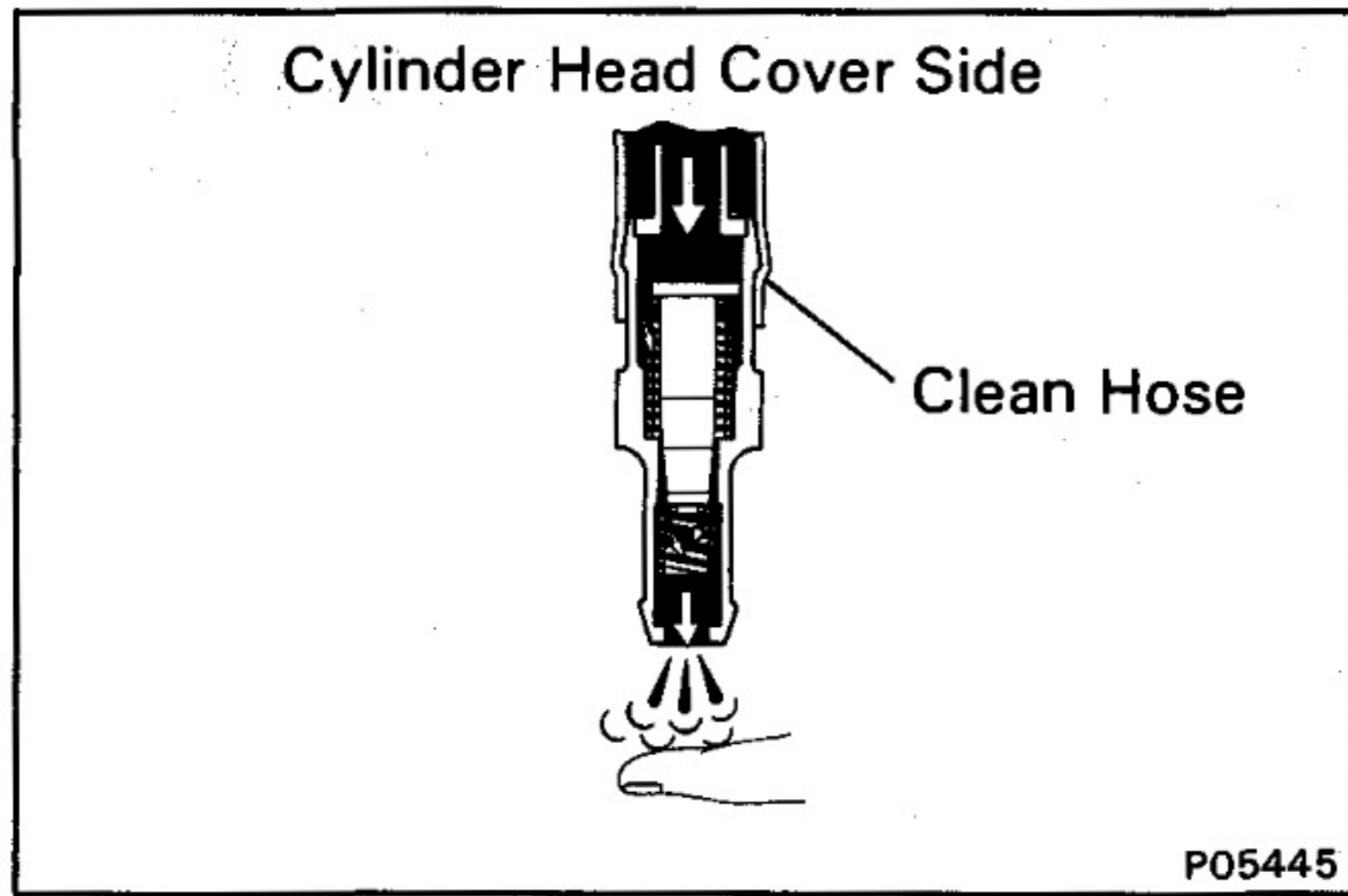

INSPECTION OF PCV VALVE

1. REMOVE PCV VALVE
2. INSTALL CLEAN HOSE TO PCV VALVE
3. INSPECT PCV VALVE OPERATION
 - (a) Blow into the cylinder head cover side, and check that air passes through easily.

CAUTION: Do not suck air through the valve. Petroleum substances inside the valve are harmful.

 - (b) Blow air into the air intake chamber side, and check that air passes through with difficulty.

If operation is not as specified, replace the PCV valve.

4. REMOVE CLEAN HOSE FROM PCV VALVE
5. REINSTALL PCV VALVE

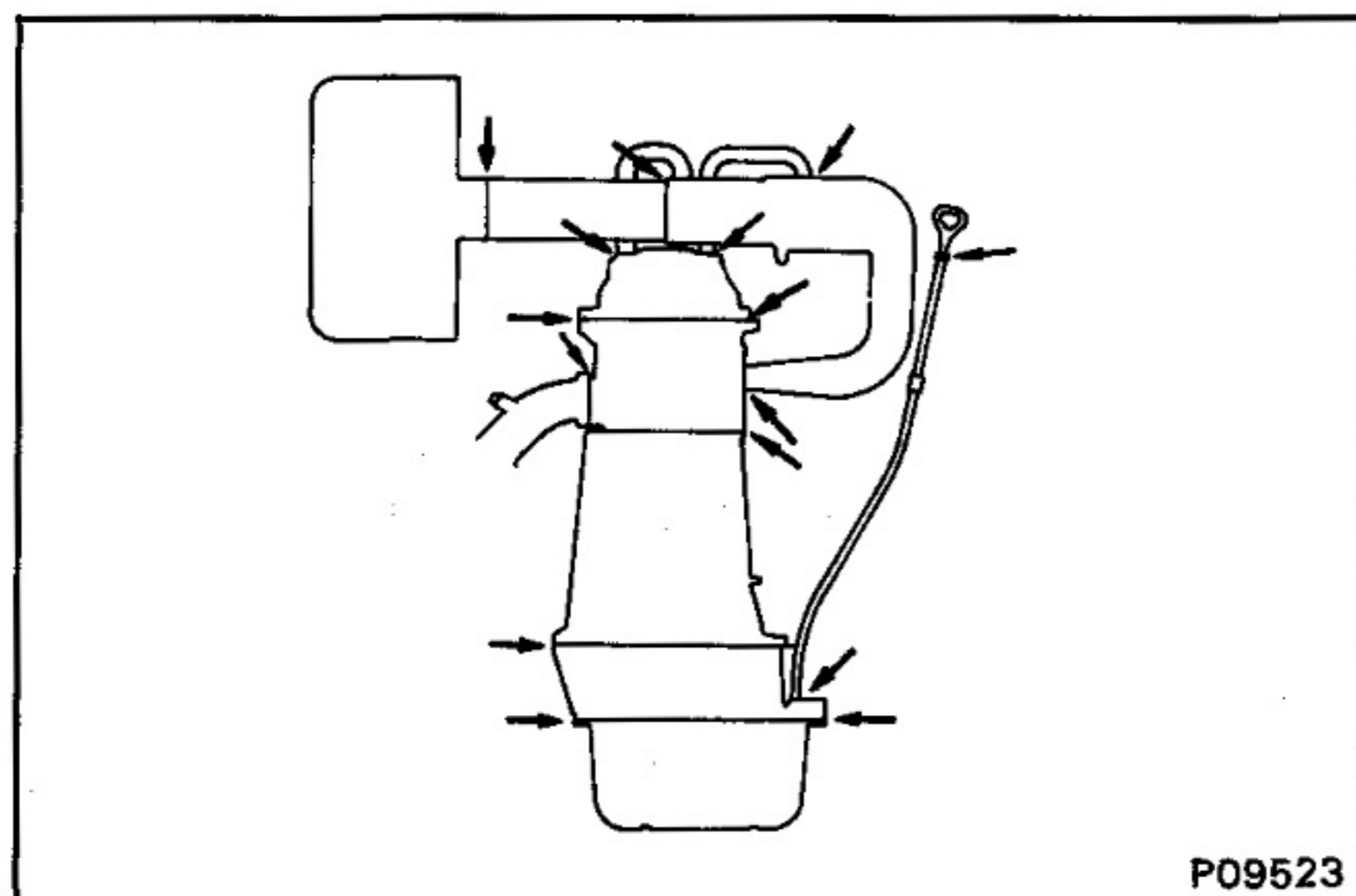

INSPECTION OF PCV HOSES AND CONNECTIONS

VISUALLY INSPECT HOSES AND CONNECTIONS

Check for cracks, leaks or damage.

FUEL EVAPORATIVE EMISSION (EVAP) CONTROL SYSTEM

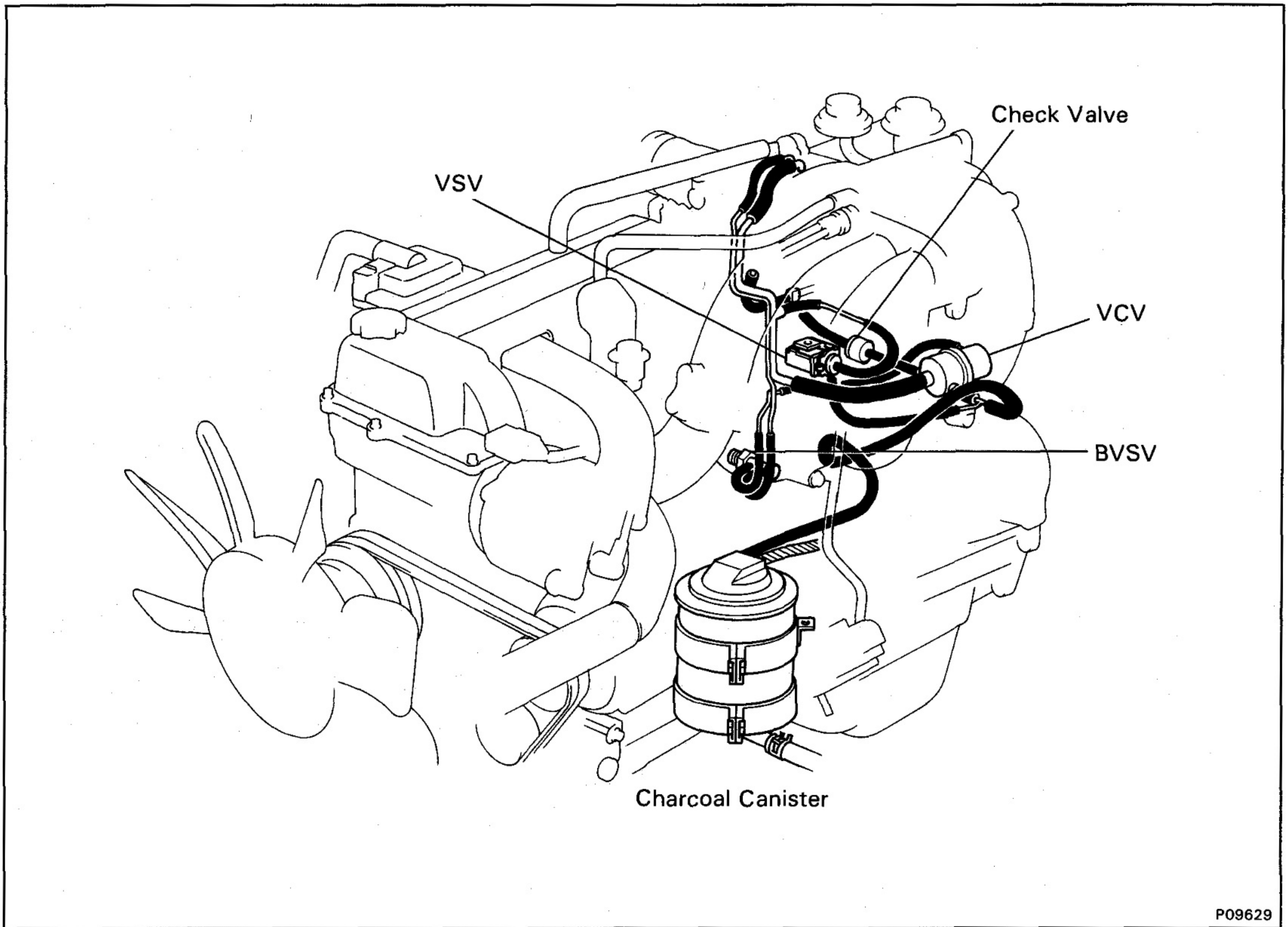

P09629

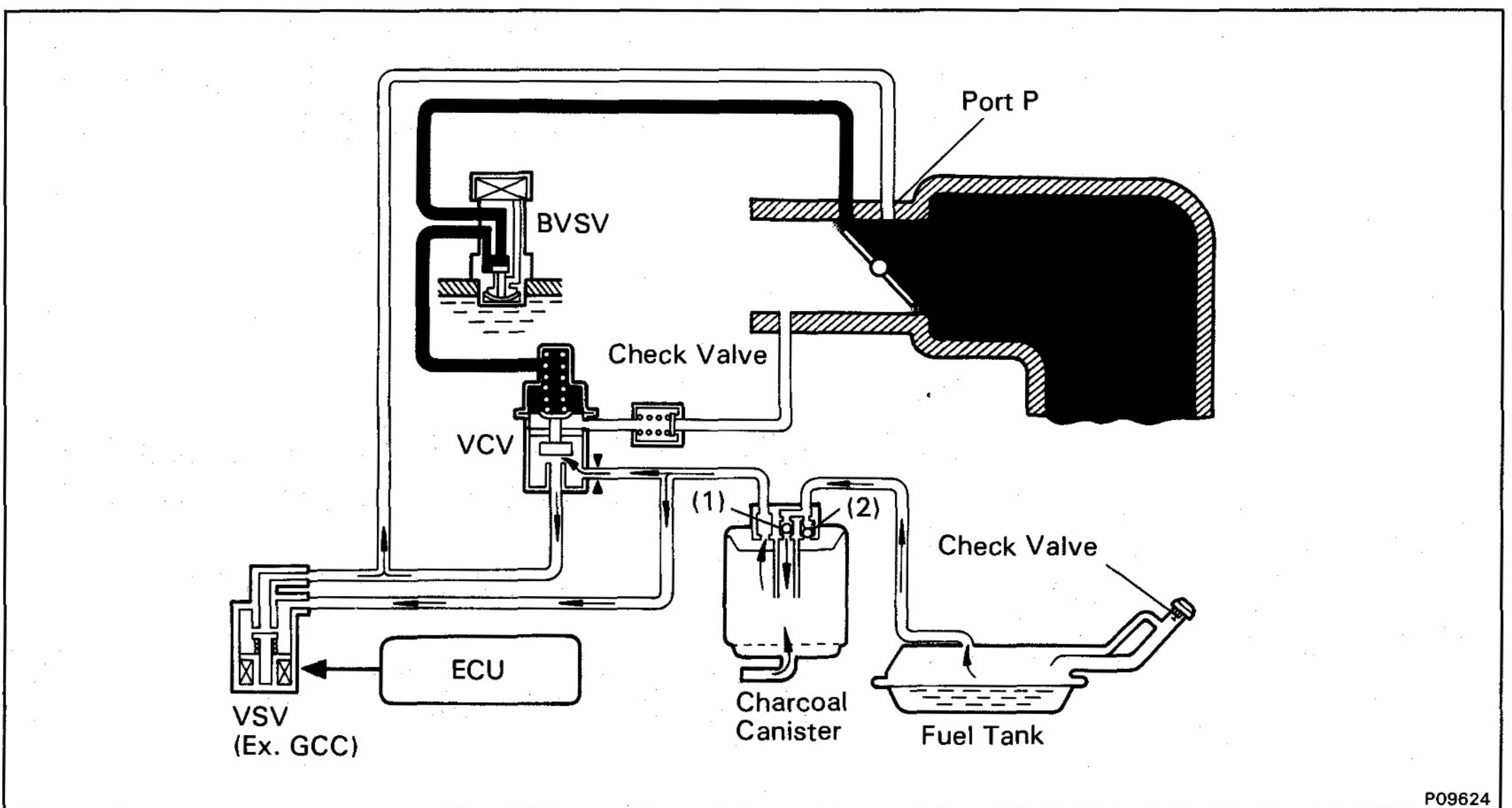

P09624

To reduce HC emission, evaporated fuel from the fuel tank is routed through the charcoal canister to the intake manifold for combustion in the cylinders.

Engine coolant Temp.	BVSV	Throttle Position	VCV	VSV	Check Valve		Check Valve in Cap	Evaporated Fuel (HC)
					(1)	(2)		
Below 45°C (113°F)	CLOSED	—	CLOSED	—	—	—	—	HC From tank is absorbed into the canister.
Above 64°C (147°F)	OPEN	Below port P	CLOSED	—	—	—	—	
		Above port P	OPEN	—	—	—	—	HC from canister is led into air intake chamber.
Above 35°C (95°F) (Ex. GCC)	—	Idling	—	*VALIABLE OPEN	—	—	—	HC from canister is led into air intake chamber.
		Others	—	CLOSE	—	—	—	HC from tank is absorbed into the canister.
High pressure in tank	—	—	—	—	OPEN	CLOSED	CLOSED	HC from tank is absorbed into the canister.
High vacuum in tank	—	—	—	—	CLOSED	OPEN	OPEN	Air is led into the fuel tank.

*The ECU controls the on-off period of the VSV to adjust the EVAP. purge quantity in accordance with the engine load.

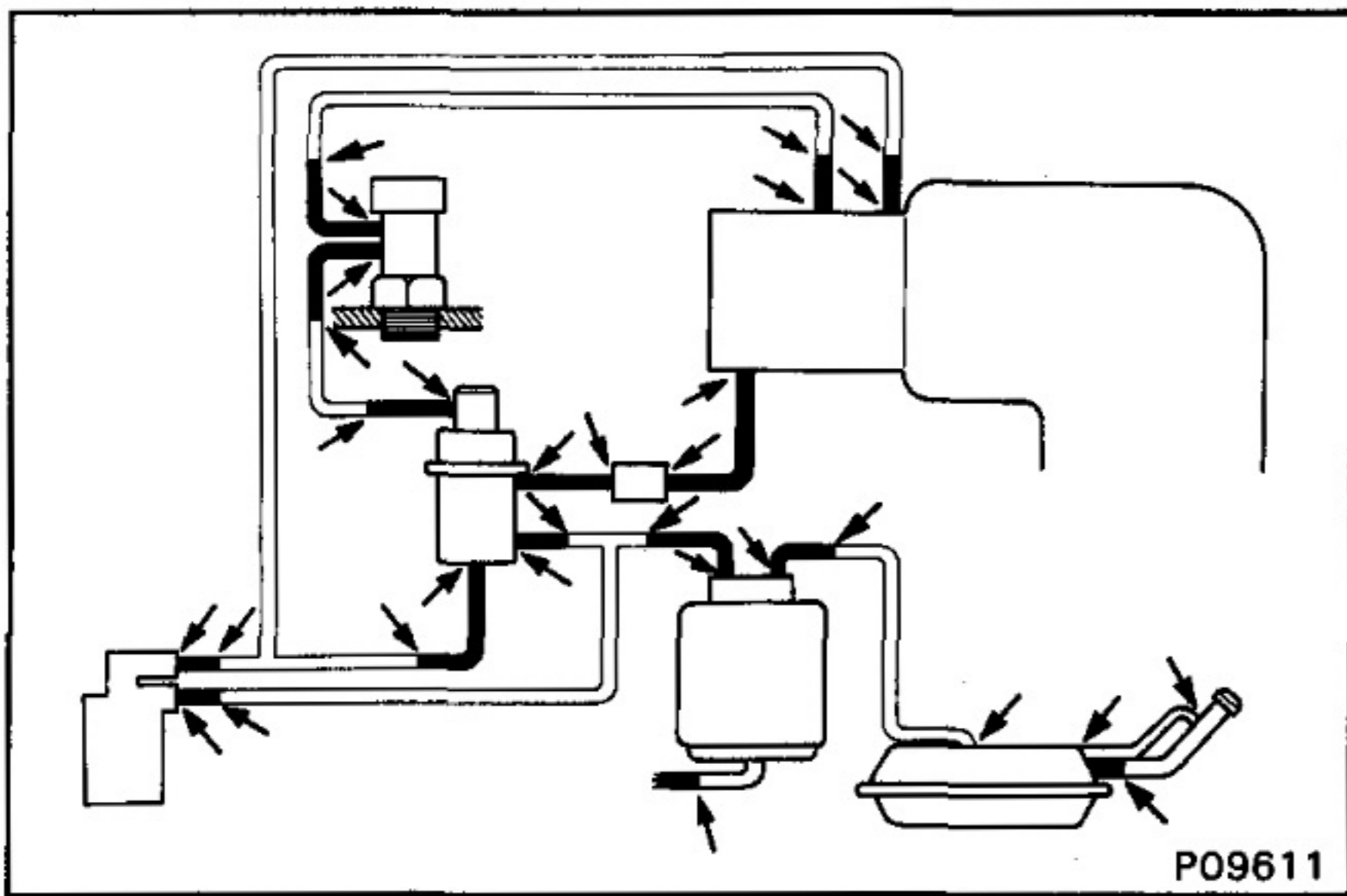

INSPECTION OF EVAP CONTROL SYSTEM

1. **VISUALLY INSPECT LINES AND CONNECTIONS**
Look for loosen connections, sharp bends or damage.
2. **VISUALLY INSPECT FUEL TANK**
Look for deformation, cracks or fuel leakage.
3. **VISUALLY INSPECT FUEL TANK CAP**
Check if the cap and/or gasket are deformed or damaged. If necessary, repair or replace the cap.

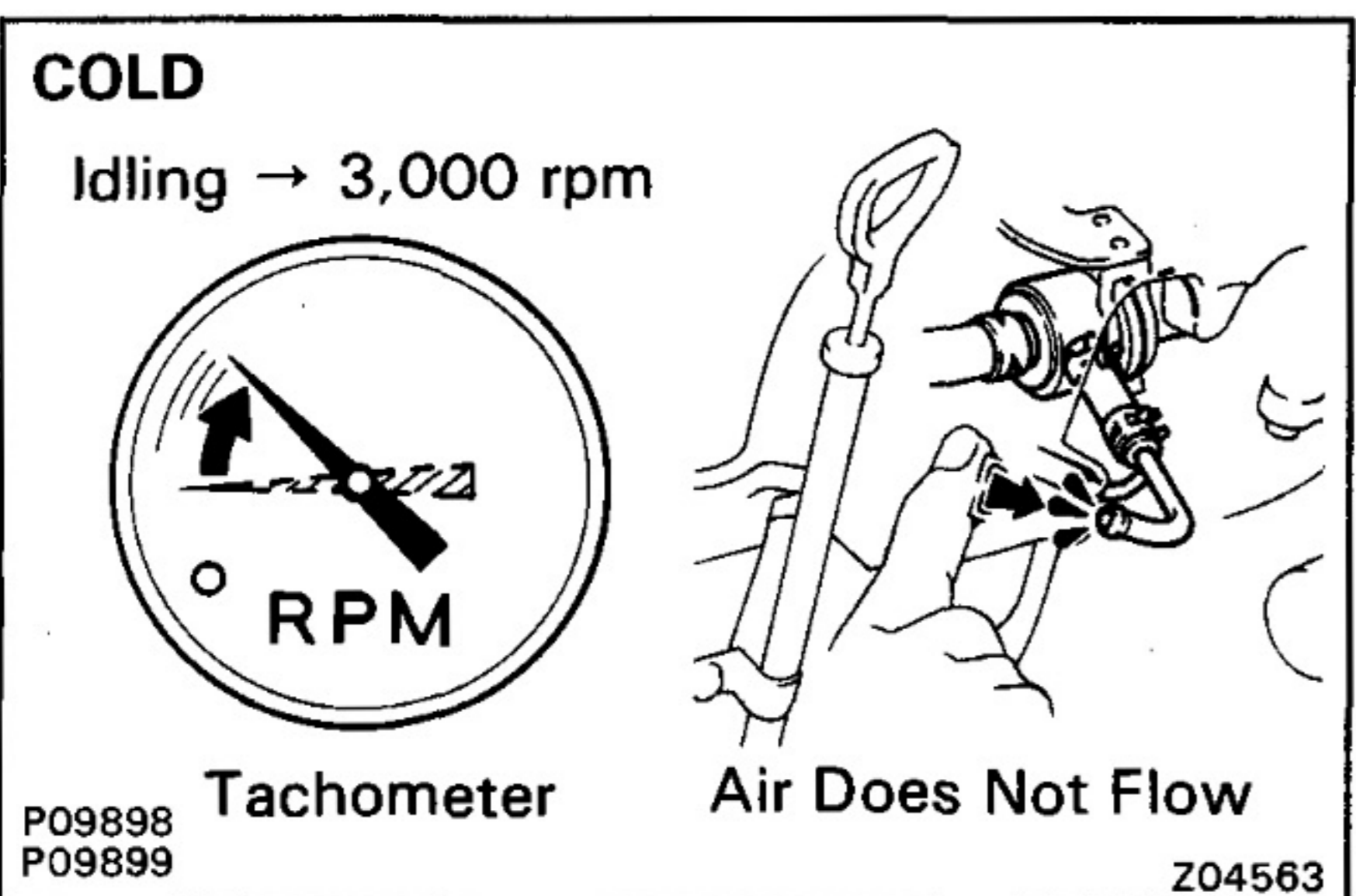
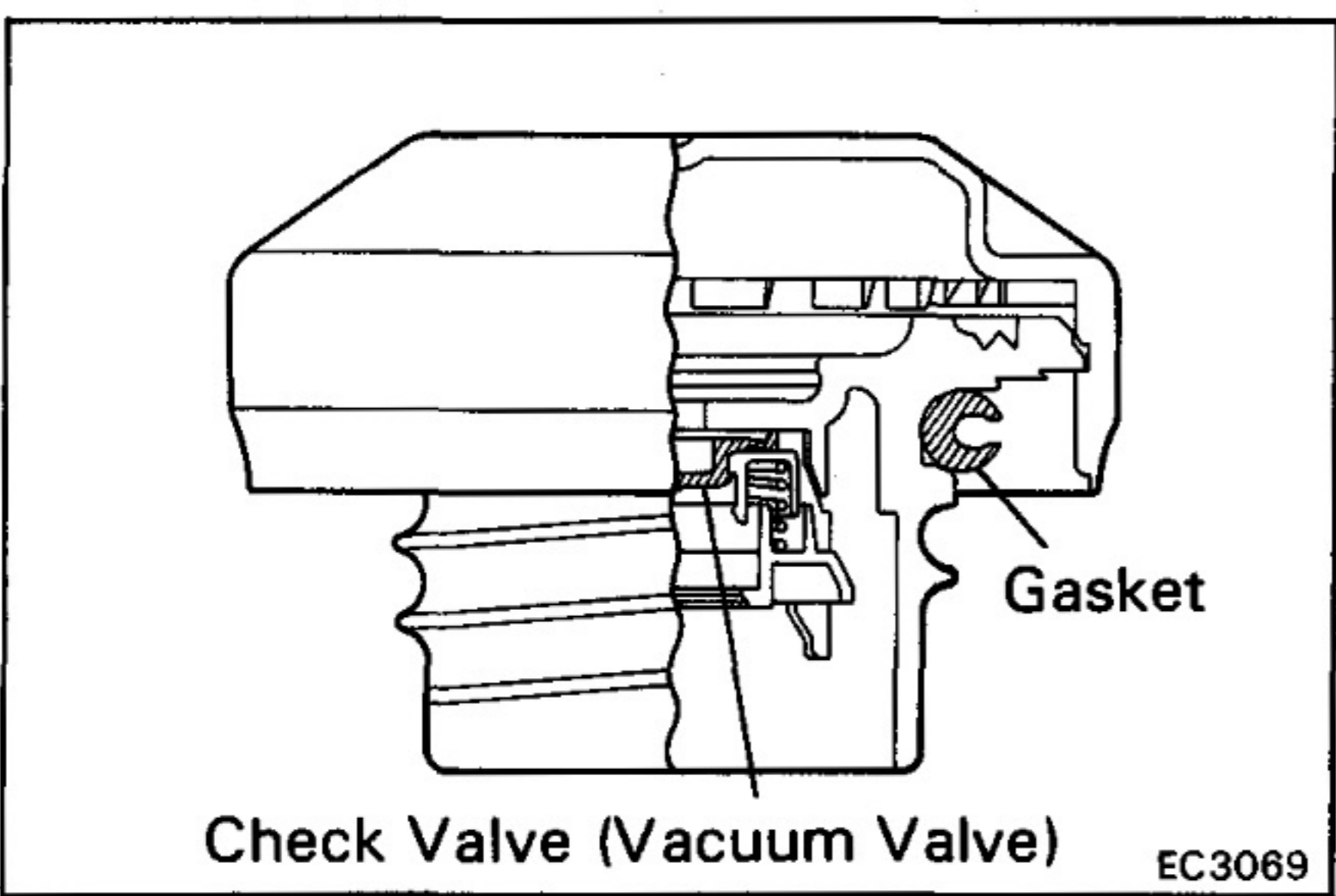

4. **INSPECT BVSV OPERATION WITH COLD ENGINE**
 - (a) The engine coolant temperature should be below 45°C (113°F).
 - (b) Disconnect the EVAP hose from the union pipe.
 - (c) Start the engine.
 - (d) Gradually increase the engine speed from idling to 3,000 rpm and check that air suction is not felt at the union pipe.

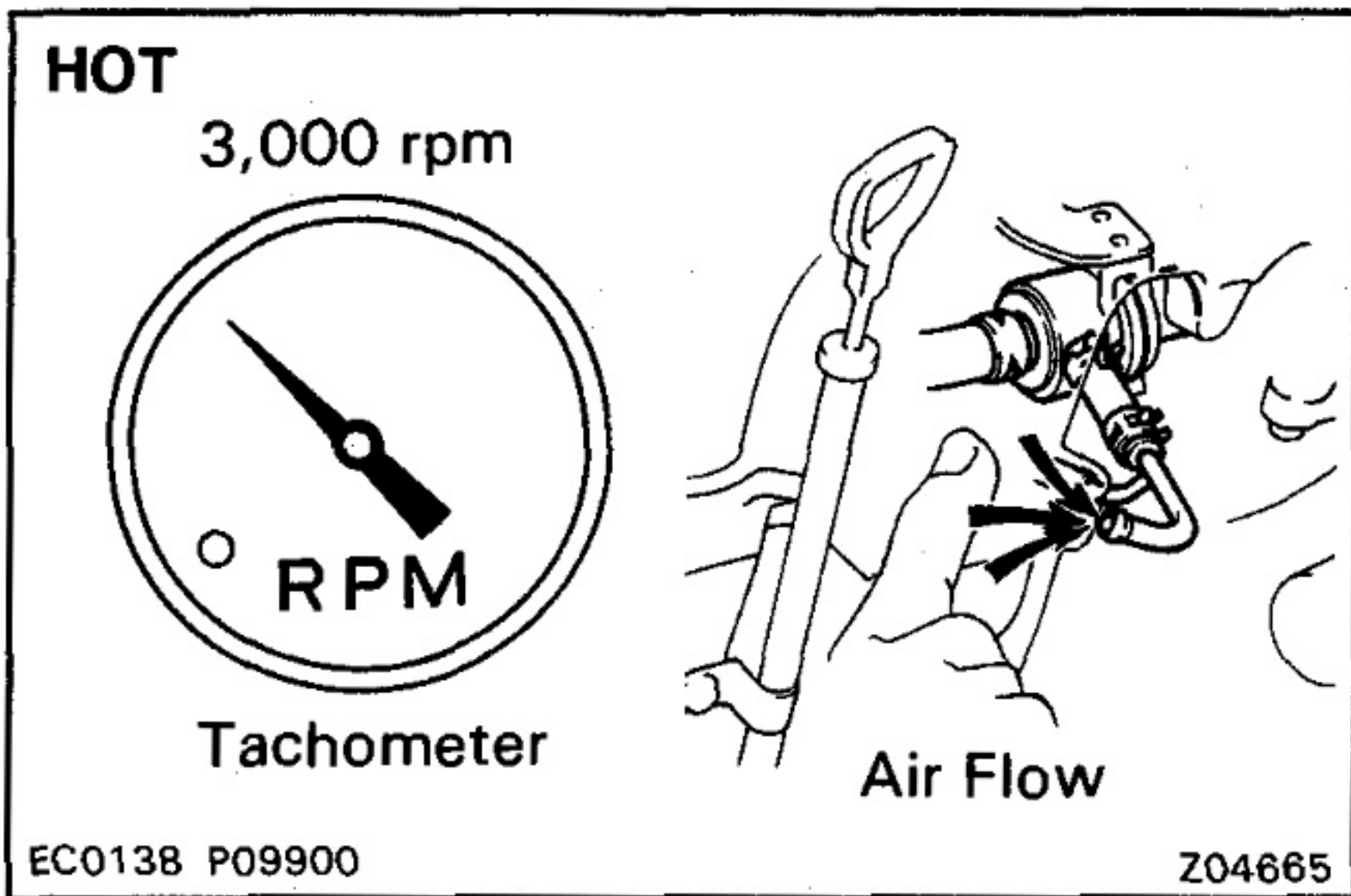
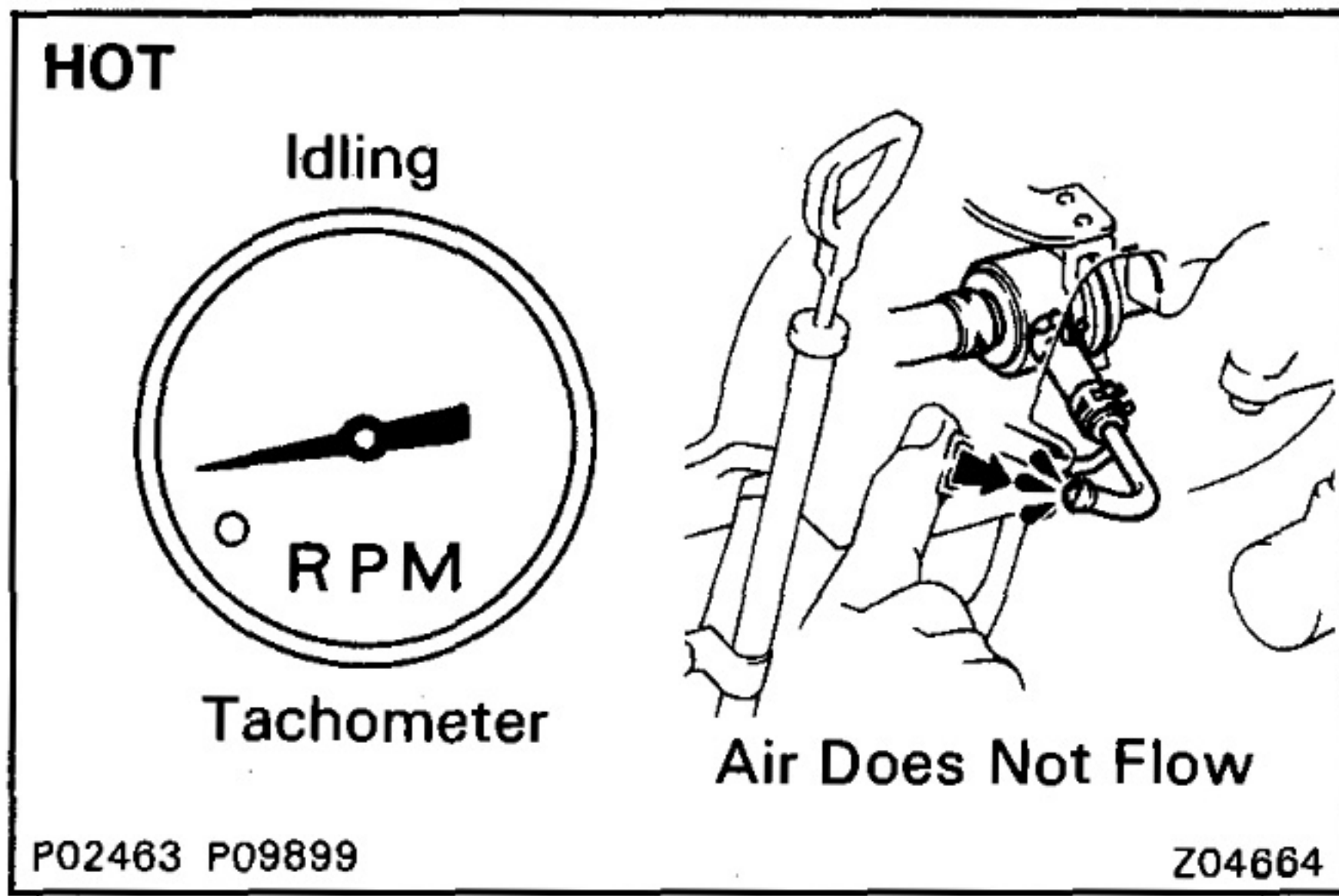

5. INSPECT OPERATION OF VSV AND VCV WITH HOT ENGINE

- (a) Warm up the engine and turn off the A/C switch.
- (b) With the engine idling, check that air suction is not felt at union pipe.

- (c) Gradually increase the engine speed to 3,000 rpm and check that there is air suction at the union pipe.

- (d) Reconnect the EVAP hose to the union pipe.

If you detect a problem when doing the above inspection, inspect each part.

INSPECTION OF CHARCOAL CANISTER

1. REMOVE CHARCOAL CANISTER AND BRACKET
2. DISCONNECT CHARCOAL CANISTER FROM BRACKET
3. REMOVE CAP FROM CHARCOAL CANISTER
4. VISUALLY INSPECT CHARCOAL CANISTER

Lack for cranks or damage.

5. INSPECT FOR CLOGGED FILTER AND STUCK CHECK VALVE

- (a) Using low pressure (4.71 kPa (48 gf/cm², 0.68 psi) or Breath) compressed air, blow into tank pipe and check that air flows without resistance from the other pipes.

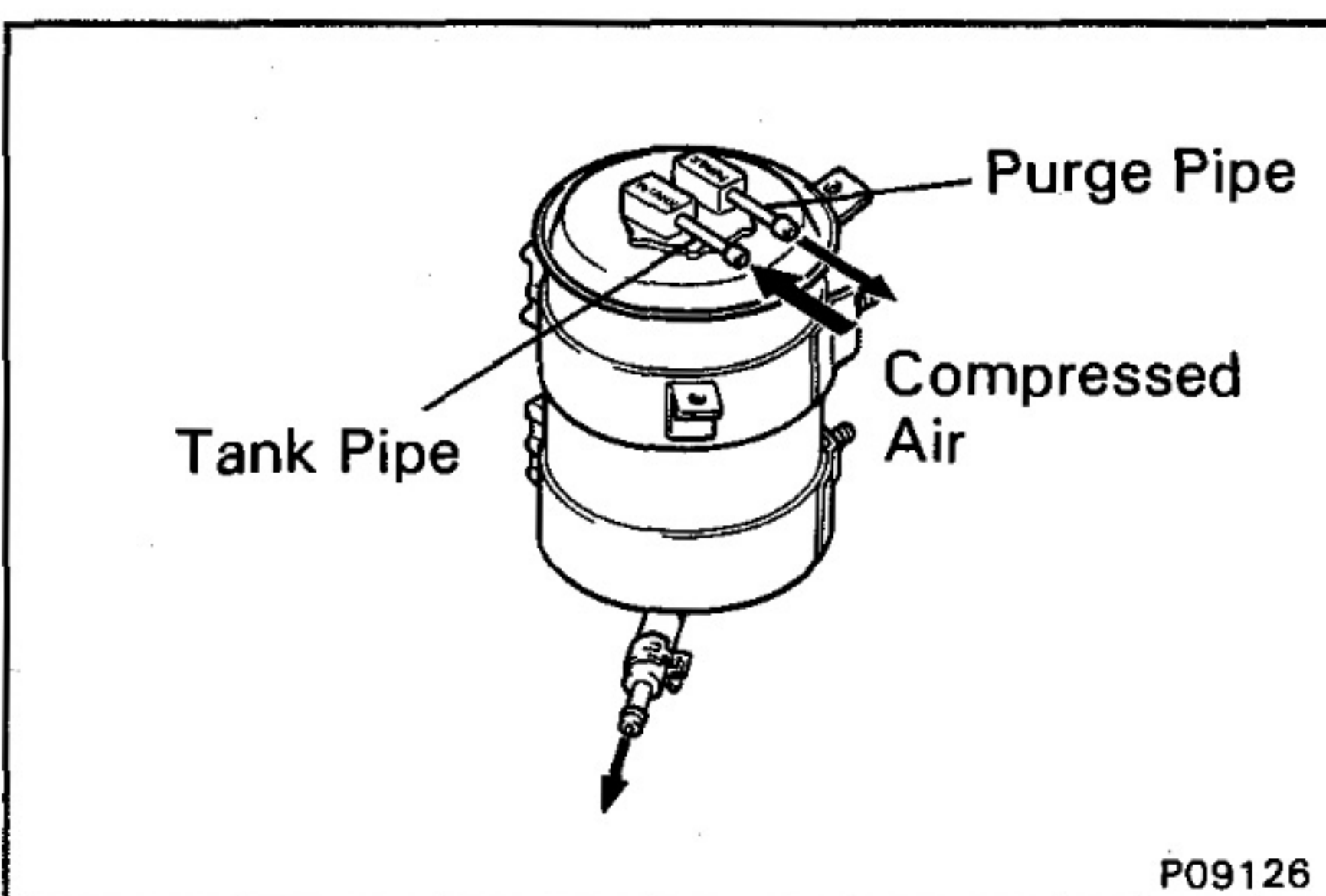
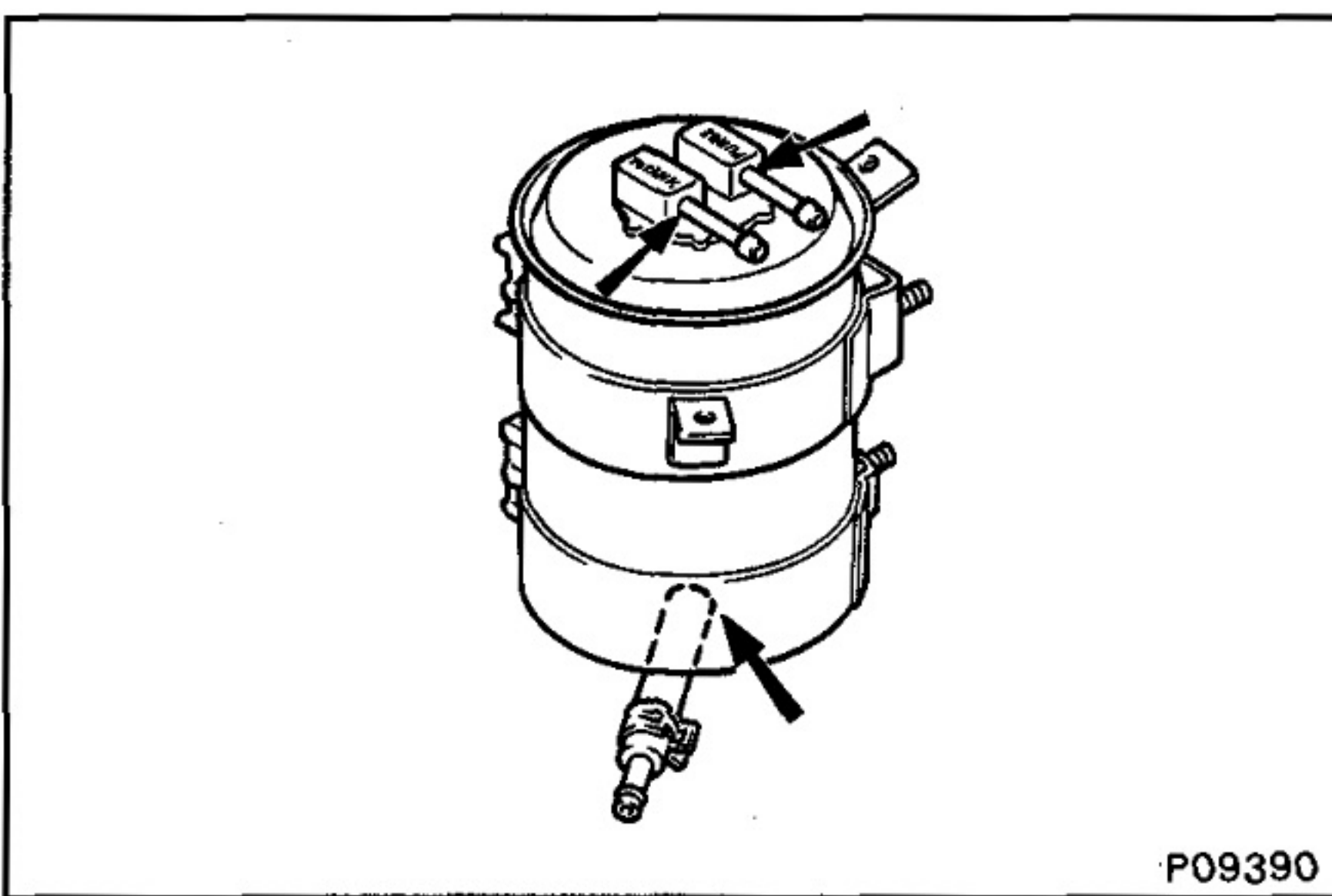

- (b) Blow into purge pipe and check that air does not flow from the other pipes.

If operation is not as specified, replace the charcoal canister.

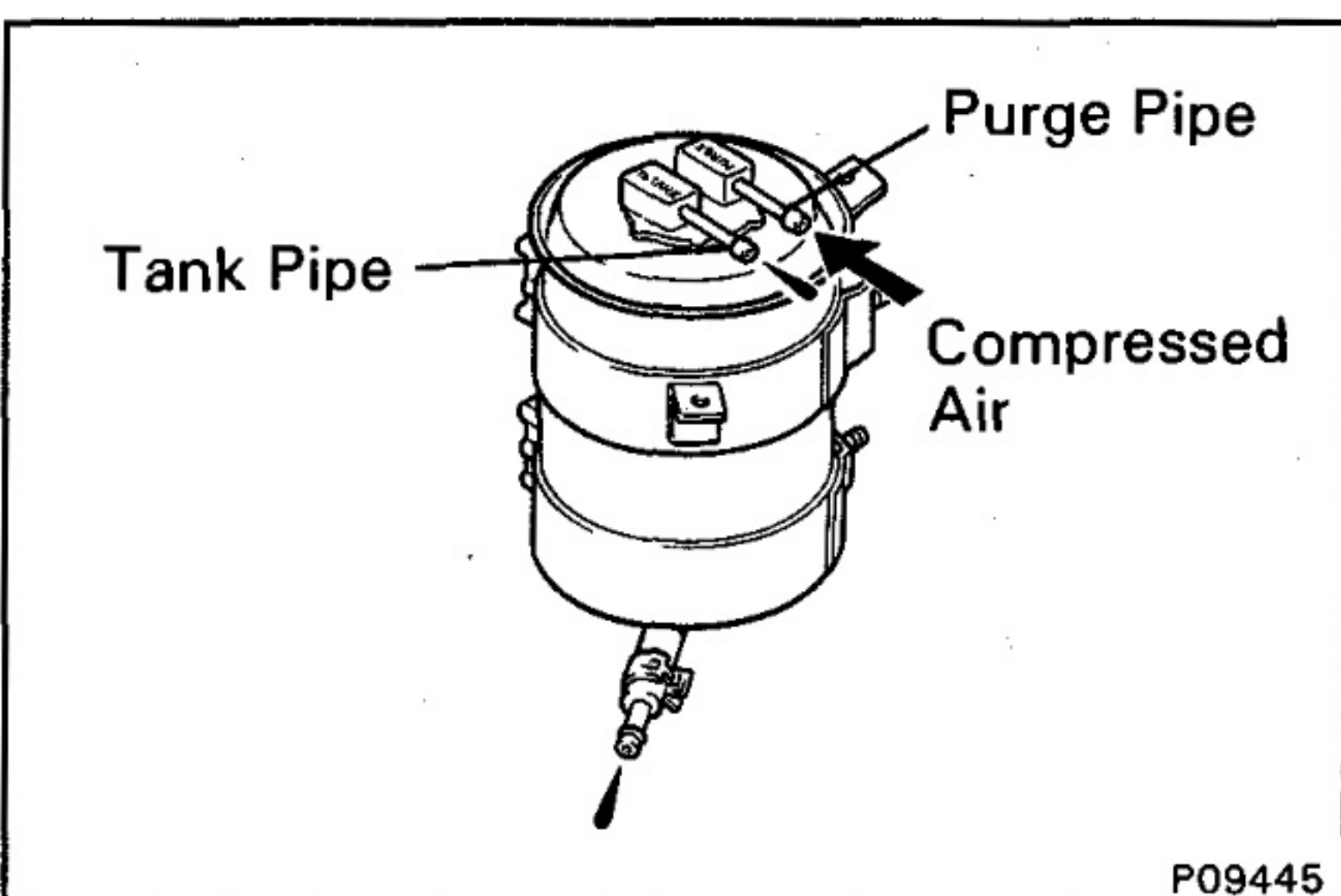

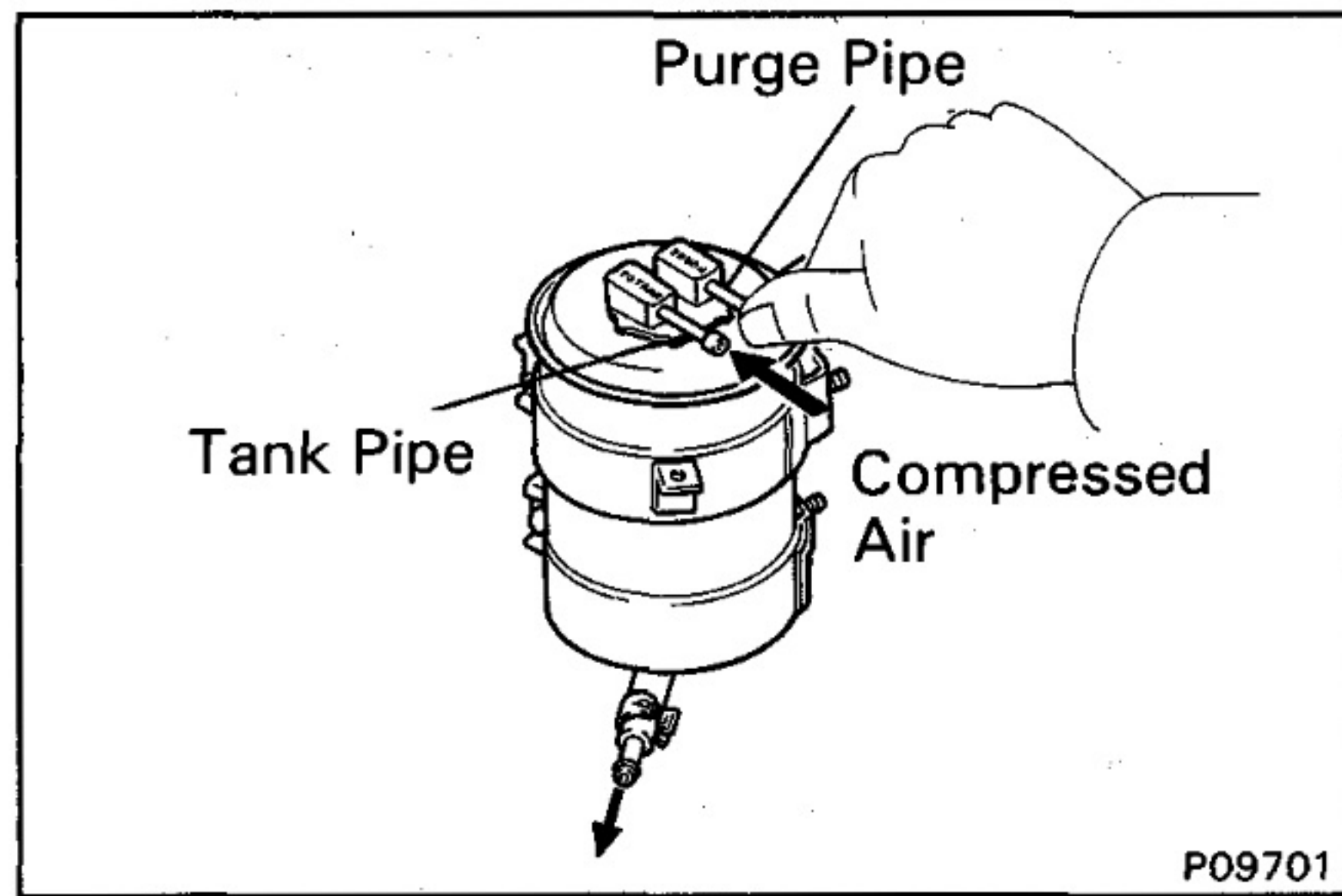
**6. CLEAN FILTER IN CANISTER**

Clean the filter by blowing 294 kPa (3 kgf/cm², 43 psi) of compressed air into tank pipe while holding purge pipe closed.

NOTICE:

- Do not attempt to wash the canister.
- No activated carbon should come out.

7. REINSTALL CAP TO CHARCOAL CANISTER**8. RECONNECT CHARCOAL CANISTER TO BRACKET**

Torque: 14 N·m (145 kgf·cm, 10 ft·lbf)

9. REINSTALL CHARCOAL CANISTER AND BRACKET

Torque: 18 N·m (185 kgf·cm, 13 ft·lbf)

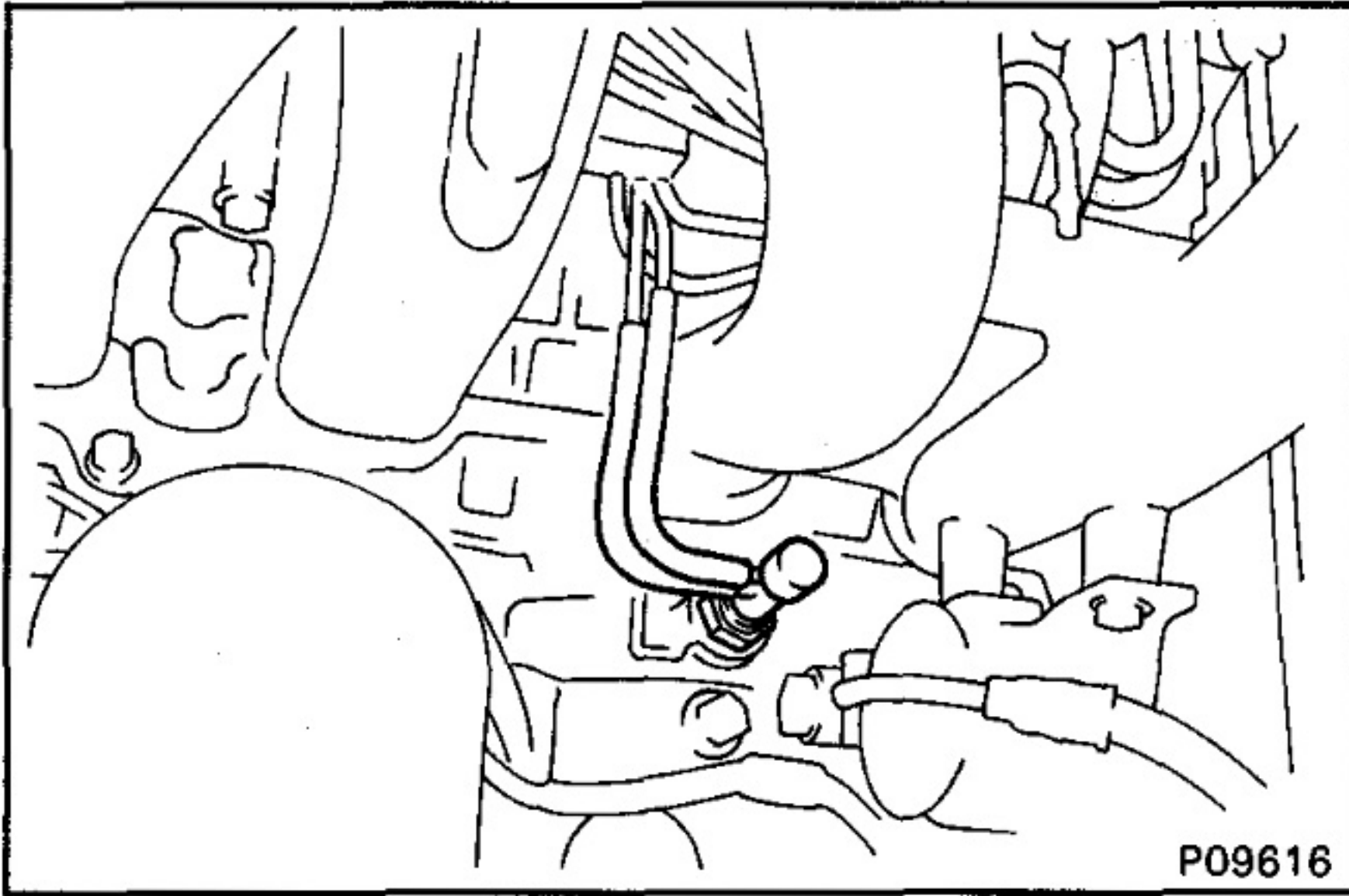

INSPECTION OF BVSV

1. DRAIN ENGINE COOLANT

2. REMOVE BVSV FROM CYLINDER HEAD

- (a) Disconnect the two vacuum hoses.
- (b) Remove the BVSV.

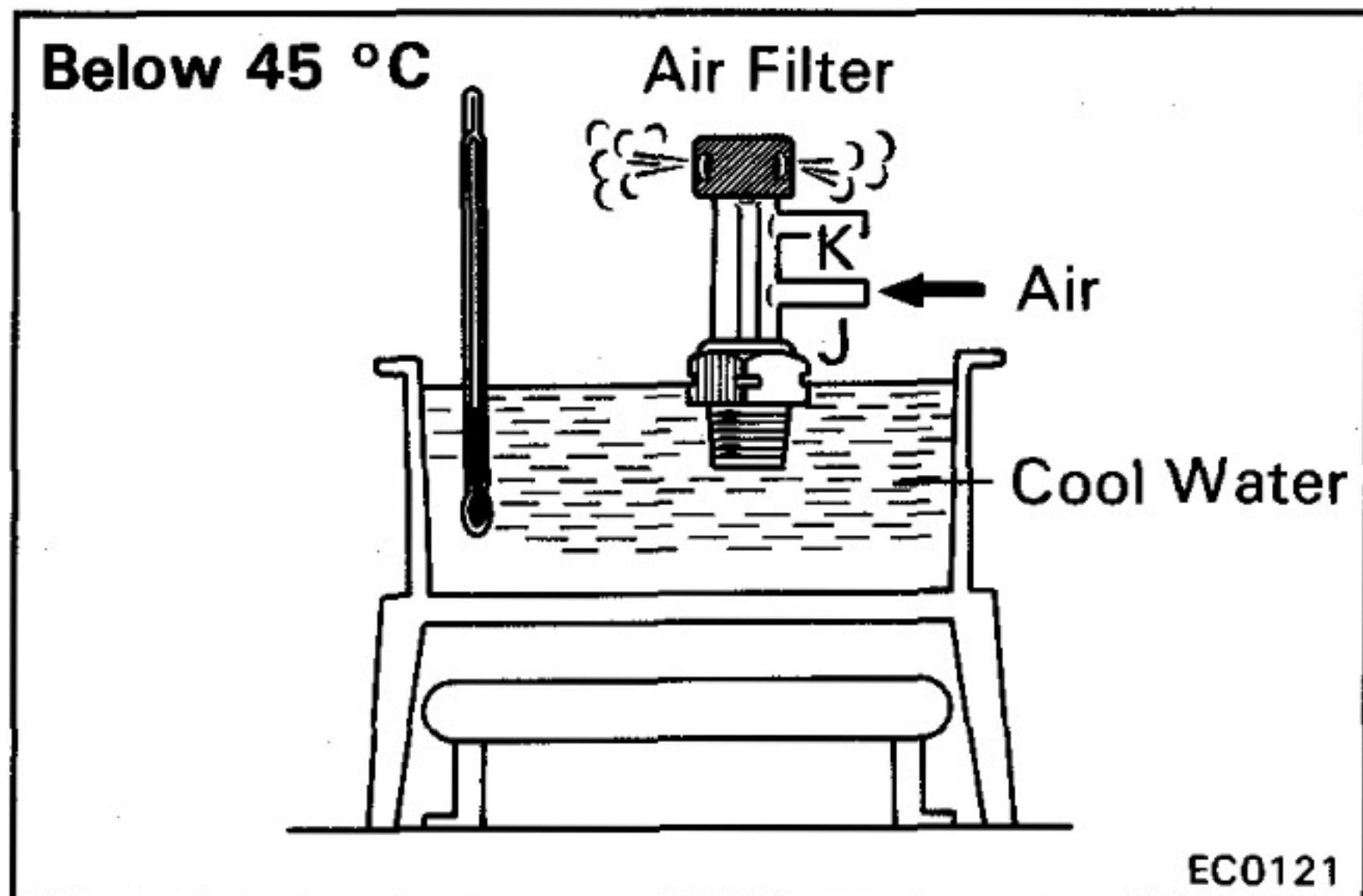

3. INSPECT BVSV OPERATION

- (a) Cool the BVSV to below 45°C (113°F) with cool water.
- (b) Check that air flows from the pipe J to the air filter.

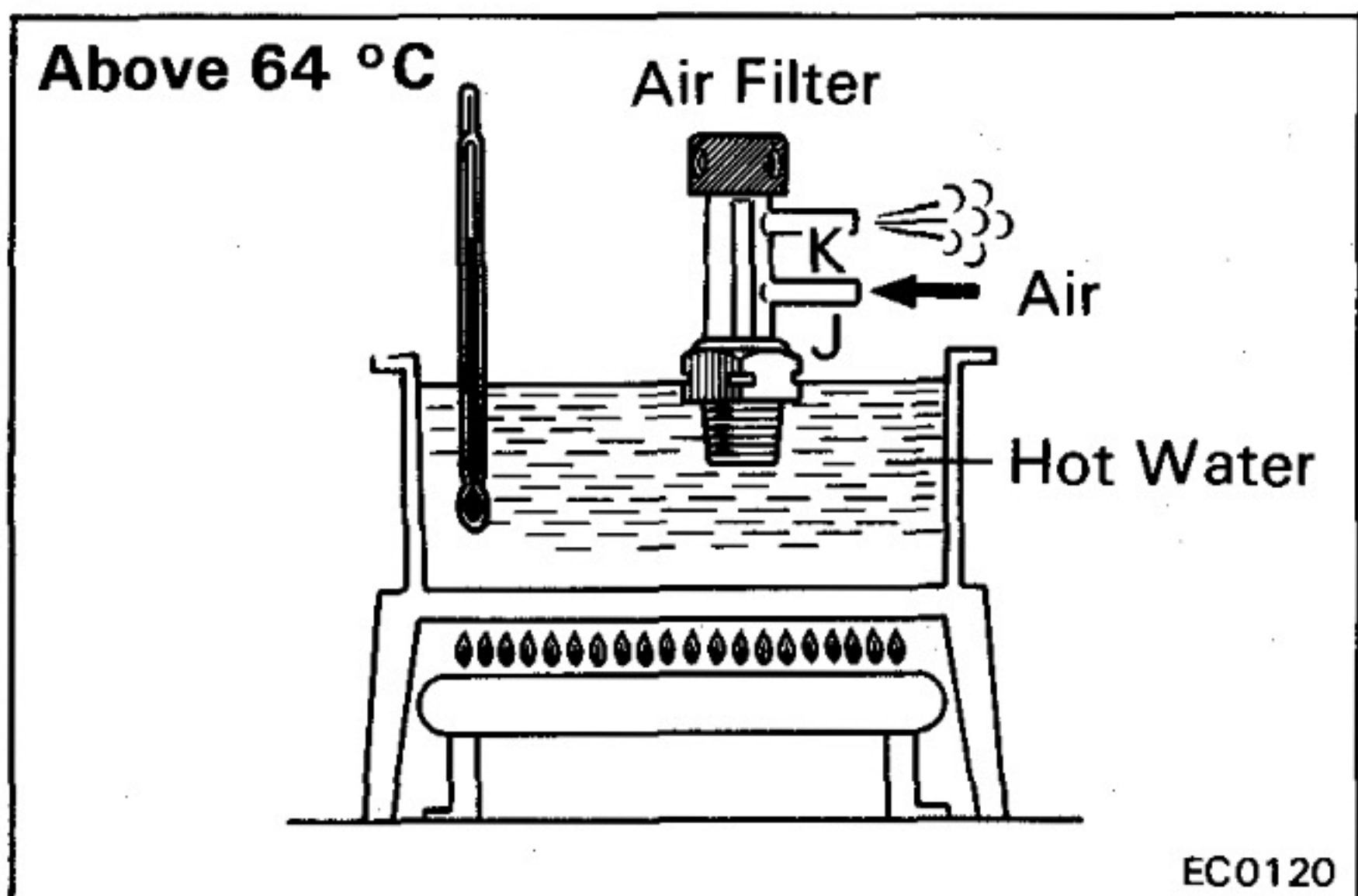

- (c) Heat the BVSV to above 64°C (147°F) with hot water.
 - (d) Check that air flows from the pipe J to pipe K.
- If operation is not as specified, replace the BVSV.

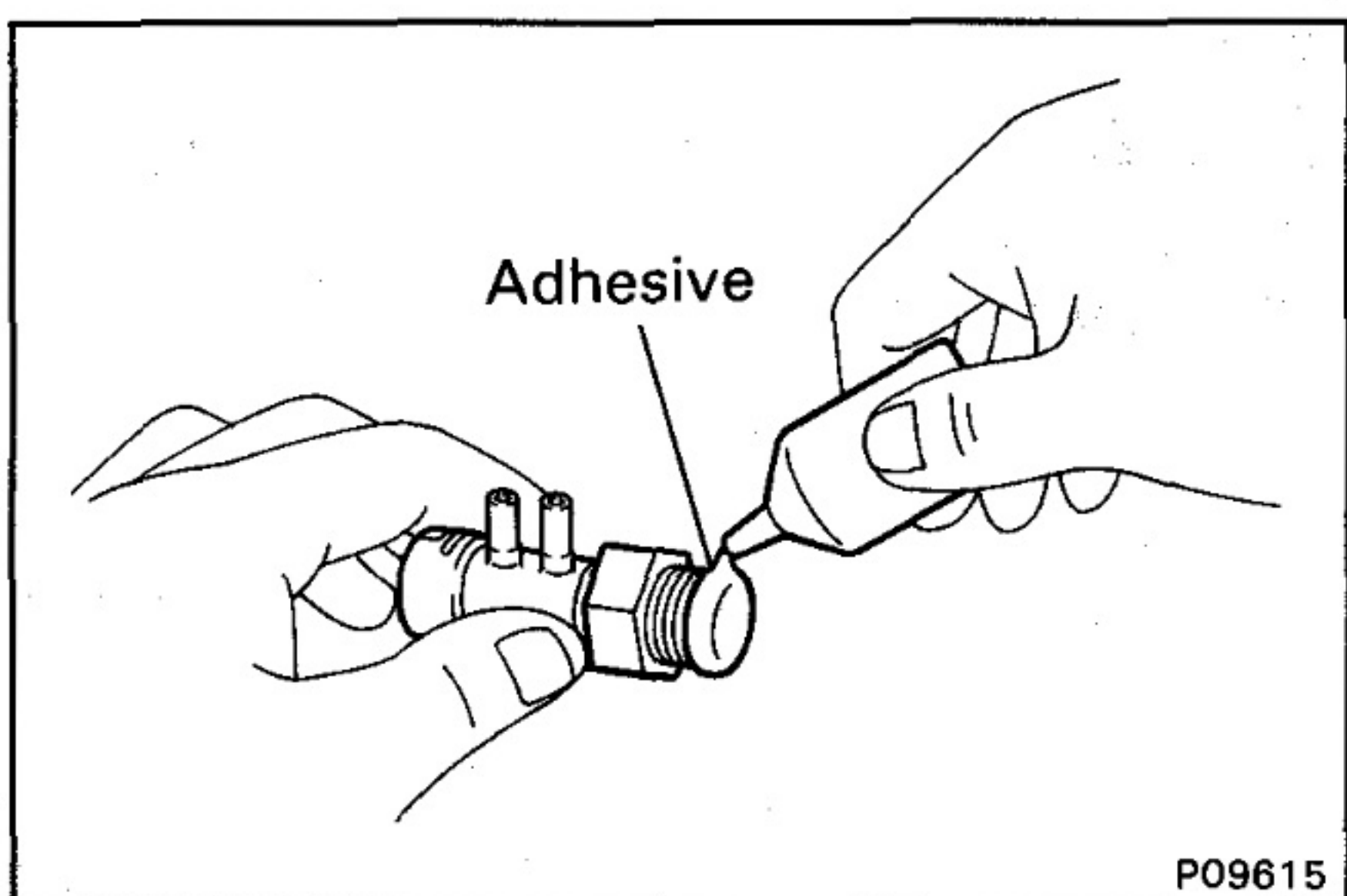

4. REINSTALL BVSV

- (a) Apply adhesive to two or three threads of the BVSV and install it.

Adhesive:

Part No. 08833-00070, THREE BOND 1324 or equivalent

Torque: 29 N·m (300 kgf·cm, 22 ft·lbf)

- (b) Reconnect two vacuum hoses.

5. REFILL WITH ENGINE COOLANT

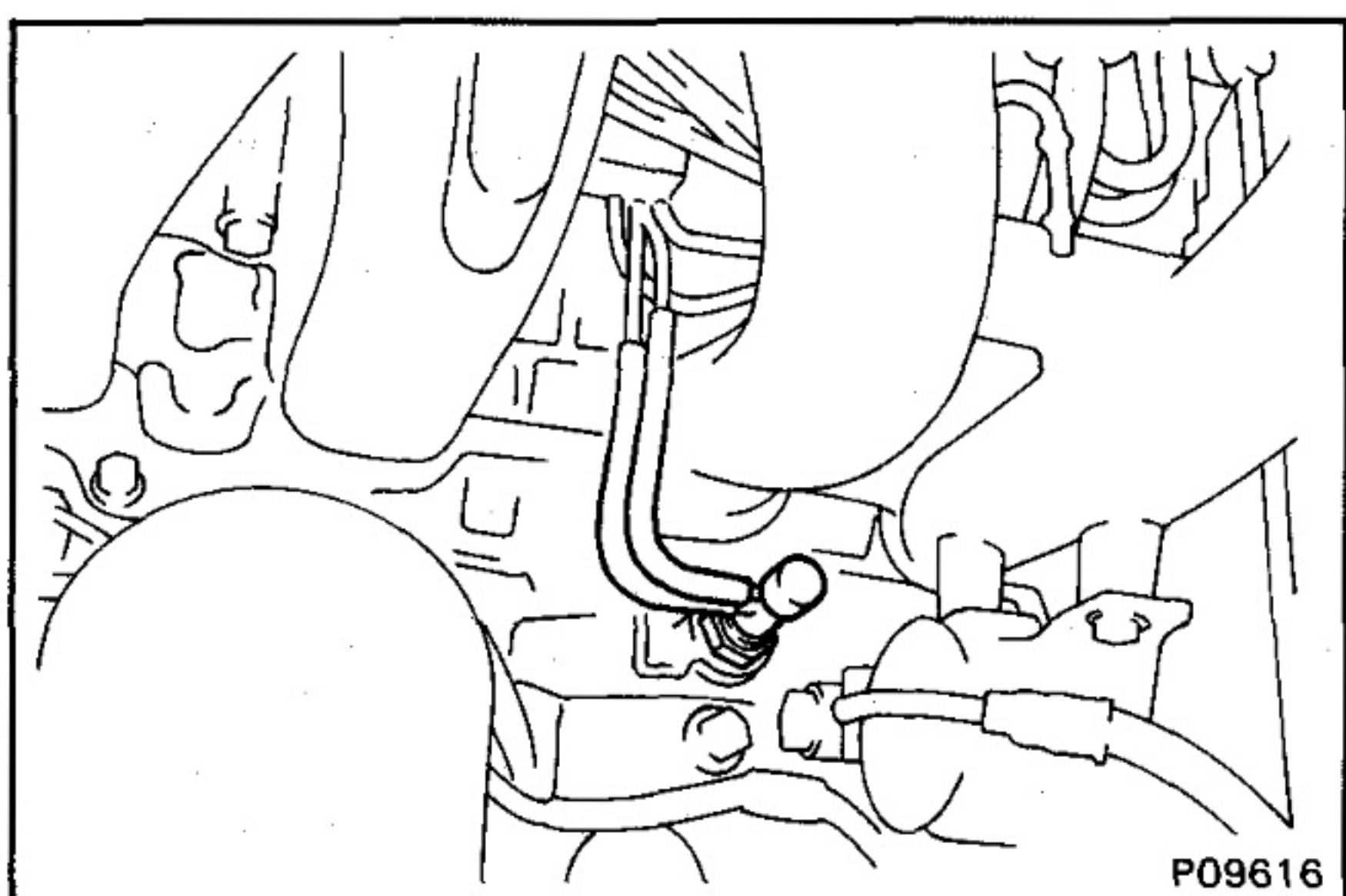

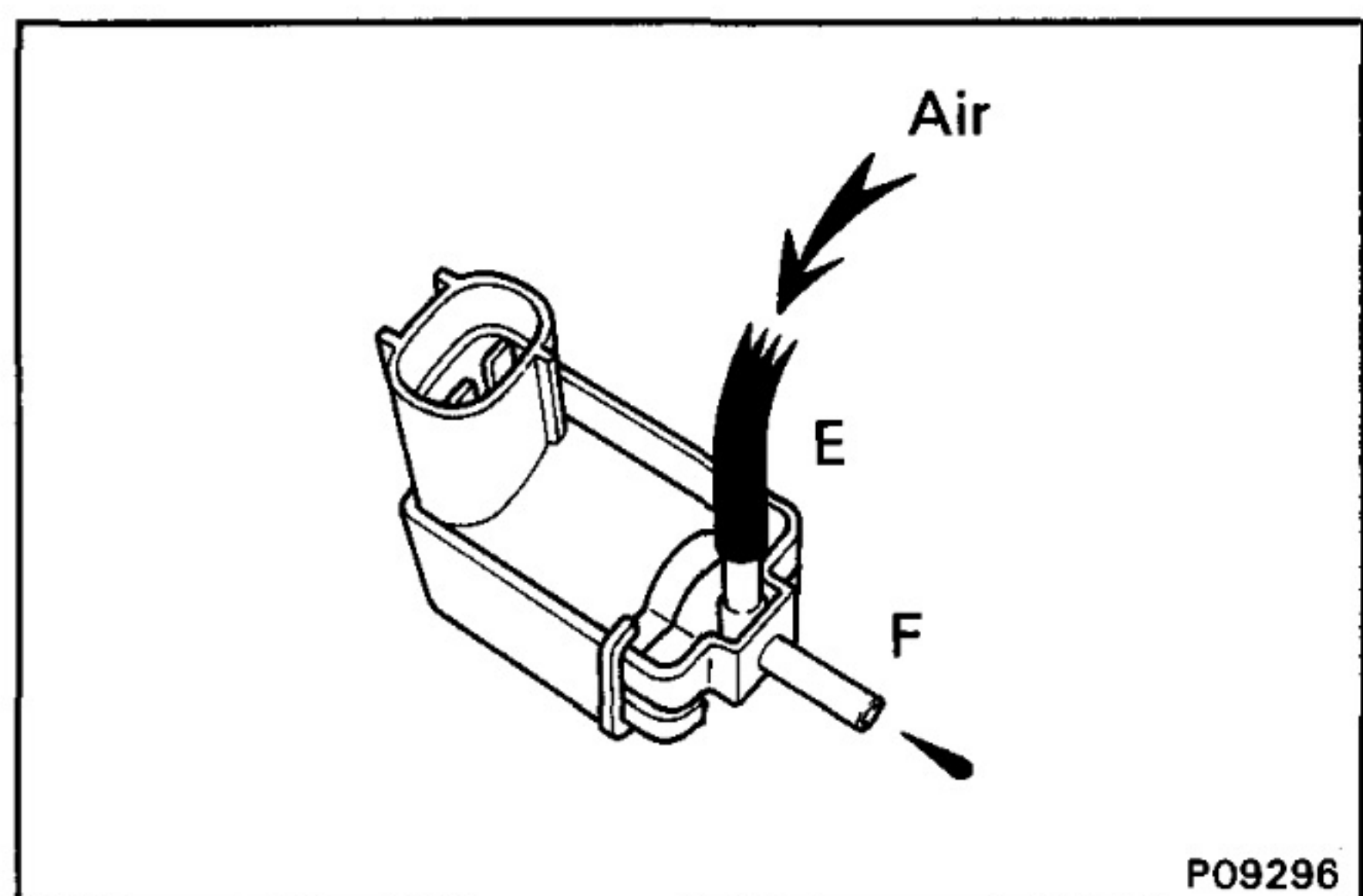
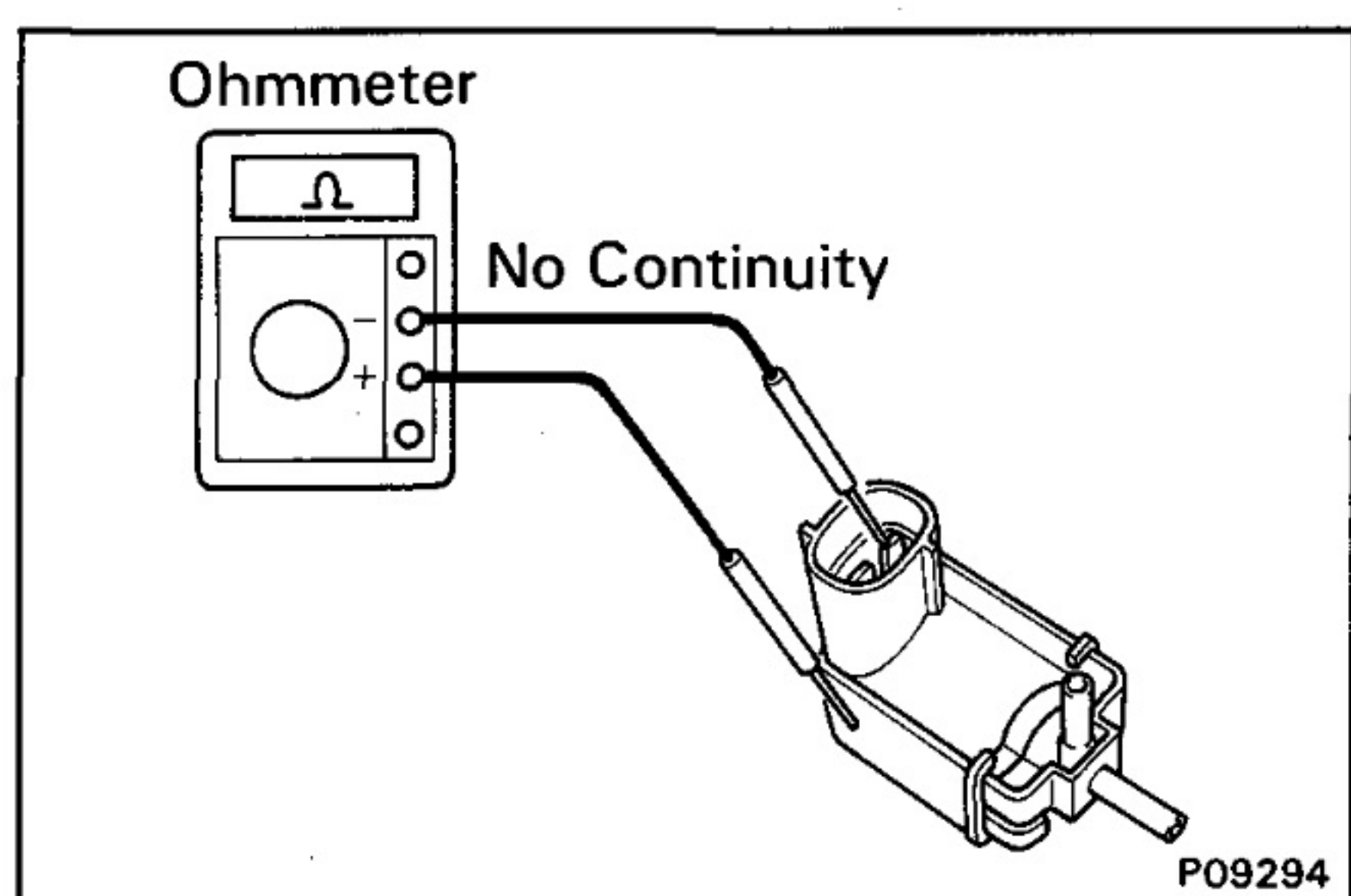
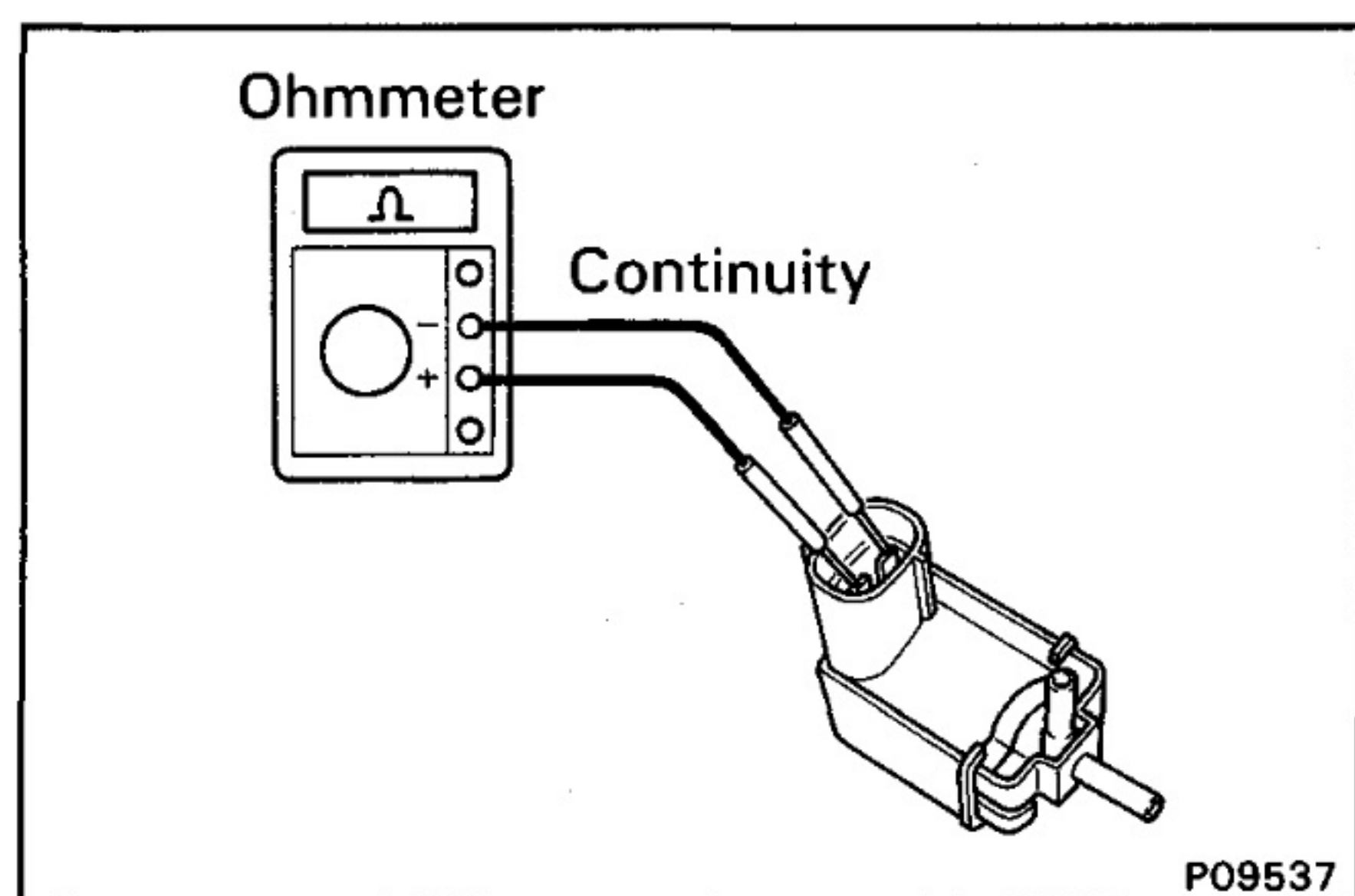
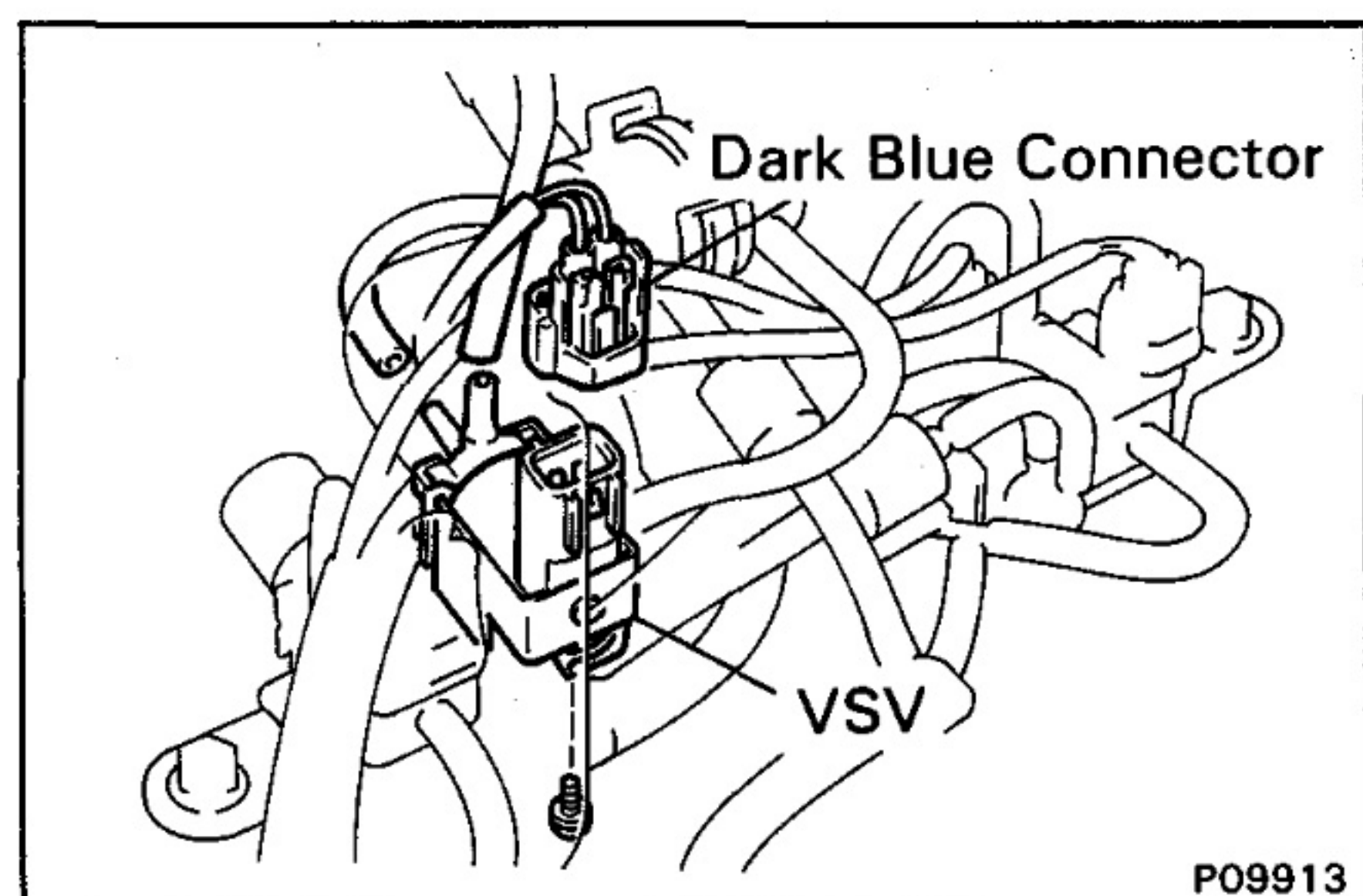
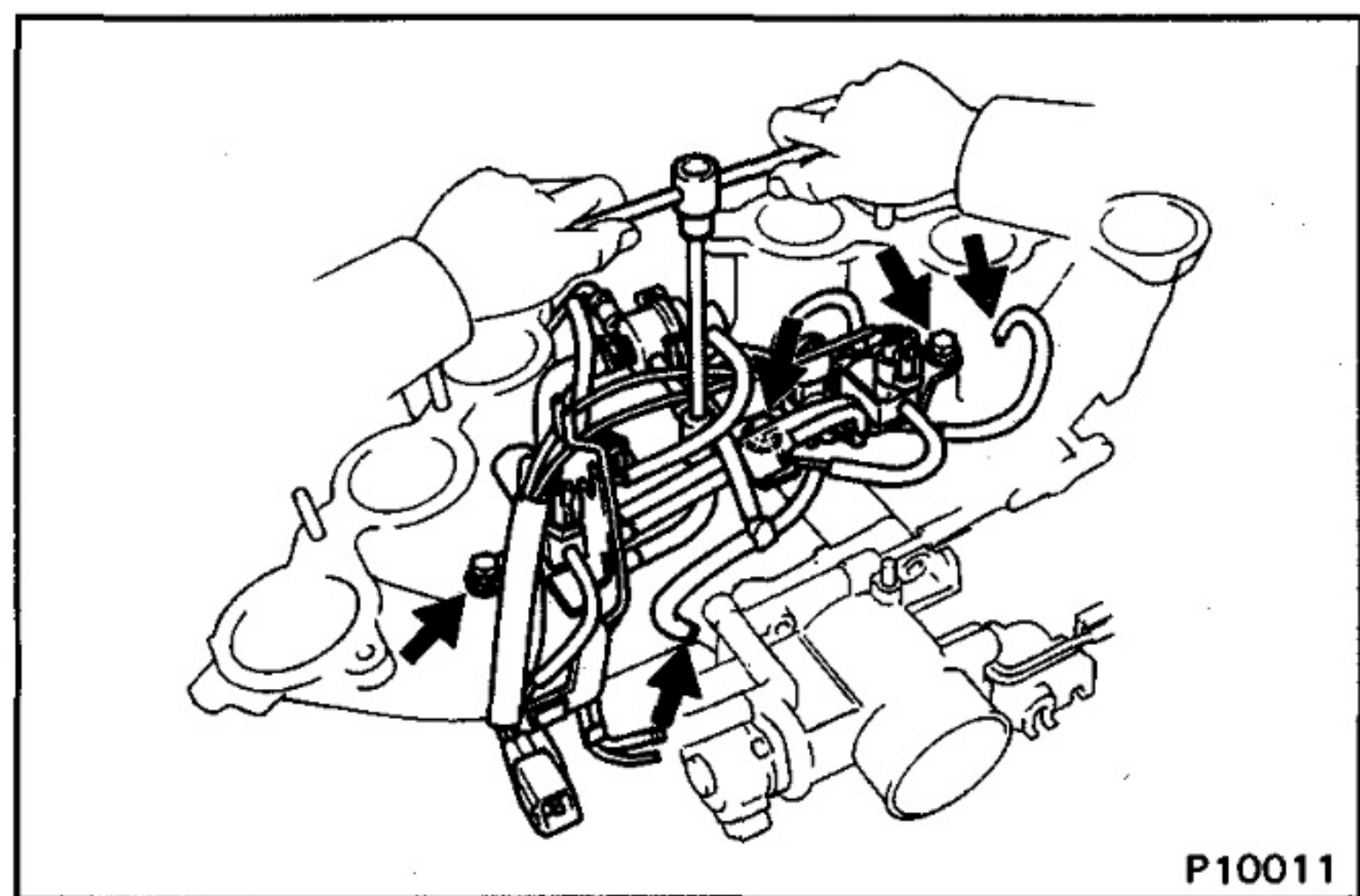

INSPECTION OF VSV

1. REMOVE AIR INTAKE CHAMBER

2. REMOVE VSV

- (a) Disconnect the air hose and vacuum hose from the air intake chamber.
- (b) Remove the four bolts and emission control valve set assembly.
- (c) Disconnect the connector and two vacuum hoses, and remove the screw and VSV.

3. INSPECT VSV

A. Inspect VSV for open circuit

Using an ohmmeter, check that there is continuity between the terminals.

Resistance:

30 – 33 Ω at 20°C (68°F)

If there is no continuity, replace the VSV.

B. Inspect VSV for ground

Using an ohmmeter, check that there is no continuity between each terminal and the body.

If there is continuity, replace the VSV.

C. Inspect VSV operation

- (a) Check that the air does not flow from pipe E to pipe F.

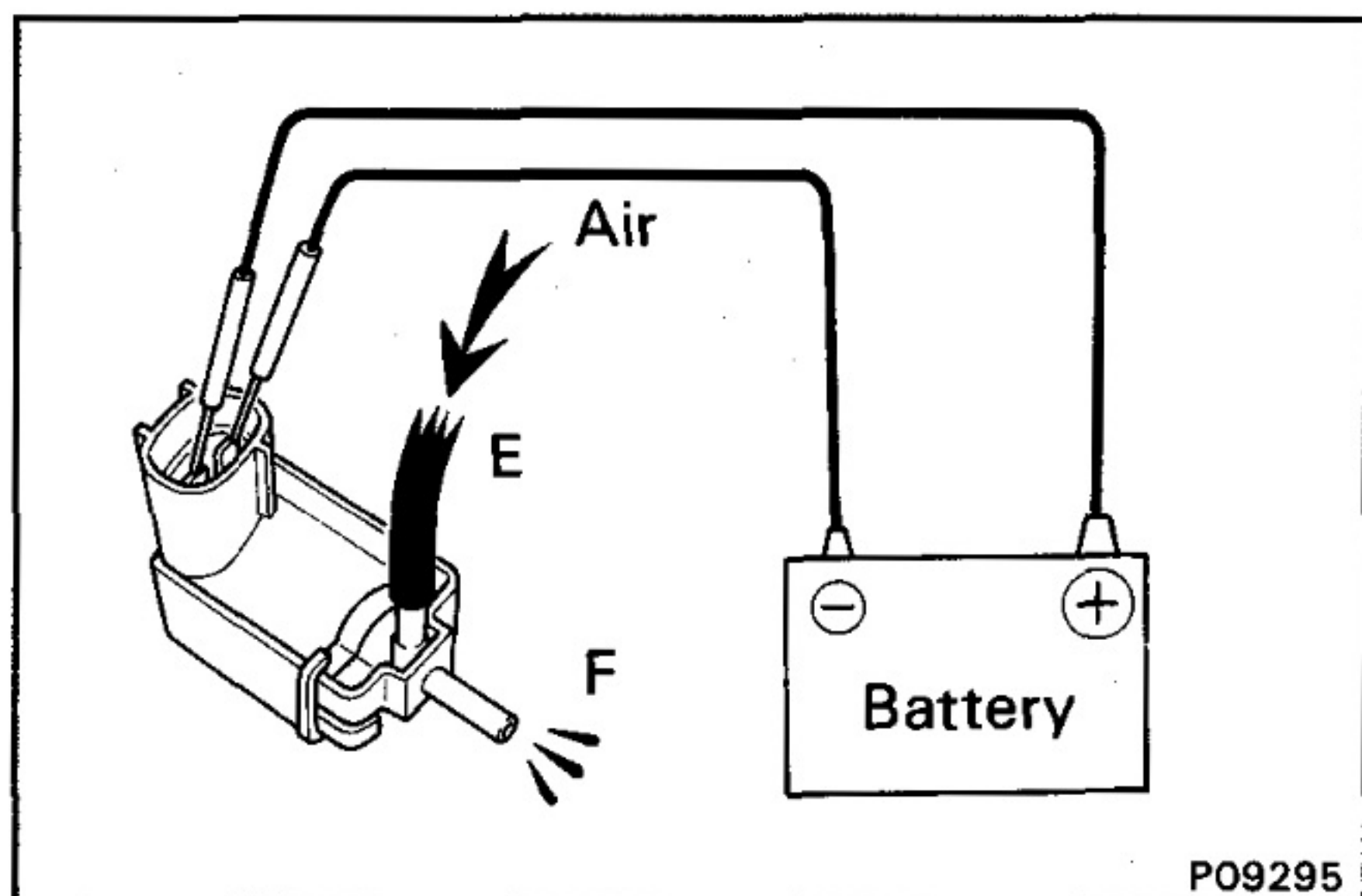

- (b) Apply battery voltage across the terminals.
- (c) Check that the air flows from pipe E to the pipe F.
If operation is not as specified, replace the VSV.

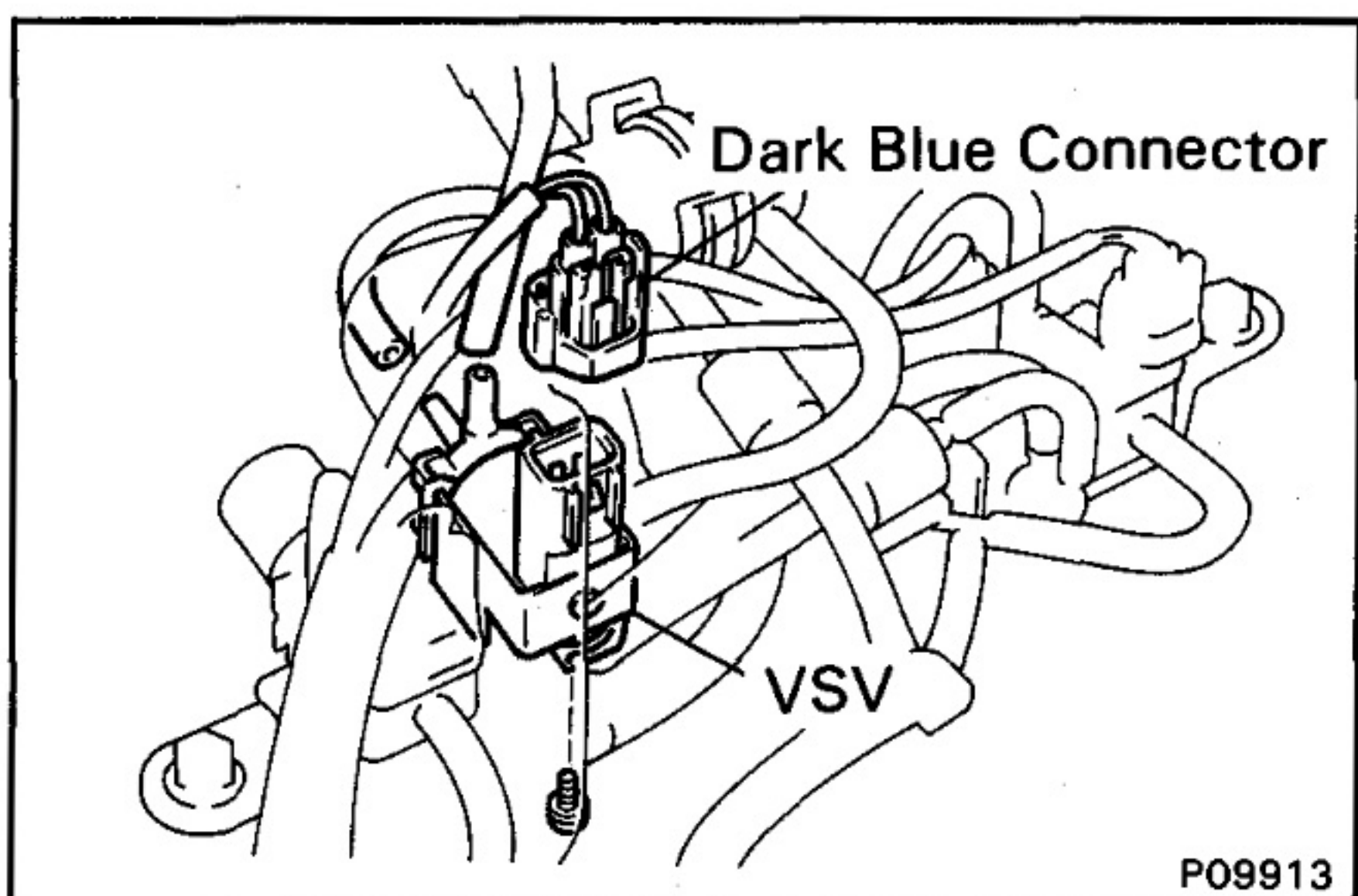

4. REINSTALL VSV

- (a) Install the VSV with the screws.
- (b) Connect the connector and two vacuum hoses to the VSV.

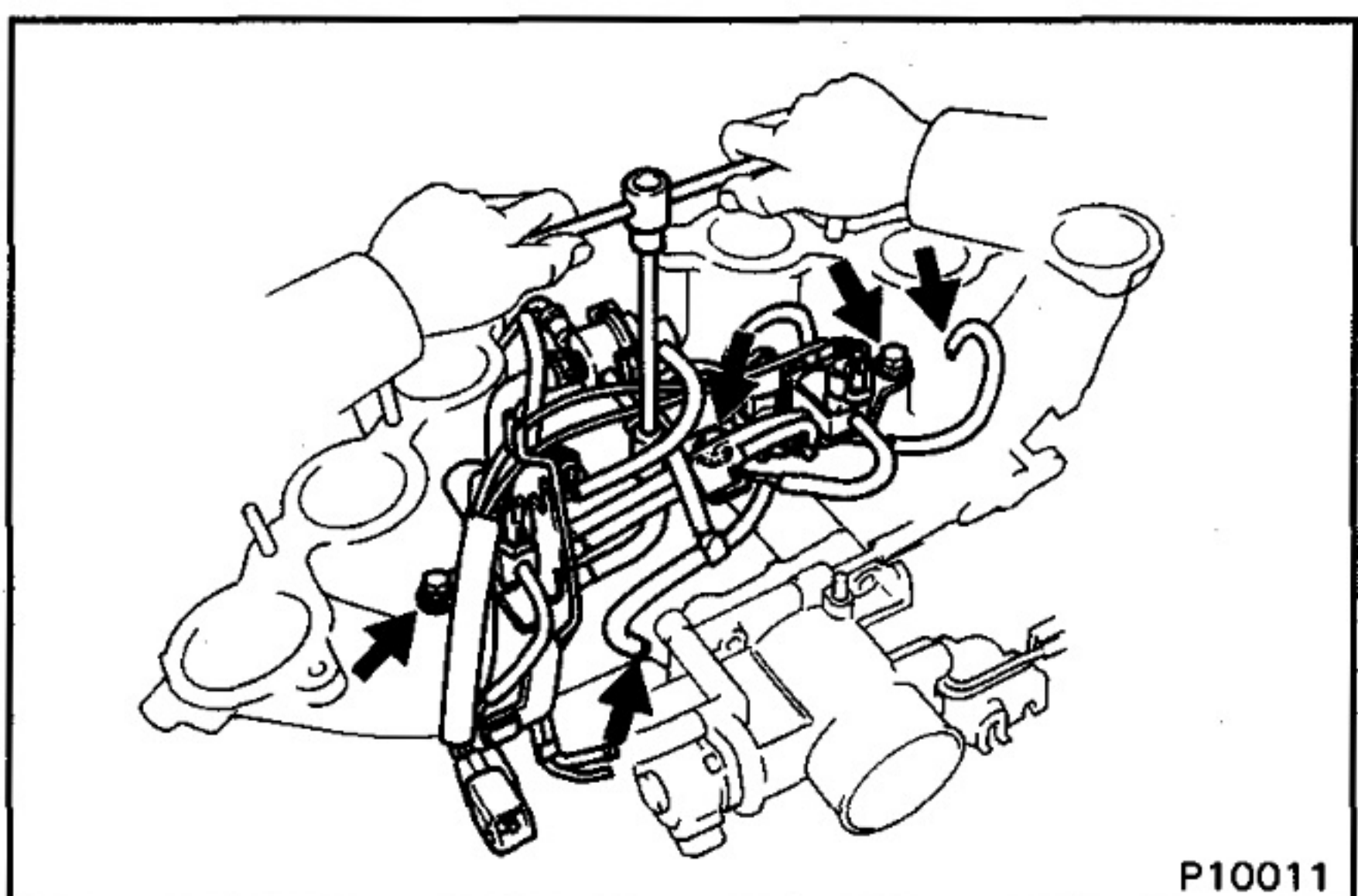

- (c) Install the emission control valve set assembly with the four bolts.

Torque: 20 N·m (200 kgf·cm, 14 ft·lbf)

- (d) Connect the air hose and vacuum hose to the air intake chamber.

5. REINSTALL AIR INTAKE CHAMBER

INSPECTION OF VCV

1. REMOVE VCV

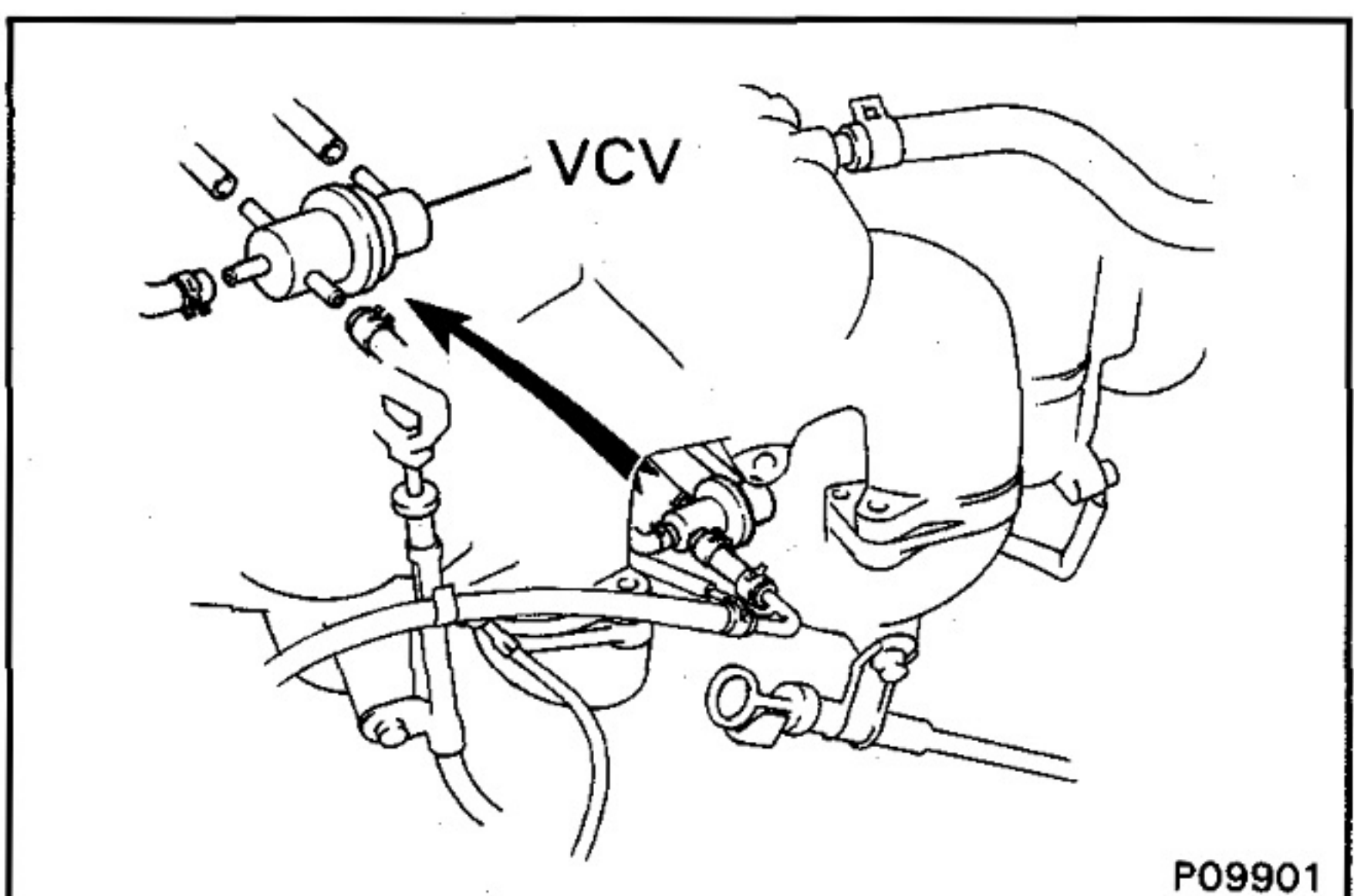

2. INSPECT VCV

- (a) Apply vacuum above 9.3 kPa (70 mmHg, 2.76 in.Hg) to pipe S.
- (b) Blow air into pipe Y and check that air comes out of pipe Z.

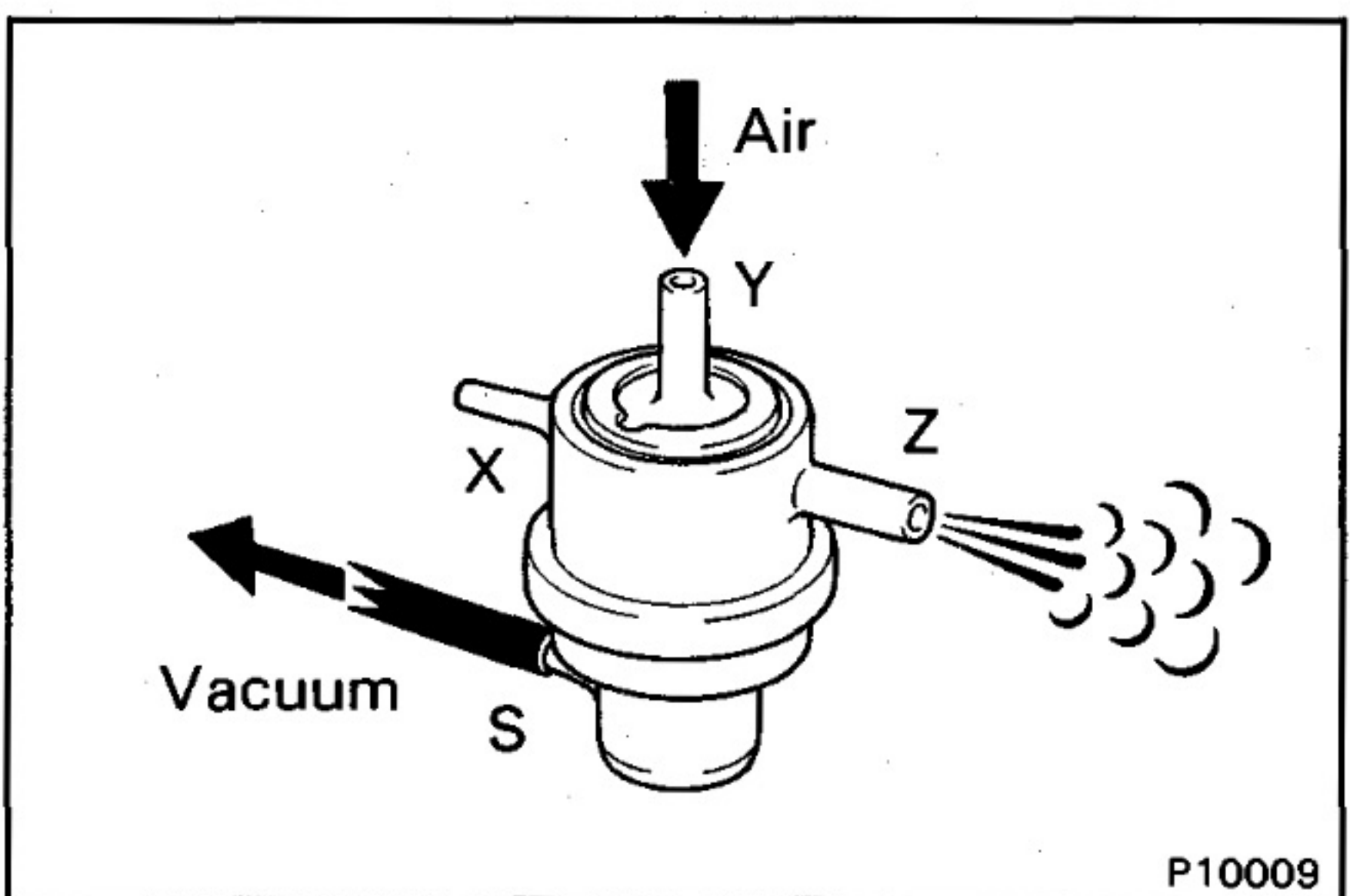

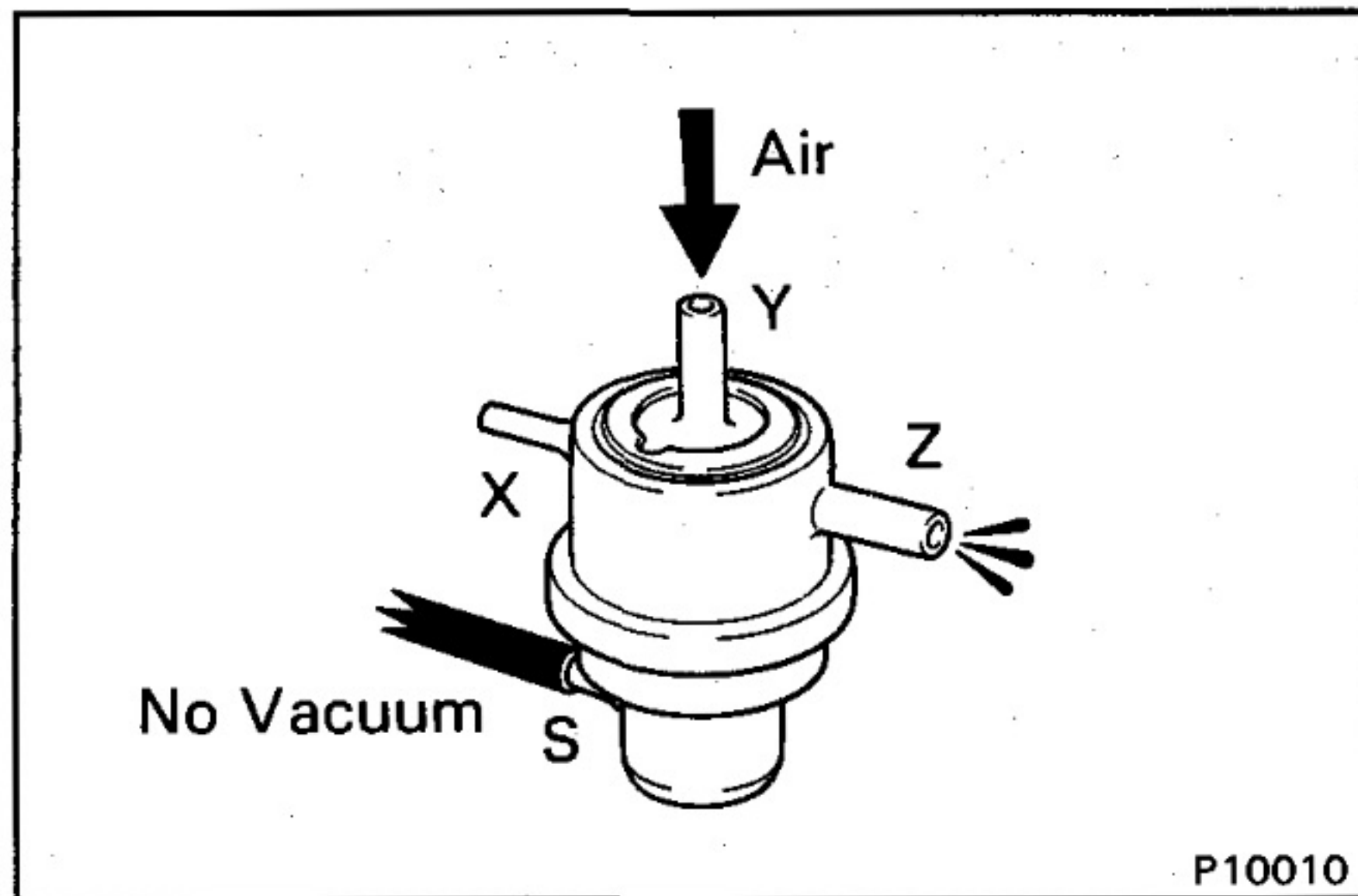

- (c) Stop the applied vacuum.
- (d) Blow air into pipe Y and check that air does not come out of pipe Z.

If operation is not as specified, replace the VCV.

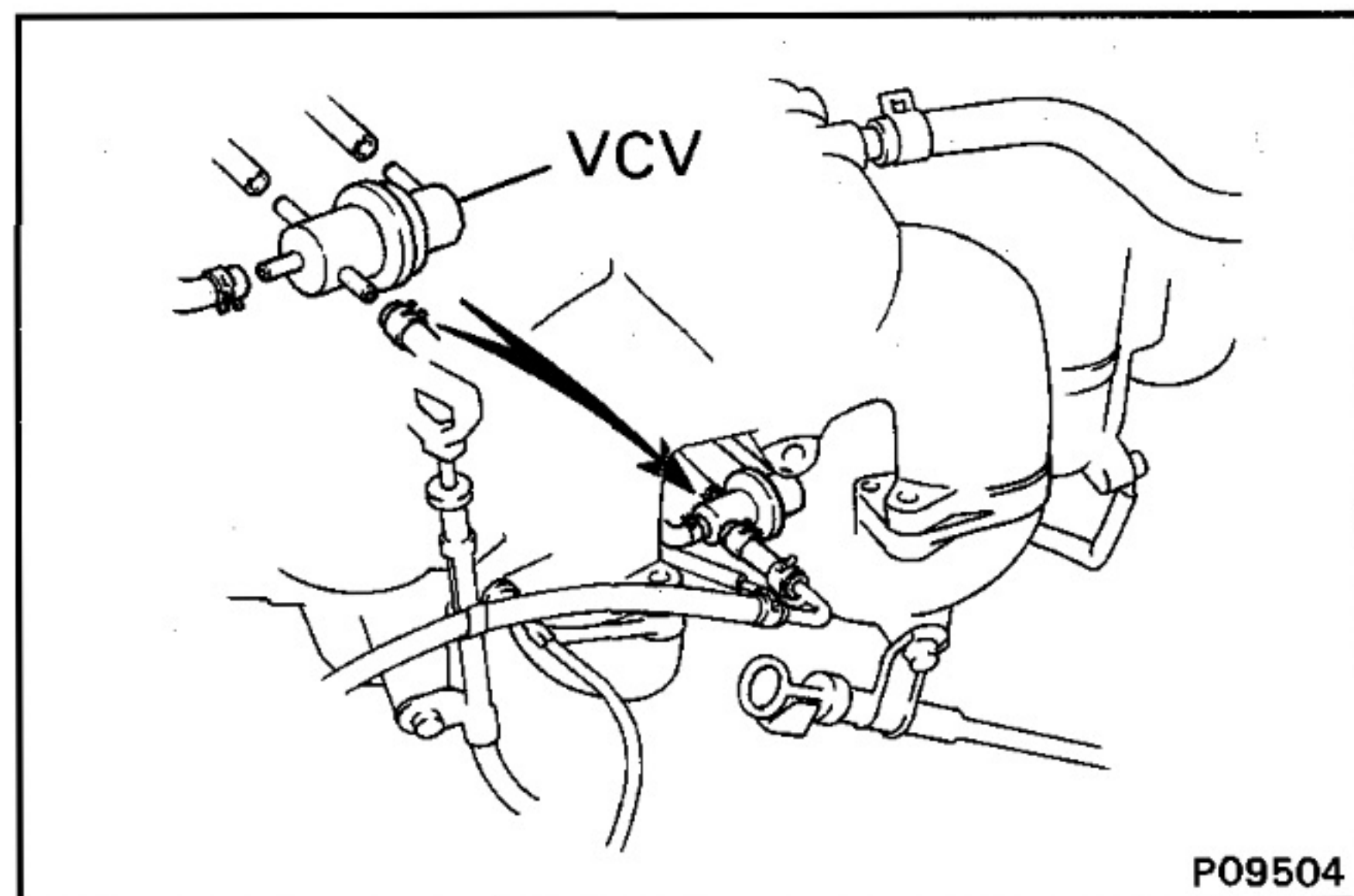

3. REINSTALL VCV

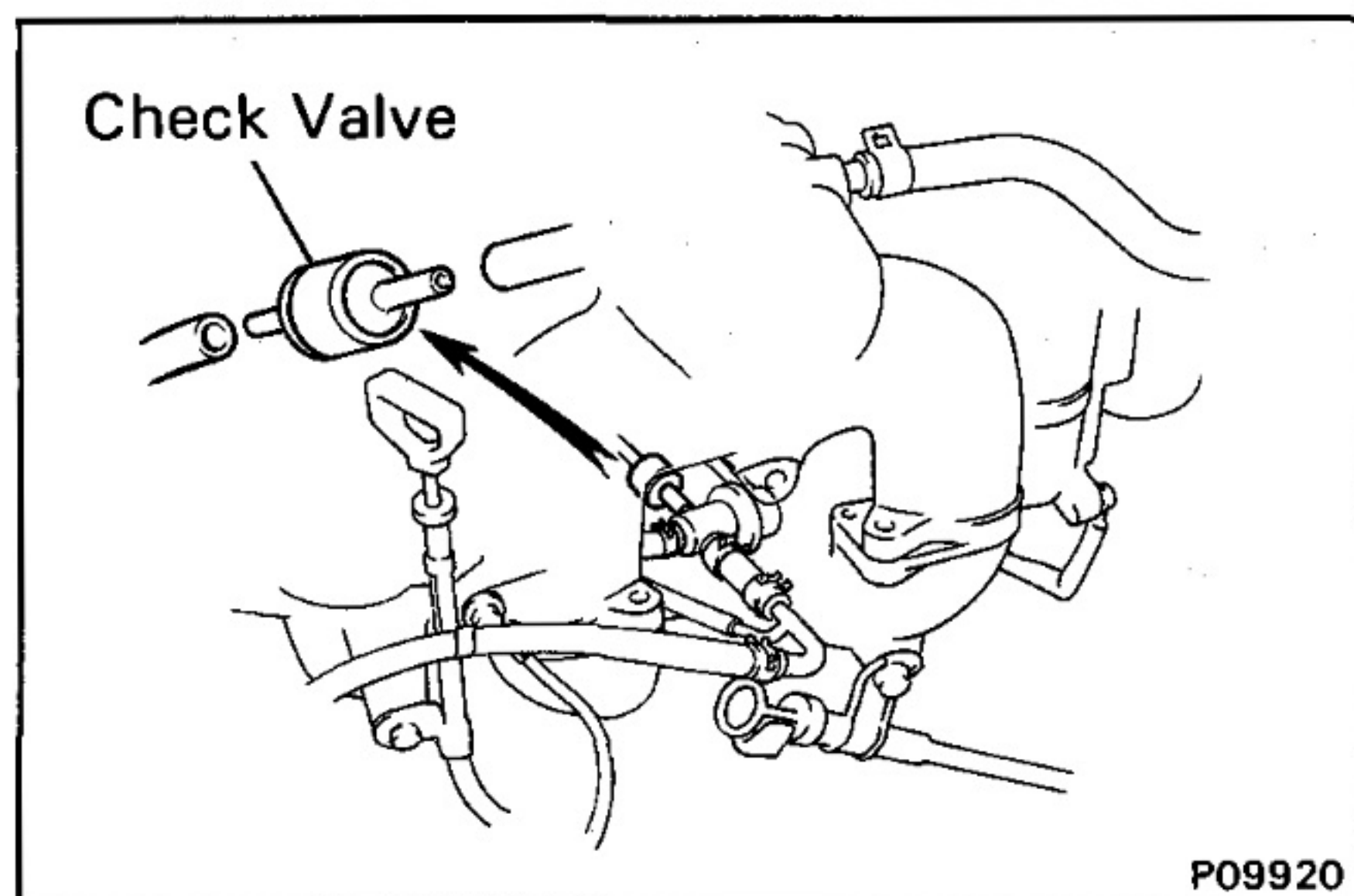

INSPECTION OF CHECK VALVE

1. REMOVE CHECK VALVE

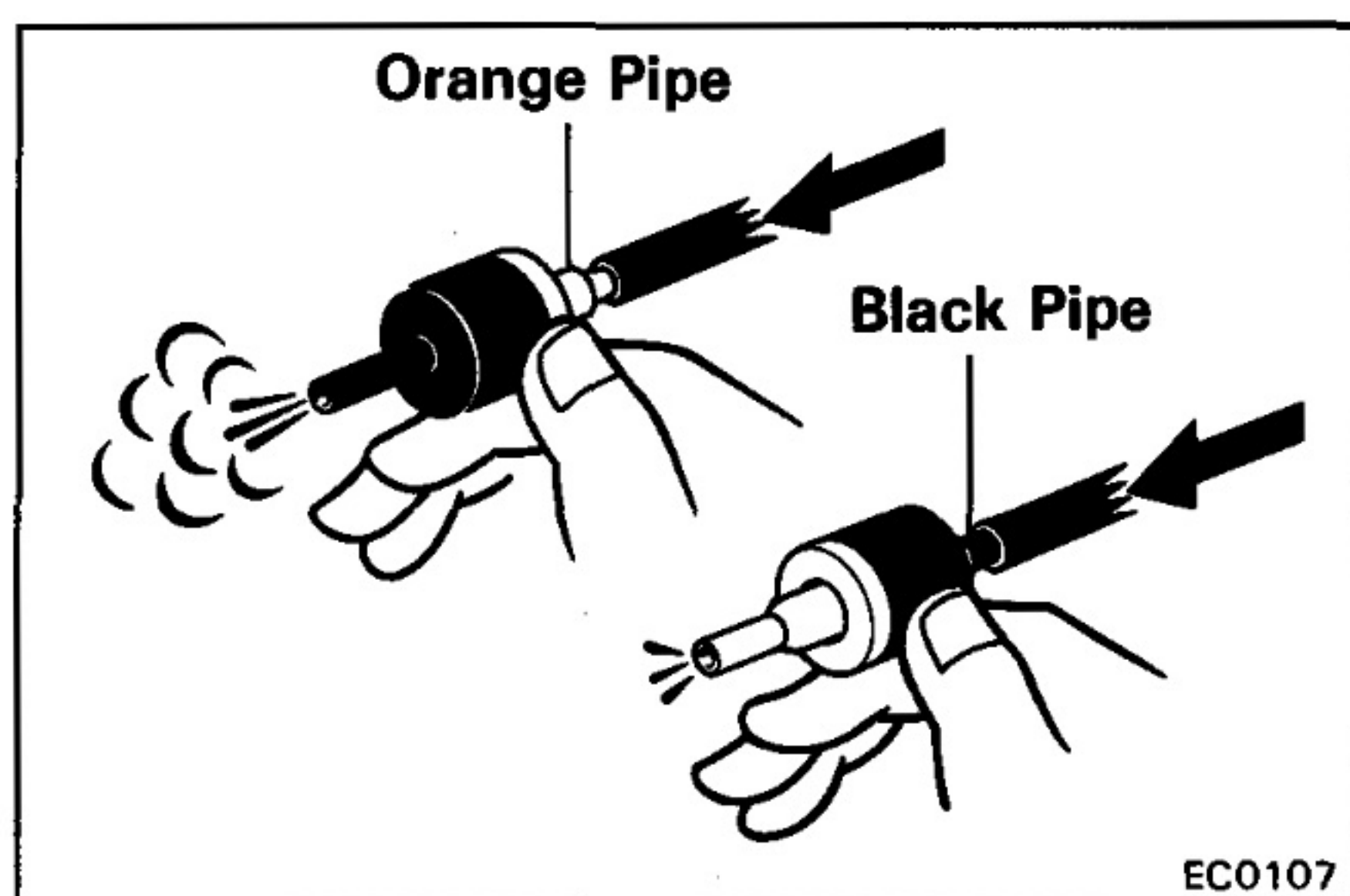

2. INSPECT CHECK VALVE

- (a) Check that air flows from the orange pipe to the black pipe.
- (b) Check that air does not flow from the black pipe to the orange pipe.

If operation is not as specified, replace the check valve.

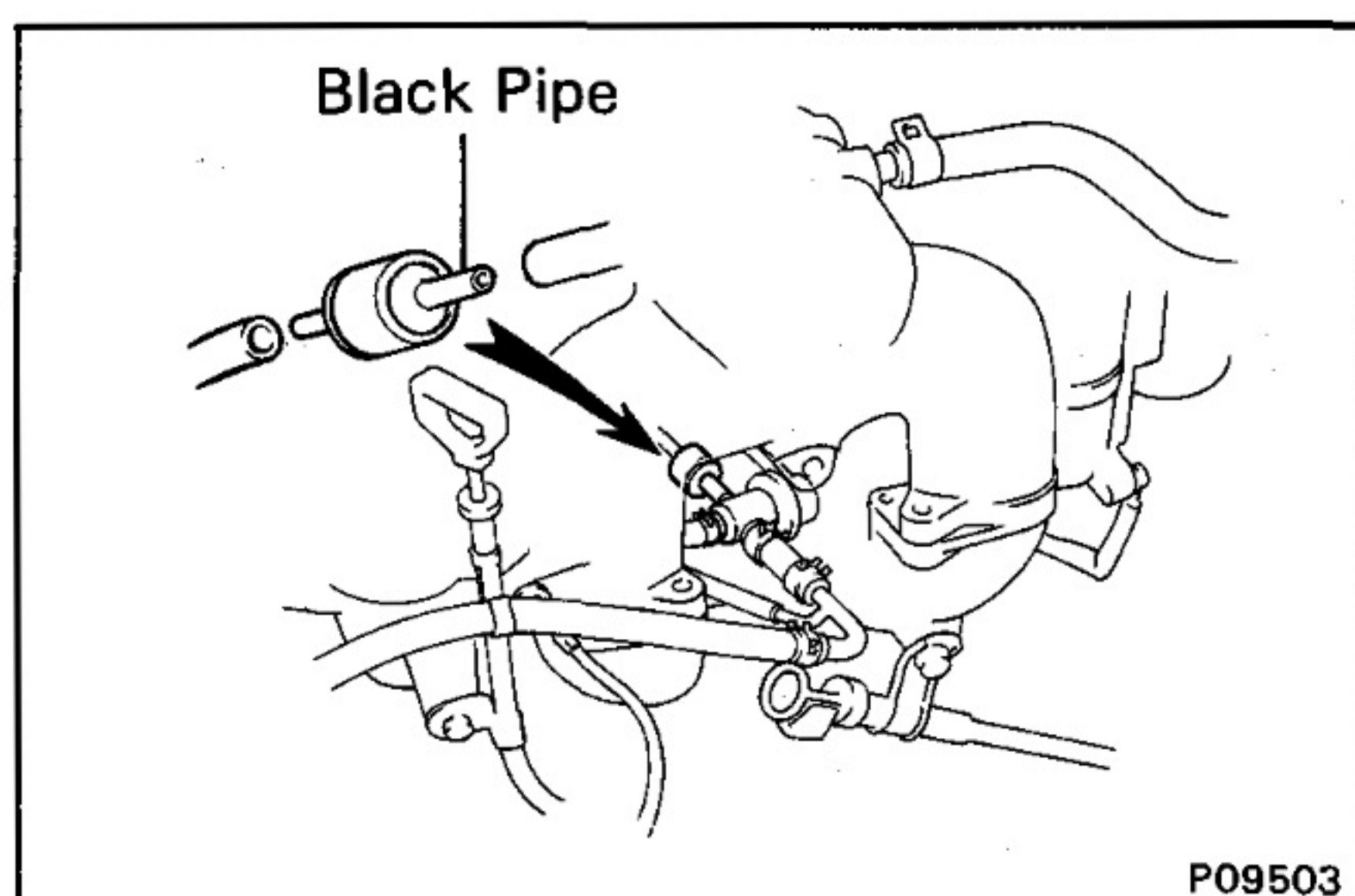

3. REINSTALL CHECK VALVE

HINT: Reinstall the check valve with the black pipe facing the VCV side.

EXHAUST GAS RECIRCULATION (EGR) SYSTEM

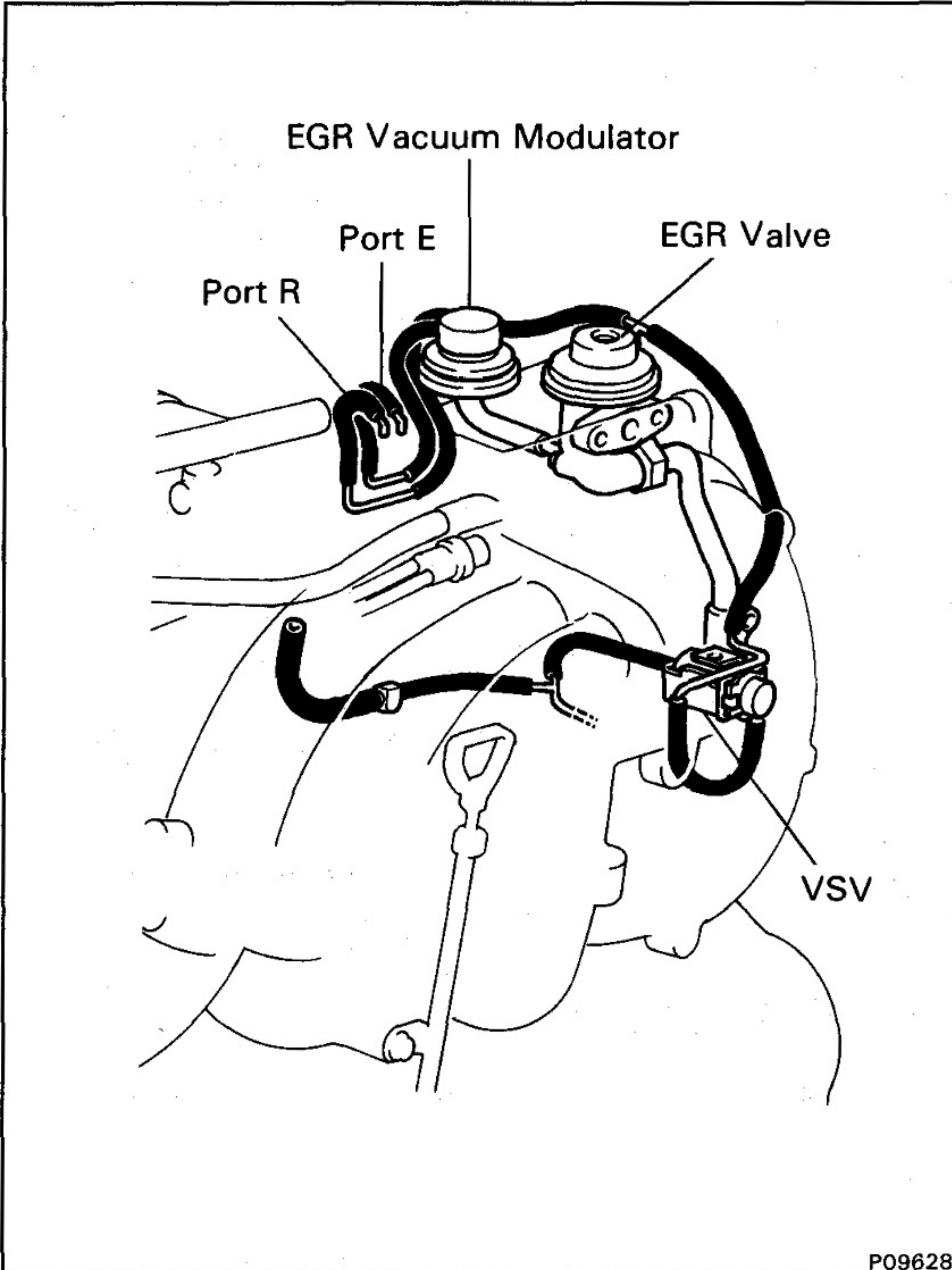

P09628

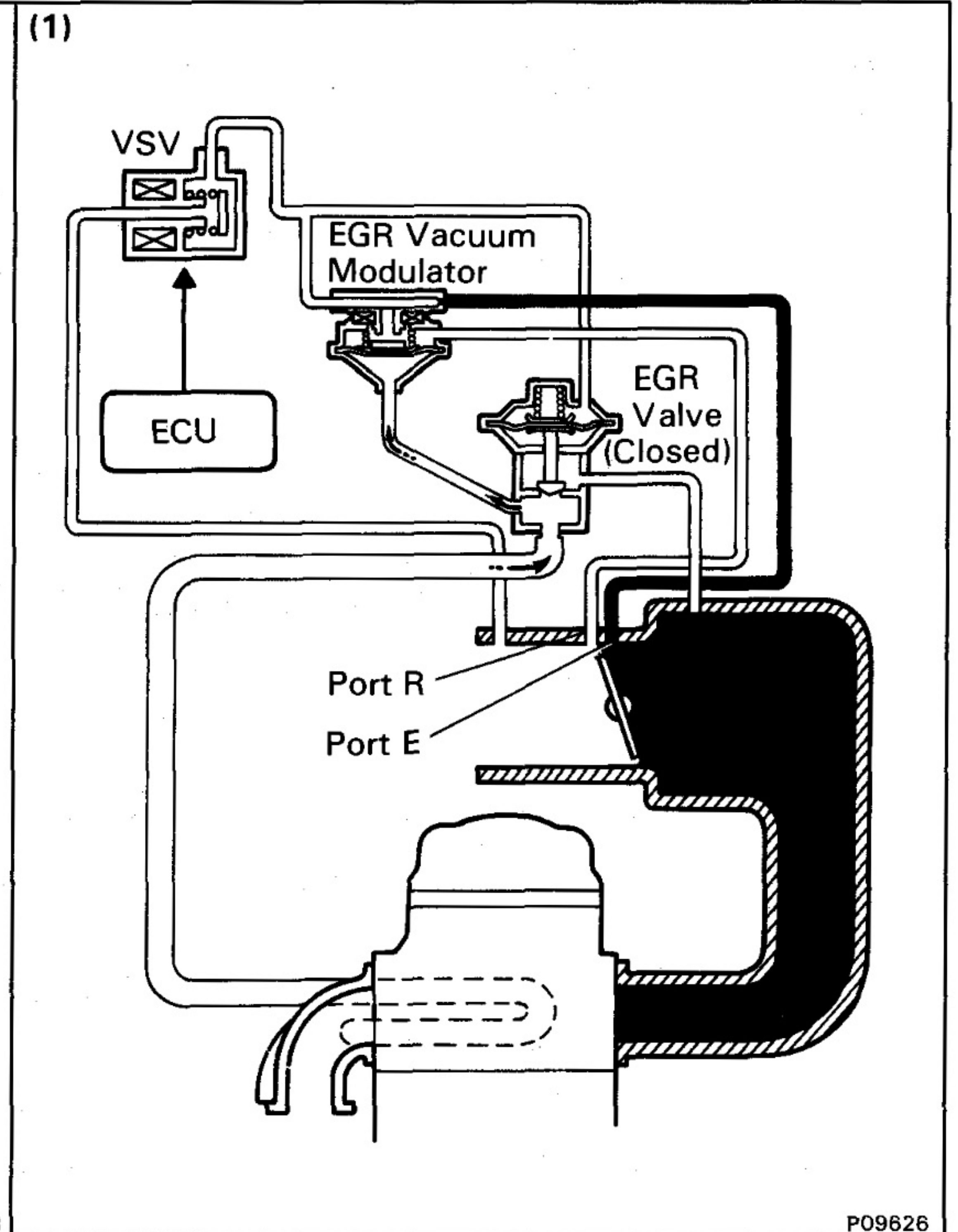

P09626

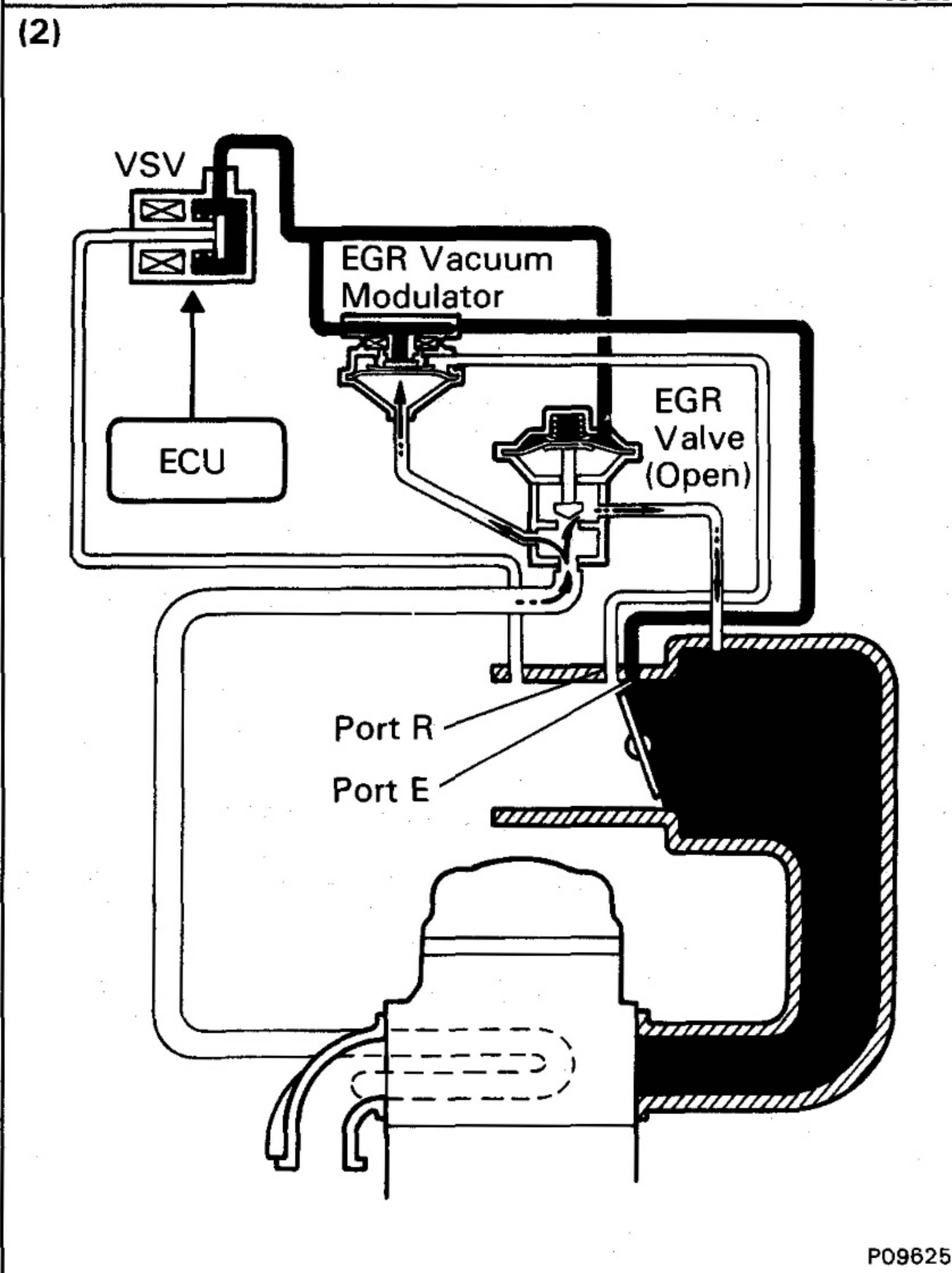

P09625

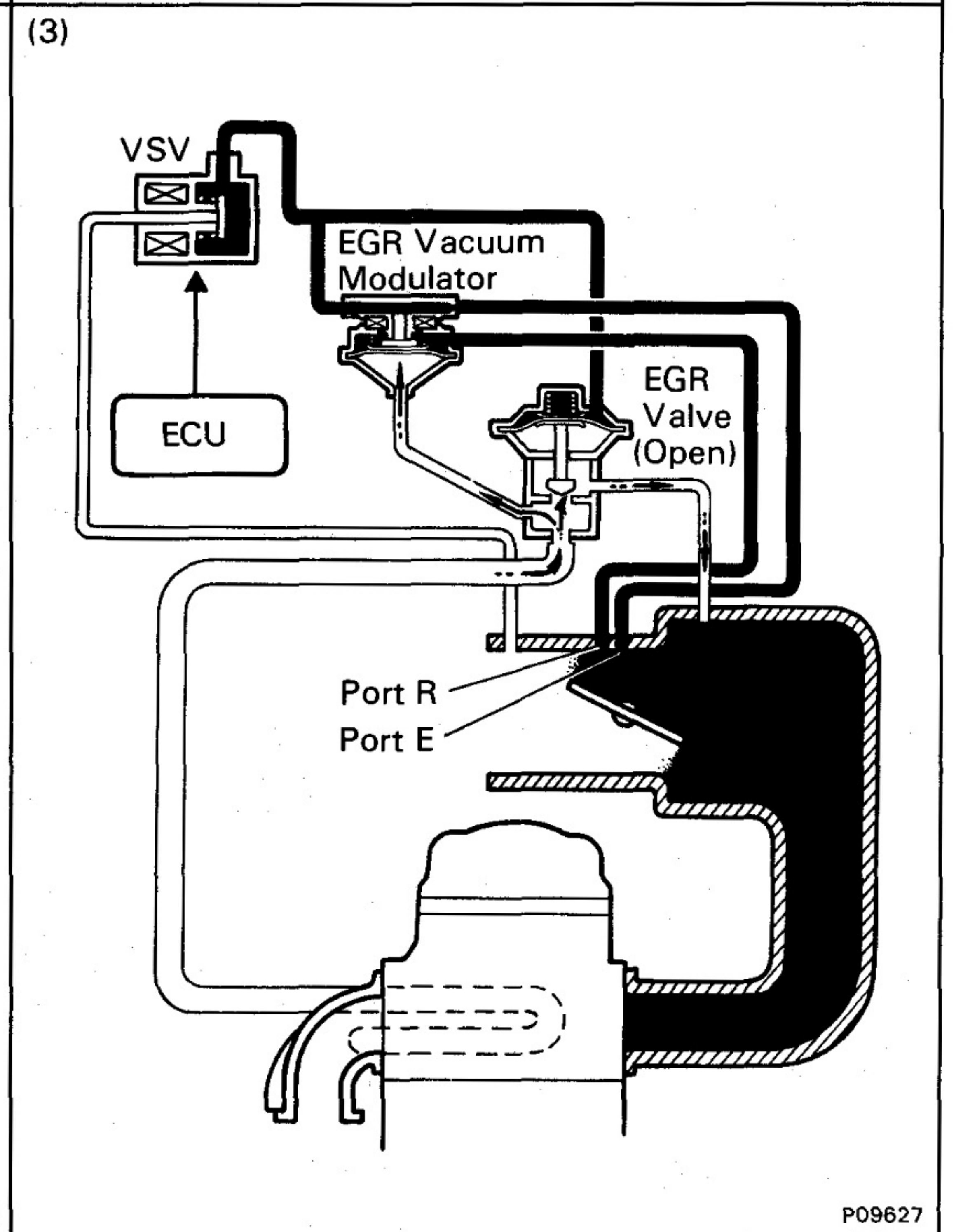

P09627

To reduce NO_x emission, part of the exhaust gases are recirculated through the EGR valve to the intake manifold to lower the maximum combustion temperature.

Engine Coolant Temp.	RPM	Driving Condition	Intake Air Volume	VSV	Throttle Position	Pressure in the EGR Valve Pressure Chamber	EGR Vacuum Modulator	EGR Valve	Exhaust Gas	
Below 47 °C (117 °F)	—	—	—	OFF	—	—	—	CLOSED	Not recirculated	
Above 53°C (127°F)	Above 3,500 rpm	—	—	OFF	—	—	—	CLOSED	Not recirculated	
	Below 3,500 rpm	Deceleration	—	OFF	—	—	—	CLOSED	Not recirculated	
		Ex. deceleration	HIGH	OFF	—	—	—	—	CLOSED	Not recirculated
			NORMAL	ON	Below port E	—	—	—	CLOSED	Not recirculated
					Between port E and port R	(1) LOW	*Pressure constantly alternating between low and high	OPENS passage to atmosphere	CLOSED	Not recirculated
(2) HIGH		CLOSES passage to atmosphere	OPEN	Recirculated						
Above port R	(3) HIGH	**	CLOSES passage to atmosphere	OPEN	Recirculated (increase)					

*Pressure increase → Modulator closes → EGR valve opens → Pressure drops
 ← EGR valve closes ← Modulator opens ←

**When the throttle valve is positioned above the R port, the EGR vacuum modulator will close the atmosphere passage and open the EGR valve to increase the EGR gas, even if the exhaust pressure is insufficiently low.

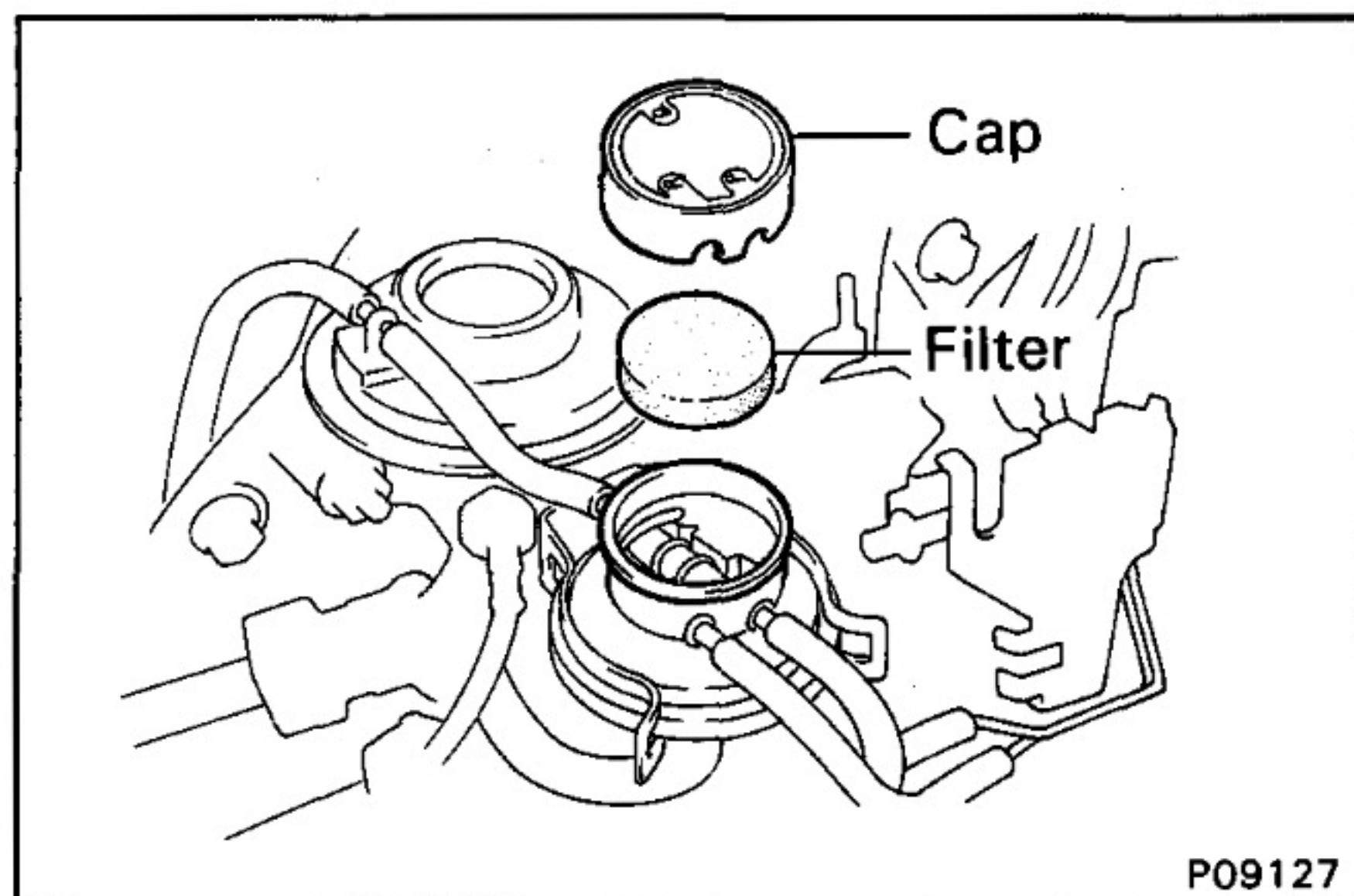

INSPECTION OF EGR SYSTEM

1. INSPECT AND CLEAN FILTER IN EGR VACUUM MODULATOR

- Remove the cap and filter.
- Check the filter for contamination or damage.
- Using compressed air, clean the filter.
- Reinstall the filter and cap.

HINT: Install the filter with the coarser surface facing the atmospheric side (outward).

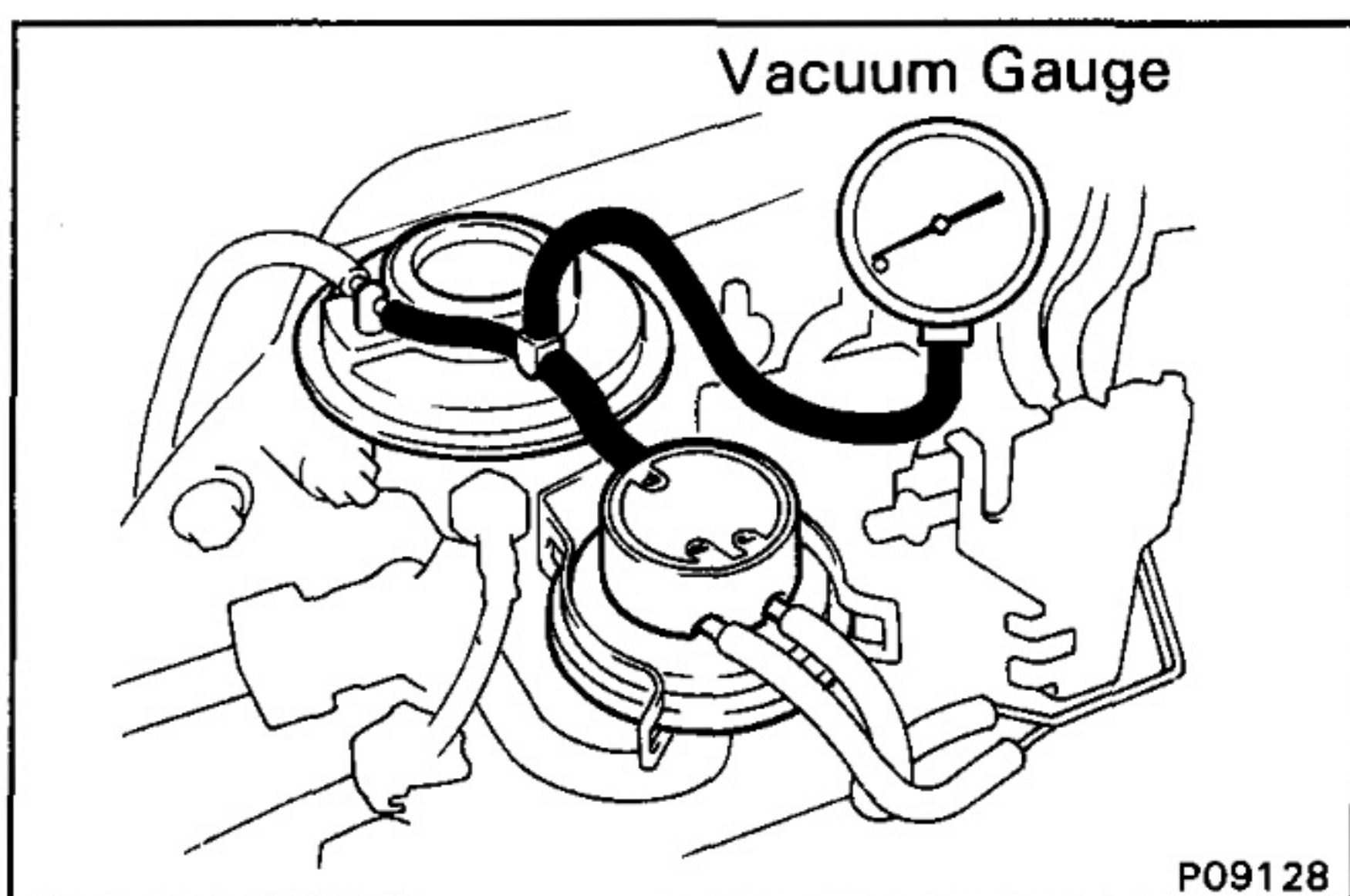

2. INSTALL VACUUM GAUGE

Using a 3-way connector, connect a vacuum gauge to the hose between the EGR valve and EGR vacuum modulator.

3. INSPECT SEATING OF EGR VALVE

Start the engine and check that the engine starts and runs at idle.

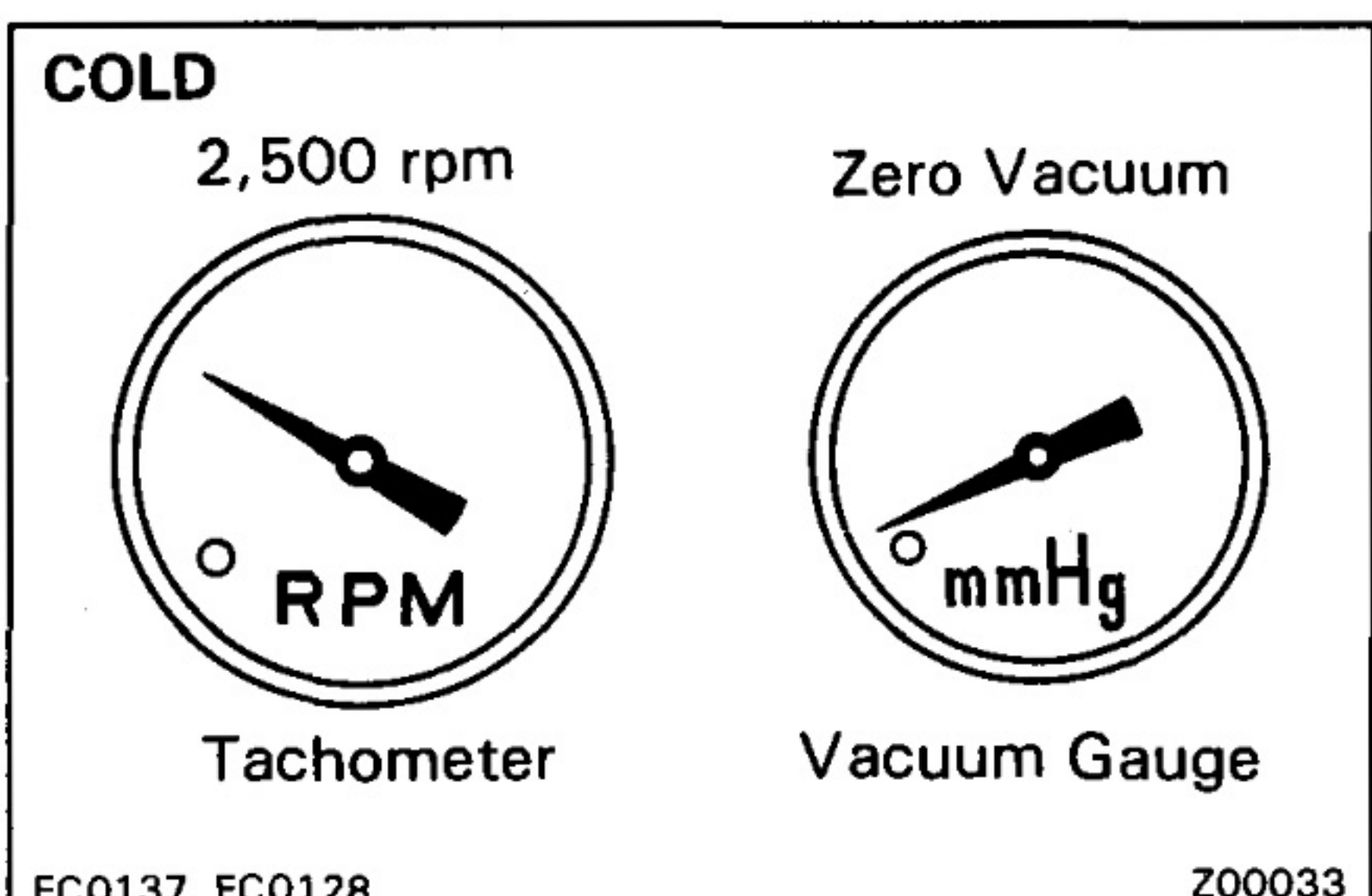

4. INSPECT VSV OPERATION WITH COLD ENGINE

- The engine coolant temperature should be below 47°C (117°F).
- Check that the vacuum gauge indicates zero at 2,500 rpm.

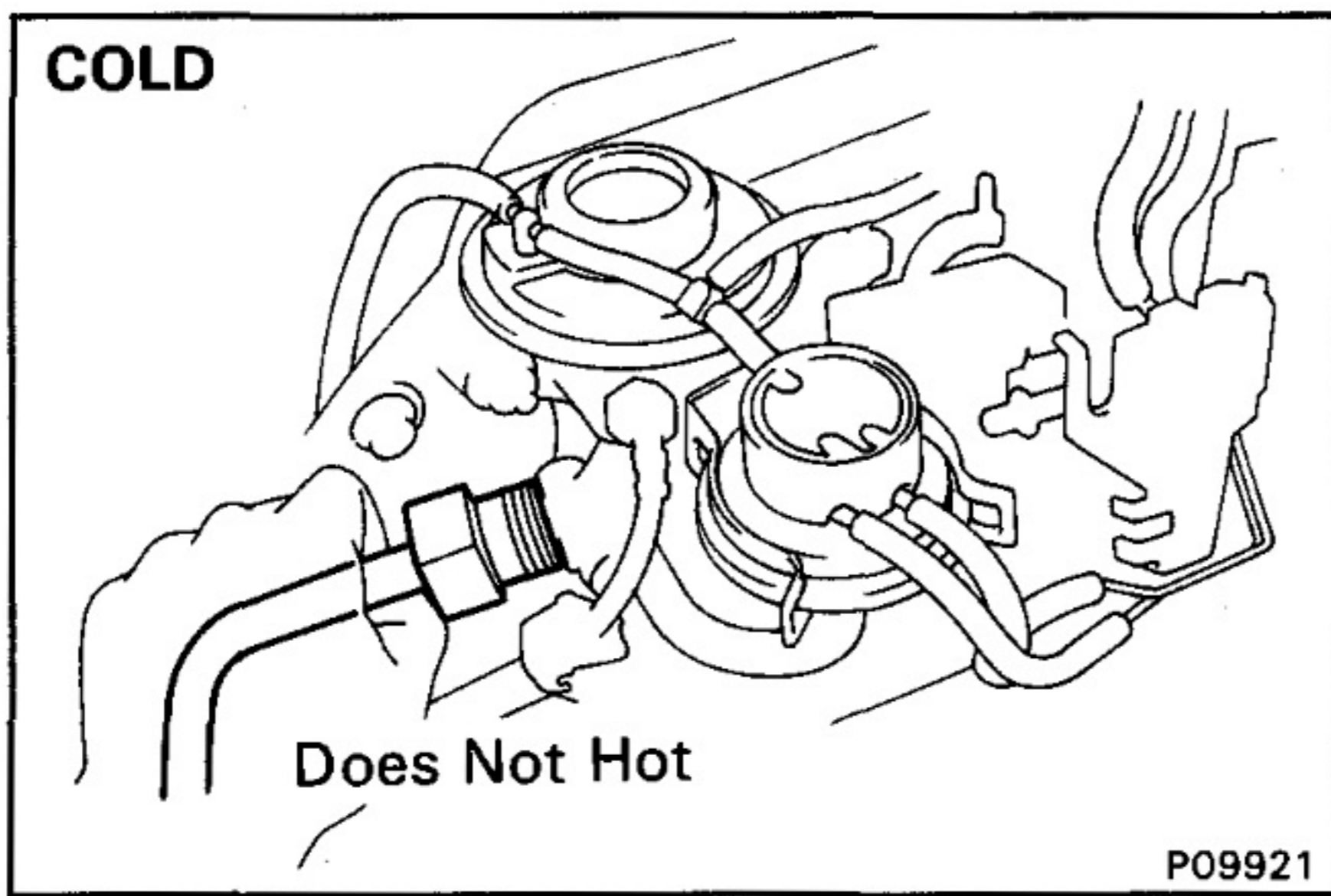

(c) Check that the EGR pipe is not hot.

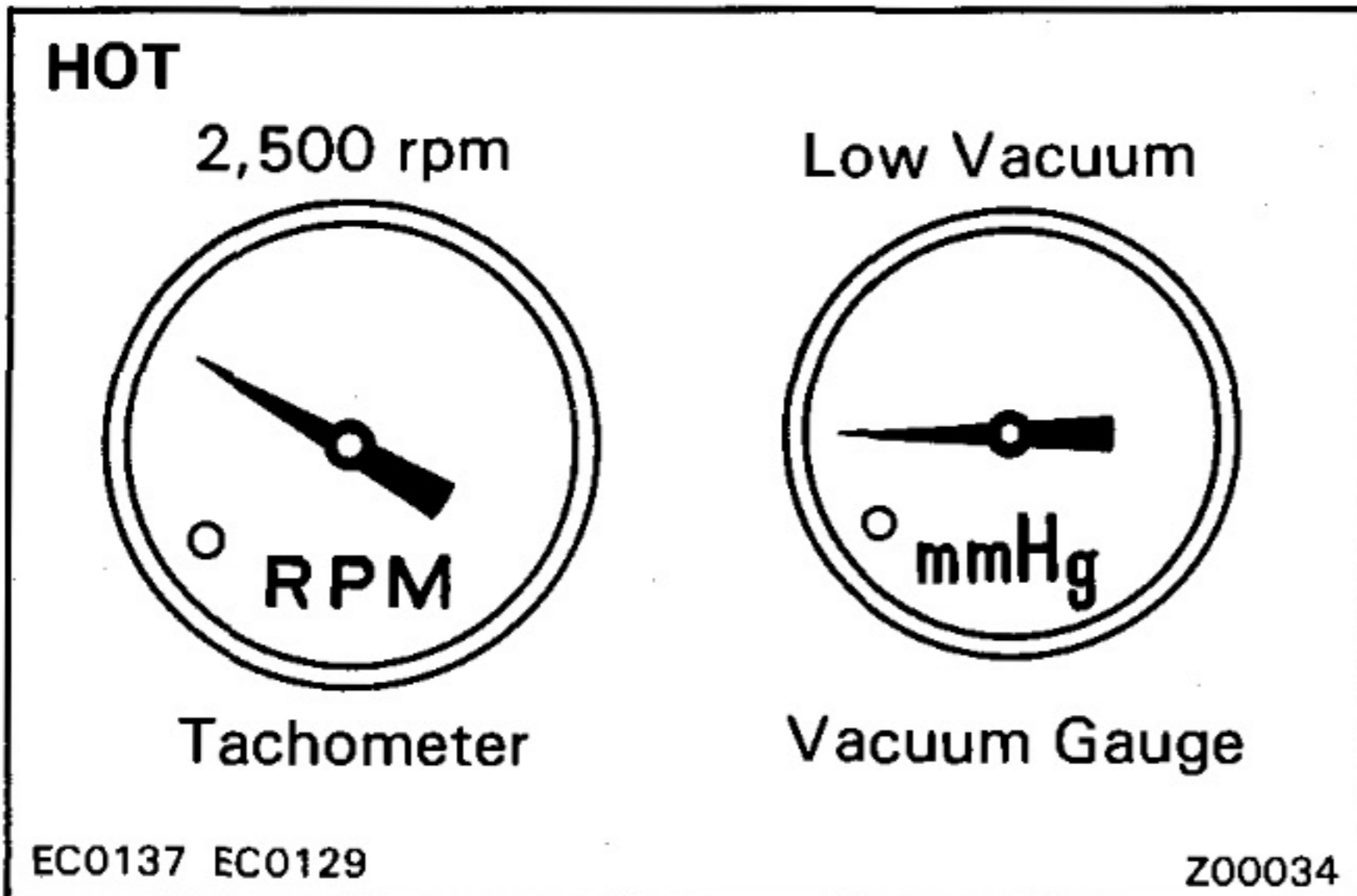

5. INSPECT OPERATION OF VSV AND EGR VACUUM MODULATOR WITH HOT ENGINE

- (a) Warm up the engine to above 53°C (127°F).
- (b) Check that the vacuum gauge indicates low vacuum at 2,500 rpm.

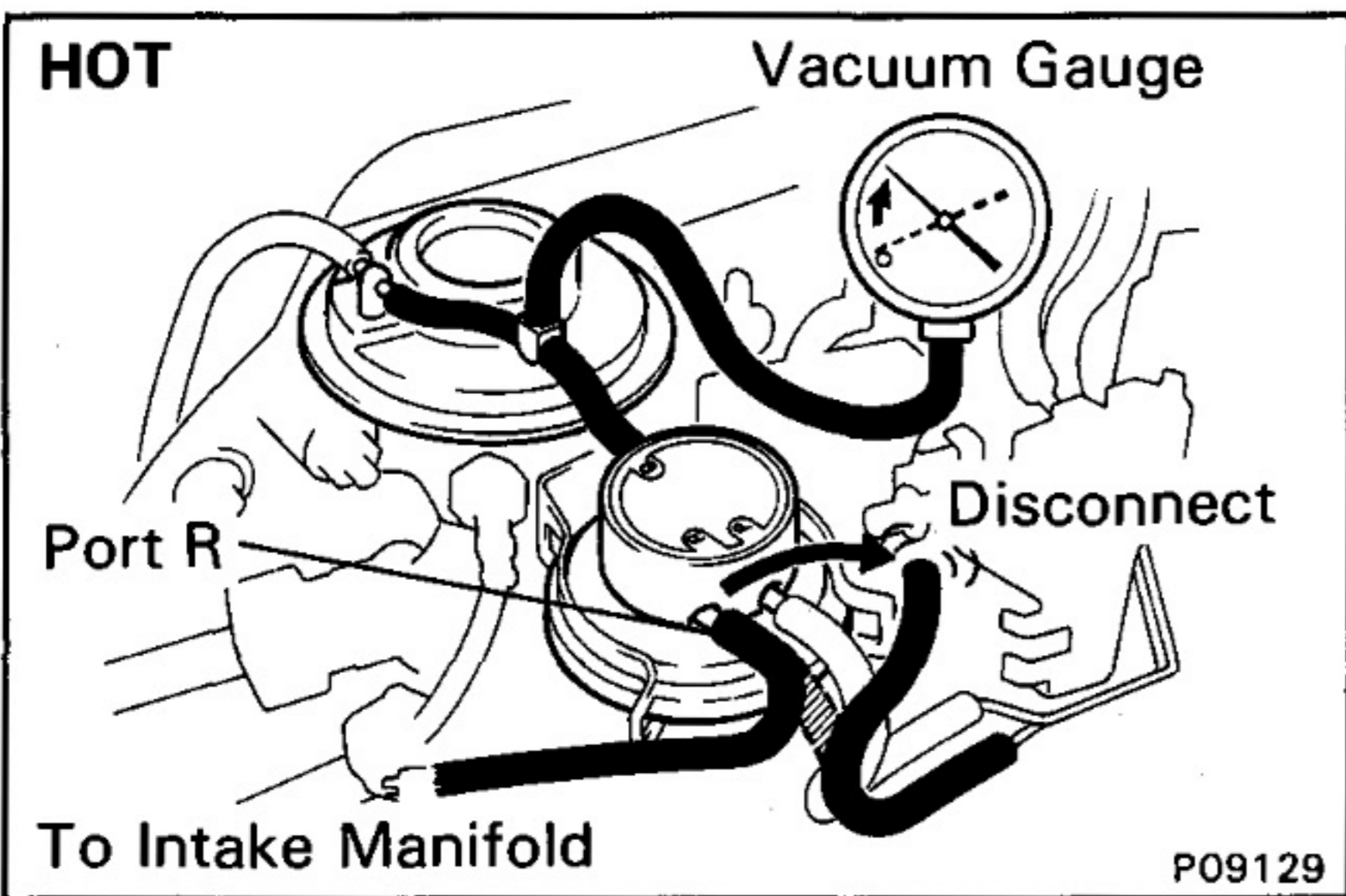

- (c) Disconnect the vacuum hose port R of the EGR vacuum modulator and connect port R directly to the intake manifold with another hose.
- (d) Check that the vacuum gauge indicates high vacuum at 2,500 rpm.

HINT: As a large amount of exhaust gas enters, the engine will misfire slightly.

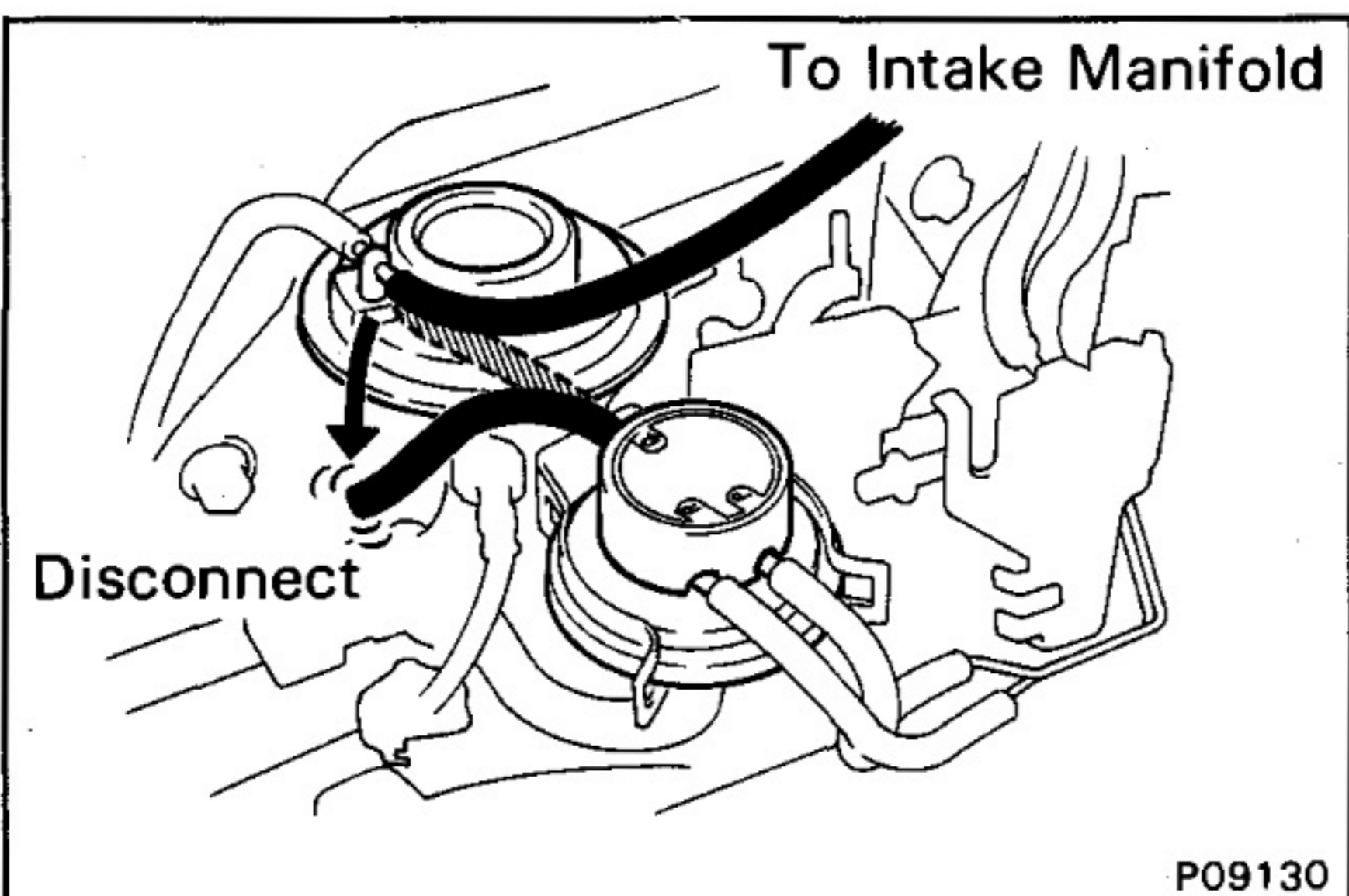

6. REMOVE VACUUM GAUGE

Remove the vacuum gauge, and reconnect the vacuum hoses to the proper locations.

7. INSPECT EGR VALVE

- (a) Apply vacuum directly to the EGR valve with the engine idling.
- (b) Check that the engine runs rough or dies.

- (c) Reconnect the vacuum hoses to the proper locations.
- If you detect a problem when doing the above inspection, inspect each part.

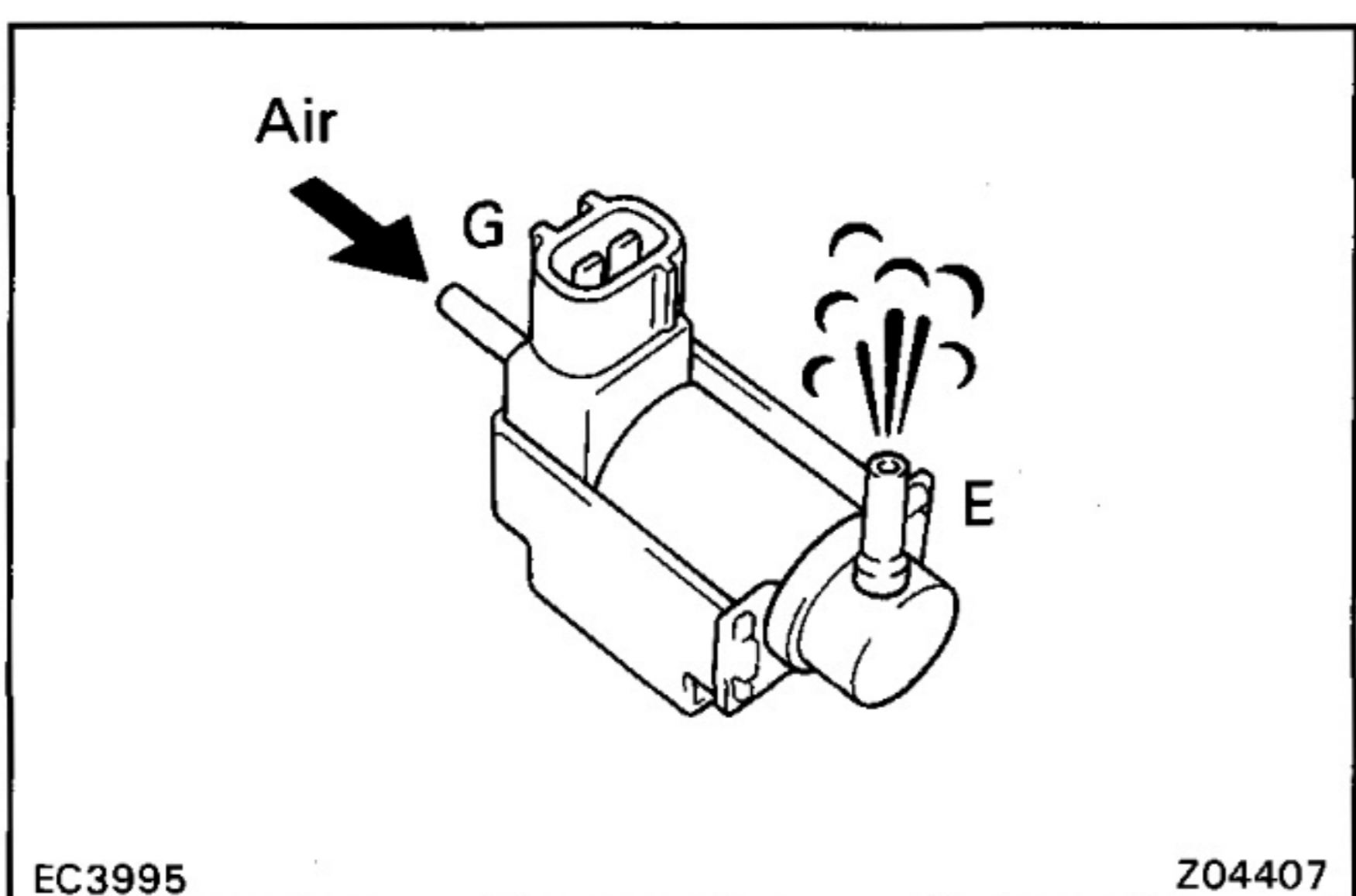
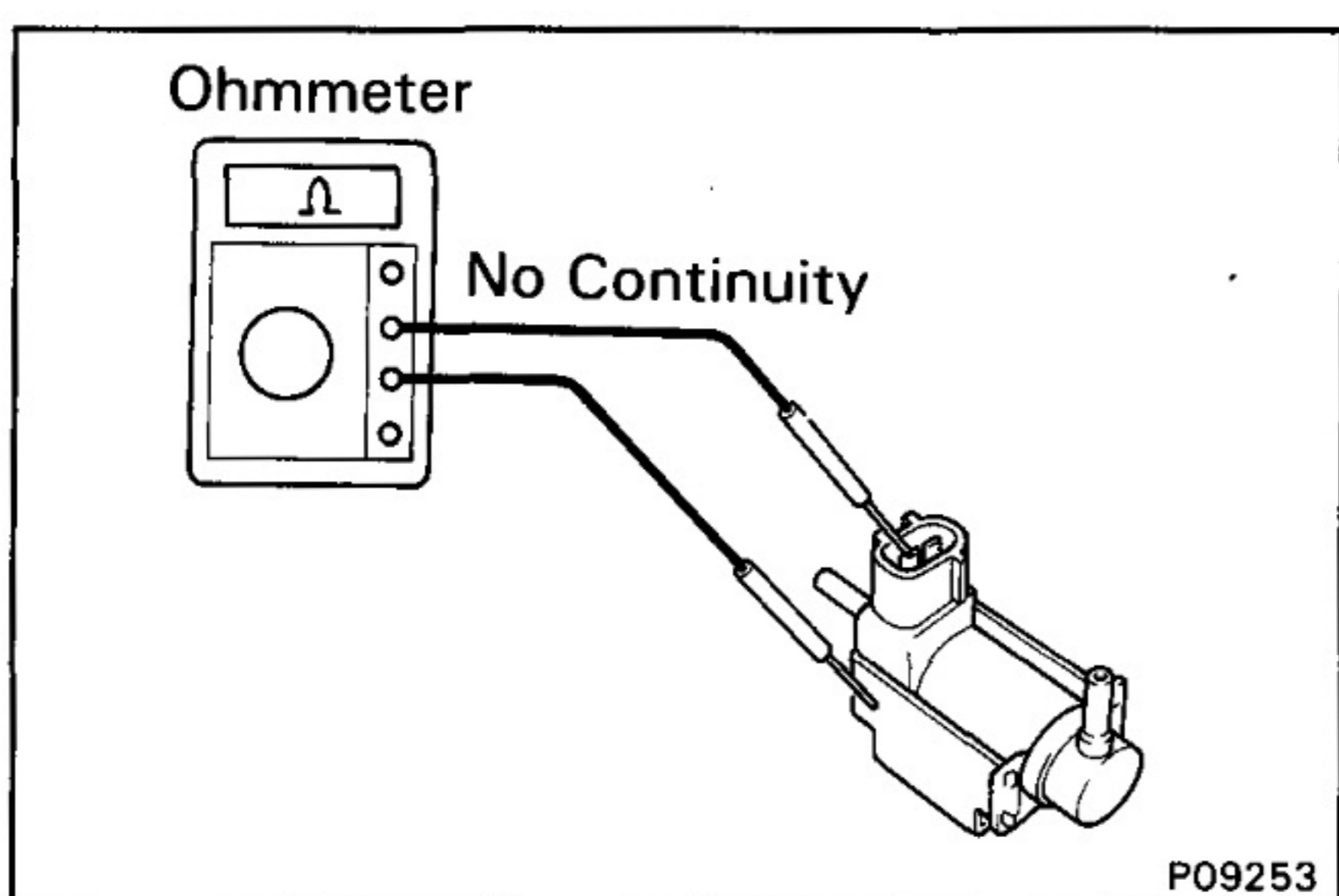
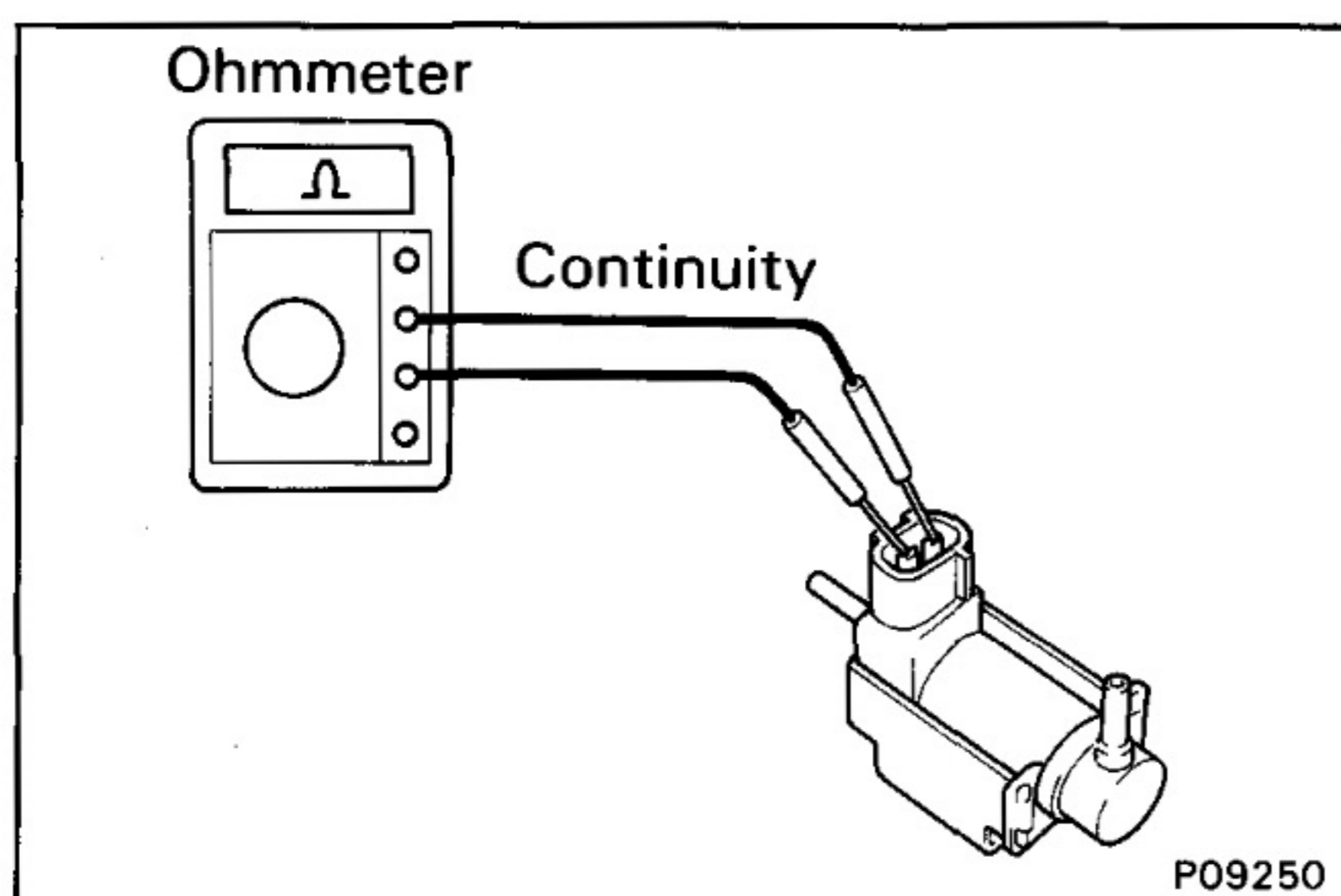
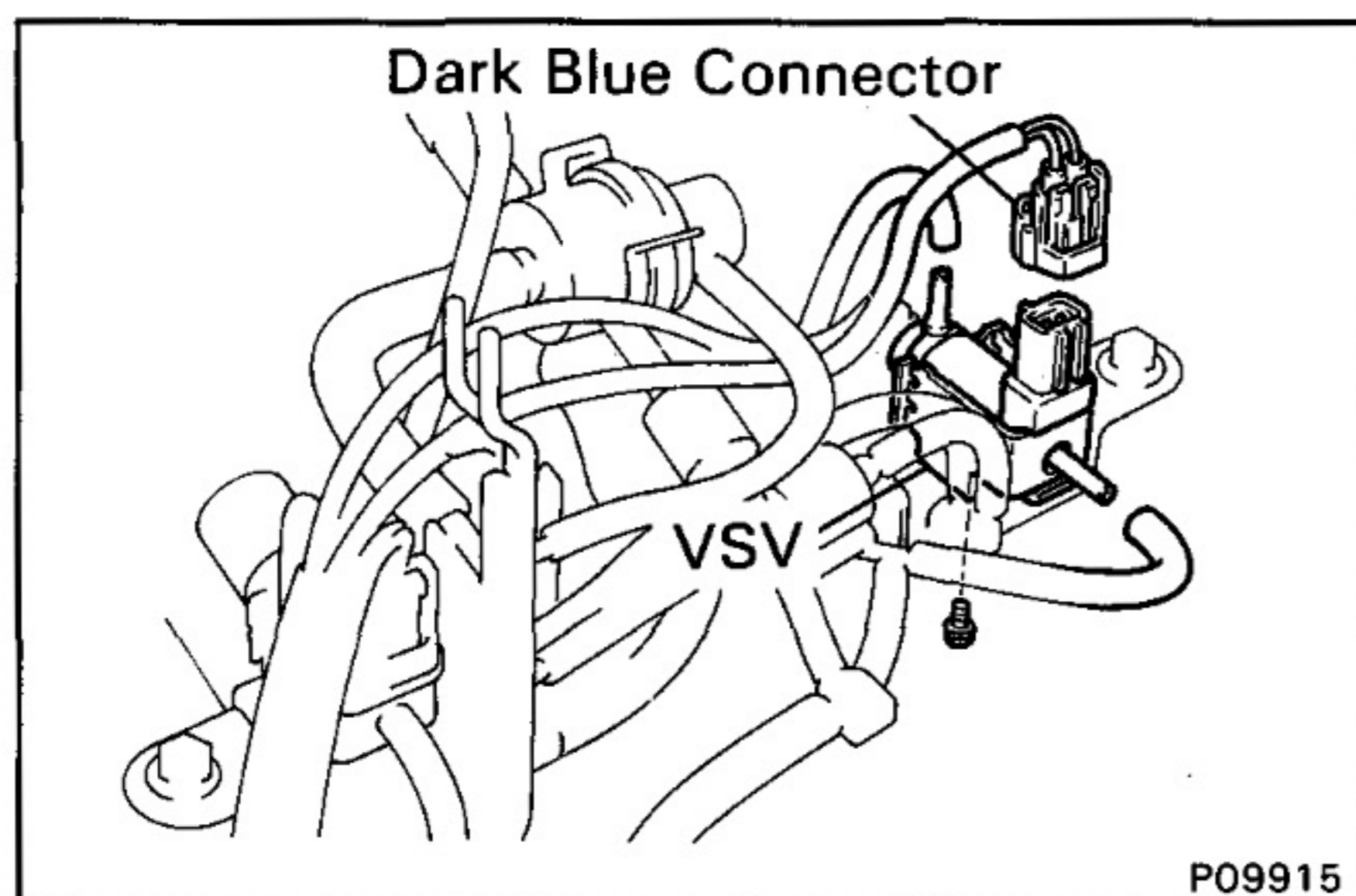
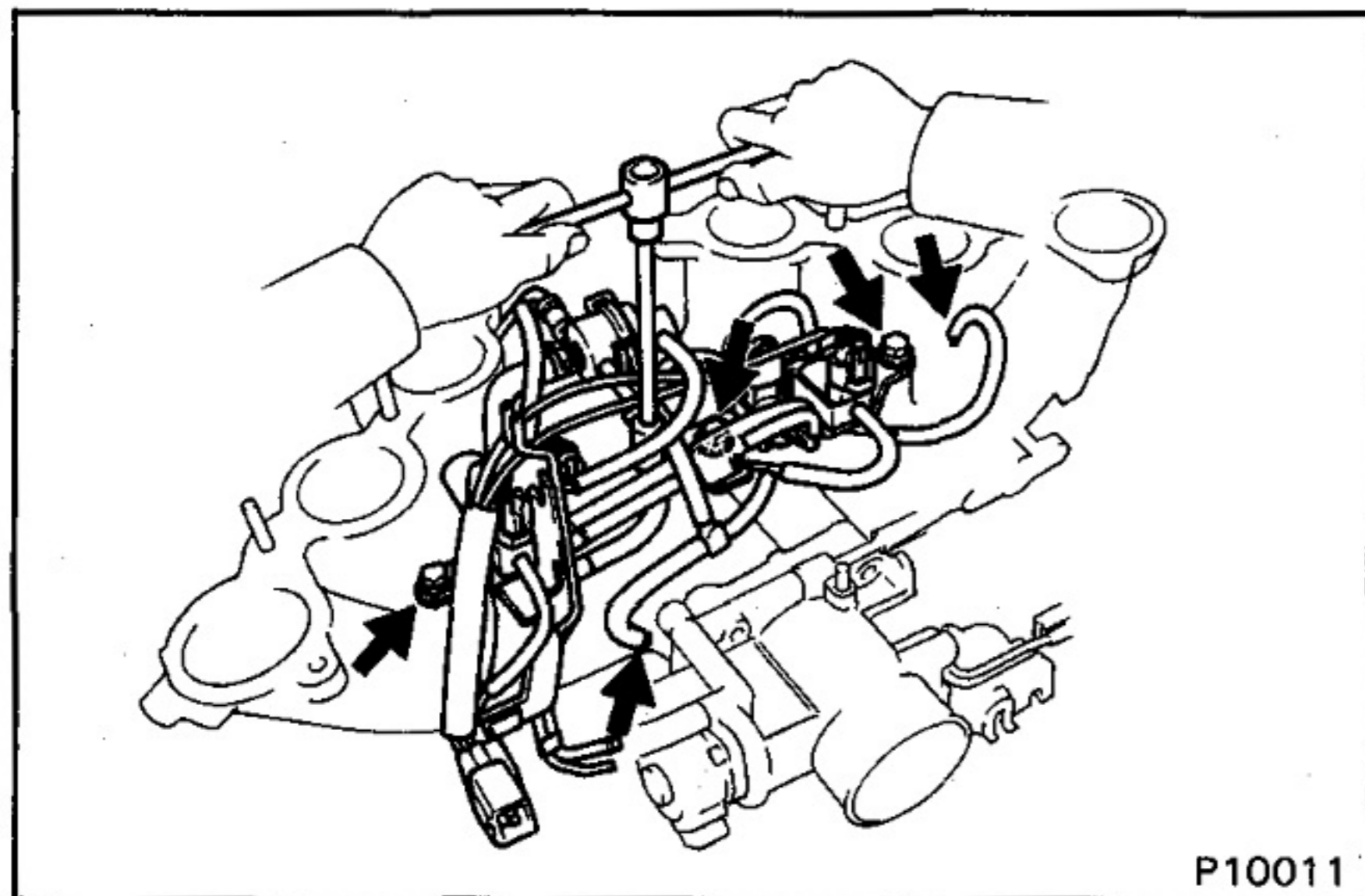

INSPECTION OF VSV

1. REMOVE AIR INTAKE CHAMBER

2. REMOVE VSV

- (a) Disconnect the air hose and vacuum hose from the air intake chamber.
- (b) Remove the four bolts and emission control valve set assembly.
- (c) Disconnect the connector and two vacuum hoses, and remove the screw and VSV.

3. INSPECT VSV

A. Inspect VSV for open circuit

Using an ohmmeter, check that there is continuity between the terminals.

Resistance:

30 – 34 Ω at 20°C (68°F)

If there is no continuity, replace the VSV.

B. Inspect VSV for ground

Using an ohmmeter, check that there is no continuity between each terminal and the body.

If there is continuity, replace the VSV.

C. Inspect VSV operation

- (a) Check that the air flows from pipe G to pipe E.

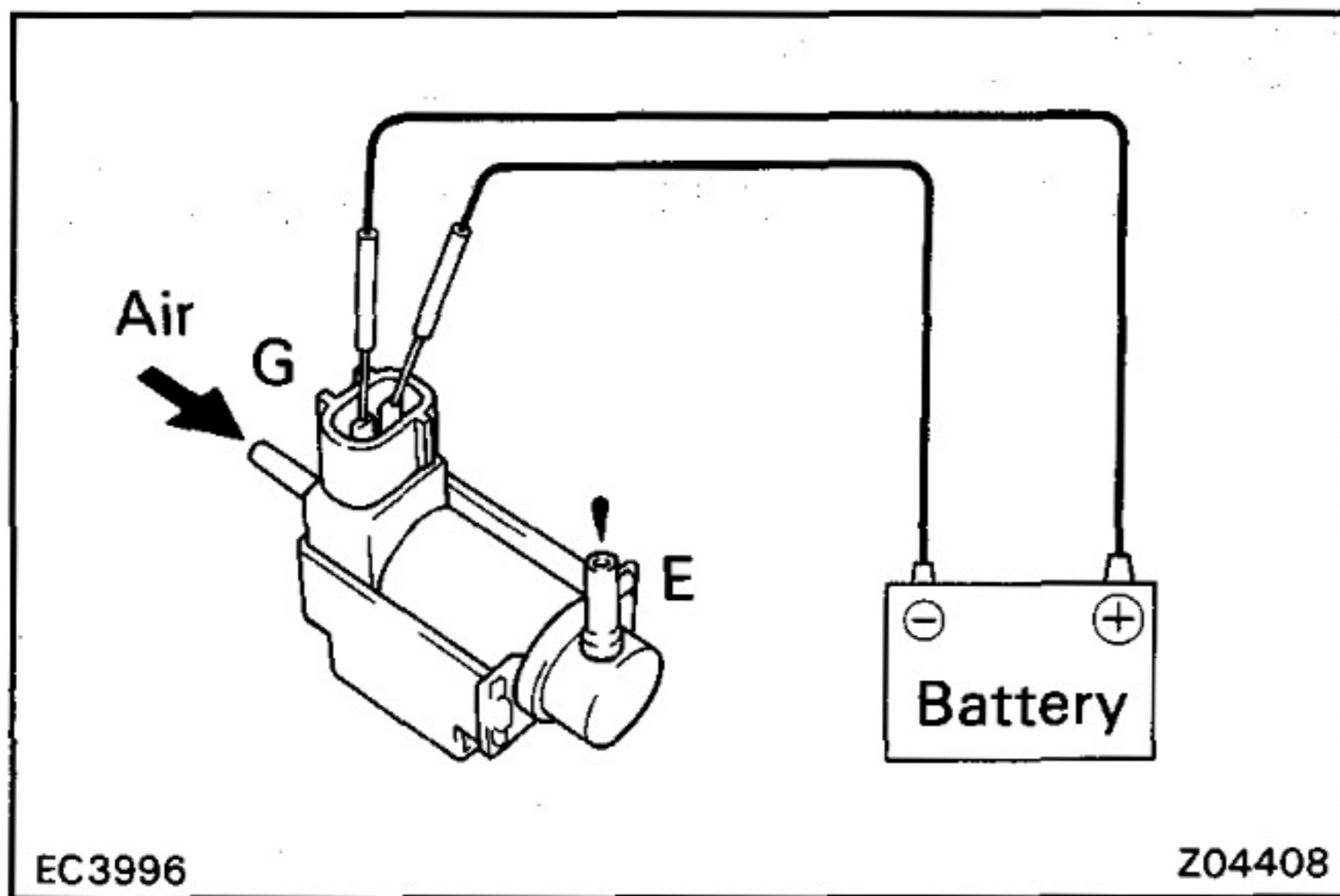

- (b) Apply battery voltage across the terminals.
- (c) Check that the air does not flow from pipe G to pipe E. If operation is not as specified, replace the VSV.

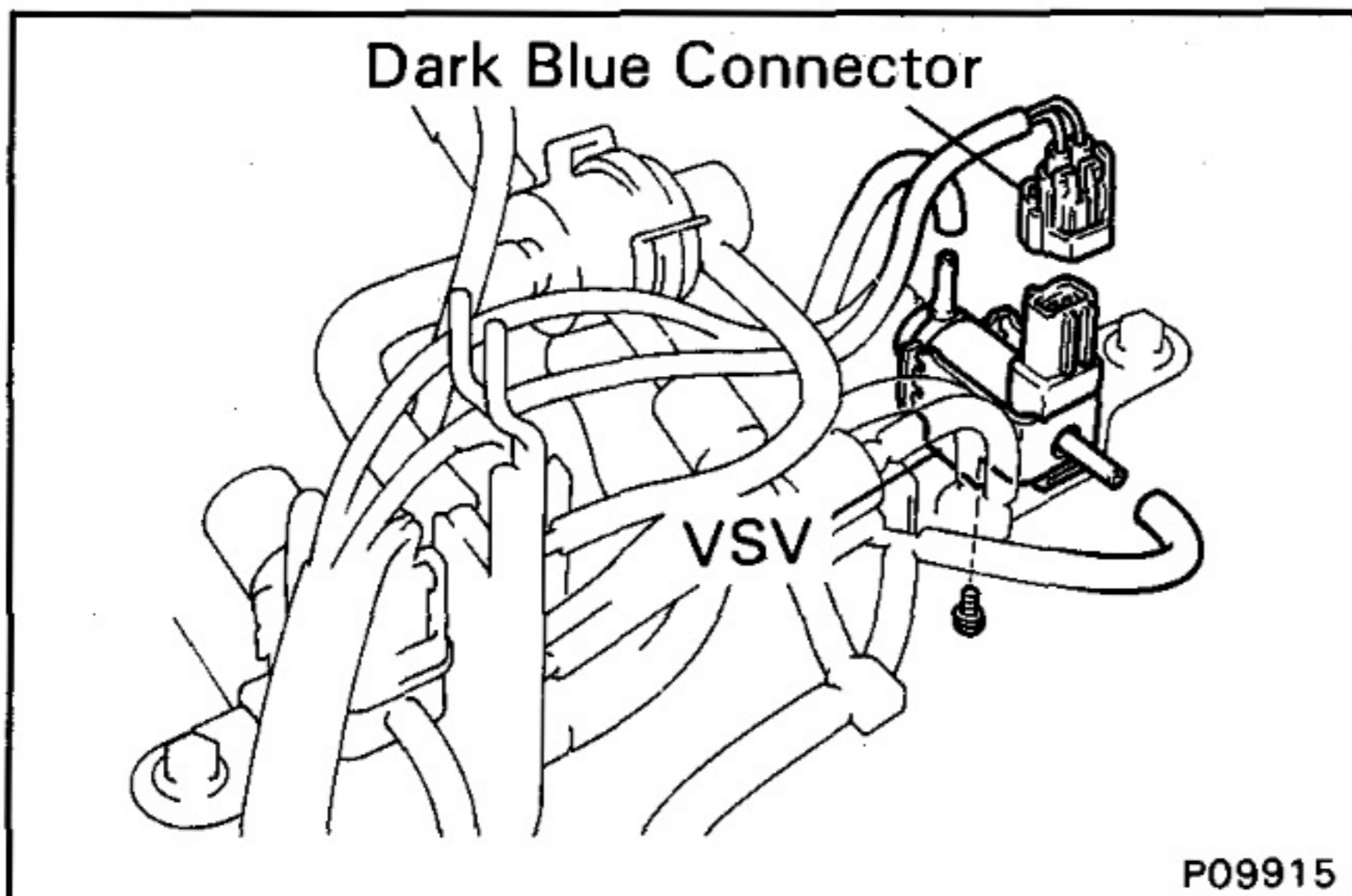

4. REINSTALL VSV

- (a) Install the VSV with the screws.
- (b) Connect the connector and two vacuum hoses to the VSV.

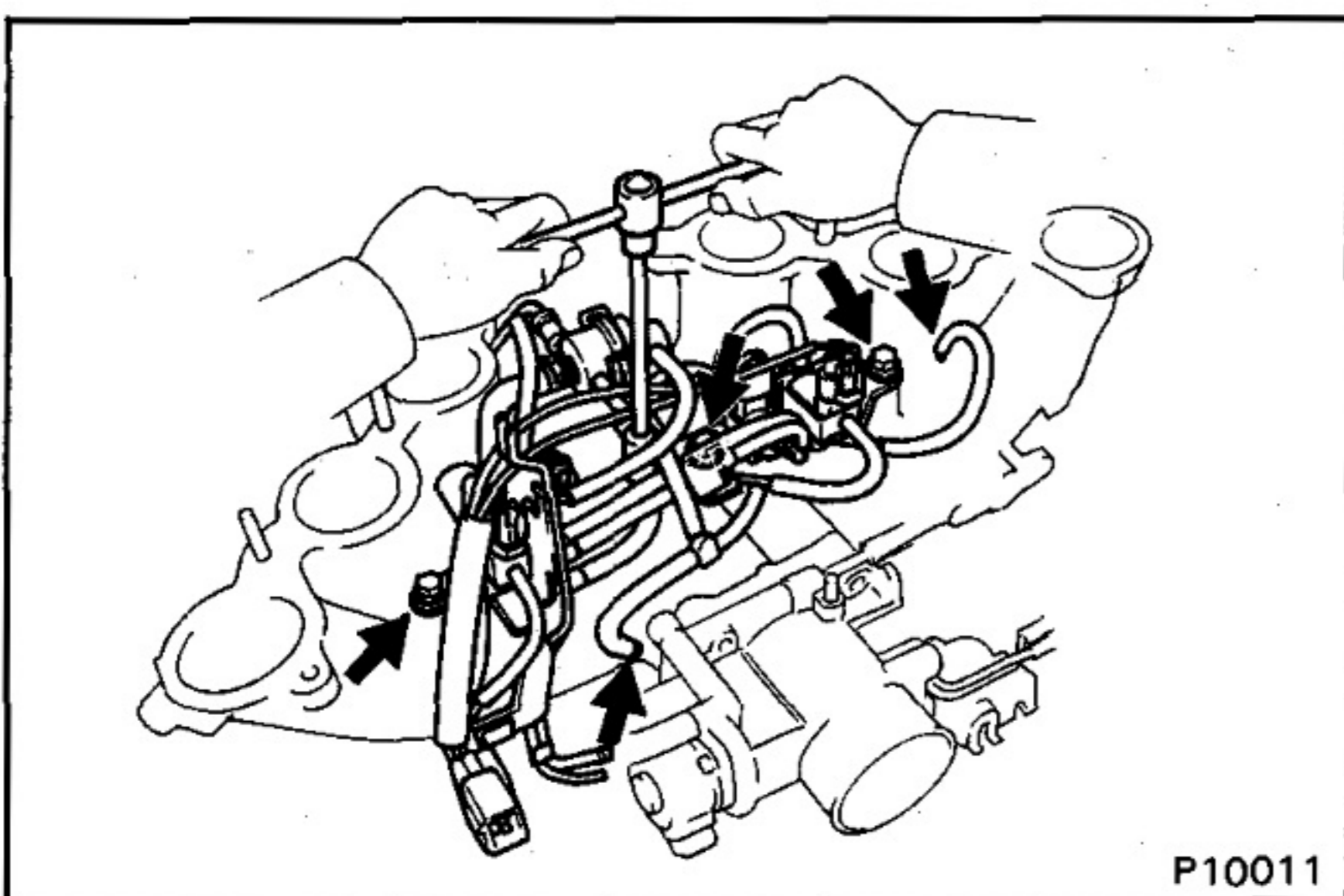

- (c) Install the emission control valve set assembly with the four bolts.

Torque: 20 N·m (200 kgf·cm, 14 ft·lbf)

- (d) Connect the air hose and vacuum hose to the air intake chamber.

5. REINSTALL AIR INTAKE CHAMBER

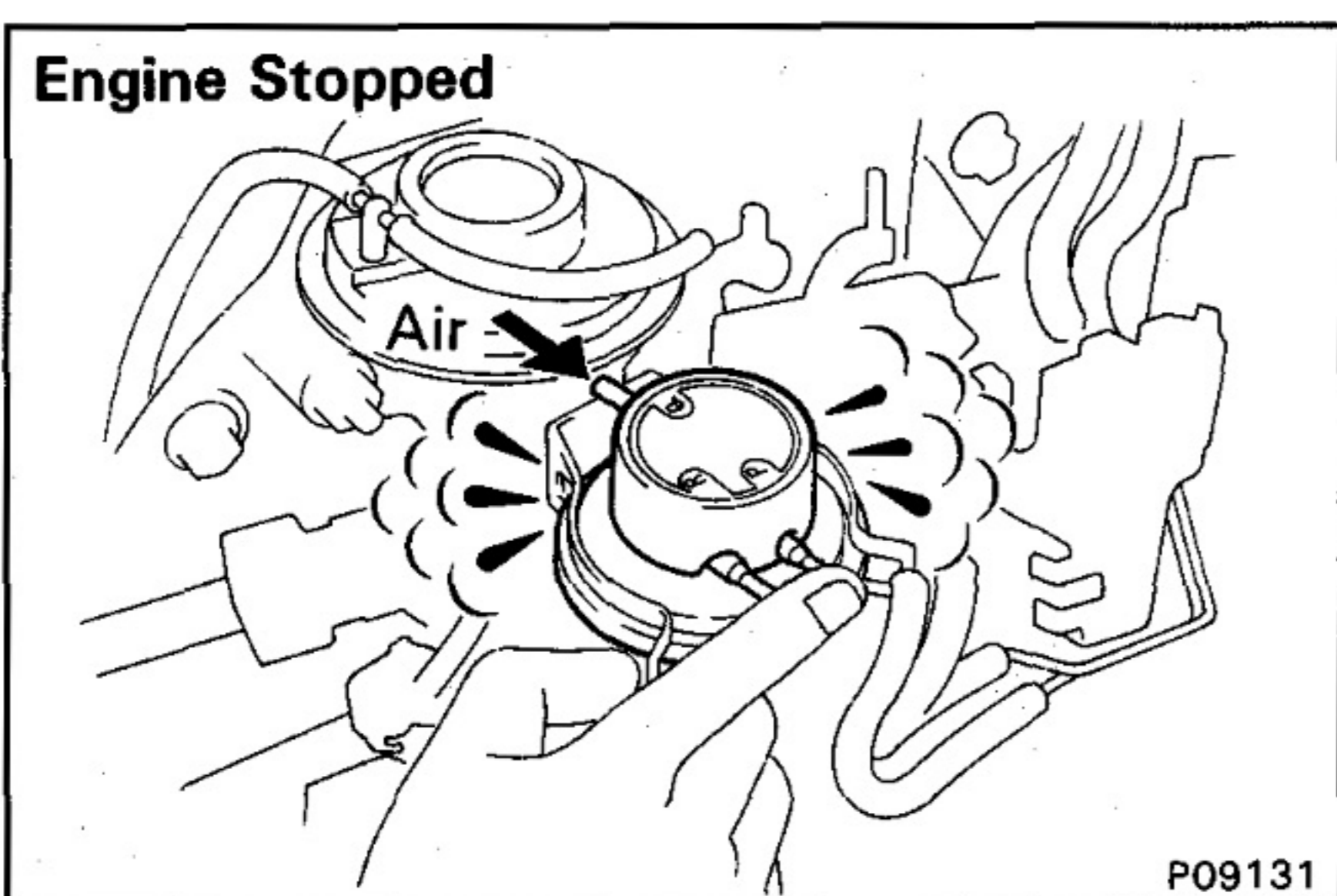

INSPECTION OF EGR VACUUM MODULATOR

INSPECT EGR VACUUM MODULATOR OPERATION

- (a) Disconnect the vacuum hoses from ports P, Q and R of the EGR vacuum modulator.
- (b) Block ports P and R with your finger.
- (c) Blow air into port Q, and check that the air passes through to the air filter side freely.

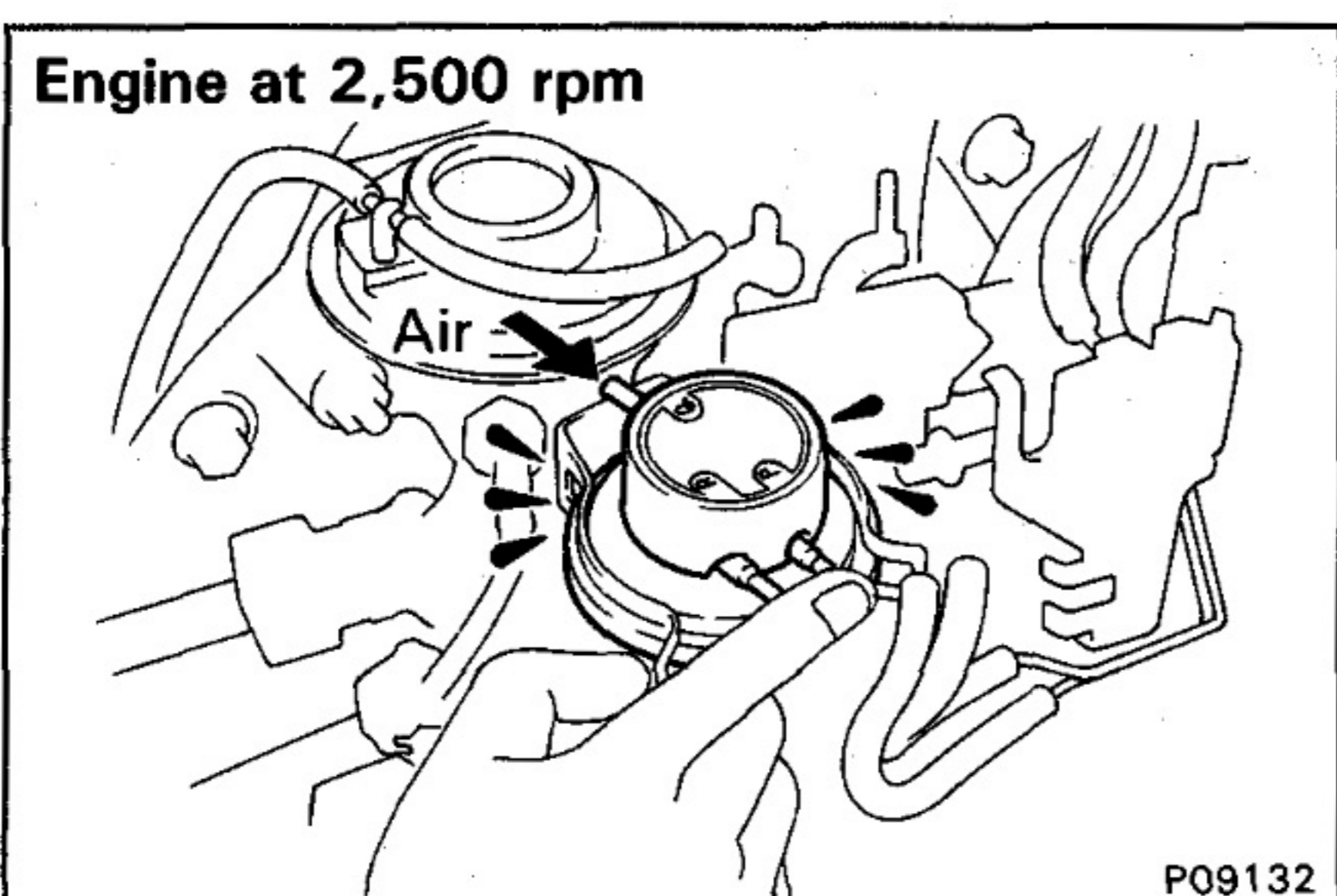

- (d) Start the engine, and maintain speed at 2,500 rpm.
- (e) Repeat the above test. Check that there is a strong resistance to air flow.

If operation is not as specified, replace the EGR vacuum modulator.

- (f) Reconnect the vacuum hoses to the proper locations.

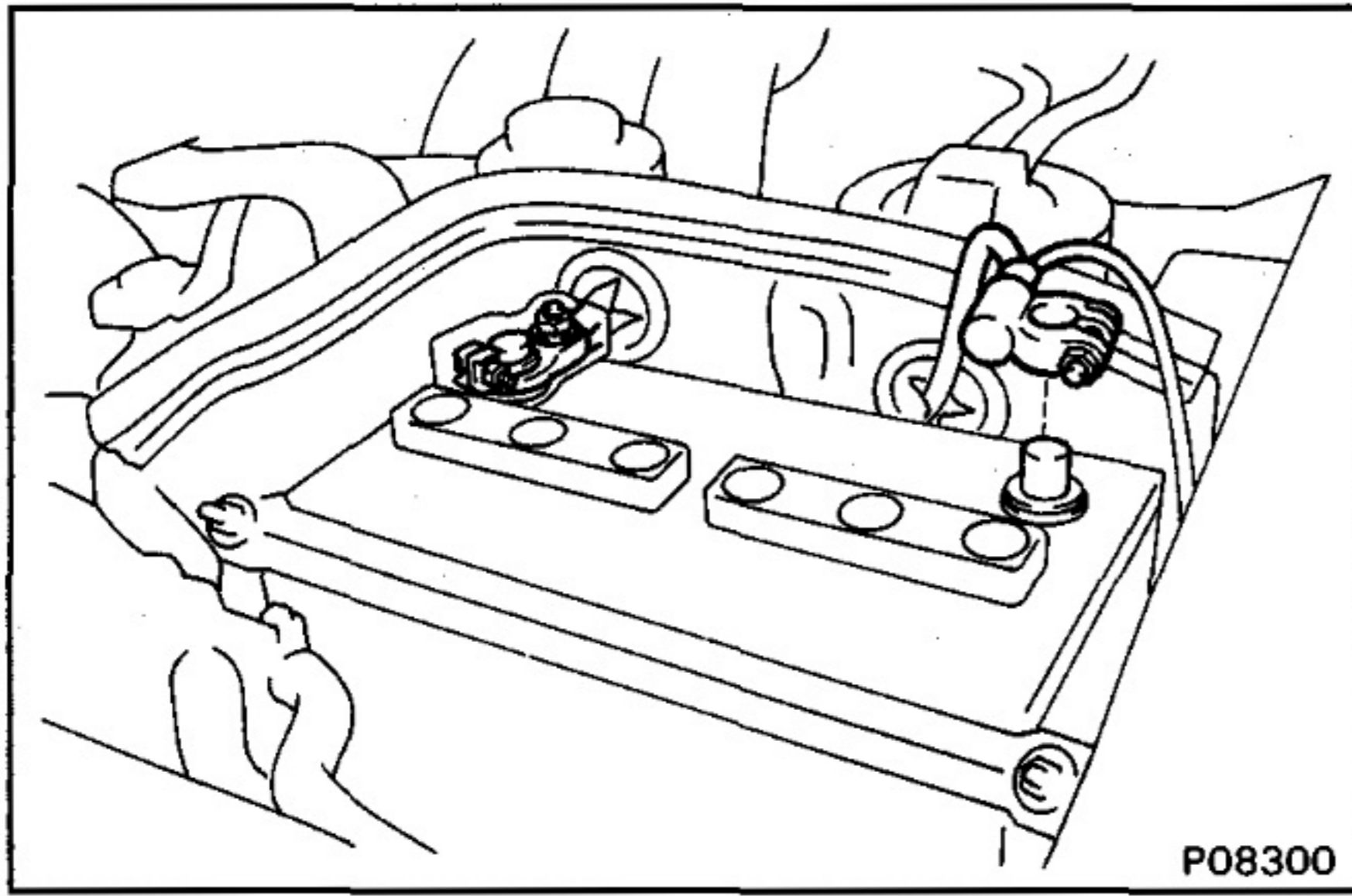

INSPECTION OF EGR VALVE

1. DISCONNECT CABLE FROM NEGATIVE TERMINAL OF BATTERY

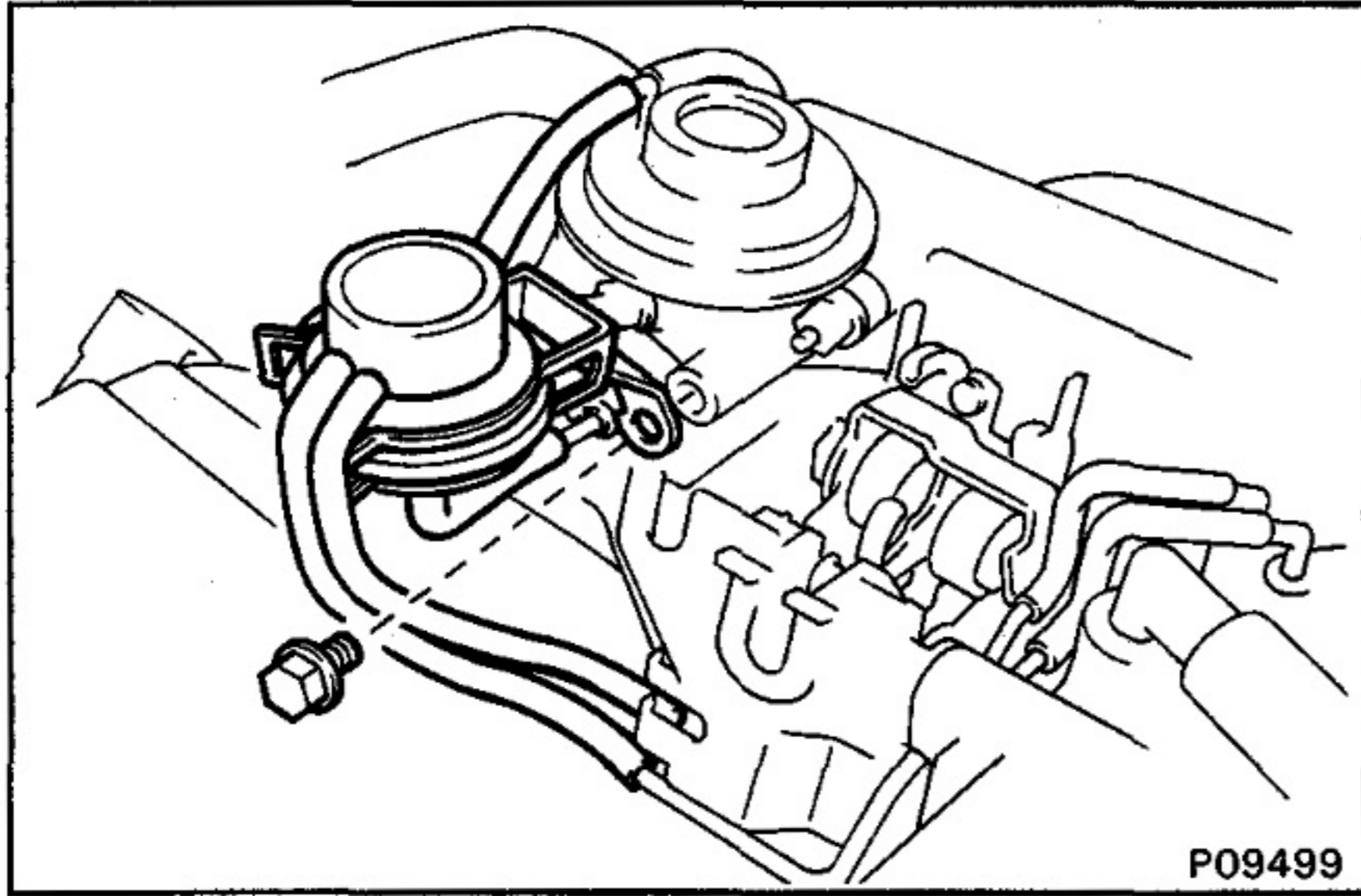

2. REMOVE EGR VACUUM MODULATOR

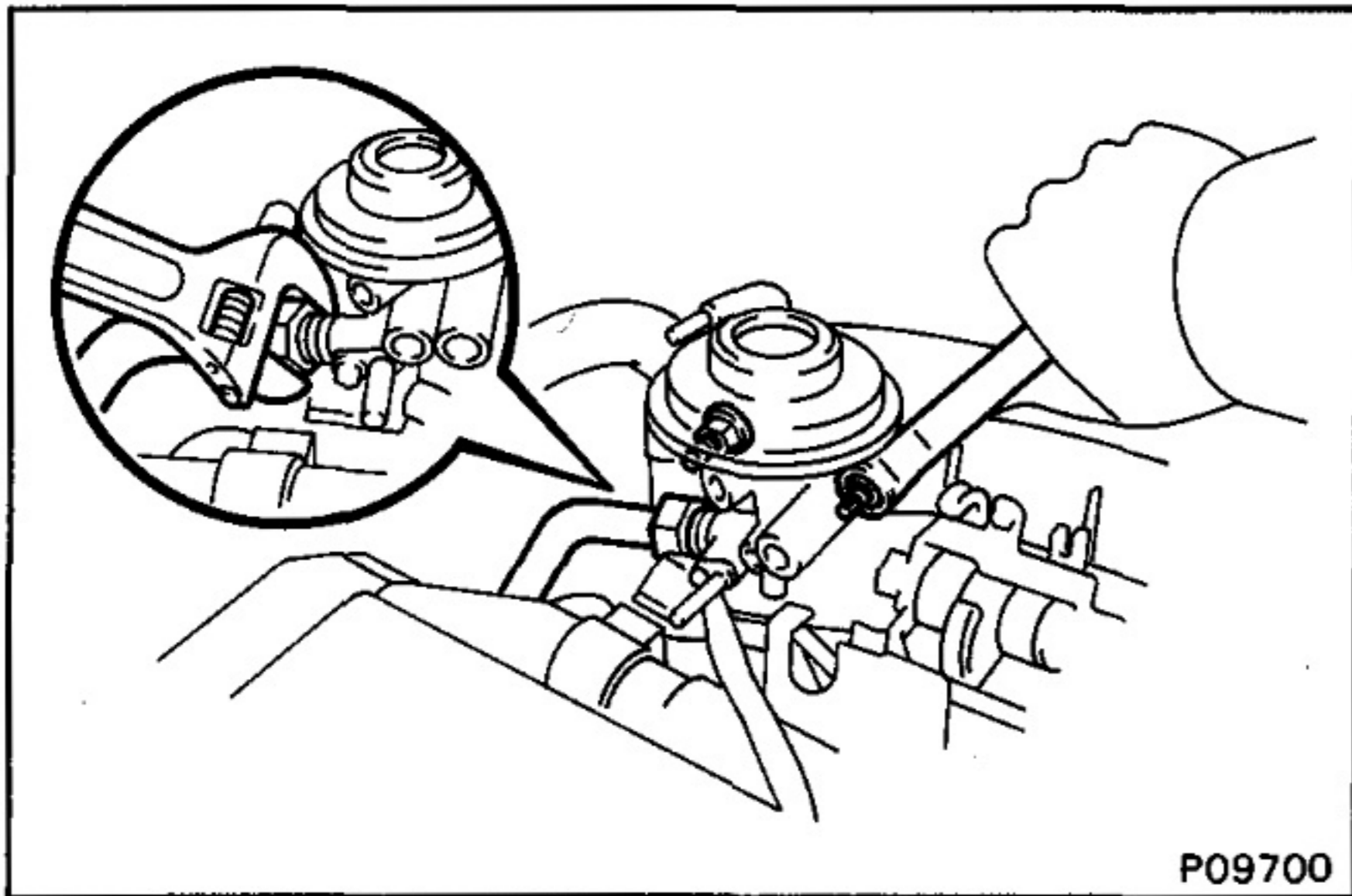

3. REMOVE EGR VALVE

- (a) Loosen the EGR pipe union nut.
- (b) Remove the two nuts holding the EGR valve and air intake chamber.
- (c) Disconnect the vacuum hose from the EGR valve.

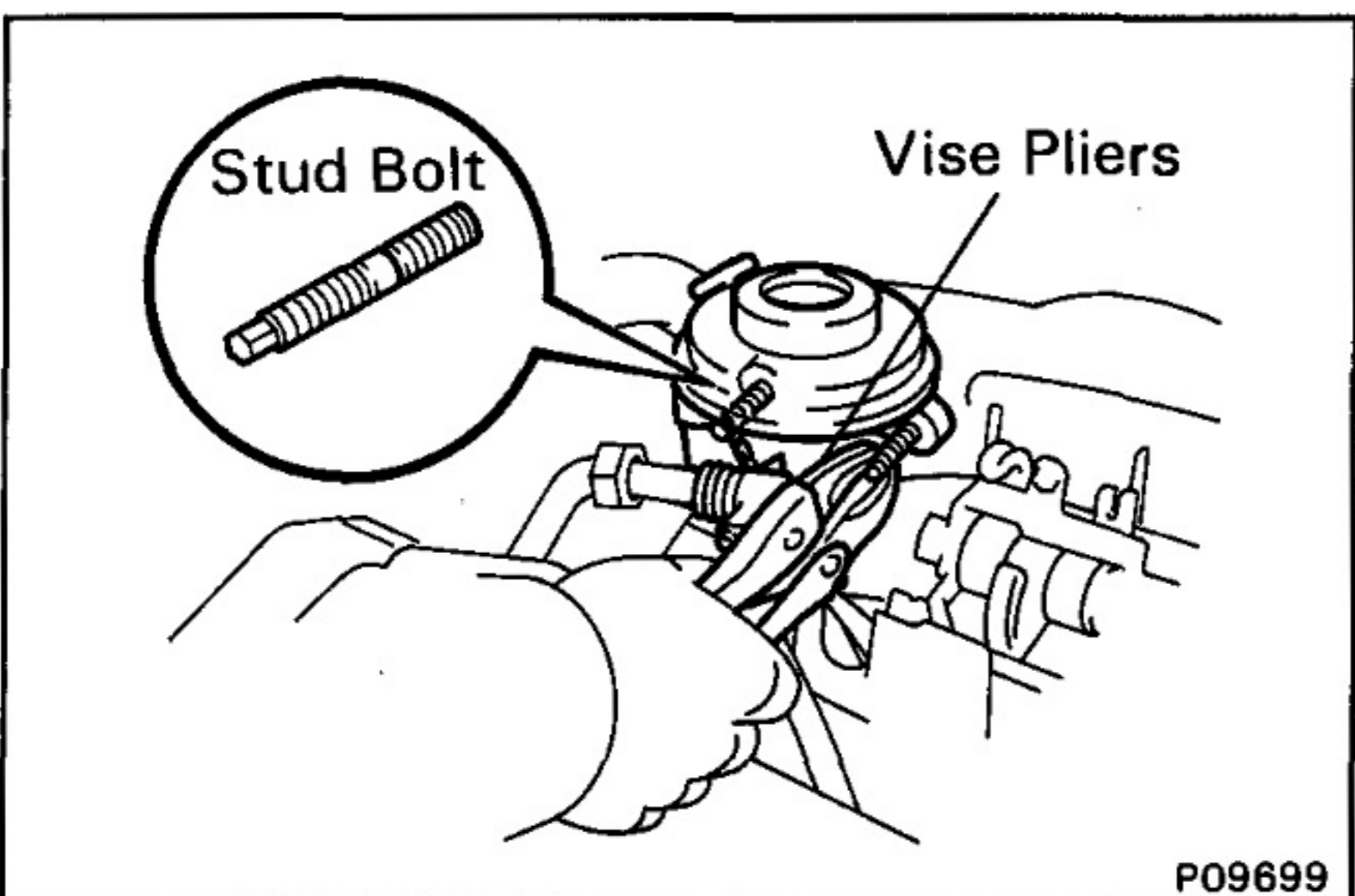

- (d) Using vise pliers, remove the two stud bolts, EGR valve and gasket.

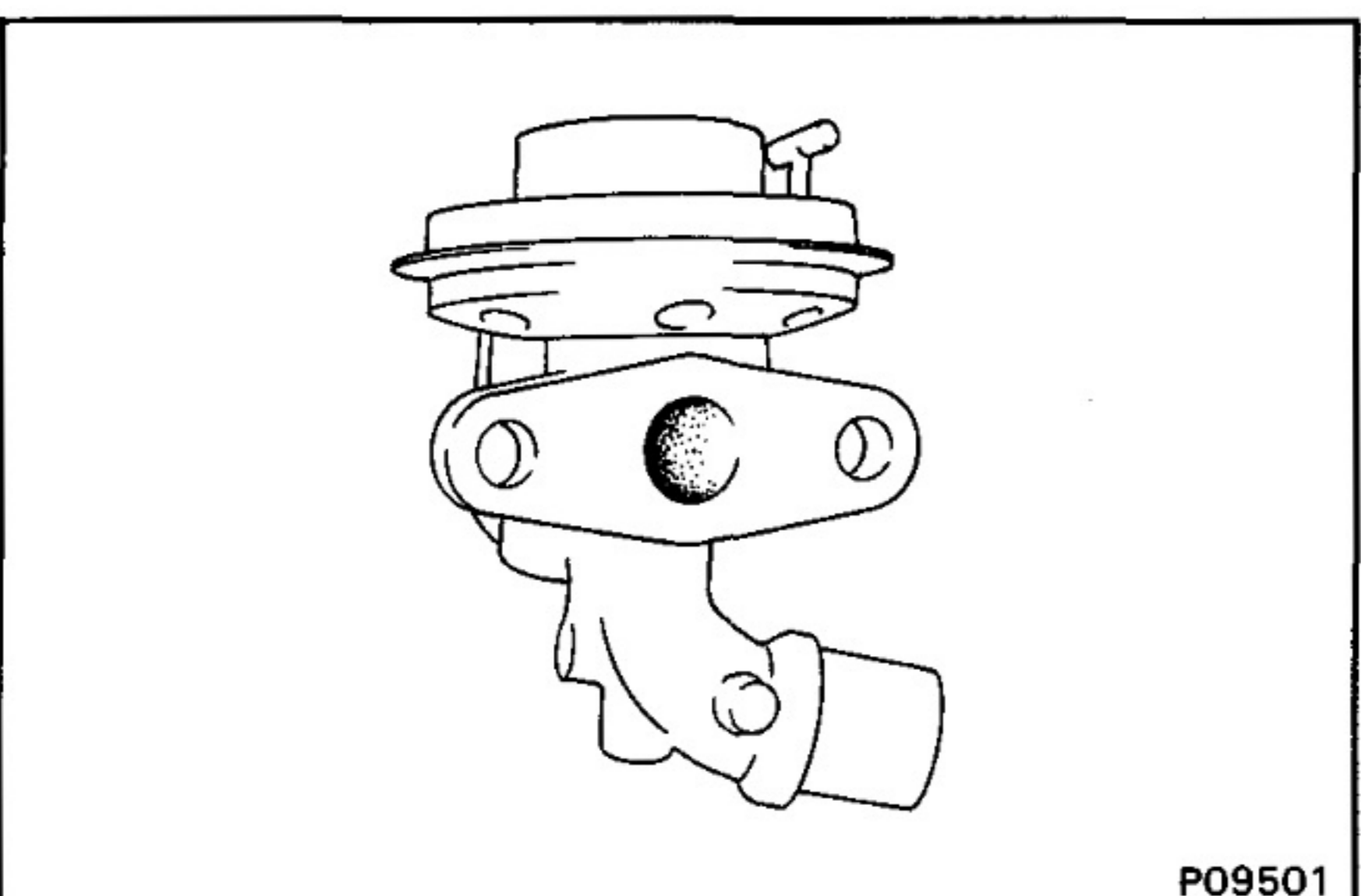

4. INSPECT EGR VALVE

Check for sticking and heavy carbon deposits.
If a problem is found, replace the valve.

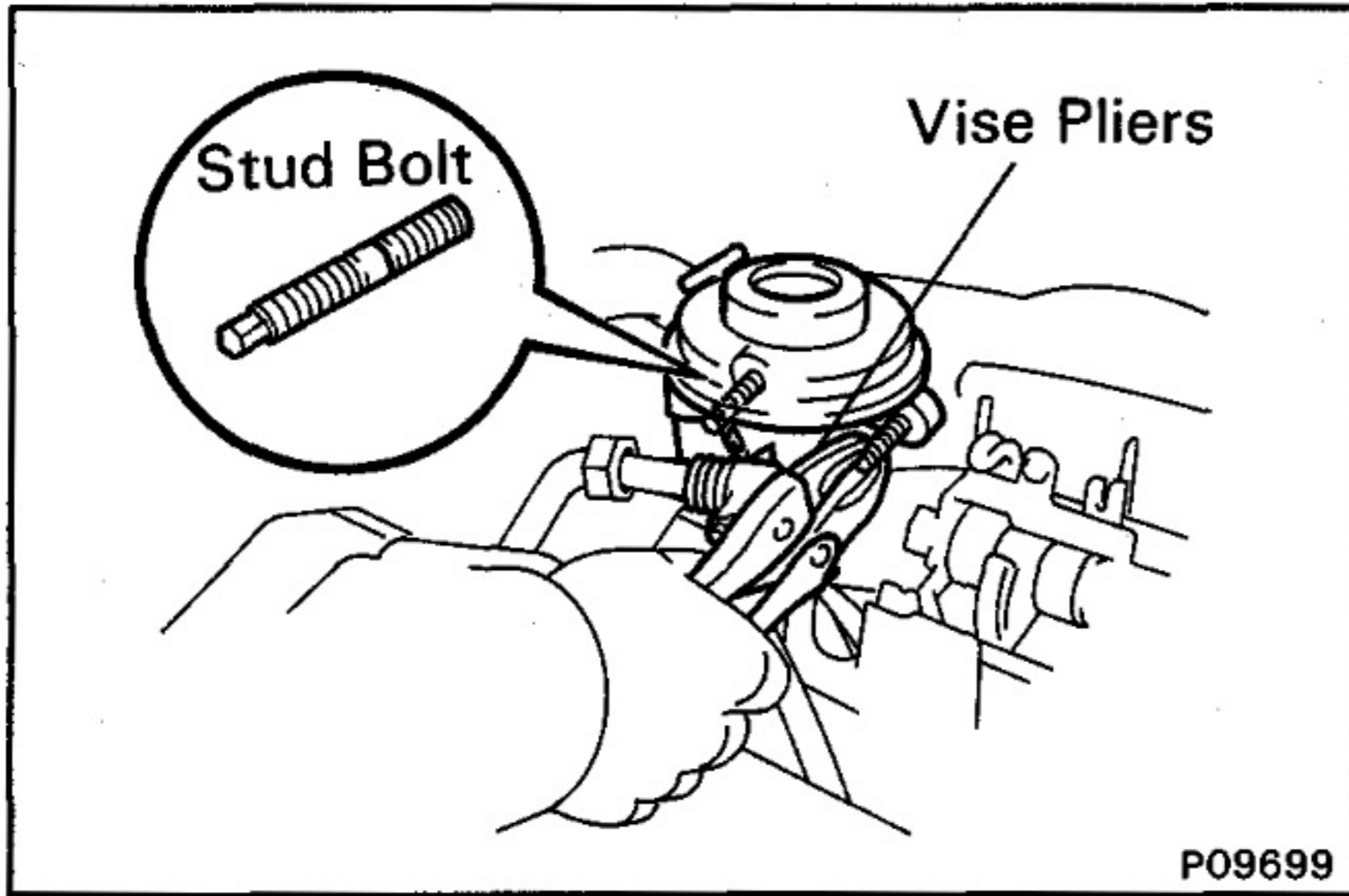
**5. REINSTALL EGR VALVE**

- (a) Using vise pliers, temporarily install a new gasket, and EGR valve with the two stud bolts.

Torque: 10 N·m (105 kgf·cm, 8 ft·lbf)

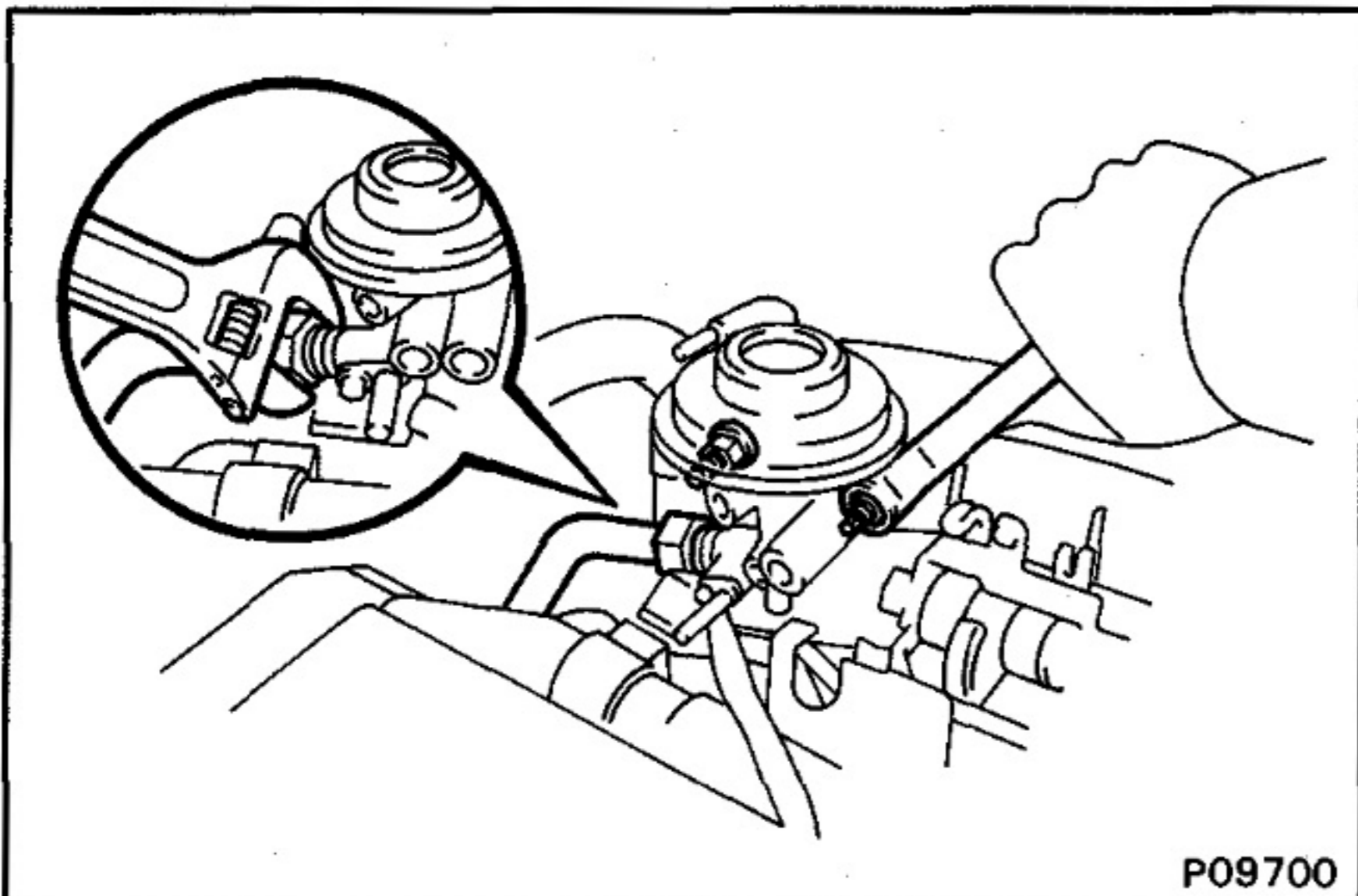

- (b) Connect the vacuum hose to the EGR valve.

- (c) Install the two nuts holding the EGR valve and air intake chamber.

Torque: 19 N·m (195 kgf·cm, 14 ft·lbf)

- (d) Tighten the union nut of the EGR pipe.

Torque: 64 N·m (650 kgf·cm, 47 ft·lbf)

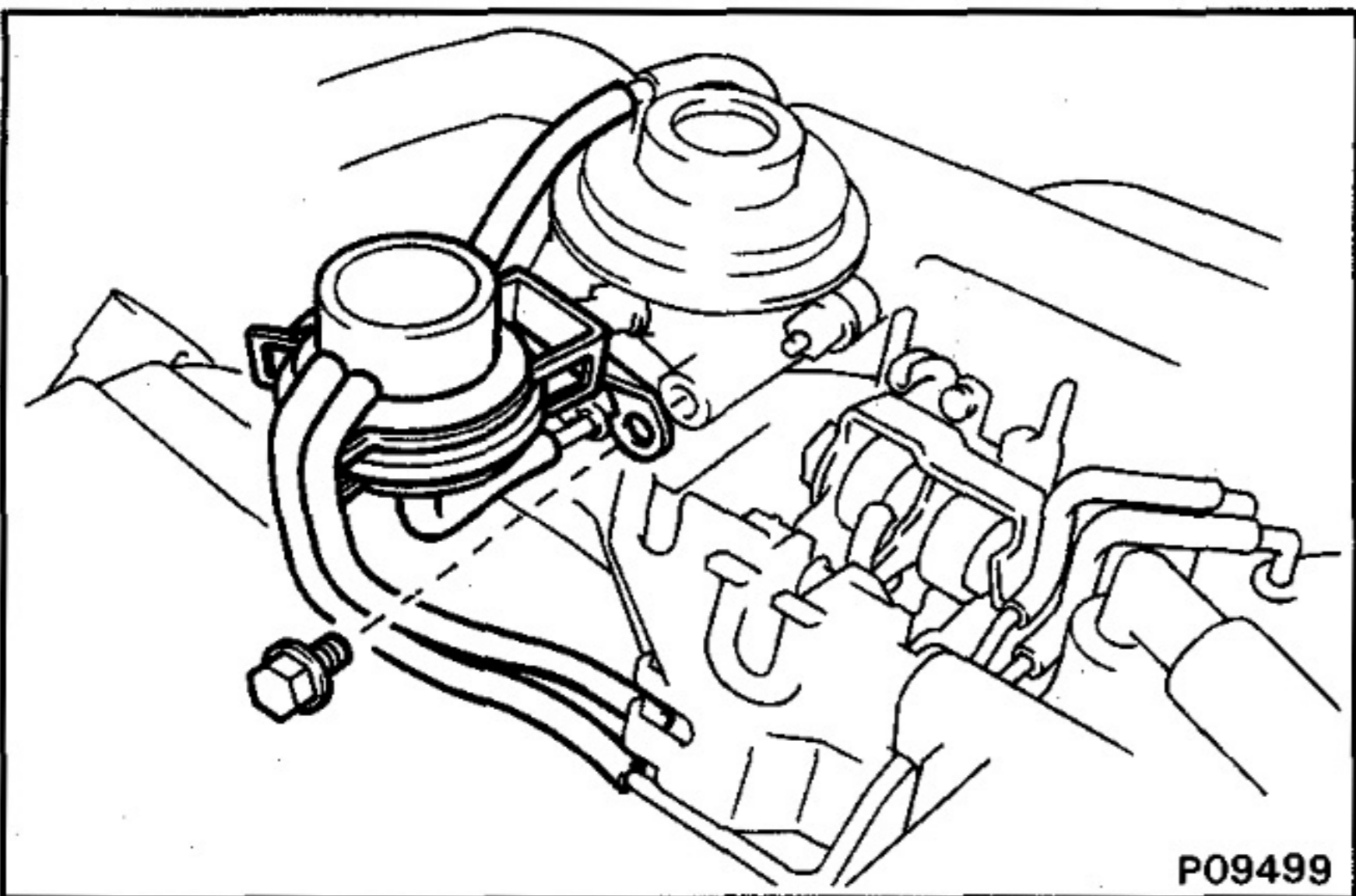
**6. REINSTALL EGR VACUUM MODULATOR**

Torque: 18 N·m (185 kgf·cm, 13 ft·lbf)

7. RECONNECT CABLE TO NEGATIVE TERMINAL OF BATTERY

AIR SUCTION (AS) SYSTEM

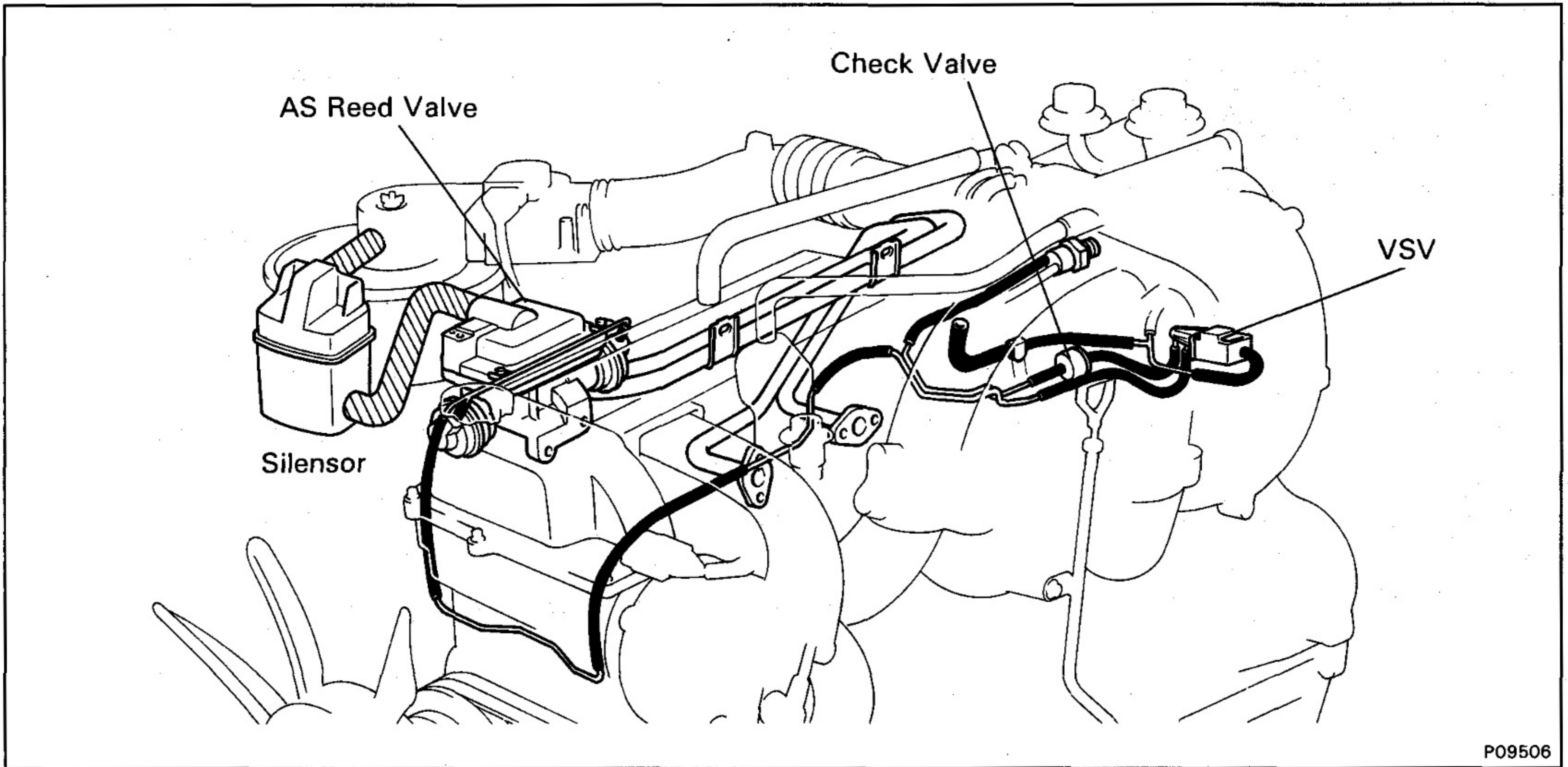

P09506

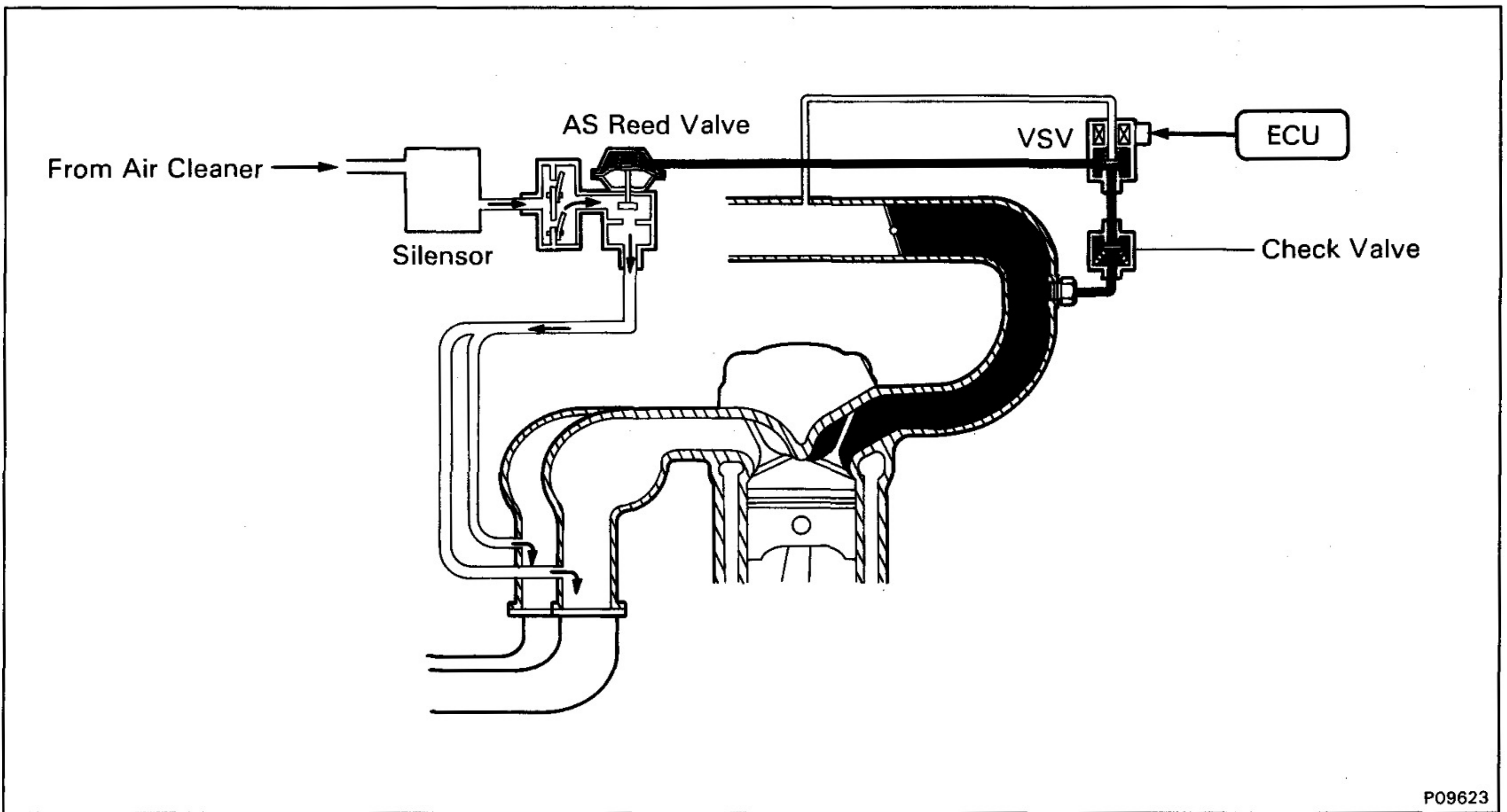

P09623

To reduce HC and CO emissions, this system draws in air into exhaust ports to accelerate oxidation, using vacuum generated by the exhaust pulsation in the exhaust manifold.

Condition	Coolant Temp.	Throttle position	Vehicle speed	RPM	VSV	AS
Normal driving	Below 35°C (95°F)	—	—	Below 3,150 rpm	ON	ON
				Above 3,150 rpm	OFF	OFF
Deceleration	Above 35°C (95°F)	Idling	Below 15 km/h (9 mph)	Below 1,200 (1,500)* rpm	OFF	OFF
				Above 1,400 (1,700)* rpm	ON	ON
			Above 15 km/h (9 mph)	—	ON	ON

Remarks: () is A/C ON.

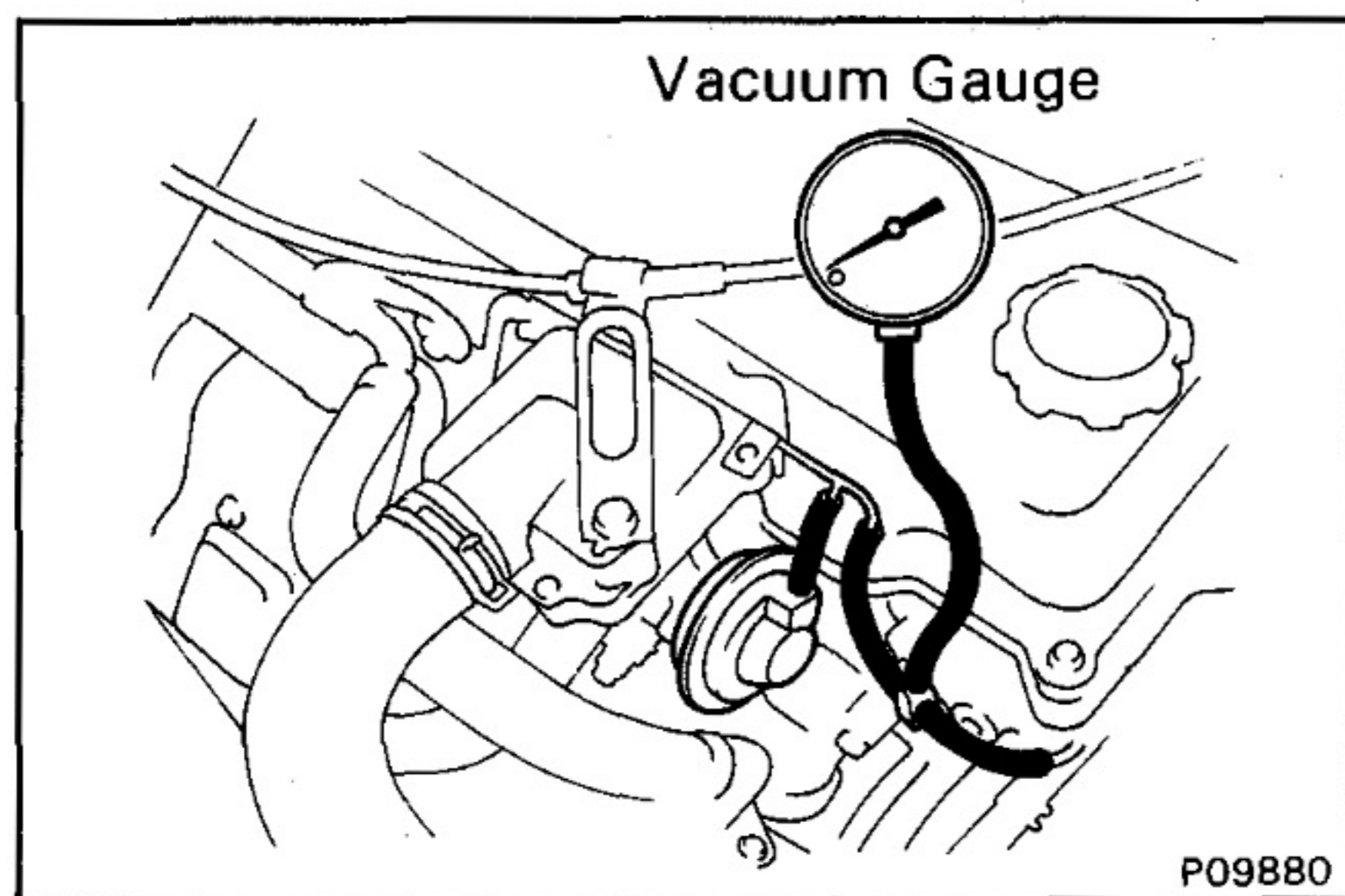

INSPECTION OF AS SYSTEM

1. VISUALLY INSPECT HOSES AND PIPES FOR CRACKS, KINKS, DAMAGE OR LOOSE CONNECTIONS

2. INSTALL VACUUM GAUGE

Using a 3-way connector, connect a vacuum gauge to the hose between the reed valve and No.2 water by-pass pipe.

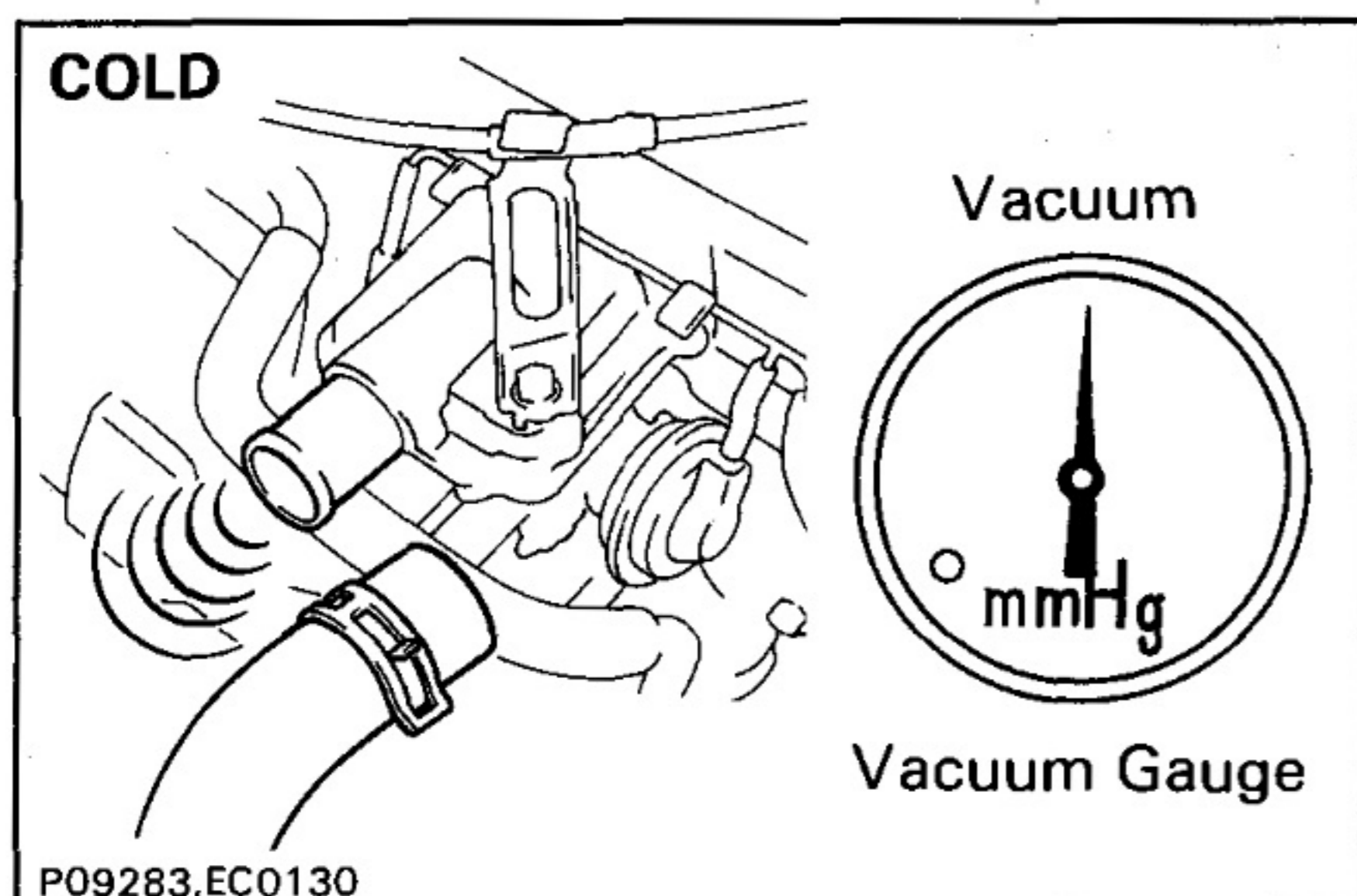

3. INSPECT AS SYSTEM OPERATION WITH COLD ENGINE

- (a) The engine coolant temperature should be below 35°C (95°F).
- (b) Disconnect the No.2 air hose from the AS reed valve.
- (c) Start the engine.
- (d) Check that the vacuum gauge indicates vacuum at idle.
- (e) Check that a bubbling noise is heard from the AS reed valve.

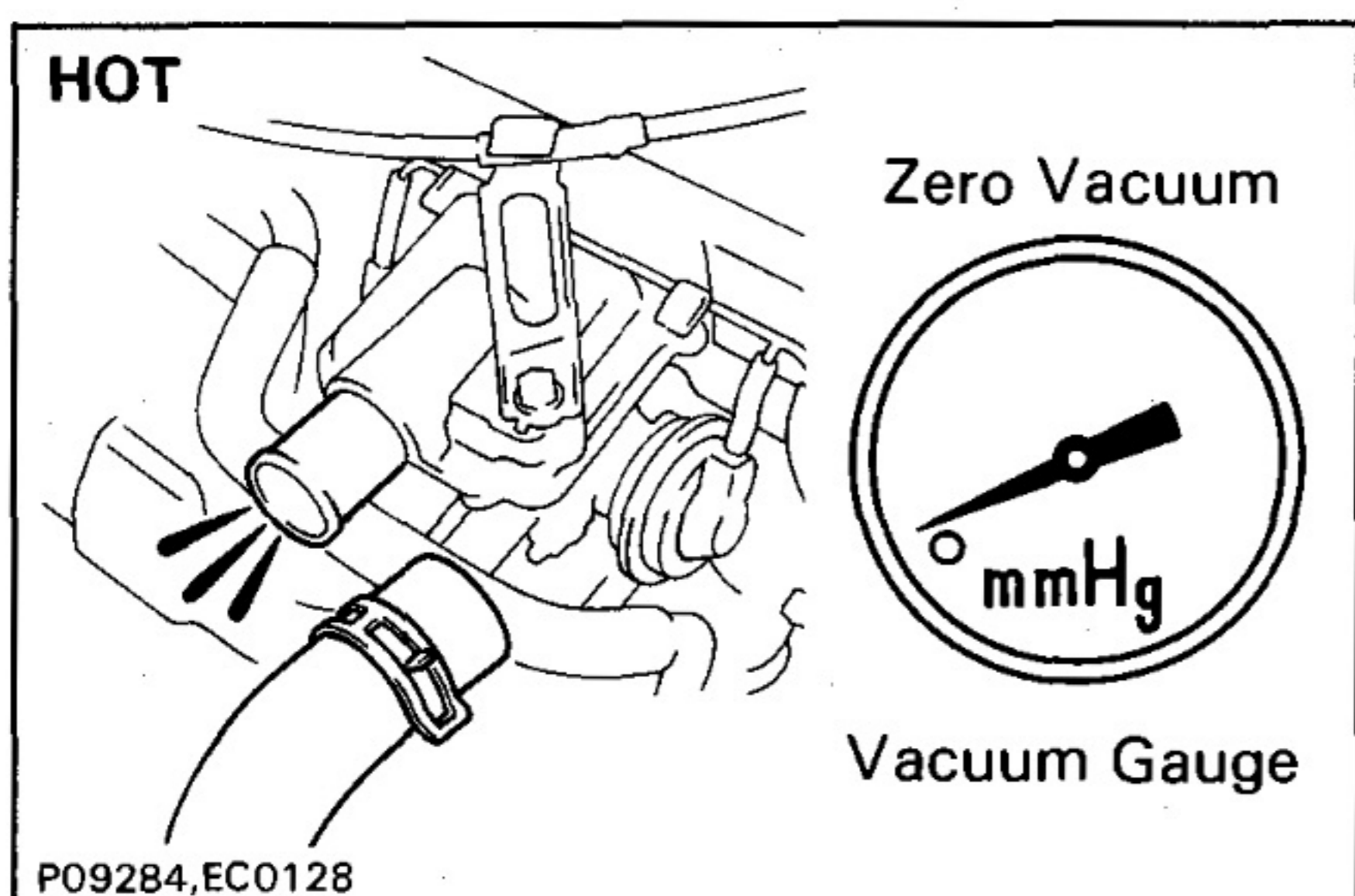

4. INSPECT AS SYSTEM OPERATION WITH HOT ENGINE

- (a) Warm up the engine.
- (b) Check that the vacuum gauge indicates zero vacuum at idle.
- (c) With the engine idling, check that a bubbling noise is not heard from the AS reed valve.

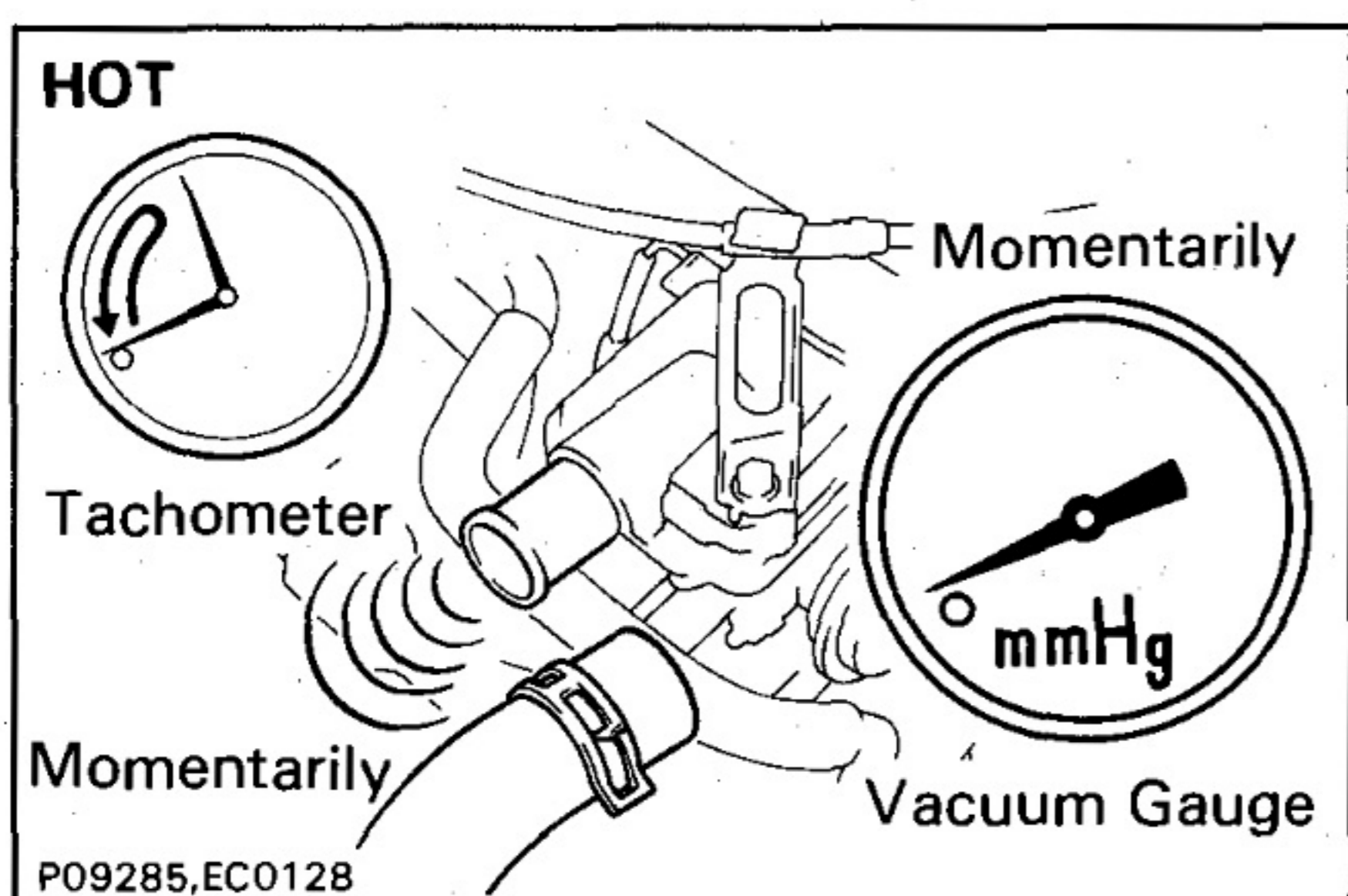

- (d) Race the engine about 2,500 rpm and quickly close the throttle valve.
- (e) Check that the vacuum gauge indicates zero vacuum momentarily.
- (f) Check that a bubbling noise stops momentarily.

- (g) Reconnect the No.2 air hose to the AS reed valve.

5. REMOVE VACUUM GAUGE

Remove the vacuum gauge, and reconnect the vacuum hose to the proper location.

If you detect a problem when doing the above inspection, inspect each part.

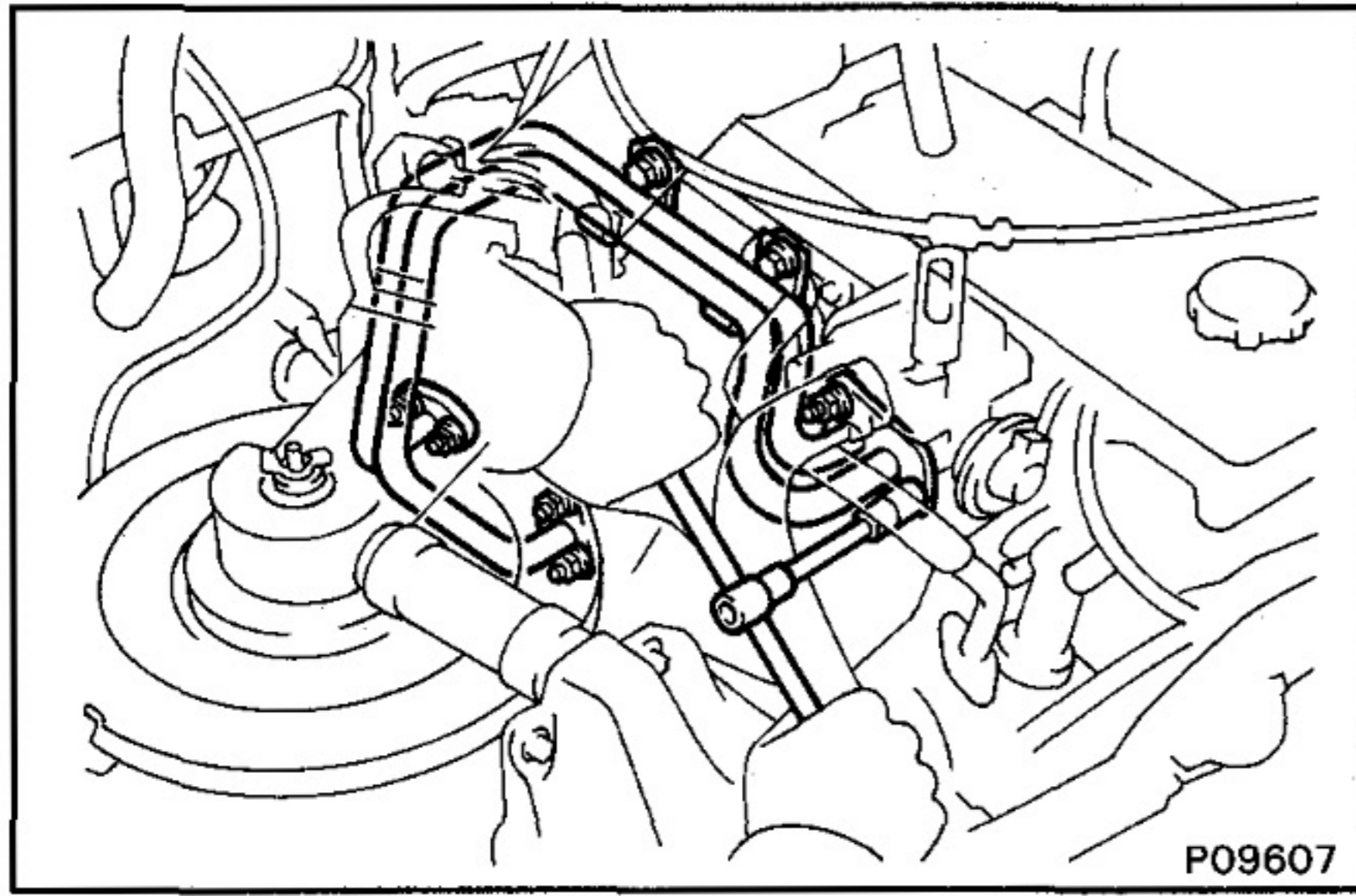

INSPECTION OF AS REED VALVE

1. REMOVE AIR PIPE

Remove the two bolts, six nuts, air pipe and three gaskets.

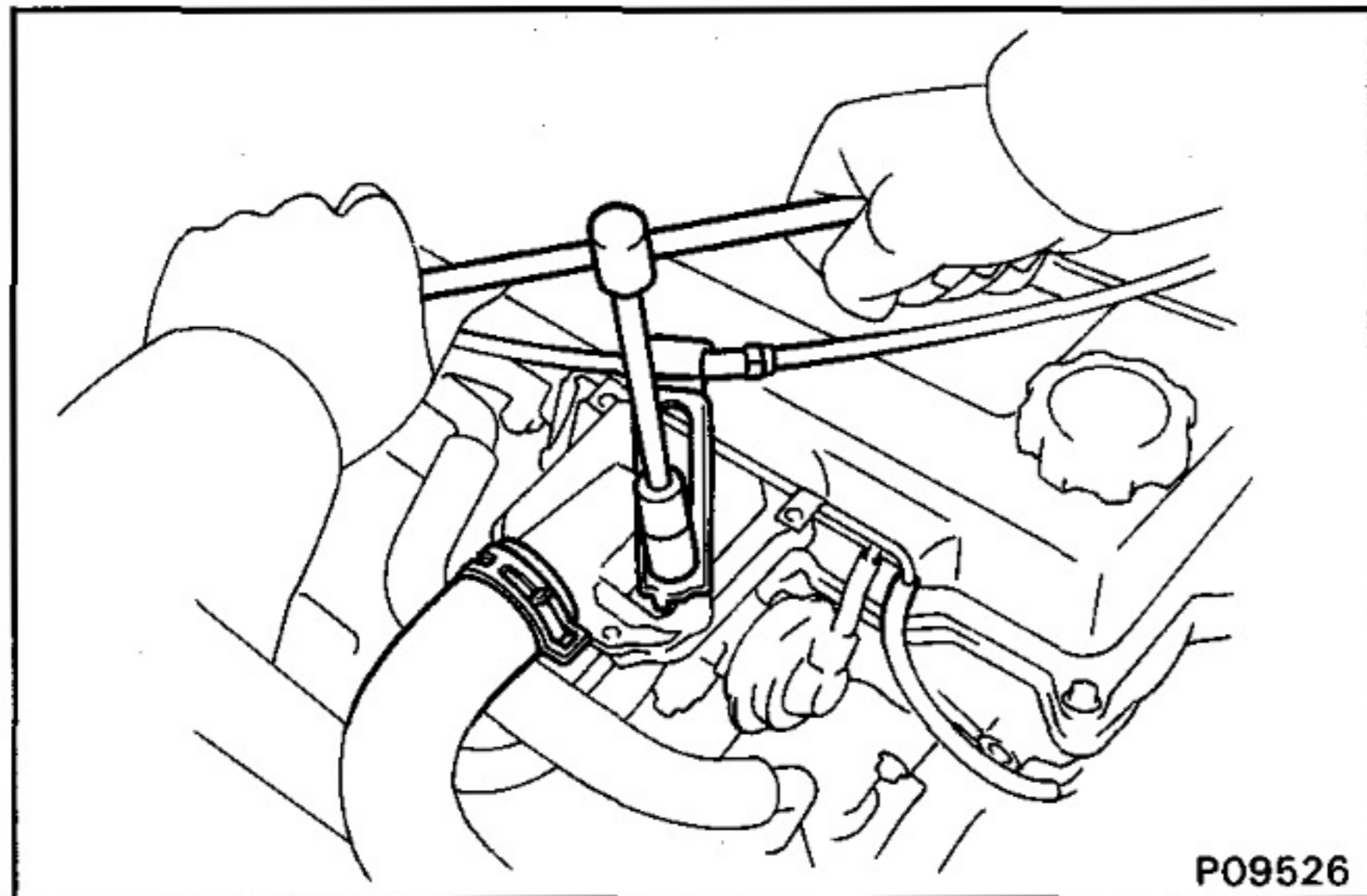

2. REMOVE AS REED VALVE

(a) Remove the bolt and disconnect accelerator cable clamp.

(b) Disconnect the vacuum hose and No.2 air hose.

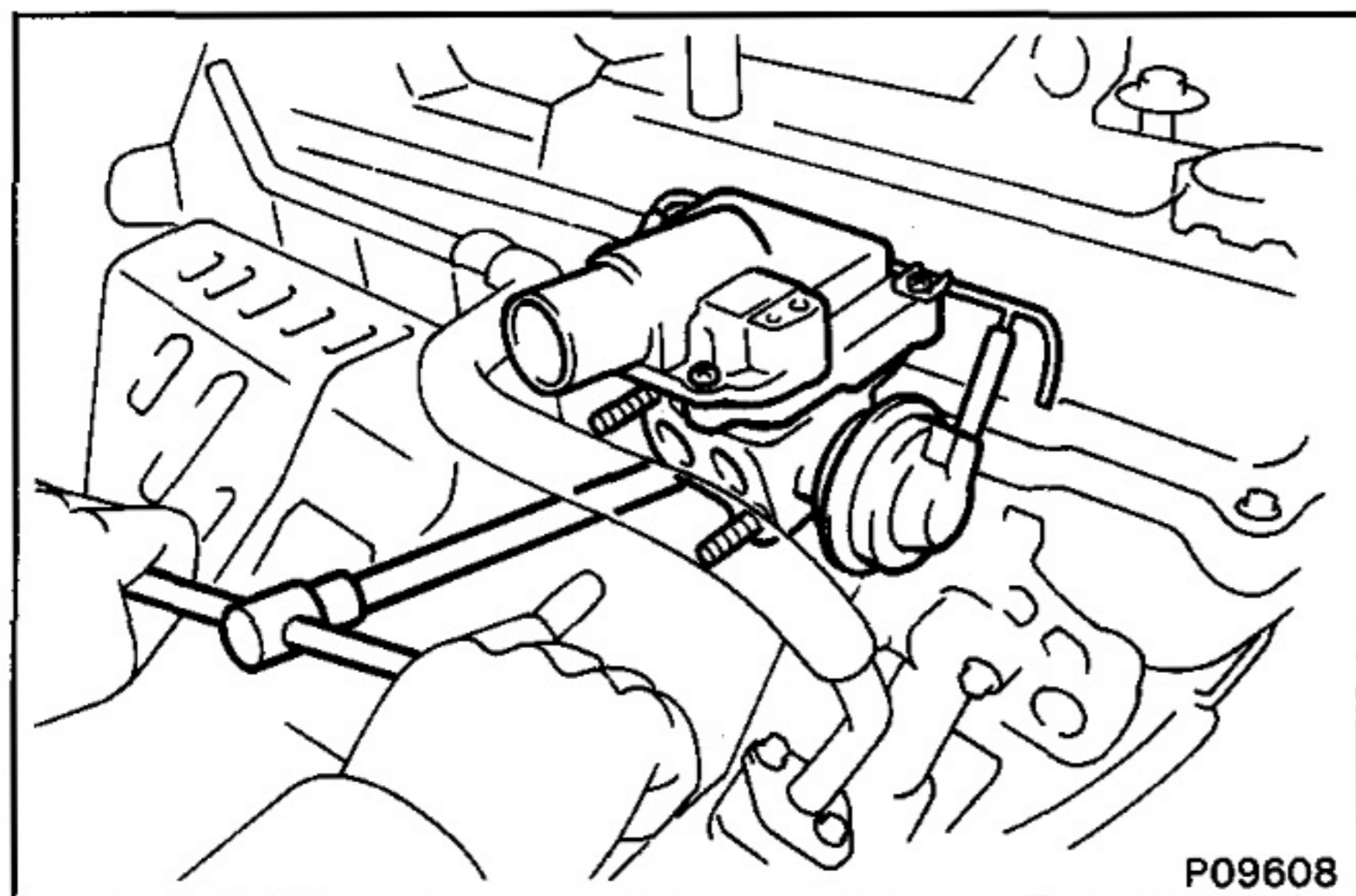

(c) Remove the two bolts and AS reed valve.

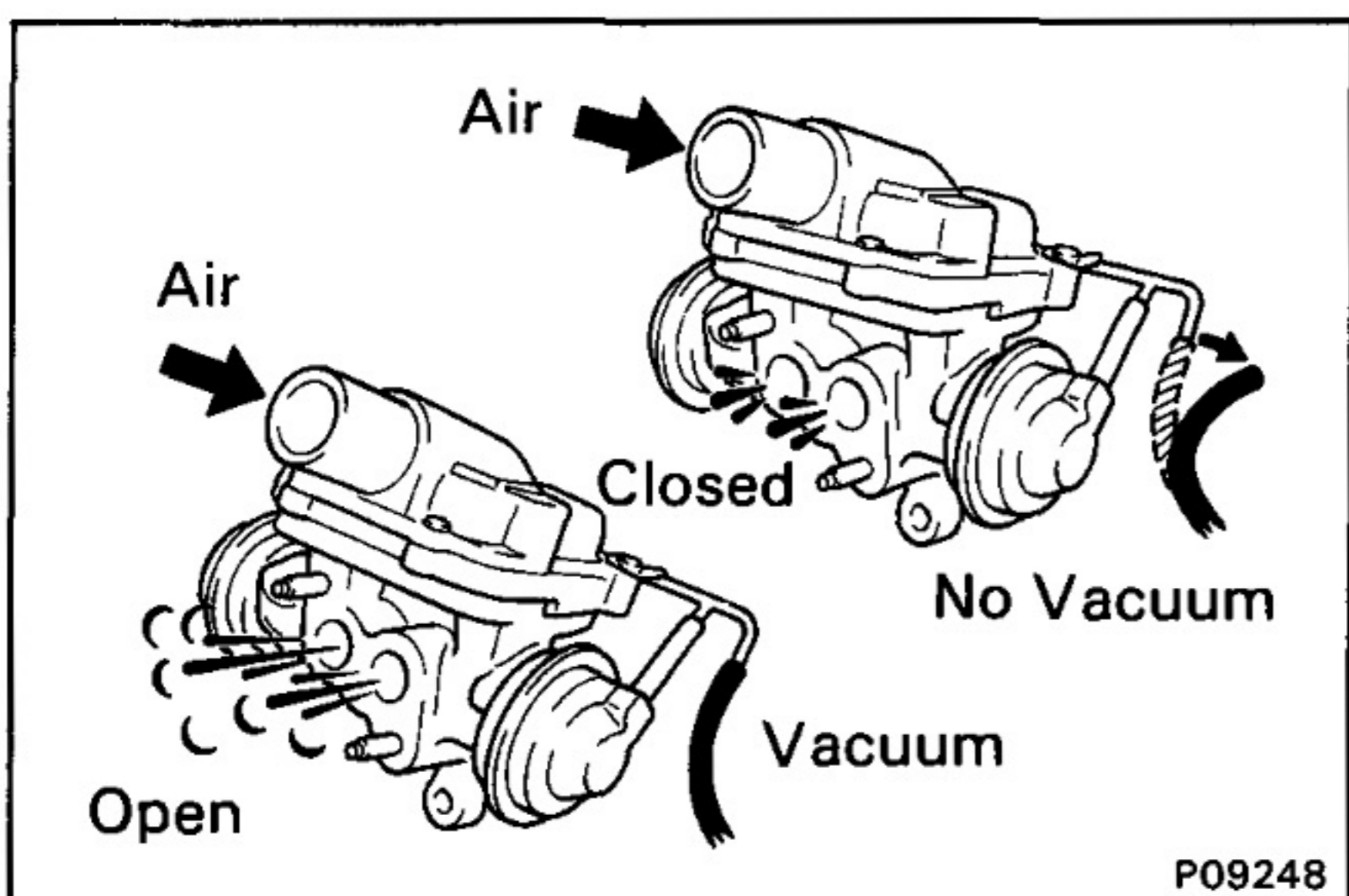

3. INSPECT AS REED VALVE

(a) Apply vacuum to the reed valve diaphragm.

(b) Blow air into a pipe and check that the reed valve is open.

(c) Release the vacuum and check that the reed valve is closed.

If operation is not as specified, replace the reed valve.

4. REINSTALL AS REED VALVE

(a) Install the AS reed valve with the two bolts.

Torque: 20 N·m (200 kgf·cm, 14 ft·lbf)

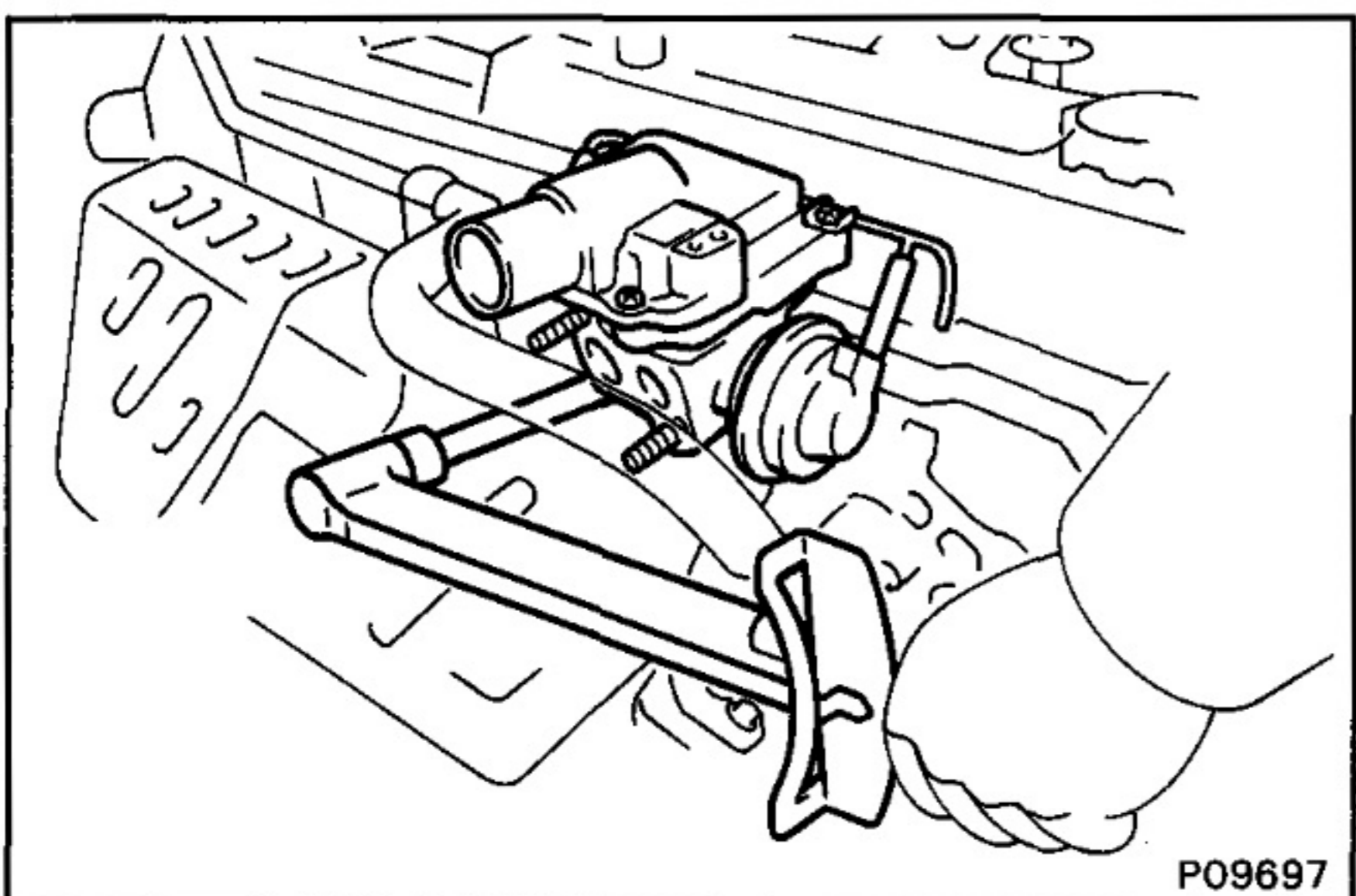

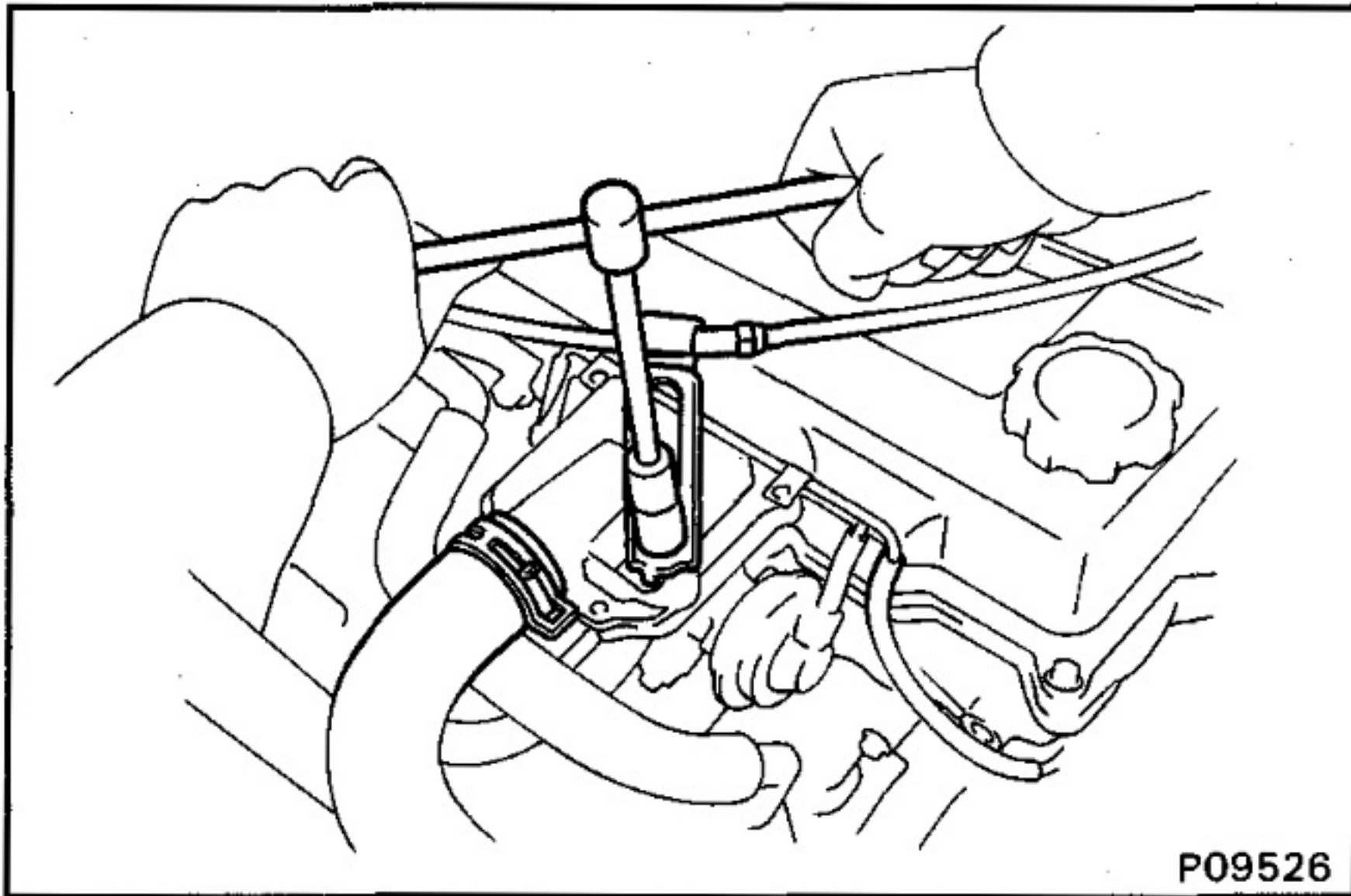

- (b) Connect the No.2 air hose and vacuum hose.
- (c) Connect the accelerator cable clamp with the bolt.

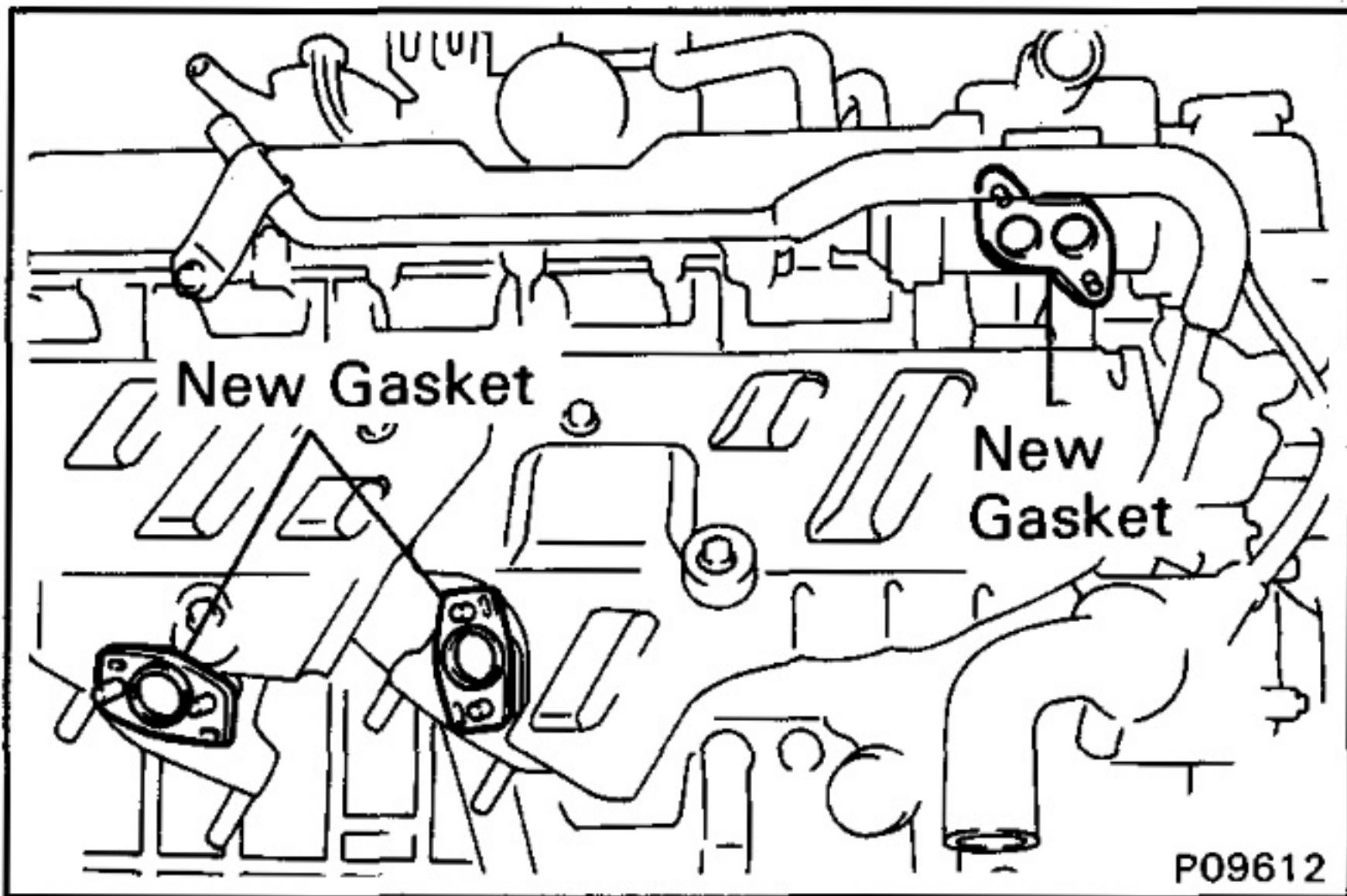

5. REINSTALL AIR PIPE

- (a) Install three new gaskets on the exhaust manifolds and AS reed valve.

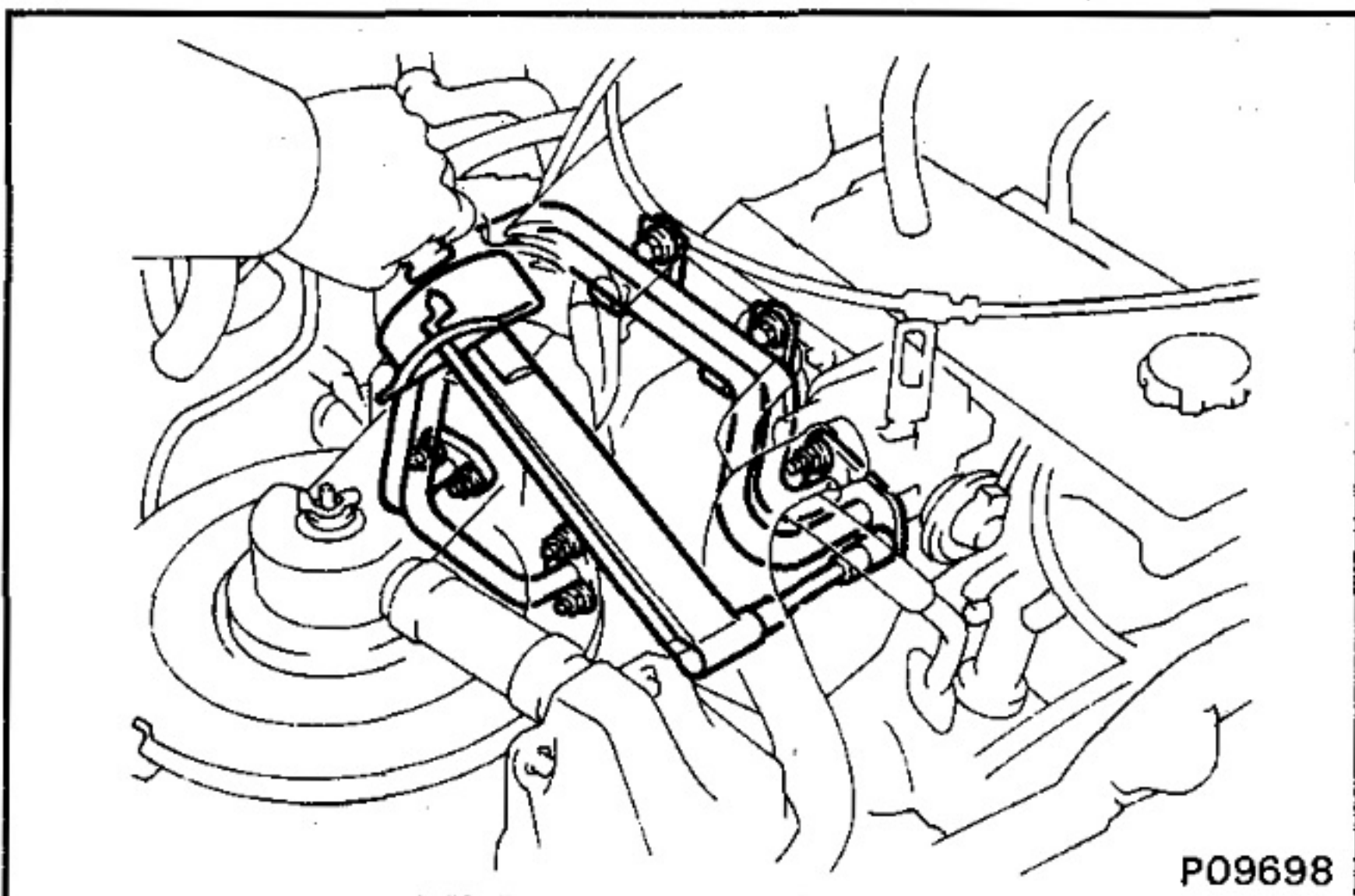

- (b) Install the air pipe with the two bolts and six nuts.
Torque: 20 N·m (200 kgf·cm, 14 ft·lbf) for Bolt
Torque: 21 N·m (210 kgf·cm, 15 ft·lbf) for Nut

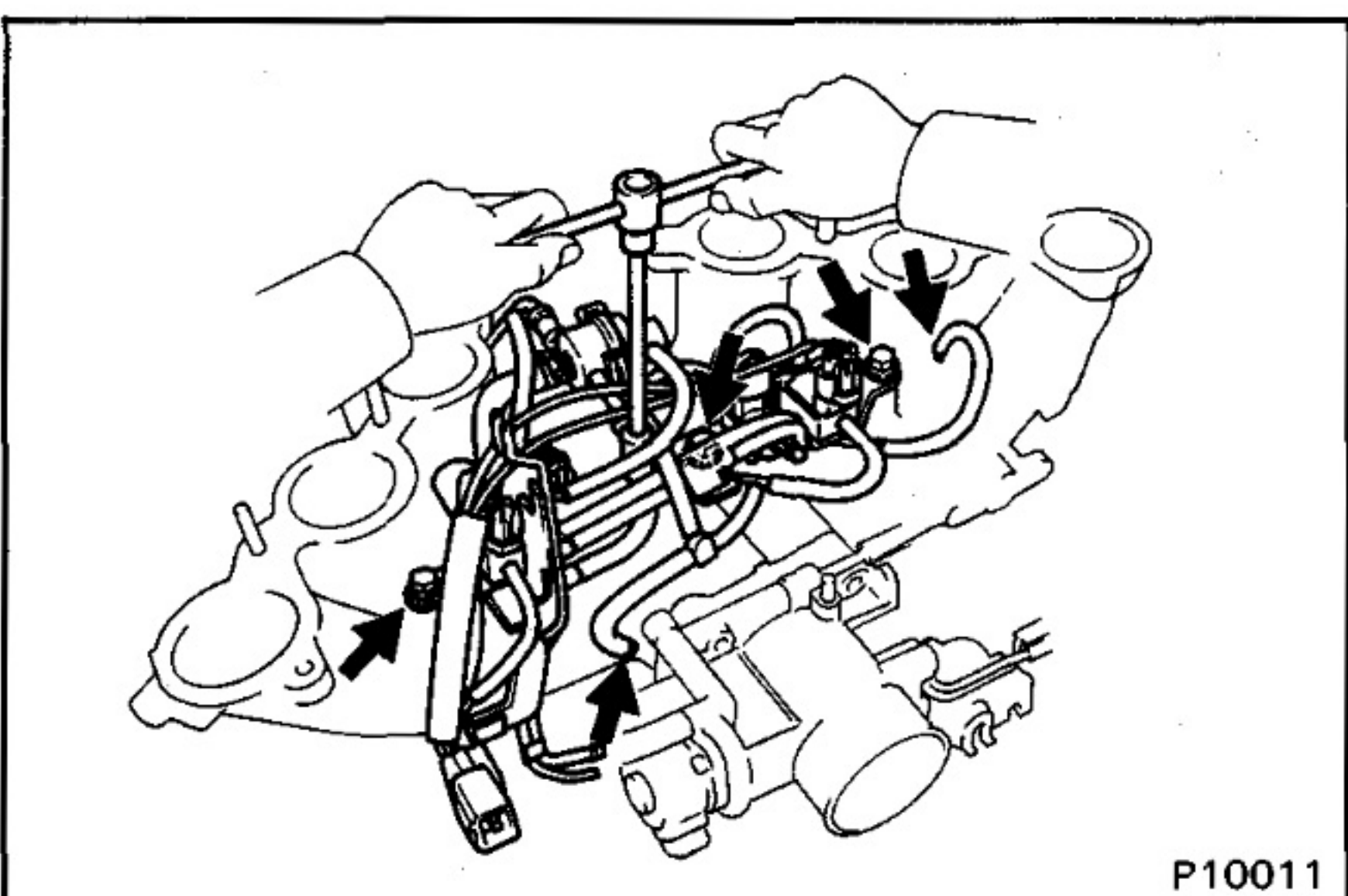

INSPECTION OF VSV

1. REMOVE AIR INTAKE CHAMBER

2. REMOVE VSV

- (a) Disconnect the air hose and vacuum hose from the air intake chamber.
- (b) Remove the four bolts and emission control valve set assembly.

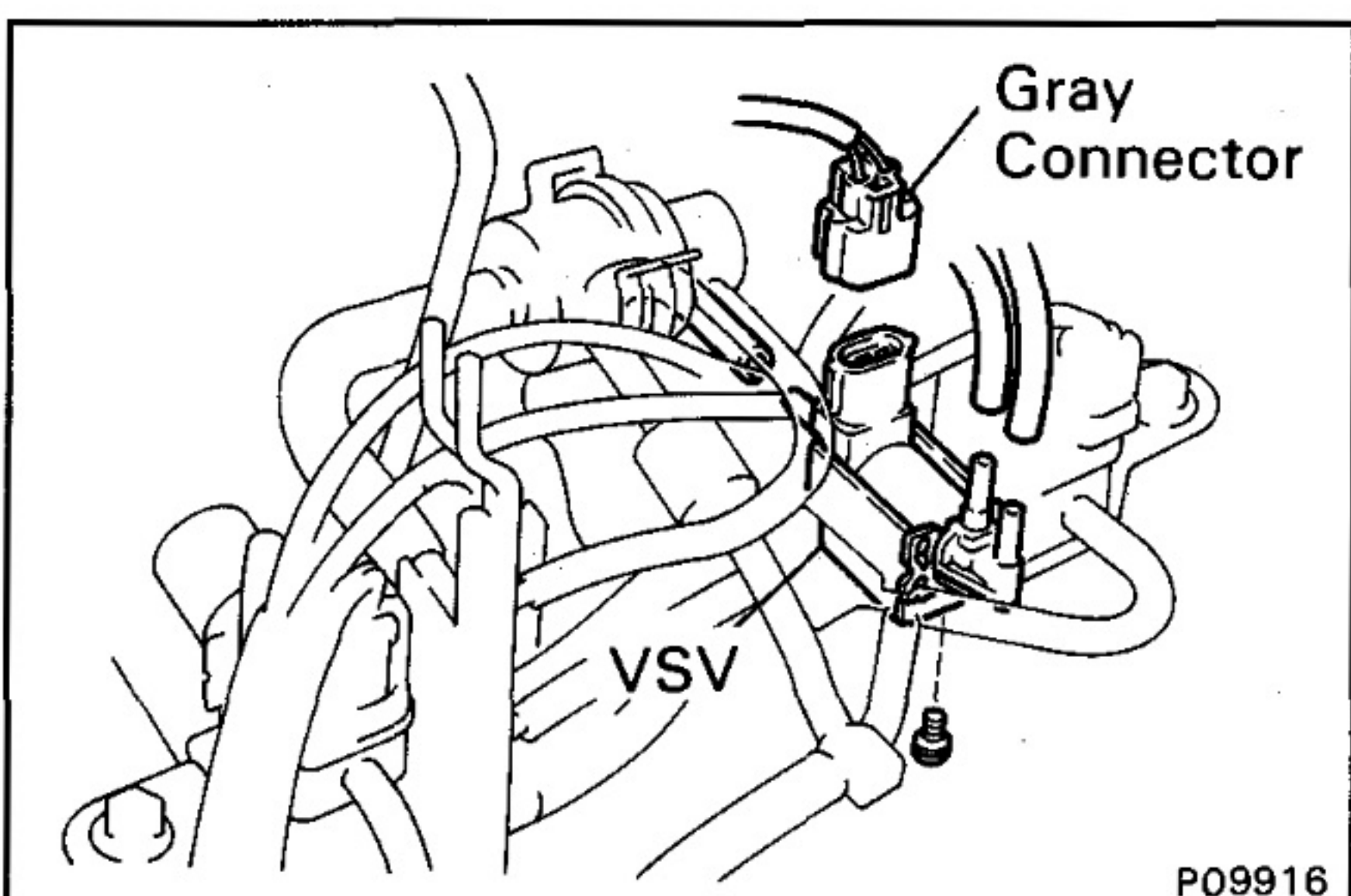

- (c) Disconnect the connector and three vacuum hoses, and remove the screw and VSV.

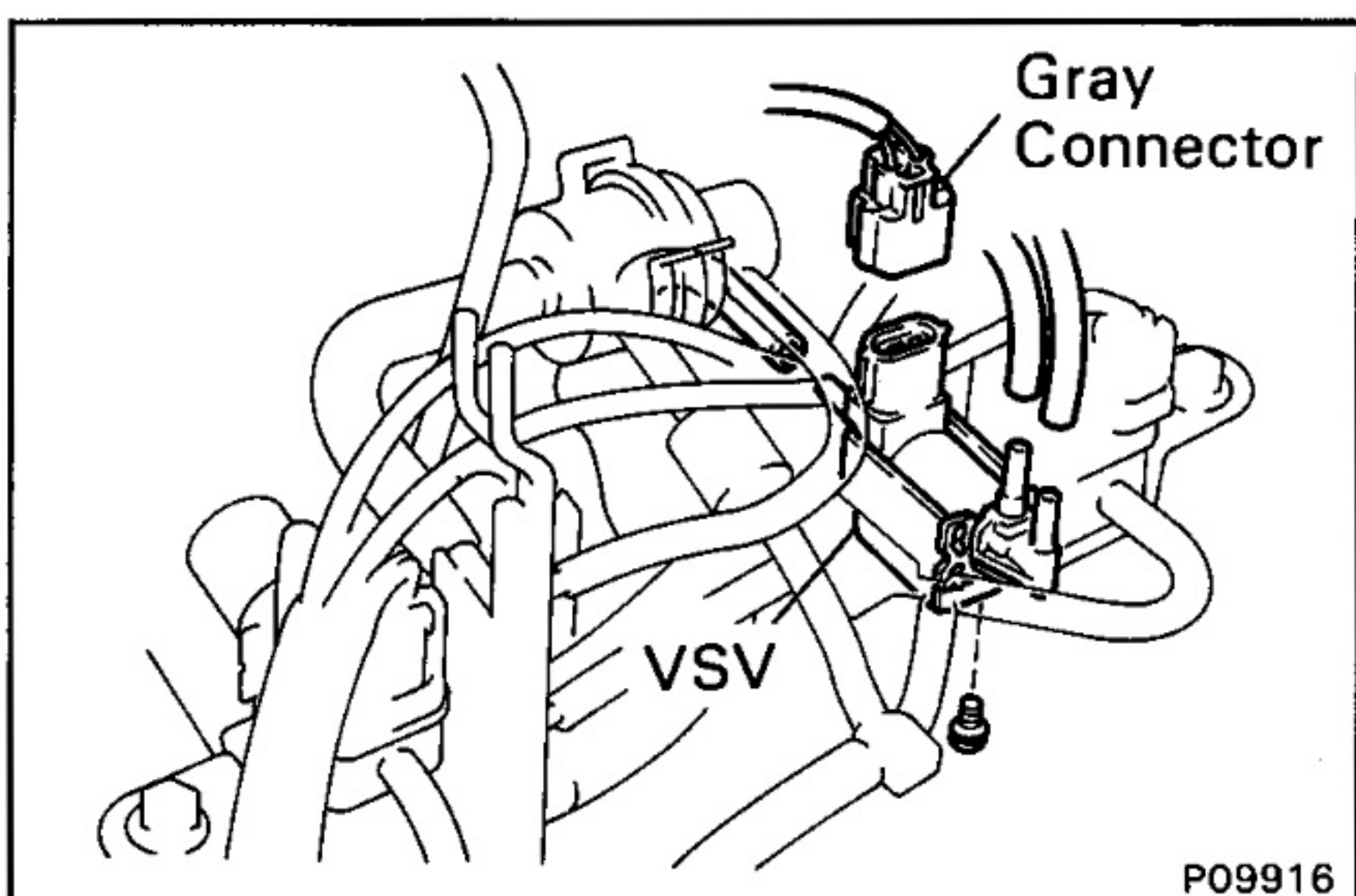
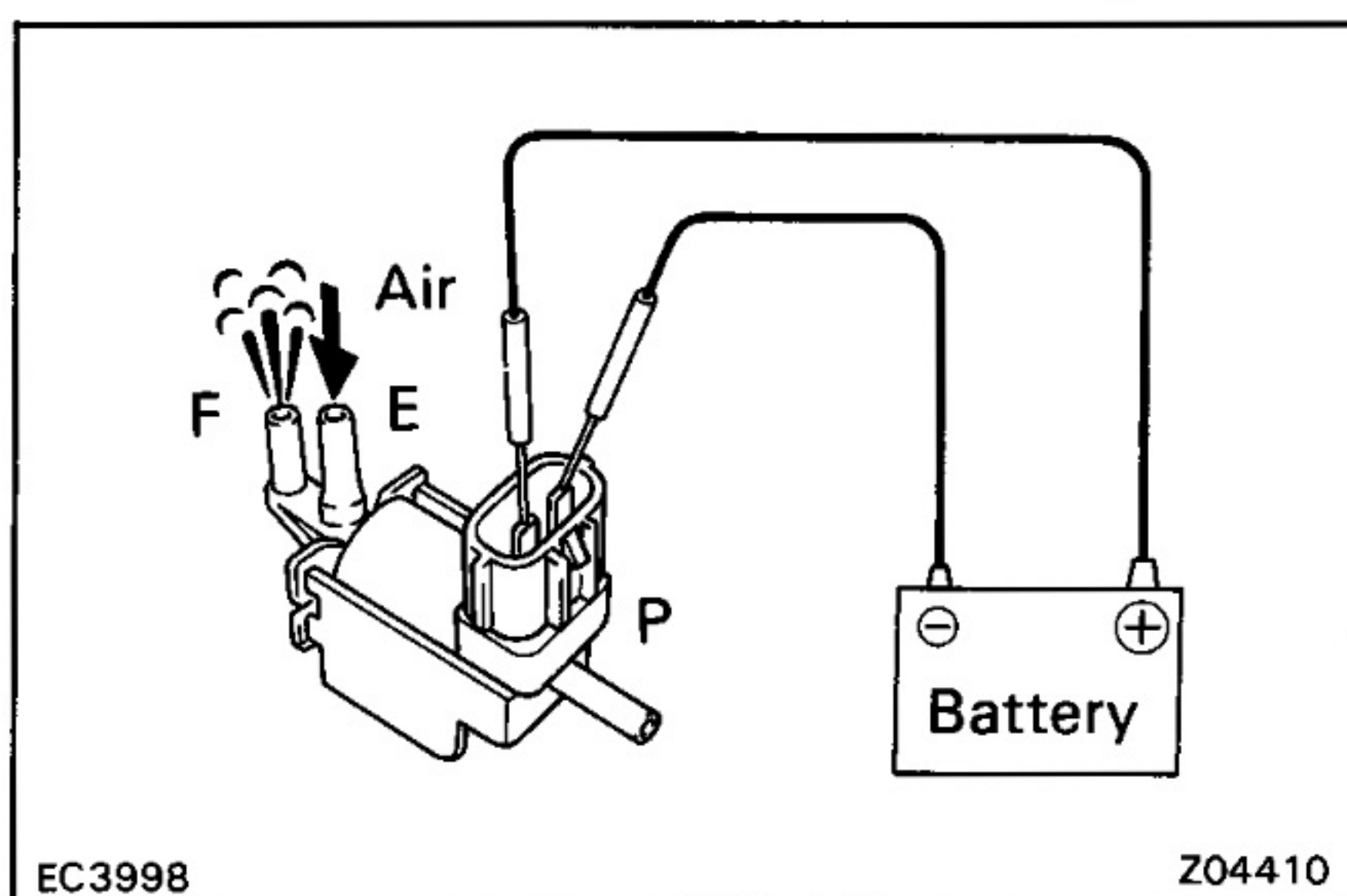
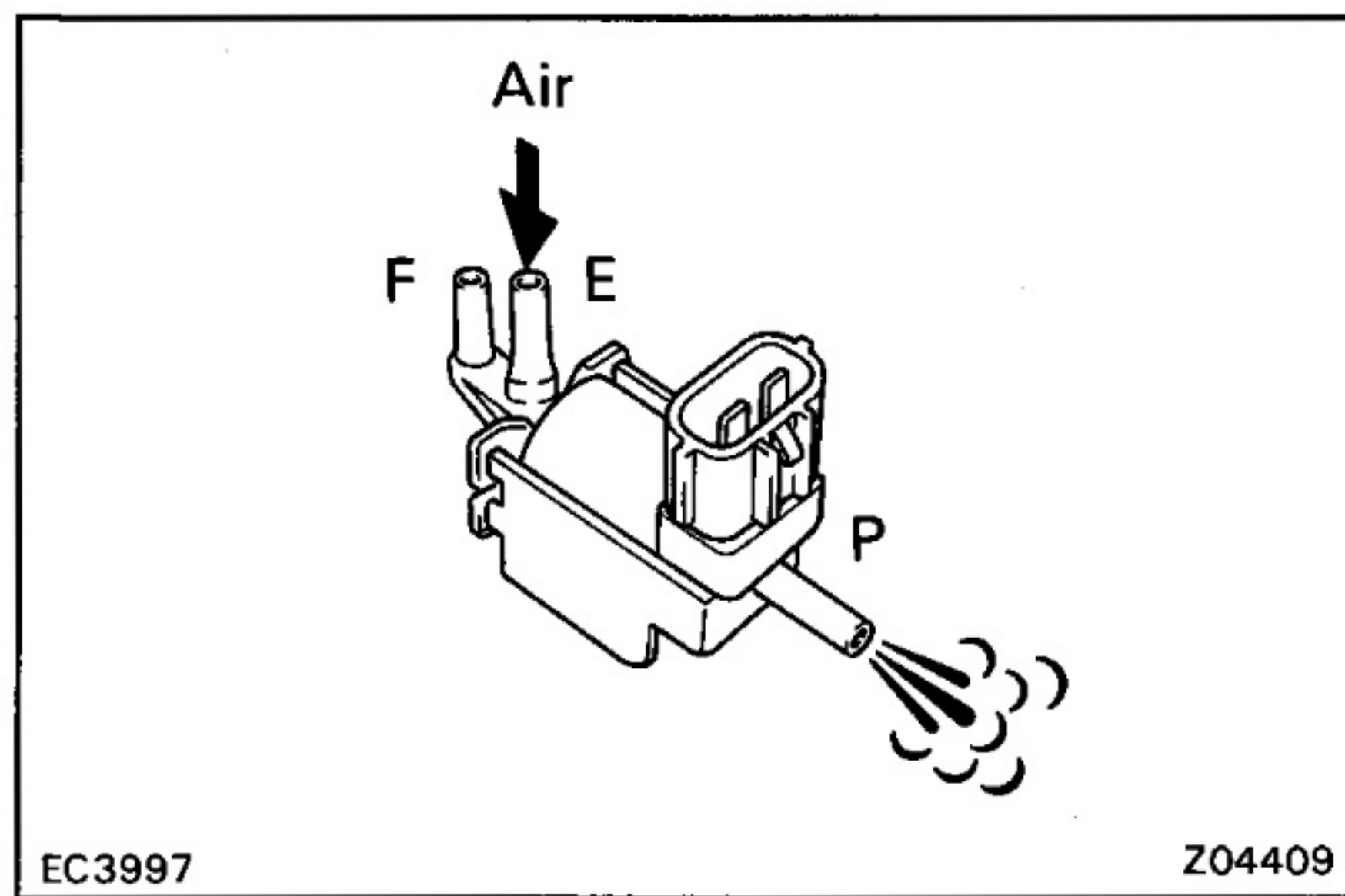
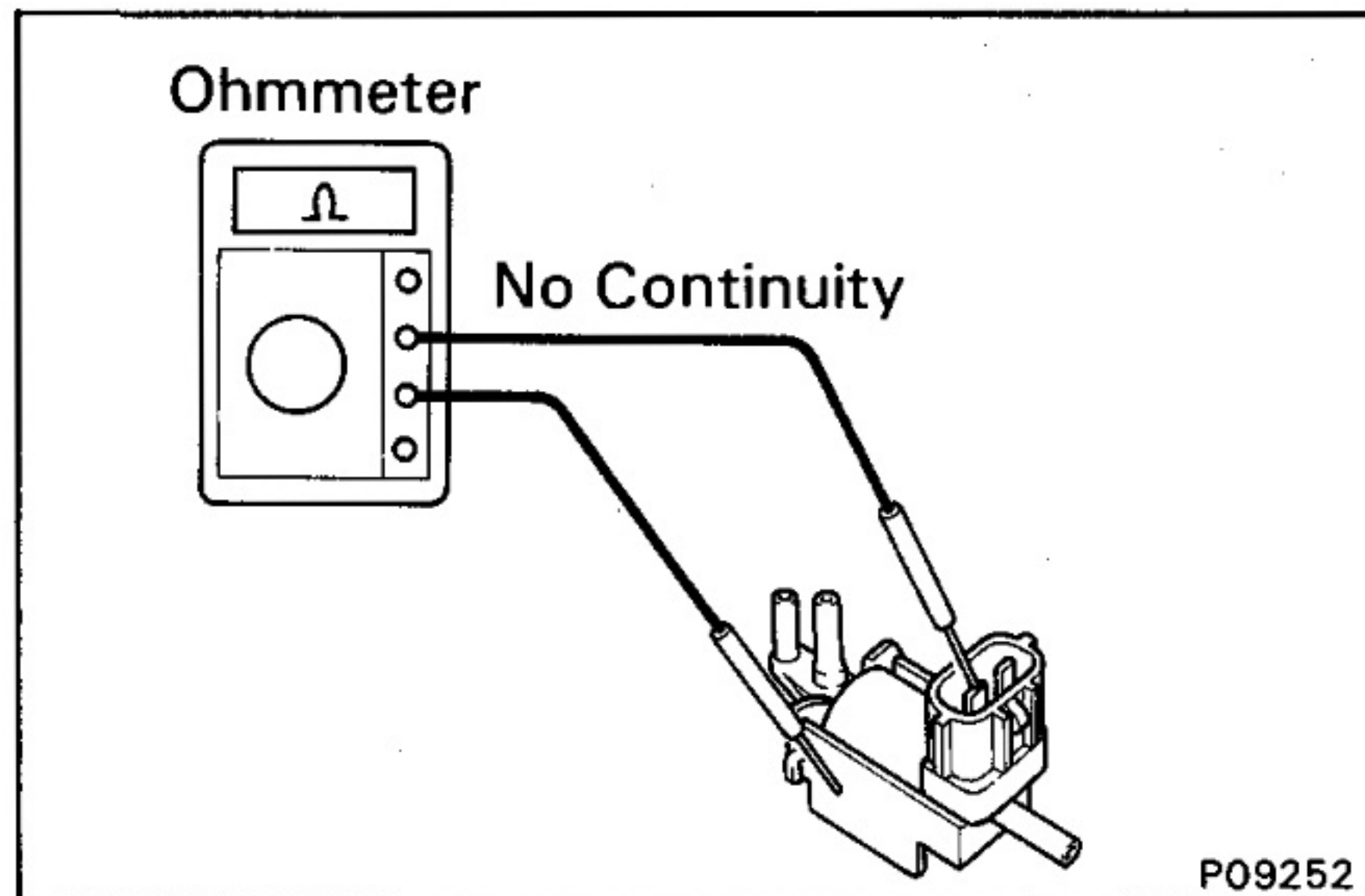
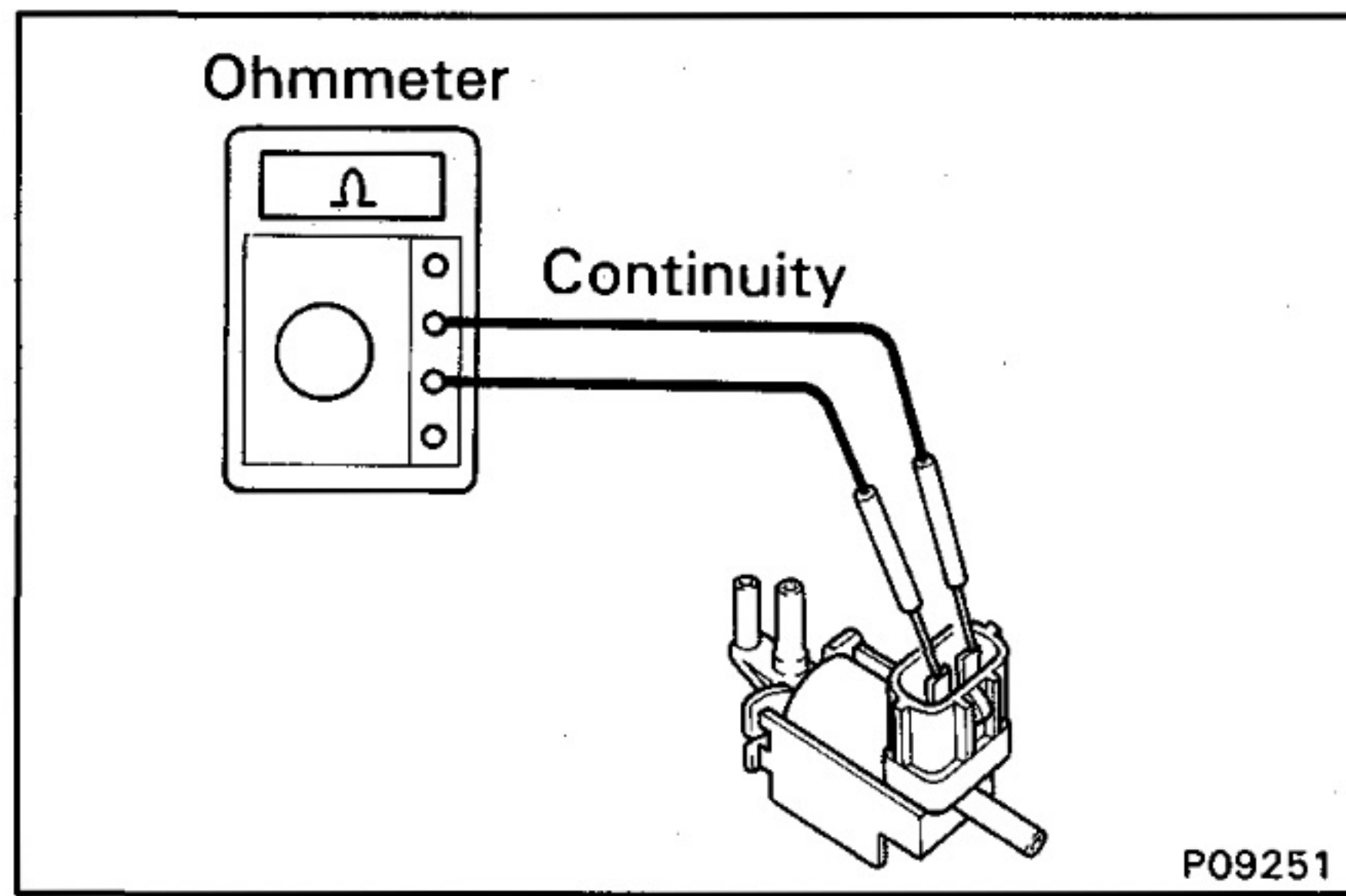

3. INSPECT VSV

A. Inspect VSV for open circuit

Using an ohmmeter, check that there is continuity between the terminals.

Resistance:

37 – 44 Ω at 20°C (68°F)

If there is no continuity, replace the VSV.

B. Inspect VSV for ground

Using an ohmmeter, check that there is no continuity between each terminal and the body.

If there is continuity, replace the VSV.

C. Inspect VSV operation

(a) Check that the air flows from pipe E to the pipe P.

(b) Apply battery voltage across the terminals.

(c) Check that the air flows from pipe E to pipe F.

If operation is not as specified, replace the VSV.

4. REINSTALL VSV

(a) Install the VSV with the screws.

(b) Connect the connector and three vacuum hoses to the VSV.

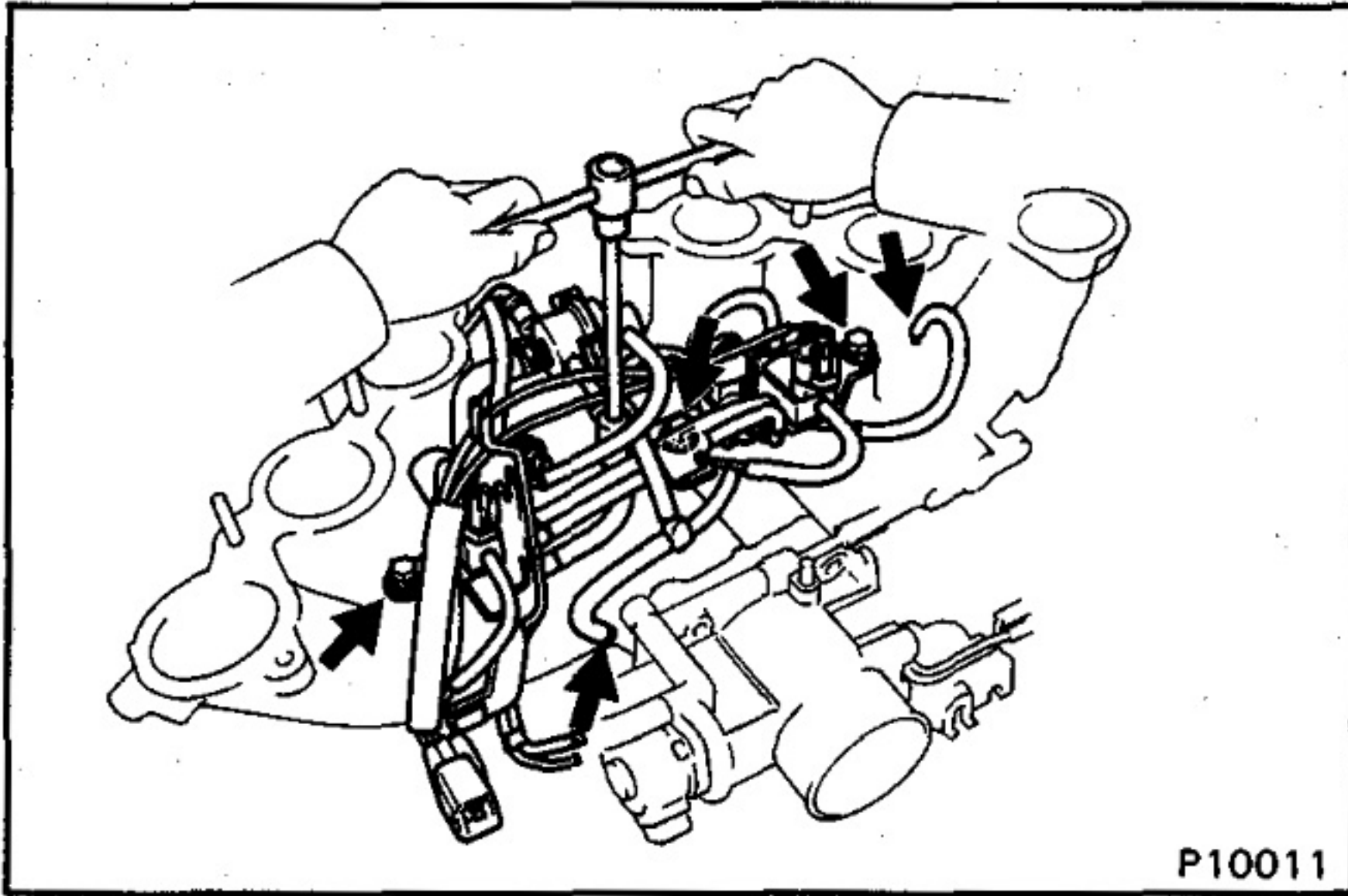

- (c) Install the emission control valve set assembly with the four bolts.

Torque: 20 N·m (200 kgf·cm, 14 ft·lbf)

- (d) Connect the air hose and vacuum hose to the air intake chamber.

5. REINSTALL AIR INTAKE CHAMBER

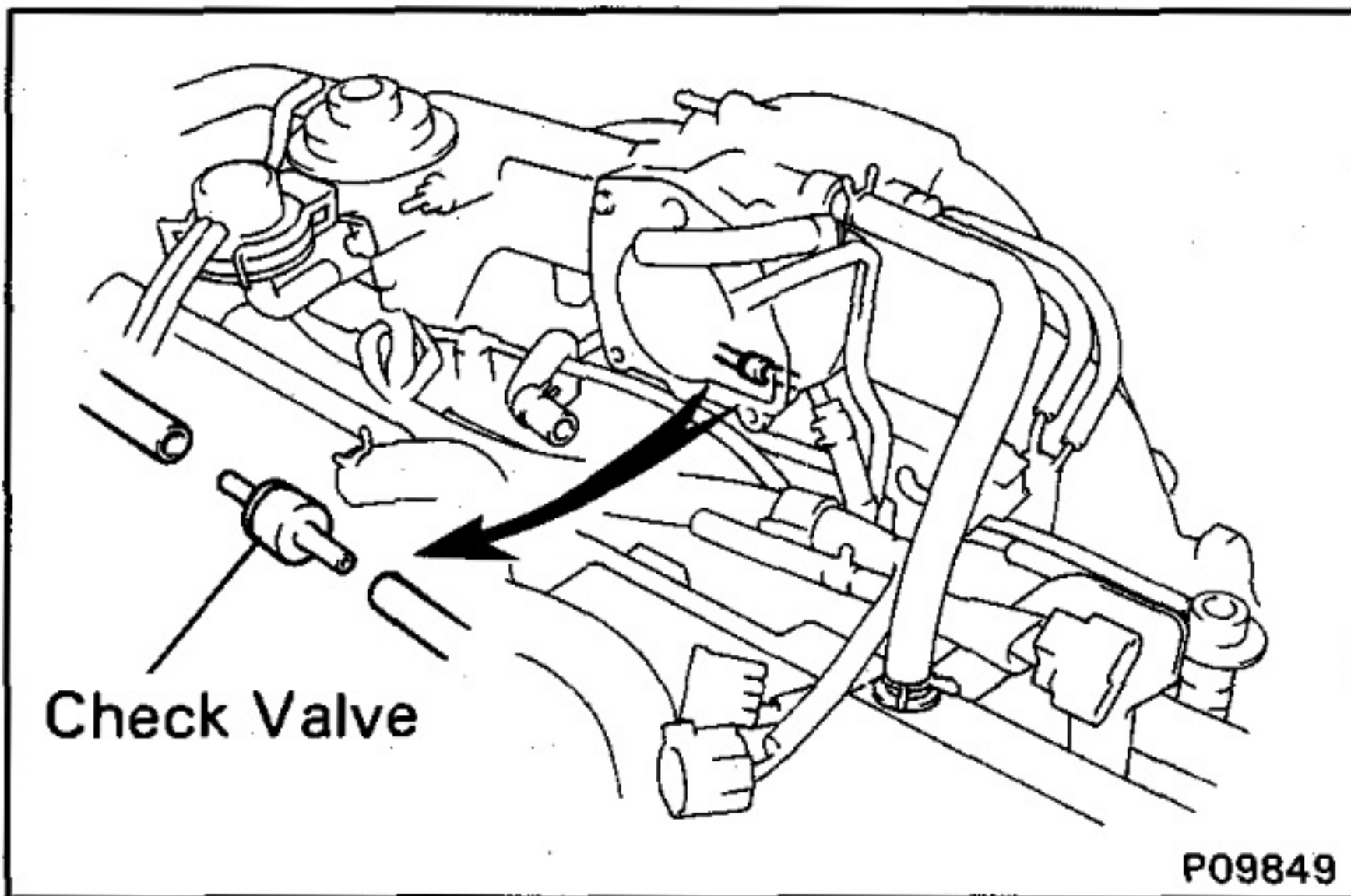

INSPECTION OF CHECK VALVE

1. REMOVE THROTTLE BODY

2. REMOVE CHECK VALVE

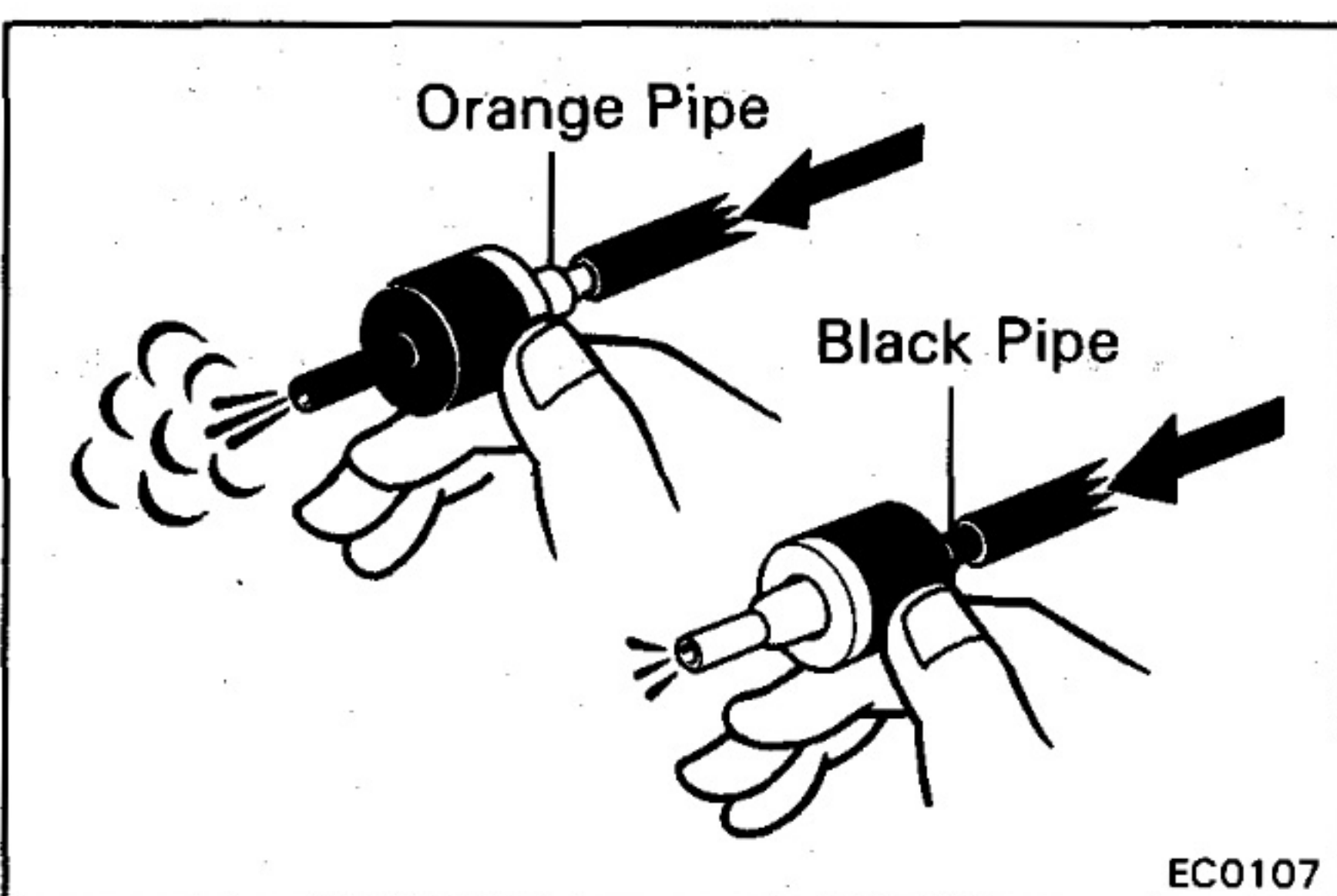

3. INSPECT CHECK VALVE

- (a) Check that air flows from the orange pipe to the black pipe.
 (b) Check that air does not flow from the black pipe to the orange pipe.

If operation is not as specified, replace the check valve.

4. REINSTALL CHECK VALVE

HINT: Reinstall the check valve with the black pipe facing front of the vehicle.

5. REINSTALL THROTTLE BODY

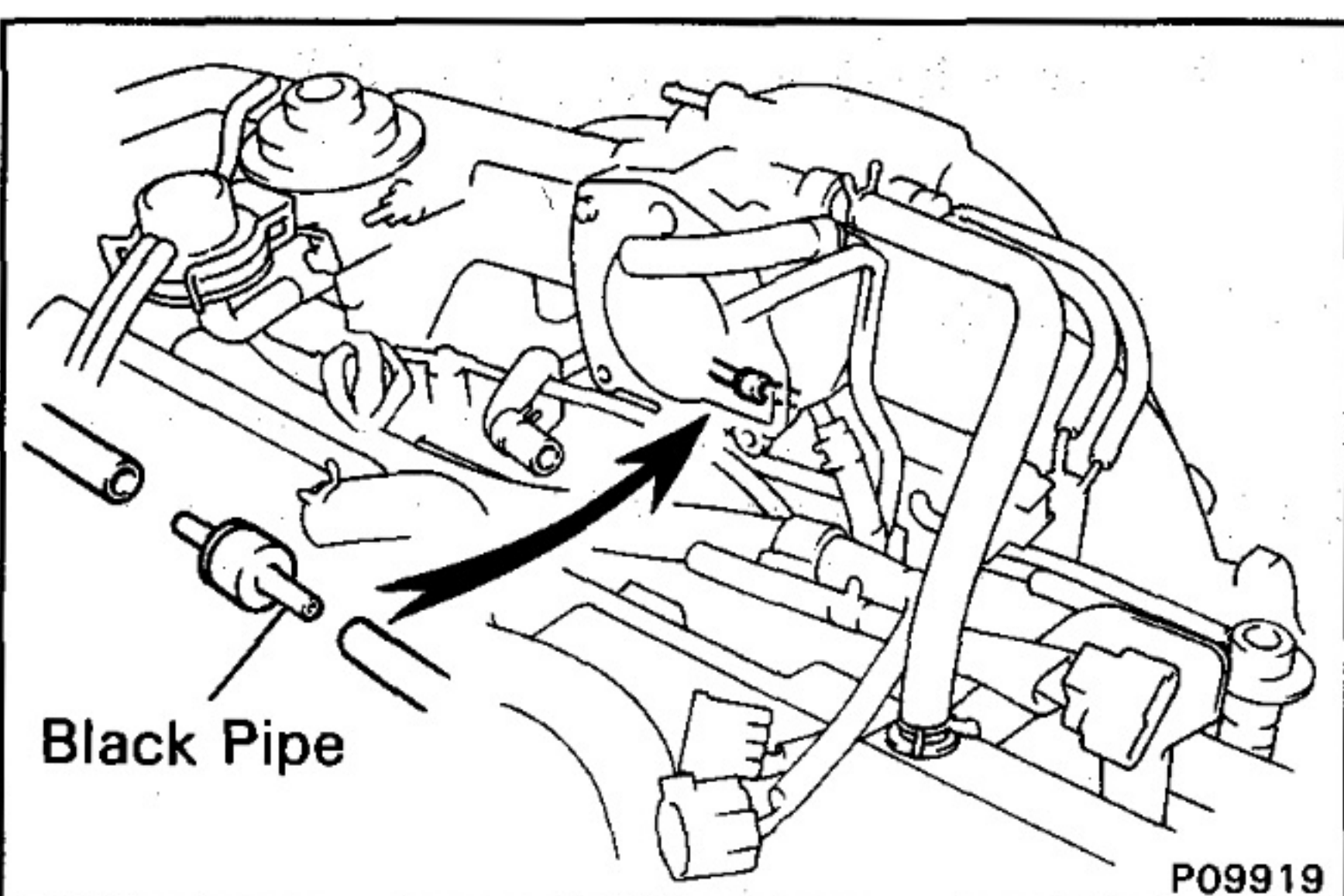

THREE-WAY CATALYTIC CONVERTER (TWC) SYSTEM

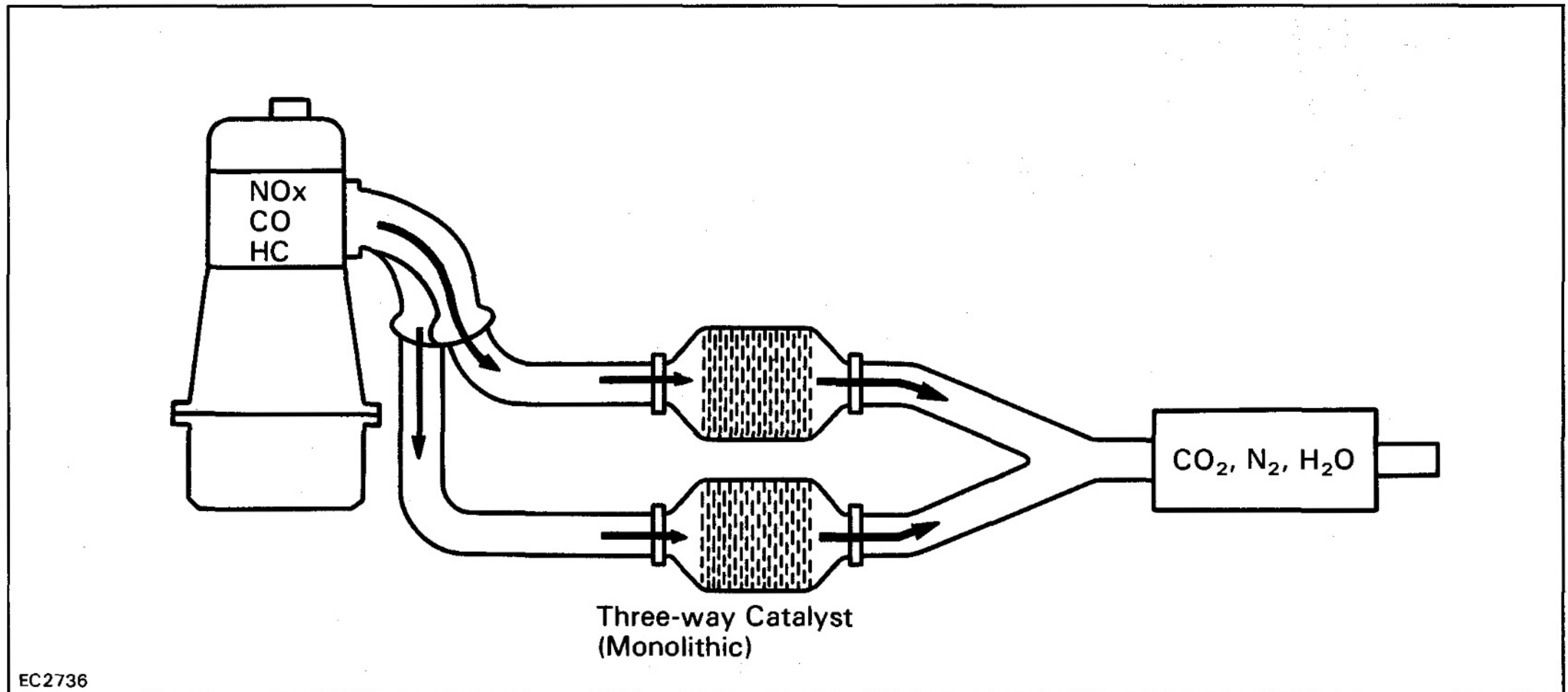

To reduce CO, HC and NOx emissions, they are oxidized, reduced and converted to nitrogen (N₂), carbon dioxide (CO₂) and water (H₂O) by the catalyst.

Exhaust Port		TWC		Exhaust Gas
HC, CO and NOx	→	Oxidation and reduction	→	CO ₂ H ₂ O N ₂

INSPECTION OF EXHAUST PIPE ASSEMBLY

1. CHECK CONNECTIONS FOR LOOSENESS OR DAMAGE
2. CHECK CLAMPS FOR WEAKNESS, CRACKS OR DAMAGE

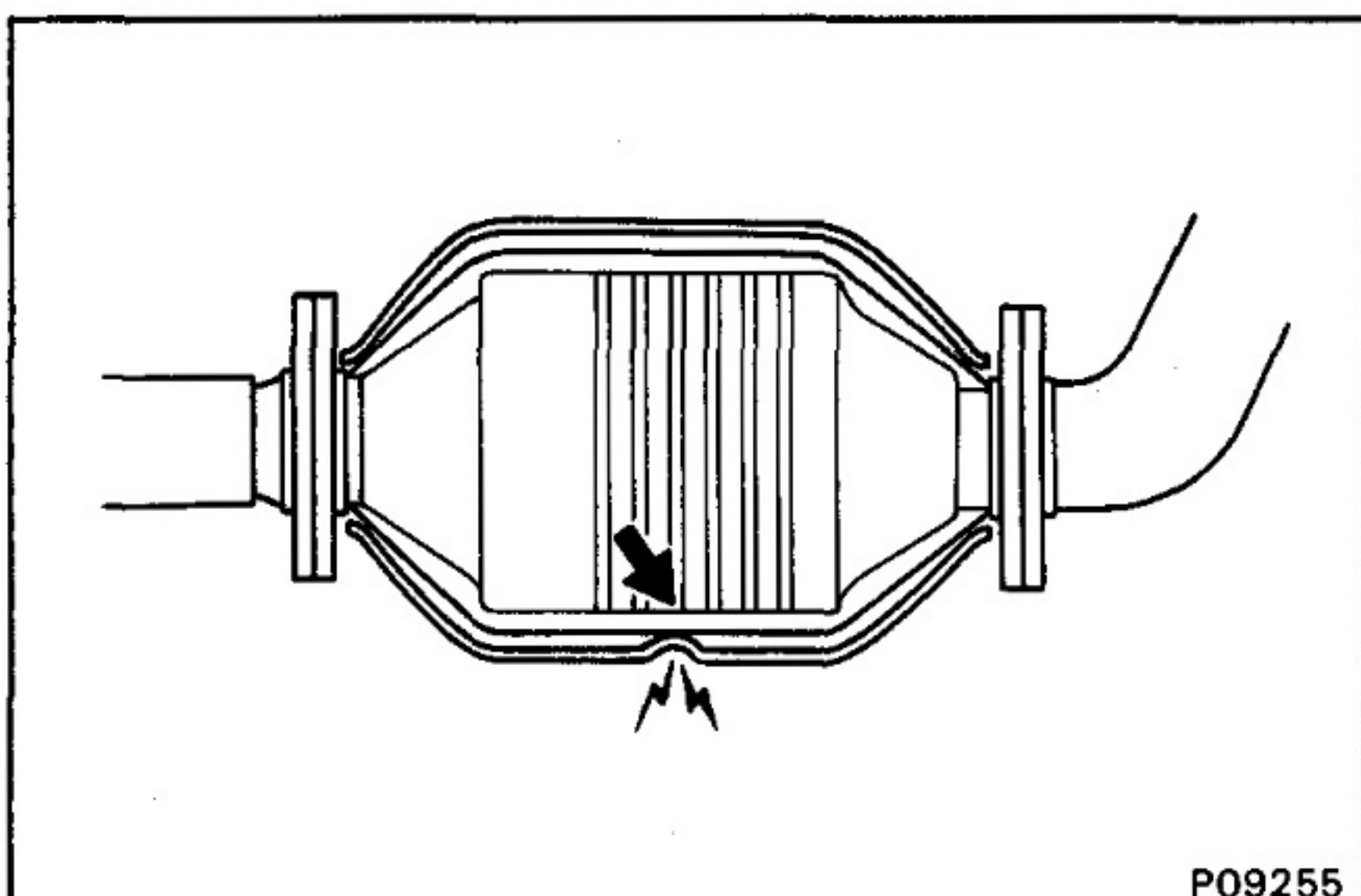

INSPECTION OF THREE-WAY CATALYTIC CONVERTER

CHECK FOR DENTS OR DAMAGE

If any part of the protector is damaged or dented to the extent that it touches the converter, repair or replace it.

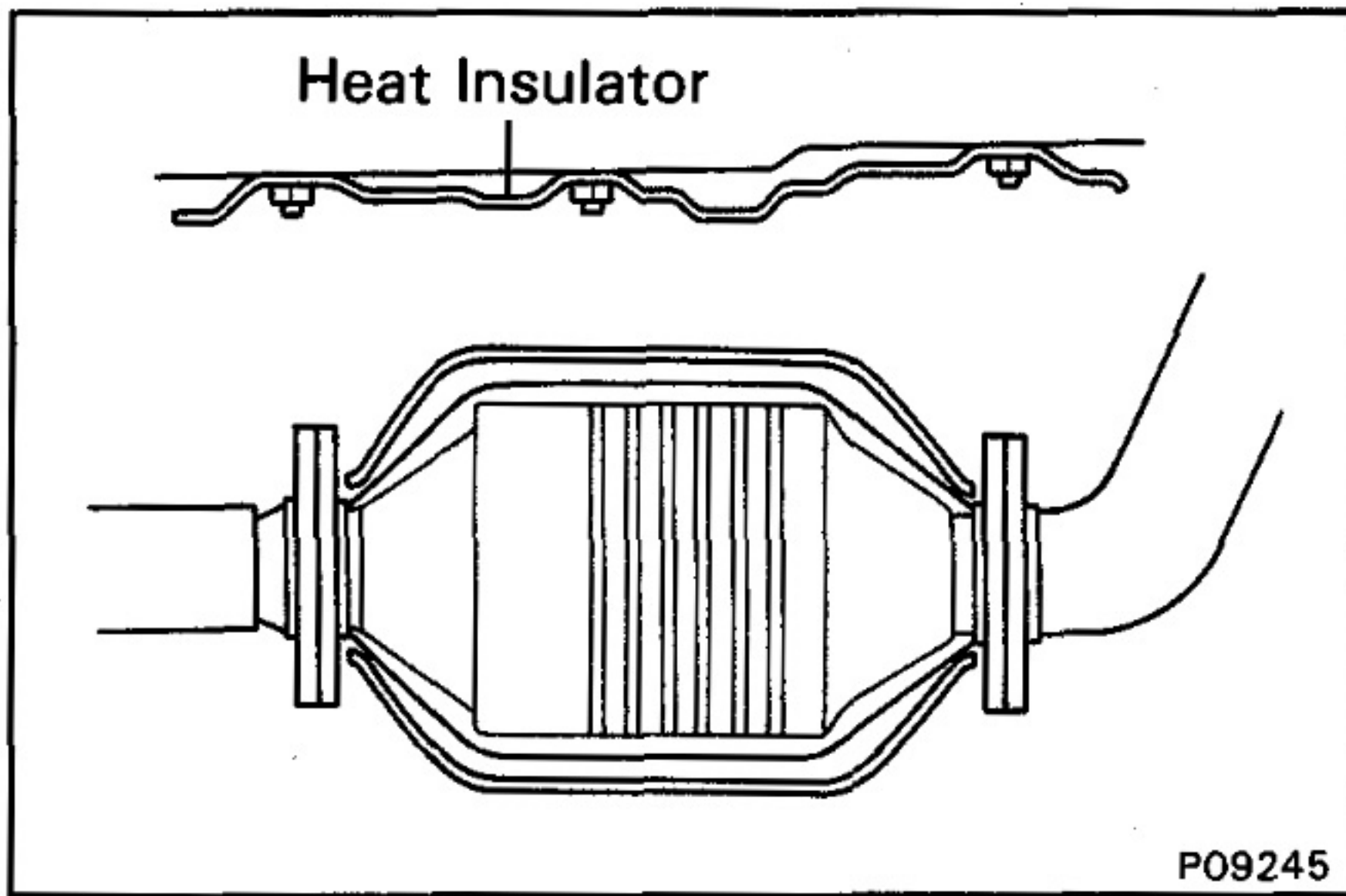

INSPECTION OF HEAT INSULATOR

1. CHECK HEAT INSULATOR FOR DAMAGE
2. CHECK FOR ADEQUATE CLEARANCE BETWEEN CATALYTIC CONVERTER AND HEAT INSULATOR

COMPONENTS FOR THREE-WAY CATALYTIC CONVERTERS

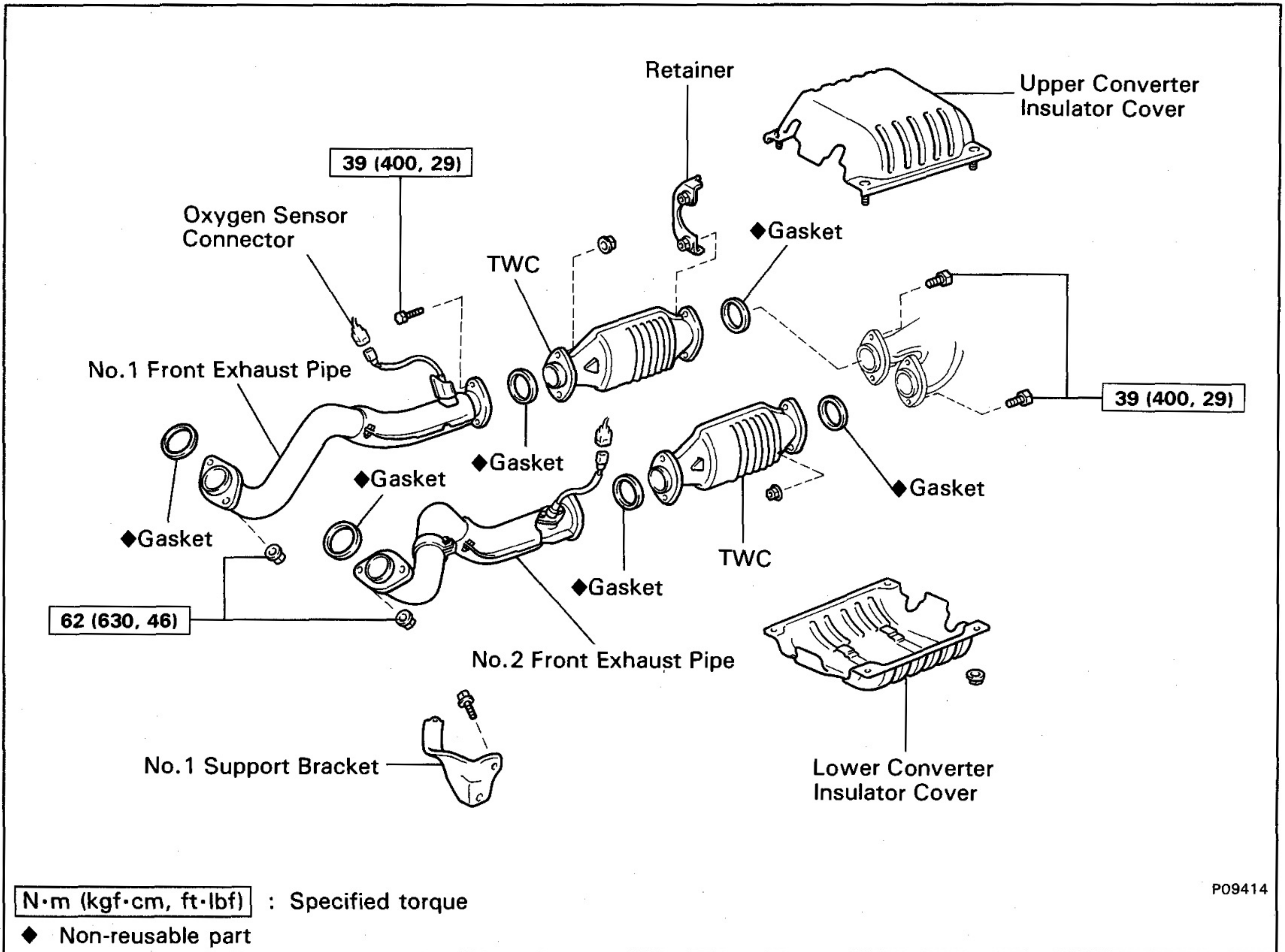

N·m (kgf·cm, ft·lbf) : Specified torque

◆ Non-reusable part

ENGINE ADJUSTMENT

IGNITION TIMING 4-2
IDLE SPEED 4-3
OXYGEN SENSOR CHECK 4-4
IDLE CO/HC CONCENTRATION CHECK 4-5

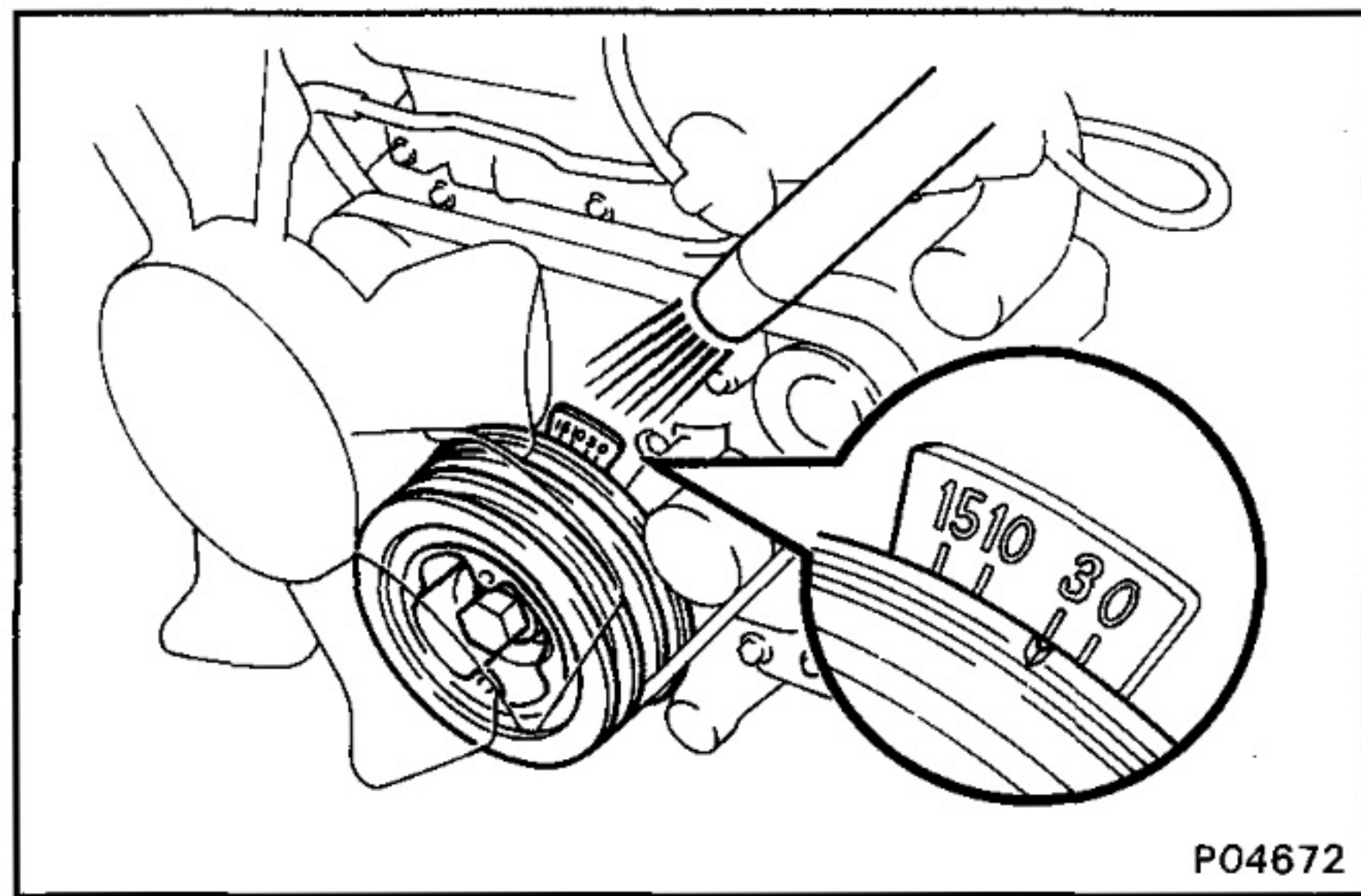
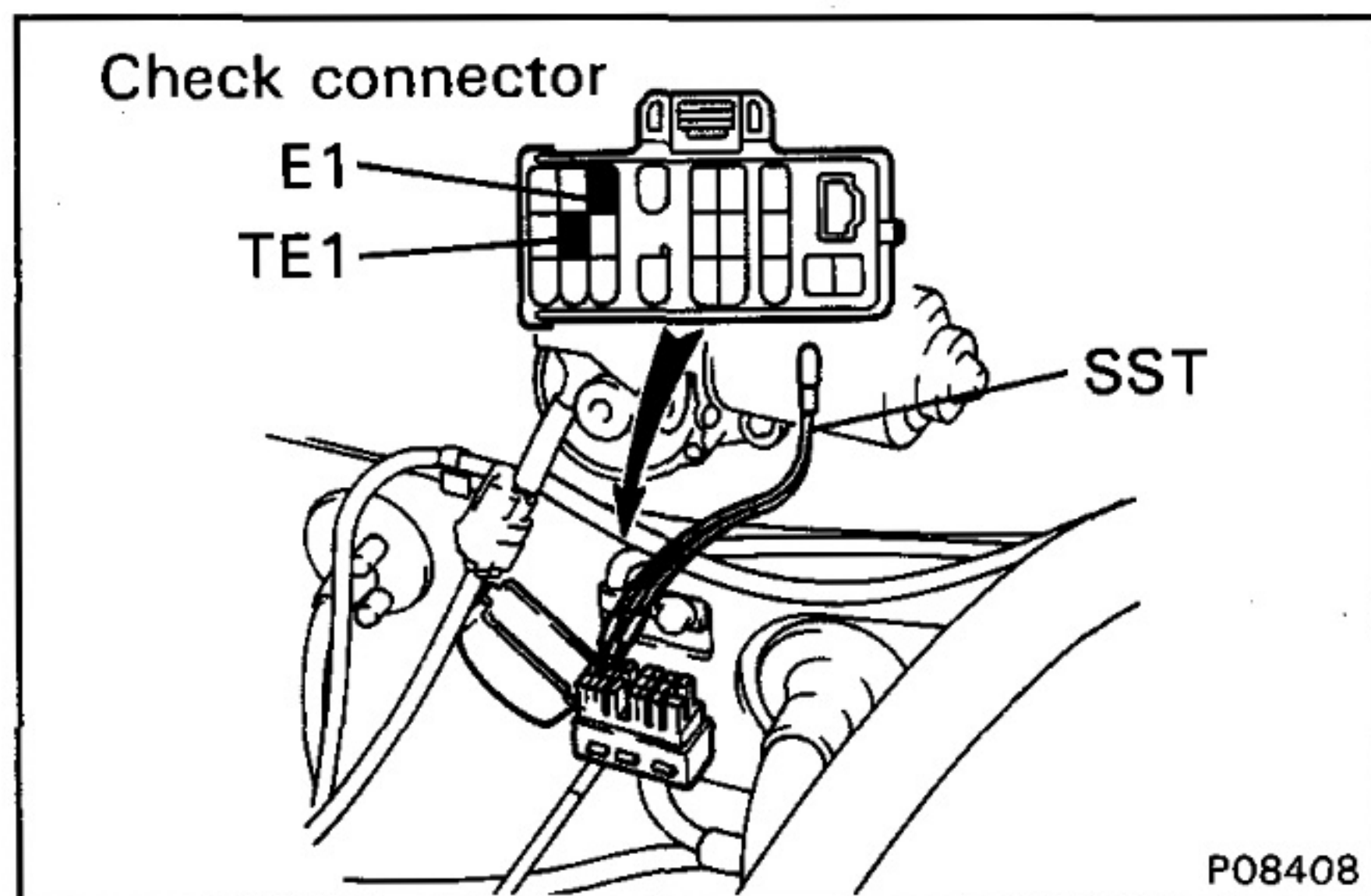
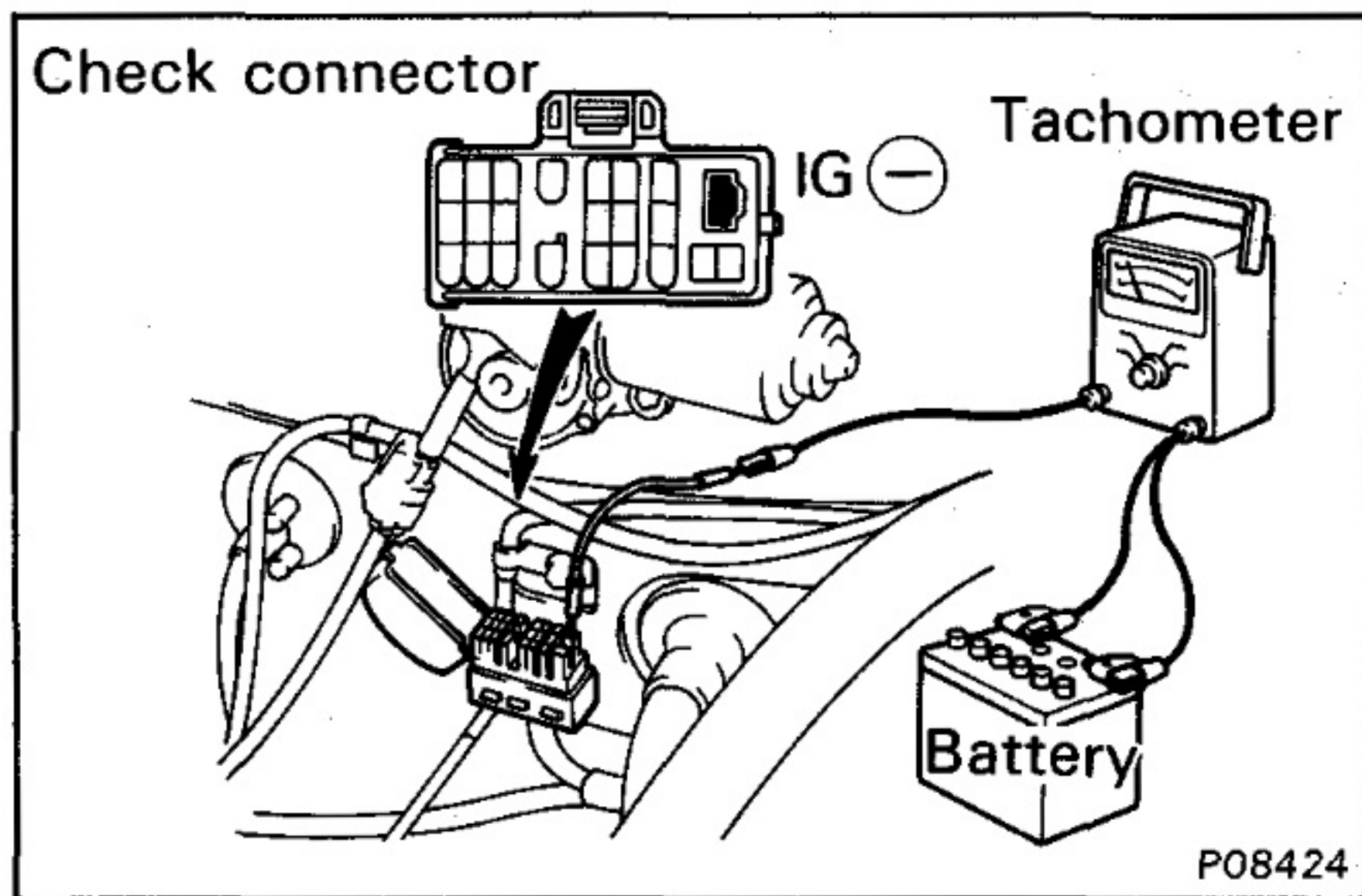

IGNITION TIMING

INSPECTION AND ADJUSTMENT OF IGNITION TIMING

1. WARM ENGINE UP

Allow the engine to reach normal operating temperature.

2. CONNECT TACHOMETER AND TIMING LIGHT TO ENGINE

- (a) Connect the tachometer test probe to terminal IG ⊖ of the check connector.

NOTICE:

- NEVER allow the tachometer terminals to touch ground as it could result in damage to the igniter and/or ignition coil.
- As some tachometers are not compatible with this ignition system, we recommend that you confirm the compatibility of your unit before using.

- (b) Using SST, connect terminals TE1 and E1 of the check connector.

SST 09843-18020

3. INSPECT AND ADJUST IGNITION TIMING

- (a) With the engine idling as specified, use a timing light to check the timing.

Ignition timing:

$3^{\circ} \pm 2^{\circ}$ BTDC @ idle

(w/ Terminals TE1 and E1 connected).

If necessary, loosen the distributor bolt and turn the distributor to align the marks. Recheck the timing after tightening the distributor bolt.

Torque: 18 N·m (180 kgf·cm, 13 ft·lbf)

- (b) Disconnect SST
SST 09843-18020

4. FURTHER CHECK IGNITION TIMING

Check the ignition timing advance.

Ignition timing:

$2^{\circ} - 13^{\circ}$ BTDC @ idle

5. DISCONNECT TACHOMETER AND TIMING LIGHT FROM ENGINE

IDLE SPEED

INSPECTION OF IDLE SPEED

1. INITIAL CONDITIONS

- (a) Engine at reach normal operating temperature
 - (b) Air cleaner installed
 - (c) All pipes and hoses of air induction system connected
 - (d) All accessories switched OFF
 - (e) All vacuum lines properly connected
- HINT: All vacuum hoses should be properly connected.
- (f) EFI system wiring connectors fully plugged
 - (g) Ignition timing set correctly
 - (h) Transmission in neutral

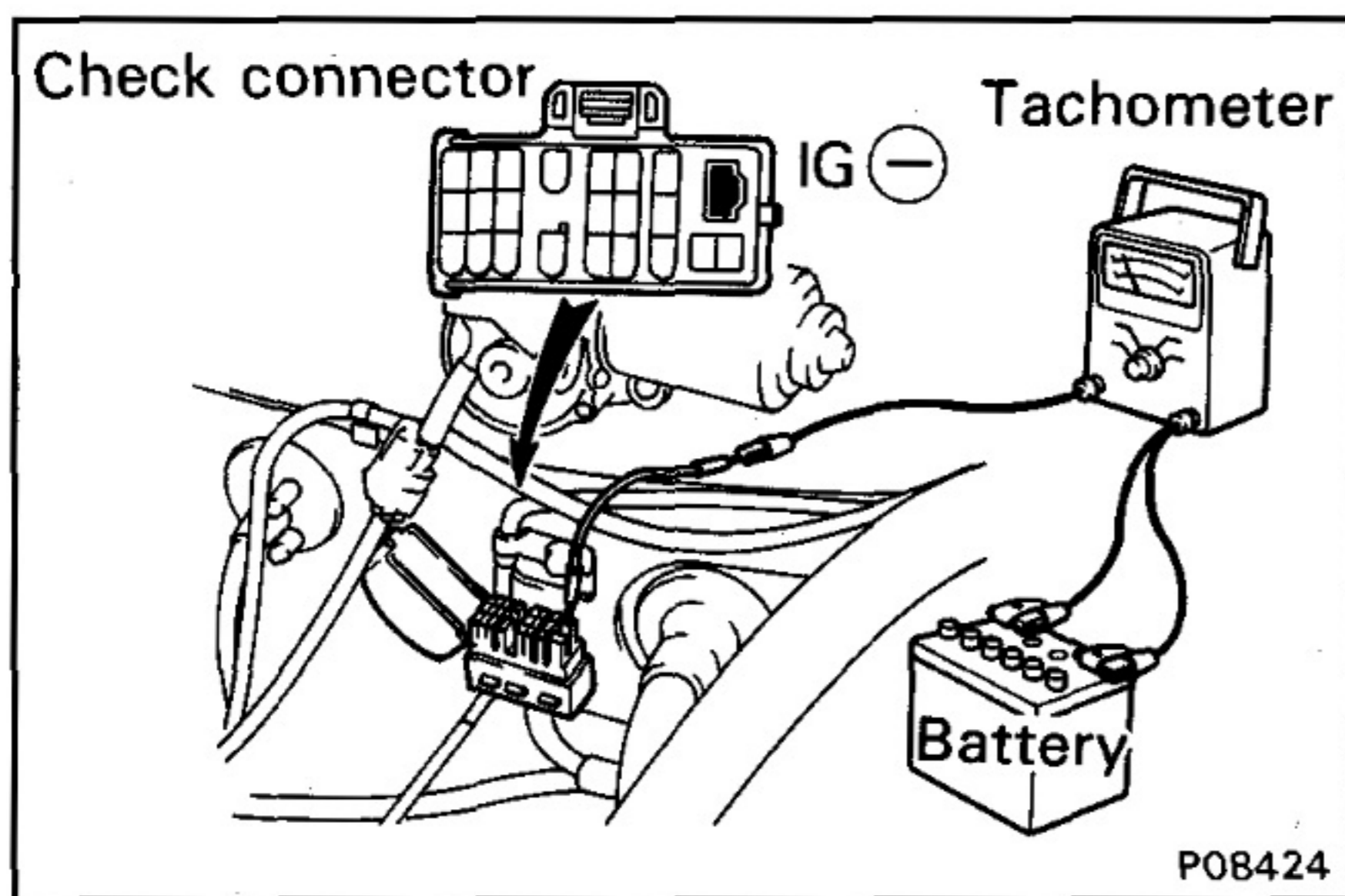

2. CONNECT TACHOMETER

3. START ENGINE

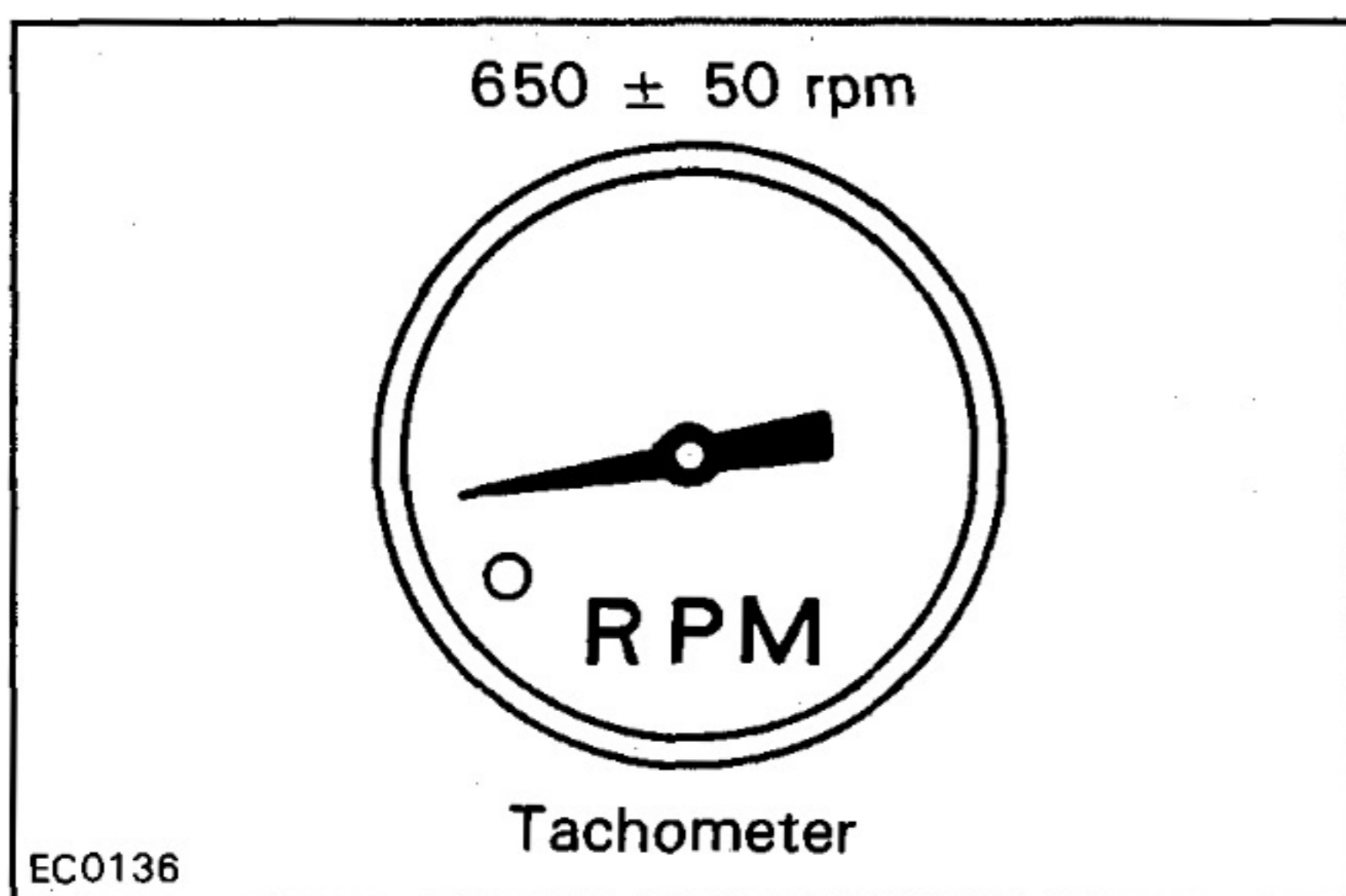

4. CHECK IDLE SPEED

- (a) Race the engine at 2,500 rpm for about 90 seconds.
 - (b) Check the idle speed.
- Idle speed:**
650 ± 50 rpm
- (c) If not as specified, check to the idle speed control system.

OXYGEN SENSOR CHECK

1. INITIAL CONDITIONS (See step 1 on page 4-3)
2. CONNECT TACHOMETER (See step 2 on page 4-3)
3. CHECK OXYGEN SENSOR OPERATION
 - (a) Disconnect the vacuum hose from the charcoal canister and plug the hose end.

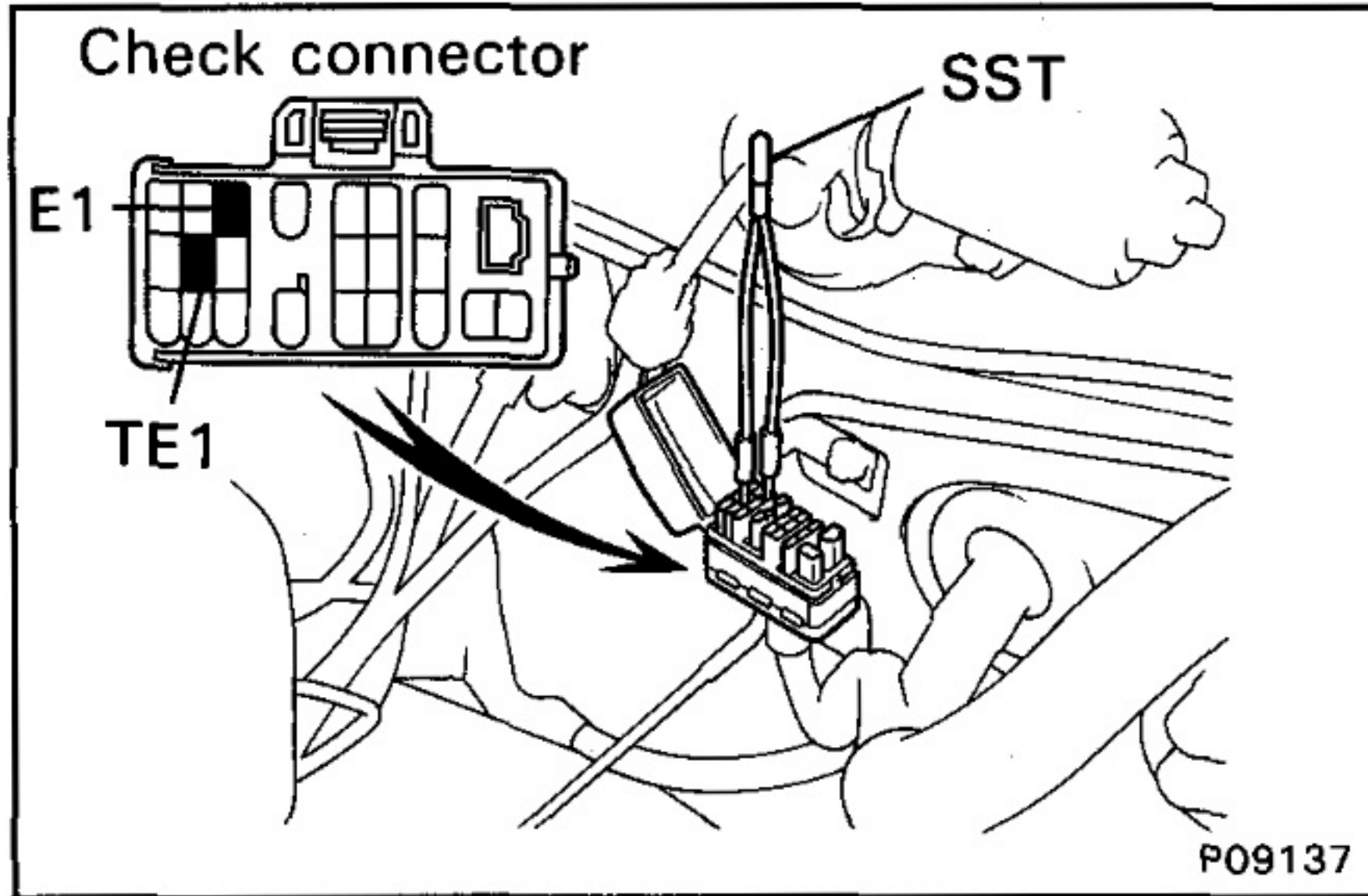

- (b) Using SST, connect the terminals TE1 and E1 of the check connector.
SST 09843-18020

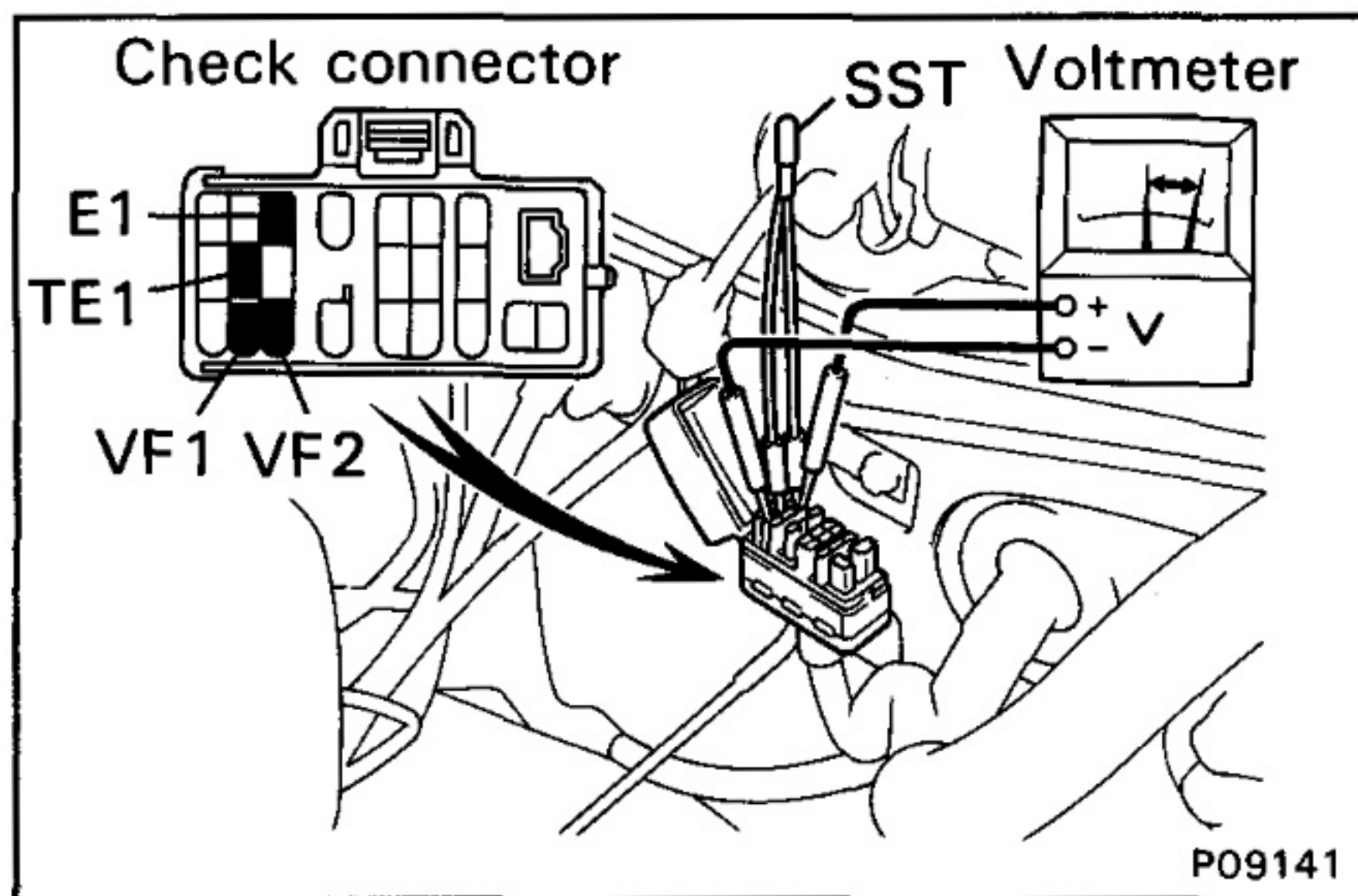

- (c) Connect the positive (+) tester probe of a voltmeter to terminal VF1 (VF2) of the check connector, and negative (-) tester probe to terminal E1.

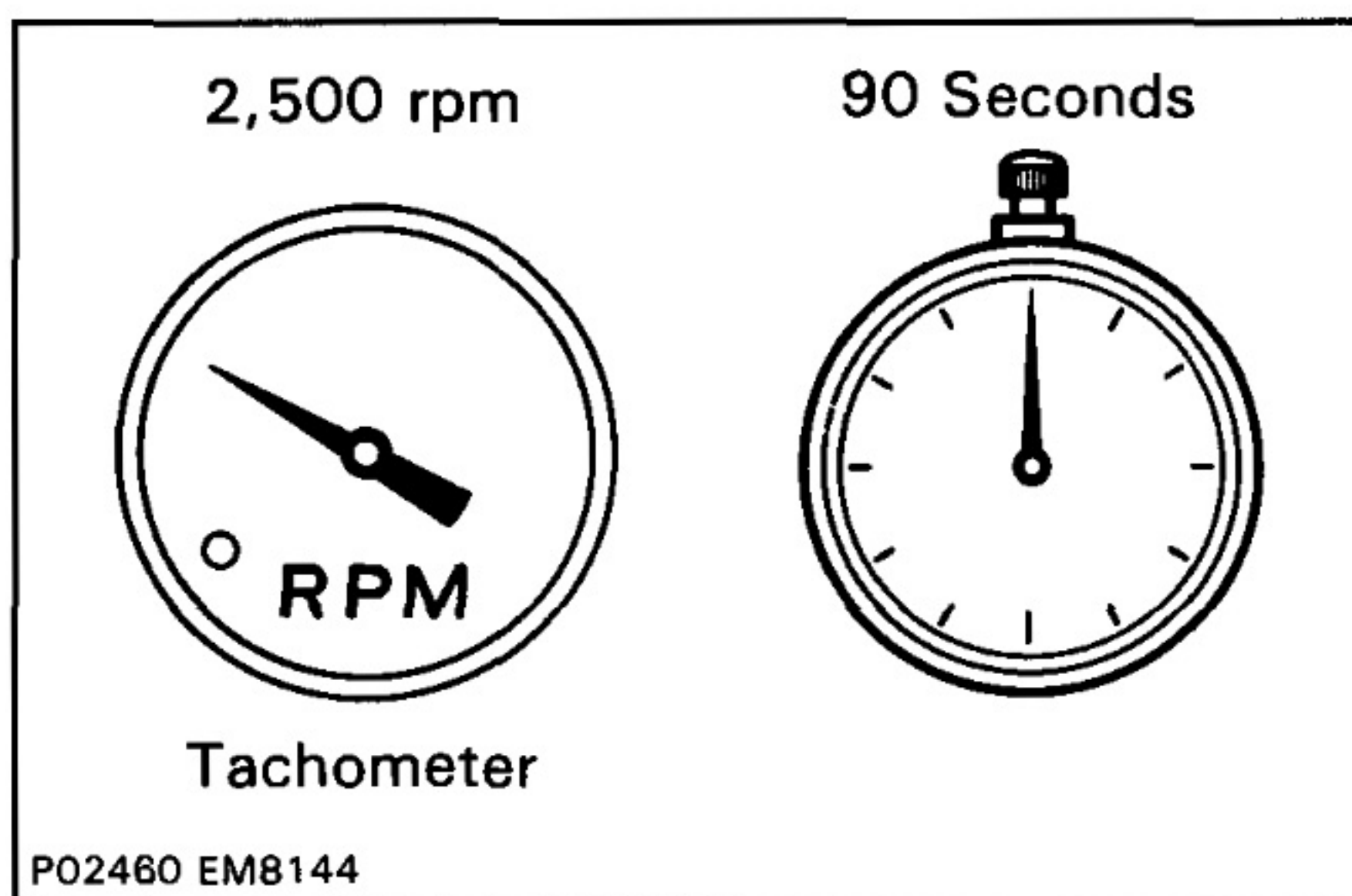

- (d) Hold the engine speed at 2,500 rpm for 90 seconds.

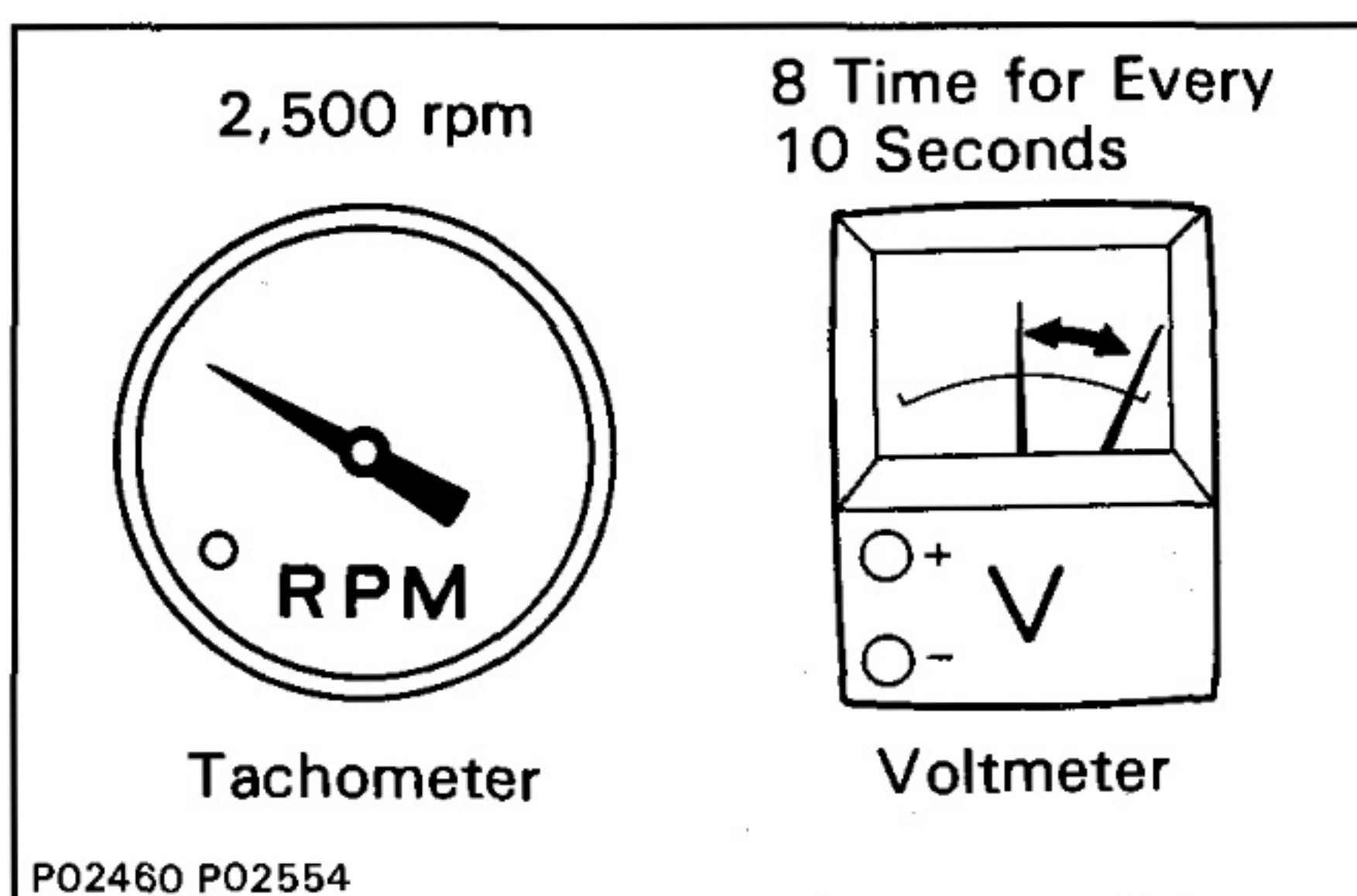

- (e) Then, maintaining engine at 2,500 rpm, count how many times needle of voltmeter fluctuates between 0 and 5 V.

**Minimum needle fluctuation:
8 times for every 10 seconds**

If the fluctuation is less than minimum, check the air induction system. If necessary, see EFI SYSTEM.

IDLE CO/HC CONCENTRATION CHECK

HINT: This check is used only to determine whether or not the idle CO/HC complies with regulations.

1. INITIAL CONDITIONS

- (a) Engine at normal operating temperature
- (b) Air cleaner installed
- (c) All pipes and hoses of air induction system connected
- (d) All accessories switched OFF
- (e) All vacuum lines properly connected

HINT: All vacuum hoses for EGR systems, etc. should be properly connected.

- (f) SFI system wiring connectors fully plugged
- (g) Ignition timing set correctly
- (h) Transmission in neutral position
- (i) Tachometer and CO/HC meter calibrated by hand

2. START ENGINE

3. RACE ENGINE AT 2,500 RPM FOR APPROX. 180 SECONDS

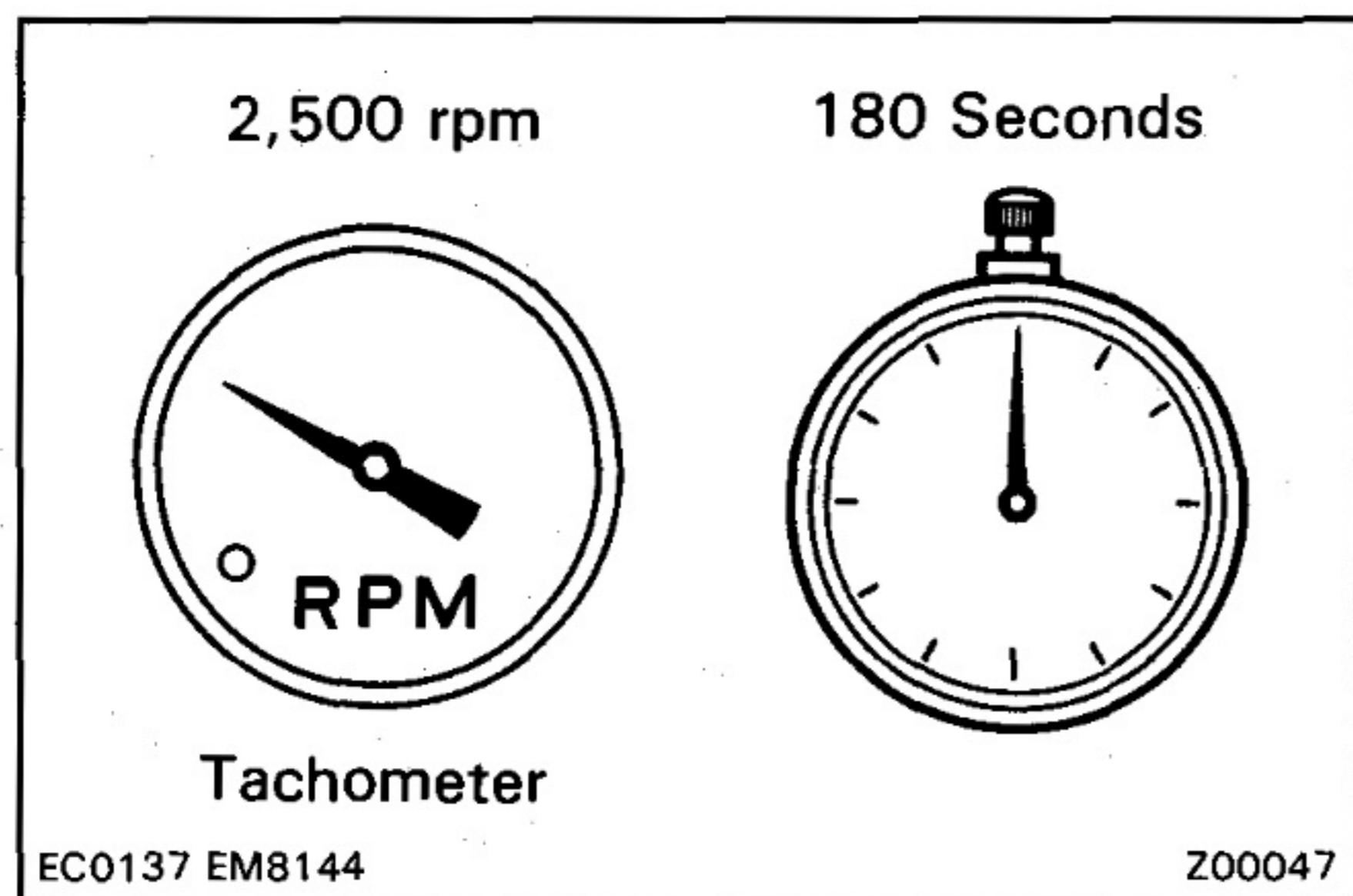

4. INSERT CO/HC METER TESTING PROBE INTO TAILPIPE AT LEAST 40 cm (1.3 ft) DURING IDLING

5. IMMEDIATELY CHECK CO/HC CONCENTRATION AT IDLE

HINT:

- When performing the test, follow the measurement order prescribed by the applicable local regulations.
- If the measurement order is against the regulations, perform troubleshooting (See page 4-6)

(Reference)

Idle CO: 1.5 ± 0.5 % (Middle East and General)

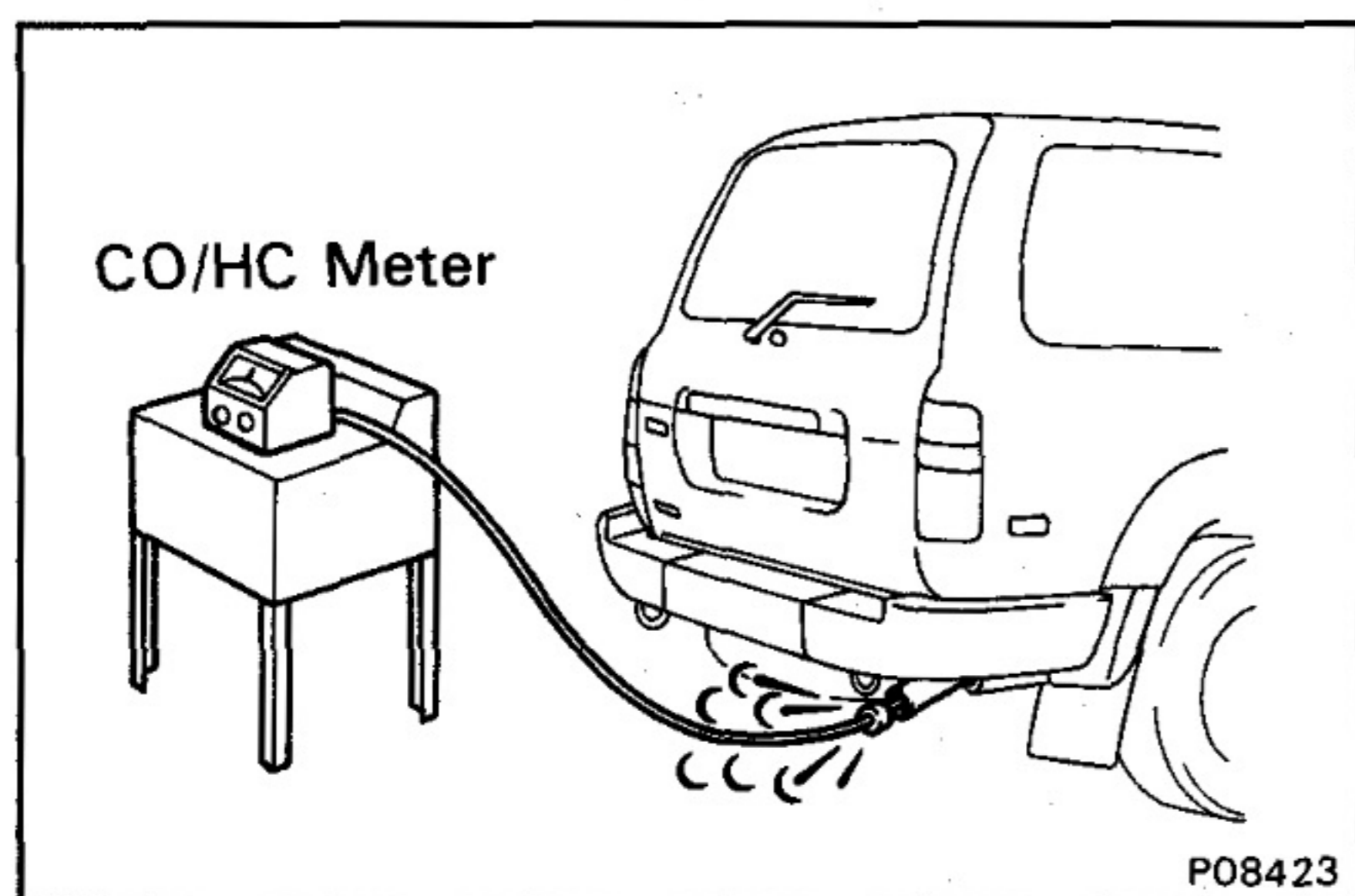

Troubleshooting (Ex. GCC, General)

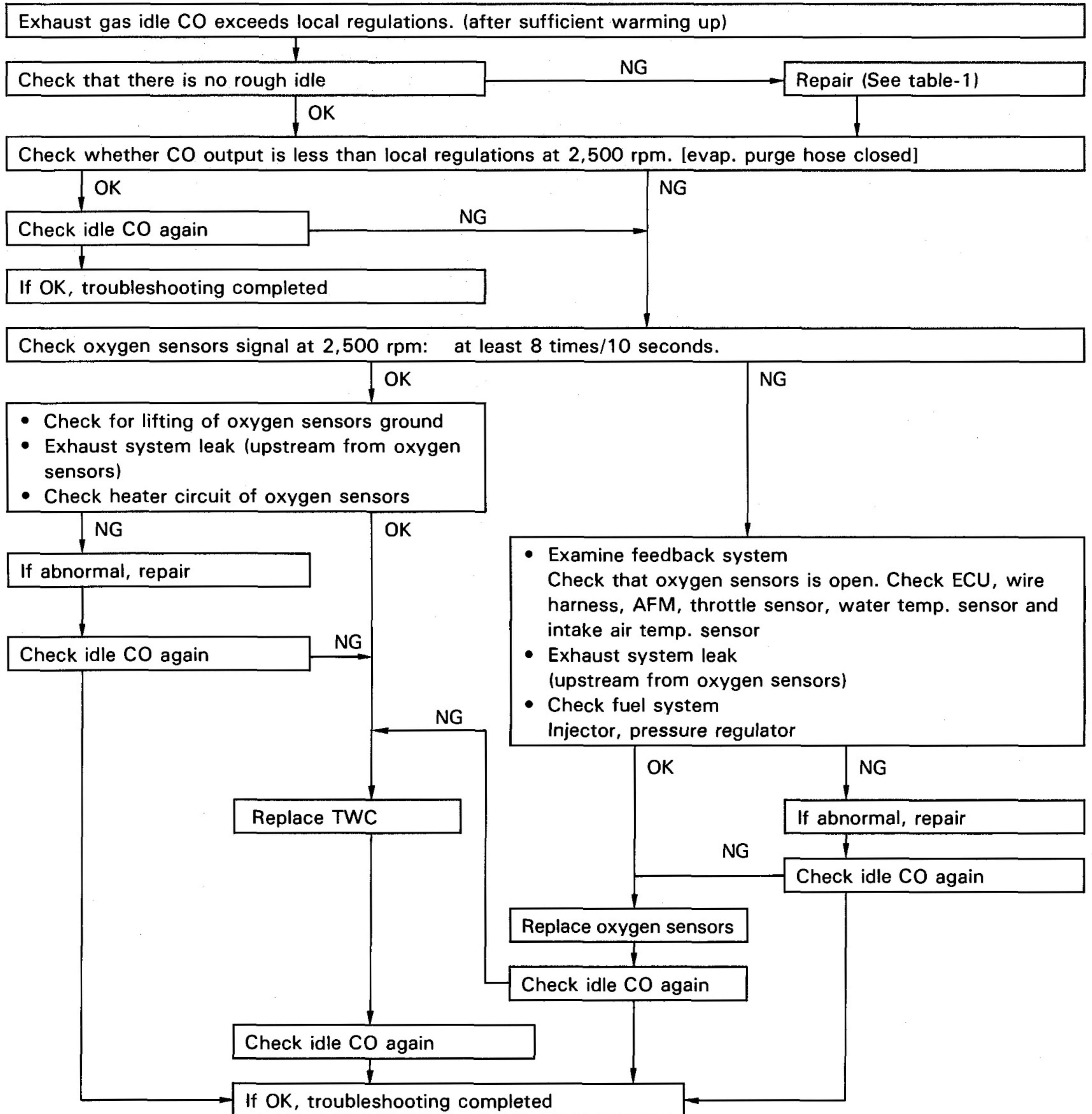

For details of how to perform each of the above checks, refer to the engine repair manual.

Table-1

HC	CO	Symptom	Cause
High	Normal	Rough idle	<ol style="list-style-type: none"> 1. Faulty ignition: <ul style="list-style-type: none"> • Incorrect timing • Fouled, shorted or improperly gapped plugs • Open or crossed high-tension cords • Cracked distributor cap 2. Incorrect valve clearance 3. Leaky EGR valve 4. Leaky intake and exhaust valves 5. Leaky cylinder
High	Low	Rough idle (Fluctuating HC reading)	<ol style="list-style-type: none"> 1. Vacuum leak: <ul style="list-style-type: none"> • PCV hose • EGR valve • Intake manifold • Air intake chamber • Throttle body • ISC valve • Brake booster line 2. Lean mixture causing misfire
High	High	Rough idle (Black smoke from exhaust)	<ol style="list-style-type: none"> 1. Restricted air filter 2. Faulty EFI system <ul style="list-style-type: none"> • Faulty pressure regulator • Clogged fuel return line • Defective water temp. sensor • Defective air temp. sensor • Faulty ECU • Faulty injector • Faulty throttle position sensor • Air flow meter

SIMPLE CHECK METHOD (For Europe)

EXHAUST GAS RECIRCULATION	
(EGR) SYSTEM	5-2
AIR SUCTION (AS) SYSTEM	5-3
IGNITION TIMING	5-4
OXYGEN SENSOR CHECK	5-5
IDLE CO/HC CONCENTRATION CHECK	5-6

EXHAUST GAS RECIRCULATION (EGR) SYSTEM

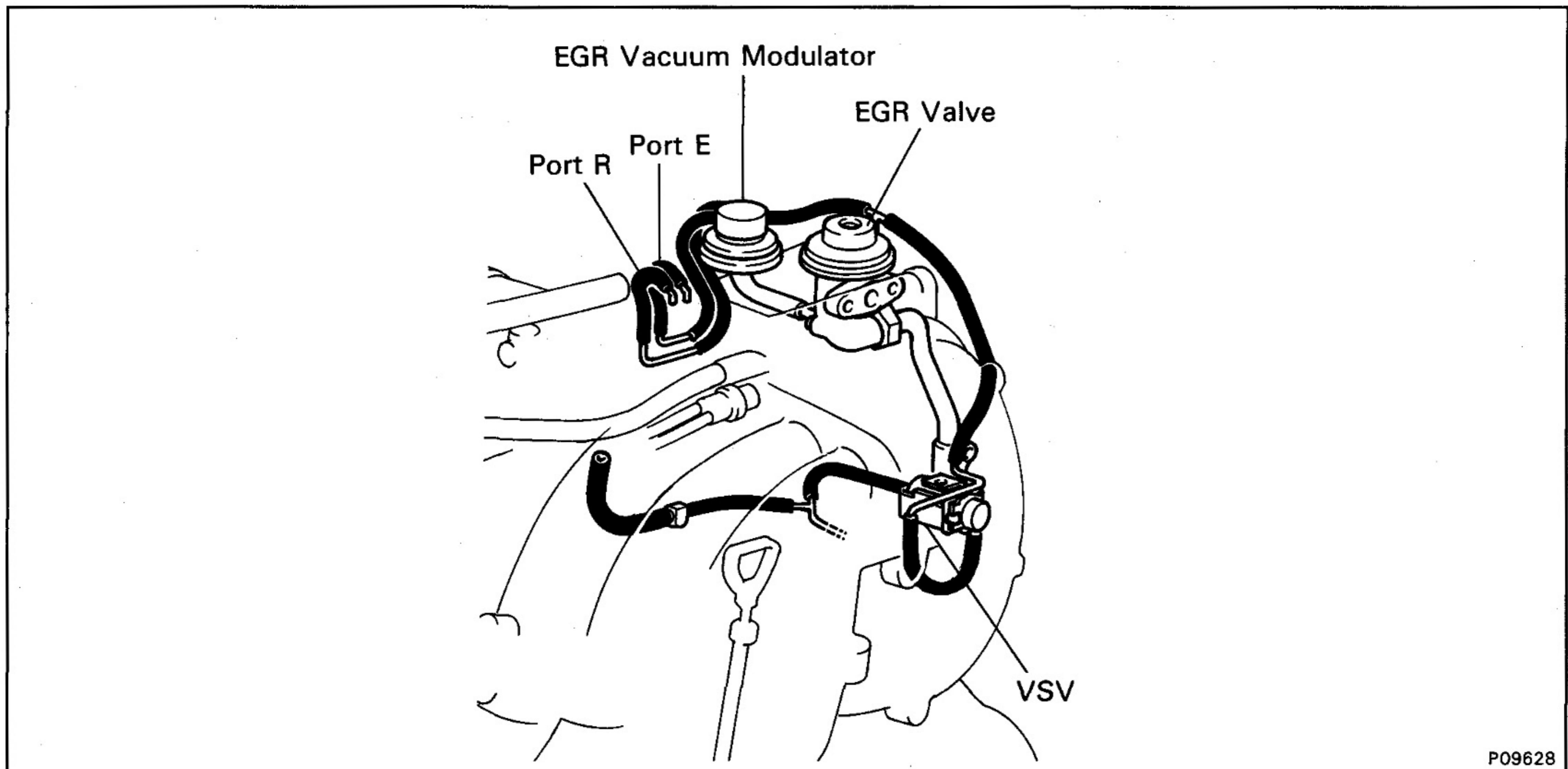

INSPECTION OF EGR SYSTEM

- (a) Warm up the engine.
- (b) Disconnect the vacuum hose from the Port E (EGR port) of the throttle body, and plug the Port E (EGR port).
- (c) While keeping the engine speed at 2,500 rpm, connect the vacuum hose to Port E (EGR port) of the throttle body.

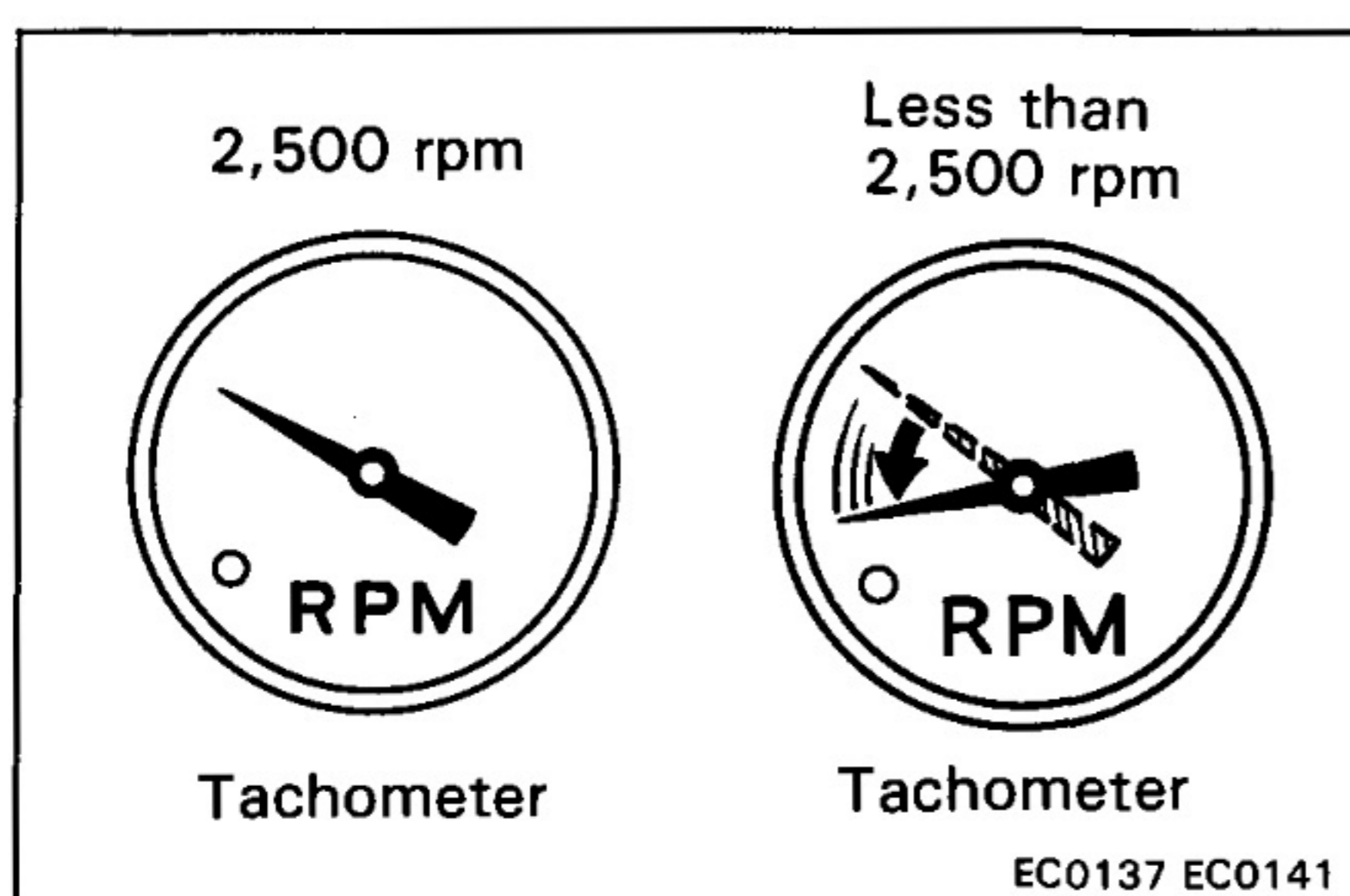

- (d) Confirm the engine speed decreasing from 2,500 rpm by the exhaust gas flowing in.

If the engine speed was not decreased, check the each parts of EGR system.

AIR SUCTION (AS) SYSTEM

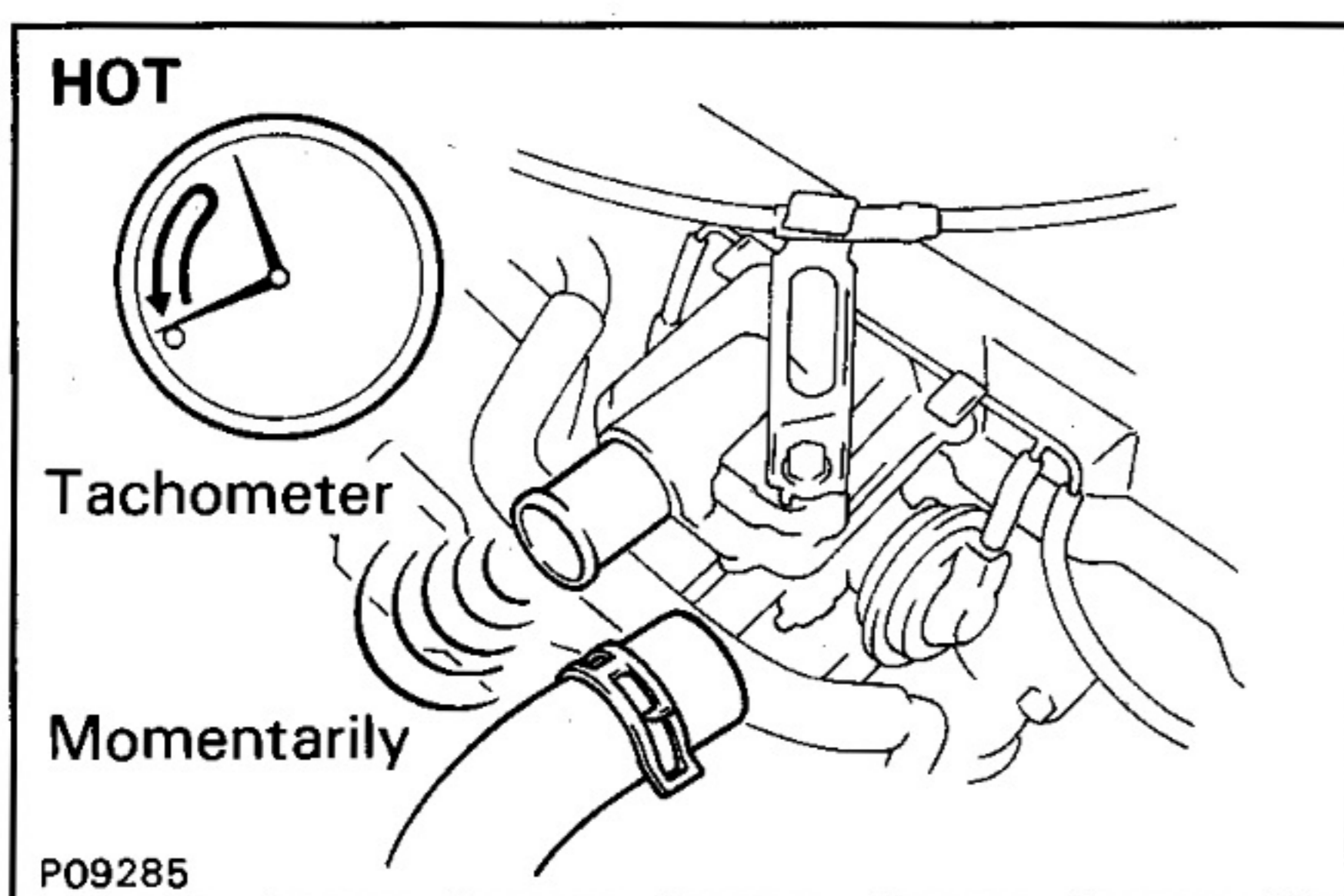
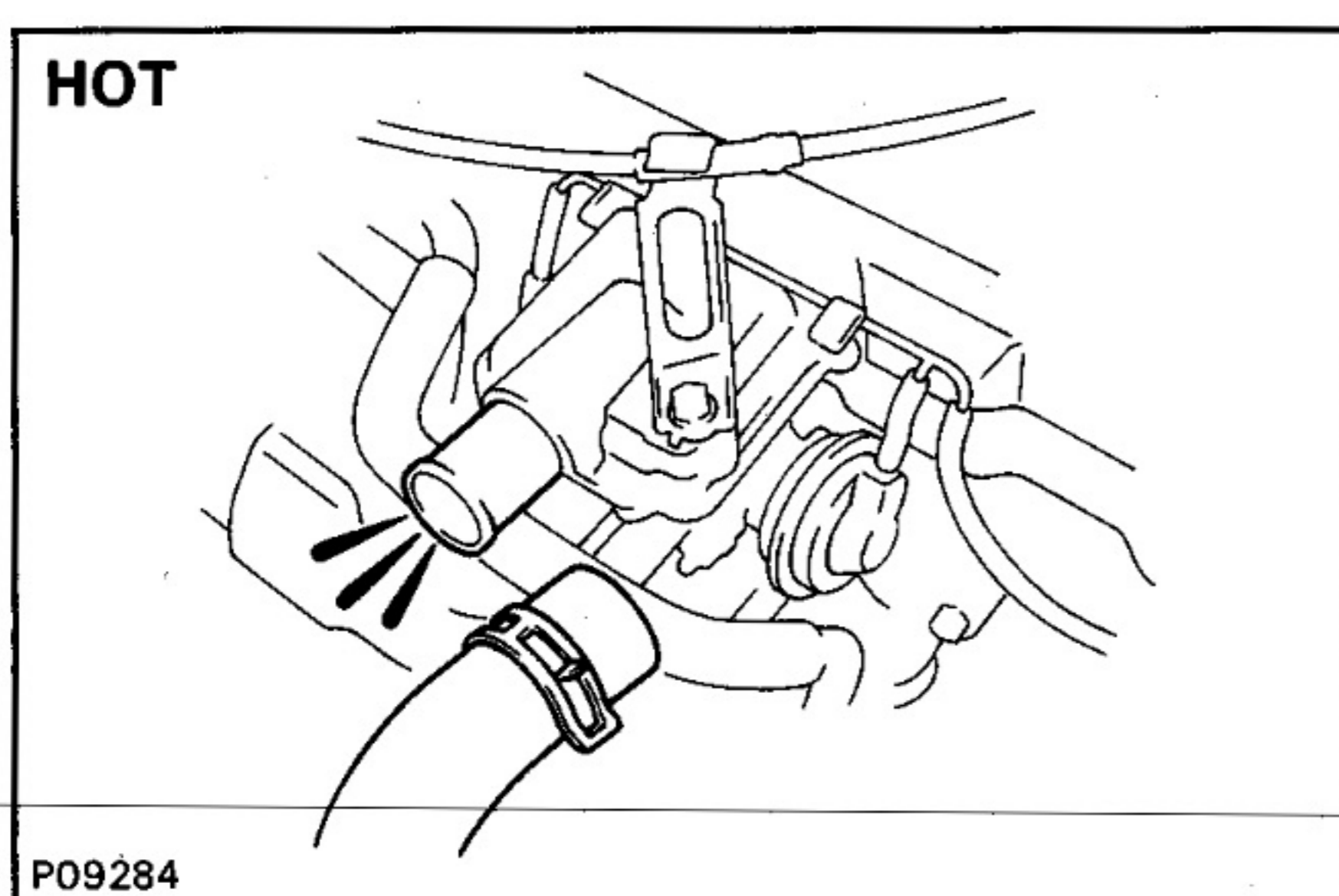
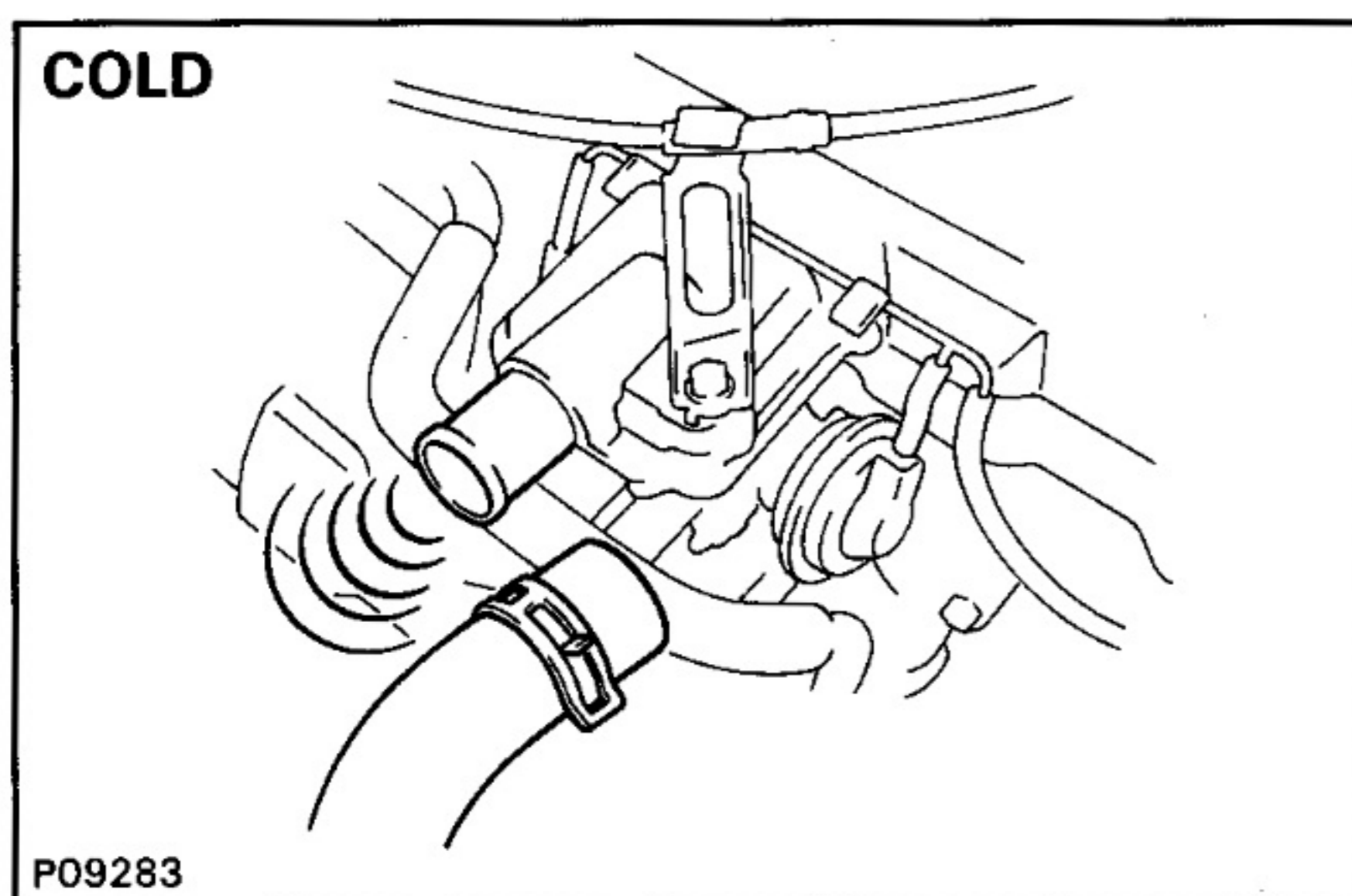
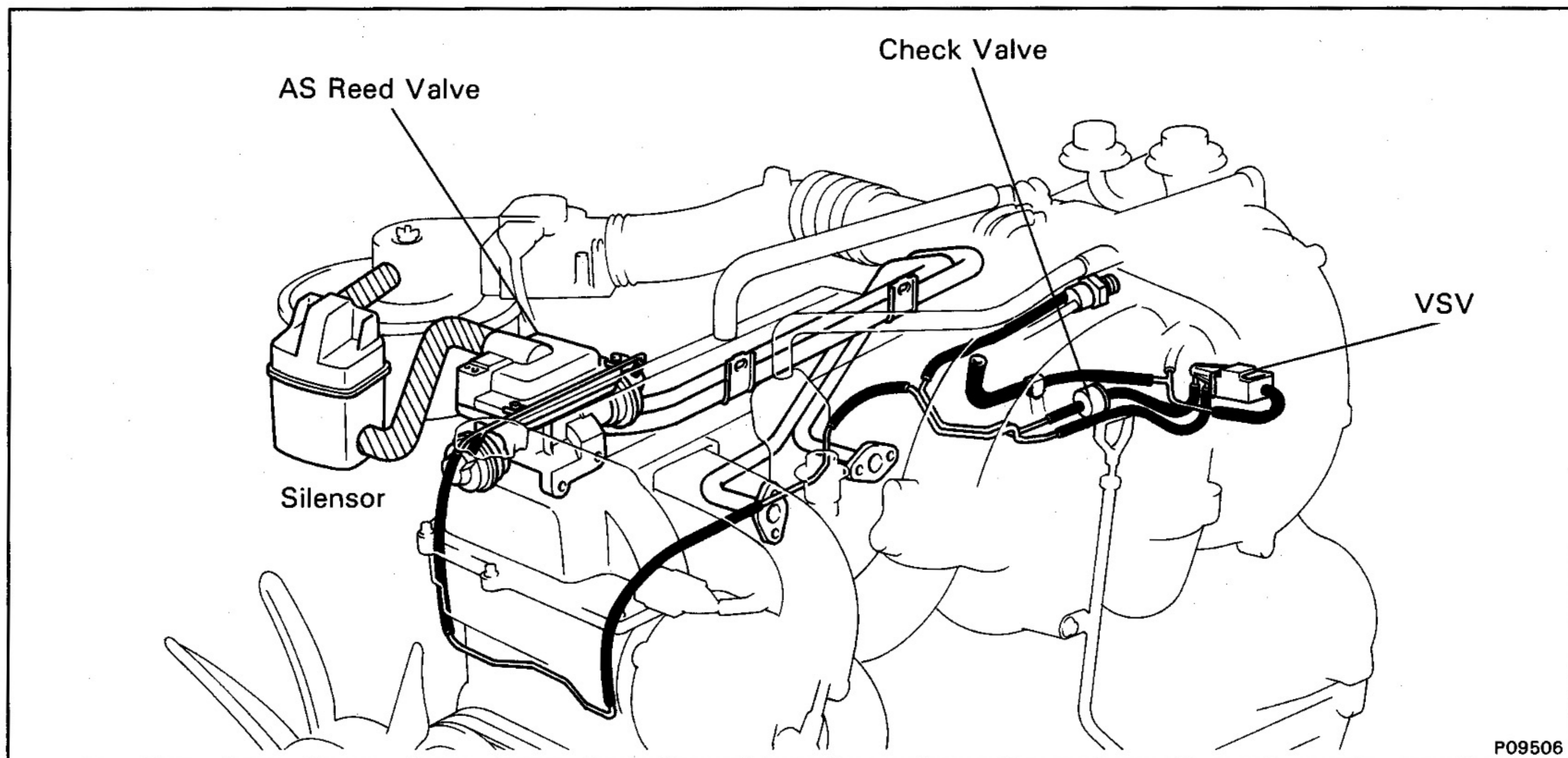

INSPECTION OF AS SYSTEM

1. INSPECT AS SYSTEM OPERATION WITH COLD ENGINE

- (a) The engine coolant temperature should be below 35°C (95°F).
- (b) Disconnect the No.2 air hose from the AS reed valve.
- (c) Start the engine.
- (d) Check that a bubbling noise is heard from the reed valve.

2. INSPECT AS SYSTEM OPERATION WITH HOT ENGINE

- (a) Warm up the engine.
- (b) With the engine idling, check that a bubbling noise is not heard from the AS reed valve.

- (c) Race the engine about 2,500 rpm and quickly close the throttle valve.

- (d) Check that a bubbling noise stops momentarily.

If you detect a problem when doing the above inspection, inspect each part.

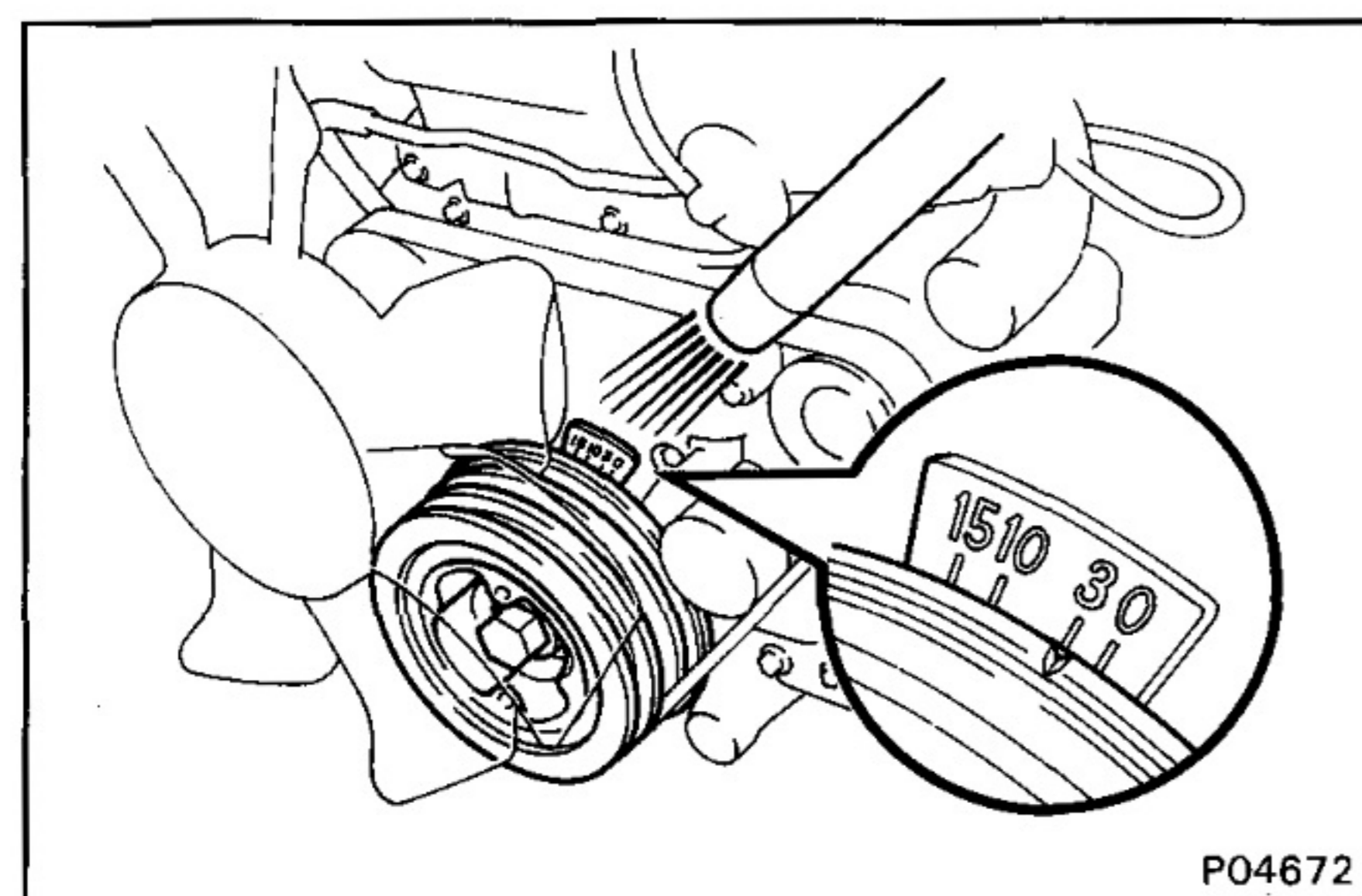
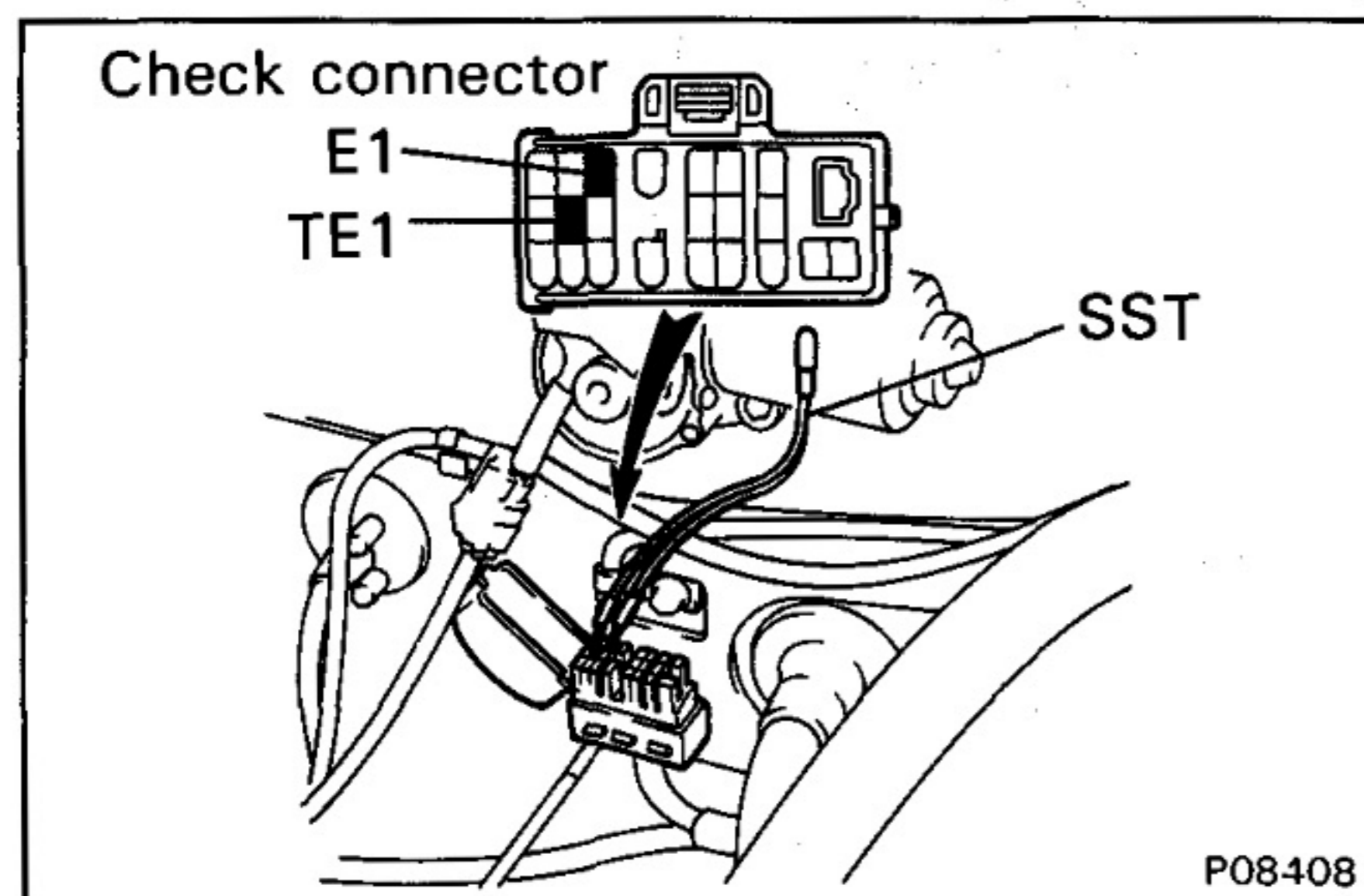
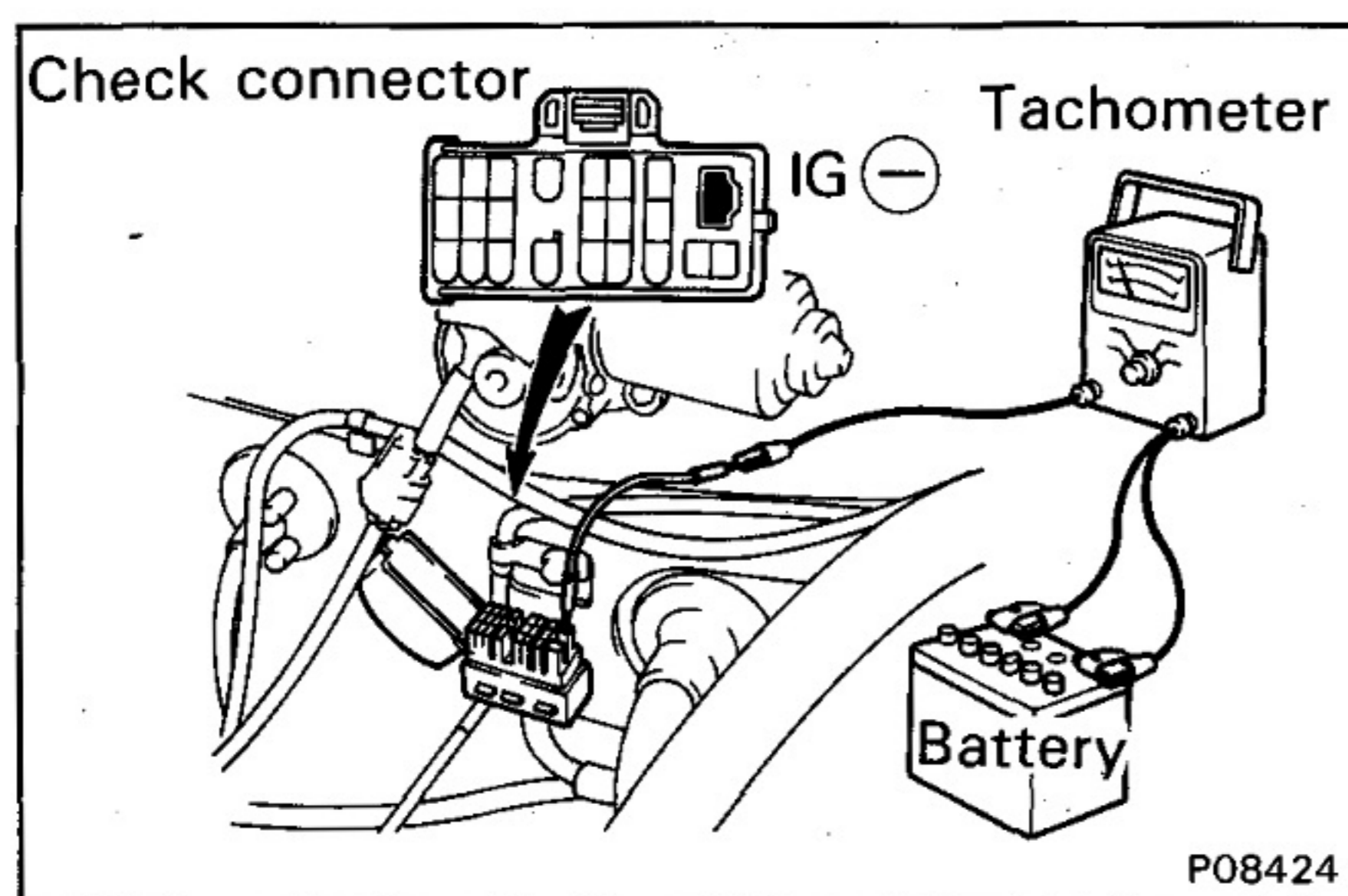

IGNITION TIMING

INSPECTION OF IGNITION TIMING

1. WARM ENGINE UP

Allow the engine to reach normal operating temperature.

2. CONNECT TACHOMETER AND TIMING LIGHT TO ENGINE

- (a) Connect the tachometer test probe to terminal IG ⊖ of the check connector.

NOTICE:

- **NEVER** allow the tachometer terminals to touch ground as it could result in damage to the igniter and/or ignition coil.
- As some tachometers are not compatible with this ignition system, we recommend that you confirm the compatibility of your unit before using.

- (b) Using SST, connect terminals TE1 and E1 of the check connector.

SST 09843-18020

3. INSPECT IGNITION TIMING

- (a) With the engine idling as specified, use a timing light to check the timing.

Ignition timing:

$3^{\circ} \pm 2^{\circ}$ BTDC@ idle.

(w/ Terminals TE1 and E1 connected).

- (b) Disconnect SST, and check the timing.

SST 09843-18020

Ignition timing:

$2^{\circ} - 13^{\circ}$ BTDC@ idle.

- (c) Race the engine and check the timing advance the ignition timing.

If the ignition timing is incorrect, adjust the ignition timing. (See page 4-2).

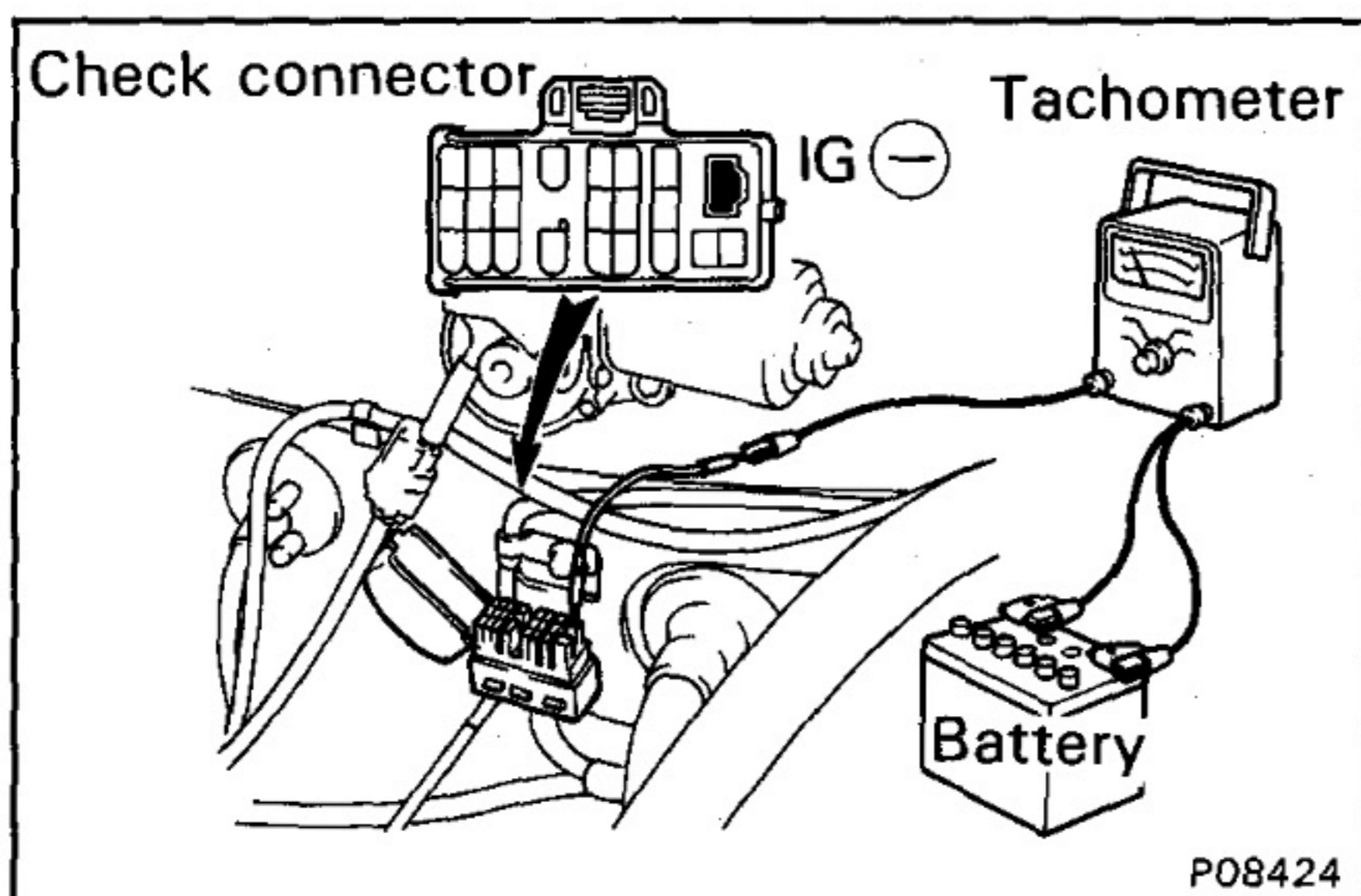

OXYGEN SENSOR CHECK

1. INITIAL CONDITIONS (See step 1 on page 5-6)

2. CONNECT TACHOMETER

3. CHECK OXYGEN SENSOR OPERATION

(a) Disconnect the vacuum hose from the charcoal canister and plug the hose end.

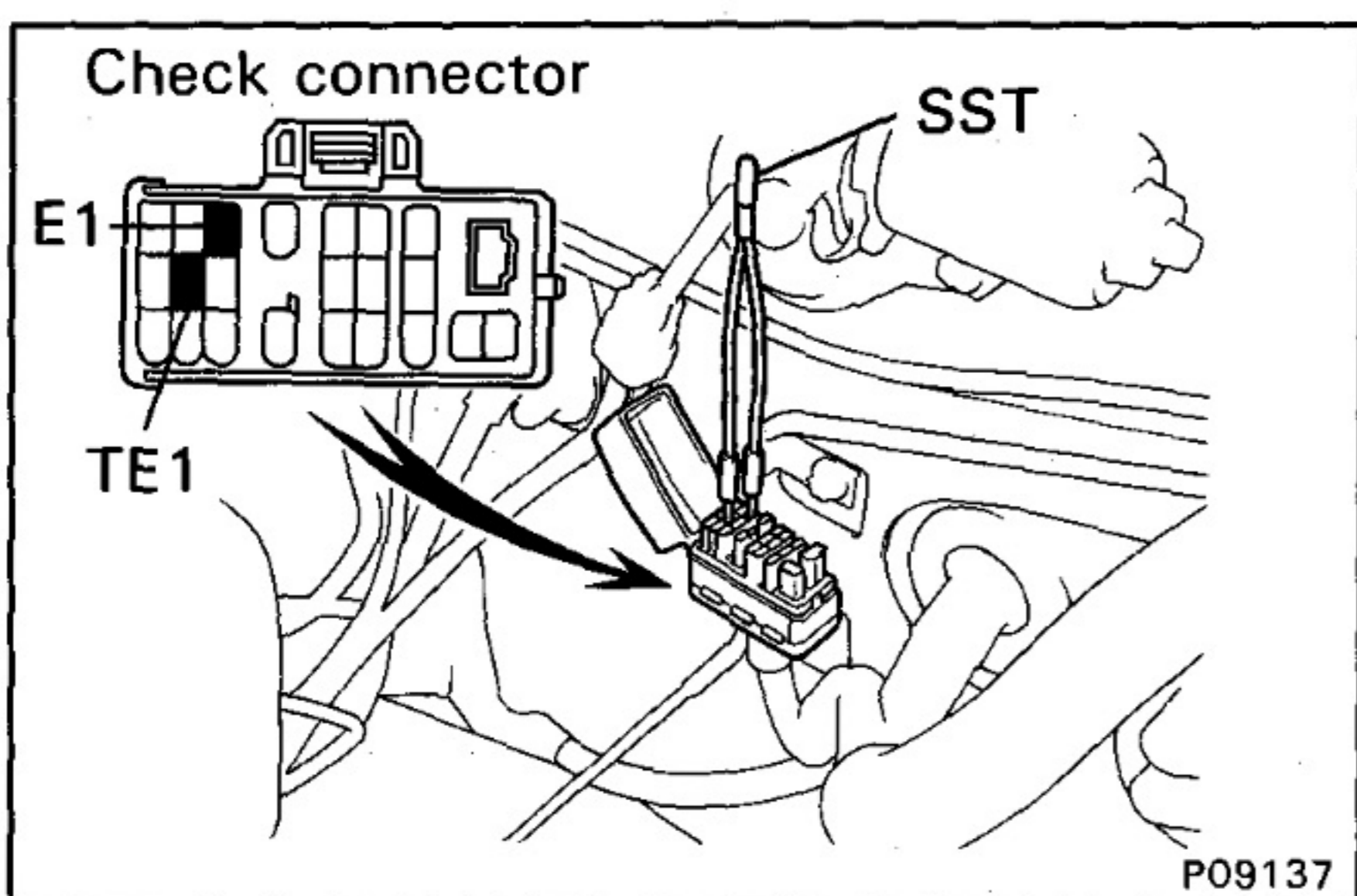

(b) Using SST, connect the terminals TE1 and E1 of the check connector.

SST 09843-18020

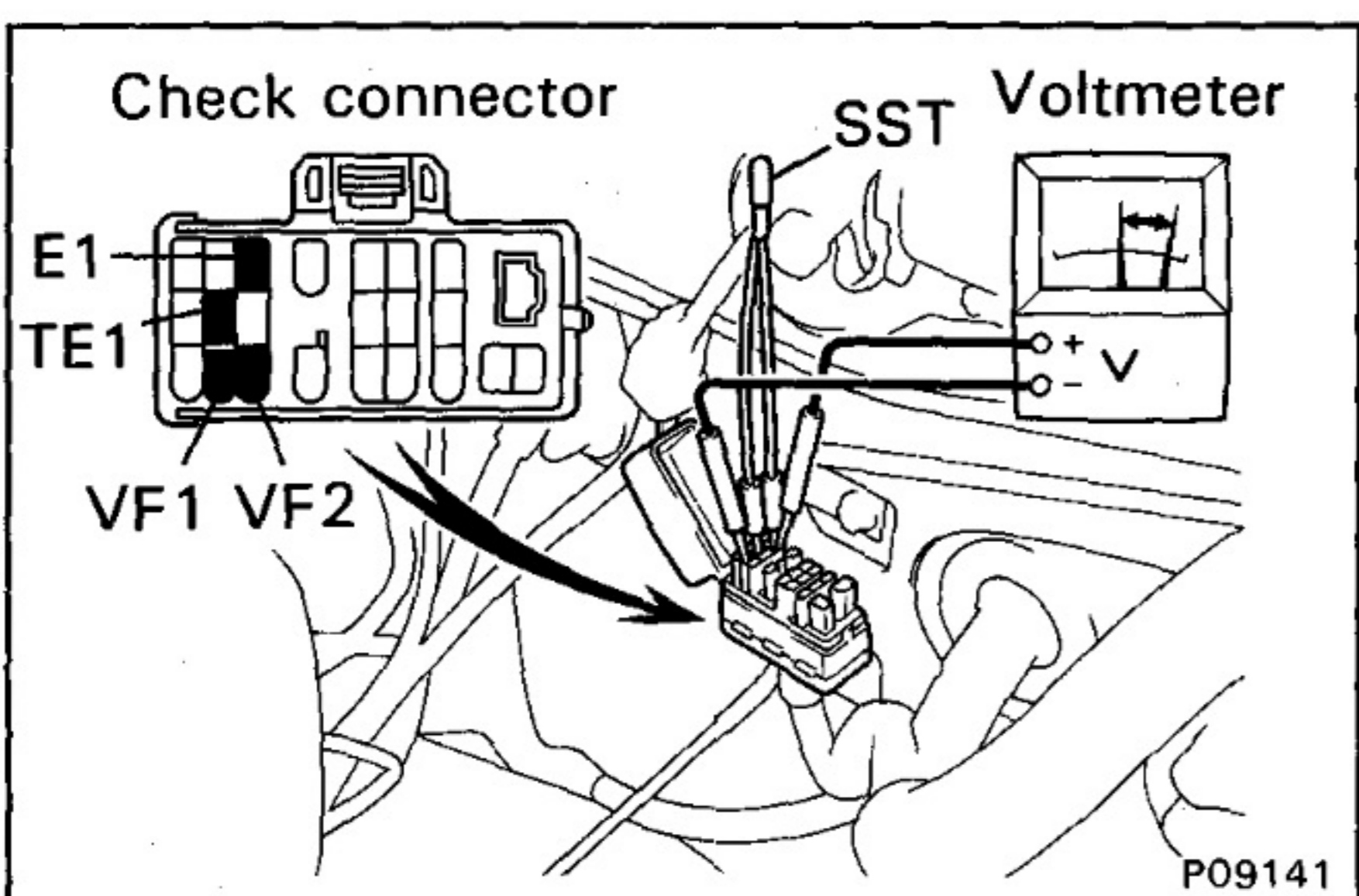

(c) Connect the positive (+) tester probe of a voltmeter to terminal VF1 (VF2) of the check connector, and negative (-) tester probe to terminal E1.

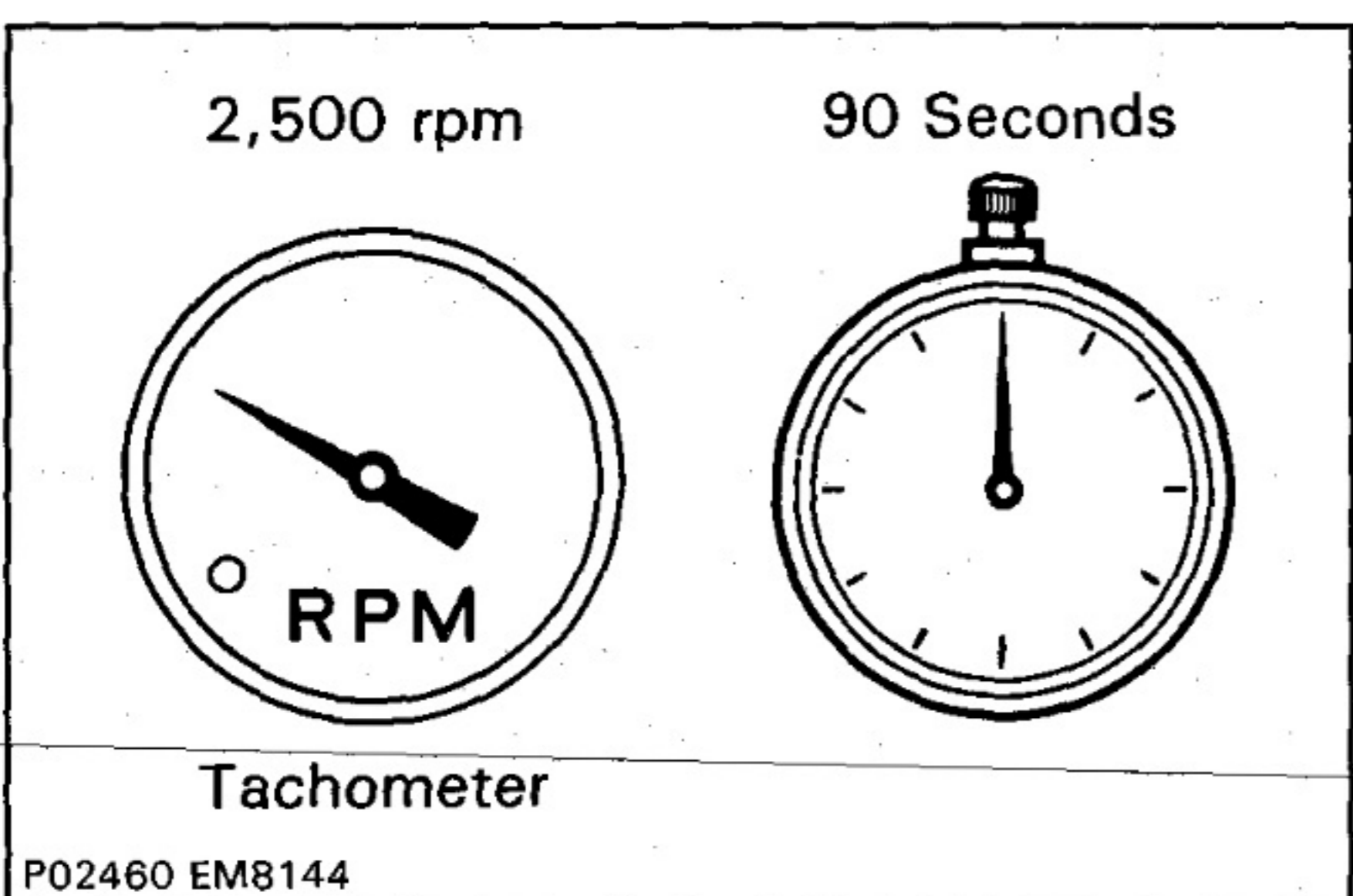

(d) Hold the engine speed at 2,500 rpm for 90 seconds.

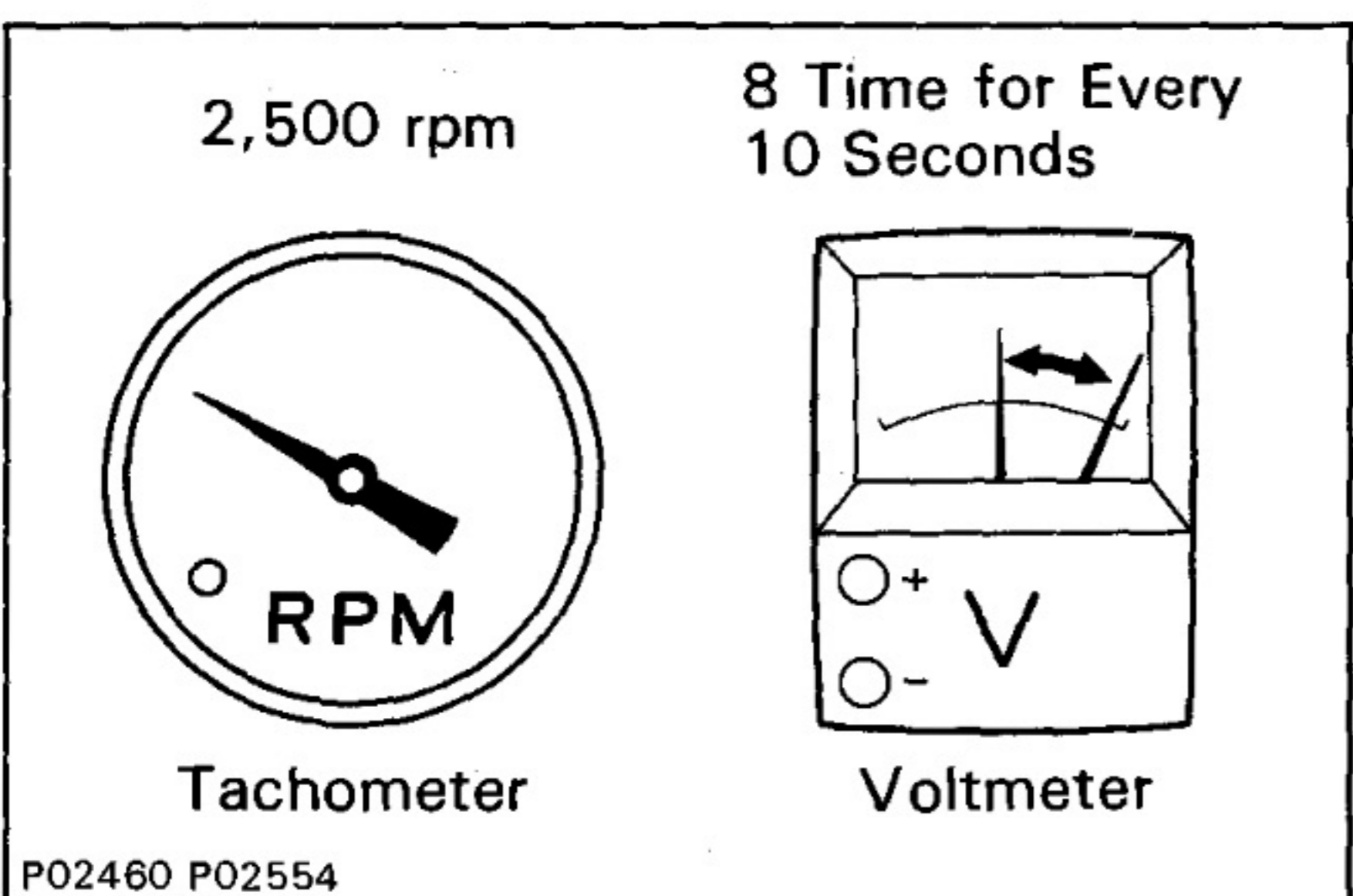

(e) Then, maintaining engine at 2,500 rpm, count how many times needle of voltmeter fluctuates between 0 and 5 V.

Minimum needle fluctuation:

8 times for every 10 seconds

If the fluctuation is less than minimum, check the air induction system. If necessary, see EFI SYSTEM.

IDLE CO/HC CONCENTRATION CHECK

HINT: This check is used only to determine whether or not the idle CO/HC complies with regulations.

1. INITIAL CONDITIONS

- (a) Engine at normal operating temperature
- (b) Air cleaner installed
- (c) All pipes and hoses of air induction system connected
- (d) All accessories switched OFF
- (e) All vacuum lines properly connected

HINT: All vacuum hoses for EGR systems, etc. should be properly connected.

- (f) SFI system wiring connectors fully plugged
- (g) Ignition timing set correctly
- (h) Transmission in neutral position
- (i) Tachometer and CO/HC meter calibrated by hand

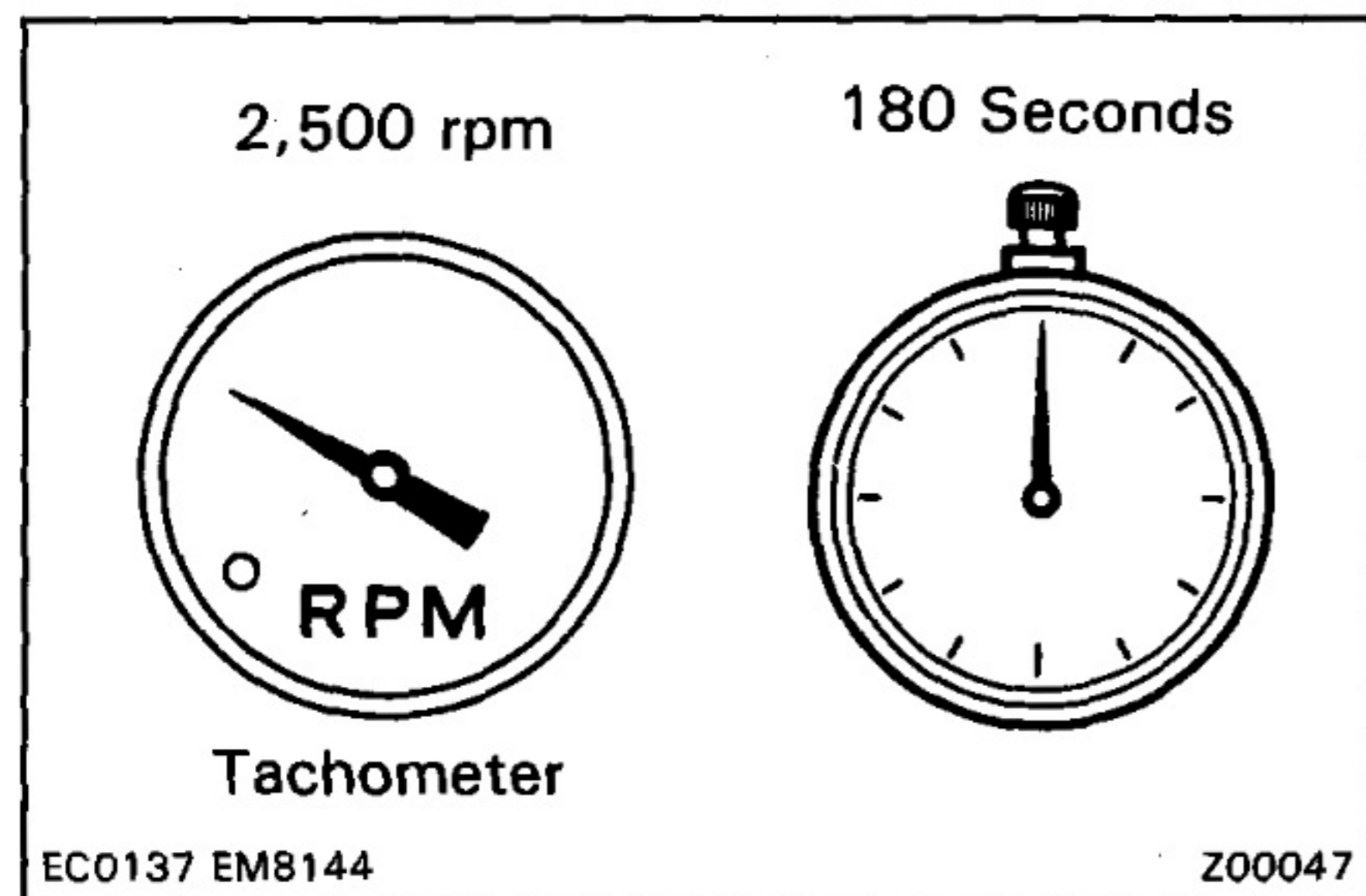

2. START ENGINE

3. RACE ENGINE AT 2,500 RPM FOR APPROX. 180 SECONDS

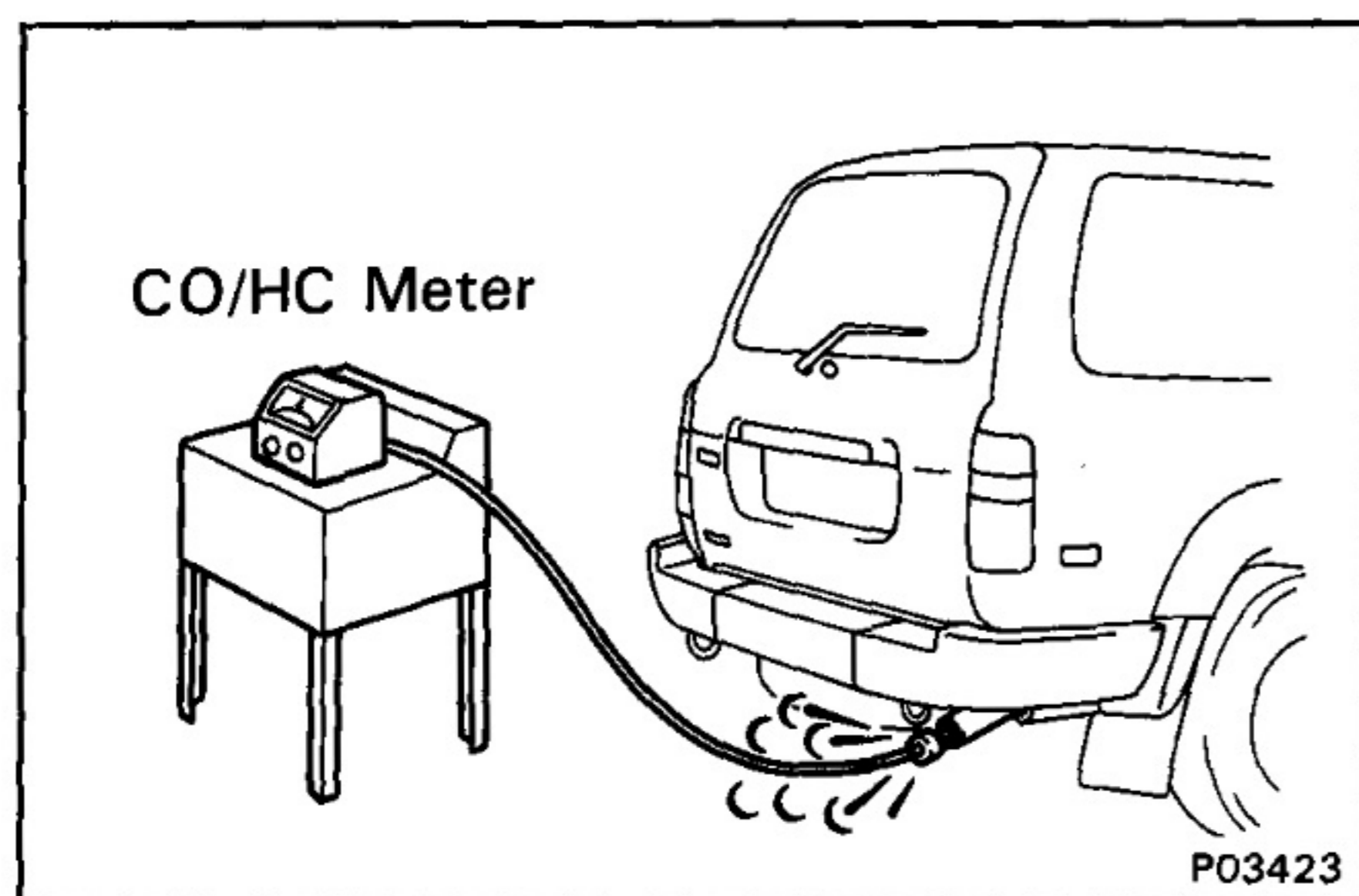

4. INSERT CO/HC METER TESTING PROBE INTO TAILPIPE AT LEAST 40 cm (1.3 ft) DURING IDLING

5. IMMEDIATELY CHECK CO/HC CONCENTRATION AT IDLE

HINT:

- When performing the test, follow the measurement order prescribed by the applicable local regulations.
- If the measurement order is against the regulations, perform troubleshooting. (See page 4-6).

SPECIFICATIONS

ENGINE TUNE-UP DATA A-2

ENGINE TUNE-UP DATA

Drive belt				
Deflection (Alternator) w/ 98 N (10 kgf, 22.0 lbf)				
New belt			11 — 15 mm	0.43 — 0.59 in.
Used belt			15 — 20 mm	0.59 — 0.79 in.
Tension (Alternator) (Reference) w/ SST 09216-00020				
New belt			33 — 57 kgf	
Used belt			15 — 35 kgf	
Battery specific gravity				
When fully charged at 20°C (68°F)			1.25 — 1.27	
Coolant capacity	w/ Front + Rear Heater		14.2 liters	15.0 US qts 12.4 Imp. qts
	w/ Front Heater		13.2 liters	14.0 US qts 11.6 Imp. qts
	w/o Heater		12.2 liters	12.9 US qts 10.7 Imp. qts
Engine oil API grade			SG or better	
Engine oil capacity	Dry fill		8.0 liters	8.5 US qts 7.0 Imp. qts
	Drain and refill			
	w/ Oil filter change		7.4 liters	7.8 US qts 6.5 Imp. qts
	w/o Oil filter change		6.9 liters	7.3 US qts 6.1 Imp. qts
High tension cord	Resistance	Limit	Less than 25 kΩ per cord	
Spark plug				
Type		ND	K16R-U	
		NGK	BKR5EYA	
Gap			0.8 mm	0.031 in.
Ignition timing			3° ± 2° BTDC@ idle. (w/ Terminal TE1 and E1 connected)	
Firing order			1-5-3-6-2-4	
Valve clearance (Cold)		Intake	0.15 — 0.25 mm	0.006 — 0.010 in.
		Exhaust	0.25 — 0.35 mm	0.010 — 0.014 in.
Idle speed			650 ± 50 rpm (A/C off, N range)	
Compression pressure at 250 rpm		STD	1,176 kPa	12.0 kgf/cm ² 171 psi
		Limit	883 kPa	9.0 kgf/cm ² 128 psi
Differential of pressure between each cylinder			98 kPa (1.0 kgf/cm ² , 14 psi) or less	

HINT:

- "New belt" refers to a belt which has been used less than 5 minutes on a running engine.
- "Used belt" refers to a belt which has been used on a running engine for 5 minutes or more.
- After installing the drive belt, check that it fits properly in the ribbed grooves.