

# TOYOTA

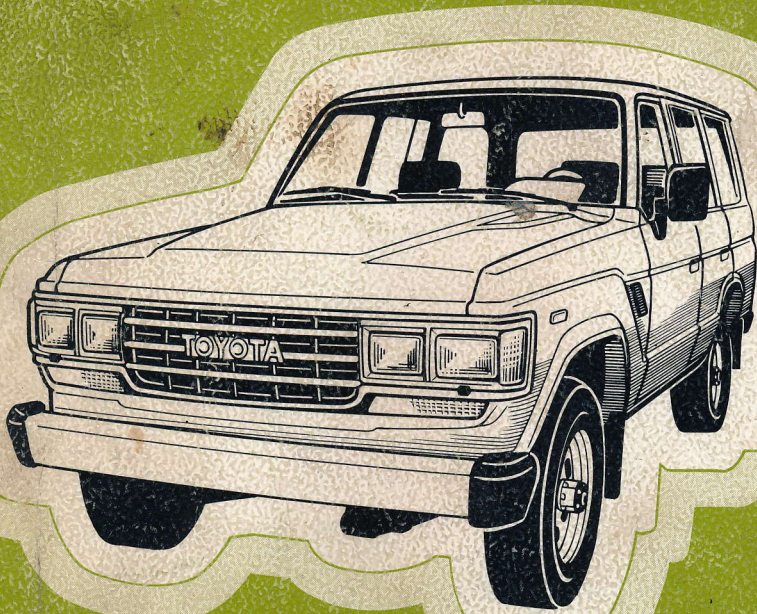

## Land Cruiser

# 1988 Repair Manual

- **Engine**
- **Chassis**
- **Body**
- **Electrical**
- **Specifications**

[Cruisercult.com](http://Cruisercult.com)

## FOREWORD

This manual contains maintenance and repair procedures for the 1988 LAND CRUISER.

Applicable model: FJ62 series

The manual is divided into 17 sections and 4 appendixes with a thumb index for each section at the edge of the pages.

For other service specifications and repair procedures of the 1988 Land Cruiser than those listed in this manual, refer to the following manuals;

Manual Name	Pub. No.
• Land Cruiser (Heavy-Duty) Chassis & Body Repair Manual	36262E
• A440F, A440L Automatic Transmission Repair Manual	36264E
• 1988 Model New Car Features	NCF024U

All information in this manual is based on the latest product information at the time of publication. However, specifications and procedures are subject to change without notice.

**TOYOTA MOTOR CORPORATION**



# 1988 TOYOTA LAND CRUISER REPAIR MANUAL

NOTE: The following screen toning letters sections refer to the LAND CRUISER (Heavy-Duty) REPAIR MANUAL FOR CHASSIS AND BODY (Pub. No. 36262E).

INTRODUCTION	<b>IN</b>
MAINTENANCE	<b>MA</b>
ENGINE MECHANICAL	<b>EM</b>
EMISSION CONTROL SYSTEMS	<b>EC</b>
EFI SYSTEM	<b>FI</b>
COOLING SYSTEM	<b>CO</b>
LUBRICATION SYSTEM	<b>LU</b>
IGNITION SYSTEM	<b>IG</b>
STARTING SYSTEM	<b>ST</b>
CHARGING SYSTEM	<b>CH</b>
AUTOMATIC TRANSMISSION	<b>AT</b>
TRANSFER	<b>TF</b>
PROPELLER SHAFT	<b>PR</b>
FRONT AXLE AND SUSPENSION	<b>FA</b>
REAR AXLE AND SUSPENSION	<b>RA</b>
BRAKE SYSTEM	<b>BR</b>
STEERING	<b>SR</b>
BODY ELECTRICAL SYSTEM	<b>BE</b>
BODY	<b>BO</b>
AIR CONDITIONING SYSTEM	<b>AC</b>
SERVICE SPECIFICATIONS	<b>A</b>
STANDARD BOLT TORQUE SPECIFICATIONS	<b>B</b>
SST AND SSM	<b>C</b>
ELECTRICAL WIRING DIAGRAMS	<b>D</b>



# INTRODUCTION

	Page
HOW TO USE THIS MANUAL .....	IN-2
IDENTIFICATION INFORMATION .....	IN-4
GENERAL REPAIR INSTRUCTIONS .....	IN-4
PRECAUTIONS FOR VEHICLES EQUIPPED WITH A CATALYTIC CONVERTER .....	IN-7
VEHICLE LIFT AND SUPPORT LOCATIONS .....	IN-8
ABBREVIATIONS USED IN THIS MANUAL .....	IN-10

**IN**

## HOW TO USE THIS MANUAL

To assist you in finding your way through the manual, the Section Title and major heading are given at the top of every page.

An **INDEX** is provided on the first page of each section to guide you to the item to be repaired.

At the beginning of each section, **PRECAUTIONS** are given that pertain to *all* repair operations contained in that section. *Read these precautions before starting any repair task.*

**TROUBLESHOOTING** tables are included for each system to help you diagnose the system problem and find the cause. The repair for each possible cause is referenced in the remedy column to quickly lead you to the solution.

## REPAIR PROCEDURES

Most repair operations begin with an overview illustration. It identifies the components and shows how the parts fit together.

Example:

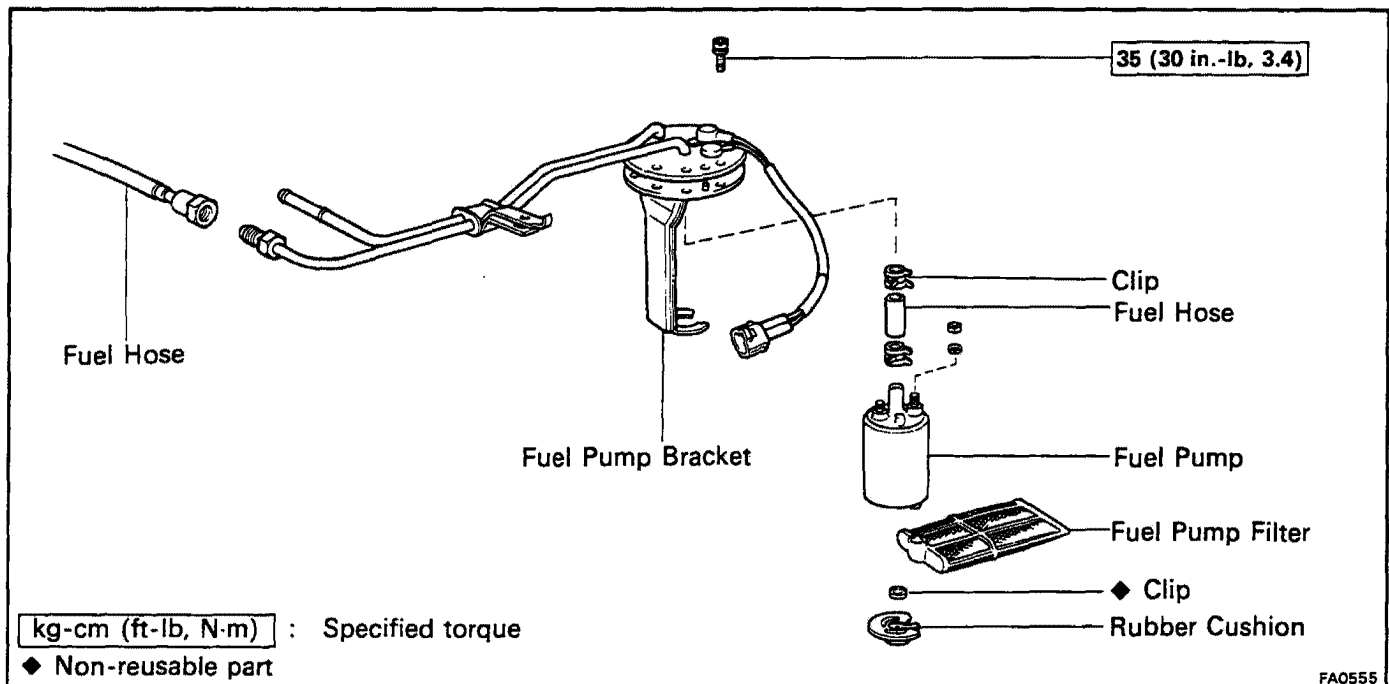

The procedures are presented in a step-by-step format:

- The illustration shows *what* to do and *where* to do it.
- The task heading tells *what* to do.
- The detailed text tells *how* to perform the task and gives other information such as specifications and warnings.

Example:

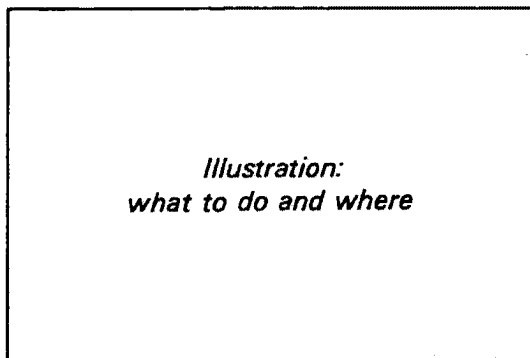

- Task heading: what to do*
- 21. CHECK PISTON STROKE OF OVERDRIVE BRAKE**
- (a) Place SST and a dial indicator onto the overdrive brake piston as shown in the figure.
- SST 09350-30020 (09350-06120)
- Set part No.*                      *Component part No.*
- Detail text: how to do it*
- (b) Measure the stroke applying and releasing the compressed air (4 – 8 kg/cm<sup>2</sup>, 57 – 114 psi or 392 – 785 kPa) as shown in the figure.
- Piston stroke: 1.40 – 1.70 mm (0.0551 – 0.0669 in.)**
- Specification*

This format provides the experienced technician with a FAST TRACK to the information needed. The upper case task heading can be read at a glance and only when necessary, the text below it provides detailed information. Important specifications and warnings always stand out in bold type.

## REFERENCES

References have been kept to a minimum. However, when they are required you are given the *page* to go to.

## SPECIFICATIONS

Specifications are presented in bold type throughout the text in the applicable step. You never have to leave the procedure to look up your specs. All specifications are also found in Appendix A, specifications, for quick reference.

## WARNINGS, CAUTIONS, NOTES:

- **WARNINGS** are presented in bold type, and indicate there is a possibility of injury to you or other people.
- **CAUTIONS** are also presented in bold type, and indicate the possibility of damage to the components being repaired.
- **NOTES** are separated from the text but do not appear in bold. They provide additional information to help you efficiently perform the repair.

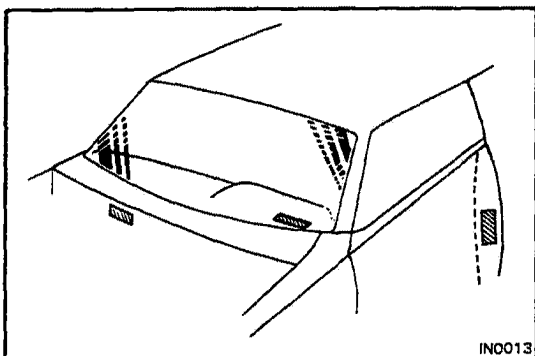

IN0013

## IDENTIFICATION INFORMATION

### VEHICLE IDENTIFICATION NUMBER

The vehicle identification number is stamped on the cowl panel of the engine compartment. This number is also stamped on top of the instrument panel and the driver's door post.

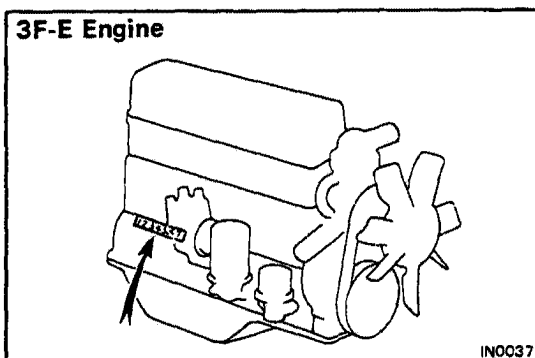

IN0037

### ENGINE SERIAL NUMBER

The engine serial number is stamped on the right side of the cylinder block.

## GENERAL REPAIR INSTRUCTIONS

1. Use, seat and floor covers to keep the vehicle clean and prevent damage.
2. During disassembly, keep parts in order to facilitate reassembly.
3. Observe the following:
  - (a) Before performing electrical work, disconnect the negative cable from the battery terminal.
  - (b) If it is necessary to disconnect the battery for inspection or repair, always disconnect the cable from the negative (-) terminal which is grounded to the vehicle body.
  - (c) To prevent damage to the battery terminal post, loosen the terminal nut and raise the cable straight up without twisting it or prying it.
  - (d) Clean the battery terminal posts and cable terminals with a shop rag. Do not scrape them with a file or other abrasive object.
  - (e) Install the cable terminal to the battery post with the nut loose, and tighten the nut after installation. Do not use a hammer to tap the terminal onto the post.
  - (f) Be sure the cover for the positive (+) terminal is properly in place.
4. Check hose and wiring connectors to make sure that they are secure and correct.

**5. Non-reusable parts**

- (a) Always replace cotter pins, gaskets, O-rings and oil seals etc. with new ones.
- (b) Non-reusable parts are indicated in the component illustrations by the "◆" symbol.

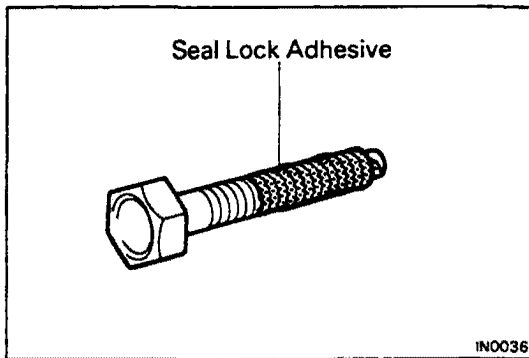
**6. Precoated parts**

Precoated parts are the bolts and nuts, which have been coated with a seal lock adhesive at the factory.

- (a) If a precoated part is tightened, loosened or caused to move in any way, it must be recoated with the specified adhesive.
- (b) Recoating of precoated parts
  - (1) Clean off the old adhesive from the bolt, nut or installation part threads.
  - (2) Dry with compressed air.
  - (3) Apply the specified seal lock adhesive to the bolt or nut threads.
- (c) Precoated parts are indicated in the component illustrations by the "★" symbol.

7. When necessary, use a sealer on gaskets to prevent leaks.
8. Carefully observe all specifications for bolt tightening torques. Always use a torque wrench.
9. Use of special service tools (SST) and special service materials (SSM) may be required, depending on the nature of the repair. Be sure to use SST and SSM where specified and follow the proper work procedure. A list of SST and SSM can be found at the back of this manual.
10. When replacing fuses, be sure the new fuse has the correct amperage rating. DO NOT exceed the fuse amp rating or use one of a lower rating.
11. Care must be taken when jacking up and supporting the vehicle. Be sure to lift and support the vehicle at the proper locations (See pages IN-8, 9).
  - (a) If the vehicle is to be jacked up only at the front or rear end, be sure to block the wheels in order to ensure safety.
  - (b) After the vehicle is jacked up, be sure to support it on stands. It is extremely dangerous to do any work on the vehicle raised on jack alone, even for a small job that can be finished quickly.

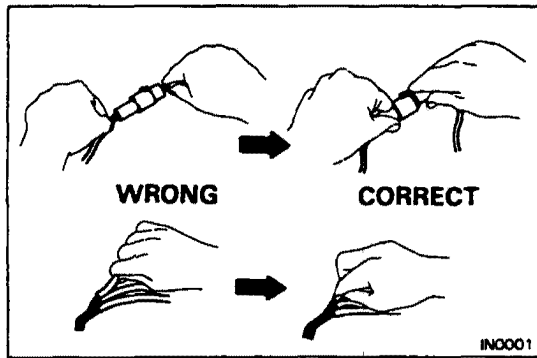

12. Observe the following precautions to avoid damage to the parts:

- (a) Do not open the cover or the case of the ECU unless absolutely necessary. (If the IC terminals are touched, the IC may be destroyed by static electricity.)
- (b) To disconnect vacuum hoses, pull on the end, not the middle of the hose.
- (c) To pull apart electrical connectors, pull on the connector itself, not the wires.
- (d) Be careful not to drop electrical components, such as sensors or relays. If they are dropped on a hard floor, they should be replaced and not reused.
- (e) When steam cleaning an engine, protect the IIA, from water.
- (f) Never use an impact wrench to remove or install thermo switches or thermo sensors.
- (g) When checking continuity at the wire connector, insert the tester probe carefully to prevent terminals from bending.
- (h) When using a vacuum gauge, never force the hose onto a connector that is too large. Use a step-down adapter instead. Once the hose has been stretched, it may leak.

13. Tag hoses before disconnecting them:

- (a) When disconnecting vacuum hoses, use tags to identify how they should be reconnected.
- (b) After completing a job, double check that the vacuum hoses are properly connected. A label on the floor pan shows the proper layout.

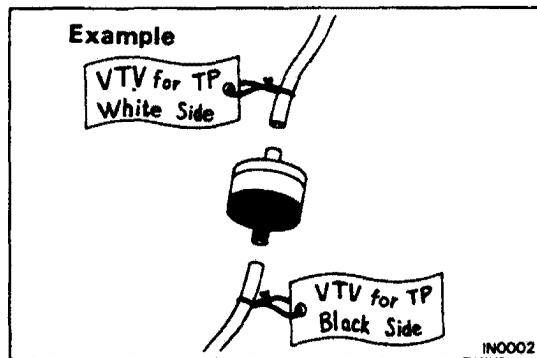

## PRECAUTIONS FOR VEHICLES EQUIPPED WITH A CATALYTIC CONVERTER

**WARNING:** If large amounts of unburned gasoline flow into the converter, it may overheat and create a fire hazard. To prevent this, observe the following precautions and explain them to your customer.

1. **Use only unleaded gasoline.**
2. **Avoid prolonged idling.**  
Avoid running the engine at idle speed for more than 20 minutes.
3. **Avoid spark jump test.**
  - (a) Spark jump test only when absolutely necessary. Perform this test as rapidly as possible.
  - (b) While testing, never race the engine.
4. **Avoid prolonged engine compression measurement.**  
Engine compression tests must be made as rapidly as possible.
5. **Do not run engine when fuel tank is nearly empty.**  
This may cause the engine to misfire and create an extra load on the converter.
6. **Avoid coasting with ignition turned off and prolonged braking.**
7. **Do not dispose of a used catalyst along with parts contaminated with gasoline or oil.**

# VEHICLE LIFT AND SUPPORT LOCATIONS

←  
Front

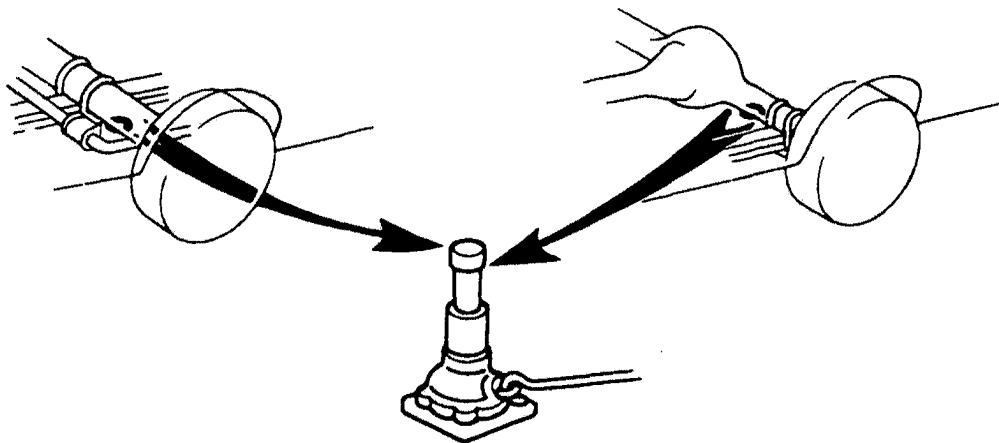
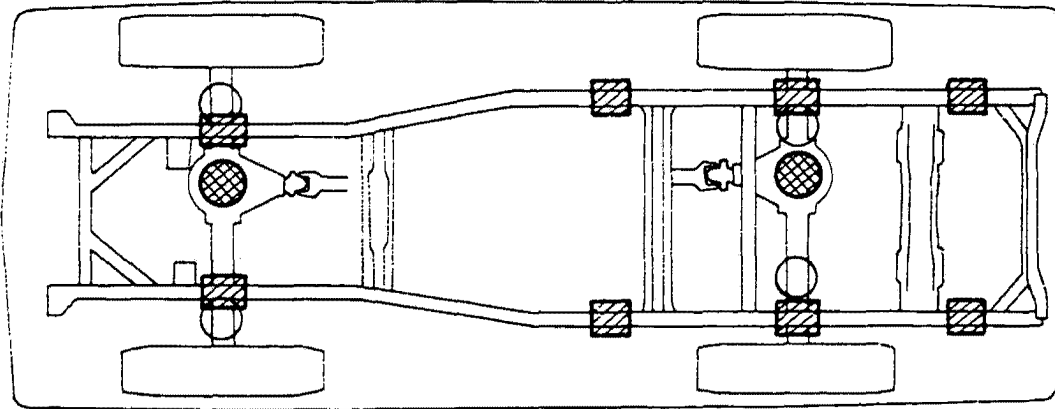

**JACK POSITION** \_\_\_\_\_ ●  
Front ..... Under the front differential  
Rear ..... Under the rear differential

**SCREW TYPE JACK POSITION** \_\_\_\_\_ ○

**SUPPORT POSITION**  
Safety stand ..... ▨

## ABBREVIATIONS USED IN THIS MANUAL

A/C	Air Conditioner
AI	Air Injection
ALH	Automatic Locking Hub
ASV	Air Switching Valve
A/T, ATM	Automatic Transmission
ATF	Automatic Transmission Fluid
BTDC	Before Top Dead Center
BVSV	Bimetal Vacuum Switching Valve
DP	Dash Pot
ECU	Electronic Controlled Unit
EFI	Electronic Fuel Injection
EGR	Exhaust Gas Recirculation
ESA	Electronic Spark Advance
EVAP	Evaporative (Emission Control)
EX	Exhaust (manifold, valve)
Ex.	Except
FIPG	Formed in Place Gasket
IG	Ignition
IN	Intake (manifold, valve)
ISC	Idle Speed Control
Max.	Maximum
MP	Multipurpose
O/S	Oversize
PCV	Positive Crankcase Ventilation
PS	Power Steering
SSM	Special Service Materials
SST	Special Service Tools
STD	Standard
S/W	Switch
TDC	Top Dead Center
TWC	Three-way Catalyst
U/S	Undersize
VCV	Vacuum Control Valve
VSV	Vacuum Switching Valve
VTV	Vacuum Transmitting Valve
w/	With
w/o	Without



# MAINTENANCE

	<b>Page</b>
<b>MAINTENANCE SCHEDULE .....</b>	<b>MA-2</b>
<b>MAINTENANCE OPERATIONS .....</b>	<b>MA-4</b>
<b>GENERAL MAINTENANCE .....</b>	<b>MA-14</b>



## **GENERAL NOTES:**

- Every service item in the periodic maintenance list must be performed.
- Failure to do even one item can cause the engine to run poorly and increase exhaust emissions.

# MAINTENANCE SCHEDULE

Maintenance operations: A = Check and adjust if necessary;  
 R = Replace, change or lubricate;  
 I = Inspect and correct or replace if necessary

## NORMAL CONDITION SCHEDULE

System	Service interval (Odometer reading or months, whichever comes first)	Maintenance services beyond 60,000 miles (96,000 km) should be performed at the same intervals shown in each maintenance schedule.										See page (item No.)
		Miles x 1,000	10	15	20	30	40	45	50	60		
	Maintenance items	Km x 1,000	16	24	32	48	64	72	80	96		
		Months	12	18	24	36	48	54	60	72		
ENGINE	Valve clearance★			A		A		A		A	MA-6 (item 12)	
	Drive belts <sup>(1)</sup>					I				I	MA-4 (item 1)	
	Engine oil and oil filter★		R		R	R	R		R	R	MA-5 (item 5)	
	Engine coolant <sup>(2)</sup>									R	MA-5 (item 6)	
	Exhaust pipes and mountings					I				I	MA-6 (item 10)	
FUEL	Air Filter★					R				R	MA-5 (item 4)	
	Fuel lines and connections					I				I	MA-6 (item 9)	
	Fuel tank cap gasket									R	MA-6 (item 8)	
IGNITION	Spark plug★*					R				R	MA-4 (item 2)	
EVAP	Charcoal canister	California only								I	MA-5 (item 7)	
EXHAUST	Oxygen sensors*	Except California								R(5)	MA-6 (item 11)	
BRAKES	Brake lining and drums			I		I		I		I	MA-7 (item 13)	
	Brake pads and discs			I		I		I		I	MA-8 (item 15)	
	Brake line pipes and hoses			I		I		I		I	MA-7 (item 13)	
CHASSIS	Steering linkage			I		I		I		I	MA-8 (item 16)	
	Ball joints and dust covers			I		I		I		I	MA-8 (item 16)	
	Front wheel bearing and thrust bush grease					R				R	MA-10 (item 21)	
	Steering knuckle and chassis grease <sup>(3)</sup>			R		R		R		R	MA-11 (item 22)	
	Propeller shaft grease <sup>(3)</sup>			R		R		R		R	MA-11 (item 22)	
	Automatic transmission, transfer (4WD), differential and steering gear box oil <sup>(4)</sup>			I		I		I		I	MA-8 (item 17) MA-9 (item 19) MA-10 (item 20)	
	Bolts and nuts on chassis and body			I		I		I		I	MA-12 (item 23)	

Maintenance services indicated by a star (★) or asterisk (\*) are required under the terms of the Emission Control Systems Warranty (ECSW). See Owner's Guide or Warranty Booklet for complete warranty information.

★ For vehicle sold in California

\* For vehicle sold outside California

### NOTE:

- (1) After 60,000 miles (96,000 km) or 72 months, inspect every 10,000 miles (16,000 km) or 12 months.
- (2) After 60,000 miles (96,000 km) or 72 months, replace every 30,000 miles (48,000 km) or 36 months.
- (3) If the propeller shaft has been immersed in water, it should be re-greased within daily.
- (4) Inspect the steering gear box for oil leakage only.
- (5) Replace at 80,000 miles (128,000 km) only.

Follow the severe condition schedule if vehicle is operated mainly under one or more of the following severe conditions:

- Towing a trailer, using a camper or car top carrier.
- Repeat short trips less than 5 miles (8 km) and outside temperatures remain below freezing.
- Extensive idling and/or low speed driving for a long distance such as police, taxi or door-to-door delivery use.
- Operating on dusty, rough muddy or salt spread roads.

## SEVERE CONDITION SCHEDULE

System	Service interval (Odometer reading or months, whichever comes first)	Maintenance services beyond 60,000 miles (96,000 km) should be performed at the same intervals shown in each maintenance schedule.																	See page (item No.)
		Miles x 1,000	5	7.5	10	15	20	22.5	25	30	35	37.5	40	45	50	52.5	55	60	
		Km x 1,000	8	12	16	24	32	36	40	48	56	60	64	72	80	84	88	96	
		Months	6	9	12	18	24	27	30	36	42	45	48	54	60	63	66	72	
ENGINE	Valve clearance★				A				A				A				A	MA-6 (item 12)	
	Drive belts <sup>(1)</sup>								I								I	MA-4 (item 1)	
	Engine oil and oil filter★	R		R	R	R		R	R	R		R	R	R		R	R	MA-5 (item 5)	
	Engine coolant <sup>(2)</sup>																R	MA-5 (item 6)	
	Exhaust pipes and mountings				I				I				I				I	MA-6 (item 10)	
FUEL	Air Filter★ <sup>(3)</sup>	I		I	I	I		I	R	I		I	I	I		I	R	MA-5 (item 3, 4)	
	Fuel lines and connections								I								I	MA-6 (item 9)	
	Fuel tank cap gasket																R	MA-6 (item 8)	
IGNITION	Spark plug★★								R								R	MA-4 (item 2)	
EVAP	Charcoal canister	California only															I	MA-5 (item 7)	
EXHAUST	Oxygen sensors*	Except California															R(7)	MA-6 (item 11)	
BRAKES	Brake lining and drums		I		I		I		I		I		I		I		I	MA-7 (item 13)	
	Brake pads and discs		I		I		I		I		I		I		I		I	MA-8 (item 15)	
	Brake line pipes and hoses				I				I				I				I	MA-7 (item 13)	
CHASSIS	Steering linkage		I		I		I		I		I		I		I		I	MA-8 (item 16)	
	Ball joints and dust covers		I		I		I		I		I		I		I		I	MA-8 (item 16)	
	Automatic transmission, transfer, differential steering gear box oil <sup>(4)</sup>					R				R				R			R	MA-8 (item 17) MA-9 (item 19) MA-10 (item 20)	
	Front wheel bearing grease								R								R	MA-10 (item 21)	
	Steering knuckle and chassis grease <sup>(5)</sup>		R		R		R		R		R		R		R		R	MA-11 (item 22)	
	Propeller shaft grease <sup>(5)</sup>		R		R		R		R		R		R		R		R	MA-11 (item 22)	
	Bolts and nuts on chassis and body <sup>(6)</sup>		I		I		I		I		I		I		I		I	MA-12 (item 23)	

Maintenance services indicated by a star (★) or asterisk (\*) are required under the terms of the Emission Control Systems Warranty (ECSW). See Owner's Guide or Warranty Booklet for complete warranty information.

- ★ For vehicle sold in California
- \* For vehicle sold outside California

**NOTE:**

- (1) After 60,000 miles (96,000 km) or 72 months, inspect every 10,000 miles (16,000 km) or 12 months.
- (2) After 60,000 miles (96,000 km) or 72 months, replace every 30,000 miles (48,000 km) or 36 months.
- (3) Applicable when operating mainly on dusty roads. If not, follow the normal condition schedule.
- (4) Inspect the steering gear box for oil leakage only.
- (5) If the propeller shaft has been immersed in water, it should be re-greased within daily.
- (6) Applicable when operating mainly on rough and/or muddy roads. If not, follow the normal condition schedule.
- (7) Replace at 80,000 miles (128,000 km) only.

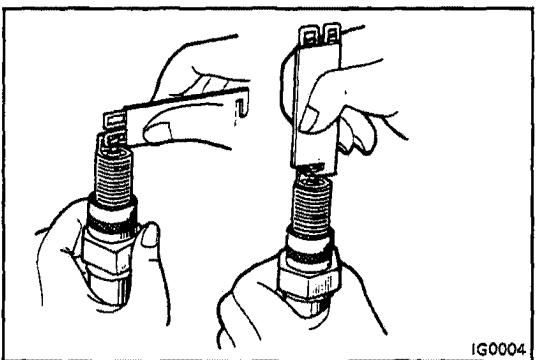
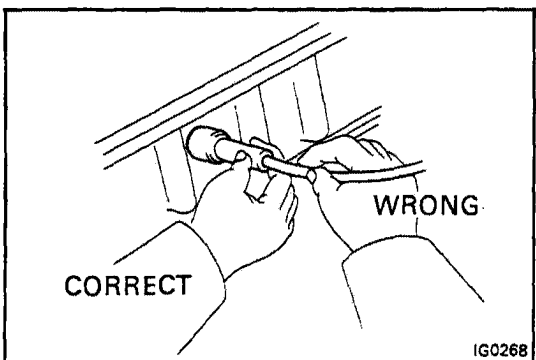
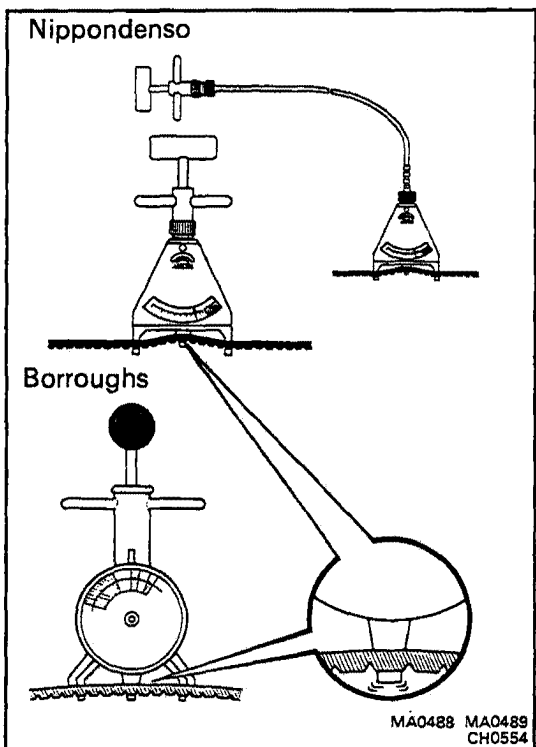
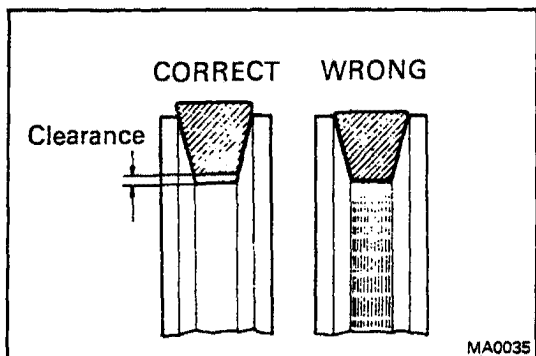

# MAINTENANCE OPERATIONS

## ENGINE

### Cold Engine Operations

#### 1. INSPECT DRIVE BELTS

- (a) Visually check the belt for cracks, oiliness or wear. Check that the belt does not touch the bottom of the pulley groove.

If necessary, replace the drive belt.

- (b) Using a belt tension gauge, check the drive belt tension.

Belt tension gauge:

Nippondenso BTG-20 (95506-00020) or  
Borroughs No. BT-33-73F

Drive belt tension:

Alternator	Used belt	100 ± 20 lb
	New belt	145 ± 25 lb
PS Pump (Air Pump)	Used belt	100 ± 20 lb
	New belt	145 ± 25 lb
A/C	Used belt	80 ± 20 lb
	New belt	125 ± 25 lb

If necessary, adjust the drive belt tension.

NOTE:

- When checking the tension, be sure the gauge is on the belt protrusion. (ex. A/C drive belt).
- "New belt" refers to a belt which has been used less than 5 minutes on a running engine.
- "Used belt" refers to a belt which has been used on a running engine for 5 minutes or more.
- After replacing the drive belt, check that it fits properly in the ribbed grooves, especially in the places difficult to see.
- After installing a new belt, run the engine for about 5 minutes and then recheck the tension.

#### 2. REPLACE SPARK PLUGS

- (a) Disconnect the high-tension cords of the spark plug at the boot. Do not pull on the cords.
- (b) Remove the spark plugs.

- (c) Set the gap on the new plugs.

Correct electrode gap: 0.8 mm (0.031 in.)  
Recommended spark plugs: ND W16EXR-U  
NGK BPR5EY

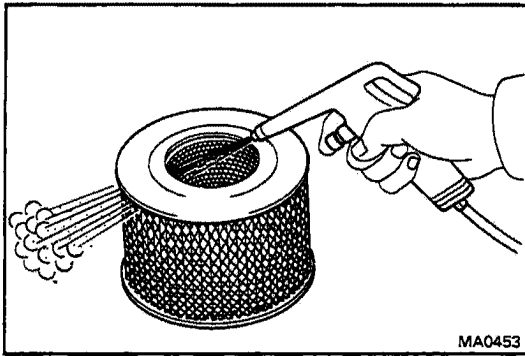

### 3. INSPECT AIR FILTER

- (a) Visually check that the air cleaner element is not excessively dirty, damaged or oily.

If necessary, replace the air cleaner element.

- (b) Clean the element with compressed air.

First blow from inside thoroughly, then blow off the outside of the element.

### 4. REPLACE AIR FILTER

Replace the used air cleaner element with a new one.

### 5. REPLACE ENGINE OIL AND OIL FILTER (See page LU-4)

Oil grade: API grade SF or SF/CC, multigrade, fuel-efficient and recommended viscosity oil.

Engine oil capacity:

Drain and refill

w/o Oil filter change

7.0 liters (7.4 US qts, 6.2 Imp. qts)

w/ Oil filter change

7.8 liters (8.2 US qts, 7.0 Imp. qts)

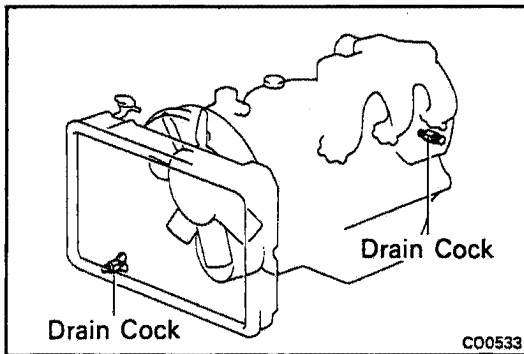

### 6. REPLACE ENGINE COOLANT

- (a) Drain the coolant from radiator and engine drain cocks.

- (b) Close the drain cocks.

- (c) Fill system with coolant.

Coolant capacity:

w/ Front heater

17.5 liters (18.5 US qts, 15.4 Imp. qts)

w/ Front and rear heaters

19.5 liters (20.6 US qts, 17.2 Imp. qts)

Use a good brand of ethylene-glycol base coolant, mixed according to the manufacturer's instructions.

### 7. CALIFORNIA VEHICLES ONLY: INSPECT CHARCOAL CANISTER

- (a) Disconnect the hoses to the charcoal canister. Label the hoses for correct installation.

- (b) Plug pipe A with your finger and blow compressed air (3 kg/cm<sup>2</sup>, 43 psi or 294 kPa) through pipe B (fuel tank side).

- Check that air comes out of the bottom pipe C without resistance.

- Check that no activated charcoal comes out.

If necessary, replace the charcoal canister.

NOTE: Do not attempt to wash the charcoal.

- (c) Connect the hoses to the charcoal canister.

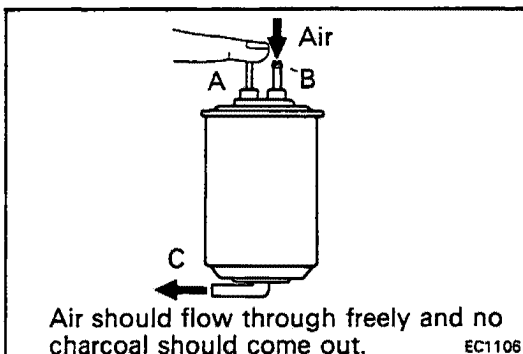

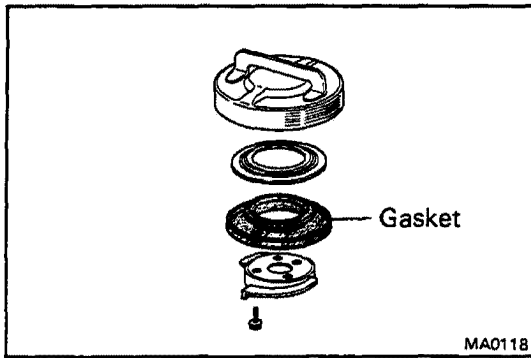

**8. REPLACE GASKET IN FUEL TANK CAP**

- (a) Remove the four screws, retainer and old gasket from the tank cap.
- (b) Install the new gasket and retainer with the four screws.
- (c) Inspect the cap for damage or cracks.

**9. INSPECT FUEL LINES AND CONNECTIONS**

Visually inspect the fuel lines for cracks, leakage, loose connections, deformation or tank band looseness.

**10. INSPECT EXHAUST PIPES AND MOUNTINGS**

Visually inspect the pipes, hangers, and connections for severe corrosion, leaks or damage.

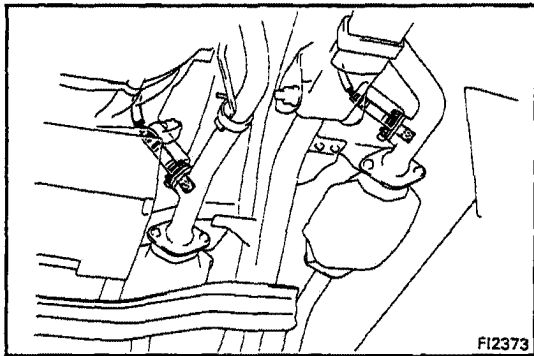

**11. EXCEPT CALIFORNIA VEHICLES: REPLACE OXYGEN SENSORS**

- (a) Disconnect the oxygen sensor connector.
- (b) Remove the two nuts, heat insulator, oxygen sensor and gasket from the exhaust manifold.
- (c) Install new gasket, oxygen sensor and heat insulator with the two nuts.

**Torque: 200 kg-cm (14 ft-lb, 20 N-m)**

- (d) Inspect the oxygen sensor operation. (See page FI-80)

**Hot Engine Operations**

**12. ADJUST VALVE CLEARANCE**

- (a) Warm up the engine to normal operating temperature.
- (b) Stop the engine and remove the cylinder head cover.
- (c) Set No.1 cylinder to TDC/compression.
  - Align the TDC mark of the drive plate with the timing pointer by turning the crankshaft clockwise with a wrench.
  - Check that the rocker arms on the No. 1 cylinder are loose and rocker arms on the No. 6 are tight.

If not, turn the crankshaft one revolution (360°) and align the mark as above.

- (d) Adjust the clearance of half of valves.

- Adjust only those valves indicated by arrows.

**Valve clearance (Hot):**

**Intake 0.20 mm (0.008 in.)**  
**Exhaust 0.35 mm (0.014 in.)**

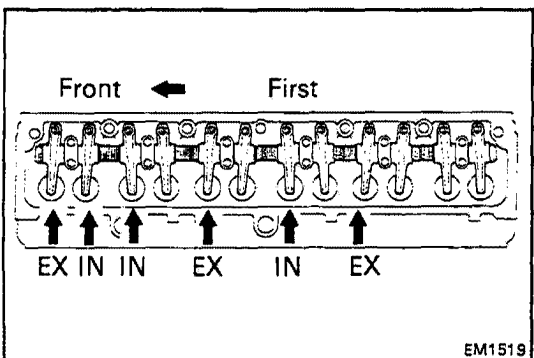
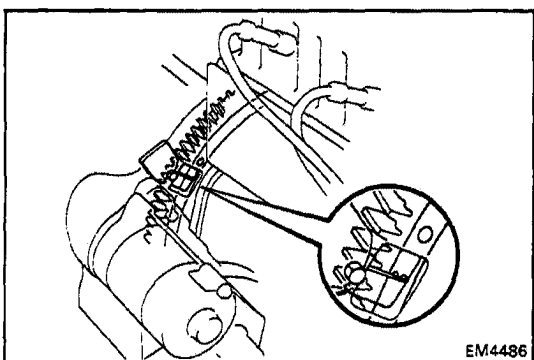

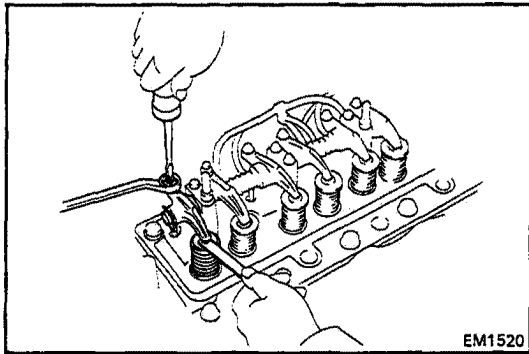

EM1520

- Using a thickness gauge, measure the valve clearance between the valve stem and rocker arm. Loosen the lock nut and turn the adjusting screw to set the proper clearance. Hold the adjusting screw in position and tighten the lock nut.
- Recheck the valve clearance. The thickness gauge should slide with a very slight drag.

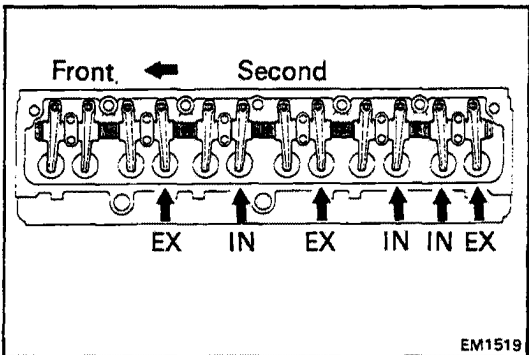

EM1519

- (e) Turn the crankshaft pulley one revolution (360°) and align the mark as above. Adjust only the valves indicated by arrows.
- (f) Reinstall the cylinder head cover.

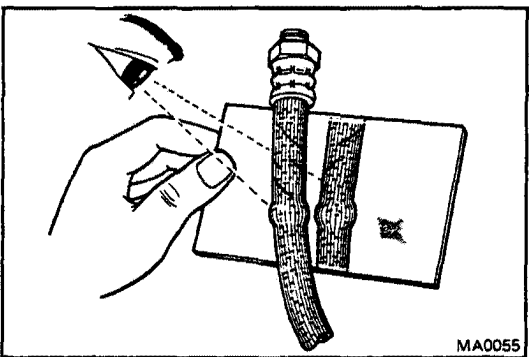

MA0055

## BRAKES

### 13. INSPECT BRAKE LINE PIPES AND HOSES

NOTE: Inspect in a well lighted area. Inspect the entire circumference and length of the brake hoses using a mirror as required. Turn the front wheels fully right or left before inspecting the front brake.

- (a) Check all brake lines and hoses for:
  - Damage
  - Wear
  - Deformation
  - Cracks
  - Corrosion
  - Leaks
  - Bends
  - Twists
- (b) Check all clamps for tightness and connections for leakage.
- (c) Check that the hoses and lines are clear of sharp edges, moving parts and the exhaust system.
- (d) Check that the lines installed in grommets pass through the center of the grommets.

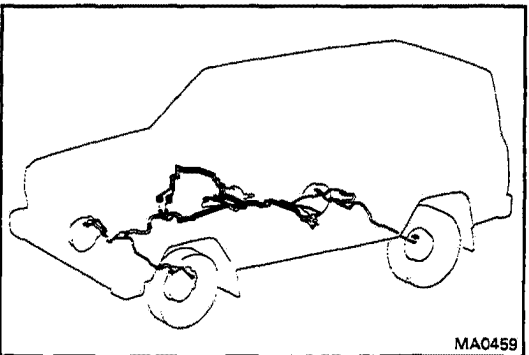

MA0459

### 14. INSPECT REAR BRAKE LININGS AND DRUMS

- (a) Check the lining-to drums contact condition and lining wear.

**Minimum lining thickness: 1.5 mm (0.059 in.)**

- (b) Check the brake drum for scoring or wear.

**Maximum drum inside diameter:**

**297.0 mm (11.693 in.)**

- (c) Clean the brake parts with a damp cloth.

NOTE: Do not use compressed air to clean the brake parts.

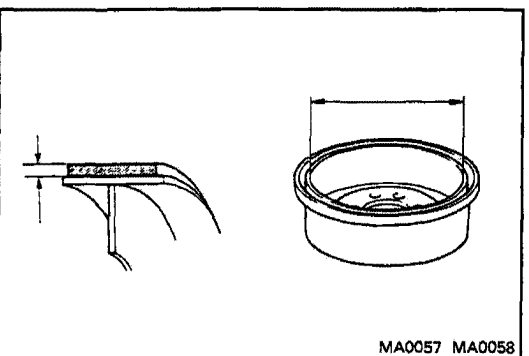

MA0057 MA0058

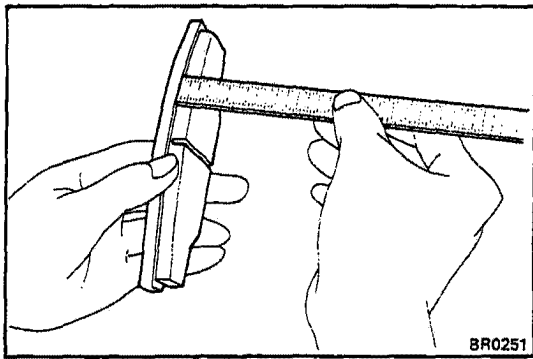

## 15. INSPECT FRONT BRAKE PADS AND DISCS

- (a) Check the thickness of the disc brake pads and check for irregular wear.

**Minimum pad thickness: 4.0 mm (0.158 in.)**

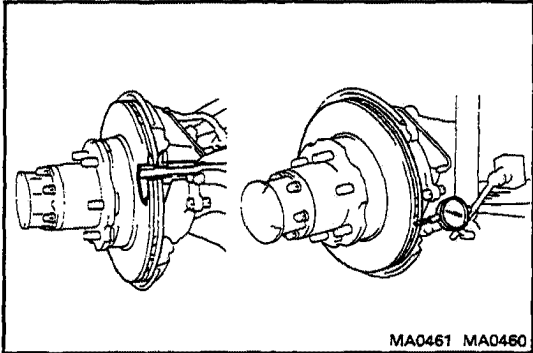

- (b) Check the disc for wear or runout.

**Minimum disc thickness: 19.0 mm (0.748 in.)**

**Maximum disc runout: 0.15 mm (0.0059 in.)**

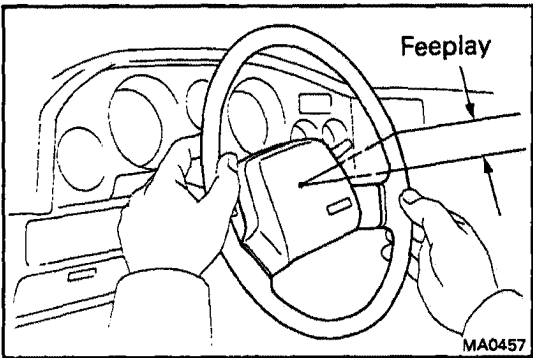

## CHASSIS

### 16. INSPECT STEERING LINKAGE AND DUST COVERS

- (a) Check the steering wheel freeplay.

**Maximum steering wheel freeplay:  
40 mm (1.57 in.)**

With the vehicle stopped and pointed straight ahead, rock the steering wheel gently back and forth with light finger pressure.

- (b) Check the steering linkage for looseness or damage.

Check that:

- Tie rod and relay ends so not have excessive play.
- Dust seals and boots are not damage.

- (c) Inspect the dust cover for damage.

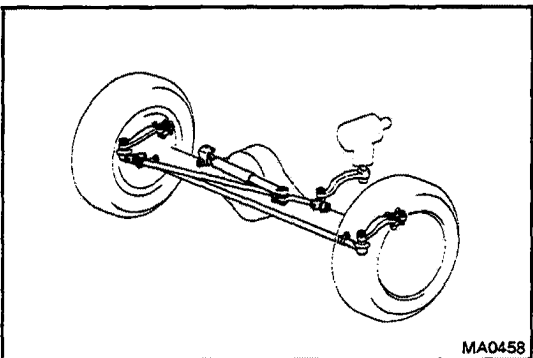

### 17. INSPECT STEERING GEAR HOUSING OIL

Check the steering gear box for oil leakage.

If leakage is found, check for cause and repair.

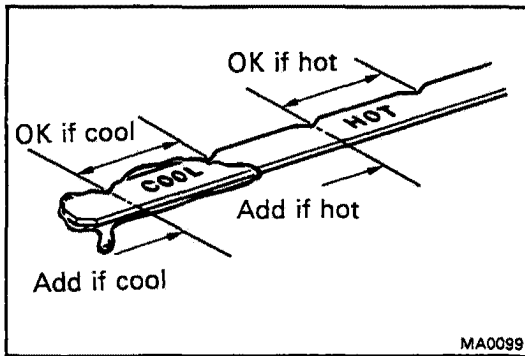

## 18. CHECK OIL LEVEL IN AUTOMATIC TRANSMISSION, TRANSFER AND DIFFERENTIAL OIL

### (a) (Automatic transmission)

Check the automatic transmission for leakage.

If leakage is found, check for cause and repair.

**Transmission fluid: ATF DEXRON® II**

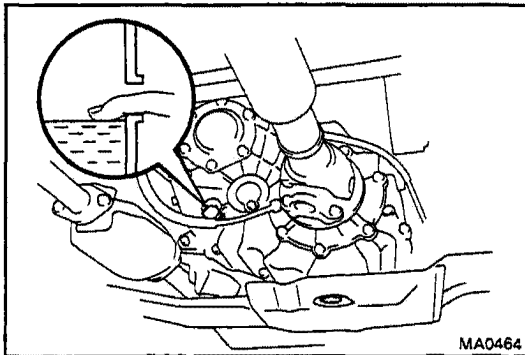

### (b) (Transfer)

Remove the filler plug and feel inside the hole with your finger. Check that the oil comes to within 5 mm (0.20 in.) of the bottom edge of the hole.

If the level is low, add oil until it begins to run out the filler hole.

**Transfer oil:**

**Oil grade API GL-4 or GL-5**

**Viscosity SAE 90**

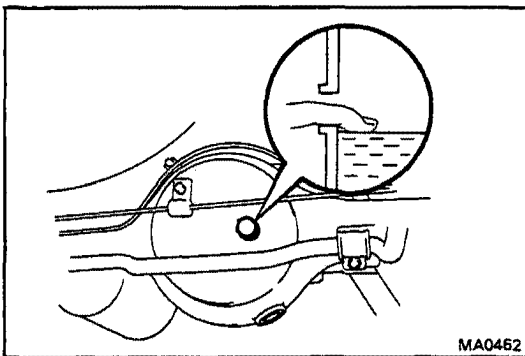

### (c) (Differential)

Remove the filler plug and feel inside the hole with your finger. Check that the oil comes to within 5 mm (0.20 in.) of the bottom edge of the hole.

If the level is low, add oil until it begins to run out the filler hole.

**Differential oil:**

**Oil grade API GL-5 hypoid gear oil**

**Viscosity Above -18°C (0°F) SAE 90**

**Below -18°C (0°F) SAE 80W-90 or 80W**

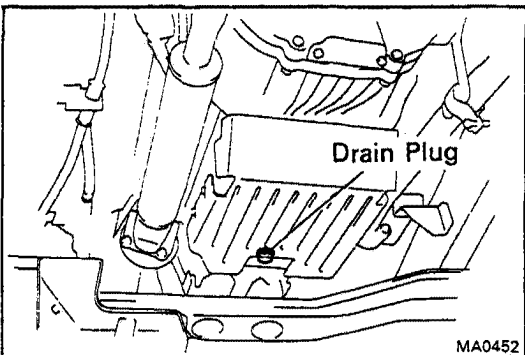

## 19. REPLACE AUTOMATIC TRANSMISSION FLUID

(a) Remove the drain plug and drain the fluid.

(b) Reinstall the drain plug securely.

(c) With the engine "OFF", and new fluid through the dipstick tube.

**Fluid: ATF DEXRON® II**

**Drain and refill capacity (Reference):**

**5.0 liters (5.3 US qts, 4.4 Imp. qts)**

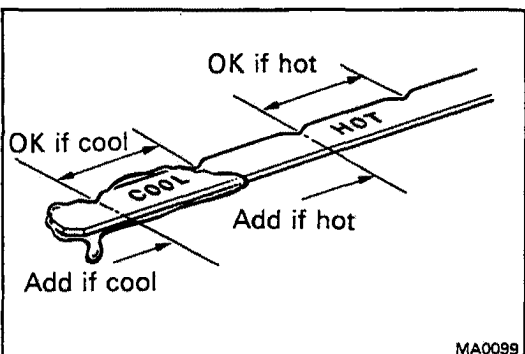

(d) Start the engine and shift the selector into all positions from "P" through "L", and then shift into "P".

(e) With the engine idling, check the fluid level.

Add fluid up to the "COOL" level on the dipstick.

**CAUTION: Do not overfill.**

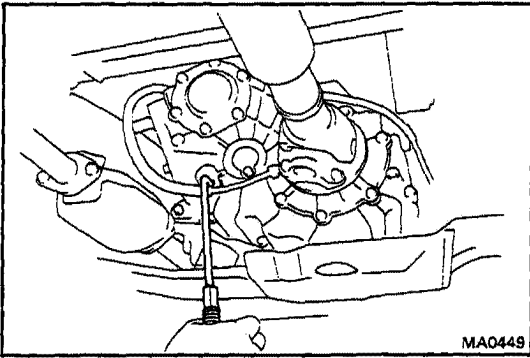

## 20. REPLACE TRANSFER AND DIFFERENTIAL OIL

- (a) Remove the drain plug and drain the oil.
- (b) Reinstall drain plug securely.
- (c) Add new oil until it begins to run out of the filter hole.

**Oil grade and viscosity:** See page MA-9

**Oil capacity:**

**Transfer oil**

2.1 liters (2.2 US qts, 1.8 Imp. qts)

**Differential oil**

**Front** 3.0 liters (3.2 US qts, 2.6 Imp. qts)

**Rear** 2.5 liters (2.6 US qts, 2.2 Imp. qts)

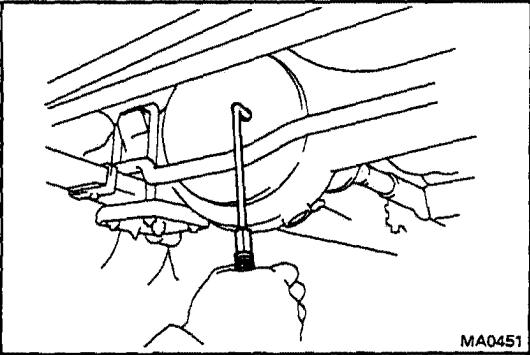

## 21. REPACK FRONT WHEEL BEARINGS

- (a) Change the front wheel bearing grease.
  - Remove the front axle hub and bearings.
  - Wash the inner and outer bearings, and check for damage.
  - Remove the grease from the axle hub and check and check the inner and outer bearing races for damage.
  - Pack the bearings and axle hubs with lithium base multipurpose grease.

**Grease grade:** Lithium base multipurpose grease (NLGI No.2)

- (b) Install the inner bearing and oil seal into the axle hub.
- (c) Install the axle hub, outer bearing and thrust washer, and adjust the wheel bearing preload.
  - Using SST, torque the adjusting nut.

SST 09607-60020

**Torque:** 600 kg-cm (43 ft-lb, 59 N·m)

- Turn the hub right and left two or three times to allow the bearing to settle.
- Using SST, loosen the adjusting nut until it can be turned by hand.

SST 09607-60020

- Using a spring tension gauge, measure the frictional force on the oil seal at the hub bolt.
- Using SST, retighten the adjusting nut.

SST 09607-60020

**Torque:**

40 – 70 kg-cm (35 – 60 in.-lb, 4.0 – 6.8 N·m)

- Check that the bearing has no play.
- Using a spring tension gauge, check the preload.

**Preload (starting):** 2.8 – 5.7 kg  
(6.2 – 12.6 lb, 27 – 56 N)

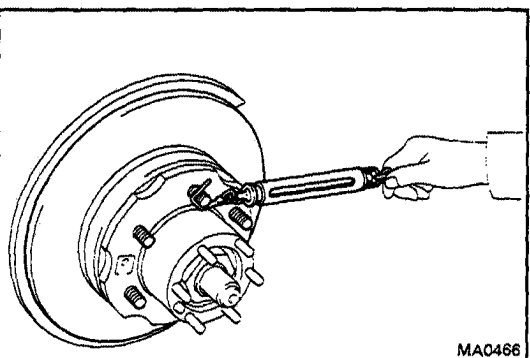
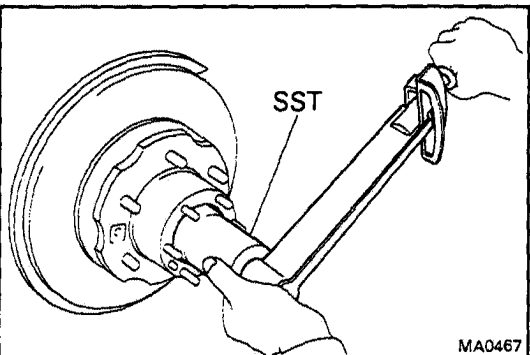
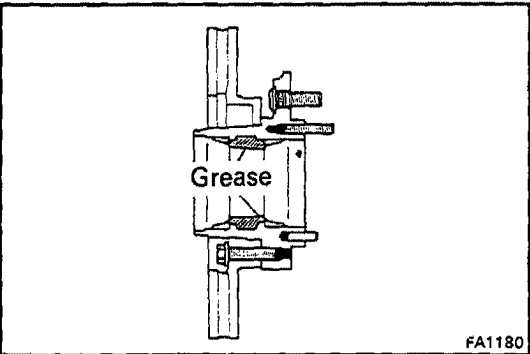

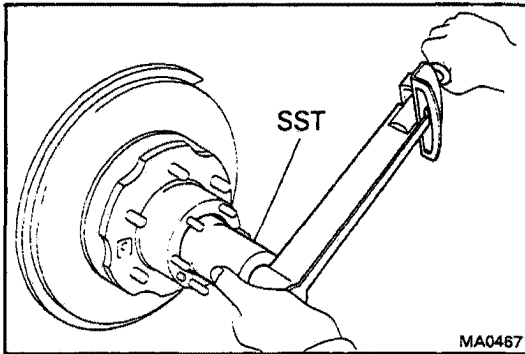

(d) Install a new lock washer and the lock nut.

(e) Using SST, torque the lock nut.

SST 09607-60020

**Torque: 600 kg-cm (43 ft-lb, 59 N·m)**

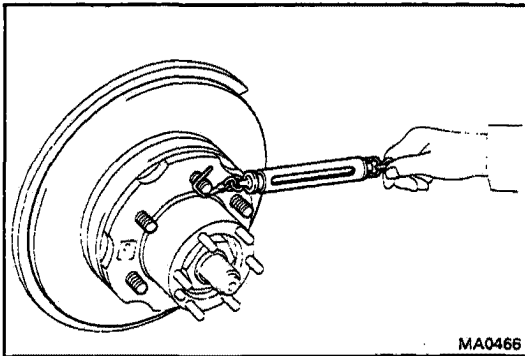

(f) Using a spring tension gauge, recheck the preload.

**Preload (starting): 2.8 – 5.7 kg**

**(6.2 – 12.6 lb, 27 – 56 N)**

If not within specification, adjust with the adjusting nut.

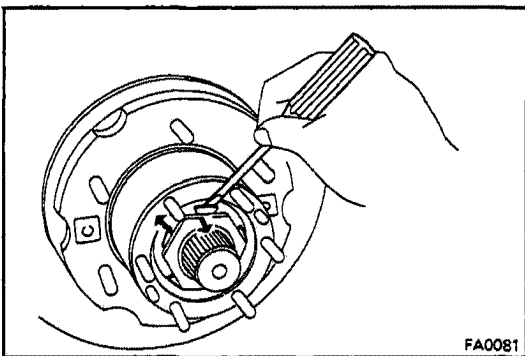

(g) Secure the lock nut by bending one of the lock washer teeth outward and the other lock washer teeth inward.

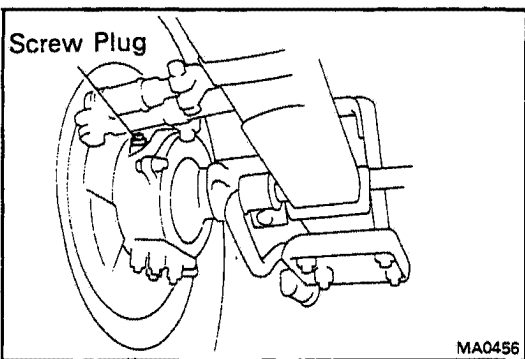

## 22. LUBE STEERING KNUCKLE CHASSIS AND PROPELLER SHAFT

(a) Remove the screw plug from each steering knuckle and repack with lubricant.

**Steering knuckle grease:**

**Molybdenum disulphide lithium base chassis grease (NLGI No. 2)**

(b) Reinstall the two screw plugs.

(c) Lubricate chassis components, referring to the lubrication chart. Before pumping in grease, wipe off any mud and dust on the grease fitting.

**Grease grade**

**Relay rod ends**

**Molybdenum disulphide lithium base chassis grease (NLGI No.2)**

**Propeller shaft**

**Lithium base chassis grease (NLGI No.2)**

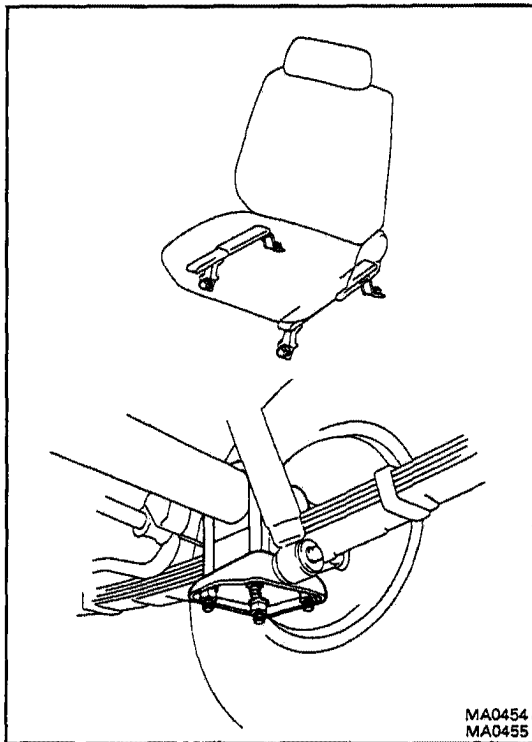
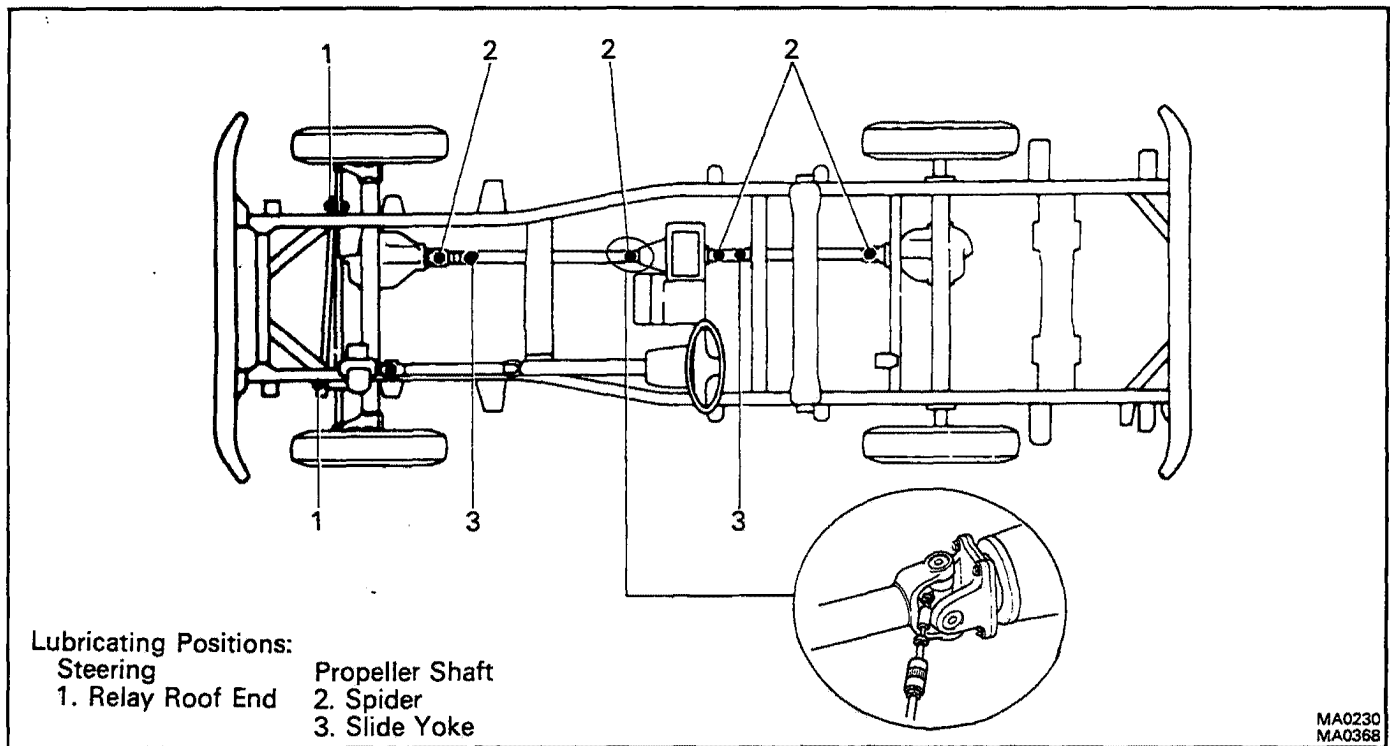

### 23. TIGHTEN BOLTS AND NUTS ON CHASSIS AND BODY

(a) Tighten the following parts:

- Front seats mounting bolts

**Torque: 380 kg-cm (27 ft-lb, 37 N·m)**

- Front and rear leaf spring U-bolt mounting nuts

**Torque: 1,450 kg-cm (105 ft-lb, 142 N·m)**

(b) In addition to the scheduled maintenance items, check for loose or missing bolts and nuts of the following.

- Steering system
- Drive train
- Suspension system
- Fuel tank mounts
- Engine mounts, etc.

**24. FINAL INSPECTION**

- (a) Check the operation of the body parts:
  - Hood
    - Auxiliary catch operation properly
    - Hood locks securely when closed
  - Front and rear doors
    - Door locks operate properly
    - Doors close properly
  - Seats
    - Seat adjusts easily and locks securely in any position
    - Front seat back locks securely in any position
    - Folding-down rear seat backs lock securely
- (b) Road test
  - Check the engine and chassis for abnormal noises.
  - Check that the vehicle does not wander or pull to one side.
  - Check that the brakes work properly and do not drag.
- (c) Be sure to deliver a clean car and especially check:
  - Steering wheel
  - Shift lever knob
  - All switch knobs
  - Door handles
  - Seats

## GENERAL MAINTENANCE

These are maintenance and inspections items which are considered to be the owner's responsibility. They can be performed by the owner or he can have them done at a service shop. These items include those which should be checked on a daily basis, those which, in most cases, do not require (special) tools and those which are considered to be reasonable for the owner to perform. Items and procedures for general maintenance are as follows.

### OUTSIDE VEHICLE

#### 1. TIRES

- (a) Check the pressure with a gauge. If necessary, adjust.
- (b) Check for cuts, damage or excessive wear.

#### 2. WHEEL NUTS

When checking the tires, check the nuts for looseness or for missing nuts. If necessary, tighten them.

#### 3. TIRE ROTATION

It is recommended that the tires be rotated every 7,500 miles (12,000 km)

#### 4. WINDSHIELD WIPER BLADES

Check for wear or cracks whenever they do not wipe clean, If necessary replace.

#### 5. FLUID LEAKS

- (a) Check underneath for leaking fuel, oil, water or other fluid.
- (b) If you smell gasoline fumes or notice any leak, have the cause found and corrected.

#### 6. DOORS AND ENGINE HOOD

- (a) Check that all doors and the tailgate operate smoothly, and that all latches lock securely.
- (b) Check that the engine hood secondary latch secures the hood from opening when the primary latch is released.

### INSIDE VEHICLE

#### 7. LIGHTS

- (a) Check that the headlight, stop light, taillights, turn signal lights, and other lights are all working.

- (b) Check the headlight aim.

#### 8. WARNING LIGHTS AND BUZZERS

Check that all warning lights and buzzers function properly.

#### 9. HORN

Check that it is working.

#### 10. WINDSHIELD GLASS

Check for scratches, pits or abrasions.

#### 11. WINDSHIELD WIPER AND WASHER

- (a) Check operation of the wipers and washer.
- (b) Check that the wipers do not streak.

#### 12. WINDSHIELD DEFROSTER

Check that air comes out from the defroster outlet when operating the heater or air conditioner.

#### 13. REAR VIEW MIRROR

Check that it is mounted securely.

#### 14. SUN VISORS

Check that they move freely and are mounted securely.

#### 15. STEERING WHEEL

Check that it has specified freeplay. Be alert for changes in steering condition, such as hard steering, excessive freeplay or strange noise.

#### 16. SEATS

- (a) Check that the seat adjusters operate smoothly.
- (b) Check that all latches lock securely in any position.
- (c) Check that the head restraints move up and down smoothly and that the locks hold securely in any latched position.
- (d) For fold-down seat backs, check that the latches lock securely.

#### 17. SEAT BELTS

- (a) Check that the seat belt system such as the buckles, retractors and anchors operate properly and smoothly.
- (b) Check that the belt webbing is not cut, frayed, worn or damaged.

**18. ACCELERATOR PEDAL**

Check the pedal for smooth operation and uneven pedal effort or catching.

**19. BRAKE PEDAL**

- (a) Check the pedal for smooth operation.
- (b) Check that the pedal has the proper reserve distance and freeplay.
- (c) Check the brake booster function.

**20. BRAKES**

At a safe place, check that the brakes do not pull to one side when applied.

**21. PARKING BRAKE**

- (a) Check that the lever has the proper travel.
- (b) On a safe incline, check that vehicle is held securely with only the parking brake applied.

**22. AUTOMATIC TRANSMISSION "PARK" MECHANISM**

- (a) Check the lock release button of the selector lever for proper and smooth operation.
- (b) On a safe incline, check that vehicle is held securely with the selector lever in "P" position and all brakes released.

**UNDER HOOD****23. WINDSHIELD WASHER FLUID**

Check that there is sufficient fluid in the tank.

**24. ENGINE COOLANT LEVEL**

Check that the coolant level is between the "FULL" and "LOW" lines on the see-through reservoir.

**25. RADIATOR AND HOSES**

- (a) Check that the front of the radiator is clean and not blocked with leaves, dirt or bugs.
- (b) Check the hoses for cracks, kinks, rot or loose connections.

**26. BATTERY ELECTROLYTE LEVEL**

Check that the electrolyte level of all battery cells is between the upper and lower level lines on the case. If level is low, add distilled water only.

**27. BRAKE FLUID LEVEL**

Check that the brake fluid level is near the upper level line on the see-through reservoir.

**28. ENGINE DRIVE BELTS**

Check all drive belts for fraying, cracks, wear or oiliness.

**29. ENGINE OIL LEVEL**

Check the level on the dipstick with the engine turned off.

**30. POWER STEERING FLUID LEVEL**

Check the level on the dipstick. The level should be in the "HOT" or "COLD" range depending on the fluid temperature.

**31. AUTOMATIC TRANSMISSION FLUID LEVEL**

- (a) Park the vehicle on a level surface.
- (b) With the engine idling and the parking brake applied, shift the selector into all positions from "P" to "L", and then shift into "P".
- (c) Pull out the dipstick and wipe off the fluid with a clean rag. Re-insert the dipstick and check that the fluid level is in the HOT range.
- (d) Perform this check with the fluid at normal driving temperature (70 –80°C or 158 – 176°F).

NOTE: Wait until the engine cools down (approx. 30 min.) before checking the fluid level after extended high speed driving in hot weather, driving in heavy traffic or pulling a trailer.

**32. EXHAUST SYSTEM**

Visually inspect for cracks, holes or loose supports.

If any change in the sound of the exhaust or smell of the exhaust fumes is noticed, have the cause located and corrected.

- MEMO -

---

---

# ENGINE MECHANICAL

	<b>Page</b>
TRUBLESHOOTING .....	EM-2
ENGINE TUNE-UP .....	EM-6
COMPRESSION CHECK .....	EM-10
CYLINDER HEAD .....	EM-11
TIMING GEARS AND CAMSHAFT .....	EM-33
CYLINDER BLOCK .....	EM-45



## TROUBLESHOOTING ENGINE OVERHEATING

Problem	Possible cause	Remedy	Page
Engine overheats	Cooling system faulty Incorrect ignition timing	Troubleshoot cooling system Reset timing	CO-2 IG-11

## HARD STARTING

Problem	Possible cause	Remedy	Page
Engine will not crank or cranks slowly	Starting system faulty	Troubleshoot starting system	ST-2
Engine will not start/ hard to start (cranks OK)	No fuel supply to injector <ul style="list-style-type: none"> <li>● No fuel in tank</li> <li>● Fuel pump no working</li> <li>● Fuel filter clogged</li> <li>● Fuel line clogged or leaking</li> </ul>	Troubleshoot EFI system	FI-9
	EFI system problems	Repair as necessary	IG-5
	Ignition problems <ul style="list-style-type: none"> <li>● Ignition coil</li> <li>● Igniter</li> <li>● Distributor</li> </ul>	Perform spark test	
	Spark plug faulty	Inspect plugs	IG-6
	High-tension cords disconnected broken	Inspect cords	IG-6
	Vacuum leaks <ul style="list-style-type: none"> <li>● PCV line</li> <li>● EGR line</li> <li>● Intake manifold</li> <li>● Air intake chamber</li> <li>● Throttle body</li> <li>● ISC valve</li> <li>● Brake booster line</li> </ul>	Repair as necessary	EM-10
Pulling in air between air flow meter and throttle body	Repair as necessary		
Low compression	Check compression		

## ROUGH IDLING

Problem	Possible cause	Remedy	Page
Rough idle, stalls or misses	Spark plug faulty	Inspect plugs	IG-6
	High-tension cord faulty	Inspect cords	IG-6
	Ignition problems <ul style="list-style-type: none"> <li>● Ignition coil</li> <li>● Igniter</li> <li>● Distributor</li> </ul>	Inspect coil	IG-7
		Inspect igniter	IG-7
		Inspect distributor	IG-7
	Incorrect ignition timing	Reset timing	IG-11
	Vacuum leaks <ul style="list-style-type: none"> <li>● PCV line</li> <li>● EGR line</li> <li>● Intake manifold</li> <li>● Air intake chamber</li> </ul>	Repair as necessary	

**ROUGH IDLING (Cont'd)**

<b>Problem</b>	<b>Possible cause</b>	<b>Remedy</b>	<b>Page</b>
Rough idle, stalls or misses (Cont'd)	<ul style="list-style-type: none"> <li>● Throttle body</li> <li>● ISC valve</li> <li>● Brake booster line</li> </ul> Pulling in air between air flow meter and throttle body Incorrect idle speed Incorrect valve clearance EFI system problems Engine overheats Low compression	Check ISC system Adjust valve clearance Repair as necessary Check cooling system Check compression	FI-40,71 EM-7 CO-2 EM-10

**ENGINE HESITATES/POOR ACCELERATION**

<b>Problem</b>	<b>Possible cause</b>	<b>Remedy</b>	<b>Page</b>
Engine hesitates/ poor acceleration	Spark plug faulty	Inspect plugs	IG-6
	High-tension cord faulty	Inspect cords	IG-6
	Vacuum leaks	Repair as necessary	
	<ul style="list-style-type: none"> <li>● PCV line</li> <li>● EGR line</li> <li>● Intake manifold</li> <li>● Air intake chamber</li> <li>● Throttle body</li> <li>● ISC valve</li> <li>● Brake booster line</li> </ul>		
	Pulling in air between air flow meter and throttle body	Repair as necessary	
	Incorrect ignition timing	Reset timing	IG-11
	Incorrect valve clearance	Adjust valve clearance	EM-7
	Fuel system clogged	Check fuel system	
	Air cleaner clogged	Check air cleaner	MA-5
	EFI system problems	Repair as necessary	
	Emission control system problem (Cold engine)		
	<ul style="list-style-type: none"> <li>● EGR system always on</li> </ul>	Check EGR system	EC-11
	Engine overheats	Check cooling system	CO-2
Low compression	Check compression	EM-10	

## ENGINE DIESELING

Problem	Possible cause	Remedy	Page
Engine diesels (runs after ignition switch turned off)	EFI system problems	Repair as necessary	

## AFTER FIRE, BACKFIRE

Problem	Possible cause	Remedy	Page
Muffler explosion (after fire) on deceleration only	Deceleration fuel cut system always off	Check EFI (fuel cut) system	
Muffler explosion (after fire) all the time	Air cleaner clogged EFI system problem Incorrect ignition timing	Check air cleaner Repair as necessary Reset timing	MA-5 IG-11
Engine backfires	EFI system problem Vacuum leak <ul style="list-style-type: none"> <li>● PCV line</li> <li>● EGR line</li> <li>● Intake manifold</li> <li>● Air intake chamber</li> <li>● Throttle body</li> <li>● ISC valve</li> <li>● Brake booster line</li> </ul> Pulling in air between air flow meter and throttle body Insufficient fuel flow Incorrect ignition timing Incorrect valve clearance Carbon deposits in combustion chambers	Repair as necessary Check hoses and repair as necessary  Repair as necessary  Troubleshoot fuel system Reset timing Adjust valve clearance Inspect cylinder head	     FI-9 IG-11 EM-7 EM-11

## EXCESSIVE OIL CONSUMPTION

Problem	Possible cause	Remedy	Page
Excessive oil consumption	Oil leak PCV line clogged Piston ring worn or damaged Valve stem and guide bushing worn Valve stem oil seal worn	Repair as necessary Check PCV system Check rings Check valves and guide bushing Check seals	EC-4 EM-60 EM-18

**POOR GASOLINE MILEAGE**

<b>Problem</b>	<b>Possible cause</b>	<b>Remedy</b>	<b>Page</b>
Poor gasoline mileage	Fuel leak	Repair as necessary	
	Air cleaner clogged	Check air cleaner	MA-5
	Incorrect ignition timing	Reset timing	IG-11
	EFI system problems <ul style="list-style-type: none"> <li>● Injector faulty</li> <li>● Deceleration fuel cut system faulty</li> </ul>	Repair as necessary	
	Idle speed too high	Check ISC system	FI-40,71
	Spark plug faulty	Inspect plugs	IG-6
	EGR system always on	Check EGR system	EC-11
	Low compression	Check compression	EM-10
	Tires improperly inflated	Inflate tires to proper pressure	
	Brakes drag	Troubleshoot brakes	

**UNPLEASANT ODOR**

<b>Problem</b>	<b>Possible cause</b>	<b>Remedy</b>	<b>Page</b>
Unpleasant odor	Incorrect idle speed	Check ISC system	FI-40,71
	Incorrect ignition timing	Reset timing	IG-11
	Vacuum leaks <ul style="list-style-type: none"> <li>● PCV line</li> <li>● EGR line</li> <li>● Intake manifold</li> <li>● Air intake chamber</li> <li>● Throttle body</li> <li>● ISC valve</li> <li>● Brake booster line</li> </ul>	Repair as necessary	
	EFI system problems	Repair as necessary	

## **ENGINE TUNE-UP**

### **INSPECTION OF ENGINE COOLANT**

(See steps 1 and 2 on page CO-3)

### **INSPECTION OF ENGINE OIL**

(See steps 1 and 2 on page LU-3)

### **INSPECTION OF AIR FILTER**

(See step 3 on page MA-5)

### **INSPECTION OF BATTERY**

(See steps 1 and 2 on page CH-3)

Standard specific gravity:

1.25 – 1.27 when fully charged at 20°C (68°F)

### **INSPECTION OF HIGH-TENSION CORDS**

(See page IG-6)

Maximum resistance: 25 k $\Omega$  per cord

### **INSPECTION OF SPARK PLUGS**

(See page IG-6)

Recommended spark plug: ND W16EXR-U  
NGK BPR5EY

Correct electrode gap: 0.8 mm (0.031 in.)

### **INSPECTION OF ALTERNATOR DRIVE BELT**

(See page CH-3)

Drive belt tension:

New belt 145  $\pm$  25 lb

Used belt 100  $\pm$  20 lb

## INSPECTION AND ADJUSTMENT OF VALVE CLEARANCE

NOTE: Inspect and adjust the valve clearance after engine has reached normal operating temperature.

1. REMOVE AIR CLEANER HOSE
2. REMOVE CYLINDER HEAD COVER  
(See step 21 on page EM-14)
3. SET NO.1 CYLINDER TO TDC/COMPRESSION
  - (a) Align the TDC mark of the drive plate with the timing pointer by turning the crankshaft clockwise with a wrench.
  - (b) Check that the rocker arms on the No. 1 cylinder are loose and rocker arms on the No. 6 are tight.

If not, turn the crankshaft one revolution (360°) and align the mark as above.

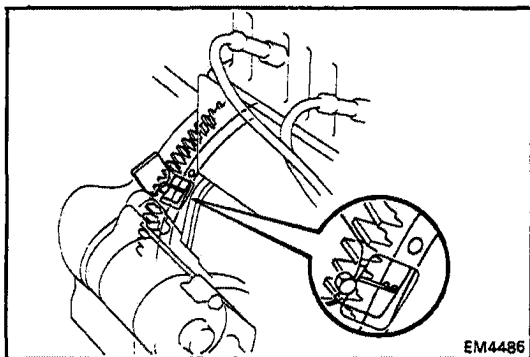

EM4486

4. INSPECT AND ADJUST VALVE CLEARANCE
  - (a) Measure only those valves indicated by arrows.

Valve clearance (Hot):

Intake	0.20 mm (0.008 in.)
Exhaust	0.35 mm (0.014 in.)

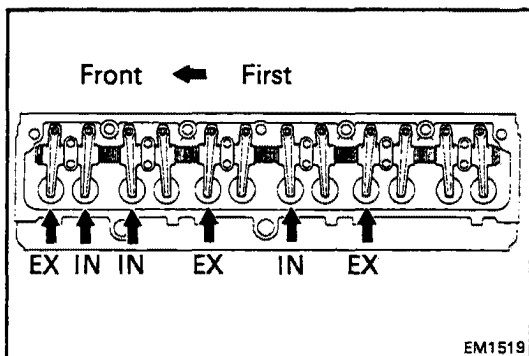

EM1519

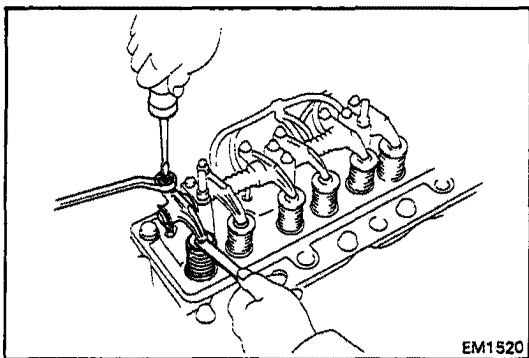

EM1520

- Using a thickness gauge, measure the valve clearance between the valve stem and rocker arm. Loosen the lock nut and turn the adjusting screw to set the proper clearance. Hold the adjusting screw in position and tighten the lock nut.
- Recheck the valve clearance. The thickness gauge should slide with a very slight drag.

- (b) Turn the crankshaft pulley one revolution (360°) and align the mark as above. Adjust only the valves indicated by arrows.

5. INSTALL CYLINDER HEAD COVER  
(See step 6 on page EM-29)
6. INSTALL AIR CLEANER HOSE

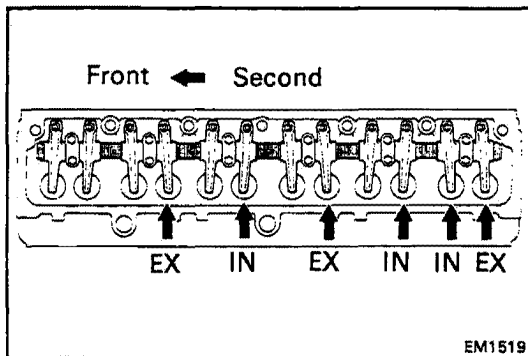

EM1519

## INSPECTION AND ADJUSTMENT OF IGNITION TIMING

(See steps 10 to 14 on page IG-11)

Ignition timing:

7° BTDC @ idle

(w/ Terminals TE1 and E1 short-circuited)

## IDLE HC/CO CONCENTRATION CHECK METHOD

NOTE: This check is used only to determine whether or not the idle HC/CO complies with regulations.

### 1. INITIAL CONDITIONS

- (a) Engine at normal operating temperature
- (b) Air cleaner installed
- (c) All pipes and hoses of air induction system connected
- (d) All accessories switched OFF
- (e) All vacuum lines properly connected

NOTE: All vacuum hoses for EGR systems, etc. should be properly connected.

- (f) EFI system wiring connectors fully plugged
- (g) Ignition timing set correctly
- (h) Transmission in "N" range
- (i) Tachometer and HC/CO meter at hand and calibrated

### 2. START ENGINE

### 3. CHECK OXYGEN SENSORS OPERATION

- (a) Using a service wire, short terminals TE1 and E1 of the check connector.
- (b) Connect the positive (+) probe of a voltmeter to terminal VF1 (VF2) of the check connector, and negative (-) probe to terminal E1.
- (c) Hold the engine speed at 2,500 rpm for approx. 2 minutes.
- (d) Then, maintaining engine at 2,500 rpm, count how many times needle of voltmeter fluctuates between 0 and 5 V.

Minimum needle fluctuation:

**8 times for every 10 seconds**

If the fluctuation is less than minimum, check the air induction system for leakage. If necessary, see EFI SYSTEM.

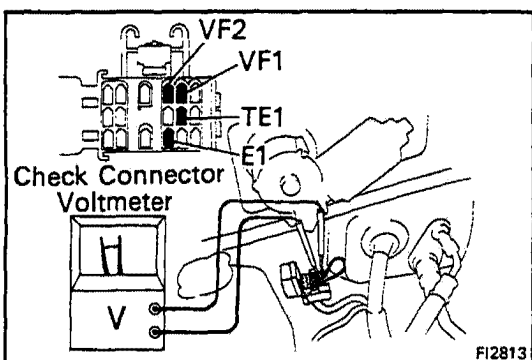
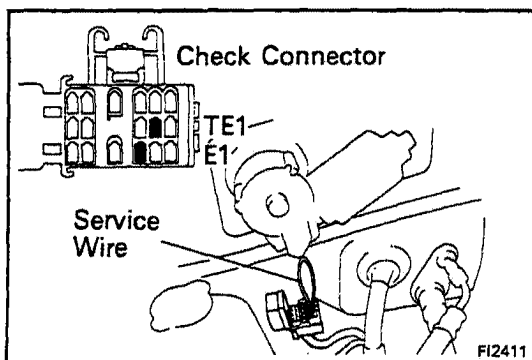

**4. RACE ENGINE AT 2,500 RPM FOR APPROX. 2 MINUTES**

**5. INSERT HC/CO METER TESTING PROBE INTO TAIL PIPE AT LEAST 40 cm (1.3 ft)**

**6. MEASURE HC/CO CONCENTRATION AT IDLE**

Wait at least one minute before measuring to allow the concentration to stabilize.

Complete the measuring within three minutes.

If the HC/CO concentration does not conform to regulations, see the table blow for possible causes.

### Troubleshooting

HC	CO	Problem	Cause
High	Normal	Rough idle	<ol style="list-style-type: none"> <li>1. Faulty ignition: <ul style="list-style-type: none"> <li>● Incorrect timing</li> <li>● Fouled, shorted or improperly gapped plugs</li> <li>● Open or crossed high-tension cords</li> <li>● Cracked distributor cap</li> </ul> </li> <li>2. Incorrect valve clearance</li> <li>3. Leaky EGR valve</li> <li>4. Leaky intake and exhaust valves</li> <li>5. Leaky cylinder</li> </ol>
High	Low	Rough idle (Fluctuating HC reading)	<ol style="list-style-type: none"> <li>1. Vacuum leak: <ul style="list-style-type: none"> <li>● PCV hose</li> <li>● EGR valve</li> <li>● Intake manifold</li> <li>● Air intake chamber</li> <li>● Throttle body</li> <li>● ISC valve</li> <li>● Brake booster line</li> </ul> </li> <li>2. Lean mixture causing misfire</li> </ol>
High	High	Rough idle (Black smoke from exhaust)	<ol style="list-style-type: none"> <li>1. Restrivted air filter</li> <li>2. Faulty EFI system <ul style="list-style-type: none"> <li>● Faulty pressure regulator</li> <li>● Clogged fuel return line</li> <li>● Defective water temp. sensor</li> <li>● Defective air temp. sensor</li> <li>● Faulty ECU</li> <li>● Faulty injector</li> <li>● Faulty cold start injector</li> <li>● Faulty throttle position sensor</li> <li>● Air flow meter</li> </ul> </li> </ol>

## COMPRESSION CHECK

**NOTE:** If there is lack of power, excessive oil consumption or poor fuel economy, measure the cylinder compression pressure.

1. **WARM UP AND STOP ENGINE**
2. **DISCONNECT DISTRIBUTOR CONNECTOR**
3. **DISCONNECT COLD START INJECTOR CONNECTOR**
4. **REMOVE SPARK PLUGS**
5. **CHECK CYLINDER COMPRESSION PRESSURE**

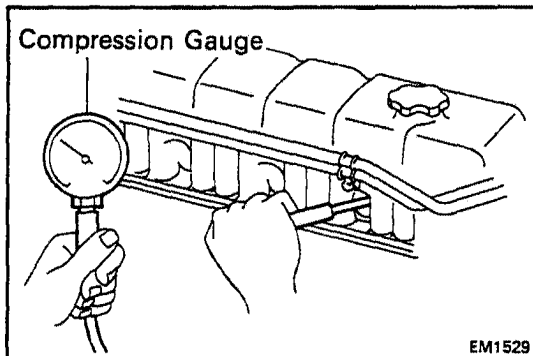

- (a) Insert a compression gauge into the spark plug hole.
- (b) Fully open the throttle valve.
- (c) While cranking the engine with the starter, measure the compression pressure.

**NOTE:** Always use a fully charged battery to obtain engine revolutions of more than 200 rpm.

**CAUTION:** This measurement must be done for as short time as possible.

- (d) Repeat steps (a) through (c) for each cylinder.

**Compression pressure:**

**10.5 kg/cm<sup>2</sup> (149 psi, 1,030 kPa) or more**

**Minimum pressure:**

**8.0 kg/cm<sup>2</sup> (114 psi, 785 kPa)**

**Difference between each cylinder:**

**0.5 kg/cm<sup>2</sup> (7 psi, 49 kPa) or less**

- (e) If compression of one or more cylinders is low, pour a small amount of engine oil into that cylinder through the spark plug hole and repeat steps (a) through (c) for the cylinder with low compression.
  - If adding oil helps the compression, probably the piston rings and / or cylinder bore are worn or damaged.
  - If pressure stays low, a valve may be sticking or seated improperly, or there may be leakage past the gasket surface.

6. **REINSTALL SPARK PLUGS**  
Torque: 180 kg-cm (13 ft-lb, 18 N·m)
7. **RECONNECT COLD START INJECTOR CONNECTOR**
8. **RECONNECT DISTRIBUTOR CONNECTOR**

# CYLINDER HEAD COMPONENTS

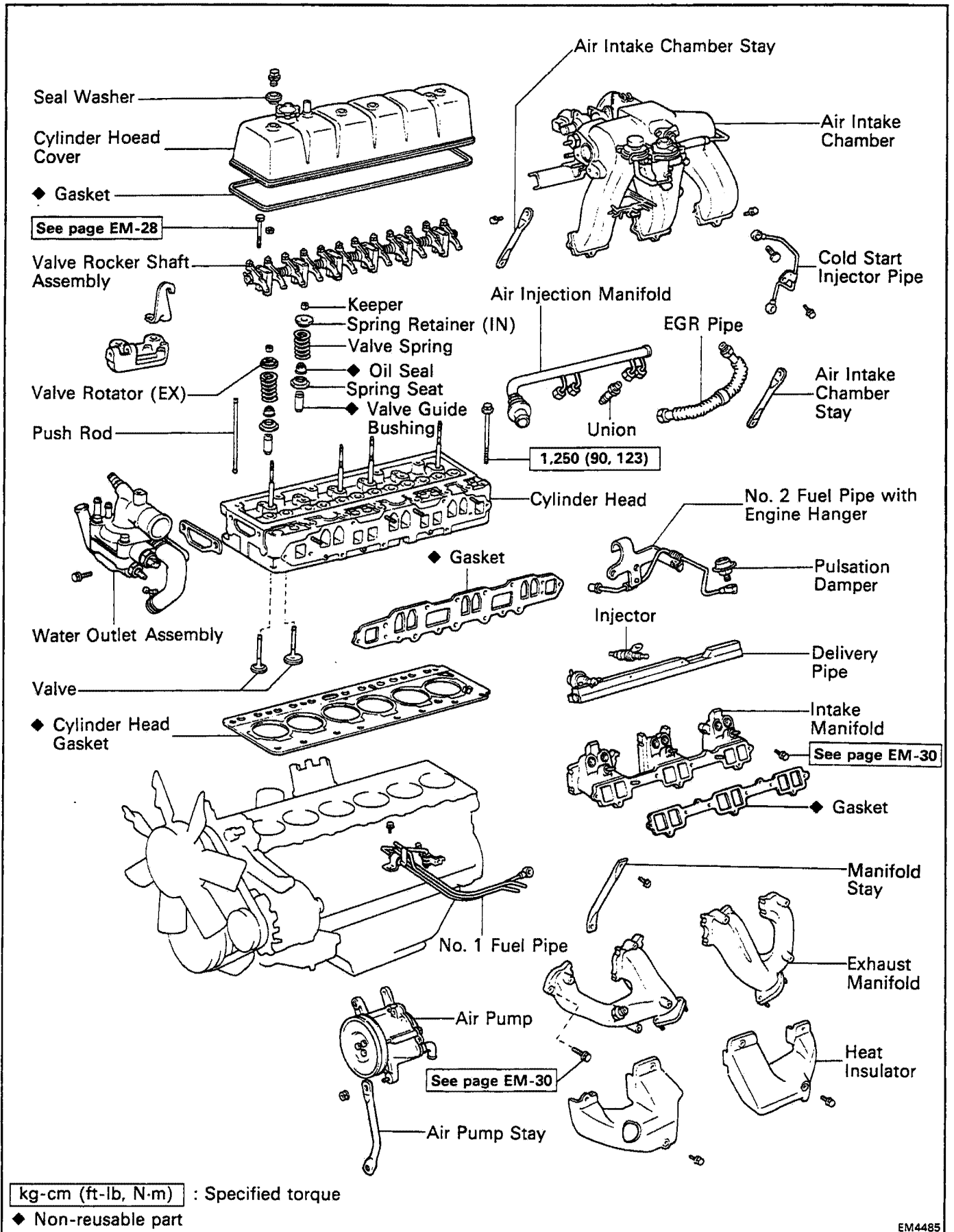

kg-cm (ft-lb, N-m) : Specified torque

◆ Non-reusable part

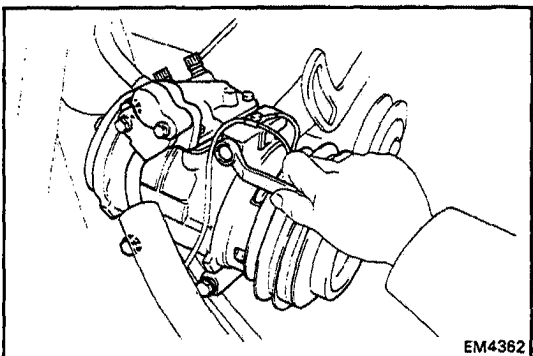
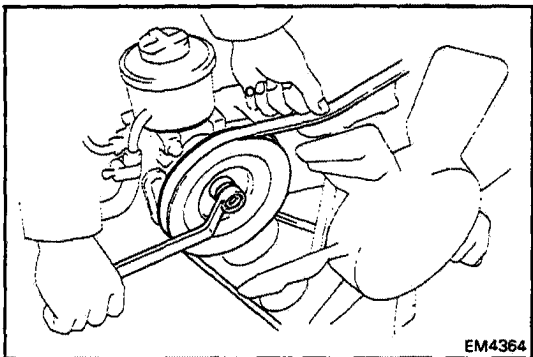
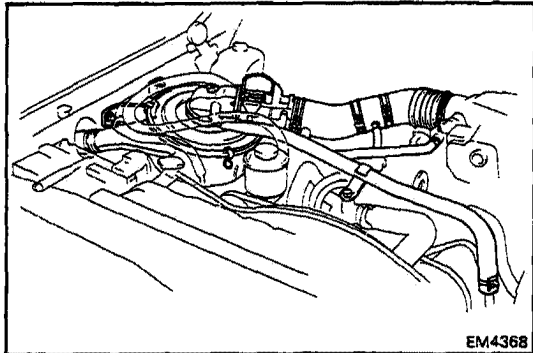
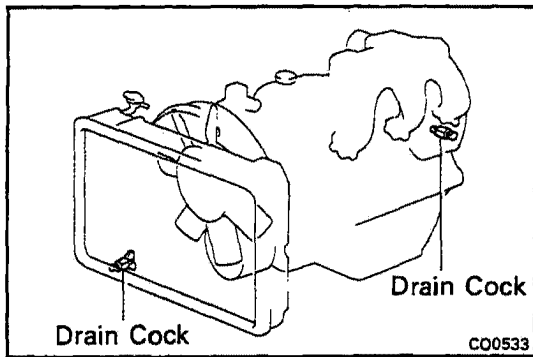

## REMOVAL OF CYLINDER HEAD

(See page EM-11)

1. **DRAIN ENGINE COOLANT**  
(See page CO-3)
2. **DISCONNECT CABLE FROM NEGATIVE TERMINAL**
3. **REMOVE HOOD**
4. **DISCONNECT ACCELERATOR AND THROTTLE CABLES**
5. **REMOVE AIR INTAKE HOSE, AIR FLOW METER AND AIR CLEANER CAP**
  - (a) Disconnect the air flow meter connector and clamp.
  - (b) Disconnect following hoses:
    - ISC hose
    - Air pump hose
    - Distributor hose
    - PCV hose
    - Three hoses from the intake chamber rear side
    - Two hoses from the VCV of the charcoal canister
  - (c) Loosen the air intake hose clamp.
  - (d) Remove the wing nut and loosen the three clips, and remove the air intake hose, air flow meter and air cleaner cap.
6. **REMOVE PS PUMP WITHOUT DISCONNECTING HOSES**
  - (a) Push on the drive belt to hold the pulley in place and loosen the pulley nut.
  - (b) Loosen the idler pulley and adjusting bolts, and remove the drive belt.
  - (c) Remove the drive pulley and woodruff key.
  - (d) Remove PS mount bolts, and remove the PS pump from the bracket.
7. **REMOVE A/C COMPRESSOR WITHOUT DISCONNECTING HOSES**
  - (a) Disconnect the connector.
  - (b) Loosen the idler pulley nut.
  - (c) Screw in the adjusting bolt, and remove the drive belt.
  - (d) Remove the four compressor mount bolts.
  - (e) Put aside the compressor, and suspend it to the fender apron with the string.
8. **REMOVE PS PUMP AND A/C COMPRESSOR BRACKETS**

**9. DISCONNECT HIGH-TENSION CORDS FROM SPARK PLUGS AND IGNITION COIL**

**10. REMOVE HEATER WATER (OIL COOLER) PIPE**

- (a) Disconnect the hoses from the water outlet, water pump, oil cooler and heater water pipe.
- (b) Remove the bolts and heater water (oil cooler) pipe from the cylinder head.

**11. DISCONNECT RADIATOR UPPER HOSE**

**12. DISCONNECT FUEL HOSES**

**13. RAISE VEHICLE**

**CAUTION:** Be sure the vehicle is securely supported.

**14. DISCONNECT EXHAUST PIPE FROM EXHAUST MANIFOLD**

- (a) Loosen the bolt and disconnect the clamp from the bracket.
- (b) Remove the four nuts, and disconnect the exhaust pipe.

**15. REMOVE AIR PUMP**

- (a) Disconnect the air hose.
- (b) Remove the bolt, nut and air pump stay.
- (c) Remove the through bolt, nut and air pump.

**16. REMOVE DELIVERY PIPE AND INJECTORS  
(See steps 4 to 9 on pages FI-58, 59)**

**17. REMOVE AIR INJECTION MANIFOLD**

Remove the two bolts, four union nuts and air injection manifold.

**18. REMOVE INTAKE AND EXHAUST MANIFOLDS**

- (a) Remove the two bolts and manifold stay.
- (b) Remove the six bolts and three manifold heat insulators.

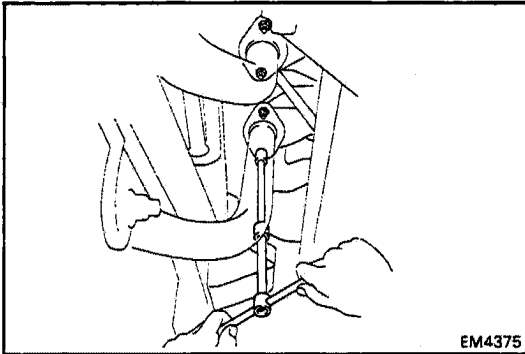

EM4375

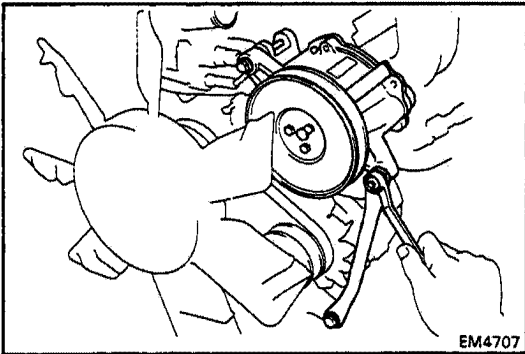

EM4707

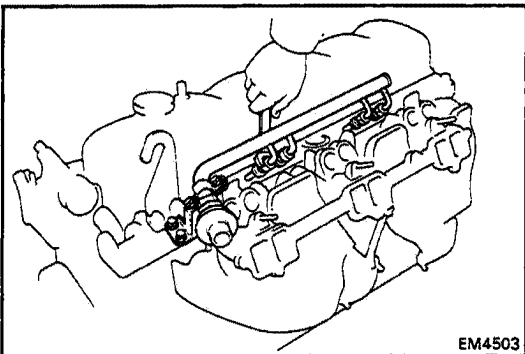

EM4503

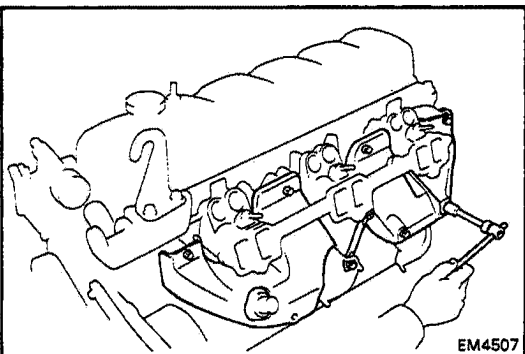

EM4507

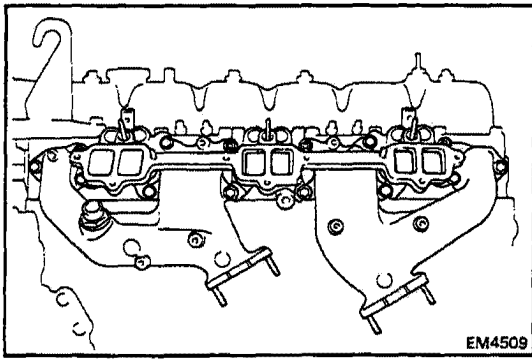

- (c) Remove the ten bolts, four nuts, intake manifold, exhaust manifolds and gasket.

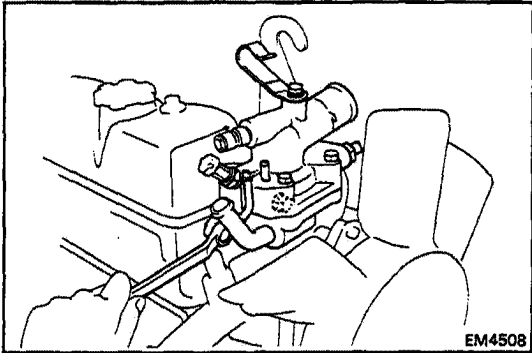

### 19. REMOVE WATER OUTLET ASSEMBLY

- (a) Disconnect the water by-pass hose from the water outlet.  
 (b) Remove the two bolts holding the water outlet housing to the cylinder head, and remove the water outlet assembly and gasket.

### 20. REMOVE SPARK PLUGS

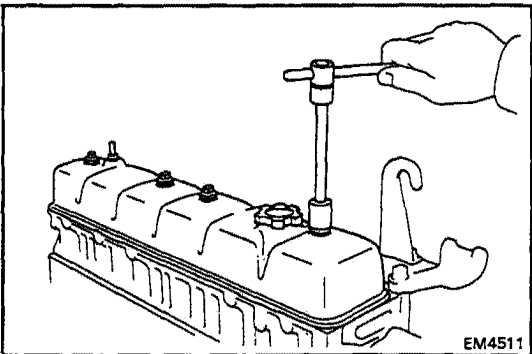

### 21. REMOVE CYLINDER HEAD COVER

- Remove the four cap nuts, seal washers, cylinder head cover and gasket.

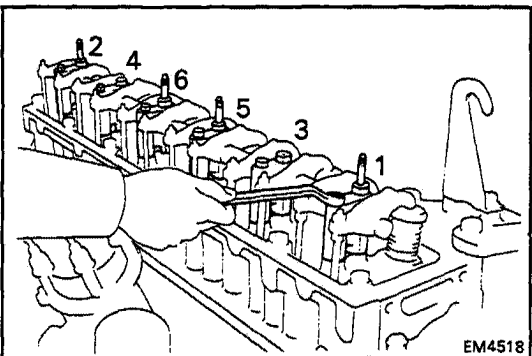

### 22. REMOVE VALVE ROCKER SHAFT ASSEMBLY

- (a) Uniformly loosen and remove the eight bolts and four nuts in several passes, in the sequence shown.  
 (b) Remove the rocker shaft assembly.

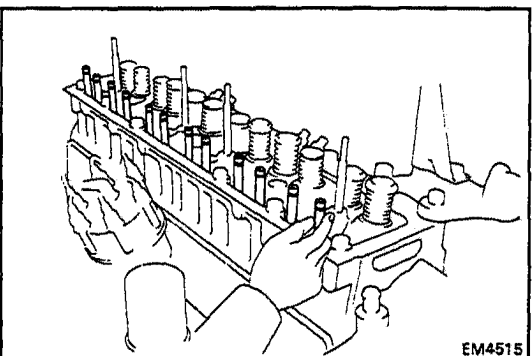

### 23. REMOVE PUSH RODS

- Remove the twelve push rods in order, beginning from the No. 1 push rod.

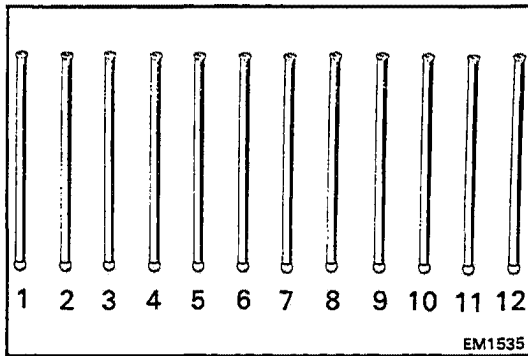

NOTE: Arrange the push rods in correct order.

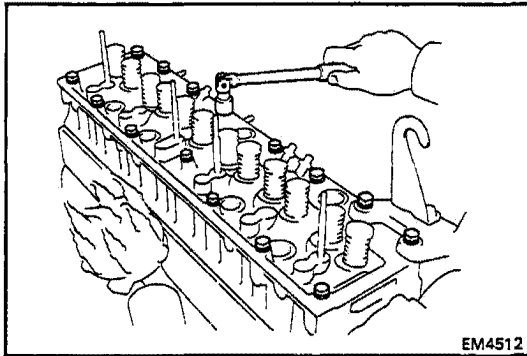

## 24. REMOVE CYLINDER HEAD

(a) Uniformly loosen and remove the fifteen head bolts in several passes, in the sequence shown.

**CAUTION:** Head warpage or cracking could result from removing the bolts in incorrect order.

(b) Remove the air pump bracket with engine hanger.

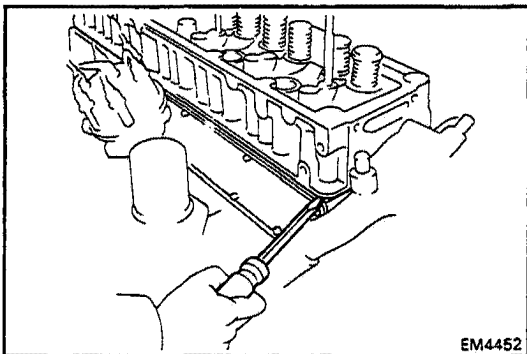

(c) Lift the cylinder head from the dowels on the cylinder block and place it on wooden blocks on a bench.

NOTE: If the cylinder head is difficult to lift off, pry with a screwdriver between the cylinder head and block saliences.

**CAUTION:** Be careful not to damage the cylinder head and block surface on the cylinder and head gasket sides.

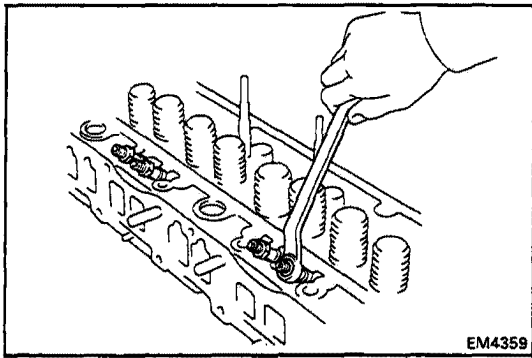

## DISASSEMBLY OF CYLINDER HEAD

(See page EM-11)

### 1. REMOVE AIR INJECTION MANIFORLD UNIONS

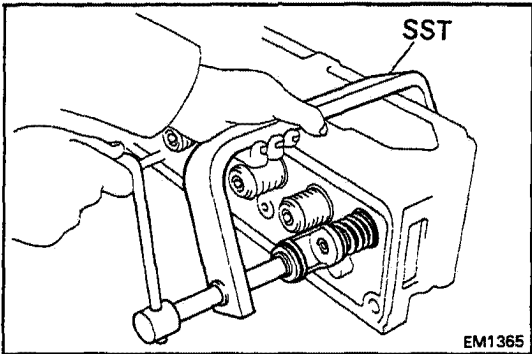

### 2. REMOVE VALVES

(a) Using SST, press the valve springs and remove the two keepers.

SST 09202-43013

(b) Remove the spring retainer (or valve rotator), valve springs and valve.

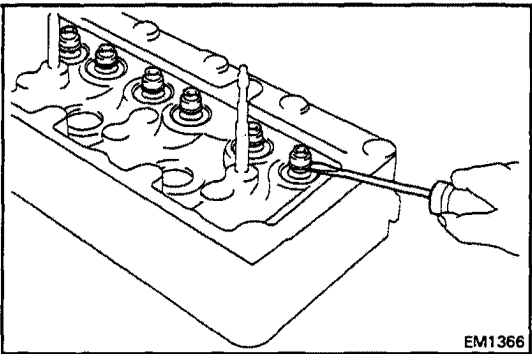

(c) Using a screwdriver, pry out the valve stem oil seal.

(d) Remove the valve spring seat.

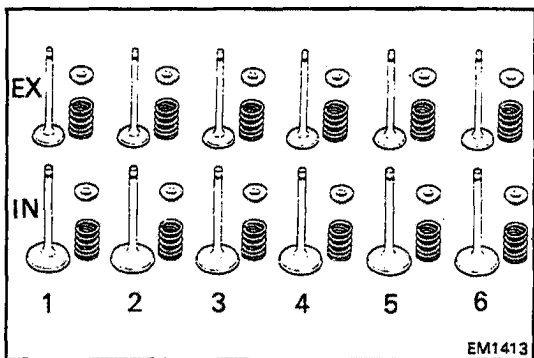

**NOTE:** Arrange the valves, valve springs and spring retainers (or valve rotators) in correct order.

## INSPECTION, CLEANING AND REPAIR OF CYLINDER HEAD COMPONENTS

### 1. CLEAN TOP OF PISTONS AND TOP OF BLOCK

- (a) Turn the crankshaft and bring each piston to top dead center. Using a gasket scraper, remove all the carbon from the piston top.
- (b) Remove all the gasket material from the top of the block.
- (c) Blow carbon and oil from the bolt holes.

**WARNING:** Protect your eyes when using high pressure air.

### 2. REMOVE GASKET MATERIAL

Using a gasket scraper, remove all the gasket material from the manifold and head surface.

**CAUTION:** Be careful not to scratch the surfaces.

### 3. CLEAN COMBUSTION CHAMBERS

Using a wire brush, remove all the carbon from the combustion chambers.

**CAUTION:** Be careful not to scratch the head gasket contact surface.

### 4. CLEAN VALVE GUIDE BUSHINGS

Using a valve guide bushing brush and solvent, clean all the guide bushings.

### 5. CLEAN CYLINDER HEAD

Using a soft brush and solvent, thoroughly clean the head.

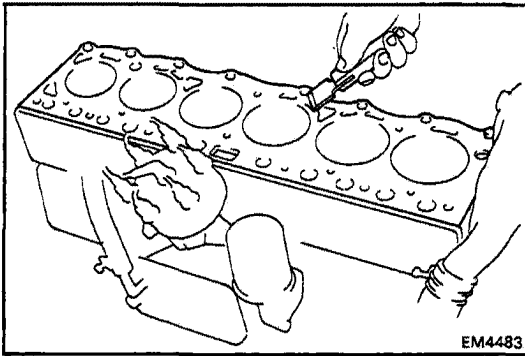

EM4483

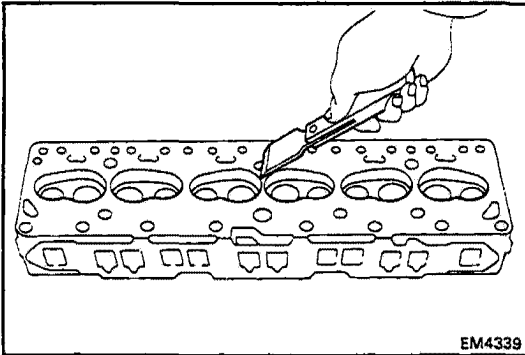

EM4339

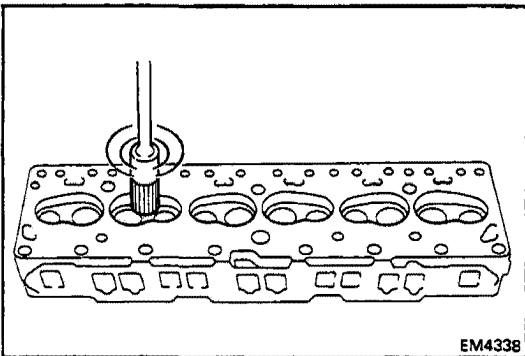

EM4338

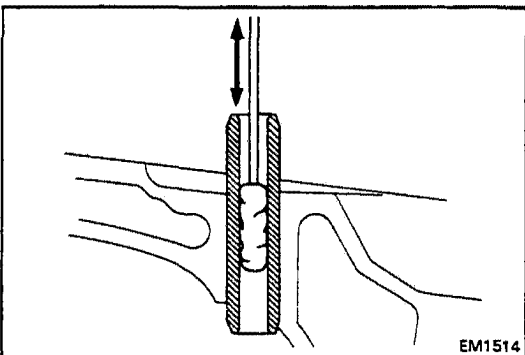

EM1514

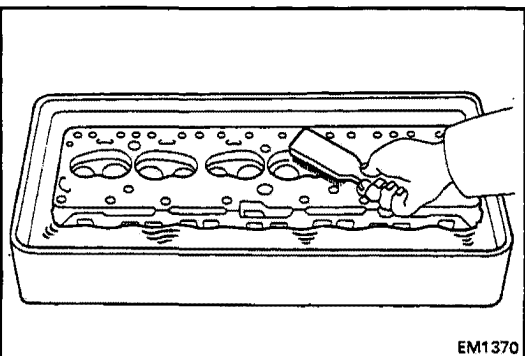

EM1370

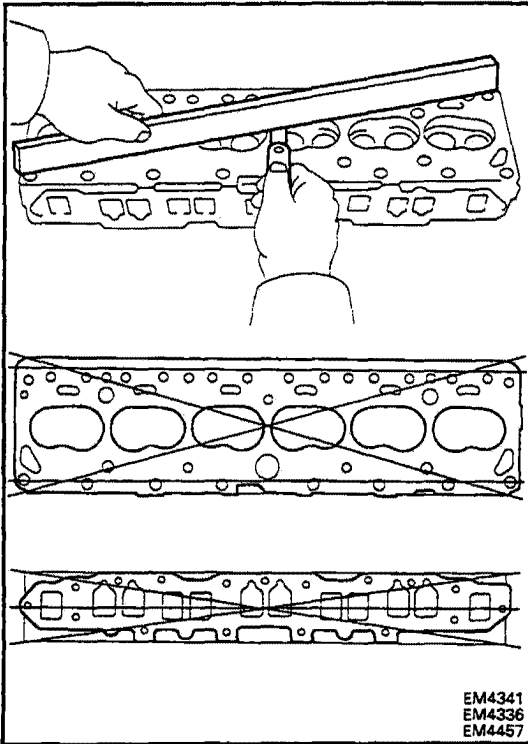

## 6. INSPECT CYLINDER HEAD FOR FLATNESS

Using a precision straight edge and thickness gauge, measure the surfaces contacting the cylinder block and manifolds for warpage.

**Maximum warpage:**

**Cylinder block side** 0.15 mm (0.0059 in.)

**Manifold side** 0.10 mm (0.0039 in.)

If warpage is greater than maximum, replace the cylinder head.

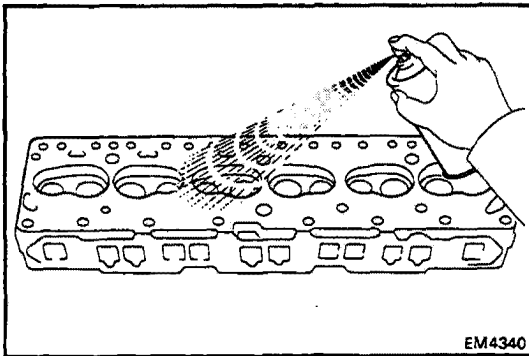

## 7. INSPECT CYLINDER HEAD FOR CRACKS

Using a dye penetrant, check the combustion chamber, intake and exhaust ports, head surface and the top of the head for cracks.

If cracked, replace the head.

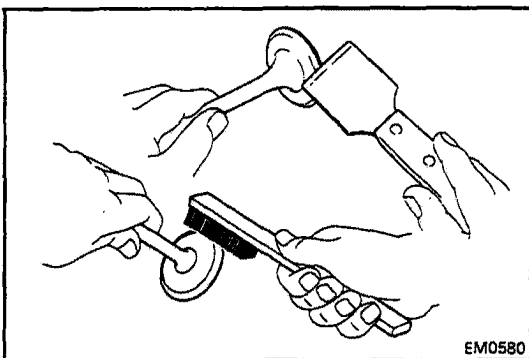

## 8. CLEAN VALVES

(a) Use a gasket scraper, chip any carbon from the valve head.

(b) Using a wire brush, thoroughly clean the valve.

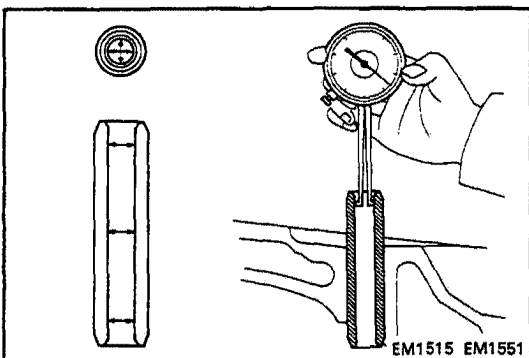

## 9. INSPECT VALVE STEM AND GUIDE BUSHINGS

(a) Using a caliper gauge, measure the inside diameter of the valve guide bushing.

**Guide bushing inside diameter:**

8.010 – 8.030 mm (0.3154 – 0.3161 in.)

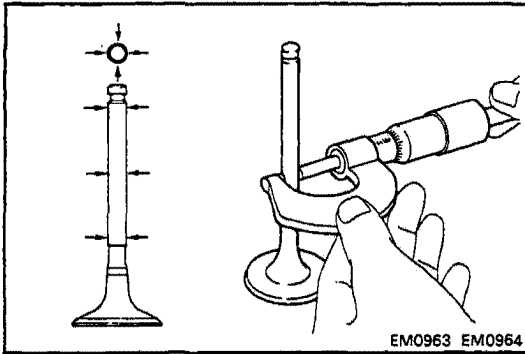

- (b) Using a micrometer, measure the diameter of the valve stem.

**Valve stem diameter:**

<b>Intake</b>	<b>7.970 – 7.985 mm</b> <b>(0.3138 – 0.3144 in.)</b>
<b>Exhaust</b>	<b>7.960 – 7.975 mm</b> <b>(0.3134 – 0.3140 in.)</b>

- (c) Subtract the valve stem diameter measurement from the valve guide bushing inside diameter measurement.

**Standard oil clearance:**

<b>Intake</b>	<b>0.025 – 0.060 mm</b> <b>(0.0010 – 0.0024 in.)</b>
<b>Exhaust</b>	<b>0.035 – 0.070 mm</b> <b>(0.0014 – 0.0028 in.)</b>

**Maximum oil clearance:**

<b>Intake</b>	<b>0.10 mm (0.0039 in.)</b>
<b>Exhaust</b>	<b>0.12 mm (0.0047 in.)</b>

If the clearance is greater than maximum, replace the valve and guide bushing.

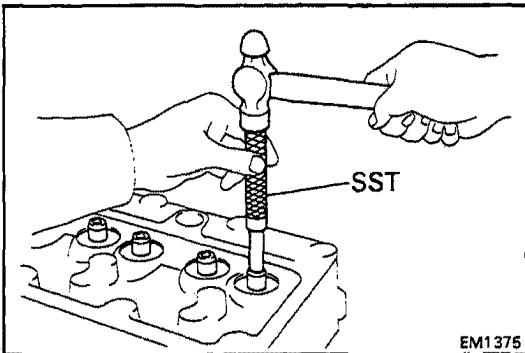

**10. IF NECESSARY, REPLACE VALVE GUIDE BUSHINGS**

- (a) Using SST and a hammer, drive out the valve guide bushing.

SST 09201-60011

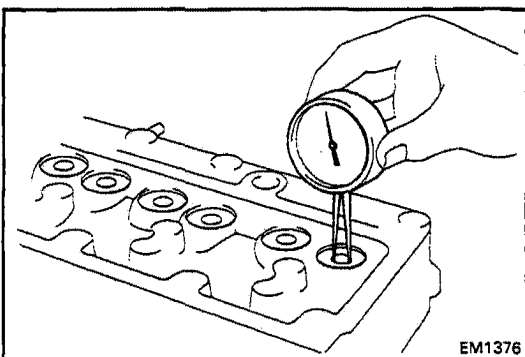

- (b) Using a caliper gauge, measure the bushing bore diameter of the cylinder head.

**Standard valve guide bore (cold):**

**14.000 – 14.018 mm (0.5512 – 0.5519 in.)**

If the bushing bore diameter of the cylinder head is more than 14.018 mm (0.5512 in.), machine the bore to the following dimensions and install an oversized bushing (O/S 0.05).

**Rebored cylinder head bushing bore dimensions:**

**14.050 – 14.068 mm (0.5531 – 0.5539 in.)**

If the bushing bore diameter of the cylinder head is greater than 14.068 mm (0.5539 in.), replace the cylinder head.

- (c) Using SST and a hammer, drive in a new valve guide bushing to where is 17.3 – 17.7 mm (0.681 – 0.697 in.) protruding from the cylinder head.

SST 09201-60011

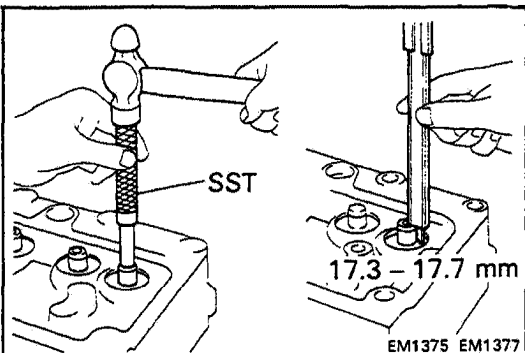

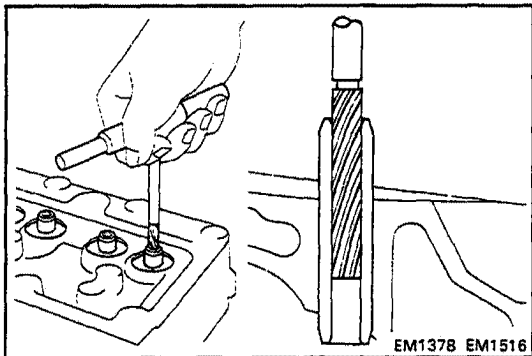
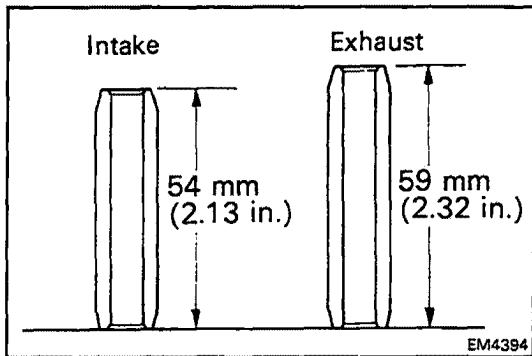

NOTE: Different bushings are used for the intake and exhaust.

(d) Using a sharp 8.0 mm reamer, ream the valve guide bushing to obtain the specified clearance between the valve guide bushing and the new valve.

**Intake clearance:** 0.025 – 0.060 mm (0.0010 – 0.0024 in.)  
**Exhaust clearance:** 0.035 – 0.070 mm (0.0014 – 0.0028 in.)

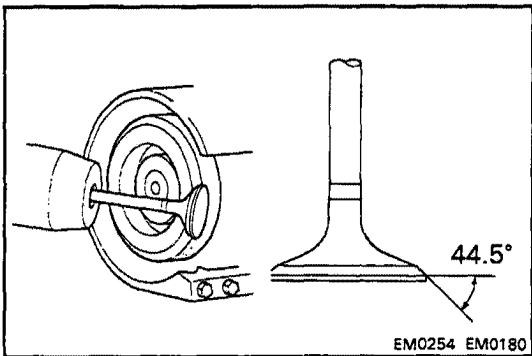

### 11. INSPECT AND GRIND VALVES

- (a) Grind the valve only enough to remove pits and carbon.
- (b) Check that the valve are ground to the correct valve face angle.

**Valve face angle:** 44.5°

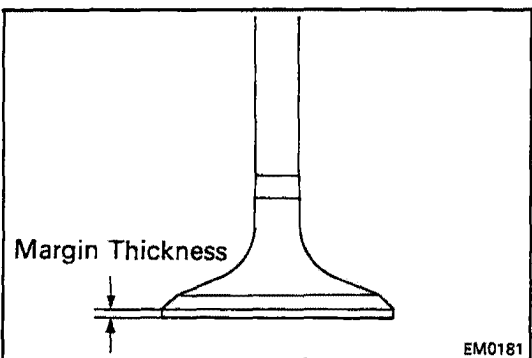

(c) Check the valve head margin thickness.

**Standard margin thickness:**  
 Intake 1.5 – 2.1 mm (0.059 – 0.083 in.)  
 Exhaust 1.7 – 2.3 mm (0.067 – 0.091 in.)  
**Minimum margin thickness:**  
 Intake 1.0 mm (0.039 in.)  
 Exhaust 1.2 mm (0.047 in.)

If the valve head margin thickness is less than minimum, replace the valve.

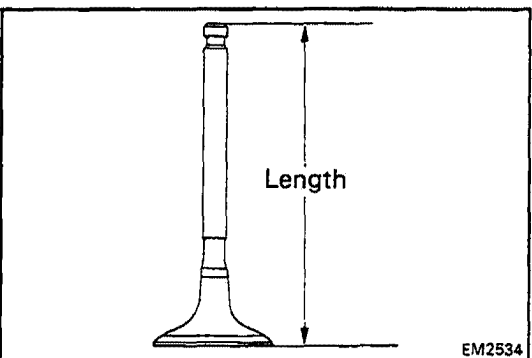

(d) Check the valve overall length.

**Standard overall length:**  
 Intake 124.8 mm (4.913 in.)  
 Exhaust 128.0 mm (5.039 in.)  
**Minimum overall length:**  
 Intake 124.3 mm (4.894 in.)  
 Exhaust 127.5 mm (5.020 in.)

If the valve overall length is less than minimum, replace the valve.

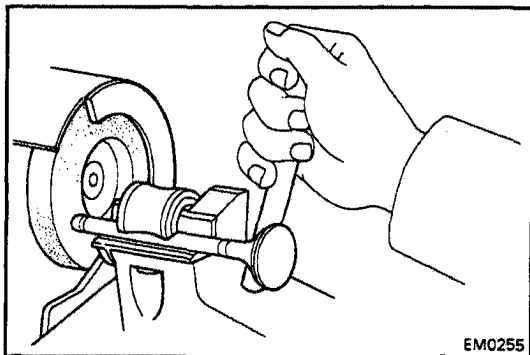

(e) Check the surface of the valve stem tip for wear. If the valve stem tip is worn, resurface the tip with a grinder or replace the valve.

**CAUTION:** Do not grind off more than the minimum overall length.

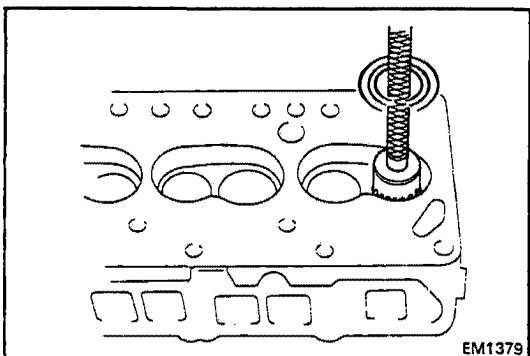

**12. INSPECT AND CLEAN VALVE SEATS**

(a) Using a 45° carbide cutter, resurface the valve seats. Remove only enough metal to clean the seats.

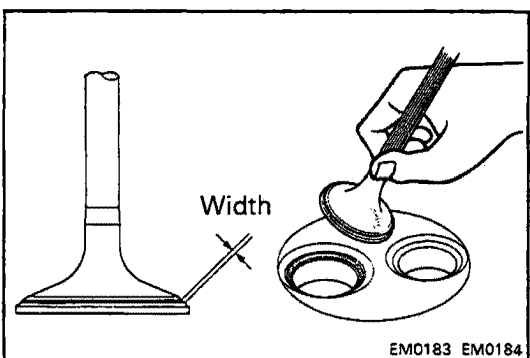

(b) Check the valve seating position. Apply a thin coat of prussian blue (or white lead) to the valve face. Install the valve. While applying light pressure to the valve, rotate the valve against the seat.

(c) Check the valve face and seat for the following:

- If blue appears 360° around the face, the valve is concentric. If not, replace the valve.
- If blue appears 360° around the valve seat, the guide and seat are concentric. If not, resurface the seat.

• Check that the seat contact is on the middle of the valve face with the following width:

**Intake 1.1 – 1.7 mm (0.043 – 0.067 in.)**  
**Exhaust 1.4 – 2.0 mm (0.055 – 0.079 in.)**

If not, correct the valve seat as follows:

(1) (Intake)  
 If the seating is too high on the valve face, use 25° (IN) and 45° cutters to correct the seat.

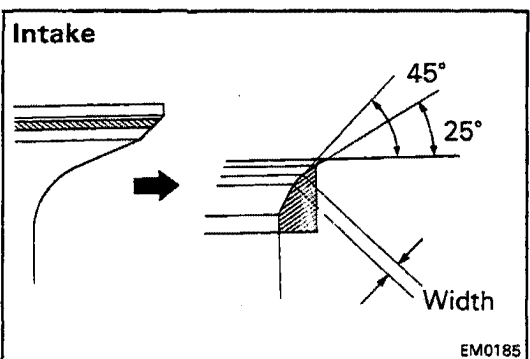

(2) If the seating is too low on the valve face, use 70° (IN) or 65° (EX) and 45° cutters to correct the seat.

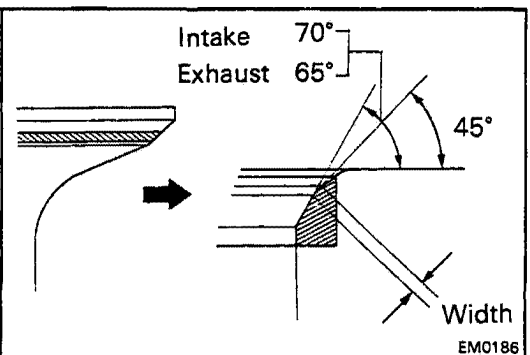

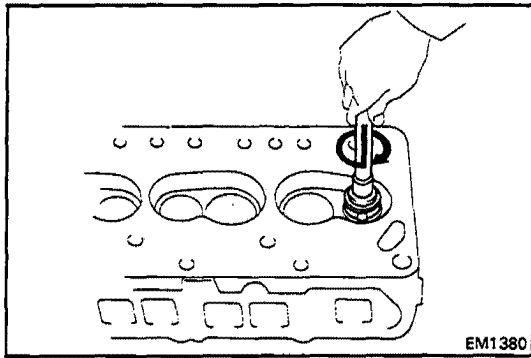

- (d) Hand-lap the valve and valve seat with an abrasive compound.
- (e) After hand-lapping, lean the valve and valve seat.

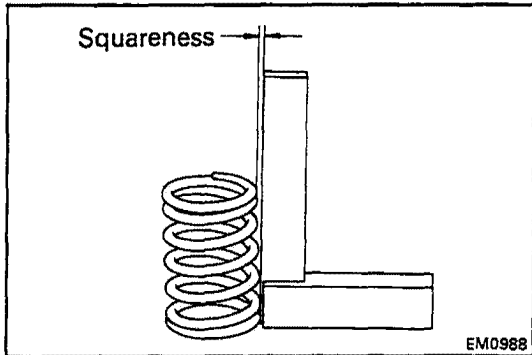

### 13. INSPECT VALVE SPRINGS

- (a) Using a steel square, measure the squareness of the valve spring.

**Maximum squareness: 1.8 mm (0.071 in.)**

If squareness is greater than maximum, replace the valve spring.

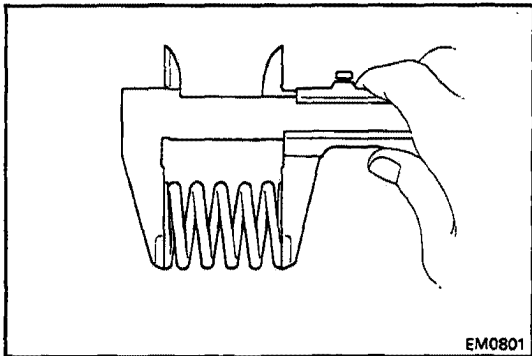

- (b) Using calipers, measure the free length of the valve spring.

**Standard free length: 51.5 mm (2.028 in.)**

**Minimum free Length: 50.0 mm (1.967 in.)**

If the length is less than minimum, replace the valve.

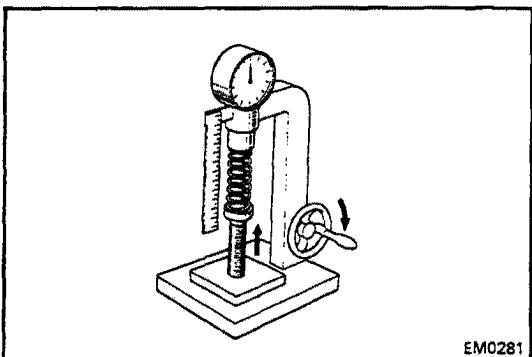

- (c) Using a spring tester, measure the tension of the valve spring at the specified installed length.

**Standard installed tension:**

**32.5 kg (71.6 lb, 319 N) at 43.0 mm (1.693 in.)**

**Minimum installed tension:**

**27 kg (59.5 lb, 265 N) at 43.0 mm (1.693 in.)**

If the installed tension is less than minimum, replace the valve spring.

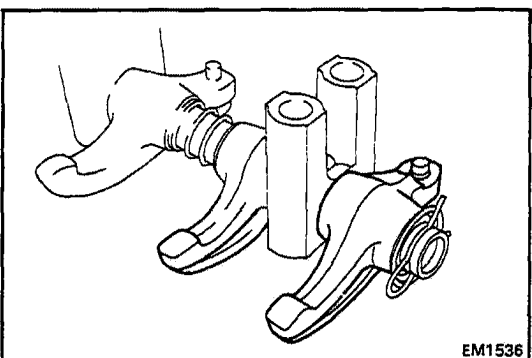

### 14. INSPECT ROCKER ARM AND SHAFT

- (a) Inspect the valve contacting surface of the rocker arm for wear.

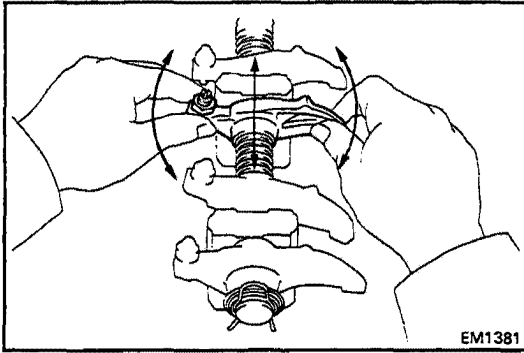

(b) Inspect the rocker arm-to-shaft clearance by moving each rocker arm as shown in the figure.

If movement is felt, disassemble and inspect.

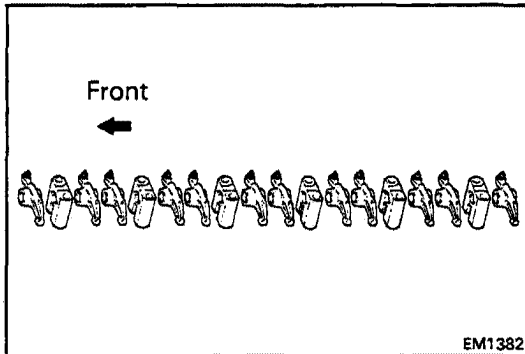

(c) Disassemble the valve rocker shaft assembly.

NOTE: Arrange the rocker arms and rocker supports in correct order.

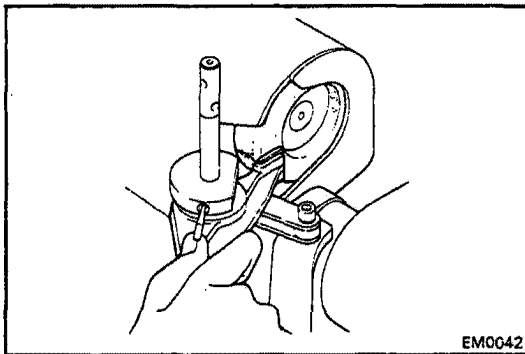

If the contacting surface of the rocker arm is worn, resurface it a valve refacer and oil stone or replace the rocker arm.

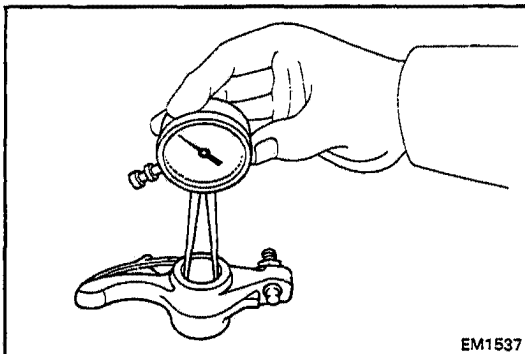

(d) Inspect the oil clearance between the rocker arm and shaft.

- Using a caliper gauge, measure the inside diameter of the rocker arm.

**Rocker arm inside diameter:**

**18.494 – 18.515 mm (0.7281 – 0.7289 in.)**

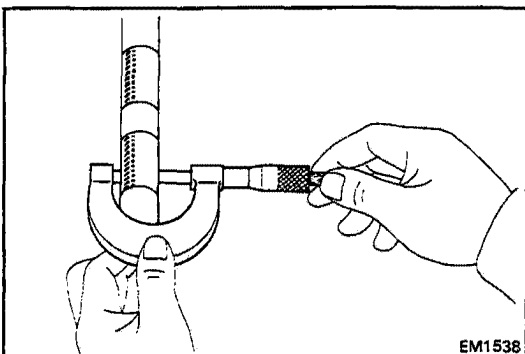

- Using a micrometer, measure the diameter of the rocker shaft.

**Rocker shaft diameter:**

**18.464 – 18.485 mm (0.7269 – 0.7278 in.)**

- Subtract the rocker shaft diameter measurement from the inside diameter measurement of the rocker arm.

**Standard oil clearance:** 0.009 – 0.051 mm  
(0.0004 – 0.0020 in.)

**Maximum oil clearance:** 0.08 mm (0.0031 in.)

If the clearance is greater than maximum, replace the rocker arm and shaft.

(e) Assemble the valve rocker shaft assembly as shown.

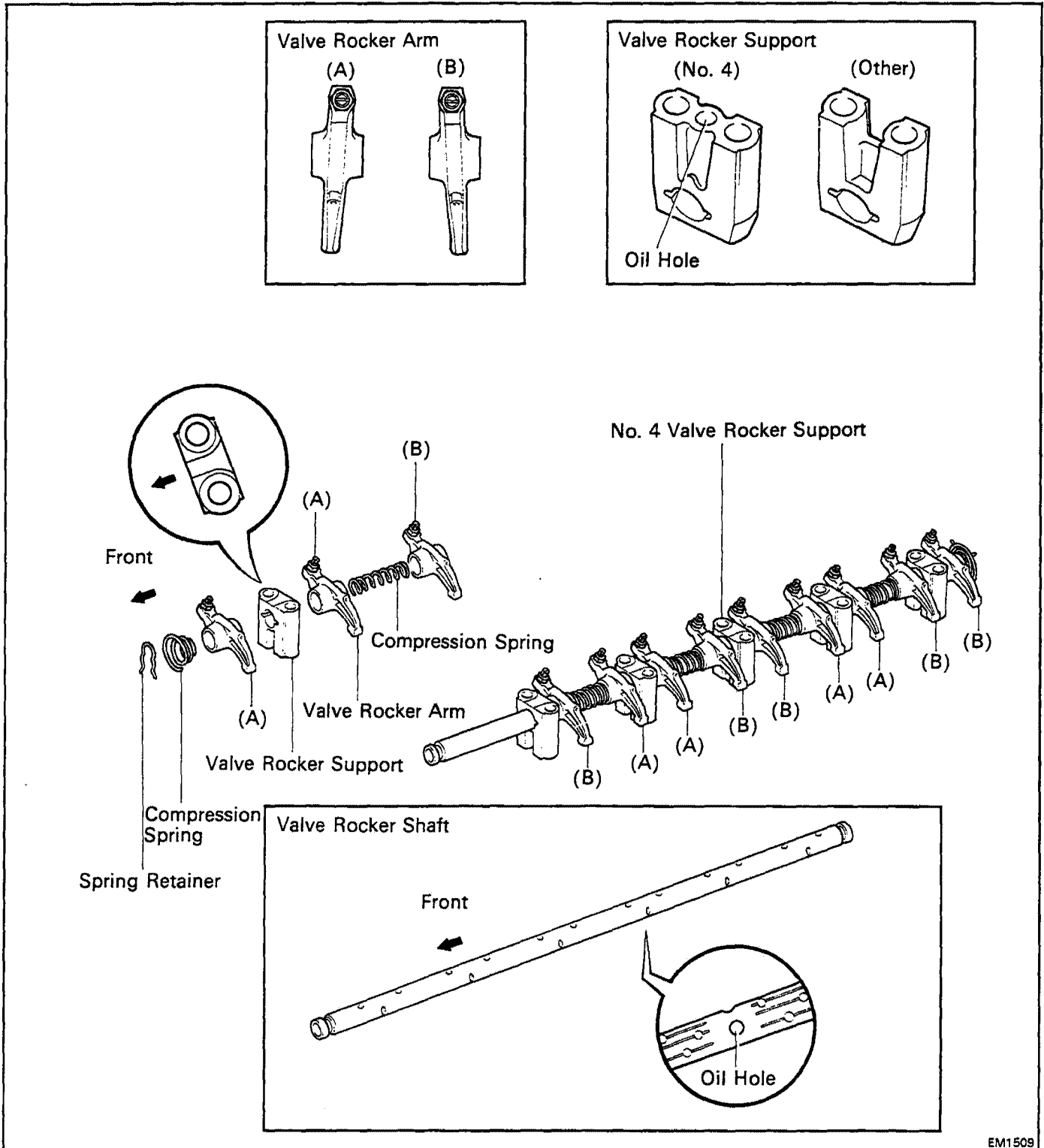

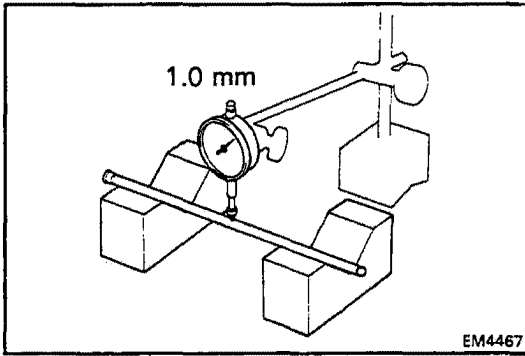

### 15. INSPECT PUSH RODS

- Place the push rod on V-blocks.
- Using a dial indicator, measure the circle runout at the center of the push rod.

**Maximum circle runout: 1.0 mm (0.039 in.)**

If the circle runout is greater than maximum, replace the push rod.

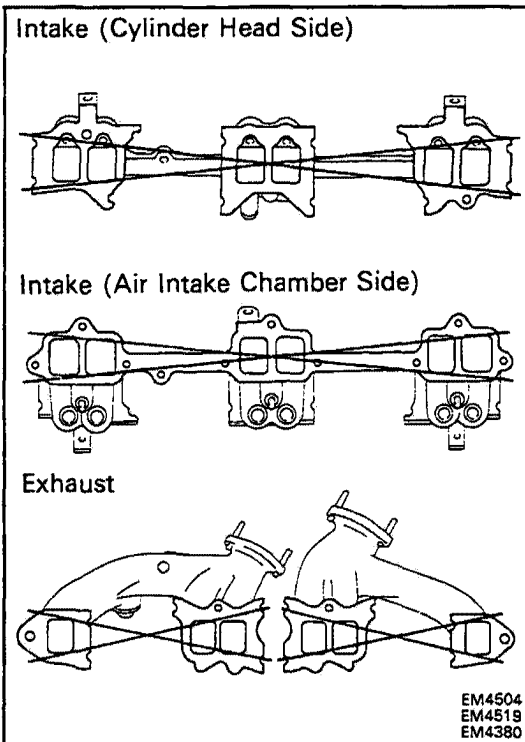

### 16. INSPECT INTAKE AND EXHAUST MANIFOLDS

Using a precision straight edge and thickness gauge, measure the surfaces contacting the cylinder head and air intake chamber for warpage.

**Maximum warpage: 0.50 mm (0.0197 in.)**

If the warpage is greater than maximum, replace the manifold.

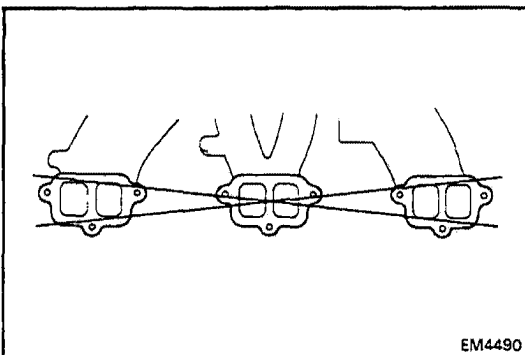

### 17. INSPECT AIR INTAKE CHAMBER

Using a precision straight edge and thickness gauge, measure the surfaces contacting the intake manifold for warpage.

**Maximum warpage: 0.2 mm (0.008 in.)**

If the warpage is greater than maximum, replace the air intake chamber.

## ASSEMBLY OF CYLINDER HEAD

(See page EM-11)

### NOTE:

- Thoroughly clean all parts to be assembled.
- Before installing the parts, apply new engine oil to all sliding and rotating surfaces.
- Replace all gaskets and oil seals with new ones.

### 1. INSTALL VALVES

- (a) Place the valve spring seat on spring seat.

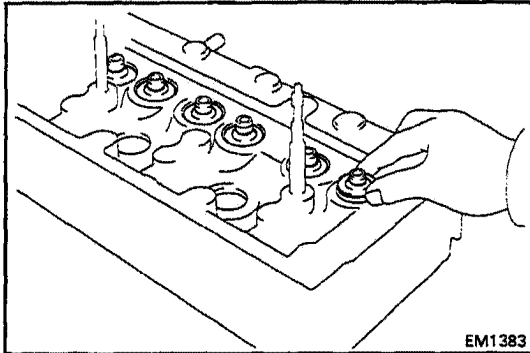

- (b) Using SST and a hammer, tap in a new oil seal.  
SST 09201-31010

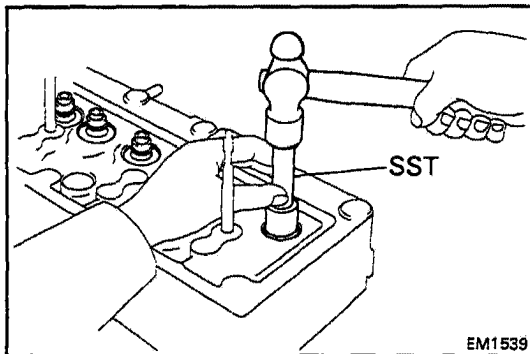

- (c) Install the valve, spring and spring retainer (or valve rotator).

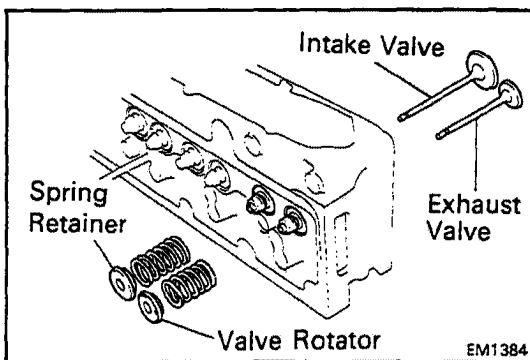

- NOTE: Install the spring with the correct direction as shown.

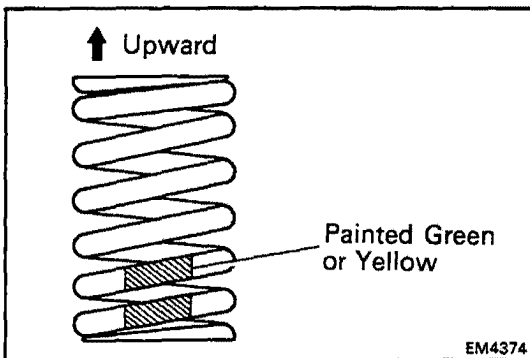

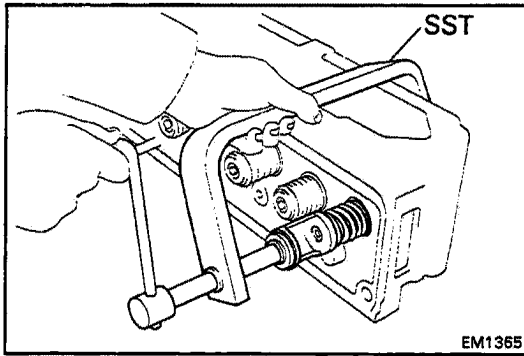

(d) Using SST, compress the valve spring and place the two keepers around the valve stem.

SST 09202-43013

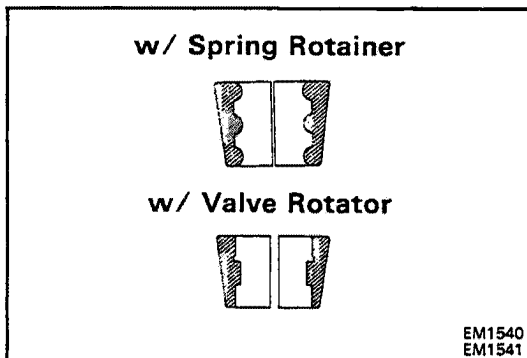

NOTE: Different keepers are used for the spring retainer and valve rotator.

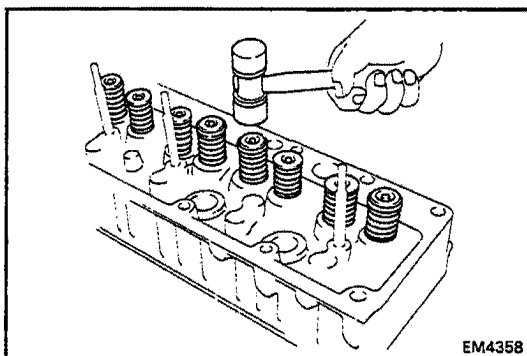

(e) Using a plastic-faced hammer, lightly tap the valve stem tip to assure proper fit.

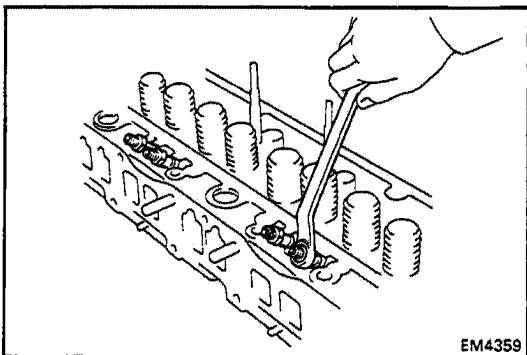

**2. INSTALL AIR INJECTION MANIFOLD UNIONS**

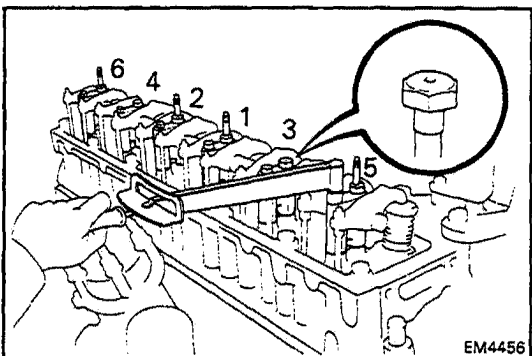
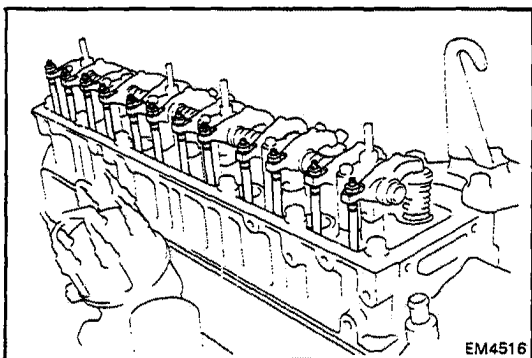
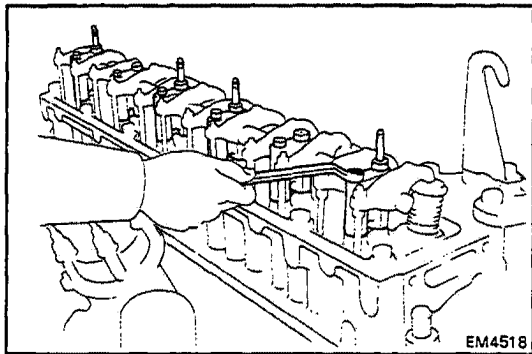
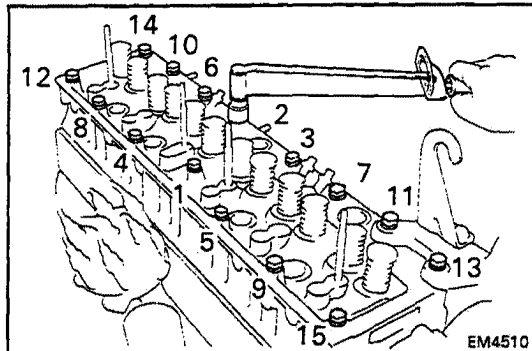
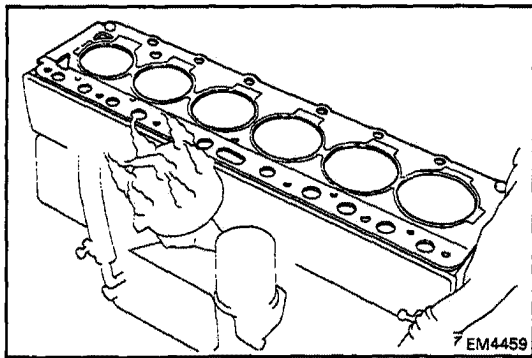

## INSTALLATION OF CYLINDER HEAD

(See page EM-11)

### 1. INSTALL CYLINDER HEAD

- (a) Place a new cylinder head gasket on the cylinder block.

**CAUTION:** Be careful of the installation direction.

- (b) Place the cylinder head on the cylinder head gasket.

- (c) Apply a light coat of engine oil on the threads and under the cylinder head bolts.

- (d) Install and uniformly tighten the ten cylinder head bolts with the plate washers in several passes, in the sequence shown.

**Torque:** 1,250 kg-cm (90 ft-lb, 123 N-m)

### 2. INSTALL PUSH RODS

Install the twelve push rods.

### 3. INSTALL VALVE ROCKER SHAFT ASSEMBLY

- (a) Place the rocker shaft assembly on the cylinder head.

- (b) Align the rocker arm adjusting screws with the heads of the push rods.

- (c) Install and uniformly tighten the eight bolts and four nuts in several passes, in the sequence shown.

**Torque:**

12 mm bolt head

240 kg-cm (17 ft-lb, 24 N-m)

14 mm bolt head and nut

340 kg-cm (25 ft-lb, 33 N-m)

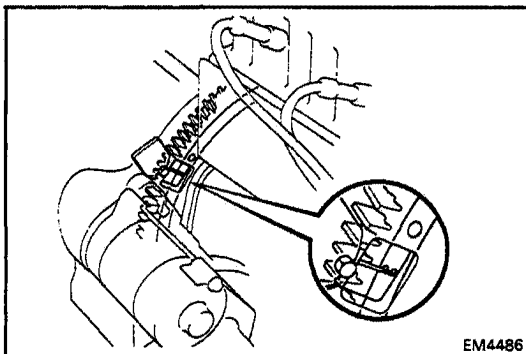

EM4486

**4. ADJUST VALVE CLEARANCE**

(a) Set the No. 1 cylinder to TDC/compression.

- Align the TDC mark of the drive plate with the timing pointer by turning the crankshaft clockwise with a wrench.
- Check that the rocker arms on the No. 1 cylinder are loose and rocker arms on the No. 6 are tight.

If not, turn the crankshaft one revolution (360°) and align the mark as above.

(b) Adjust only those valves indicated by arrows.

**Valve clearance:**

**Intake 0.20 mm (0.008 in.)**

**Exhaust 0.35 mm (0.014 in.)**

NOTE: After warm up, readjust the valve clearance.

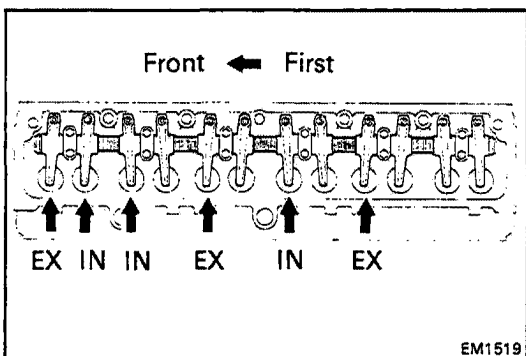

EM1519

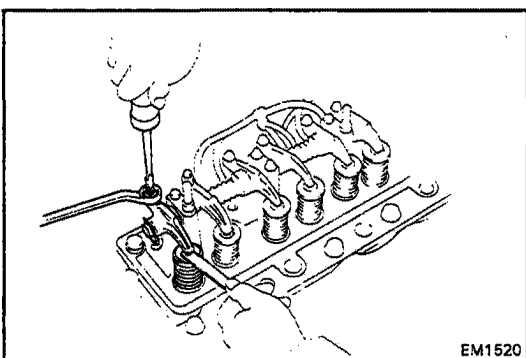

EM1520

- Using a thickness gauge, measure the valve clearance between the valve stem and rocker arm. Loosen the lock nut and turn the adjusting screw to set the proper clearance. Hold the adjusting screw in position and tighten the lock nut.
- Recheck the valve clearance. The thickness gauge should slide with a very slight drag.

(c) Turn the crankshaft pulley one revolution (360°) and align the mark as above. Adjust only the valves indicated by arrows.

**5. INSTALL SPARK PLUGS**

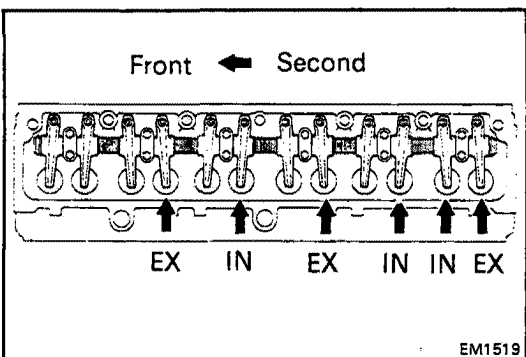

EM1519

**6. INSTALL CYLINDER HEAD COVER**

- (a) Install a new gasket to the cylinder head cover.
- (b) Install the cylinder head cover with four seal washer and cap nuts.

**Torque: 90 kg-cm (78 in.-lb, 8.8 N·m)**

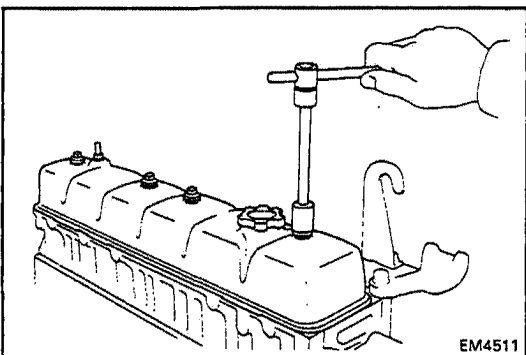

EM4511

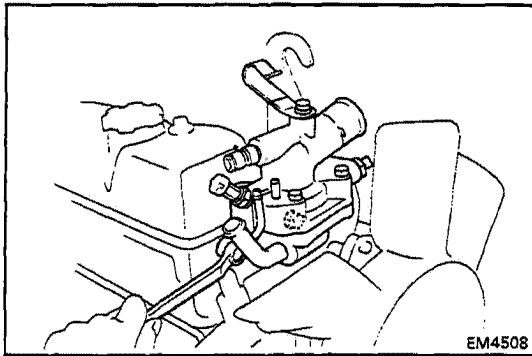

EM4508

## 7. INSTALL WATER OUTLET ASSEMBLY

- (a) Install a new gasket and the water outlet assembly with the two bolts.

**Torque: 250 kg-cm (18 ft-lb, 25 N·m)**

- (b) Connect the water by-pass hose.

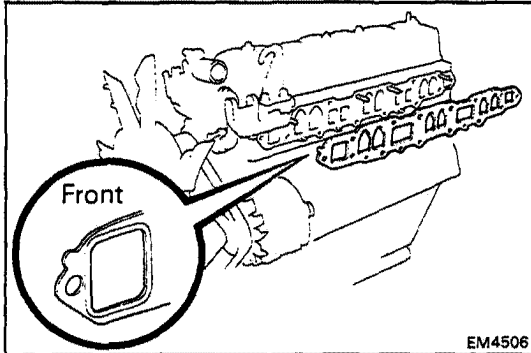

EM4506

## 8. INSTALL INTAKE AND EXHAUST MANIFOLDS

- (a) Place a new gasket so that the front mark is toward the front side.

- (b) Install the intake manifold and exhaust manifolds with the ten bolts, four plate washers and nuts. Torque the bolts and nuts.

**Torque:**

**17 mm bolt (A) 700 kg-cm (51 ft-lb, 69 N·m)**

**14 mm bolt (B) 510 kg-cm (37 ft-lb, 50 N·m)**

**Nut (C) 570 kg-cm (41 ft-lb, 56 N·m)**

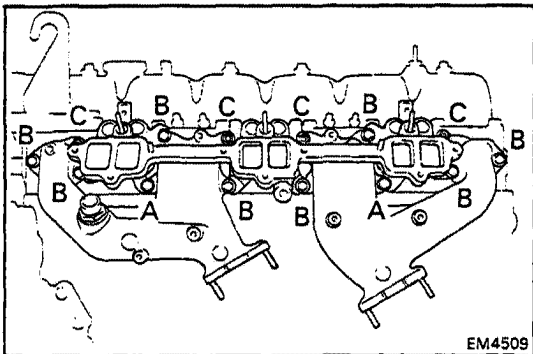

EM4509

- (c) Install the three manifold heat insulators with the six bolts.

**Torque: 120 kg-cm (9 ft-lb, 12 N·m)**

- (d) Install the manifold stay with the two bolts.

**Torque: 300 kg-cm (22 ft-lb, 29 N·m)**

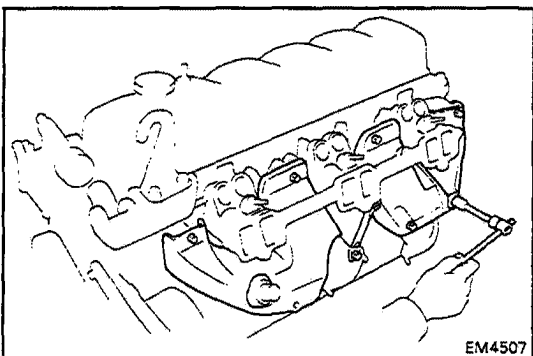

EM4507

## 9. INSTALL AIR INJECTION MANIFOLD

Install the air injection manifold with the four union nuts and two clamp bolts.

**Torque: 210 kg-cm (15 ft-lb, 21 N·m)**

## 10. INSTALL INJECTORS AND DELIVERY PIPE

(See steps 1 to 6 on pages FI-61 to 63)

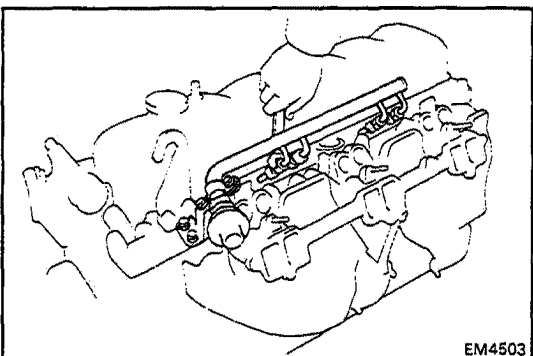

EM4503

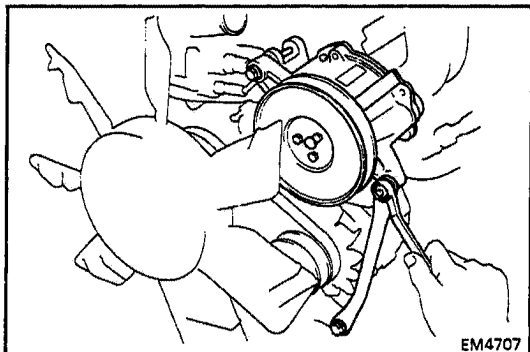
**11. INSTALL AIR PUMP**

- (a) Install the air pump with the through bolt and nut.
- (b) Install the air pump stay with the bolt and nut.
- (c) Connect the air hose.

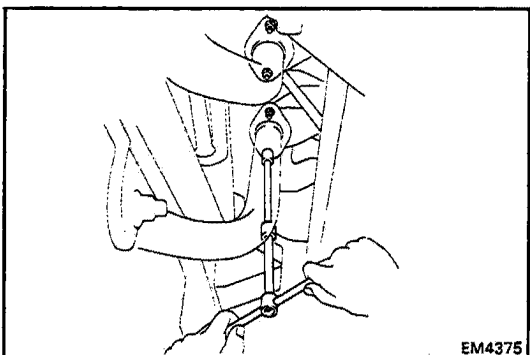
**12. RAISE VEHICLE**

**CAUTION:** Be sure the vehicle is securely supported.

**13. CONNECT EXHAUST PIPE TO EXHAUST MANIFOLD**

- (a) Place two new gasket on the exhaust pipe.
- (b) Connect the exhaust pipe with four new nuts. Torque the nuts.

**Torque:** 630 kg-cm (46 ft-lb, 62 N·m)

**14. CONNECT FUEL HOSES****15. CONNECT RADIATOR UPPER HOSE****16. INSTALL HEATER WATER (OIL COOLER) PIPE**

- (a) Install the heater water (oil cooler) pipe with the bolts.
- (b) Connect the hoses to the water outlet, water pump, oil cooler and heater water pipe.

**17. CONNECT HIGH-TENSION CORDS TO SPARK PLUGS AND IGNITION COIL****18. INSTALL PS PUMP AND A/C COMPRESSOR BRACKETS****19. INSTALL A/C COMPRESSOR**

- (a) Install the A/C compressor with the four bolts.
- (b) Install and adjust the drive belt. (See page MA-4)

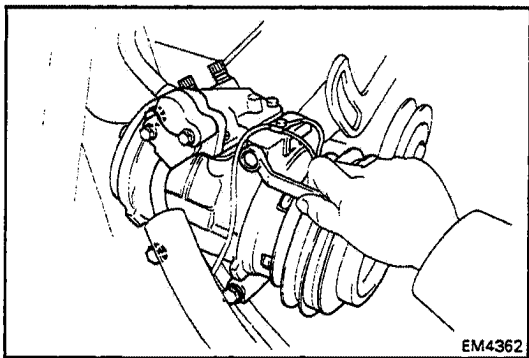
**20. INSTALL PS PUMP**

- (a) Install the PS pump with the two bolts. Do not tighten the bolts.
- (b) Install the woodruff key, drive pulley with the plate washer spring washer and mount nut.
- (c) Install and adjust drive belt (See page MA-4)
- (d) Push on the drive belt to hold the pulley in place and torque the pulley nut.

**Torque:** 480 kg-cm (35 ft-lb, 47 N·m)

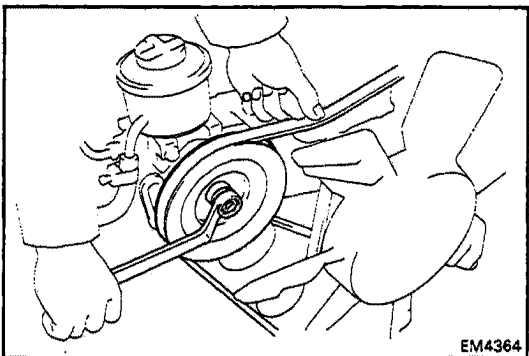

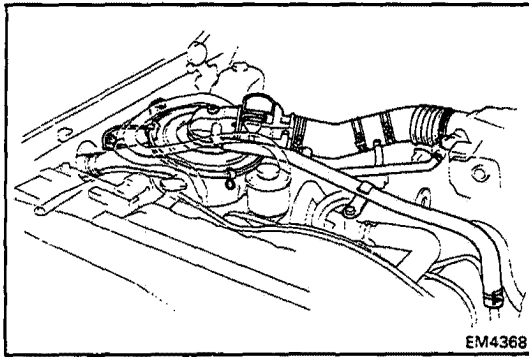

## 21. INSTALL AIR INTAKE HOSE, AIR FLOW METER AND AIR CLEANER CAP

- (a) Install the air intake hose, air flow meter and air cleaner cap with the wing nut and three clips.
- (b) Connect following hoses:
  - ISC hose
  - Air pump hose
  - Distributor hose
  - PCV hose
  - Three hoses from the intake chamber rear side
  - Two hoses from the VCV of the charcoal canister

## 22. CONNECT ACCELERATOR AND THROTTLE CABLES, AND ADJUST THEM

## 23. FILL WITH ENGINE COOLANT (See page CO-3)

### Capacity:

- w/ Front heater  
17.5 liters (18.5 US qts, 15.4 Imp. qts)
- w/ Front and rear heaters  
19.5 liters (20.6 US qts, 17.2 Imp. qts)

## 24. CONNECT CABLE TO NEGATIVE TERMINAL OF BATTERY

## 25. START ENGINE AND CHECK FOR LEAKS

## 26. PERFORM ENGINE ADJUSTMENT

- (a) Adjust the ignition timing.  
(See steps 10 to 14 on page IG-11)

Ignition timing: 7° BTDC @ idle  
(w/ Terminals TE1 and E1 short-circuited)

- (b) Adjust the valve clearance. (See page EM-7)

### Valve clearance (Hot):

- Intake 0.20 mm (0.008 in.)
- Exhaust 0.35 mm (0.014 in.)

## 27. INSTALL HOOD

## 28. PERFORM ROAD TEST

Check for abnormal noise, shock, slippage and smooth operation.

## 29. RECHECK ENGINE COOLANT LEVEL AND OIL LEVEL

# TIMING GEARS AND CAMSHAFT COMPONENTS

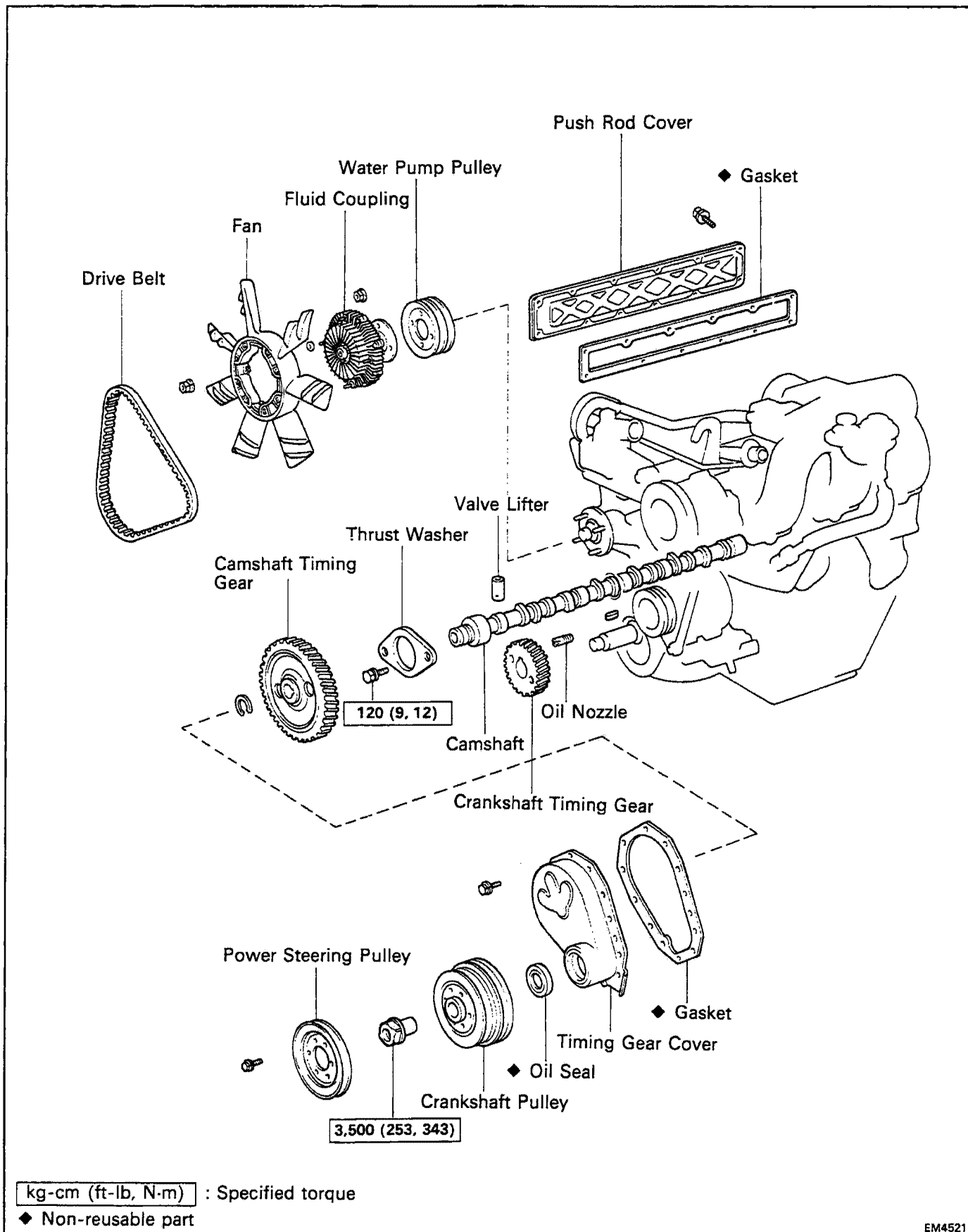

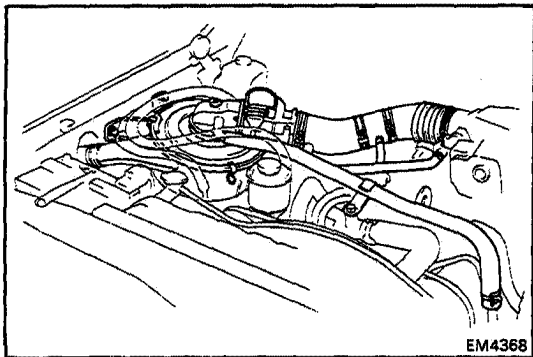
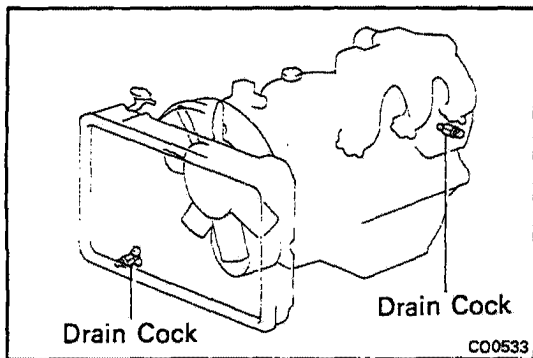

## REMOVAL OF TIMING GEARS AND CAMSHAFT

(See page EM-33)

1. **DRAIN ENGINE COOLANT**  
(See page CO-3)
2. **DISCONNECT ACCELERATOR AND THROTTLE CABLES**
3. **REMOVE AIR INTAKE HOSE, AIR FLOW METER AND AIR CLEANER ASSEMBLY**
  - (a) Disconnect the air flow meter connector and clamp.
  - (b) Disconnect following hoses:
    - ISC hose
    - Air pump hose
    - Distributor hose
    - PCV hose
    - Three hoses from the intake chamber rear side
    - Two hoses from the VCV of the charcoal canister
  - (c) Loosen the air intake hose clamp.
  - (d) Remove the wing nut and loosen the three clips, and remove the air intake hose, air flow meter and air cleaner cap.
4. **LOOSEN PS DRIVE PULLEY NUT**  
Push on the drive belt to hold the pulley in place and loosen the pulley nut.
5. **REMOVE FLUID COUPLING WITH FAN AND WATER PUMP PULLEY**  
(See steps 2 to 6 on pages CO-4, 5)
6. **REMOVE PS PUMP AND A/C COMPRESSOR**  
(See steps 6 and 7 on page EM-12)
7. **REMOVE PS AND A/C COMPRESSOR BRACKETS**
8. **REMOVE PS IDLER PULLEY AND BRACKET ASSEMBLY**
9. **REMOVE DISTRIBUTOR**
10. **REMOVE VALVE ROCKER SHAFT ASSEMBLY**  
(See steps 21 to 23 on pages EM-14, 15)
11. **REMOVE PUSH ROD COVER**  
Remove the ten bolts, two nuts, push rod cover and gasket.

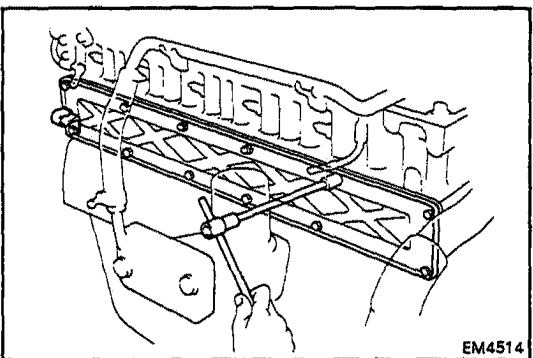

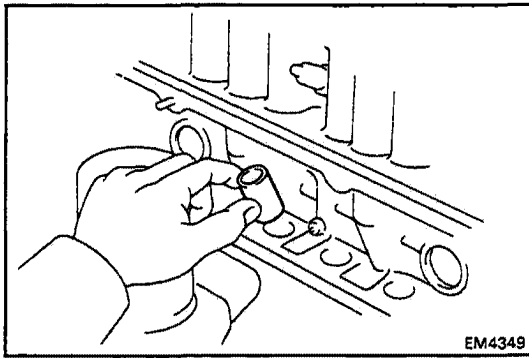

**12. REMOVE VALVE LIFTERS**

Remove the twelve valve lifters in order, beginning from the No.1 valve lifters.

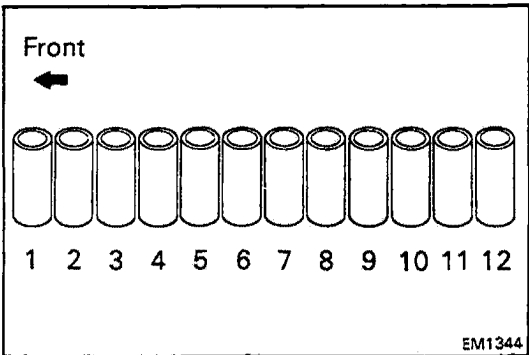

**NOTE:** Arrange the valve lifters in correct order.

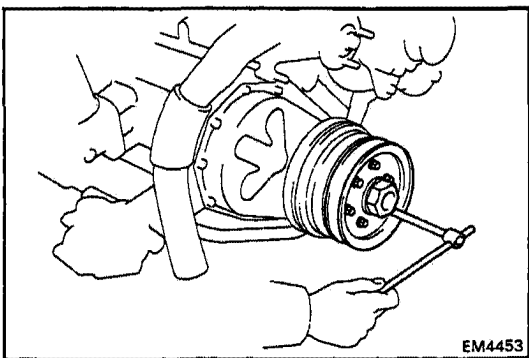

**13. REMOVE PS PULLEY FROM CRANKSHAFT PULLEY**

Remove the six bolts and PS pulley.

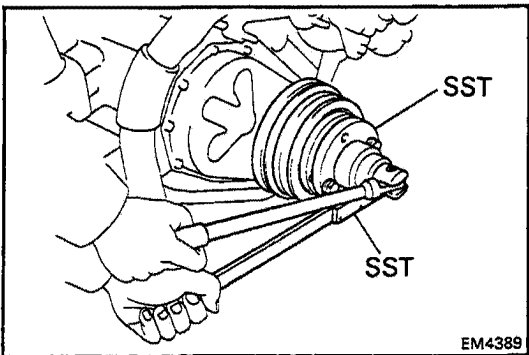

**14. REMOVE CRANKSHAFT PULLEY**

(a) Using SST and a 46 mm socket wrench, remove the pulley mount bolt.

SST 09213-58011 and 09330-00020

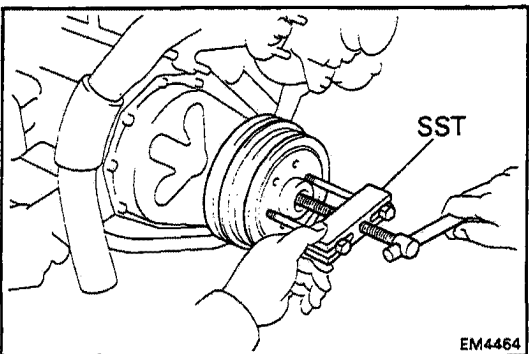

(b) Using SST, remove the pulley.

SST 09213-60017

**15. REMOVE OIL COOLER PIPE WITH HOSE**

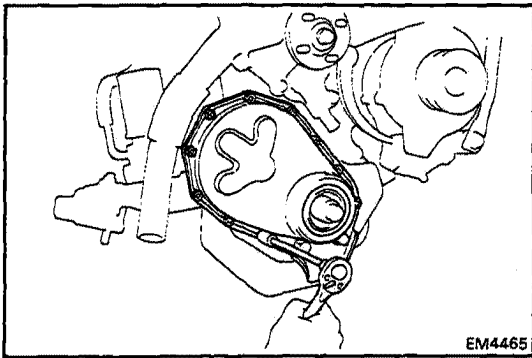
**16. REMOVE TIMING GEAR COVER**

Remove the twelve bolts, gear cover and gasket.

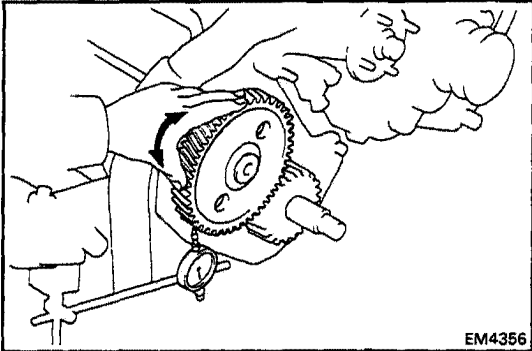
**17. CHECK TIMING GEAR BACKLASH**

Using a dial indicator, measure the backlash at several places while turning the camshaft clockwise and counterclockwise.

**Standard backlash:** 0.100 – 0.183 mm  
(0.0039 – 0.0072 in.)

**Maximum backlash:** 0.25 mm (0.0098 in.)

If the backlash is greater than maximum, replace the camshaft and crankshaft timing gears.

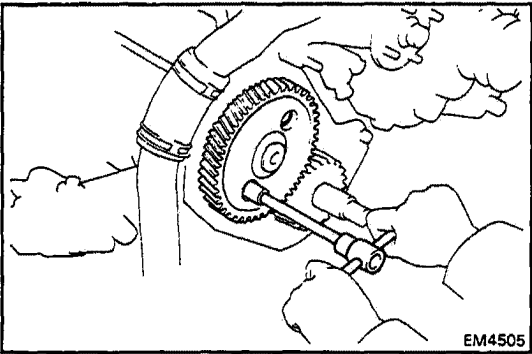
**18. REMOVE CAMSHAFT TIMING GEAR AND CAMSHAFT ASSEMBLY**

(a) Remove the two bolts mounting the thrust plate to the cylinder block.

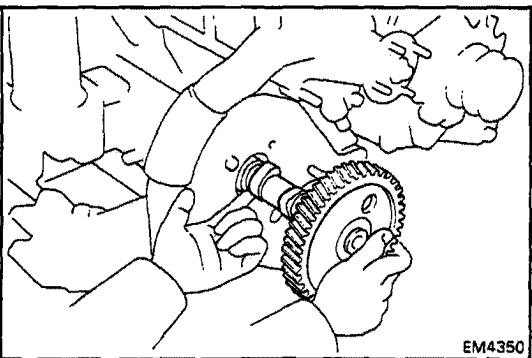

(b) Carefully pull out the camshaft and timing gear assembly.

**CAUTION:** Be careful not to damage the camshaft bearing.

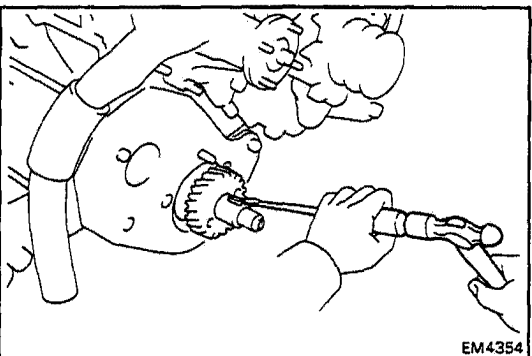
**19. REMOVE CRANKSHAFT TIMING GEAR**

(a) Using a screwdriver and hammer, tap out the crankshaft pulley set key.

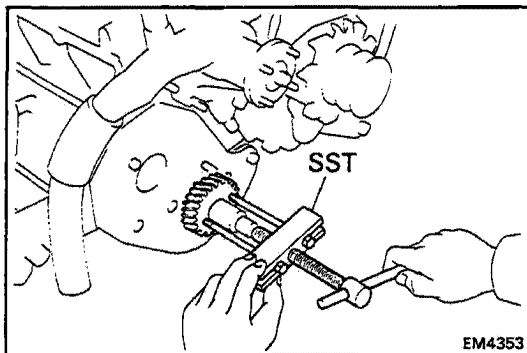

- (b) Using SST, remove the timing gear.  
SST 09213-60017

## 20. IF NECESSARY, REMOVE OIL NOZZLE

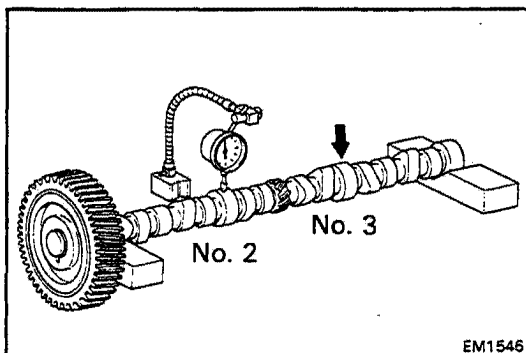

## INSPECTION OF TIMING GEARS AND CAMSHAFT

### INSPECT CAMSHAFT

- (a) Place the camshaft on V-blocks and, using a dial indicator, measure the circle runout at the No. 2 and No.3 journals.

**Maximum circle runout: 0.30 mm (0.0118 in.)**

If the circle runout is greater than maximum, replace the camshaft.

- (b) Using a micrometer, measure the cam lobe height.

**Standard cam lobe height:**

<b>Intake</b>	<b>38.36 – 38.46 mm</b> <b>(1.5102 – 1.5142 in.)</b>
<b>Exhaust</b>	<b>38.25 – 38.35 mm</b> <b>(1.5059 – 1.5098 in.)</b>

**Minimum cam lobe height:**

<b>Intake</b>	<b>38.0 mm (1.496 in.)</b>
<b>Exhaust</b>	<b>37.9 mm (1.492 in.)</b>

If the lobe height is less than minimum, replace the camshaft.

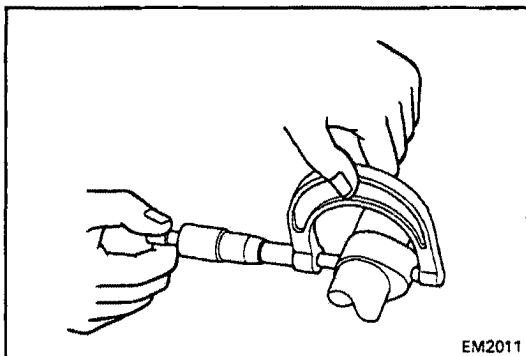

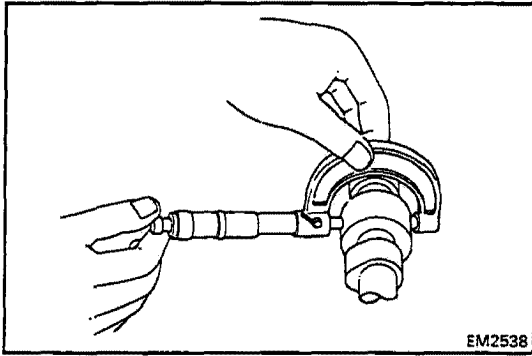

(c) Using a micrometer, measure the the journal diameter.

**Journal diameter (from front side):**

<b>STD size</b>	<b>No. 1</b>	<b>47.955 – 47.975 mm</b> <b>(1.8880 – 1.8888 in.)</b>
	<b>No. 2</b>	<b>46.455 – 46.475 mm</b> <b>(1.8289 – 1.8297 in.)</b>
	<b>No. 3</b>	<b>44.955 – 44.975 mm</b> <b>(1.7699 – 1.7707 in.)</b>
	<b>No. 4</b>	<b>43.455 – 43.475 mm</b> <b>(1.7108 – 1.7116 in.)</b>
<b>U/S 0.25</b>	<b>No. 1</b>	<b>47.715 – 47.725 mm</b> <b>(1.8785 – 1.8789 in.)</b>
	<b>No. 2</b>	<b>46.215 – 46.225 mm</b> <b>(1.8195 – 1.8199 in.)</b>
	<b>No. 3</b>	<b>44.715 – 44.725 mm</b> <b>(1.7604 – 1.7608 in.)</b>
	<b>No. 4</b>	<b>43.215 – 43.225 mm</b> <b>(1.7014 – 1.7018 in.)</b>
<b>U/S 0.50</b>	<b>No. 1</b>	<b>47.465 – 47.475 mm</b> <b>(1.8687 – 1.8691 in.)</b>
	<b>No. 2</b>	<b>45.965 – 45.975 mm</b> <b>(1.8096 – 1.8888 in.)</b>
	<b>No. 3</b>	<b>44.465 – 44.475 mm</b> <b>(1.7506 – 1.7510 in.)</b>
	<b>No. 4</b>	<b>42.965 – 42.975 mm</b> <b>(1.6915 – 1.6919 in.)</b>

If the journal diameter is not within specification, check the oil clearance. (See page EM-65)

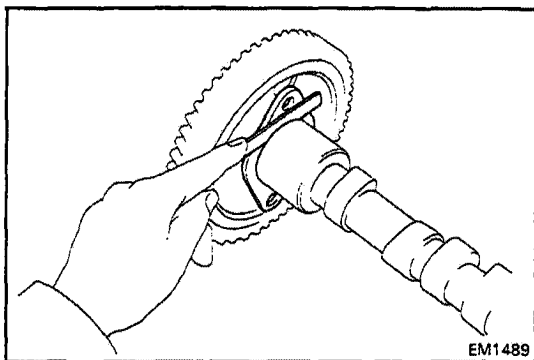

(d) Using a thickness gauge, measure the thrust clearance between the thrust plate and camshaft.

**Standard thrust clearance: 0.200 – 0.290 mm**  
**(0.0079 – 0.0114 in.)**

**Maximum thrust clearance: 0.33 mm (0.0130 in.)**

If the clearance is greater than maximum, replace the thrust plate. If necessary, replace the camshaft.

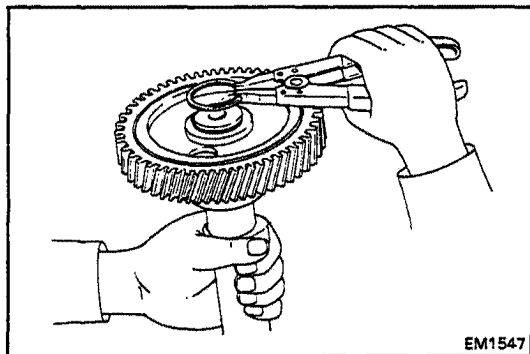

## DISASSEMBLY AND ASSEMBLY OF CAMSHAFT AND CAMSHAFT TIMING GEAR

### 1. DISASSEMBLE CAMSHAFT AND CAMSHAFT TIMING GEAR

(a) Using snap ring pliers, remove the snap ring.

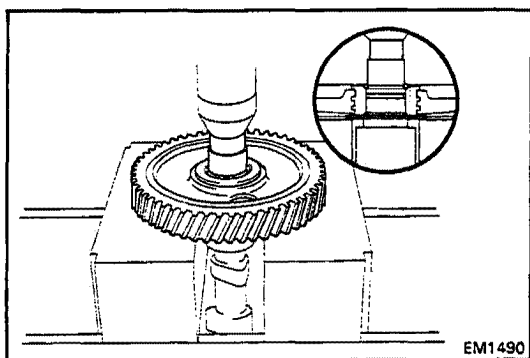

(b) Using a socket wrench and press, press out camshaft.

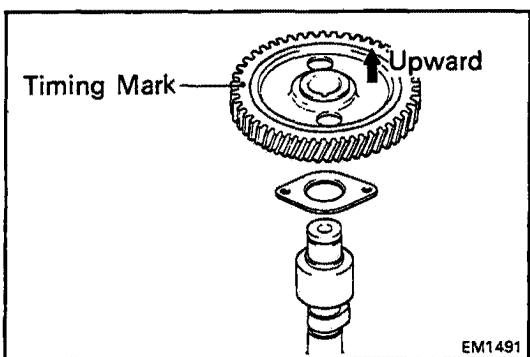

### 2. ASSEMBLE CAMSHAFT AND CAMSHAFT TIMING GEAR

(a) Install the timing gear set key to the camshaft.

(b) Assemble the camshaft, thrust plate and timing gear as shown.

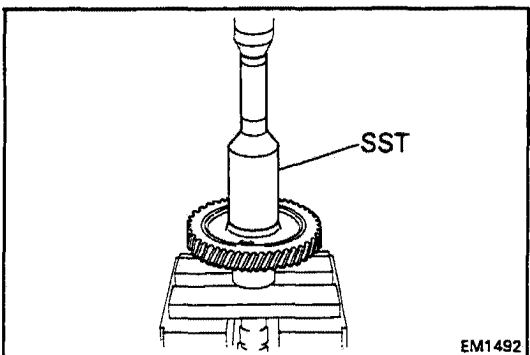

(c) Using SST and a press, align the timing gear set key with the key groove of the timing gear, and press in the camshaft.

SST 09214-60010

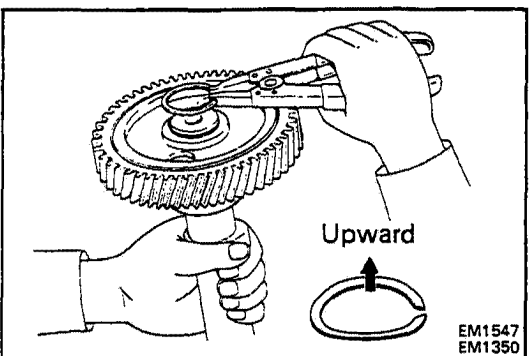

(d) Using snap ring pliers, install the snap ring as shown.

### 3. CHECK CAMSHAFT THRUST CLEARANCE (See page EM-38)

Thrust clearance: **0.200 – 0.290 mm**  
(**0.0079 – 0.0114 in.**)

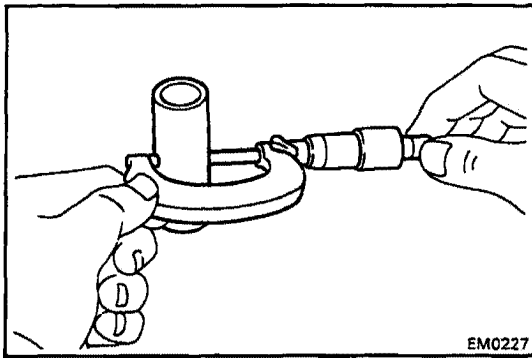

## INSPECTION OF VALVE LIFTERS

### INSPECT VALVE LIFTERS

Using a micrometer, measure the valve lifter diameter.

Lifter diameter:

STD size 21.387 – 21.404 mm  
(0.8420 – 0.8427 in.)

O/S 0.05 21.437 – 21.454 mm  
(0.8440 – 0.8446 in.)

If the diameter is not within specification, check the oil clearance. (See page EM-67)

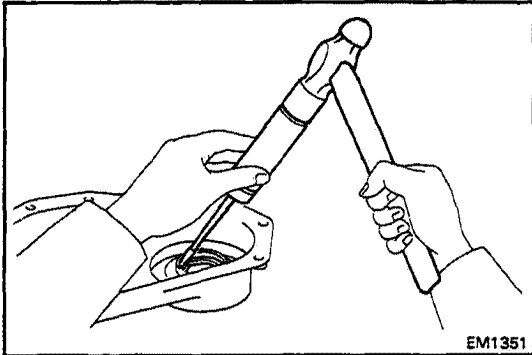

## REPLACEMENT OF CRANKSHAFT FRONT OIL SEAL

### REPLACE CRANKSHAFT FRONT OIL SEAL

NOTE: There are two methods (A and B) to replace the oil seal as follows.

#### A. If timing gear cover is removed from cylinder block:

(a) Using a screwdriver and hammer, tap out the oil seal.

(b) Using SST and a hammer, tap in a new oil seal.

SST 09223-50010

(c) Apply MP grease to the oil seal.

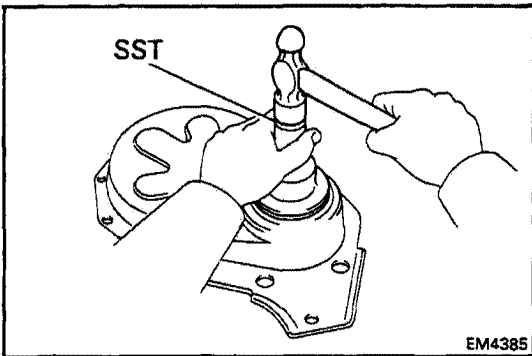

#### B. If timing gear cover is installed to cylinder block:

(a) Using SST, remove the oil seal.

SST 09308-10010

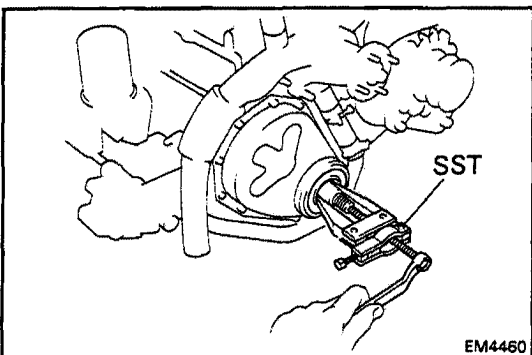

(b) Apply MP grease to a new oil seal lip.

(c) Using SST and a hammer tap in the oil seal.

SST 09238-47012

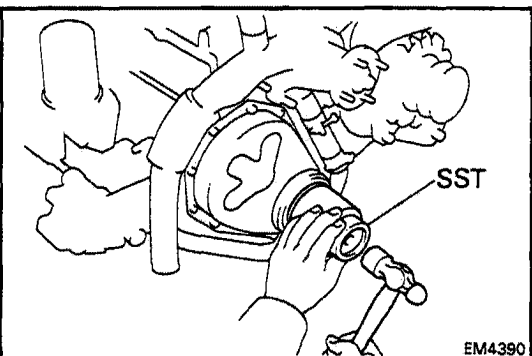

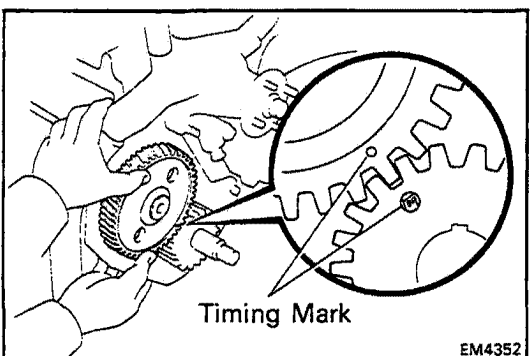
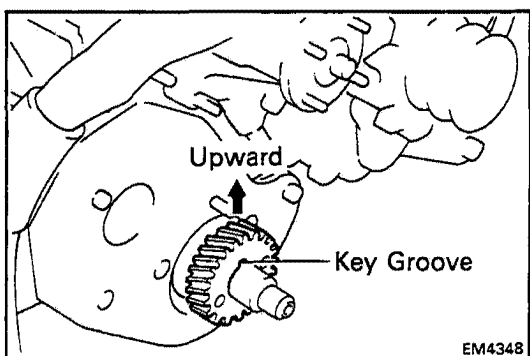
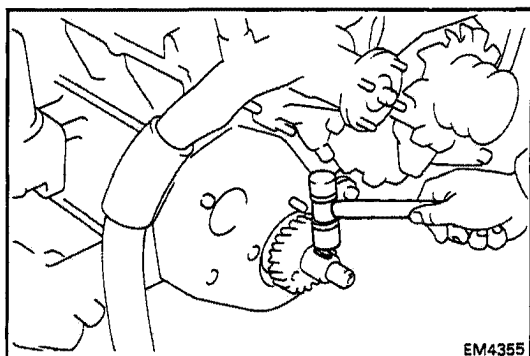
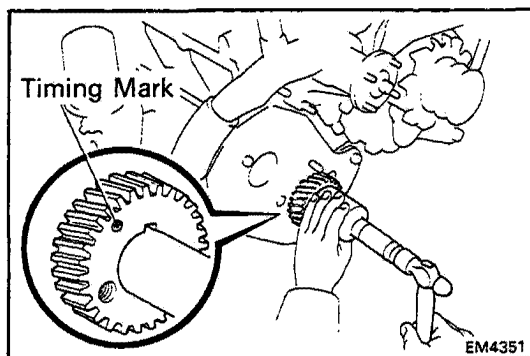

## INSTALLATION OF TIMING GEARS AND CAMSHAFT

(See page EM-33)

### 1. INSTALL CRANKSHAFT TIMING GEAR

- (a) Put the timing gear on the crankshaft with timing mark facing forward.
- (b) Align the timing gear set key with the key groove of the timing gear.
- (c) Using SST and a hammer, tap in the timing gear.  
SST 09214-60010
- (d) Using a plastic-faced hammer, tap in the crankshaft pulley set key.

### 2. INSTALL CAMSHAFT TIMING GEAR AND CAMSHAFT ASSEMBLY

- (a) Set the crankshaft timing gear with the key groove facing upward by turning the crankshaft clockwise.

- (b) Insert the camshaft into the cylinder block.

**CAUTION:** Be careful not to damage the camshaft bearings.

- (c) Align the timing marks of the crankshaft and camshaft timing gears and mesh the gears.

**NOTE:** At this time, No 6 cylinder should be at TDC / compression.

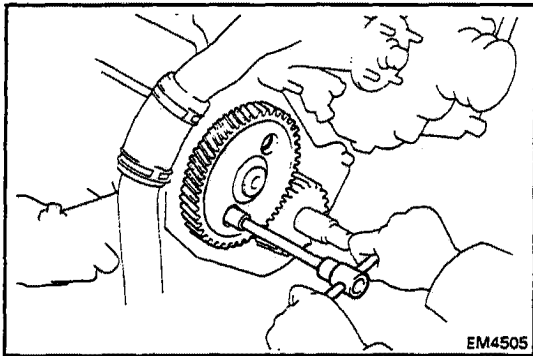

(d) Install the two bolts mounting the thrust washer to the cylinder block. Torque the bolts.

**Torque: 120 kg-cm (9 ft-lb, 12 N-m)**

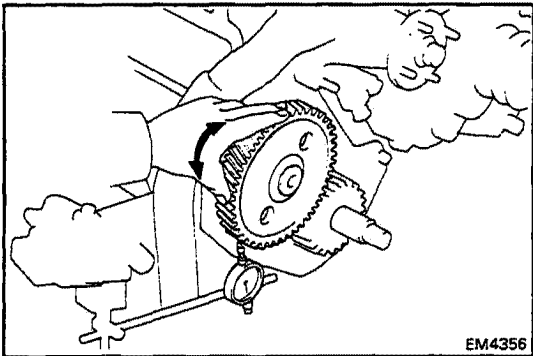

**3. CHECK TIMING GEAR BACKLASH**

Using a dial indicator, measure the backlash at several places while turning the camshaft clockwise and counterclockwise.

**Standard backlash: 0.100 – 0.183 mm  
(0.0039 – 0.0072 in.)**

**Maximum backlash: 0.25 mm (0.0098 in.)**

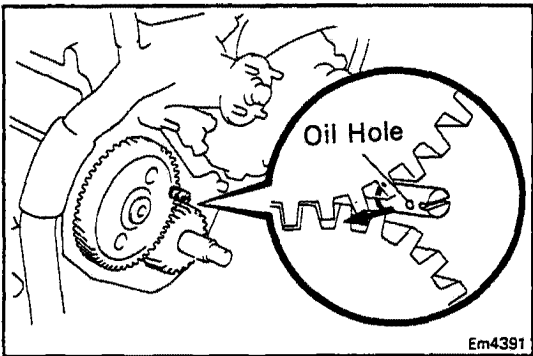

**4. INSTALL OIL NOZZLE**

(a) Install and set the oil nozzle in position.

(b) Using a chisel and hammer, stake the threads of the oil nozzle.

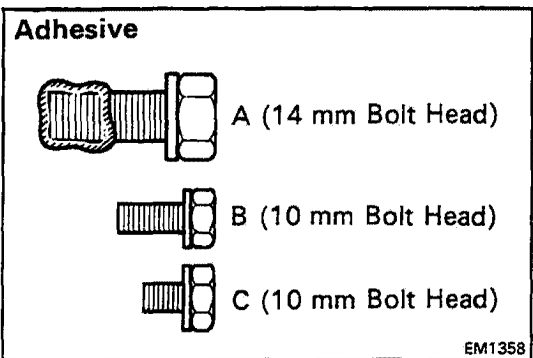

**5. INSTALL TIMING GEAR COVER AND CRANKSHAFT PULLEY**

**NOTE:** There are three size timing gear cover bolts indicated A, B and C.

(a) Apply adhesive to the threads of the two A bolts.

**Adhesive: Part No. 08833-00080, THREE BOND 1344, LOCTITE 242 or equivalent.**

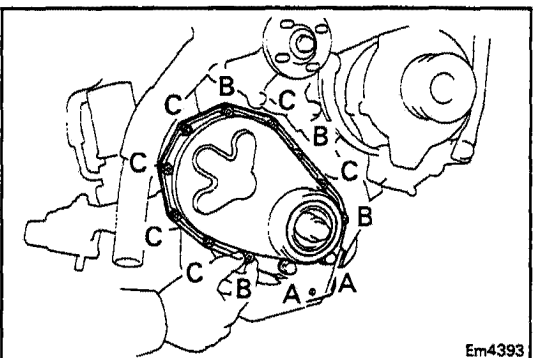

(b) Install a new gasket and the gear cover with the twelve bolts. Finger tighten all bolts.

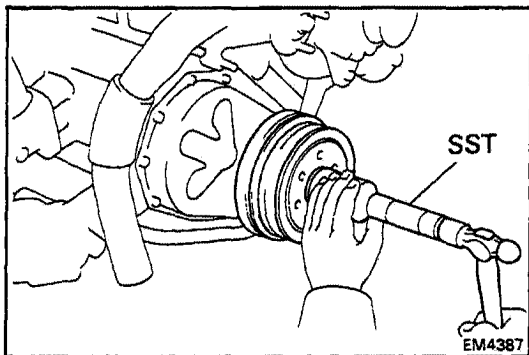

(c) Align the pulley set key with the key groove of the pulley.

(d) Using SST and a hammer, tap in the pulley.

SST 09214-60010

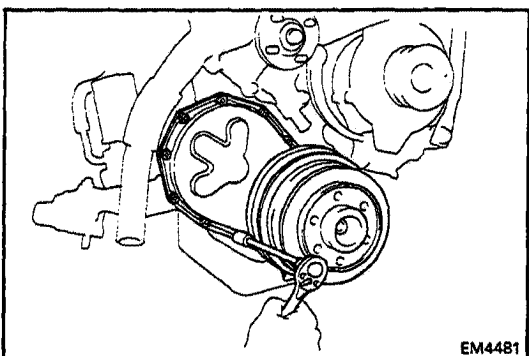

(e) After installed the pulley, torque the cover bolts.

**Torque:**

**Bolts A**                    **250 kg-cm (18 ft-lb, 25 N·m)**

**Bolts B and C**        **50 kg-cm (43 in-lb, 4.9 N·m)**

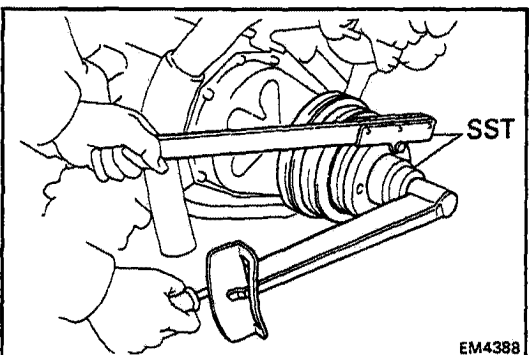

(f) Using SST and a 46-mm socket wrench, install and torque the pulley mount bolt.

SST 09213-58011 and 09330-00020

**Torque: 3,500 kg-cm (253 ft-lb, 343 N·m)**

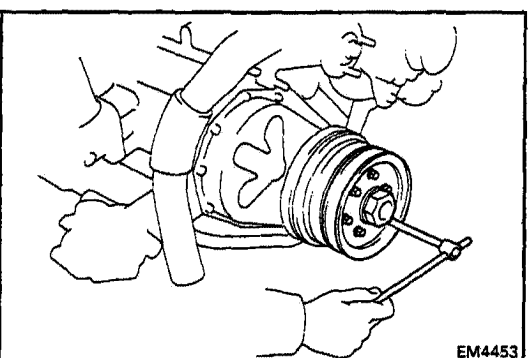

**6. INSTALL PS PULLEY TO CRANKSHAFT PULLEY**

Install the PS pulley with the six bolts. torque the bolts.

**Torque: 185 kg-cm (13ft-lb, 18 N·m)**

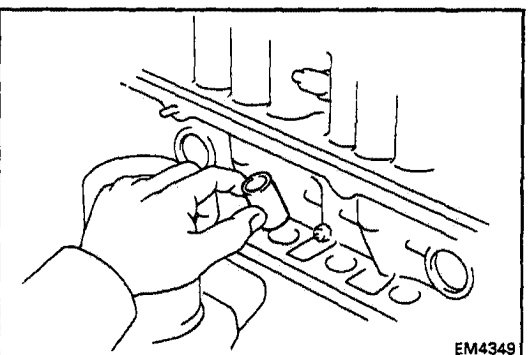

**7. INSTALL VALVE LIFTERS**

Carefully insert the twelve lifters into the lifter bore.

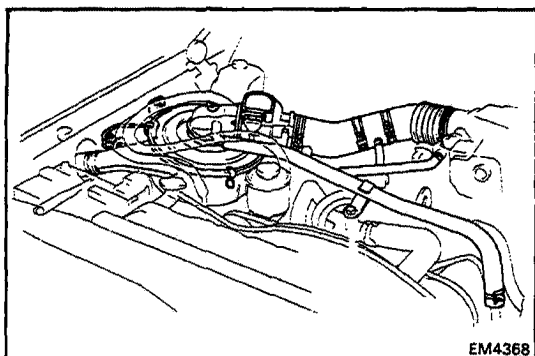
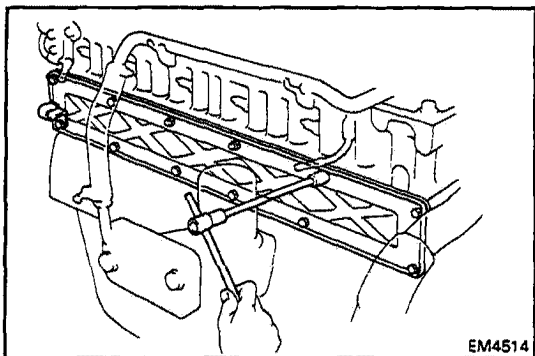
**8. INSTALL PUSH ROD COVER**

Install a new gasket and the push rod cover with the ten bolts and two nuts.

Torque: 40 kg-cm (35 in.-lb, 3.9 N-m)

**9. INSTALL VALVE ROCKER SHAFT ASSEMBLY**  
(See steps 2 to 4 on pages EM-28, 29)**10. INSTALL DISTRIBUTOR** (See page IG-10)**11. INSTALL WATER PUMP PULLEY AND FLUID COUPLING WITH FAN** (See page CO-7)**12. INSTALL PS IDLER PULLEY AND BRACKET ASSEMBLY****13. INSTALL PS AND A/C COMPRESSOR BRACKETS****14. INSTALL PS PUMP AND A/C COMPRESSOR**  
(See steps 19 and 20 on page EM-31)**15. INSTALL AIR INTAKE HOSE, AIR FLOW METER AND AIR CLEANER ASSEMBLY**

(a) Install the air intake hose, air flow meter and air cleaner cap with the wing nut and three clips.

(b) Connect following hoses:

- ISC hose
- Air pump hose
- Distributor hose
- PCV hose
- Three hoses from the intake chamber rear side
- Two hoses from the VCV of the charcoal canister

**16. CONNECT ACCELERATOR AND THROTTLE CABLES, AND ADJUST THEM****17. FILL WITH ENGINE COOLANT** (See page CO-3)**18. CONNECT CABLE TO NEGATIVE TERMINAL OF BATTERY****19. START ENGINE AND CHECK FOR LEAKS****20. PERFORM ENGINE ADJUSTMENT**

(a) Adjust the ignition timing.  
(See steps 10 to 14 on page IG-11)

Ignition timing: 7° BTDC @ idle  
(w/ Terminals TE1 and E1 short-circuited)

(b) Adjust the valve clearance. (See page EM-7)

Valve clearance (Hot):

Intake	0.20 mm (0.008 in.)
Exhaust	0.35 mm (0.014 in.)

**21. PERFORM ROAD TEST**

Check for abnormal noise, shock, slippage and smooth operation.

**22. RECHECK ENGINE COOLANT LEVEL**

# CYLINDER BLOCK COMPONENTS

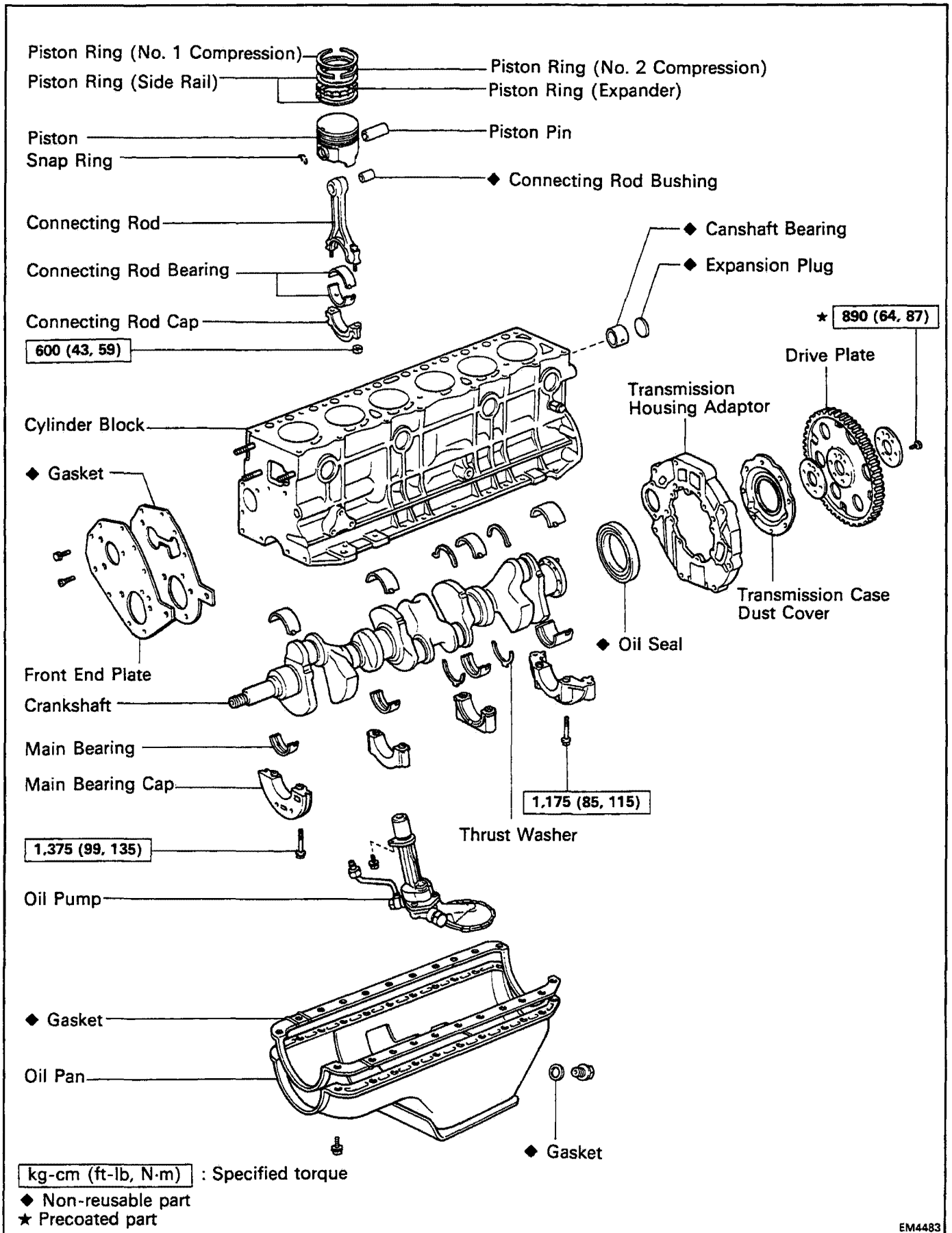

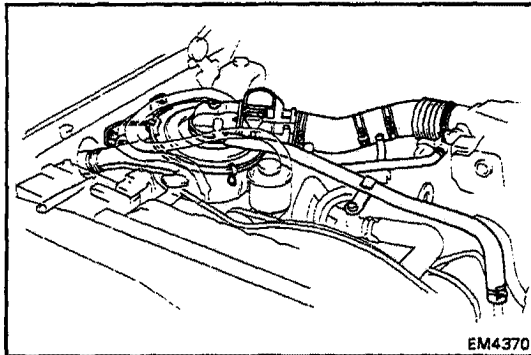
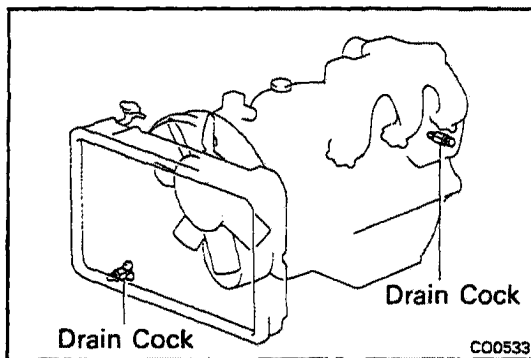

## REMOVAL OF ENGINE

1. **DRAIN ENGINE COOLANT**  
(See page CO-3)
2. **DRAIN ENGINE OIL**
3. **REMOVE HOOD**
4. **REMOVE BATTERY AND BATTERY TRAY**
5. **DISCONNECT ACCELERATOR AND THROTTLE CABLES**
6. **REMOVE AIR INTAKE HOSE, AIR FLOW METER AND AIR CLEANER ASSEMBLY**
  - (a) Disconnect the air flow meter connector and clamp.
  - (b) Disconnect following hoses:
    - ISC hose
    - Air pump hose
    - Distributor hose
    - PCV hose
    - Three hoses from the intake chamber rear side
    - Two hoses from the VCV of the charcoal canister
  - (c) Disconnect the air intake hose clamp.
  - (d) Remove the wing nut and loosen the three clips, and remove the air intake hose, air flow meter and air cleaner cap.
  - (e) Remove the air cleaner element.
  - (f) Remove the three bolts and air cleaner case.
7. **REMOVE COOLANT RESERVOIR TANK**
8. **REMOVE RADIATOR**  
(See page CO-11)
9. **DISCONNECT FOLLOWING WIRES AND CONNECTORS**
  - (a) Oil pressure connector
  - (b) High tension cord from ignition coil
  - (c) Neutral start switch and transfer connectors located near the starter
  - (d) Front differential lock connector
  - (e) Starter wire and connector
  - (f) Ground strap from starter
  - (g) Oxygen sensor connectors
  - (h) Alternator wire and connector
  - (i) Cooling fan connector
  - (j) Check connector
  - (k) Connector on RH fender apron

**10. DISCONNECT FOLLOWING HOSES:**

- (a) Heater hoses
- (b) Fuel hoses
- (c) Transfer hose
- (d) Brake booster hose
- (e) PS air control valve hose
- (f) AI hoses
- (g) Distributor hose
- (h) Emission control hoses

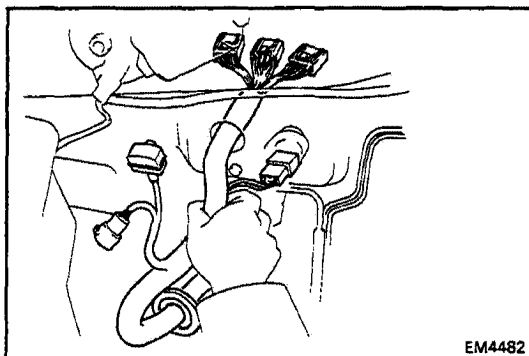
**11. DISCONNECT EFI WIRE HARNESS FROM ECU**

- (a) Remove the glove box.
- (b) Disconnect the four connectors.
- (c) Pull out the EFI wire harness from the cowl panel.

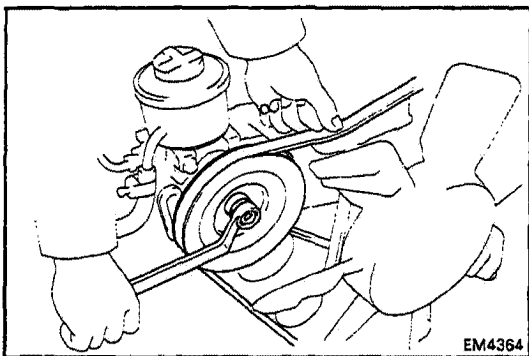
**12. REMOVE PS PUMP WITHOUT DISCONNECTING HOSES**

- (a) Push on the drive belt to hold the pulley in place and loosen the pulley nut.
- (b) Loosen the idler pulley nut and adjusting bolt, and remove the drive belt.
- (c) Remove the pulley mount nut, drive pulley and woodruff key.
- (d) Remove PS mount bolts, and remove the PS pump from the bracket.

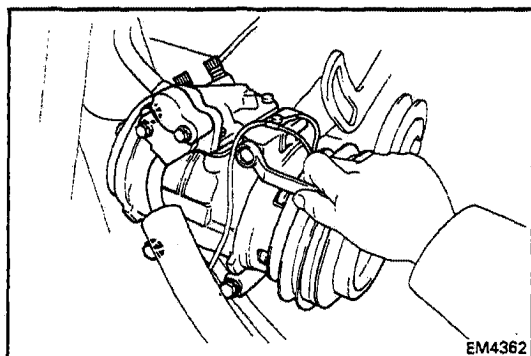
**13. REMOVE A/C COMPRESSOR WITHOUT DISCONNECTING HOSES**

- (a) Disconnect the connector.
- (b) Loosen the idler pulley nut and adjusting bolt, and remove the drive belt.
- (c) Remove the four compressor mount bolts.
- (d) Put aside the compressor, and suspend it to the fender apron with the string.

**14. RAISE VEHICLE**

**CAUTION:** Be sure the vehicle is securely supported.

**15. REMOVE TRANSFER UNDER COVER**

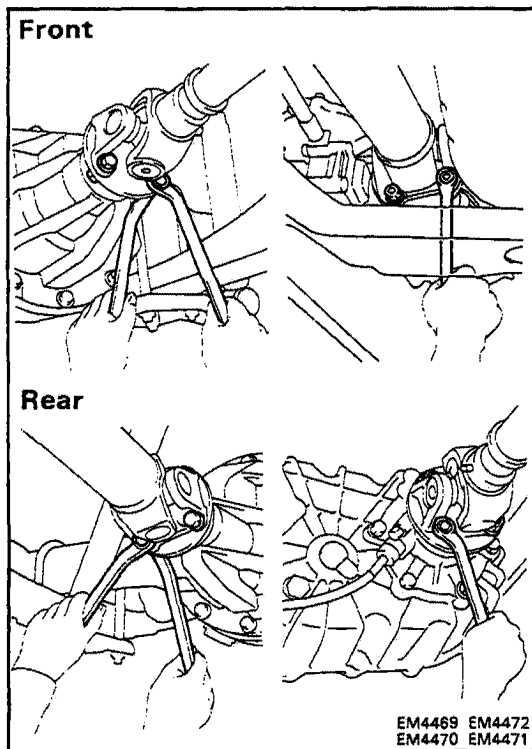

## 16. REMOVE FRONT AND REAR PROPELLER SHAFTS

- (a) Put matchmarks on the flanges.
- (b) Remove the four bolts and nuts.
- (c) Remove the four nuts.
- (d) Remove the propeller shaft.

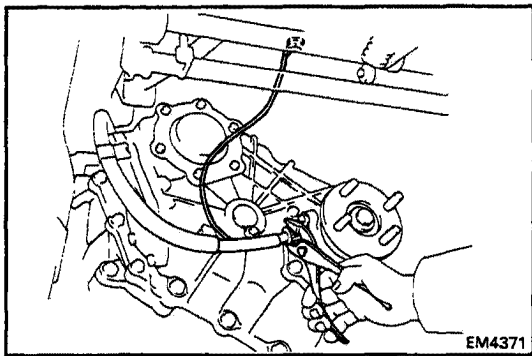

## 17. DISCONNECT SPEEDOMETER CABLE

## 18. DISCONNECT GROUND STRAP FROM BODY

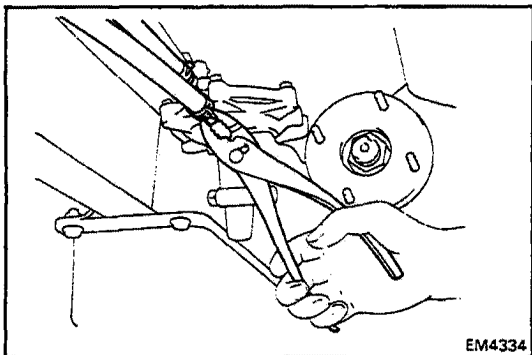

## 19. DISCONNECT TWO VACUUM HOSES FROM DIAPHRAGM CYLINDER FOR TRANSFER

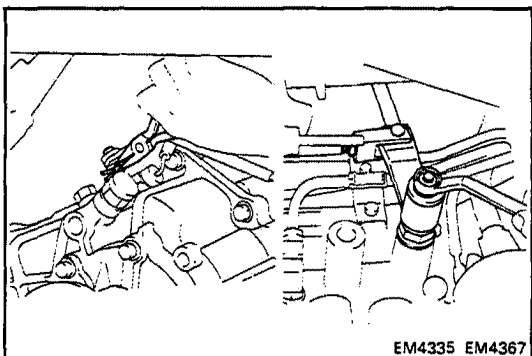

## 20. DISCONNECT TRANSFER SHIFT LEVER

- (a) Remove the clip and pin, and disconnect the shift rod from the transfer.
- (b) Remove the nut and then disconnect the washers and the transfer shift lever with shift rod.

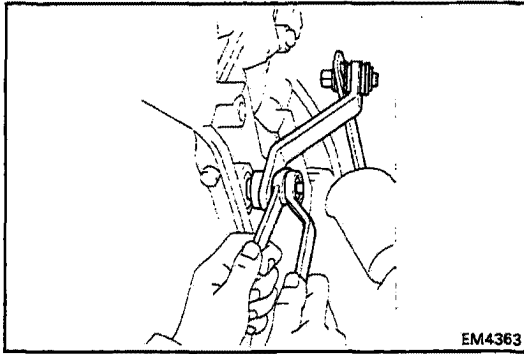
**21. DISCONNECT TRANSMISSION CONTROL ROD**

Remove the two nuts and disconnect the control rod.

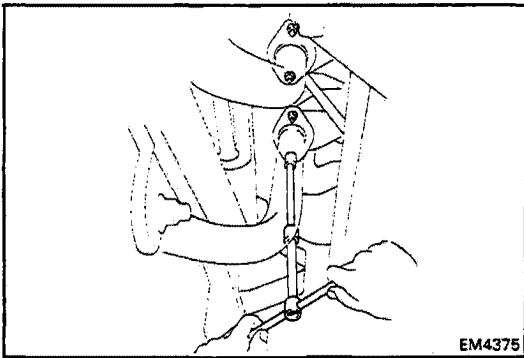
**22. DISCONNECT EXHAUST PIPE FROM EXHAUST MANIFOLD**

- (a) Remove the exhaust pipe front bracket.
- (b) Remove the four nuts, and disconnect the exhaust pipe.

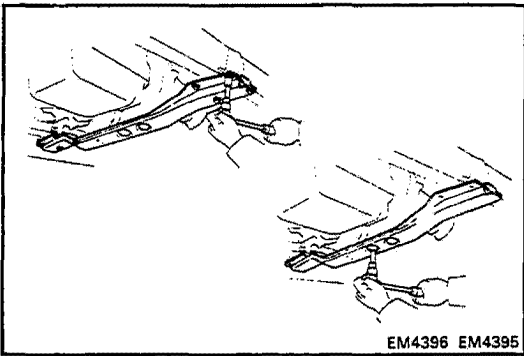
**23. PLACE JACK UNDER TRANSMISSION**

Be sure to put a wooden block between the jack and the transmission pan to prevent damage.

**24. REMOVE FRAME CROSSMEMBER**

Remove the eight bolts and two nuts, and then remove the frame crossmember.

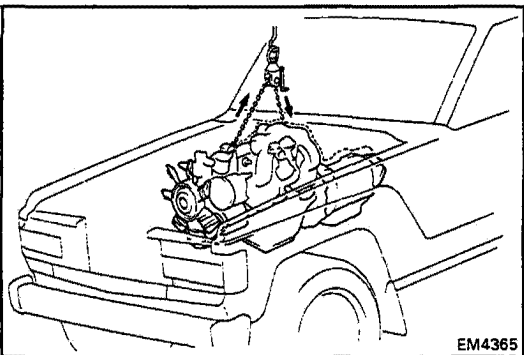
**25. REMOVE ENGINE WITH TRANSMISSION**

- (a) Attach the engine hoist chain to the two engine hangers.
- (b) Remove the mount nuts and washers.
- (c) Lift the engine with transmission out of the vehicle slowly and carefully.

NOTE: Make sure the engine is clear of all wiring and hoses.

- (d) Place the engine and transmission assembly onto the stand.

**26. REMOVE A/T OIL COOLER PIPES****27. REMOVE TRANSMISSION FROM ENGINE**

## PREPARATION FOR DISASSEMBLY

1. REMOVE DRIVE PLATE
2. REMOVE TRANSMISSION HOUSING ADAPTOR
3. INSTALL ENGINE TO ENGINE STAND FOR DISASSEMBLY
4. REMOVE CYLINDER HEAD  
(See page EM-12)
5. REMOVE ALTERNATOR
6. REMOVE WATER PUMP
7. REMOVE TIMING GEAR AND CAMSHAFT  
(See page EM-34)
8. REMOVE OIL COOLER AND OIL FILTER BRACKET  
(See page LU-12)
9. REMOVE OIL PAN AND OIL PUMP  
(See page LU-6)

## DISASSEMBLY OF CYLINDER BLOCK

(See page EM-49)

1. REMOVE FRONT END PLATE
  - (a) Using a torx socket wrench, remove the three screws.
  - (b) Remove the two bolts, front end plate and gasket.
2. CHECK CONNECTING ROD THRUST CLEARANCE
 

Using a dial indicator, measure the thrust clearance while moving the rod back and forth.

**Standard thrust clearance:** 0.160 – 0.300 mm  
(0.0063 – 0.0118 in.)

**Maximum thrust clearance:** 0.40 mm (0.0156 in.)

If clearance is greater than maximum, replace the connecting rod assembly. If necessary, replace the crankshaft.
3. REMOVE CONNECTING ROD CAPS AND CHECK OIL CLEARANCE
  - (a) Using a punch or numbering stamp, place the matchmarks on the rod and cap to ensure correct reassembly.

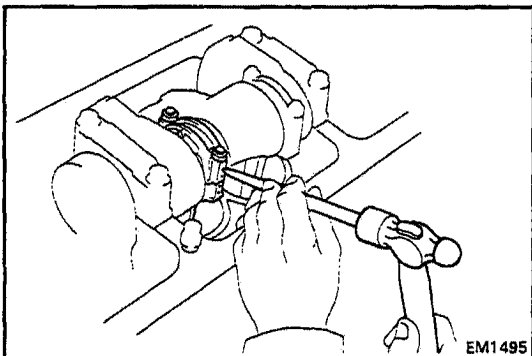
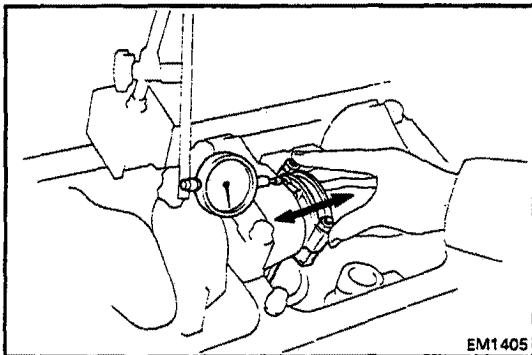
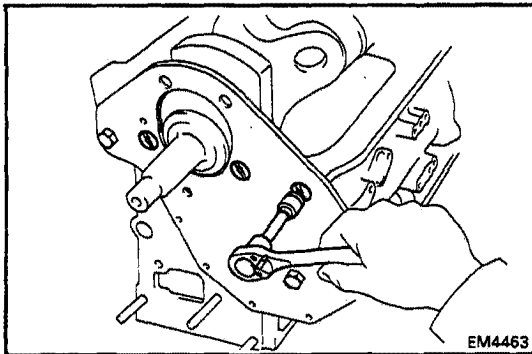

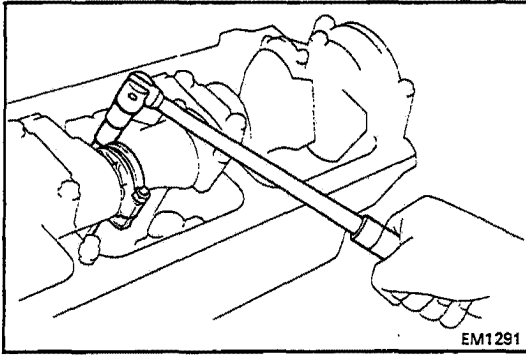

(b) Remove the connecting rod cap nuts.

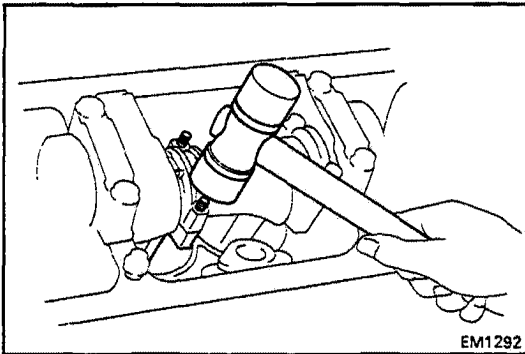

(c) Using a plastic-faced hammer, lightly tap the connecting rod bolts and lift off the connecting rod cap.

NOTE: Keep the lower bearing inserted with the connecting rod cap.

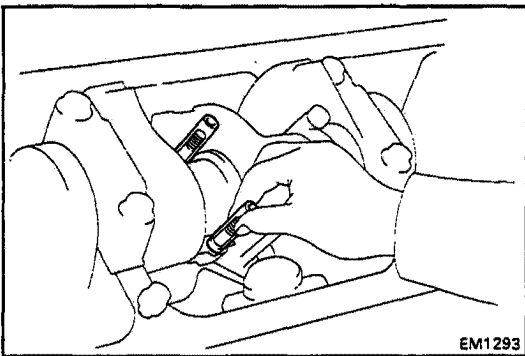

(d) Cover the connecting rod bolts with a short piece of hose to protect the crankshaft from damage.

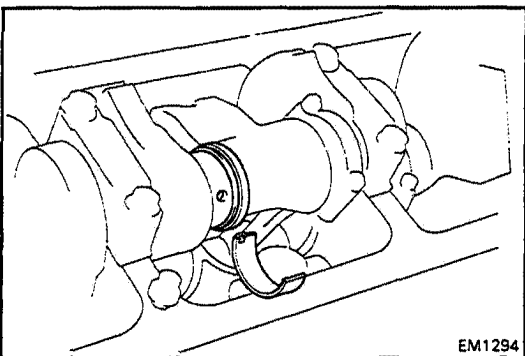

(e) Clean the crank pin and bearing.

(f) Check the crank pin and bearing for pitting and scratches.

If the crank pin or bearing are damaged, replace the bearings. If necessary, grind or replace the crankshaft.

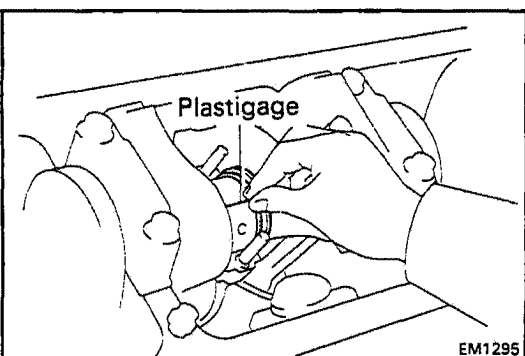

(g) Lay a strip of Plastigage across the crank pin.



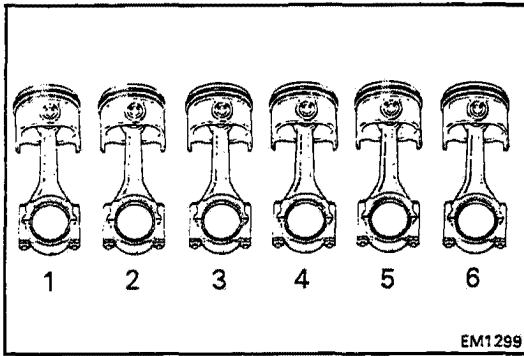

**NOTE:**

- Keep the bearings, connecting rod and cap together.
- Arrange the piston and connecting rod assemblies in correct order.

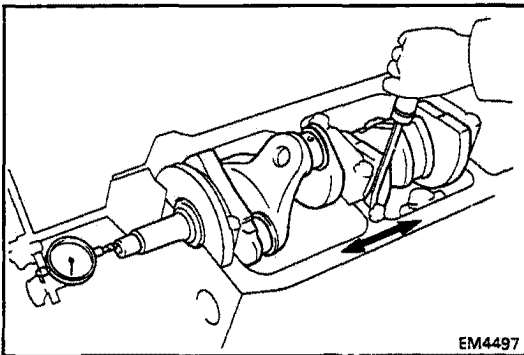

**5. CHECK CRANKSHAFT THRUST CLEARANCE**

Using a dial indicator, measure the thrust clearance while prying the crankshaft back and forth with a screwdriver.

**Standard thrust clearance:** 0.015 – 0.204 mm  
(0.0006 – 0.0080 in.)

**Maximum thrust clearance:** 0.30 mm (0.0118 in.)

If the clearance is greater than maximum, replace the thrust washers as a set.

**Thrust washer size:** STD, O/S 0.125, 0.25

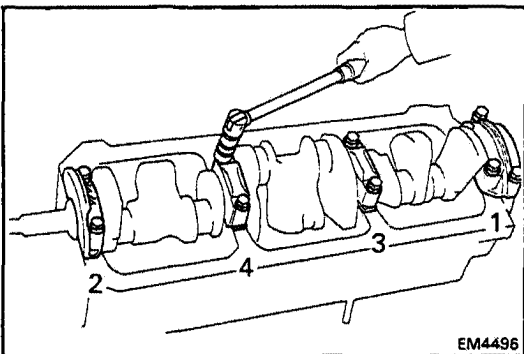

**6. REMOVE MAIN BEARING CAPS AND CHECK OIL CLEARANCE**

- (a) Uniformly loosen and remove the main bearing cap bolts in several passes, in the sequence shown.

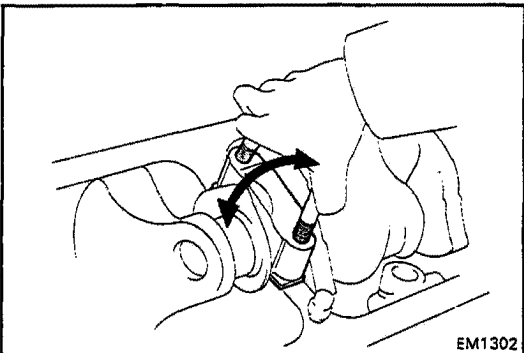

- (b) Using the removed main bearing cap bolts, wiggle the cap back and forth, and remove the caps, lower bearings and lower thrust washers (No. 3 cap only).

**NOTE:**

- Keep the lower bearing and main bearing cap together.
- Arrange the main bearing caps and lower thrust washers in correct order.

- (c) Lift out the crankshaft.

**NOTE:** Keep the upper bearings and upper thrust washers together with the cylinder block.

- (d) Clean each journal and bearing.

- (e) Check each journal and bearing for pitting and scratches.

If the journal or bearing is damaged, replace the bearings. If necessary, grind or replace the crankshaft.

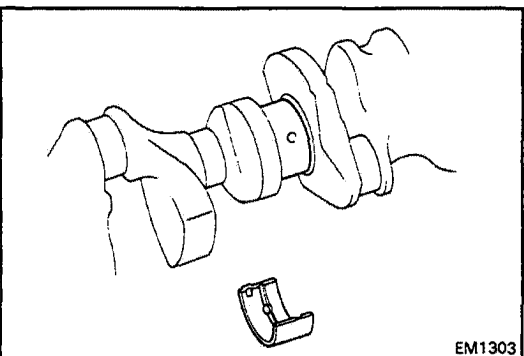

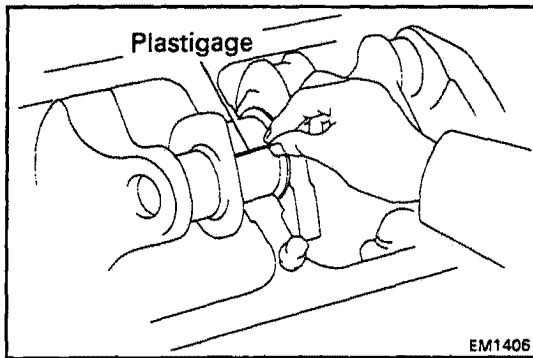

- (f) Place the crankshaft on the cylinder block.
- (g) Lay a strip of Plastigage across each journal.

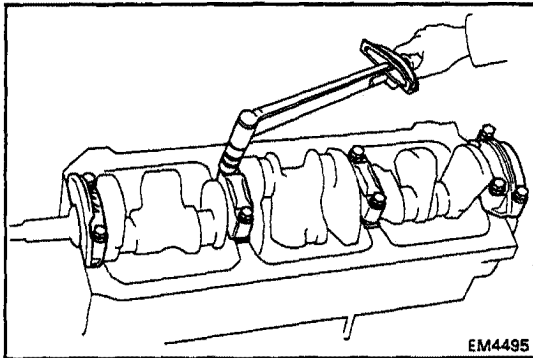

- (h) Install the main caps.  
(See step 5 on page EM-71)

**Torque:**

- 19 mm bolt head**  
1,375 kg-cm (99 ft-lb, 135 N·m)
- 17 mm bolt head**  
1,175 kg-cm (85 ft-lb, 115 N·m)

**NOTE:** Do not turn the crankshaft.

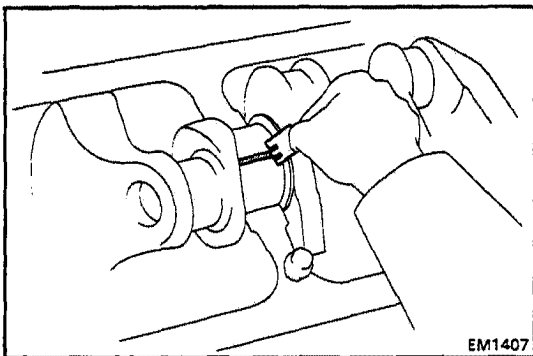

- (i) Remove the main bearing caps.
- (j) Measure the Plastigage at its widest point.

**Standard oil clearance:**

- STD size** 0.020 – 0.044 mm  
(0.0008 – 0.0017 in.)
- U/S 0.25 and 0.50** 0.021 – 0.067 mm  
(0.0008 – 0.0026 in.)

**Maximum oil clearance: 0.10 mm (0.0039 in.)**

**NOTE:** If replacing the cylinder block subassembly the bearing standard clearance will be:  
0.004 – 0.060 mm (0.002 – 0.0024 in.)

If the oil clearance is greater than maximum, replace the bearings. If necessary, grind or replace the crankshaft.

**NOTE:** If replacing a standard size bearing with a standard oil clearance, replace with one having the same number. If the number of the bearing cannot be determined, select a bearing from the table below according to the numbers imprinted on the cylinder block and crankshaft.

There are five sizes of standard bearings, marked T1, T2, T3, T4 and T5.

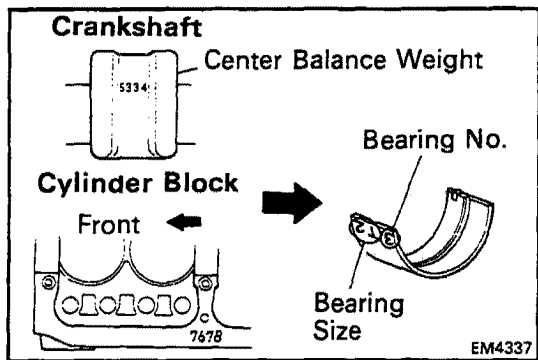

Crankshaft	Number marked								
	3			4			5		
Cylinder block	6	7	8	6	7	8	6	7	8
Bearing	T3	T4	T5	T2	T3	T4	T1	T2	T3

Example: Crankshaft "5", Cylinder Block "7"  
= Bearing "T2"

**(Reference)****Crankshaft journal diameter:**

<b>Mark "3"</b>	<b>No.1</b>	<b>66.972 – 66.980 mm</b> <b>(2.6367 – 2.6370 in.)</b>
	<b>No.2</b>	<b>68.472 – 68.480 mm</b> <b>(2.6957 – 2.6961 in.)</b>
	<b>No.3</b>	<b>69.972 – 69.980 mm</b> <b>(2.7548 – 2.7551 in.)</b>
	<b>No.4</b>	<b>71.472 – 71.480 mm</b> <b>(2.8139 – 2.8142 in.)</b>
<b>Mark "4"</b>	<b>No.1</b>	<b>66.980 – 66.988 mm</b> <b>(2.6370 – 2.6373 in.)</b>
	<b>No.2</b>	<b>68.480 – 68.488 mm</b> <b>(2.6961 – 2.6964 in.)</b>
	<b>No.3</b>	<b>69.980 – 69.988 mm</b> <b>(2.7551 – 2.7554 in.)</b>
	<b>No.4</b>	<b>71.480 – 71.488 mm</b> <b>(2.8142 – 2.8145 in.)</b>
<b>Mark "5"</b>	<b>No.1</b>	<b>66.988 – 66.996 mm</b> <b>(2.6373 – 2.6376 in.)</b>
	<b>No.2</b>	<b>68.488 – 68.496 mm</b> <b>(2.6964 – 2.6967 in.)</b>
	<b>No.3</b>	<b>69.988 – 69.996 mm</b> <b>(2.7554 – 2.7557 in.)</b>
	<b>No.4</b>	<b>71.488 – 71.496 mm</b> <b>(2.8145 – 2.8148 in.)</b>

**Cylinder block main journal bore diameter:**

<b>Mark "6"</b>	<b>No.1</b>	<b>72.010 – 72.018 mm</b> <b>(2.8350 – 2.8353 in.)</b>
	<b>No.2</b>	<b>73.510 – 73.518 mm</b> <b>(2.8941 – 2.8944 in.)</b>
	<b>No.3</b>	<b>75.010 – 75.018 mm</b> <b>(2.9531 – 2.9535 in.)</b>
	<b>No.4</b>	<b>76.510 – 76.518 mm</b> <b>(3.0122 – 3.0125 in.)</b>
<b>Mark "7"</b>	<b>No.1</b>	<b>72.018 – 72.026 mm</b> <b>(2.8353 – 2.8357 in.)</b>
	<b>No.2</b>	<b>73.518 – 73.526 mm</b> <b>(2.8944 – 2.8947 in.)</b>
	<b>No.3</b>	<b>75.018 – 75.026 mm</b> <b>(2.9535 – 2.9538 in.)</b>
	<b>No.4</b>	<b>76.518 – 76.526 mm</b> <b>(3.0125 – 3.0128 in.)</b>
<b>Mark "8"</b>	<b>No.1</b>	<b>72.026 – 72.034 mm</b> <b>(2.8357 – 2.8360 in.)</b>
	<b>No.2</b>	<b>73.526 – 73.534 mm</b> <b>(2.8947 – 2.8950 in.)</b>
	<b>No.3</b>	<b>75.026 – 75.034 mm</b> <b>(2.9538 – 2.9541 in.)</b>
	<b>No.4</b>	<b>76.526 – 76.534 mm</b> <b>(3.0128 – 3.0131 in.)</b>

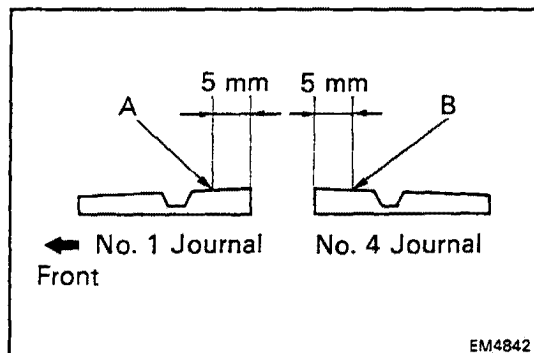
**Standard bearing thickness (at center wall):**

Mark "T1"	2.493 – 2.497 mm (0.0981 – 0.0983 in.)
Mark "T2"	2.497 – 2.501 mm (0.0983 – 0.0985 in.)
Mark "T3"	2.501 – 2.505 mm (0.0985 – 0.0986 in.)
Mark "T4"	2.505 – 2.509 mm (0.0986 – 0.0988 in.)
Mark "T5"	2.509 – 2.513 mm (0.0988 – 0.0989 in.)

NOTE: Check the bearing thickness of No. 1 and No. 4 journals in the positions A, B shown in the illustration.

(k) Completely remove the Plastigage.

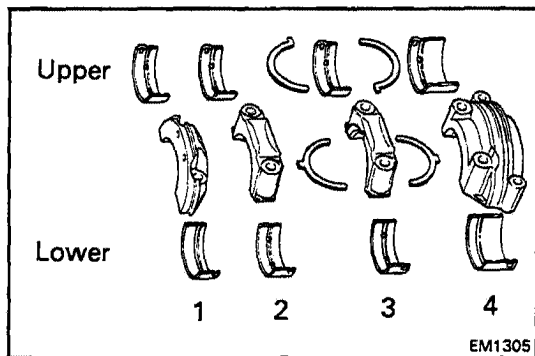
**7. REMOVE CRANKSHAFT**

- (a) Lift out the crankshaft.
- (b) Remove the upper bearings and upper thrust washers.

NOTE: Arrange the caps, bearings and thrust washers in correct order.

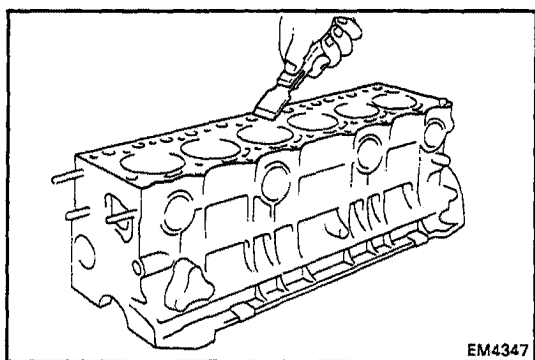
**INSPECTION OF CYLINDER BLOCK****1. REMOVE GASKET MATERIAL**

Using a gasket scraper, remove all the gasket material from the cylinder block surface.

**2. CLEAN CYLINDER BLOCK**

Using a soft brush and solvent, clean the block.

**3. INSPECT TOP OF CYLINDER BLOCK FOR FLATNESS**

Using a precision straight edge and thickness gauge, measure the surfaces contacting the cylinder head gasket for warpage.

**Maximum warpage: 0.15 mm (0.0059 in.)**

If warpage is greater than maximum, replace the cylinder block.

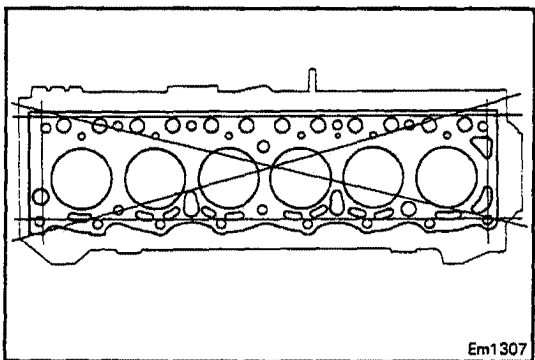

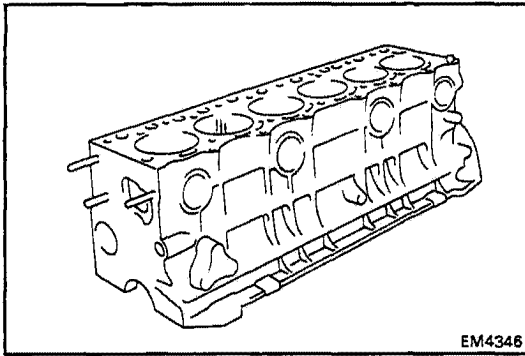

#### 4. INSPECT CYLINDERS FOR VERTICAL SCRATCHES

Visually check the cylinder for vertical scratches.

If deep scratches are present, rebore all six cylinders. If necessary, replace the cylinder block.

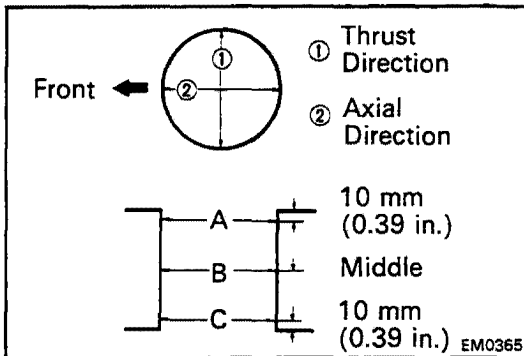

#### 5. INSPECT CYLINDER BORE DIAMETER

Using a cylinder gauge, measure the cylinder bore diameter at positions A, B and C in the thrust and axial directions.

**Standard diameter:**

STD size 94.000 – 94.030 mm  
(3.7008 – 3.7020 in.)

**Maximum diameter:**

STD size 94.23 mm (3.7098 in.)  
O/S 0.50 94.73 mm (3.7295 in.)  
O/S 1.00 95.23 mm (3.7492 in.)  
O/S 1.50 95.73 mm (3.7689 in.)

If the diameter is greater than maximum, rebore all six cylinders. If necessary, replace the cylinder block.

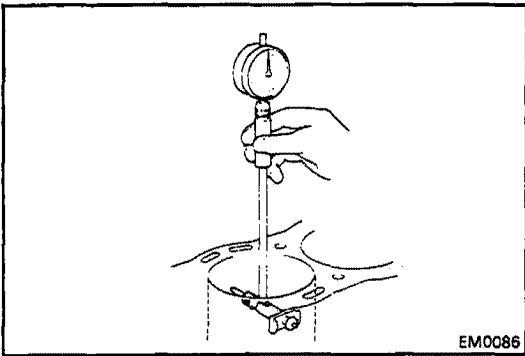

#### 6. REMOVE CYLINDER RIDGE

If the wear is less than 0.2 mm (0.008 in.), use a ridge reamer to machine the top of the cylinder.

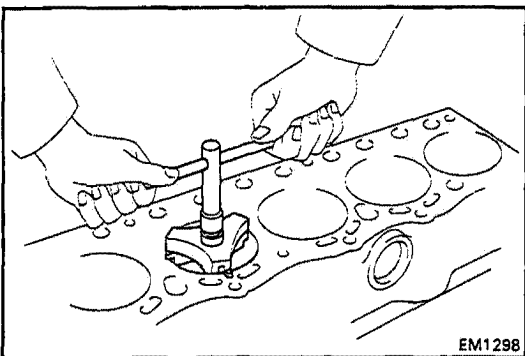

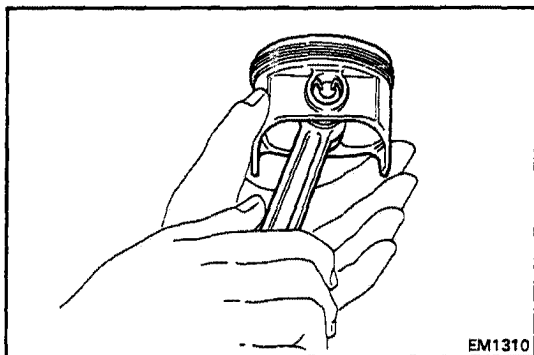

EM1310

## DISASSEMBLY OF PISTON AND CONNECTING ROD ASSEMBLIES

(See page EM-45)

### 1. CHECK FIT BETWEEN PISTON AND PIN

Try to move the piston back and forth on the piston pin. If any movement is felt, replace the piston and pin as a set.

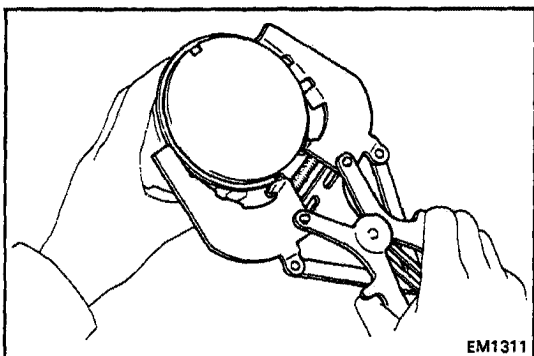

EM1311

### 2. REMOVE PISTON RINGS

(a) Using a piston ring expander, remove the compression rings.

(b) Remove the two side rails and oil ring expander by hand.

NOTE: Arrange the rings in correct order.

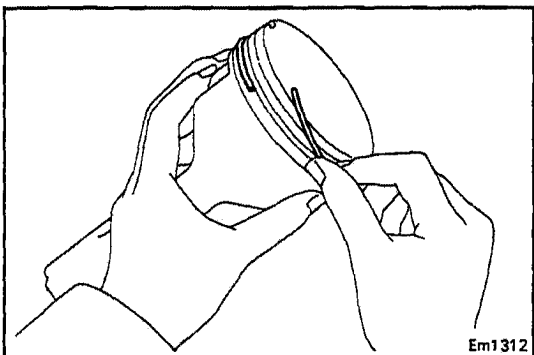

Em1312

### 3. DISCONNECT CONNECTING ROD FROM PISTON

(a) Using needle-nose pliers, remove the snap rings from the piston.

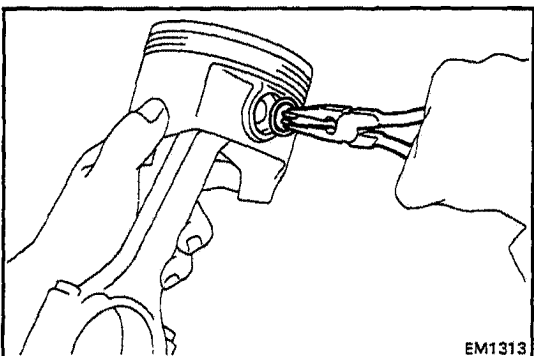

EM1313

(b) Gradually heat the piston to approx. 80°C (176°F).

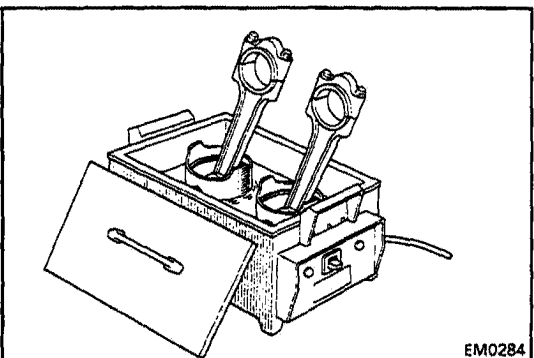

EM0284

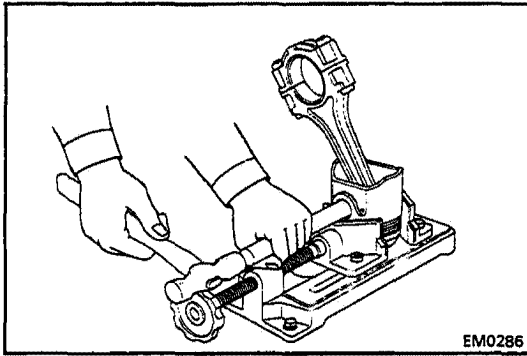

- (c) Using a plastic-faced hammer and brass bar, lightly tap out the piston pin and remove the connecting rod.

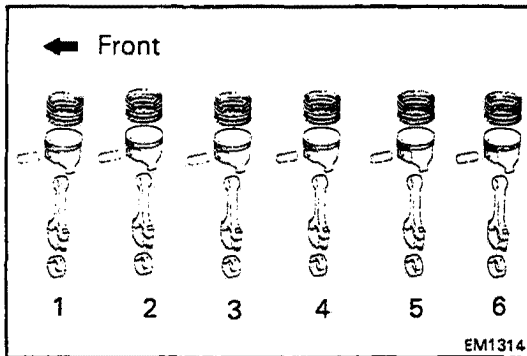

**NOTE:**

- The piston and pin are a matched set.
- Arrange the pistons, pins, rings, connecting rods and bearings in correct order.

## INSPECTION OF PISTON AND CONNECTING ROD ASSEMBLIES

### 1. CLEAN PISTONS

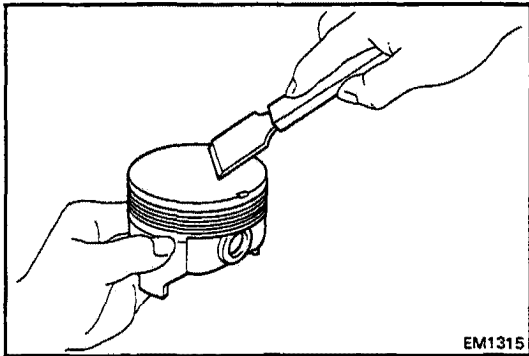

- (a) Using a gasket scraper, remove the carbon from the piston top.

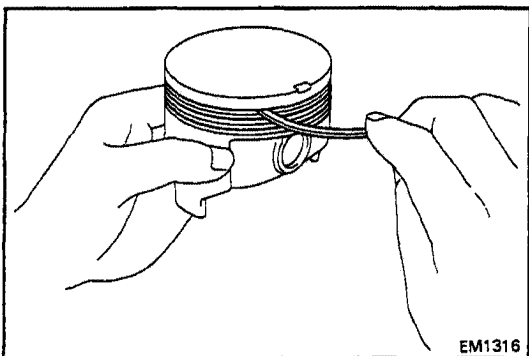

- (b) Using a groove cleaning tool or broken ring, clean the ring grooves.

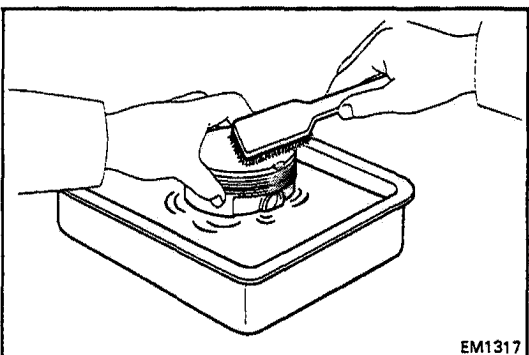

- (c) Using a soft brush and solvent, thoroughly clean the piston.

**CAUTION:** Do not damage the piston.

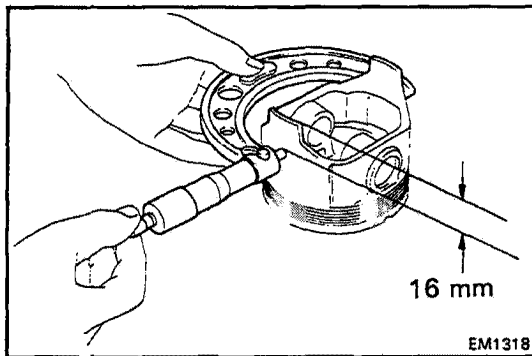

## 2. INSPECT PISTON DIAMETER AND OIL CLEARANCE

- (a) Using a micrometer, measure the piston diameter at a right angle to the piston pin hole center line, 16 mm (0.63 in.) below the skirt bottom edge.

### Standard diameter:

STD size	93.963 – 93.993 mm (3.6993 – 3.7005 in.)
O/S 0.50	94.463 – 94.493 mm (3.7190 – 3.7202 in.)
O/S 1.00	94.963 – 94.993 mm (3.7387 – 3.7399 in.)
O/S 1.50	95.463 – 95.493 mm (3.7584 – 3.7596 in.)

- (b) Measure the cylinder bore diameter in thrust directions. (See step 5 on page EM-57)
- (c) Subtract the piston diameter measurement from the cylinder bore diameter measurement.

**Oil clearance:** 0.027 – 0.047 mm  
(0.0011 – 0.0019 in.)

If the oil clearance is not within specification, replace the piston. If necessary, rebore all six cylinders and replace all six pistons. If necessary, replace the cylinder block.

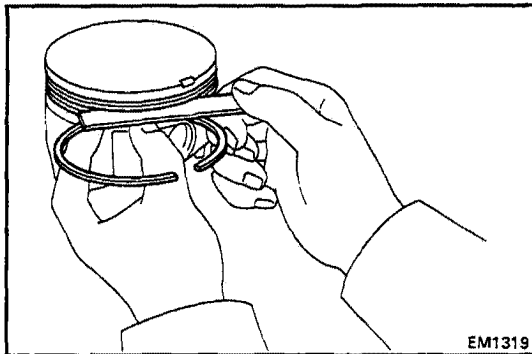

## 3. INSPECT CLEARANCE BETWEEN WALL OF PISTON RING GROOVE AND NEW PISTON RING

Using a thickness gauge, measure the clearance between new piston ring and the wall of the piston ring groove.

### Ring groove clearance:

No.1	0.030 – 0.070 mm 0012 – 0.0028 in.)
No.2	0.050 – 0.090 mm 0020 – 0.0035 in.)

If the clearance is not within specification, replace the piston.

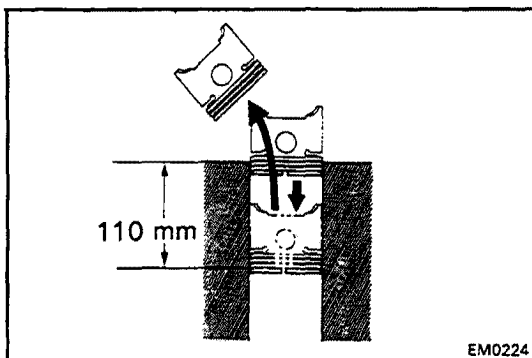

## 4. INSPECT PISTON RING END GAP

- (a) Insert the piston ring into the cylinder bore.
- (b) Using a piston, push the piston ring a little beyond the bottom of the ring travel. (110 mm or 4.33 in. from top surface of cylinder block)
- (c) Using a thickness gauge, measure the end gap.

### Standard end gap:

No. 1	0.200 – 0.420 mm (0.0079 – 0.0165 in.)
No. 2	0.500 – 0.720 mm (0.0197 – 0.0283 in.)
Oil (Side rail)	0.200 – 0.820 mm (0.0079 – 0.0323 in.)

### Maximum end gap:

No. 1	1.02 mm (0.0402 in.)
No. 2	1.32 mm (0.0520 in.)
Oil (Side rail)	1.42 mm (0.0559 in.)

If the gap is greater than maximum, replace the piston ring. If the gap is greater than maximum, even with a new piston ring, rebore the cylinder and use an O/S piston ring.

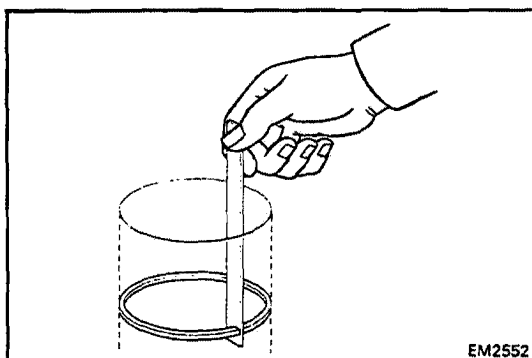

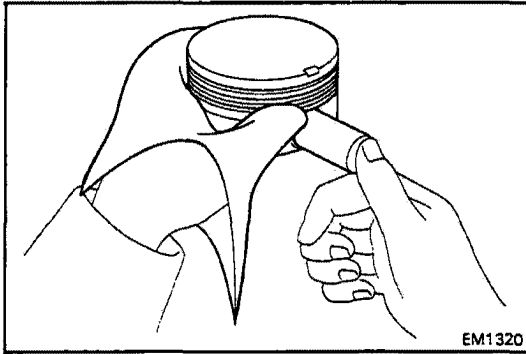

EM1320

## 5. CHECK PISTON PIN FIT

At 80°C (176°F) you should be able to push the pin into the piston with your thumb.

If the pin can be installed at a lower temperature, replace the piston and pin as a set.

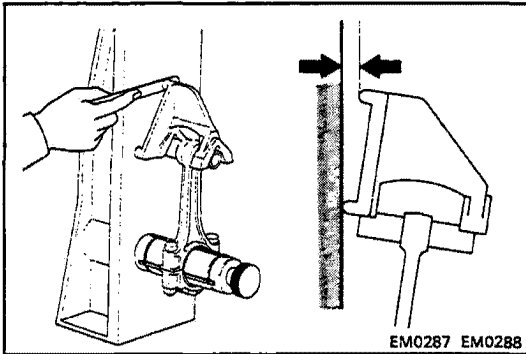

EM0287 EM0288

## 6. INSPECT CONNECTING RODS

(a) Using a rod aligner and thickness gauge, check the connecting rod alignment.

- Check for bend.

**Maximum bend:**

**0.05 mm (0.0020 in.) per 100 mm (3.94 in.)**

If bend is greater than maximum, replace the connecting rod assembly.

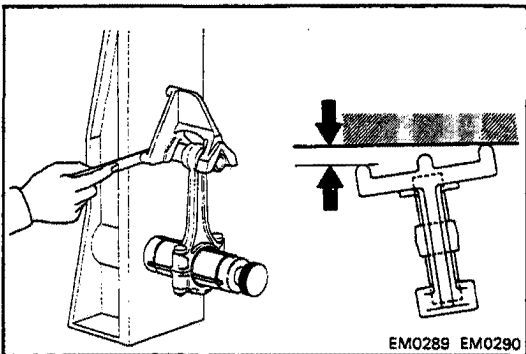

EM0289 EM0290

- Check for twist.

**Maximum twist:**

**0.15 mm (0.0059 in.) per 100 mm (3.94 in.)**

If twist is greater than maximum, replace the connecting rod assembly.

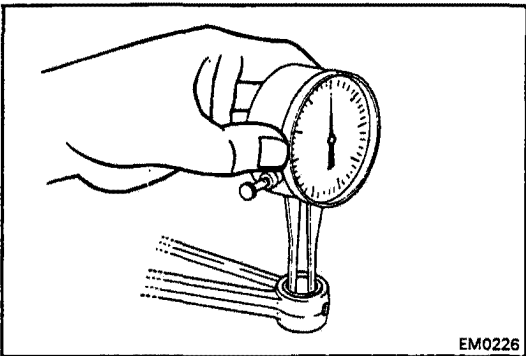

EM0226

(b) Using a caliper gauge, measure the inside diameter of the connecting rod bushing.

**Bushing inside diameter: 22.012 – 22.027 mm  
(0.8666 – 0.8672 in.)**

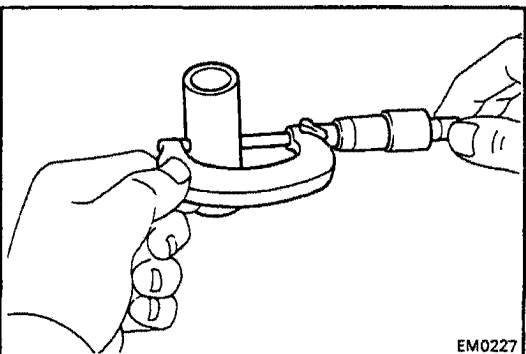

EM0227

(c) Using a micrometer, measure the piston pin diameter.

**Piston pin diameter: 22.004 – 22.019 mm  
(0.8663 – 0.8669 in.)**

(d) Subtract the piston pin diameter measurement from the bushing inside diameter measurement.

**Standard oil clearance: 0.005 – 0.011 mm  
(0.0002 – 0.0004 in.)**

**Maximum oil clearance: 0.03 mm (0.0012 in.)**

If the oil clearance is greater than maximum, replace the connecting rod bushing. If necessary, replace the piston and piston pin assembly.

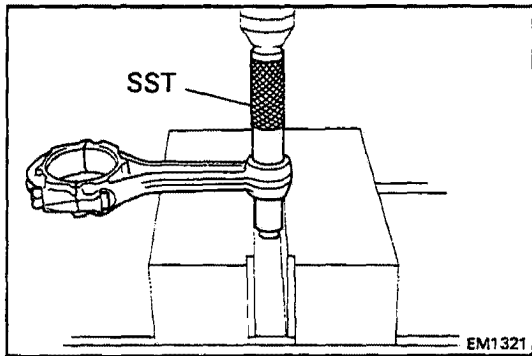

## REPLACEMENT OF CONNECTING ROD BUSHINGS

### 1. REMOVE CONNECTING ROD BUSHING

Using SST and a press, press out the bushing.

SST 09222-30010

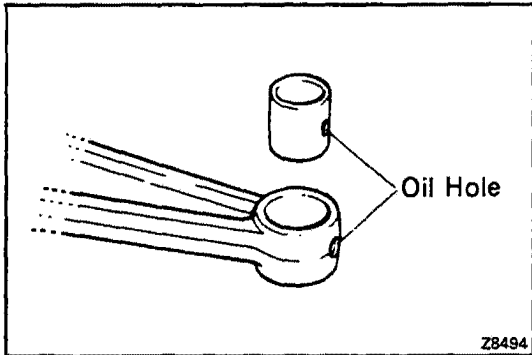

### 2. INSTALL NEW CONNECTING ROD BUSHING

(a) Align the oil holes of the bushing and connecting rod.

(b) Using SST and a press, press in the bushing.

SST 09222-30010

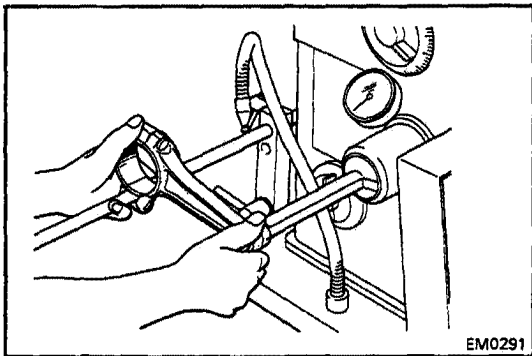

### 3. HONE ROD BUSHING AND CHECK PISTON PIN FIT IN CONNECTING ROD

(a) Using a pin hole grinder, hone the bushing to obtain the specified clearance between the bushing and piston pin.

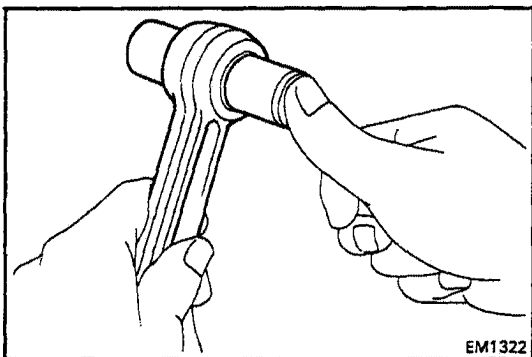

(b) Check the piston pin fit at normal room temperature. Coat the piston pin with engine oil and push it into the connecting rod with your thumb.

## BORING OF CYLINDERS

### NOTE:

- Bore all six cylinders for the oversized piston outside diameter.
- Replace the piston rings with ones to match the oversized pistons.

### 1. SELECT OVERSIZED PISTON

#### Oversized piston diameter:

O/S	0.50	94.463 – 94.493 mm (3.7190 – 3.7202 in.)
O/S	1.00	94.963 – 94.993 mm (3.7387 – 3.7399 in.)
O/S	1.50	95.463 – 95.493 mm (3.7584 – 3.7596 in.)

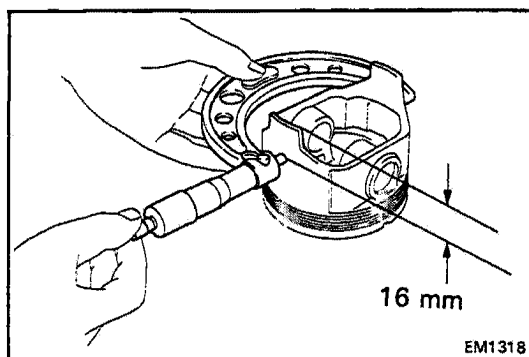

### 2. CALCULATE AMOUNT TO BORE CYLINDER

- Using a micrometer, measure the piston diameter at a right angle to the piston pin hole center line, 16 mm (0.63 in.) below the skirt bottom edge.
- Calculate the amount each cylinder is to be rebored as follows:

$$\text{Size to be rebored} = P + C - H$$

P = Piston diameter

C = Piston clearance

0.027 – 0.047 mm (0.0012 – 0.0020 in.)

H = Allowance for honing

0.02 mm (0.0008 in.) or less

### 3. BORE AND HONE CYLINDERS TO CALCULATED DIMENSIONS

Maximum honing: 0.02 mm (0.0008 in.)

**CAUTION:** Excess honing will destroy the finished roundness.

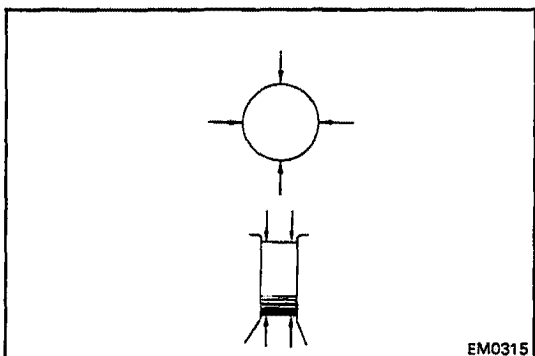
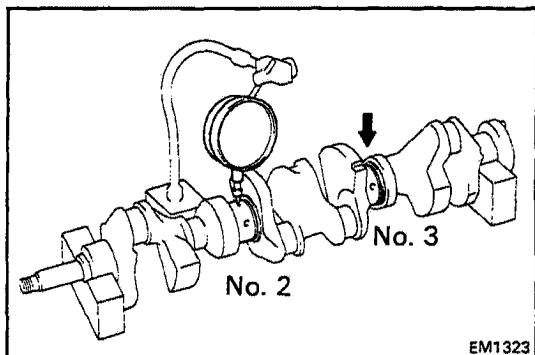

## INSPECTION AND REPAIR OF CRANKSHAFT

### 1. INSPECT CRANKSHAFT FOR RUNOUT

- (a) Place the crankshaft on V-blocks.
- (b) Using a dial indicator, measure the circle runout at the No.2 and No.3 journals.

**Maximum circle runout: 0.12 mm (0.0048 in.)**

If the circle runout is greater than maximum, replace the crankshaft.

### 2. INSPECT MAIN JOURNALS AND CRANK PINS

- (a) Using a micrometer, measure the diameter of each main journal and crank pin.

**Main journal diameter (from front side):**

<b>STD size</b>	<b>No.1</b>	<b>66.972 – 66.996 mm</b> <b>(2.6367 – 2.6376 in.)</b>
	<b>No.2</b>	<b>68.472 – 68.496 mm</b> <b>(2.6957 – 2.6967 in.)</b>
	<b>No.3</b>	<b>69.972 – 69.996 mm</b> <b>(2.7548 – 2.7557 in.)</b>
	<b>No.4</b>	<b>71.472 – 71.496 mm</b> <b>(2.8139 – 2.8148 in.)</b>
<b>U/S 0.25</b>	<b>No.1</b>	<b>66.745 – 66.755 mm</b> <b>(2.6278 – 2.6281 in.)</b>
	<b>No.2</b>	<b>68.245 – 68.255 mm</b> <b>(2.6868 – 2.6872 in.)</b>
	<b>No.3</b>	<b>69.745 – 69.755 mm</b> <b>(2.7459 – 2.7463 in.)</b>
	<b>No.4</b>	<b>71.245 – 71.255 mm</b> <b>(2.8049 – 2.8053 in.)</b>
<b>U/S 0.50</b>	<b>No.1</b>	<b>66.495 – 66.505 mm</b> <b>(2.6179 – 2.6183 in.)</b>
	<b>No.2</b>	<b>67.995 – 68.005 mm</b> <b>(2.6770 – 2.6774 in.)</b>
	<b>No.3</b>	<b>69.495 – 69.505 mm</b> <b>(2.7360 – 2.7364 in.)</b>
	<b>No.4</b>	<b>70.995 – 71.005 mm</b> <b>(2.7951 – 2.7955 in.)</b>

**Crank pin diameter:**

<b>STD size</b>	<b>52.988 – 53.000 mm</b> <b>(2.0861 – 2.0866 in.)</b>
<b>U/S 0.25</b>	<b>52.701 – 52.711 mm</b> <b>(2.0748 – 2.0752 in.)</b>
<b>U/S 0.50</b>	<b>52.451 – 52.461 mm</b> <b>(2.0650 – 2.0654 in.)</b>

If the diameter is not within specification, check the oil clearance. If necessary, grind or replace the crankshaft.

- (b) Check each main journal and crank pin for taper and out-of-round as shown.

**Maximum taper and out-of-round: 0.02 mm (0.0008 in.)**

If taper or out-of-round is greater than maximum, replace the crankshaft.

### 3. IF NECESSARY, GRIND AND HONE MAIN JOURNALS AND/OR CRANK PINS

Grind and hone the main journals and/or crank pins to the finished undersized diameter (See procedure step 2). Install new main journal and/or crank pin undersized bearings.

## INSPECTION AND REPAIR OF CAMSHAFT BEARINGS

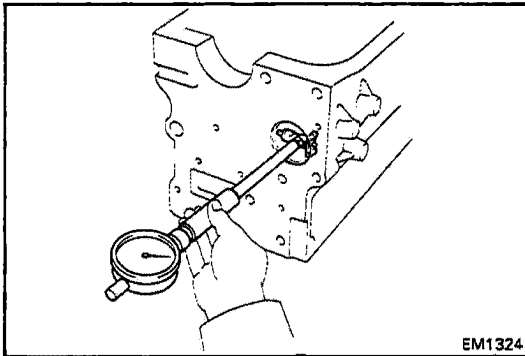

### 1. INSPECT CAMSHAFT OIL CLEARANCE

(a) Using a cylinder gauge, measure the inside diameter of the camshaft bearing.

#### Bearing inside diameter (from front side)

<b>STD size</b>	<b>No.1</b>	<b>48.000 – 48.030 mm</b> <b>(1.8898 – 1.8909 in.)</b>
	<b>No.2</b>	<b>46.500 – 46.530 mm</b> <b>(1.8307 – 1.8319 in.)</b>
	<b>No.3</b>	<b>45.000 – 45.030 mm</b> <b>(1.7717 – 1.7728 in.)</b>
	<b>No.4</b>	<b>43.500 – 43.530 mm</b> <b>(1.7126 – 1.7138 in.)</b>
<b>U/S 0.25</b>	<b>No.1</b>	<b>47.750 – 47.825 mm</b> <b>(1.8799 – 1.8829 in.)</b>
	<b>No.2</b>	<b>46.250 – 46.325 mm</b> <b>(1.8209 – 1.8238 in.)</b>
	<b>No.3</b>	<b>44.750 – 44.820 mm</b> <b>(1.7618 – 1.7646 in.)</b>
	<b>No.4</b>	<b>43.250 – 43.320 mm</b> <b>(1.7028 – 1.7055 in.)</b>
<b>U/S 0.50</b>	<b>No.1</b>	<b>47.500 – 47.575 mm</b> <b>(1.8701 – 1.8730 in.)</b>
	<b>No.2</b>	<b>46.000 – 46.075 mm</b> <b>(1.8110 – 1.8140 in.)</b>
	<b>No.3</b>	<b>44.500 – 44.570 mm</b> <b>(1.7520 – 1.7547 in.)</b>
	<b>No.4</b>	<b>43.000 – 43.070 mm</b> <b>(1.6929 – 1.6957 in.)</b>

(b) Subtract the journal diameter measurement (See page EM-38) from the bearing inside diameter measurement.

#### Standard clearance:

<b>STD size</b>	<b>0.025 – 0.075 mm</b> <b>(0.0010 – 0.0030 in.)</b>
<b>U/S 0.25 and 0.50</b>	
<b>No.1 and No.2</b>	<b>0.025 – 0.110 mm</b> <b>(0.0010 – 0.0043 in.)</b>
<b>No.3 and No.4</b>	<b>0.025 – 0.105 mm</b> <b>(0.0010 – 0.0041 in.)</b>

#### Maximum clearance:

<b>STD size</b>	<b>0.10 mm (0.0039 in.)</b>
<b>U/S 0.25 and 0.50</b>	<b>0.15 mm (0.0059 in.)</b>

If the clearance is greater than maximum, replace the camshaft bearings. If necessary, grind or replace the camshaft.

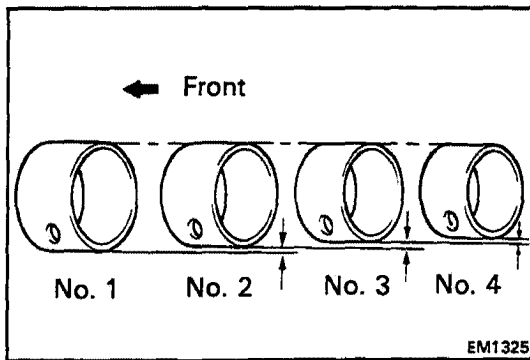

## 2. IF NECESSARY, REPLACE CAMSHAFT BEARINGS

NOTE: The outside diameter varies with each bearing.

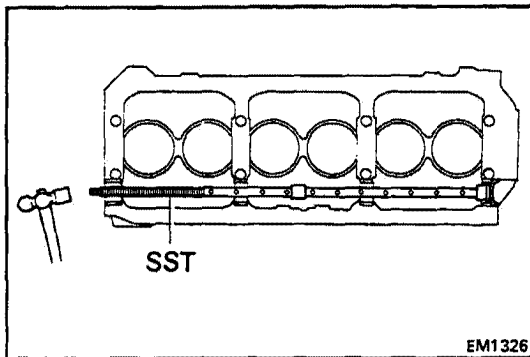

### A. Remove expansion plug

Using SST and a hammer, tap out the expansion plug.

SST 09215-00100 (09215-00130, 09215-00150, 09215-00210)

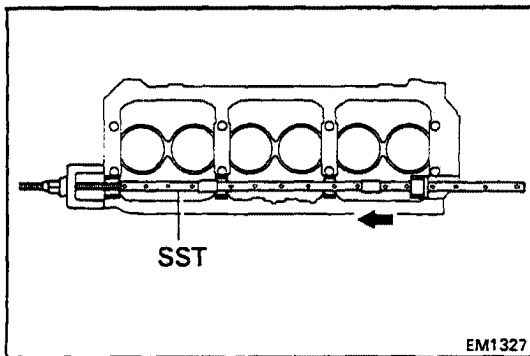

### B. Remove camshaft bearings

Using SST, remove the bearings.

SST 09215-00012 (09215-00020, 09215-00030, 09215-00410, 09215-00420) and 09215-00100 (09215-00130, 09215-00140, 09215-00150, 09215-00160, 09215-00240, 09215-00270)

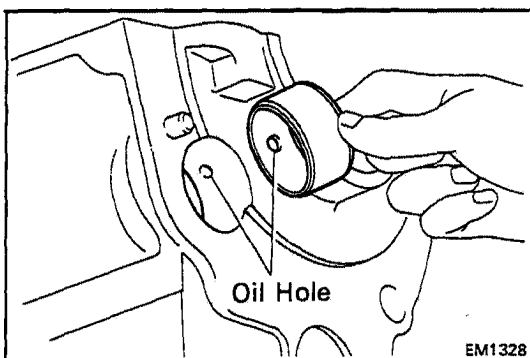

### C. Install new camshaft bearings

(a) Align the oil holes of the bearing and cylinder block.

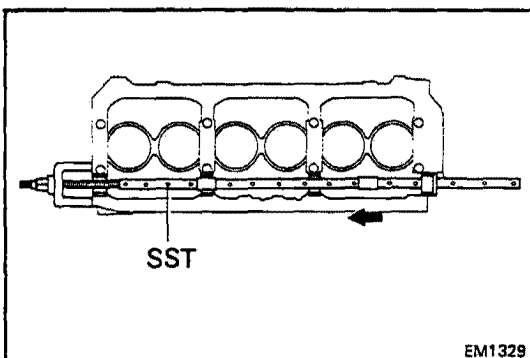

(b) Using SST install the bearings.

SST 09215-00012 (09215-00020, 09215-00030, 09215-00410, 09215-00420) and 09215-00100 (09215-00130, 09215-00140, 09215-00150, 09215-00160, 09215-00240, 09215-00270)

**D. Ream camshaft bearings**

Ream the bearings to the finished diameter.  
(See page EM-65)

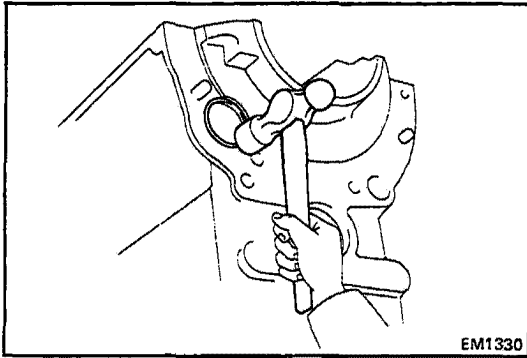
**E. Install expansion plug**

(a) Apply sealant to the expansion plug surface of the cylinder block.

**Sealant: Part No. 08833-00070, THREE BOND 1324 or equivalent.**

(b) Using a hammer, tap in a new expansion plug until its surface is flush with the cylinder block edge.

**3. IF NECESSARY, GRIND AND HONE CAMSHAFT JOURNALS**

Grind and hone the journals to the undersized finished diameter. (See page EM-38)

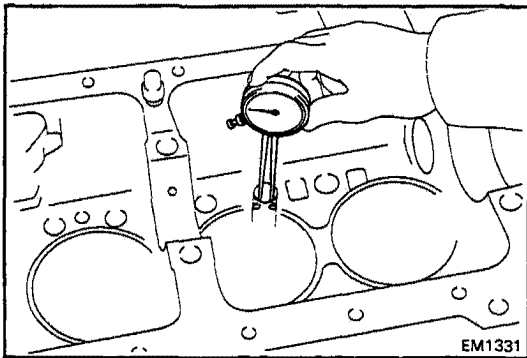
**INSPECTION OF VALVE LIFTER BORES****INSPECT VALVE LIFTER OIL CLEARANCE**

(a) Using a caliper gauge, measure the valve lifter bore diameter.

**Bore diameter: 21.417 – 21.443 mm  
(0.8432 – 0.8442 in.)**

(b) Subtract the valve lifter diameter measurement (See page EM-40) from diameter measurement.

**Standard oil clearance: 0.013 – 0.056 mm  
(0.0005 – 0.0022 in.)**

**Maximum oil clearance: 0.10 mm (0.0039 in.)**

If the clearance is greater than maximum, replace the valve lifters.

**Valve lifter size: STD, O/S 0.05**

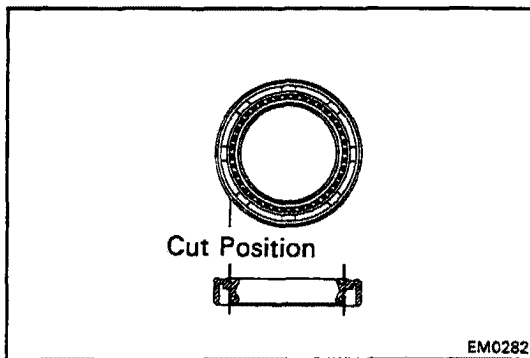

## REPLACEMENT OF CRANKSHAFT REAR OIL SEAL

### REPLACE CRANKSHAFT REAR OIL SEAL

(a) Using a knife, cut off the oil seal lip.

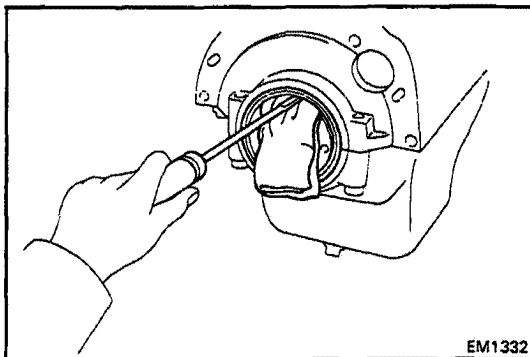

(b) Using a screwdriver, pry out the oil seal.

**CAUTION: Be careful not to damage the crankshaft. Tape the screwdriver tip.**

(c) Check the oil seal lip contact surface of the crankshaft for cracks or damage.

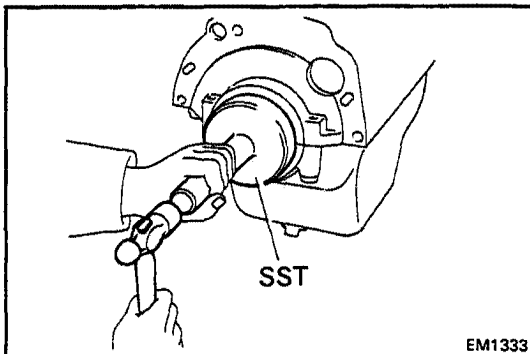

(d) Apply MP grease to a new oil seal lip.

(e) Using SST and a hammer, tap in the oil seal until its surface is flush with the cylinder block and main bearing cap edges.

SST 09223-60010

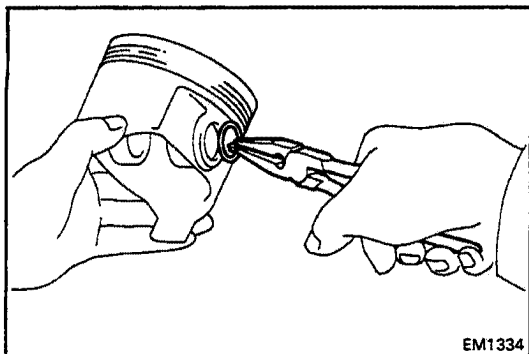

EM1334

## ASSEMBLY OF PISTON AND CONNECTING ROD

### 1. ASSEMBLE PISTON AND CONNECTING ROD

- (a) Install a new snap ring on one side of the piston pin hole.

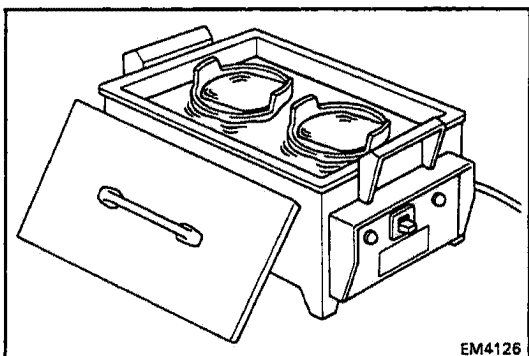

EM4126

- (b) Gradually heat the piston to approx. 80°C (176°F).

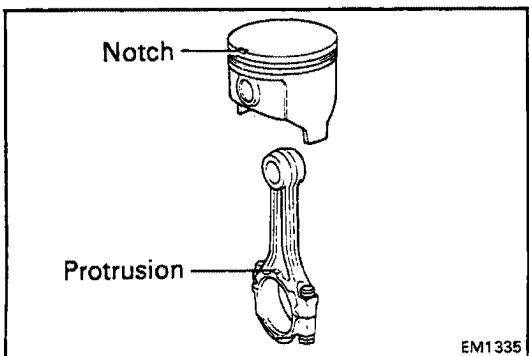

EM1335

- (c) Coat the piston pin with engine oil.

- (d) Align the notch of the piston with the protrusion of the connecting rod and push in the piston pin with your thumb.

- (e) Install a new snap ring on the other side of the pin hole.

### 2. INSTALL PISTON RINGS

- (a) Install the oil ring expander and two side rails by hand.

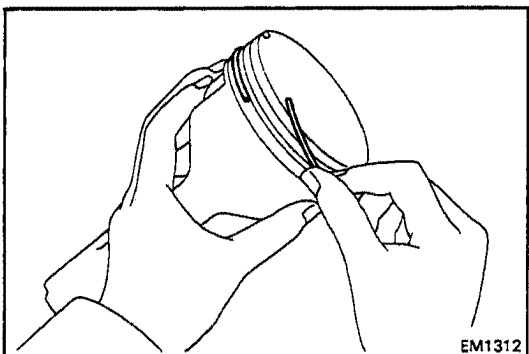

EM1312

- (b) Using a piston ring expander, install the two compression rings with the code mark facing upward.

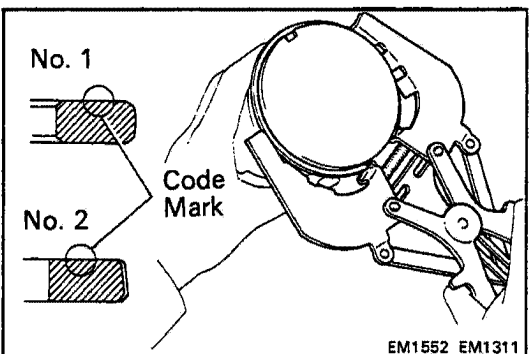

EM1552 EM1311

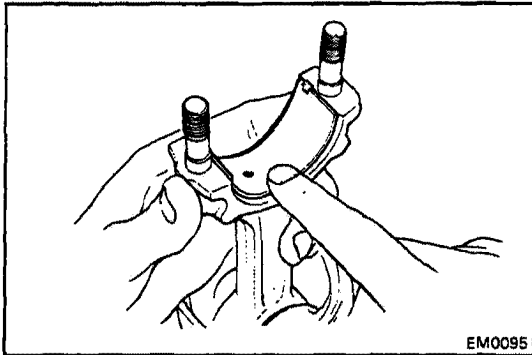
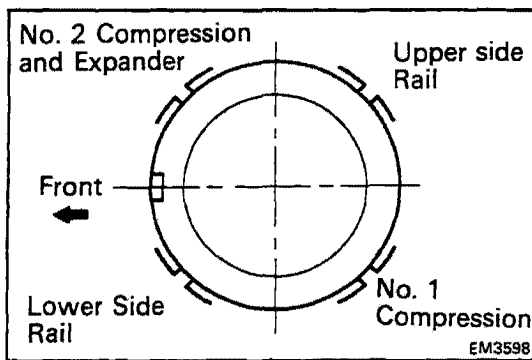

- (c) Position the piston rings so that the ring ends are as shown.

**CAUTION:** Do not align the end gaps.

### 3. INSTALL CONNECTING ROD BEARINGS

- Align the bearing claw with the claw groove of the connecting rod or connecting rod cap.
- Install the bearing in the connecting rod and rod cap.

**CAUTION:** Install the bearings with the oil hole in the connecting rod.

## ASSEMBLY OF CYLINDER BLOCK

(See page EM-45)

### NOTE:

- Thoroughly clean all parts to be assembled.
- Before installing the parts, apply new engine oil to all sliding and rotating surfaces.
- Replace all gaskets, O-rings and oil seals with new parts.

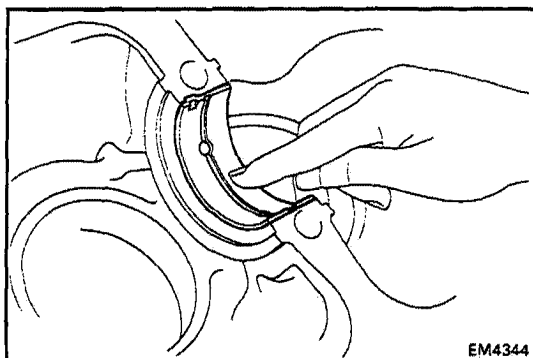
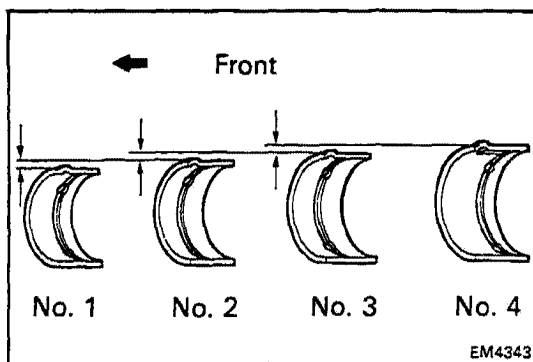

### 1. INSTALL MAIN BEARINGS

#### NOTE:

- The outside diameter varies with each bearing.
- All main bearing have oil holes except No. 1 and No. 4 bearings on the lower side.

- Align the bearing claw with the the claw groove of the main bearing cap or cylinder block.
- Install the bearing in the cylinder block and bearing caps.

**CAUTION:** Install the bearing with the oil hole in the block.

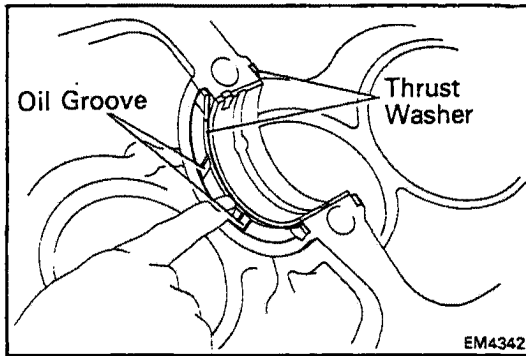

## 2. INSTALL UPPER THRUST WASHERS

Install the thrust washers under the No. 3 main bearing cap position of the block with the oil grooves facing outward.

## 3. PLACE CRANKSHAFT ON CYLINDER BLOCK

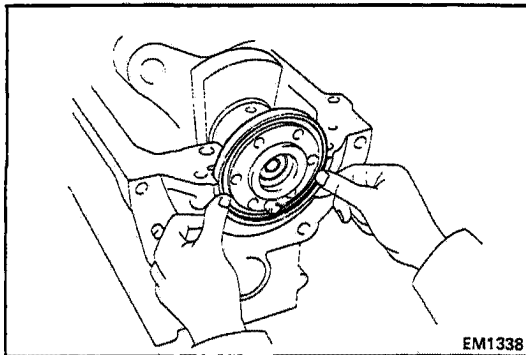

## 4. INSTALL NEW CRANKSHAFT REAR OIL SEAL

- Apply MP grease to the oil seal lip.
- Push in the oil seal until its surface is flush with the cylinder block edge.

**CAUTION:** Be careful not to install the oil seal slantwise.

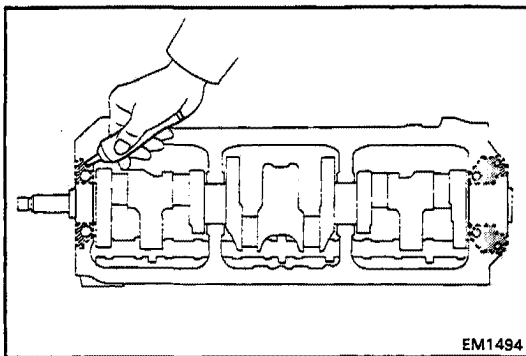

## 5. INSTALL MAIN BEARING CAPS AND LOWER THRUST WASHERS

- Apply seal packing to the main bearing installation surface of the cylinder block.

**Seal packing:** Part No. 08820-00080 or equivalent

**CAUTION:** Be careful not to apply seal packing to the main bearing.

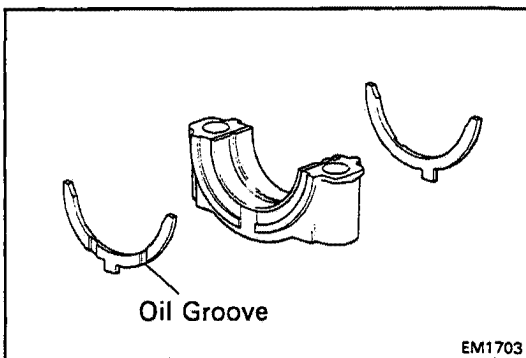

- Install the lower thrust washers on the No. 3 main bearing cap with the grooves facing outward.

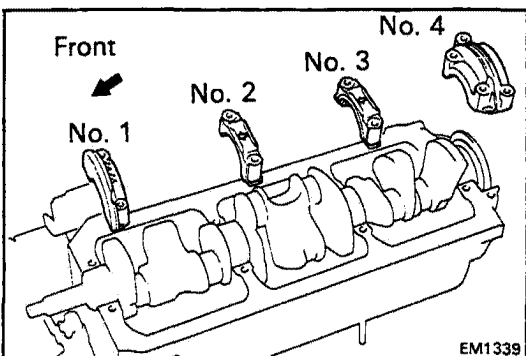

- Install the main bearing caps in their proper location.

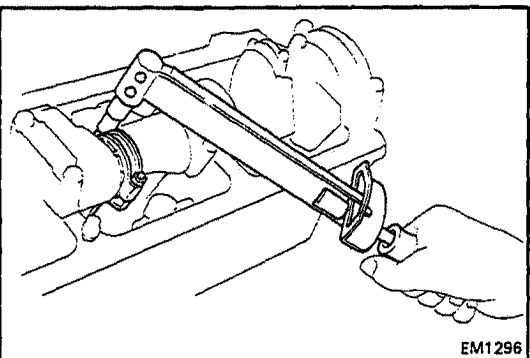
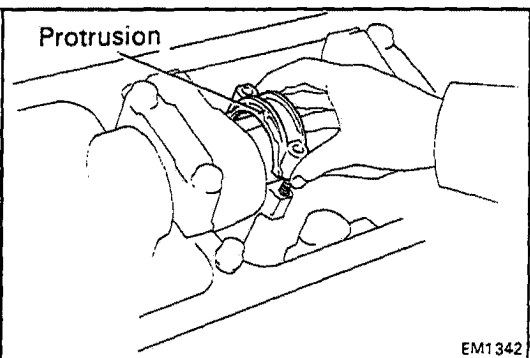
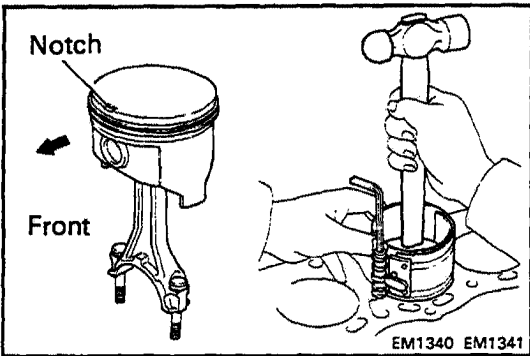
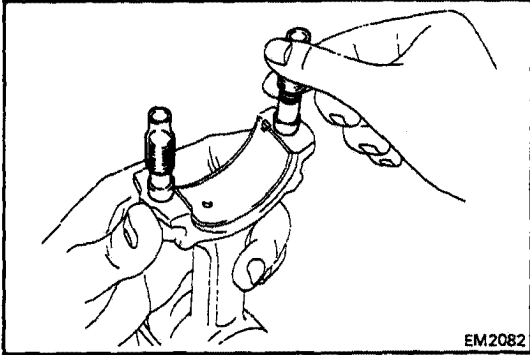
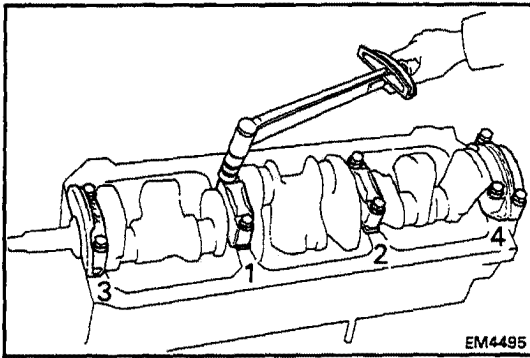

- (d) Apply a light coat of engine oil to the threads and the bolt heads of the main bearing caps.
- (e) Install and uniformly tighten the ten bolts of the main bearing caps in several passes, in the sequence shown.

**Torque:****19 mm bolt head****1,375 kg-cm (99 ft-lb, 135 N·m)****17 mm bolt head****1,175 kg-cm (85 ft-lb, 115 N·m)**

- (f) Check that the crankshaft turns smoothly.
- (g) Check the crankshaft thrust clearance.  
(See step 5 on page EM-53)

**6. INSTALL PISTON AND CONNECTING ROD ASSEMBLIES**

- (a) Cover the connecting rod bolts with a short piece of hose to protect the crankshaft from damage.
- (b) Using a piston ring compressor, push the correctly numbered piston and connecting rod assemblies into the cylinder with the notch of the piston facing forward.

**7. INSTALL CONNECTING ROD CAPS**

- (a) Match the numbered cap with the numbered connecting rod.
- (b) Install the connecting rod cap with the protrusion facing forward.

- (c) Apply a light coat of engine oil to the threads and under the nuts of the connecting rod cap.
- (d) Install and alternately tighten the connecting rod cap nuts in several passes.

**Torque: 600 kg-cm (43 ft-lb, 59 N·m)**

- (e) Check that the crankshaft turns smoothly.
- (f) Check the connecting rod thrust clearance.  
(See step 2 on page EM-50)

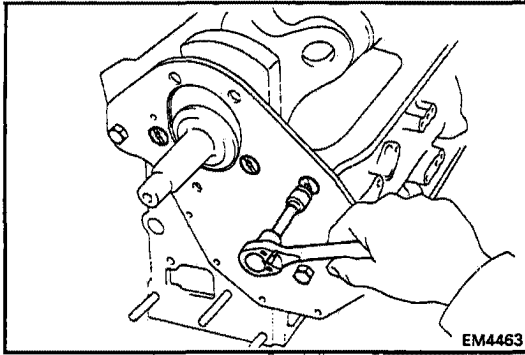

## 8. INSTALL FRONT END PLATE

- (a) Install the end plate with the two bolts.
- (b) Using a torx socket wrench, torque the screws.

**Torque: 250 kg-cm (18 ft-lb, 25 N·m)**

- (c) Torque the bolts.

**Torque: 310 kg-cm (22 ft-lb, 30 N·m)**

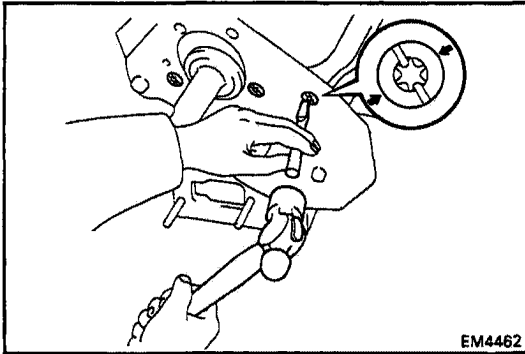

- (d) Using a chisel and hammer, stake the screws.

## POST ASSEMBLY

1. **INSTALL OIL PUMP AND OIL PAN**  
(See page LU-10)
2. **INSTALL OIL COOLER AND OIL FILTER BRACKET**  
(See page LU-14)
3. **INSTALL TIMING GEARS AND CAMSHAFT**  
(See page EM-41)
4. **INSTALL WATER PUMP**
5. **INSTALL CYLINDER HEAD**  
(See page EM-28)
6. **REMOVE ENGINE STAND**
7. **INSTALL TRANSMISSION HOUSING ADAPTOR**

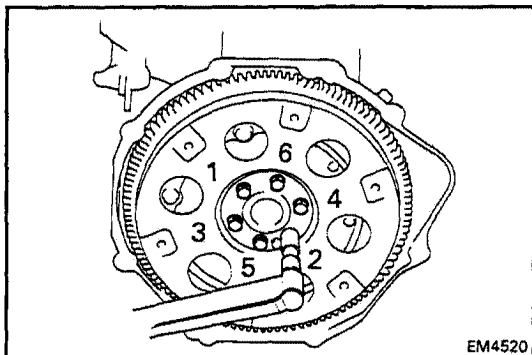
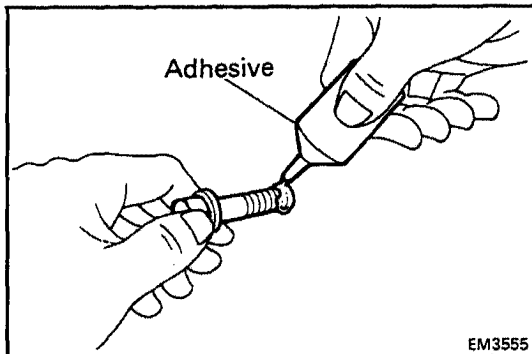

### 8. **INSTALL DRIVE PLATE**

- (a) Clean the mount bolt threads and crankshaft bolt holes of any residual sealer, oil foreign particles. Remove any oil with kerosene or gasoline.
- (b) Apply adhesive to two or three threads of the mount bolt end.

**Adhesive: Part No. 08833-00070, THREE BOND 1324 or equivalent**

#### NOTE:

- This sealant will not harden while exposed to air.
  - It will act as a sealer or binding agent only when applied to threads, etc. and the air is cut off.
- (c) Install the drive plate on the crankshaft.
  - (d) Install and uniformly tighten the bolts in several passes, in the sequence shown.

**Torque: 890 kg-cm (64 ft-lb, 87 N·m)**

## INSTALLATION OF ENGINE

1. INSTALL TRANSMISSION TO ENGINE
2. INSTALL A/T OIL COOLER PIPES

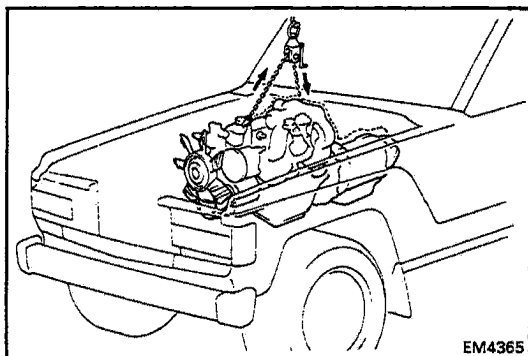

3. INSTALL ENGINE WITH TRANSMISSION IN VEHICLE

- (a) Attach the engine hoist chain to the engine hangers.
- (b) Lower the engine into the engine compartment.
- (c) Align the engine with the transmission and engine mounting supports.
- (d) Install the washers and mount nuts.
- (e) Remove the hoist chain.

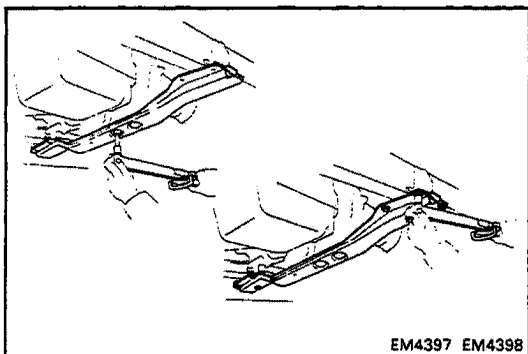

4. RAISE VEHICLE

**CAUTION:** Be sure the vehicle is securely supported.

5. INSTALL FRAME CROSSMEMBER

Install the frame crossmember with the eight bolts and two nuts.

**Torque:** Bolt 400 kg-cm (29 ft-lb, 39 N·m)  
Nut 600 kg-cm (43 ft-lb, 59 N·m)

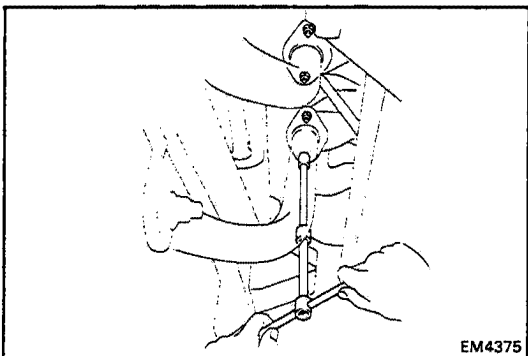

6. CONNECT EXHAUST PIPE TO EXHAUST MANIFOLD

- (a) Place two new gaskets on the exhaust pipe.
- (b) Connect the exhaust pipe with four new nuts.

**Torque:** 630 kg-cm (46 ft-lb, 62 N·m)

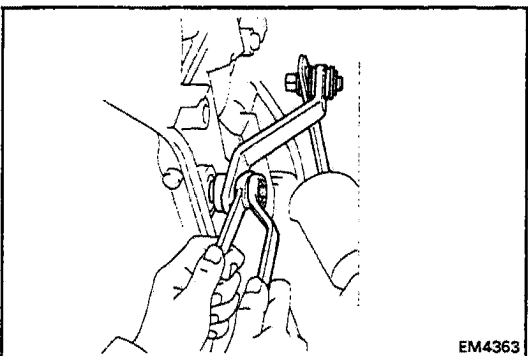

7. CONNECT TRANSMISSION CONTROL ROD

Connect the control rod with the two nuts.

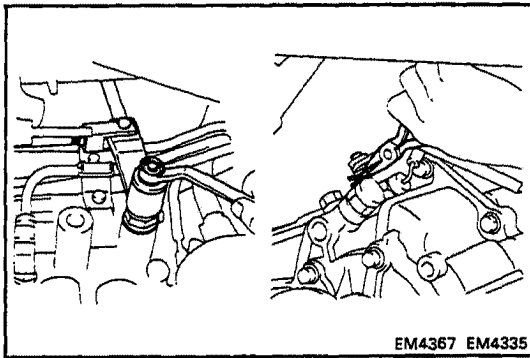
**8. CONNECT TRANSFER SHIFT LEVER**

- (a) Connect the transfer shift lever with shift rod assembly with the nut and washers.
- (b) Connect the shift rod to the transfer with the pin and clip.

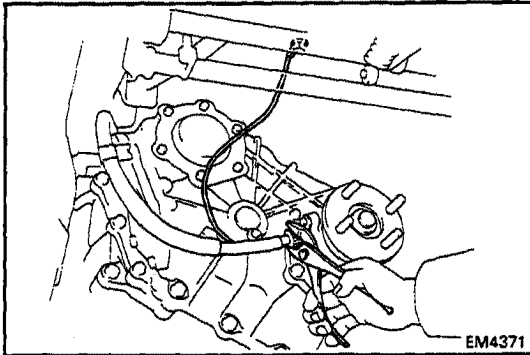
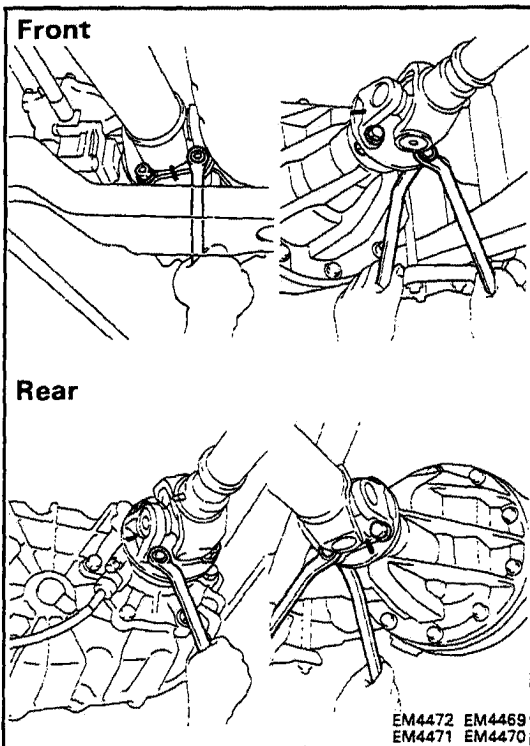
**9. CONNECT GROUND STRAP TO BODY****10. CONNECT SPEEDOMETER CABLE****11. INSTALL FRONT AND REAR PROPELLER SHAFTS**

- (a) Align the matchmarks on the flanges and connect the flanges with the four nuts.
- (b) Torque the nuts.

**Torque: 900 kg-cm (65 ft-lb, 88 N·m)**

- (a) Align the matchmarks on the flanges and connect the flanges with the four bolts and nuts.
- (b) Torque the bolts and nuts.

**Torque: 900 kg-cm (65 ft-lb, 88 N·m)**

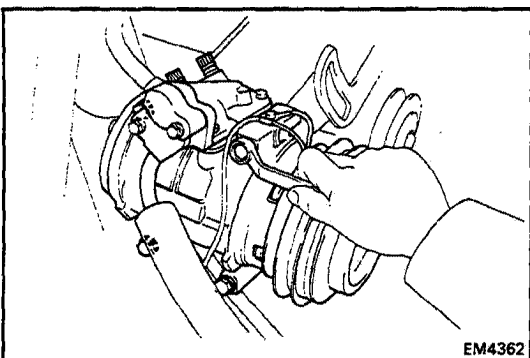
**12. INSTALL TRANSFER UNDER COVER****13. INSTALL A/C COMPRESSOR**

- (a) Install the A/C compressor with the four bolts.
- (b) Install and adjust the drive belt.  
(See page MA-4)

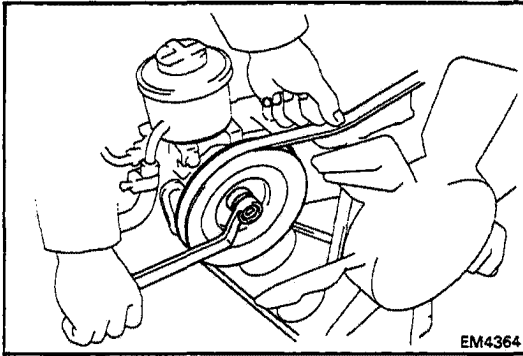
**14. INSTALL PS PUMP**

- (a) Install the PS pump with the two bolts. Do not tighten the bolts.
- (b) Install the woodruff key, drive pulley with the plate washer spring washer and mount nut.
- (c) Install and adjust drive belt (See page MA-4)
- (d) Push on the drive belt to hold the pulley in place and torque the pulley nut.

**Torque: 480 kg-cm (35 ft-lb, 47 N·m)**

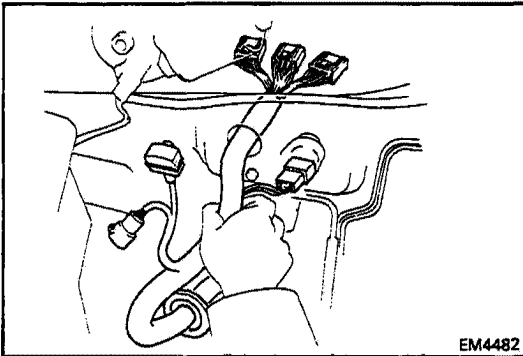
**15. CONNECT EFI WIRE HARNESS TO ECU**

- (a) Push in the EFI wire harness through the cowl panel.
- (b) Connect the four connectors.
- (c) Install the glove box.

**16. CONNECT FOLLOWING HOSES:**

- (a) Heater hoses
- (b) Fuel hoses
- (c) Transfer hose
- (d) Brake booster hose
- (e) PS air control valve hose
- (f) AI hoses
- (g) Distributor hose
- (h) Emission control hoses

**17. CONNECT FOLLOWING WIRES AND CONNECTORS**

- (a) Oil pressure connector
- (b) High tension cord from ignition coil
- (c) Neutral start switch and transfer connectors located near the starter
- (d) Front differential lock connector
- (e) Starter wire and connector
- (f) Ground strap from starter
- (g) Oxygen sensor connectors
- (h) Alternator wire and connector
- (i) Cooling fan connector
- (j) Check connector
- (k) Connector on RH fender apron

**18. INSTALL RADIATOR**  
(See page CO-11)**19. INSTALL COOLANT RESERVOIR TANK**

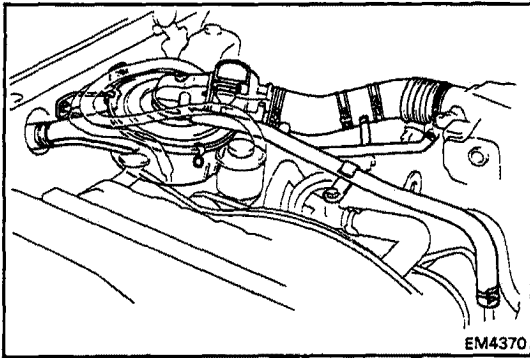

- 20. INSTALL AIR INTAKE HOSE, AIR FLOW METER AND AIR CLEANER ASSEMBLY**
- Install the air cleaner case with the three bolt.
  - Install the air cleaner element.
  - Install the air intake hose, air flow meter and air cleaner cap with the wing nut and three clips.
  - Connect following hoses:
    - ISC hose
    - Air pump hose
    - Distributor hose
    - PCV hose
    - Three hoses from the intake chamber rear side
    - Two hoses from the VCV of the charcoal canister
- 21. CONNECT ACCELERATOR AND THROTTLE CABLES, AND ADJUST THEM**
- 22. FILL WITH ENGINE COOLANT (See page CO-3)**
- Capacity
- w/ Front heater  
17.5 liters (18.5 US qts, 15.4 Imp. qts)
  - w/ Front and rear heaters  
19.5 liters (20.6 US qts, 17.2 Imp. qts)
- 23. FILL WITH ENGINE OIL (See page LU-4)**
- Capacity:
- Drain and refill
  - w/o Oil filter change  
7.0 liters (7.4 US qts, 6.2 Imp. qts)
  - w/ Oil filter change  
7.8 liters (8.2 US qts, 6.9 Imp. qts)
  - Dry full 8.0 liters (8.5 US qts, 7.0 Imp. qts)
- 24. INSTALL BATTERY TRAY AND BATTERY**
- 25. START ENGINE AND CHECK FOR LEAKS**
- 26. PERFORM ENGINE ADJUSTMENT**
- Adjust the ignition timing.  
(See steps 10 to 14 on page IG-11)
- Ignition timing: 7° BTDC @ idle  
(w/ Terminals TE1 and E1 short-circuited)
- Adjust the valve clearance. (See page EM-7)
- Valve clearance (Hot):
- Intake 0.20 mm (0.008 in.)
  - Exhaust 0.35 mm (0.014 in.)
- 27. INSTALL HOOD**
- 28. PERFORM ROAD TEST**
- Check for abnormal noise, shock, slippage and smooth operation.
- 29. RECHECK ENGINE COOLANT LEVEL AND OIL LEVEL**

# EMISSION CONTROL SYSTEMS

	Page
SYSTEM PURPOSE .....	EC-2
COMPONENT LAYOUT AND SCHEMATIC DRAWING .....	EC-3
POSITIVE CRANKCASE VENTILATION (PCV) SYSTEM .....	EC-4
FUEL EVAPORATIVE EMISSION CONTROL (EVAP) SYSTEM .....	EC-6
DASH POT (DP) SYSTEM .....	EC-9
EXHAUST GAS RECIRCULATION (EGR) SYSTEM .....	EC-11
AIR INJECTION (AI) SYSTEM .....	EC-16
THREE-WAY CATALYST (TWC) SYSTEM ....	EC-21

**NOTE: TROUBLESHOOTING**  
(See page EM-2)

**EC**

## SYSTEM PURPOSE

System	Abbreviation	Purpose
Positive crankcase ventilation	PCV	Reduced blow-by gas (HC)
Fuel evaporative emission control	EVAP	Reduced evaporative HC
Dash pot	DP	Reduces HC and CO
Exhaust gas recirculation	EGR	Reduces NOx
Air injection	AI	Reduces HC and CO
Three-way catalyst	TWC	Reduces HC, CO and NOx
Electronic fuel injection*	EFI	Regulates all engine conditions for reduction of exhaust emissions.

\* For inspection and repair of the EFI system, refer to the EFI section of this manual.

# COMPONENT LAYOUT AND SCHEMATIC DRAWING

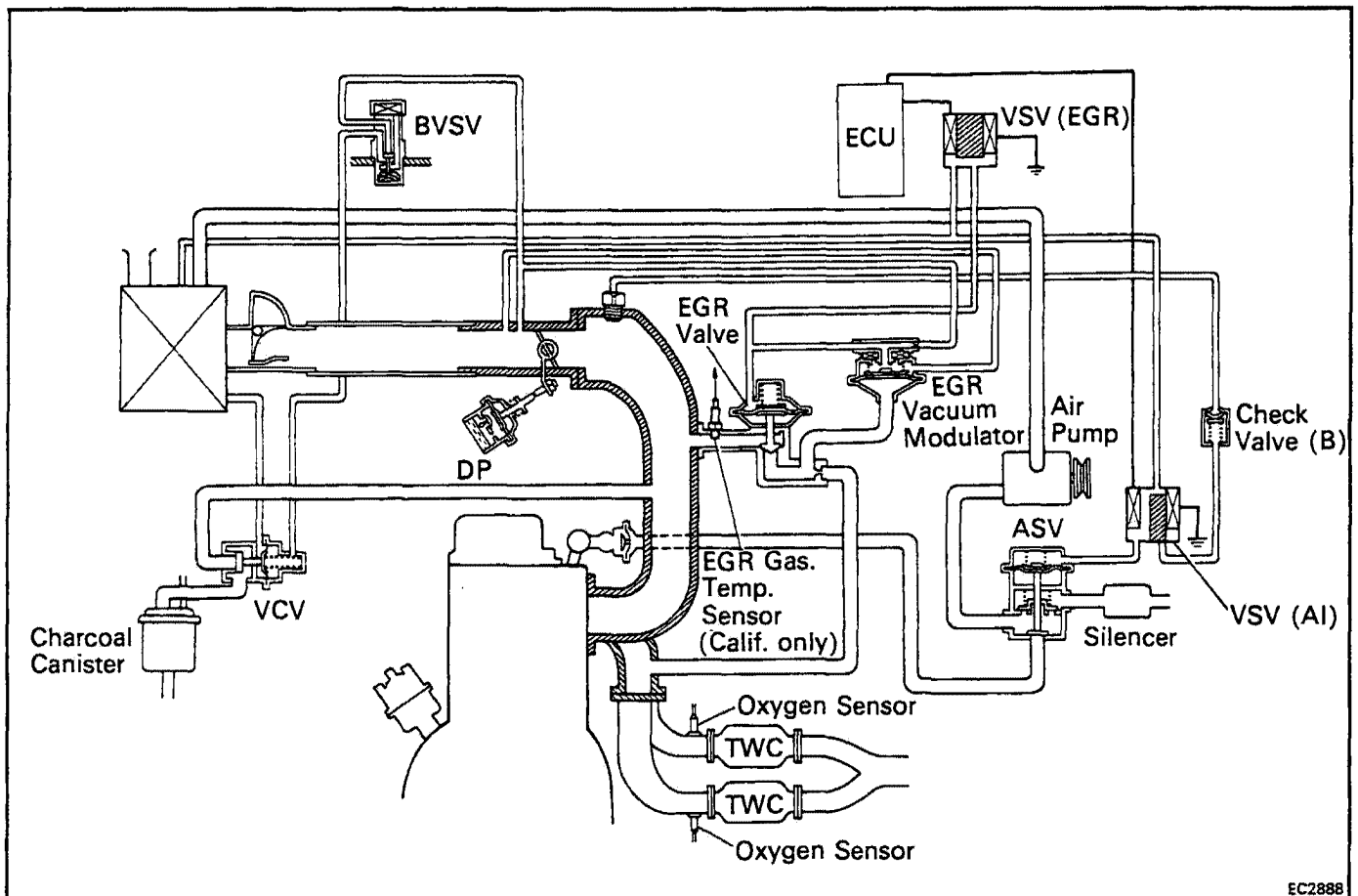
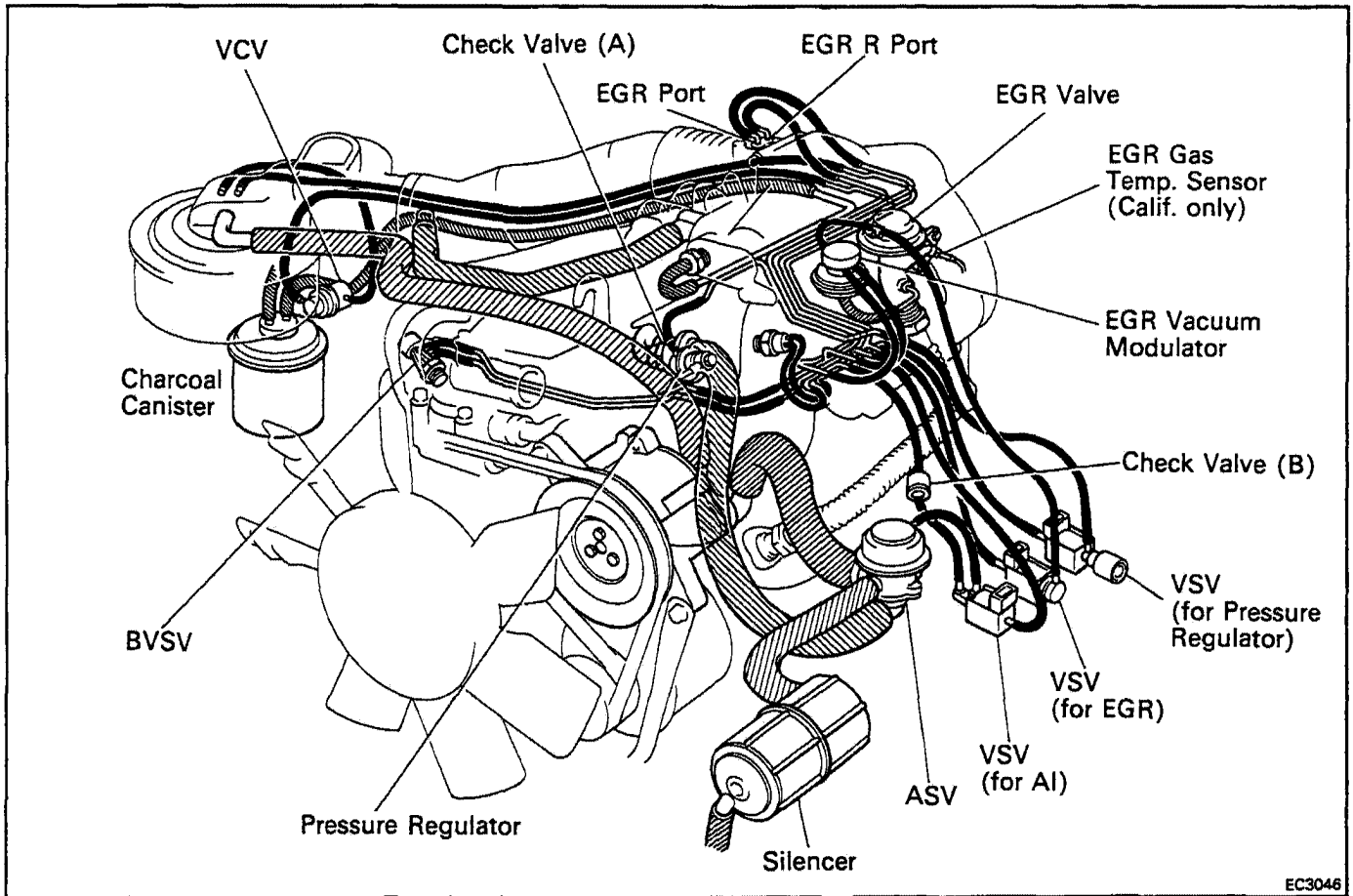

# POSITIVE CRANKCASE VENTILATION (PCV) SYSTEM

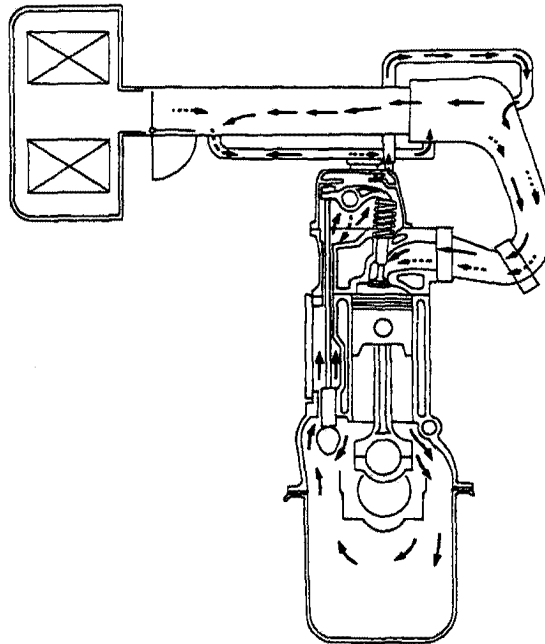

————→ Blow-by Gas  
 - - - - -> Fresh Air

EC3078

To reduce HC emissions, crankcase blow-by gas (HC) is routed through the PCV valve to the intake manifold for combustion in the cylinders.

**Engine not Running or Backfiring**  
 Intake Manifold Side

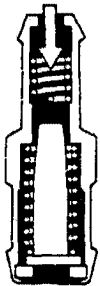

- PCV VALVE IS CLOSED.

Cylinder Head Side

EC1007

**Normal Operation**



- PCV VALVE IS OPEN.
- VACUUM PASSAGE IS LARGE.

EC1009

**Idling or Decelerating**



- PCV VALVE IS OPEN
- VACUUM PASSAGE IS SMALL.

EC1008

**Acceleration or High Load**

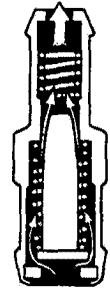

- PCV VALVE IS FULLY OPEN.

EC1010

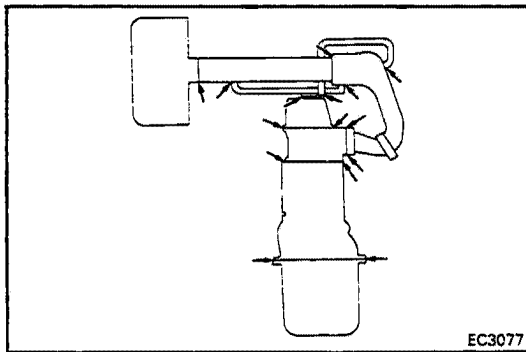
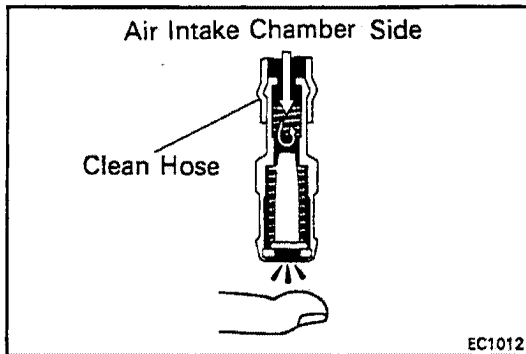
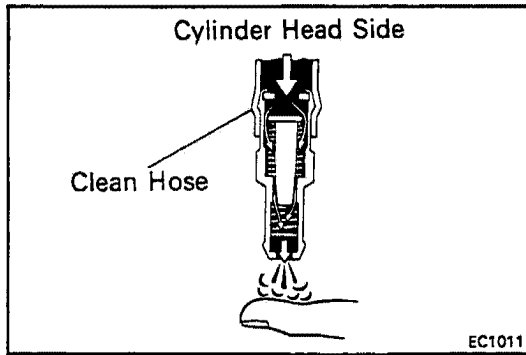

## INSPECTION OF PCV VALVE

1. REMOVE PCV VALVE
2. ATTACH CLEAN HOSE TO PCV VALVE
3. BLOW FROM CYLINDER HEAD SIDE

Check that air passes through easily.

**CAUTION:** Do not suck air through the valve. Petroleum substances inside the valve are harmful.

4. BLOW FROM AIR INTAKE CHAMBER SIDE  
Check that air passes through with difficulty.  
If the PCV valve fails either of the checks, replace it.
5. REINSTALL PCV VALVE

## INSPECTION OF PCV HOSES AND CONNECTIONS

### VISUALLY INSPECT HOSES, CONNECTIONS AND GASKETS

Check for cracks, leaks or damage.

# FUEL EVAPORATIVE EMISSION CONTROL (EVAP) SYSTEM

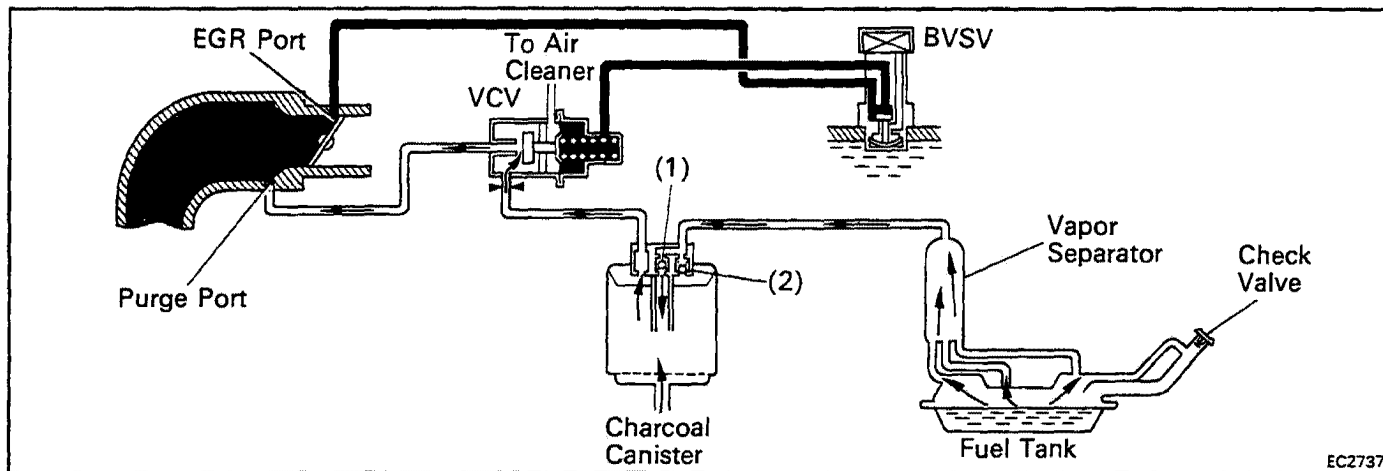

EC2737

To reduce HC emission, evaporated fuel from the fuel tank is routed through the charcoal canister to the intake manifold for combustion in the cylinders.

Coolant Temp.	BVSV	Vacuum at EGR Port	VCV	Check Valve		Check Valve in Cap	Evaporated Fuel (HC)
				(1)	(2)		
Below 45°C (151°F)	CLOSED	—	CLOSED	—	—	—	HC from tank is absorbed into the canister.
Above 64°C (147°F)	OPEN	Blow 50 mmHg. (1.97 in.Hg)	CLOSED	—	—	—	
		Above 70 mmHg. (2.76 in.Hg)	OPEN	—	—	—	CH from canister is led into air intake chamber.
High pressure in tank	—	—	—	OPEN	CLOSED	CLOSED	HC from tank is absorbed into the canister.
High vacuum in tank	—	—	—	CLOSED	OPEN	OPEN	Air is led into the fuel tank.

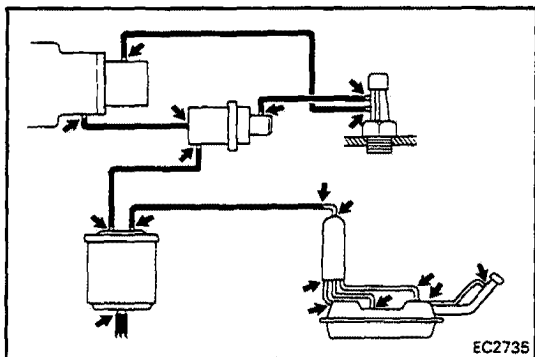

EC2735

## INSPECTION OF FUEL VAPOR LINES, FUEL TANK AND TANK CAP

### 1. VISUALLY INSPECT LINES AND CONNECTIONS

Look for loose connections, sharp bends or damage.

### 2. VISUALLY INSPECT FUEL TANK

Look for deformation, cracks or fuel leakage.

### 3. VISUALLY INSPECT FUEL TANK CAP

- Remove the four screws and retainer.
- Look for a damaged or deformed gasket.
- Reinstall the retainer.

If necessary, repair or replace the cap.

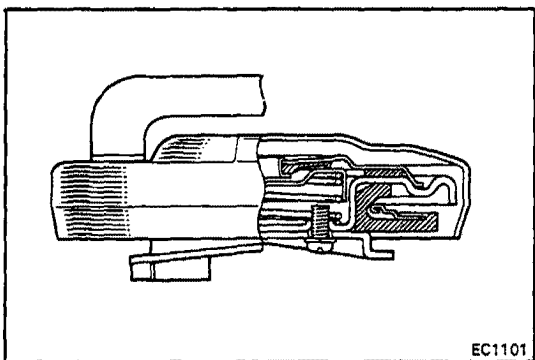

EC1101

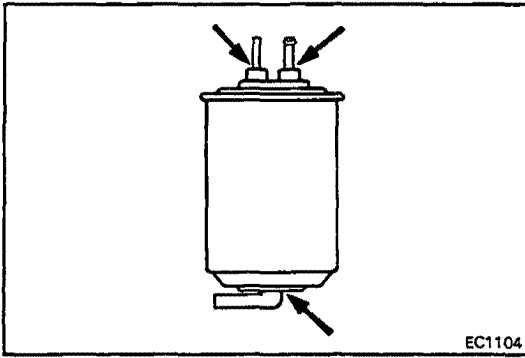

## INSPECTION OF CHARCOAL CANISTER

1. REMOVE CHARCOAL CANISTER
2. VISUALLY INSPECT CHARCOAL CANISTER CASE

Look for cracks or damage.

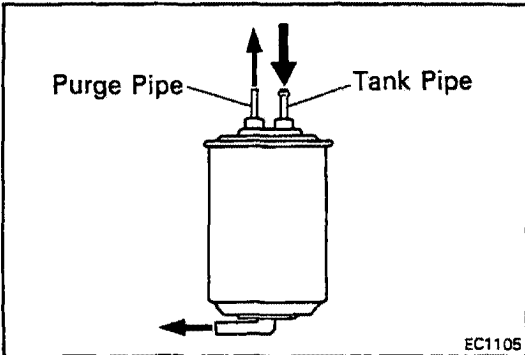

3. CHECK FOR CLOGGED FILTER AND STUCK CHECK VALVE

- (a) Using low pressure compressed air, blow into the tank pipe and check that the air flows without resistance from the other pipes.
- (b) Blow into the purge pipe and check that the air does not flow from the other pipes.

If a problem is found, replace the charcoal canister.

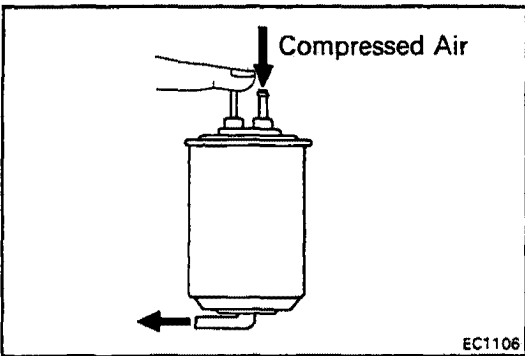

4. CLEAN FILTER IN CANISTER

Clean the filter by blowing 3 kg/cm<sup>2</sup> (43 psi, 294 kPa) of compressed air into the tank pipe, while holding the other upper canister pipe closed.

NOTE:

- Do not attempt to wash the canister.
- No activated carbon should come out.

5. INSTALL CHARCOAL CANISTER

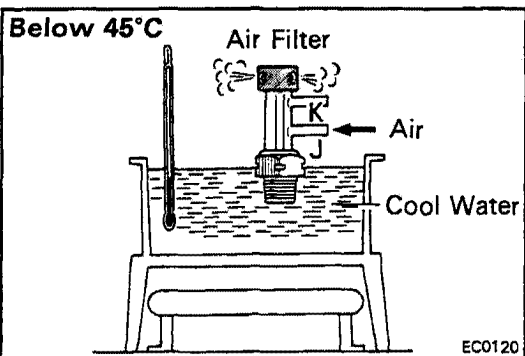

## INSPECTION OF BVSV

### CHECK BVSV BY BLOWING AIR INTO PIPE

- (a) Drain the coolant from the radiator into a suitable container.
- (b) Remove the BVSV from the water outlet.
- (c) Cool the BVSV to below 45°C (113°F) with cool water.
- (d) Check that that air flows from pipe J to the air filter.
- (e) Heat the BVSV to above 64°C (147°F) with hot water.

- (f) Check that air flows from pipe J to pipe K.

If a problem is found, replace the BVSV.

- (g) Apply sealant to the threads of the BVSV and re-install.

**Sealant: Part No. 08833-00070, THREE BOND 1324 or equivalent**

- (h) Fill the radiator with coolant.

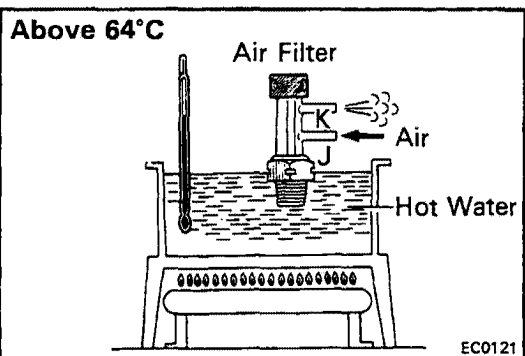

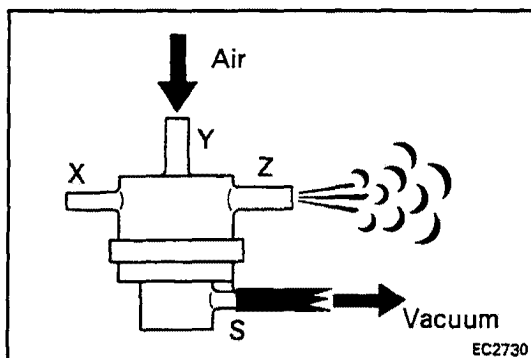

## INSPECTION OF VCV

### CHECK VCV BY BLOWING AIR INTO PIPE

- (a) Apply vacuum above 70 mmHg (2.76 in.Hg) to pipe S.
- (b) Blow air into pipe Y and check that air comes out of pipe Z.

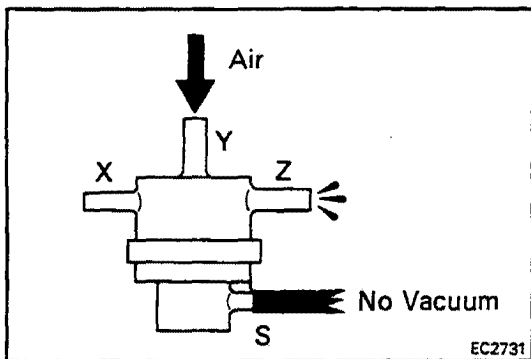

- (c) Stop the applied vacuum.
- (d) Blow air into pipe Y and check that air does not come out of pipe Z.

If a problem is found, replace the VCV.

# DASH POT (DP) SYSTEM

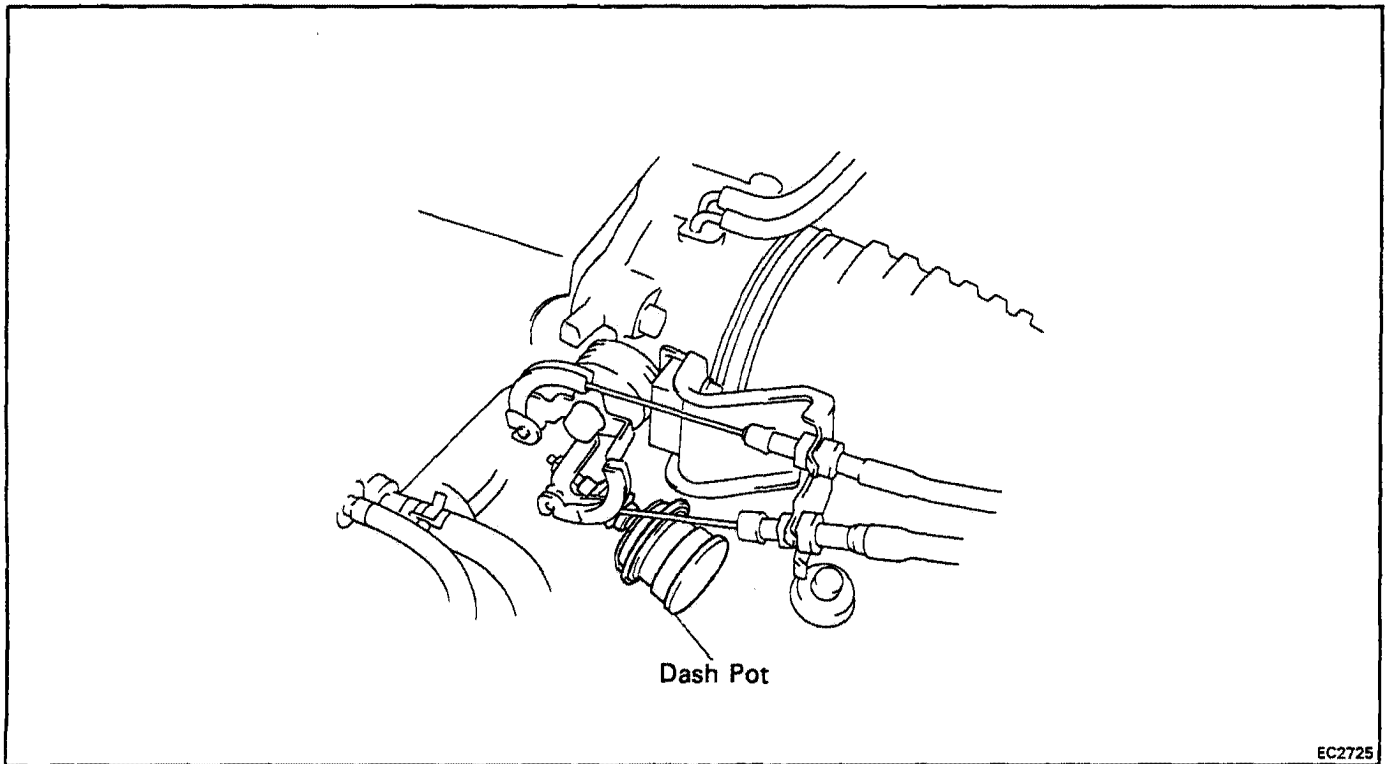

EC2725

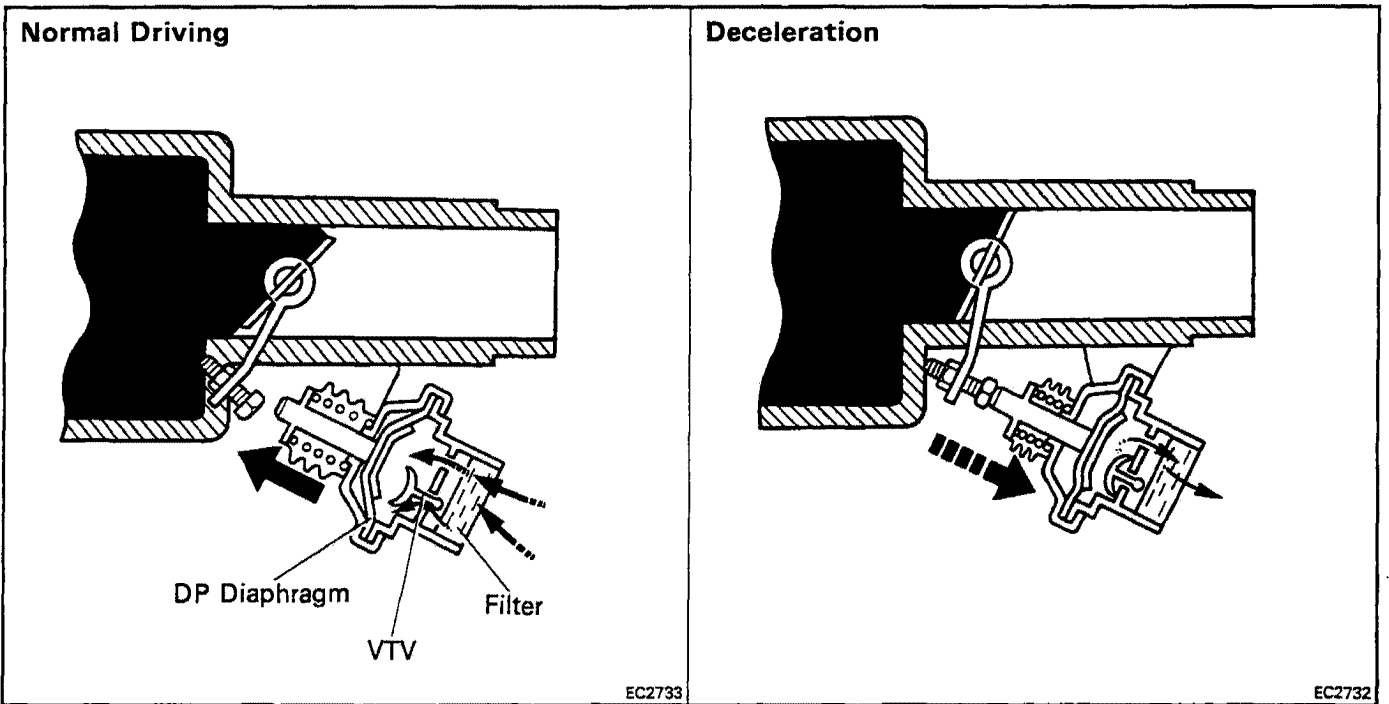

EC2733

EC2732

To reduce HC and CO emissions, when decelerating the dash pot opens the throttle valve slightly more than at idle. This causes the air-fuel mixture to burn completely.

Condition	Diaphragm	VTV	Throttle Valve
Idling	Pushed in by return force of throttle valve	CLOSED	Idle speed position
Normal driving	Pushed out by diaphragm spring	OPEN	High speed position
Deceleration	Pushed in by return force of throttle valve	CLOSED	Slightly opens and then slowly closes to idle position

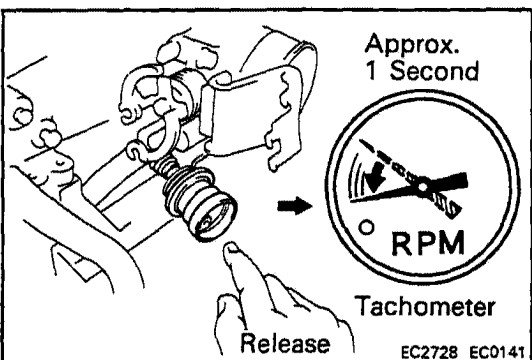
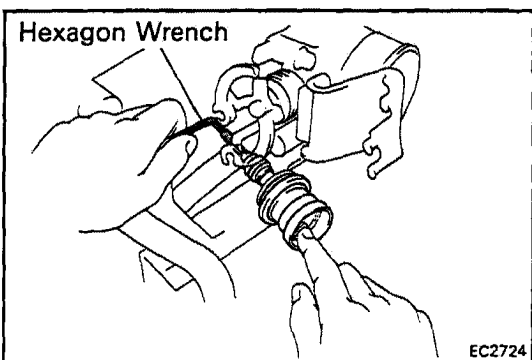
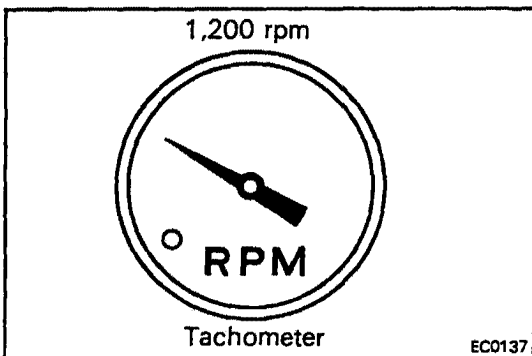
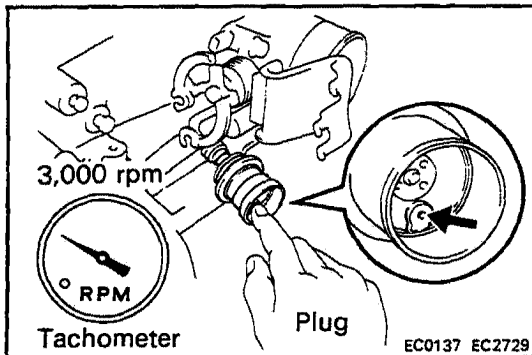
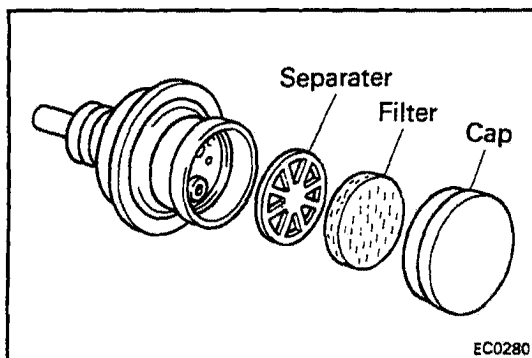

## INSPECTION OF DP SYSTEM

1. WARM UP ENGINE
2. CHECK IDLE SPEED
3. DISCONNECT ISC CONNECTOR
3. REMOVE CAP, FILTER AND SEPARATER FROM DP
5. CHECK DP SETTING SPEED
  - (a) Maintain engine speed at 2,500 rpm.
  - (b) Plug the VTV hole with your finger.
  - (c) Release the throttle valve.
  - (d) Check that the DP is set.

**DP setting speed: 1,200 rpm.**

If not as specified, adjust with the DP adjusting screw.

6. CHECK OPERATION OF VTV
  - (a) Set the DP speed in the same procedure as above; (a) to (c).
  - (b) Release the plugged hole and check that the engine returns to idle in approx.1 second.
7. REINSTALL DP SEPARATER, FILTER AND CAP
8. RECONNECT ISC CONNECTOR

# EXHAUST GAS RECIRCULATION (EGR) SYSTEM

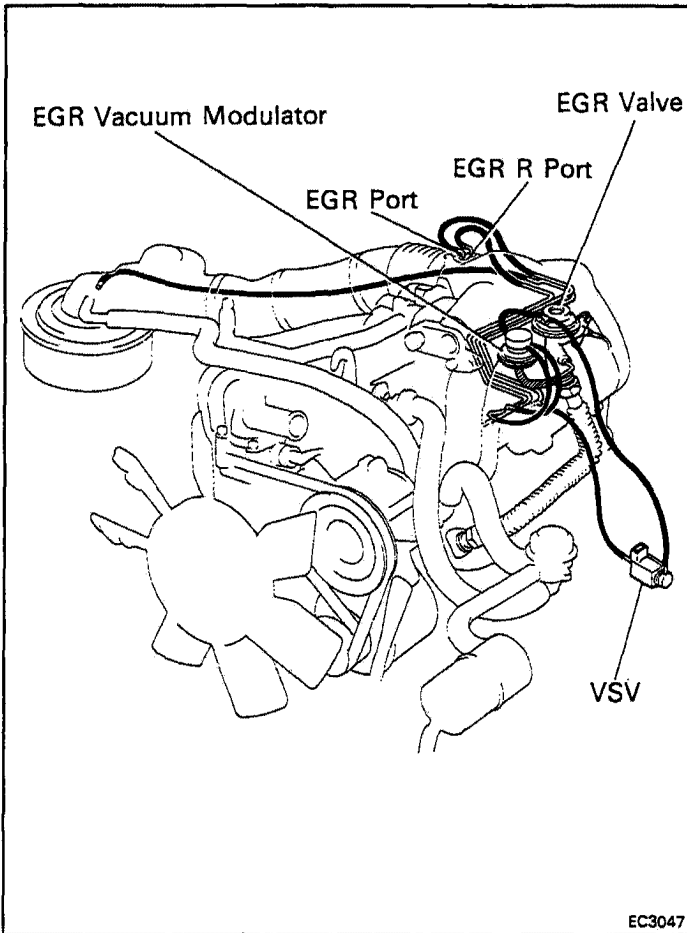

EC3047

(1)

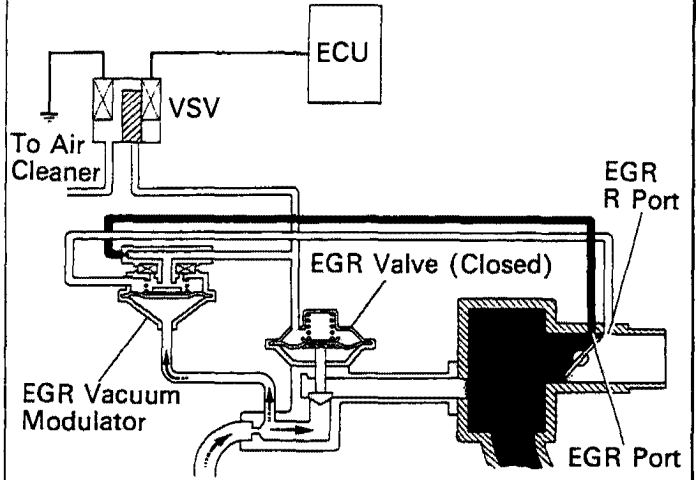

EC2931

(2)

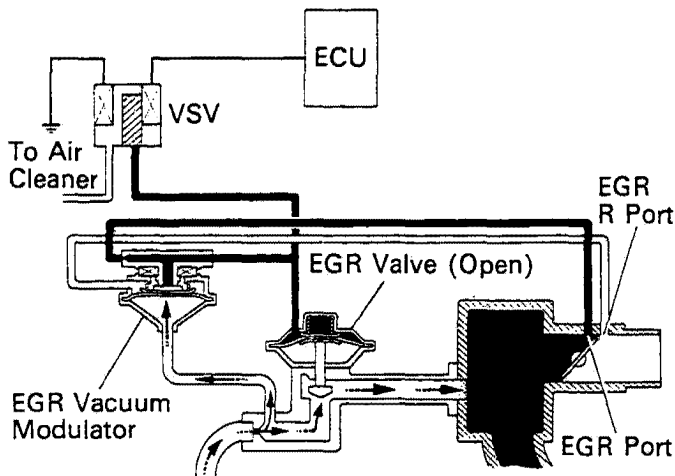

EC2932

(3)

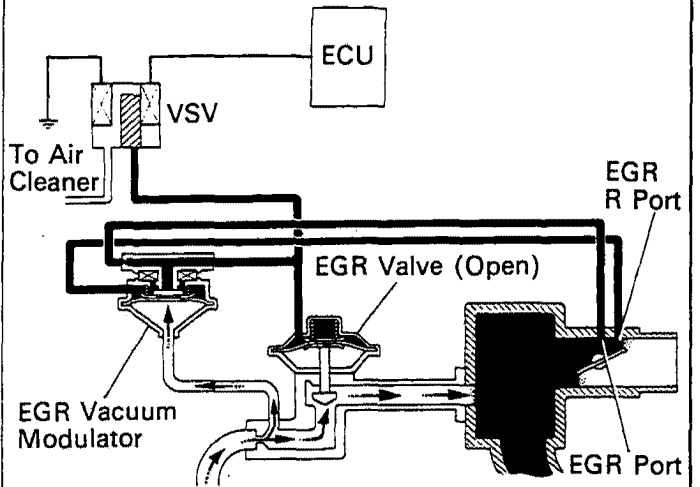

EC2933

To reduce NOx emission, part of the exhaust gases are recirculated through the EGR valve to the intake manifold to lower the maximum combustion temperature.

Coolant Temp.	Engine RPM	Driving Condition	Intake Air Volume	VSV	Throttle Valve Opening Angle	Pressure in the EGR Valve Pressure Chamber		EGR Vacuum Modulator	EGR Valve	Exhaust Gas
Below 47°C (117°F)	—	—	—	OFF	—	—		—	CLOSED	Not recirculated
Above 53°C (127°F)	Above 3,500 rpm	—	—	OFF	—	—		—	CLOSED	Not recirculated
	Blow 3,500 rpm	Deceleration	—	OFF	—	—		—	CLOSED	Not recirculated
		Ex. deceleration	LOW	OFF	—	—		—	CLOSED	Not recirculated
			HIGH	OFF	—	—		—	CLOSED	Not recirculated
				ON	Positioned below EGR port	—		—	CLOSED	Not recirculated
		HIGH	ON	Positioned between EGR port and EGR R port	(1) LOW	*Pressure constantly alternating between low and high	OPENS passage to atmosphere	CLOSED	Not recirculated	
	(2) HIGH				CLOSES passage to atmosphere		OPEN	Recirculated		
HIGH	ON	Positioned above EGR port	(3) HIGH	**	CLOSES passage to atmosphere	OPEN	Recirculated (increase)			

\* Pressure increase → Modulator closes → EGR valve opens → Pressure drops  
 ← EGR valve closes ← Modulator opens ←

\*\* When the throttle valve is positioned above the R port, the EGR vacuum modulator will close the atmosphere passage and open the EGR valve to increase the EGR gas, even if the exhaust pressure is insufficiently low.

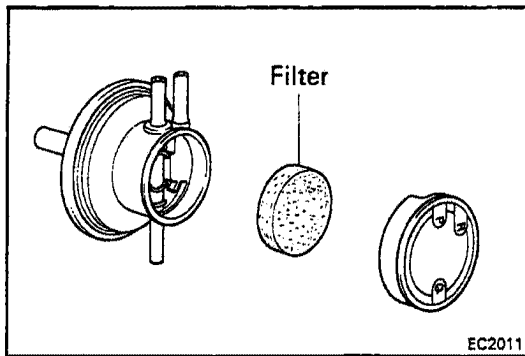

## INSPECTION OF EGR SYSTEM

### 1. CHECK AND CLEAN FILTER IN EGR VACUUM MODULATOR

- (a) Check the filter for contamination or damage.
- (b) Using compressed air, clean the filter.

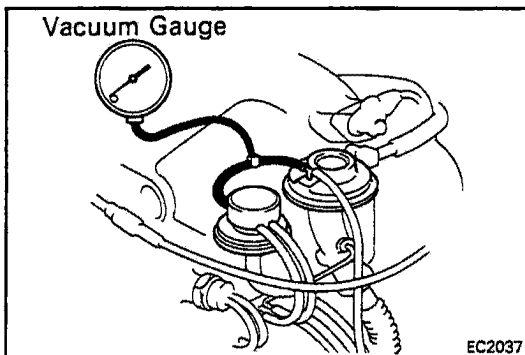

### 2. PREPARATION

Using a 3-way connector, connect a vacuum gauge to the hose between the EGR valve and vacuum pipe.

### 3. CHECK SEATING OF EGR VALVE

Start the engine and check that the engine starts and runs at idle.

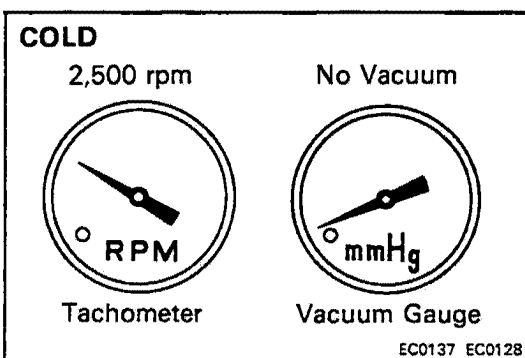

### 4. CHECK VSV WITH COLD ENGINE

- (a) The coolant temperature should be below 53°C (127°F).
- (b) Check that the vacuum gauge indicates zero at 2,500 rpm.

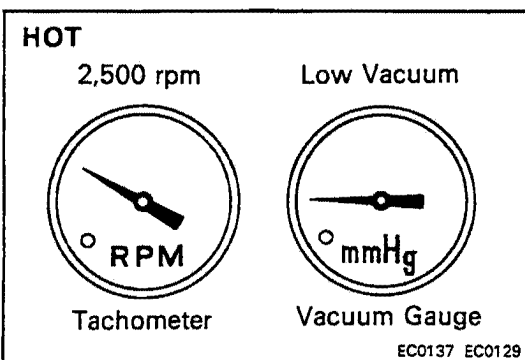

### 5. CHECK VSV AND EGR VACUUM MODULATOR WITH HOT ENGINE

- (a) Warm up the engine.
- (b) Check that the vacuum gauge indicates low vacuum at 2,500 rpm.
- (c) Check that the vacuum gauge indicates zero at idle.

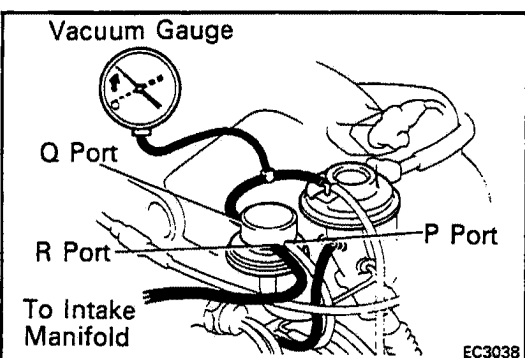

- (d) Disconnect the vacuum hose from port R of the EGR vacuum modulator and connect port R directly to the intake manifold with another hose.
- (e) Check that the vacuum gauge indicates high vacuum at 2,500 rpm.

**NOTE:** As a large amount of EGR gas enters, the engine will misfire slightly.

- (f) Remove the vacuum gauge and reconnect the vacuum hoses to the proper locations.

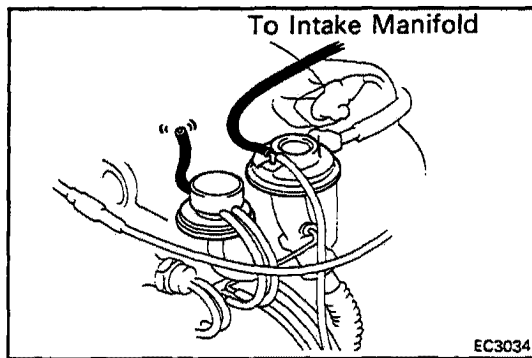

## 6. CHECK EGR VALVE

- Apply vacuum directly to the EGR valve with the engine idling.
- Check that the engine runs rough or dies.
- Reconnect the vacuum hoses to the proper location.

**IF NO PROBLEM IS FOUND WITH THIS INSPECTION, THE SYSTEM IS OKAY; OTHERWISE INSPECT EACH PART**

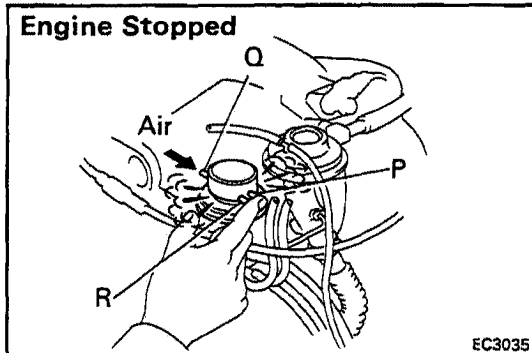

## INSPECTION OF EGR VACUUM MODULATOR

### CHECK EGR VACUUM MODULATOR OPERATION

- Disconnect the vacuum hoses from ports P, Q and R of the EGR vacuum modulator.
- Block ports P and R with your finger.
- Blow air into port Q. Check that the air passes through to the air filter side freely.
- Start the engine and maintain speed at 2,500 rpm.
- Repeat the above test. Check that there is a strong resistance to air flow.
- Reconnect the vacuum hoses to the proper locations.

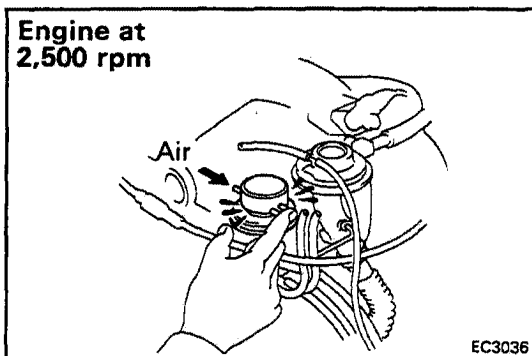

## INSPECTION OF VSV

### INSPECT VSV

- Blow air into a pipe and check that the VSV is open.

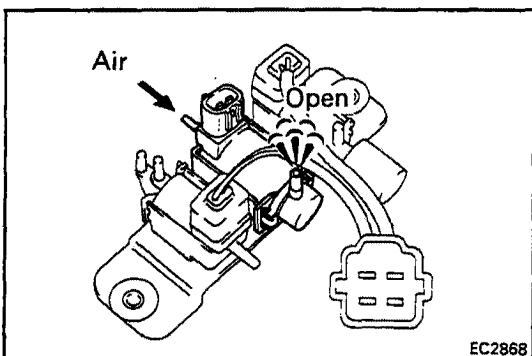

- Apply battery voltage across the terminals.
  - Blow air into pipe and check that the VSV is closed.
- If a problem is found, replace the VSV.

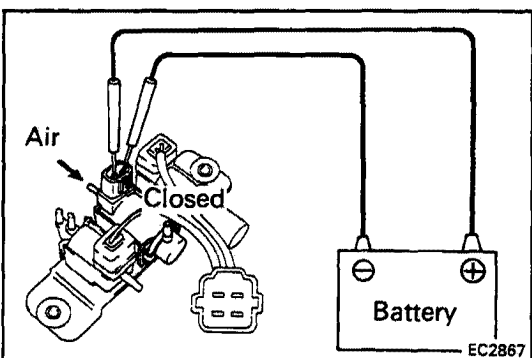

## **INSPECTION OF EGR VALVE**

### **1. REMOVE EGR VALVE**

Check the valve for sticking and heavy carbon deposits.  
If a problem is found, replace it.

### **2. REINSTALL EGR VALVE WITH NEW GASKET**

## **INSPECTION OF WATER TEMPERATURE SENSOR**

(See page FI-77)

## **INSPECTION OF THROTTLE POSITION SENSOR**

(See page FI-68)

## **INSPECTION OF AIR FLOW METER**

(See page FI-66)

# AIR INJECTION (AI) SYSTEM

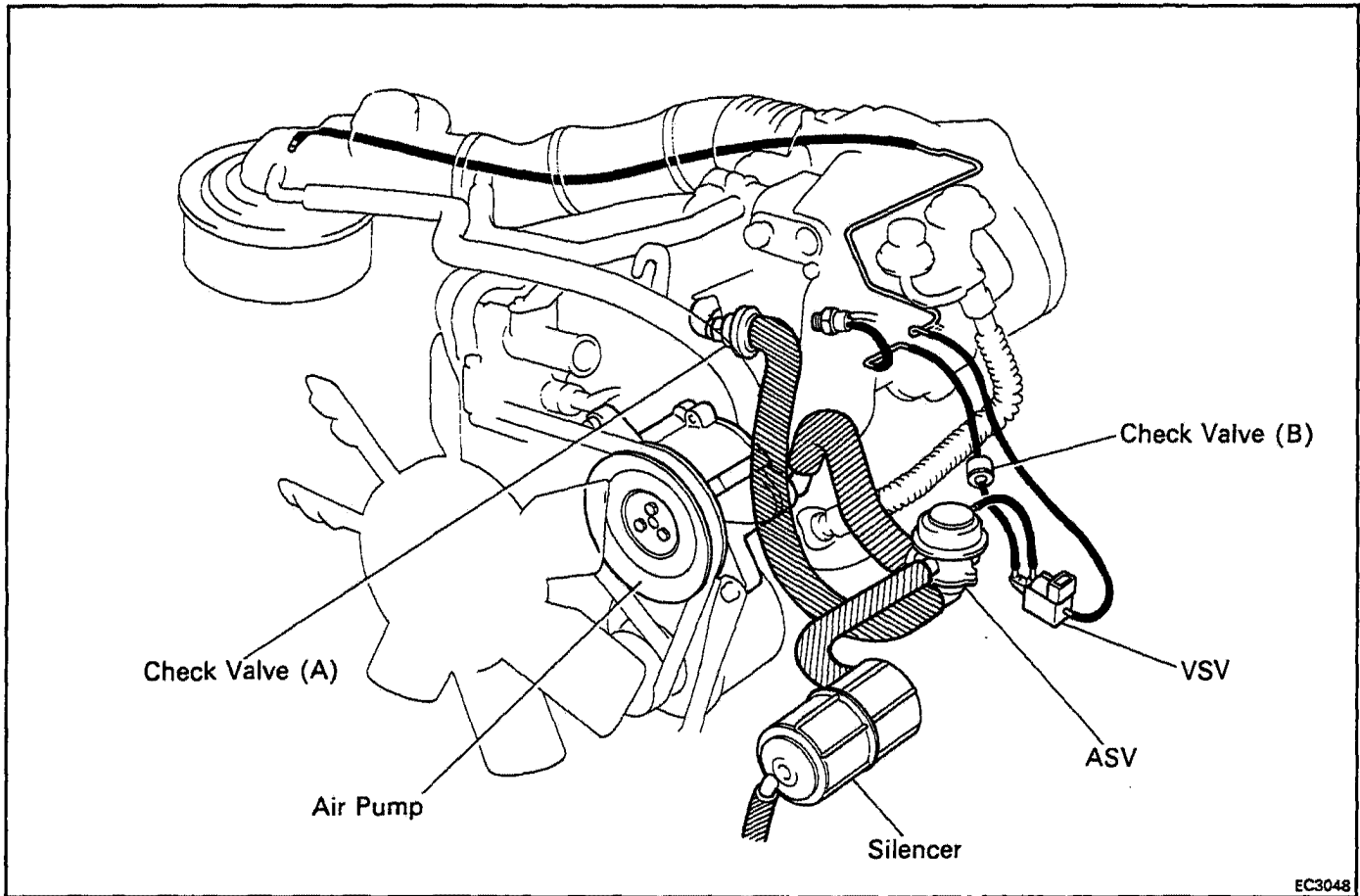

EC3048

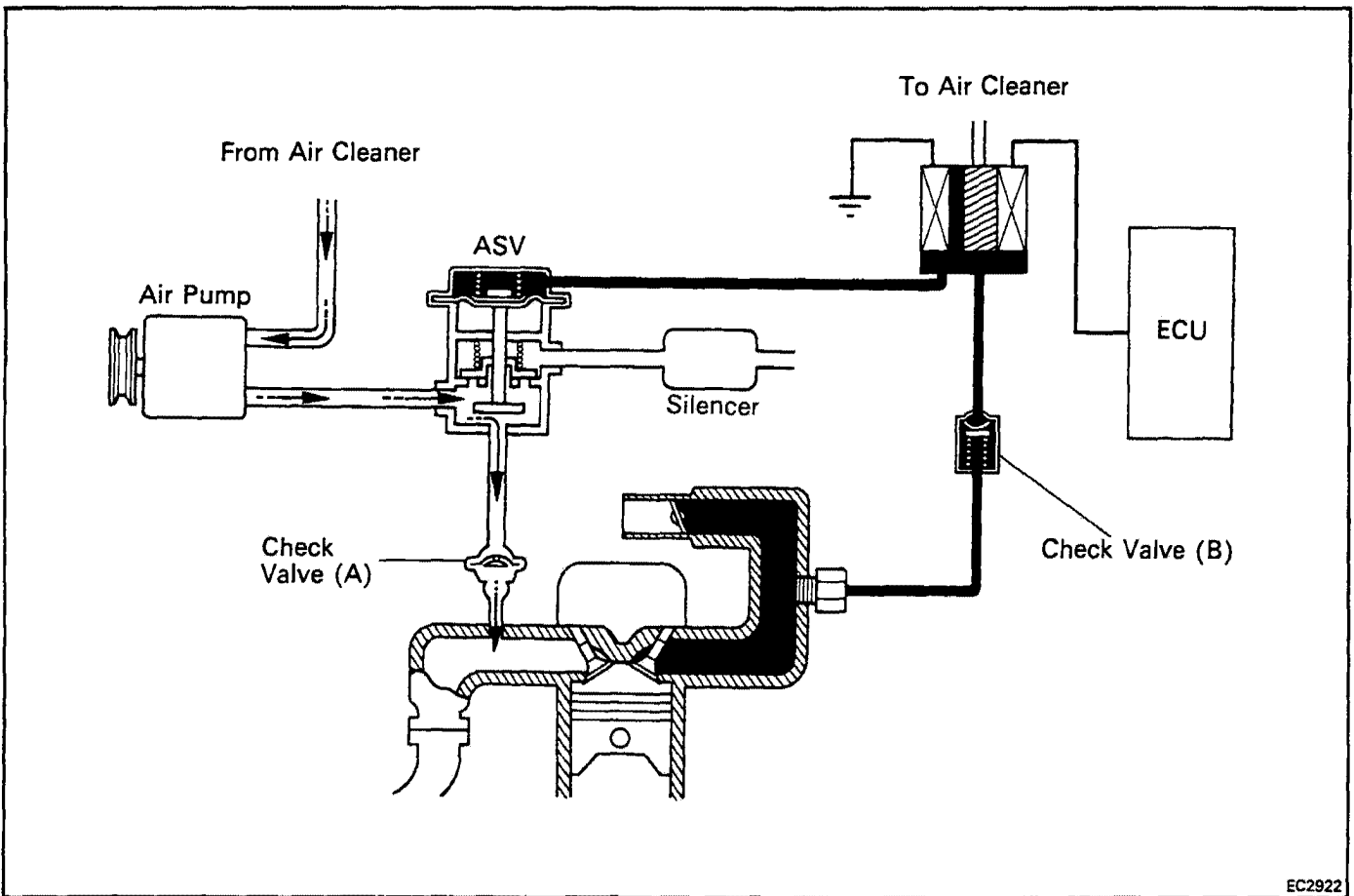

EC2922

For reburning the unburnt HC and CO in the exhaust port, compressed air from the air pump is blown into the exhaust port.

Coolant Temp.	Driving Condition	Engine RPM	Vehicle Speed	VSV	ASV	AI System
Blow 10°C (50°F)	—	—	—	OFF	CLOSED	OFF
Between 15 – 35°C (59 – 95°F)	—	—	—	ON	OPEN	ON
Above 40°C (104°F)	Ex. deceleration	—	—	OFF	CLOSED	OFF
	Deceleration	Above 2,000 rpm	—	OFF	CLOSED	OFF
		Blow 2,000 rpm	Above 6 mph (10 km/h)	—	ON	OPEN

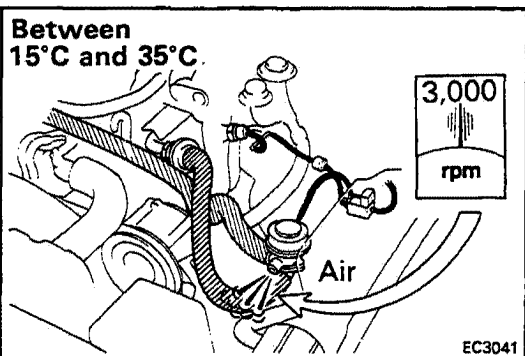
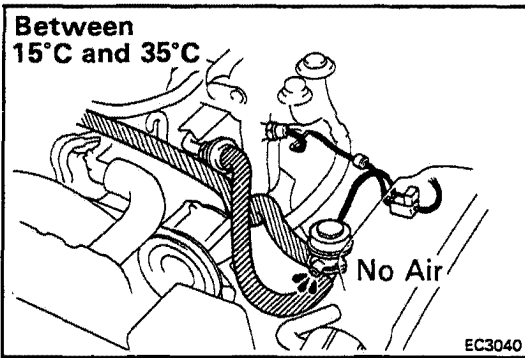
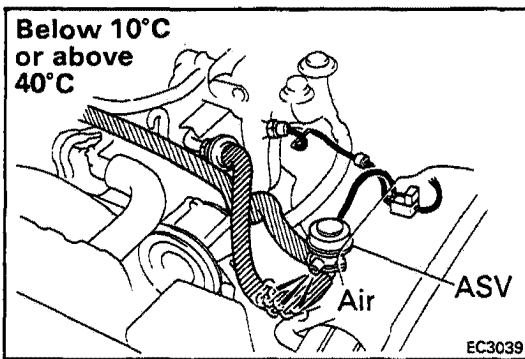

### INSPECTION OF AI SYSTEM

1. VISUALLY CHECK HOSES AND TUBES FOR CRACKS, KINKS, DAMAGE OR LOOSE CONNECTIONS

2. PREPARATION

Disconnect the air by-pass hose from the ASV.

3. CHECK ASV WITH FOLLOWING TEMPERATURE:

- (a) The coolant temperature should be below 10°C (50°F) or above 40°C (104°F).
- (b) Start the engine and check that air is discharged from the ASV.
- (c) The coolant temperature should be between 15°C (59°F) and 35°C (95°F).
- (d) With engine idling, check that air is not discharged from the ASV.

(e) The coolant temperature should be between 15°C (59°F) and 35°C (95°F).

(f) Increase the engine speed to 3,000 rpm and check that air is discharged from the ASV.

### INSPECTION OF AIR PUMP DRIVE BELT (See page MA-4)

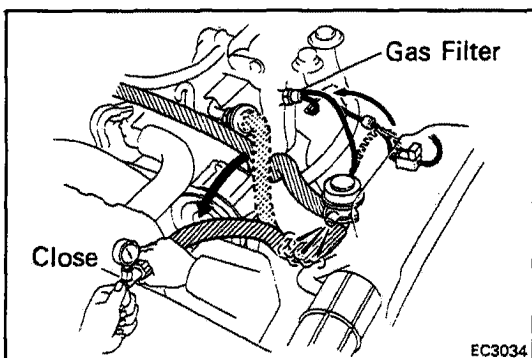
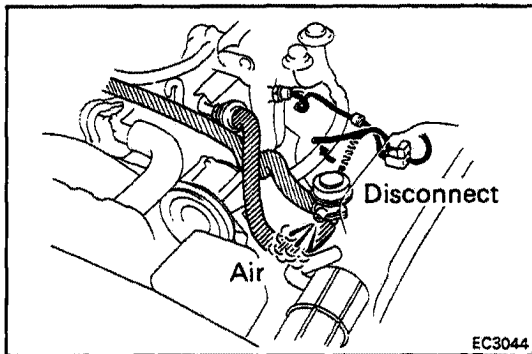
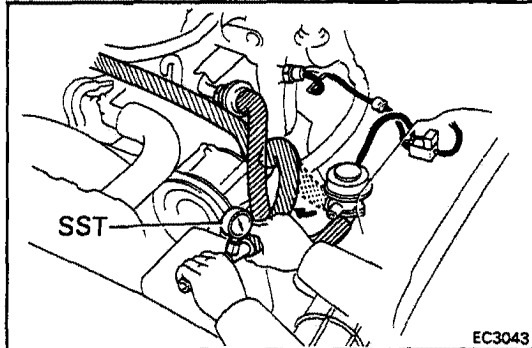
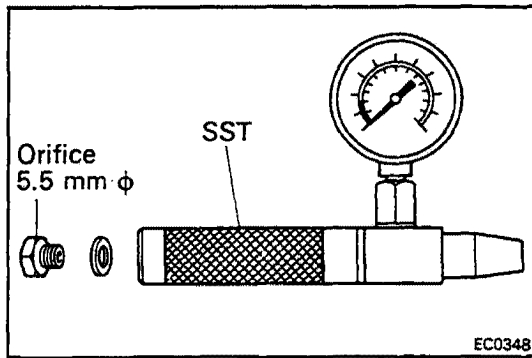

## INSPECTION OF AIR PUMP

1. CHECK AIR PUMP FOR ABNORMAL NOISE
2. CHECK AIR PUMP DISCHARGE PRESSURE

(a) Connect SST (air pump tester) to the hose at the air pump outlet.

SST 09258-14010

(b) Select and use a specified orifice (5.5 mm dia. or 0.217 in.) on the SST.

(c) Set the engine speed at 1,200 rpm.

(d) The gauge of the SST should indicate in the green zone.

If the SST indicates in the red zone, replace the pump assembly.

(e) Reconnect the hose to the proper location.

## INSPECTION OF ASV

1. CHECK ASV OPERATION

(a) Disconnect the vacuum hose from the ASV.

(b) Check that air comes out from the ASV.

2. CHECK OPENING PRESSURE OF RELIEF VALVE

(a) Disconnect the air hose from the check valve.

(b) Connect SST (air pump tester) to the hose.

SST 09258-14010

(c) Disconnect the vacuum hose from the VSV and connect the vacuum hose to the gas filter.

(d) Close the orifice on the SST with your finger.

(e) Increase the engine speed gradually and measure the relief valve opening pressure.

**Opening pressure: 0.40 – 0.60 kg/cm<sup>2</sup>  
(5.7 – 8.5 psi, 39 – 59 kPa)**

(f) Remove the SST and reconnect the hose to the proper location.

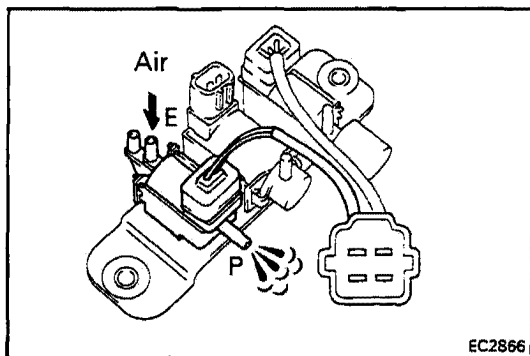

## INSPECTION OF VSV

### INSPECT VSV

- (a) Blow air into pipe E and check that air comes out of pipe P.

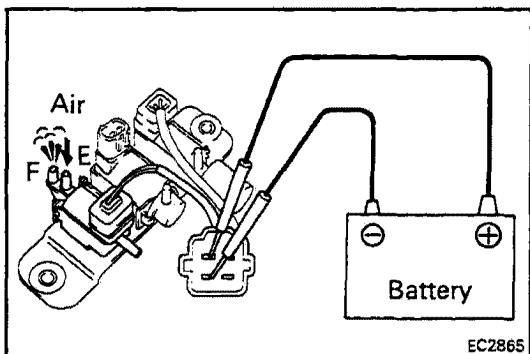

- (b) Apply battery voltage across the terminals.
- (c) Blow air into pipe E and check that air comes out of pipe F.

If a problem is found, replace the VSV.

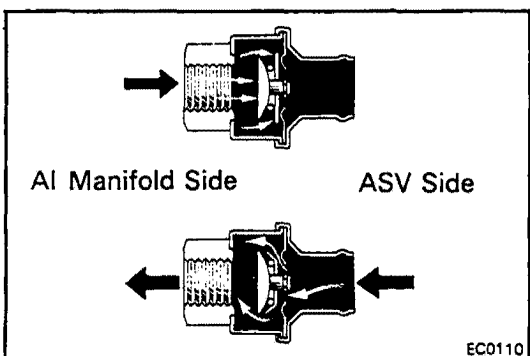

## INSPECTION OF CHECK VALVE (A)

### CHECK VALVE BY BLOWING AIR FROM EACH SIDE

- (a) Check that air does not flow from manifold side to ASV side.
- (b) Check that air flows from ASV side to manifold side.

If a problem is found, replace the valve.

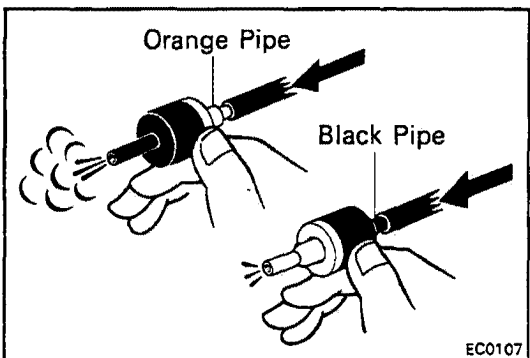

## INSPECTION OF CHECK VALVE (B)

### CHECK VALVE BY BLOWING AIR FROM EACH SIDE

- (a) Check that air flows from the orange pipe to the black side.
- (b) Check that air does not flow from the black pipe to the orange pipe.

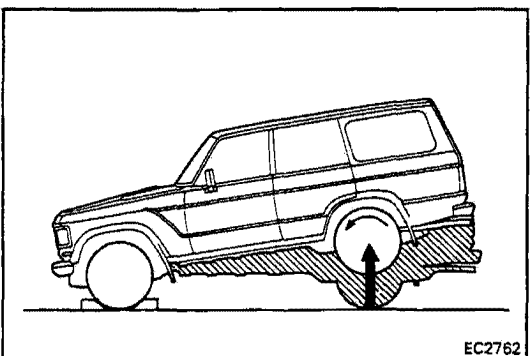

## INSPECTION OF SPEED SENSOR

1. JACK UP ONE REAR WHEEL TO CLEAR GROUND AND CHOCK FRONT WHEELS
2. RELEASE PARKING BRAKE
3. SET SHIFT LEVER INTO NEUTRAL
4. UNPLUG WIRING CONNECTOR FROM EFI ECU  
EFI ECU location: Behind the glove box

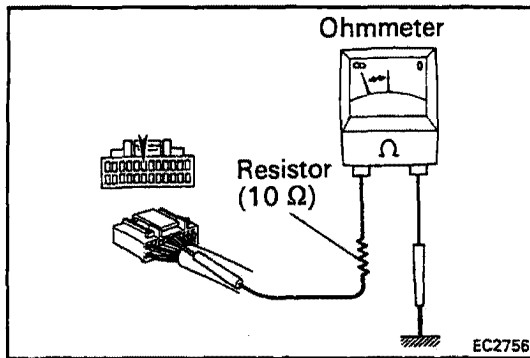

## 5. CHECK ON-OFF CYCLES OF SPEED SENSOR

- Place the positive (+) terminal of the ohmmeter on the wiring connector terminal and the negative (-) terminal on ground.
- Turn the rear wheel.
- Check that the ohmmeter needle deflects consistently.

**CAUTION:** The ohmmeter probe should be inserted from the rear side of the connector.

If the ohmmeter needle does not deflect, check that the speed sensor terminals at the back side of the speedometer air properly connected. If the connection is OK, replace the speedometer assembly.

## 6. RECONNECT WIRING CONNECTOR TO COMPUTER

## INSPECTION OF WATER TEMPERATURE SENSOR

(See page FI-77)

## INSPECTION OF THROTTLE POSITION SENSOR

(See page FI-68)

## INSPECTION OF AIR FLOW METER

(See page FI-66)

# THREE-WAY CATALYST(TWC) SYSTEM

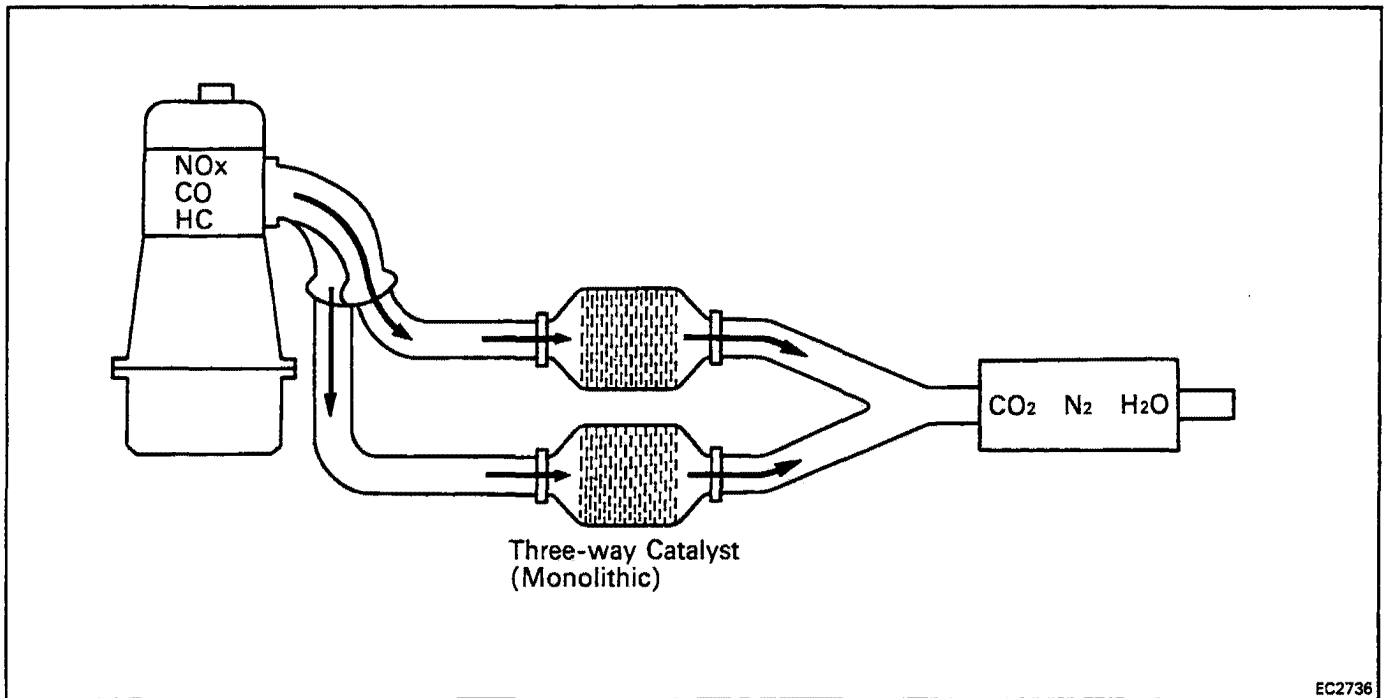

To reduce HC, CO and NOx emissions, they are oxidized, reduced and converted to nitrogen (N<sub>2</sub>), carbon dioxide (CO<sub>2</sub>) and water (H<sub>2</sub>O) by the catalyst.

Exhaust Port	TWC	Exhaust Gas
HC, CO and NOx	Oxidation and reduction	CO <sub>2</sub> H <sub>2</sub> O N <sub>2</sub>

## INSPECTION OF EXHAUST PIPE ASSEMBLY

1. CHECK CONNECTIONS FOR LOOSENESS OR DAMAGE
2. CHECK CLAMPS FOR WEAKNESS, CRACKS OR DAMAGE

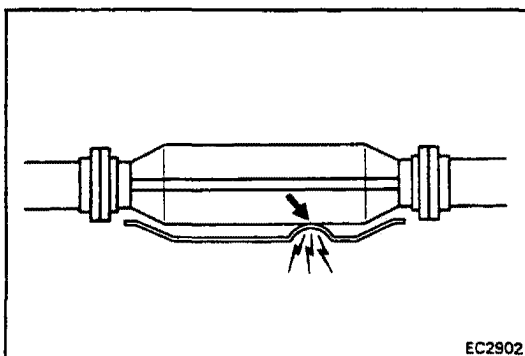

## INSPECTION OF CATALYST CONVERTER CHECK FOR DENTS OR DAMAGE

If any part of the protector is damaged or dented to the extent that it contacts the catalyst, repair or replace it.

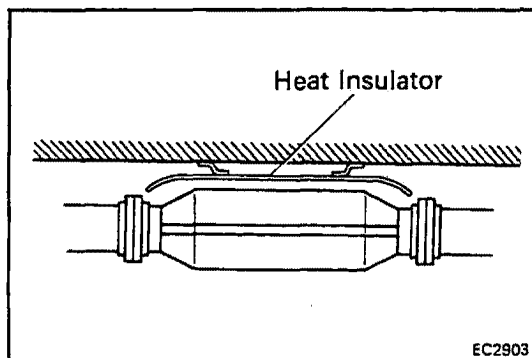

## INSPECTION OF HEAT INSULATOR

1. CHECK HEAT INSULATOR FOR DAMAGE
2. CHECK FOR ADEQUATE CLEARANCE BETWEEN CATALYTIC CONVERTER AND HEAT INSULATOR

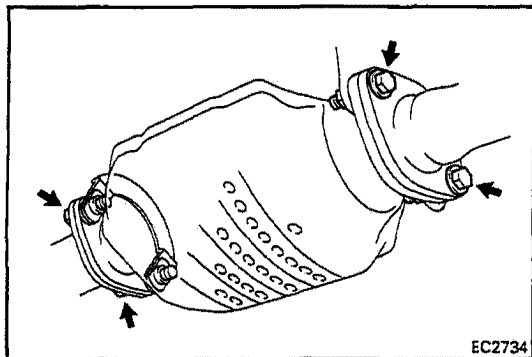

## REPLACEMENT OF CATALYTIC CONVERTER

1. REMOVE CONVERTER
  - (a) Jack up the vehicle.
  - (b) Check that the converter is cool.
  - (c) Remove the bolts at the front and rear of the converter.
  - (d) Remove the converter and gaskets.
2. INSTALL CONVERTER
  - (a) Place new gaskets on the converter front and rear pipes, and connect the converter to the exhaust pipes.
  - (b) Tighten the bolts.

**Torque: Catalyst - Exhaust pipe**  
**440 kg-cm (32 ft-lb, 43 N·m)**

  - (c) Reinstall the bracket bolts and tighten them.

# EFI SYSTEM

	Page
SYSTEM DESCRIPTION .....	FI-2
PRECAUTIONS .....	FI-4
INSPECTION PRECAUTIONS .....	FI-4
TROUBLESHOOTING .....	FI-9
DIAGNOSIS SYSTEM .....	FI-21
TROUBLESHOOTING WITH VOLT/OHMMETER .....	FI-27
FUEL SYSTEM .....	FI-46
Fuel Pump .....	FI-46
Cold Start Injector .....	FI-52
Fuel Pressure Regulator .....	FI-55
Injectors .....	FI-57
Fuel Tank and Lines .....	FI-64
AIR INDUCTION SYSTEM .....	FI-66
Air Flow Meter .....	FI-66
Throttle Body .....	FI-68
Idle Speed Control (ISC) Valve .....	FI-71
ELECTRONIC CONTROL SYSTEM .....	FI-73
Location of Electronic Control Parts .....	FI-73
EFI Main Relay .....	FI-74
Circuit Opening Relay .....	FI-75
Cold Start Injector Time Switch .....	FI-76
Water Temperature Sensor .....	FI-77
High Temperature Line Pressure Up System .....	FI-78
EGR Gas Temperature Sensor (California Vehicles only) .....	FI-79
Oxygen Sensors .....	FI-80
Electronic Controlled Unit (ECU) .....	FI-82
Fuel Cut RPM .....	FI-85

# SYSTEM DESCRIPTION

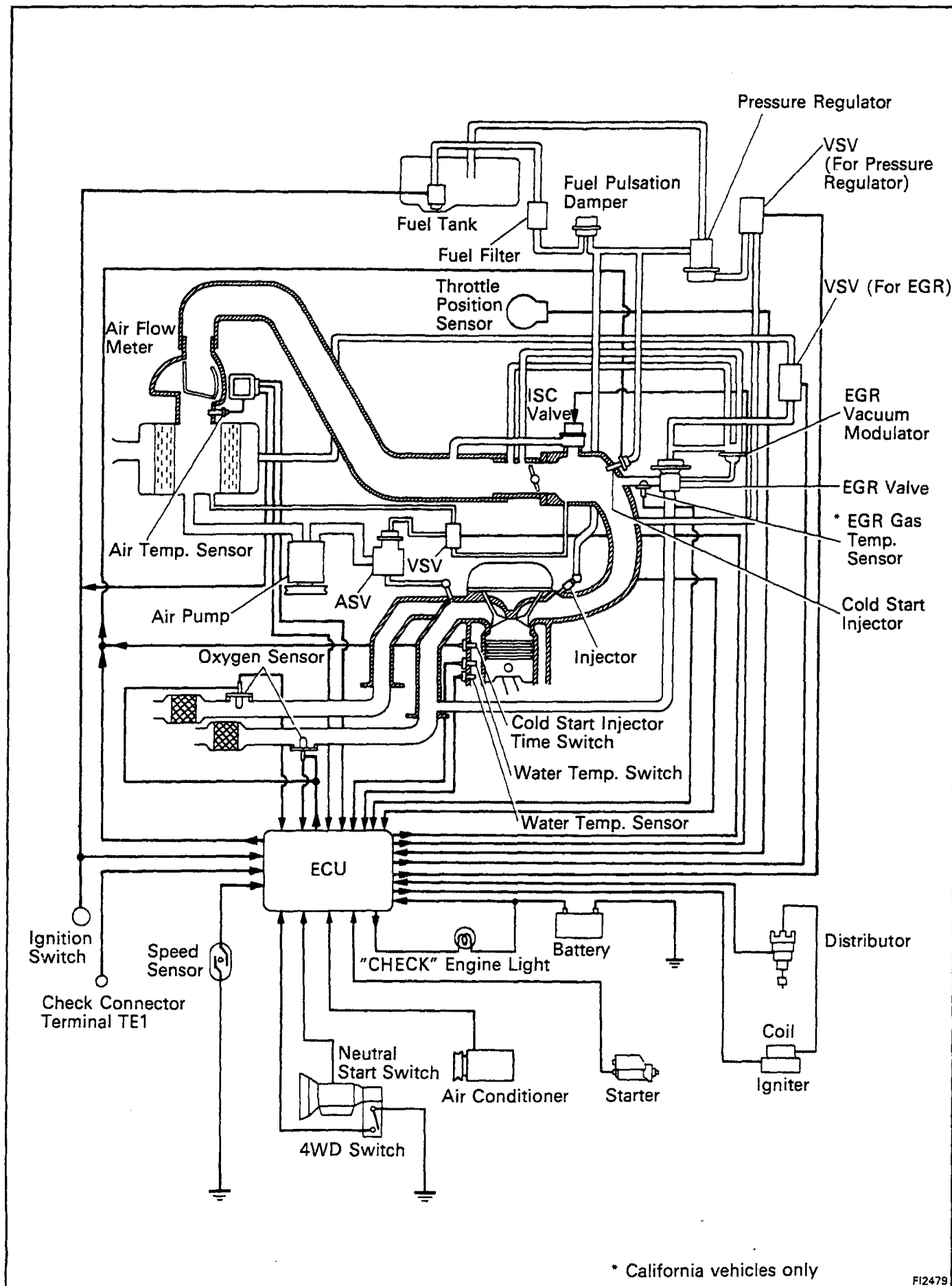

The EFI system is composed of three basic subsystems: Fuel Induction, Air Induction and Electronic Control Systems.

## FUEL SYSTEM

Fuel is supplied under constant pressure to the EFI injectors by an electric fuel pump. The injectors inject a metered quantity of fuel into the intake manifold in accordance with signals from the ECU (Electronic Control Unit).

## AIR INDUCTION SYSTEM

The air induction system provides sufficient air for engine operation.

## ELECTRONIC CONTROL SYSTEM

The 3F-E engine is equipped with a Toyota Computer Control System (TCCS) which centrally controls the EFI, ESA, ISC, Diagnosis systems, etc. by means of an Electronic Control Unit (ECU – formerly EFI computer) employing a microcomputer.

By means of the ECU, the TCCS controls the following functions:

### 1. Electronic Fuel Injection (EFI)

The ECU receives signals from various sensors indicating changing engine operating conditions such as:

- Intake air volume
- Intake air temperature
- Coolant temperature
- Engine rpm
- Acceleration / deceleration
- Exhaust oxygen content etc.

These signals are utilized by the ECU to determine the injection duration necessary for an optimum air-fuel ration.

### 2. Electronic Spark Advance (ESA)

The ECU is programmed with data for optimum ignition timing under any and all operating conditions. Using data provided by sensors which monitor various engine functions (rpm, coolant temperature, etc.), the microcomputer (ECU) triggers the spark at precisely the right instant. (See IG section)

### 3. Idle Speed Control (ISC)

The ECU is programmed with target idling speed values to respond to different engine conditions (coolant temperature, air conditioner on/off, etc.). Sensors transmit signals to the ECU which control the flow of air through the bypass of the throttle valve and adjust idle speed to the target value. (See pages FI-40, 71)

### 4. Exhaust Gas Recirculation (EGR)

The ECU controls the EGR system according a coolant temperature, engine rpm, throttle angle, vehicle speed and inlet air flow rate.

### 5. Air Injection (AI)

The ECU controls the AI system according to coolant temperature, engine rpm, throttle angle, vehicle speed and inlet air rate.

### 6. Diagnosis

The ECU detects any malfunctions or abnormalities in the sensor network and lights a "CHECK" engine warning light on the instrument panel. At the same time, the trouble is identified and a diagnostic code is recorded by the ECU. The diagnostic code can be read by the number of blinks of the "CHECK" engine warning light when terminals TE1 and E1 are short-circuited. The diagnostic codes are refer to the later page. (See pages FI-24, 25)

### 7. Fail-Safe Function

When an abnormality occurs in any of the ECU input signals, the ECU substitutes a standard valve stored in the microcomputer memory in order to prevent engine malfunction. Also, if the abnormality is serious, the ECU stops the engine.

### 8. Back-Up Function

Even when an abnormality occurs in the ECU provides regular fuel injection and control of the ignition timing to provide vehicle driveability.

## PRECAUTIONS

1. Before working on the fuel system, disconnect the cable from negative (–) terminal of the battery.

NOTE: Any diagnostic code retained by the computer will be erased when the battery terminal is removed. Therefore, if necessary, read the diagnosis before removing the battery terminal.

2. Do not smoke or work on open flame when working on the fuel system.
3. Keep gasoline off rubber or leather parts.

## INSPECTION PRECAUTIONS

### MAINTENANCE PRECAUTIONS

1. CHECK CORRECT ENGINE TUNE-UP  
(See page EM-6)

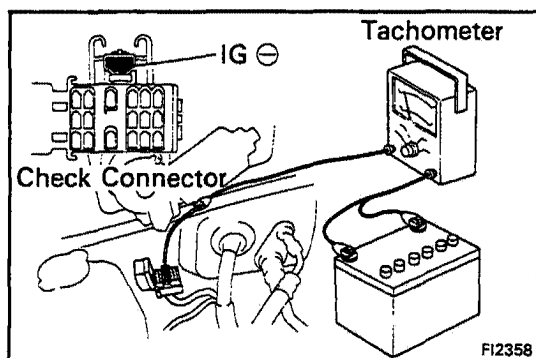

2. PRECAUTIONS WHEN CONNECTING GAUGE

- (a) Use the battery as the power source for the timing light, tachometer, etc.
- (b) Connect the test probe of a tachometer to the terminal IG $\ominus$  of the check connector.

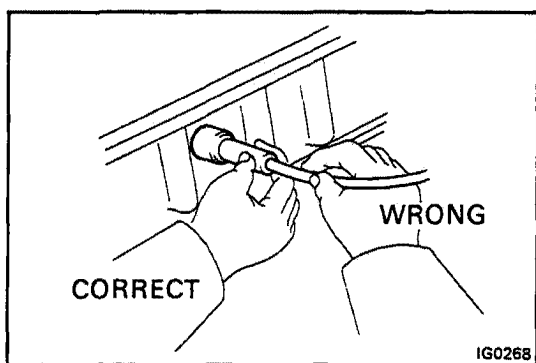

3. IN EVENT OF ENGINE MISFIRE FOLLOWING PRECAUTIONS SHOULD BE TAKEN

- (a) Check proper connection of battery terminals, etc.
- (b) Handle high-tension cords carefully.
- (c) After repair work, check that the ignition coil terminals and all other ignition system lines are reconnected securely.
- (d) When cleaning the engine compartment, be especially careful to protect the electrical system from water.

4. PRECAUTIONS WHEN HANDLING OXYGEN SENSORS

- (a) Do not allow oxygen sensor to drop or hit against an object.
- (b) Do not allow the sensor to come into contact with water.

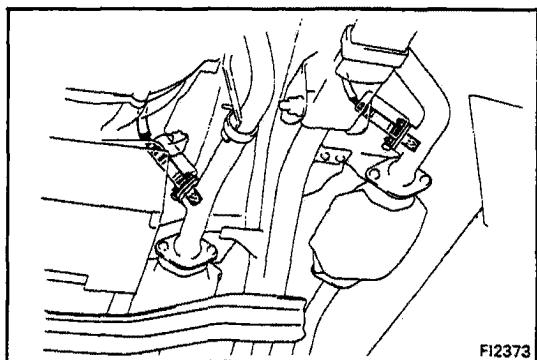

## IF VEHICLE IS EQUIPPED WITH MOBILE RADIO SYSTEM (HAM, CB, ETC.)

The ECU has been designed so that it will not be affected by outside interference.

However, if your vehicle is equipped with a CB radio transceiver, etc. (even one with about 10 W output), it may, at times, have an affect upon ECU operation, especially if the antenna and feeder are installed nearby.

Therefore, observe the following precautions:

1. Install the antenna as far as possible from the ECU. The ECU is located behind the glove box, so the antenna should be installed at the rear side of the vehicle.
2. Keep the antenna feeder as far away as possible from the ECU wires – at least 20 cm (7.87 in.) – and, especially, do not wind them together.
3. Check that the feeder and antenna are properly adjusted.
4. Do not equip your vehicle with a powerful mobile radio system.
5. Do not open the cover or the case of the ECU unless absolutely necessary.  
(If the IC terminals are touched, the IC may be destroyed by static electricity.)

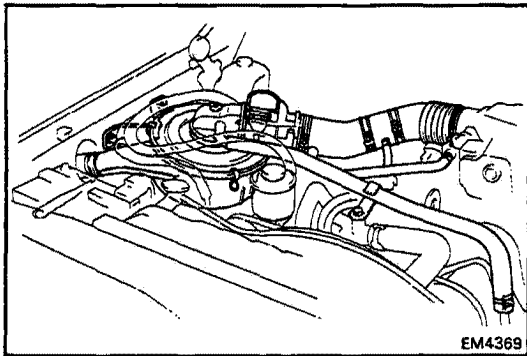
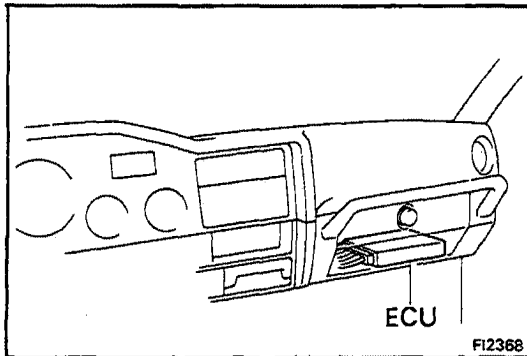

## AIR INDUCTION SYSTEM

1. Separation of the engine oil dipstick, oil filler cap, PCV hose, etc. may cause the engine to run out of tune.
2. Disconnection, looseness or cracks in the parts of the air induction system between the air flow meter and cylinder head will allow air suction and cause the engine to run out of tune.

## ELECTRONIC CONTROL SYSTEM

1. Before removing EFI wiring connectors, terminals, etc., first disconnect the power by either turning the ignition switch OFF or disconnecting the battery terminals.
2. When installing the battery, be especially careful not to incorrectly connect the positive (+) and negative (-) cables.
3. Do not permit parts to receive a severe impact during removal or installation. Handle all EFI parts carefully, especially the ECU.
4. Do not be careless during troubleshooting as there are numerous transistor circuits and even slight terminal contact can cause further troubles.
5. When inspecting during rainy weather, take care to prevent entry of water. Also, when washing the engine compartment, prevent water from getting on the EFI parts and wiring connectors.
6. Parts should be replaced as an assembly.

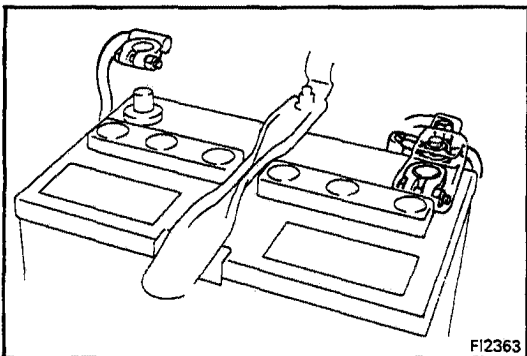

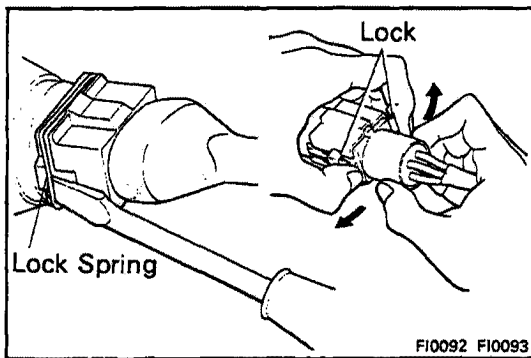

7. Care is required when pulling out and inserting wiring connectors.

(a) Release the lock and pull out the connector, pulling on the connectors.

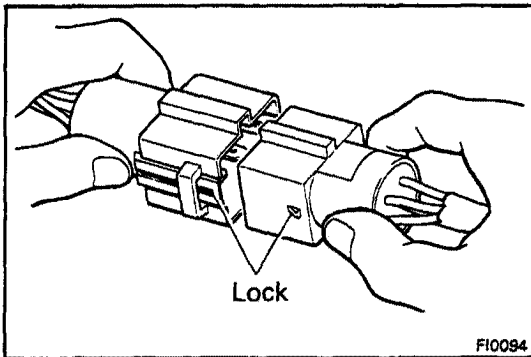

(b) Fully insert the connector and check that it is locked.

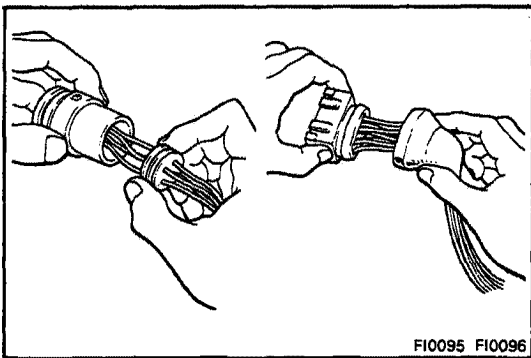

8. When inspecting a connector with a volt/ohmmeter.

(a) Carefully take out the water-proofing rubber if it is a water-proof type connector.

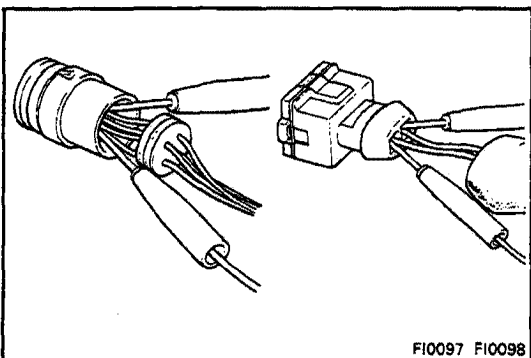

(b) Insert the test probe into the connector from wiring side when checking the continuity, amperage or voltage.

(c) Do not apply unnecessary force to the terminal.

(d) After checking, install the water-proofing rubber on the connector securely.

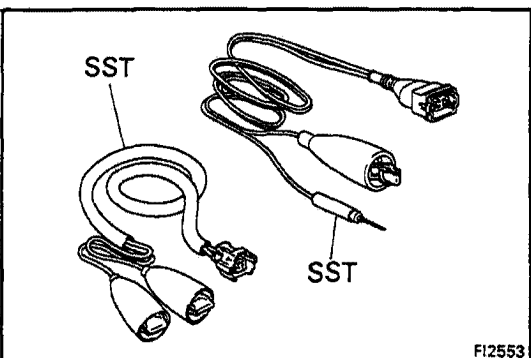

9. Use SST for inspection or test of the injector, cold start injector or its wiring connector.

SST 09842-30050 and 09842-30070

## FUEL SYSTEM

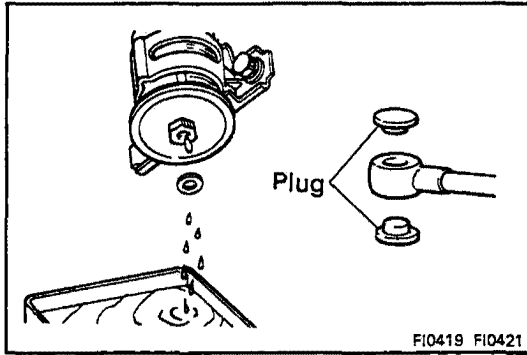

1. When disconnecting the high fuel pressure line, a large amount of gasoline will spill out, so observe the following procedure:
  - (a) Put a container under the connection.
  - (b) Slowly loosen the connection.
  - (c) Disconnect the connection.
  - (d) Plug the connection with a rubber plug.

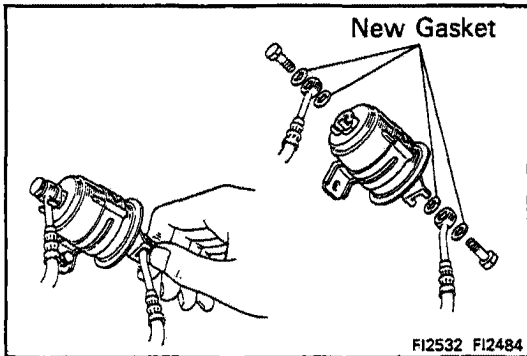

2. When connecting the flare nut or union bolt on the high pressure pipe union, observe the following procedure:
 

(Union Bolt Type)

  - (a) Always use a new gasket.
  - (b) Tighten the union bolt by hand.
  - (c) Tighten the union bolt to the specified torque.

**Torque: 300 kg-cm (22 ft-lb, 29 N·m)**

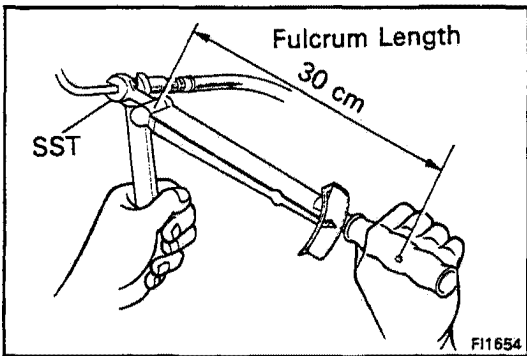

(Flare Nut Type)

- (a) Apply a light coat of engine oil the flare and tighten the flare nut by hand.
  - (b) Using SST, tighten the flare nut to specified torque.
- SST 09631-22020**

**Torque: 310 kg-cm (22 ft-lb, 30 N·m)**

**NOTE:** Use a torque wrench with a fulcrum length of 30 cm (11.81 in.).

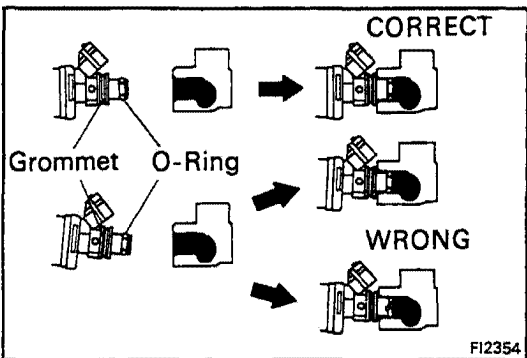

3. Observe the following precautions when removing and installing the injectors.
  - (a) Never reuse the O-ring.
  - (b) When placing a new O-ring on the injector, take care not to damage it in any way.
  - (c) Coat a new O-ring with spindle oil or gasoline before installing – never use engine, gear or brake oil.

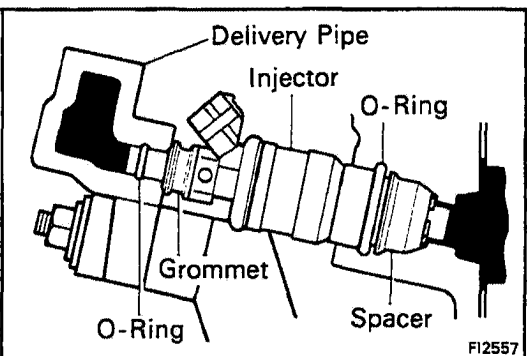

4. Install the injector to delivery pipe and cylinder head as shown in the figure.

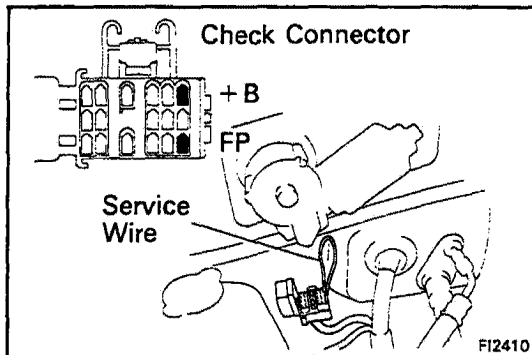

5. Check that there are no fuel leaks after performing any maintenance on the fuel system.
  - (a) With engine stopped, turn the ignition switch ON.
  - (b) Using a service wire, short terminals + B and FP of the check connector.

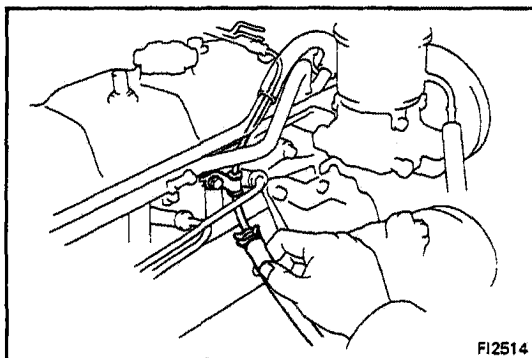

- (c) When the fuel return hose is pinched, the pressure within high pressure line will rise to approx. 4 kg/cm<sup>2</sup> (57 psi, 392 kPa). In this state, check to see that there are no leaks from any part of the fuel system.

**CAUTION:** Always pinch the hose. Avoid bending as it may cause the hose to crack.

# TROUBLESHOOTING

## TROUBLESHOOTING HINTS

1. Engine trouble are usually not caused by the EFI system. When troubleshooting, always first check the condition of the other systems.
  - (a) Electronic source
    - Battery
    - Fusible links
    - Fuses
  - (b) Body ground
  - (c) Fuel supply
    - Fuel leakage
    - Fuel filter
    - Fuel pump
  - (d) Ignition system
    - Spark plugs
    - High-tension cords
    - Distributor
    - Ignition coil
    - Igniter
  - (e) Air induction system
    - Vacuum leaks
  - (f) Emission control system
    - PCV system
    - EGR system
    - AI system
  - (g) Others
    - Ignition timing (ESA system)
    - Idle speed (ISC system)
    - etc.

2. The most frequent cause of problems is simply a bad contact in wiring connectors. Always check that connections are secure.

When inspecting the connector, pay particular attention to the following points:

- (a) Check to see that the terminals are not bent.
  - (b) Check to see that the connector is pushed in completely and locked.
  - (c) Check to see that there is no signal change when the connector is slightly tapped or wiggled.
3. Sufficiently troubleshooting for other causes before replacing the ECU, as the ECU is of high quality and expensive.

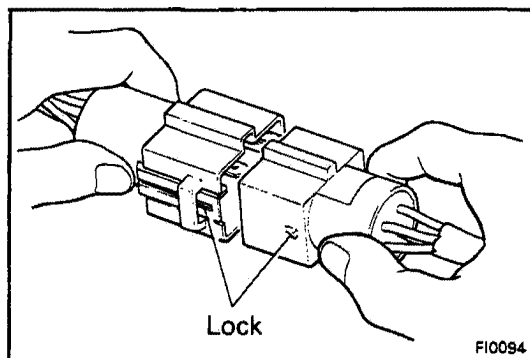

FI0094

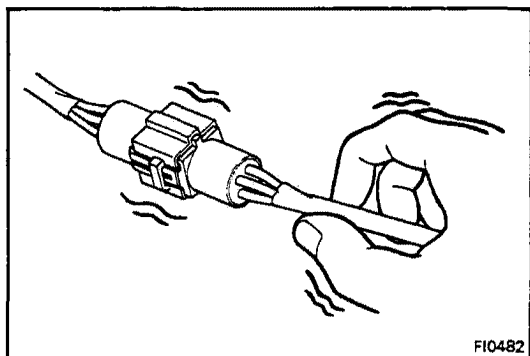

FI0482

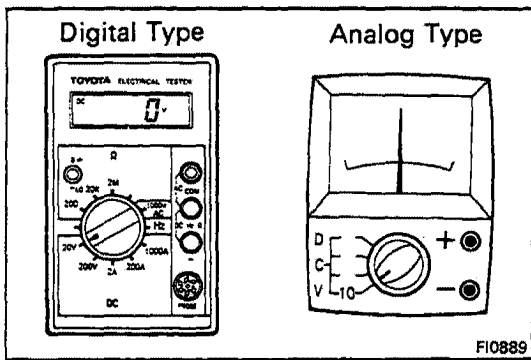

- Use a volt / ohmmeter with high impedance (10 kΩ/V minimum) for troubleshooting of the electrical circuit. (See page FI-27)

### TROUBLESHOOTING PROCEDURES

#### SYMPTOM – DIFFICULT TO START OR NO START (ENGINE WILL NOT CRANK OR CRANKS SLOWLY)

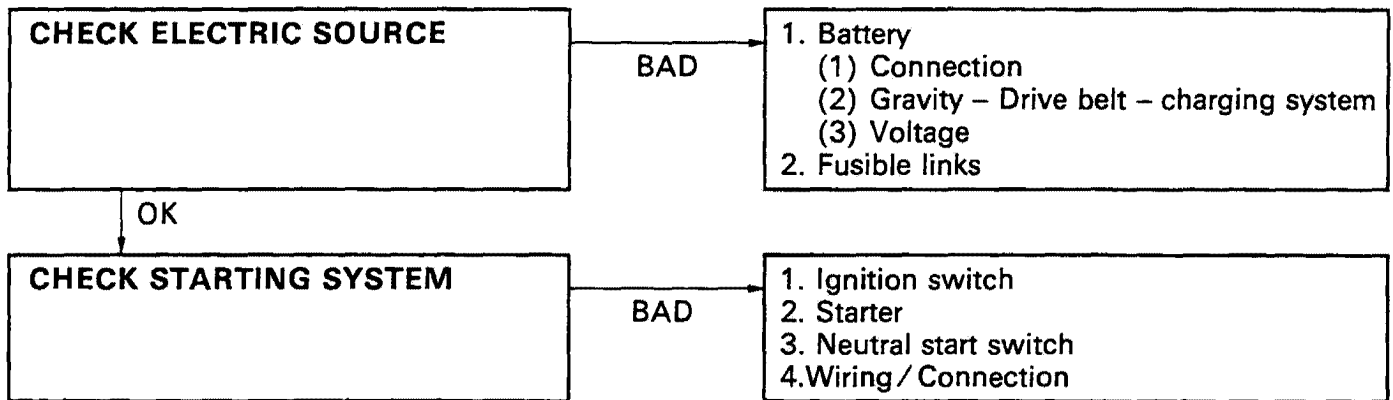

#### SYMPTOM – DIFFICULT TO START OR NO START (CRANKS OK)

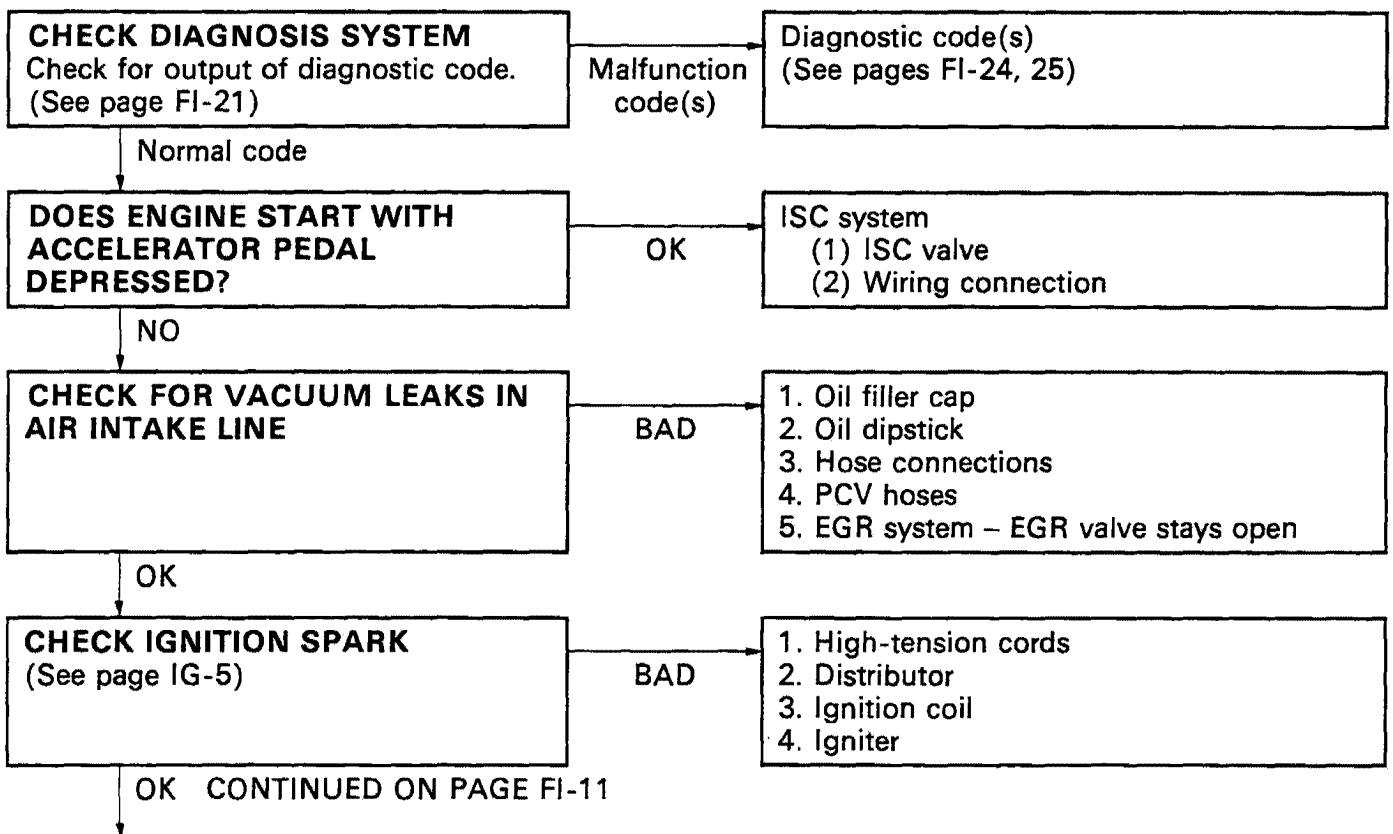

OK CONTINUED FROM PAGE FI-10

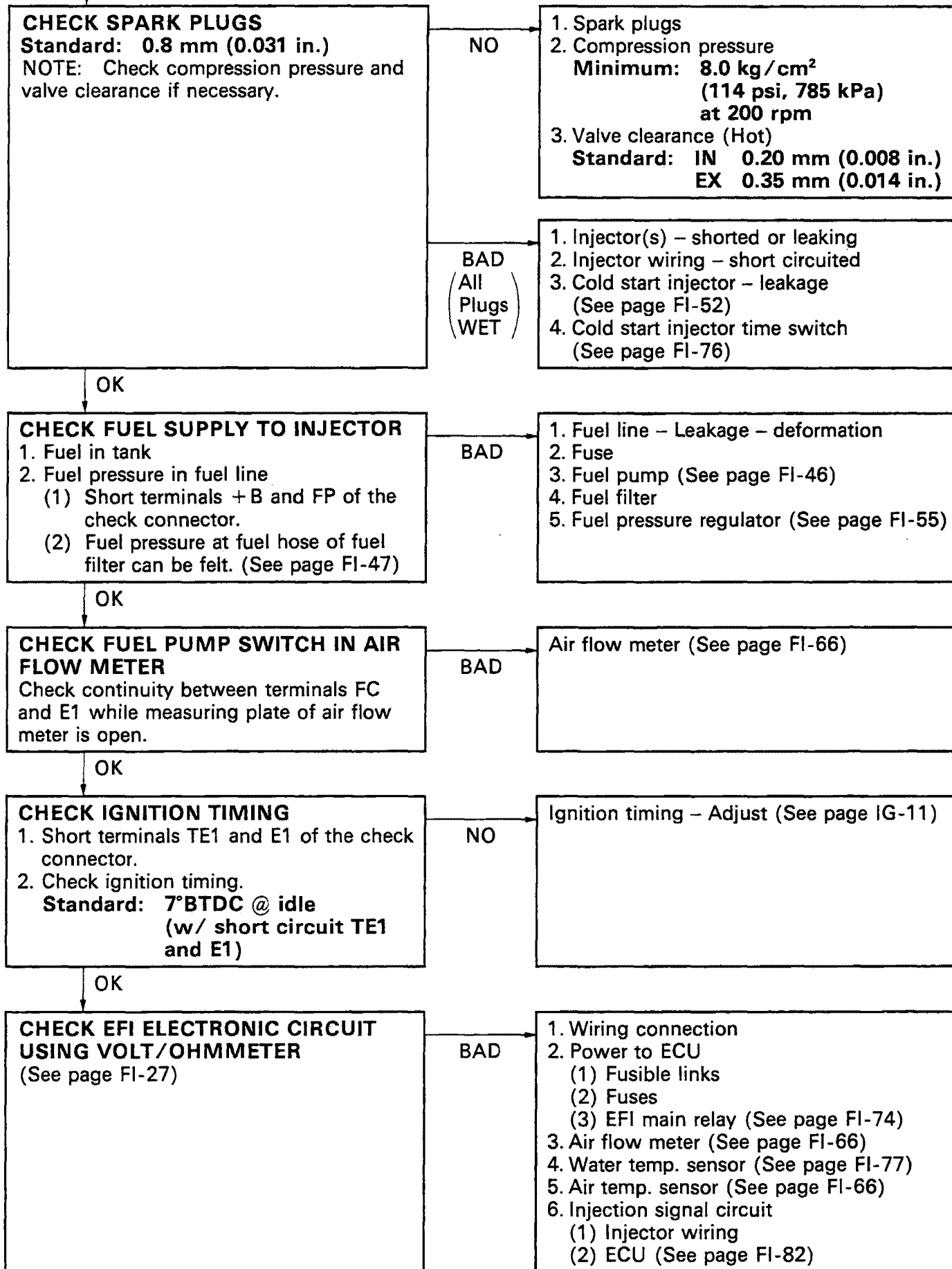

**SYMPTOM – ENGINE OFTEN STALLS**

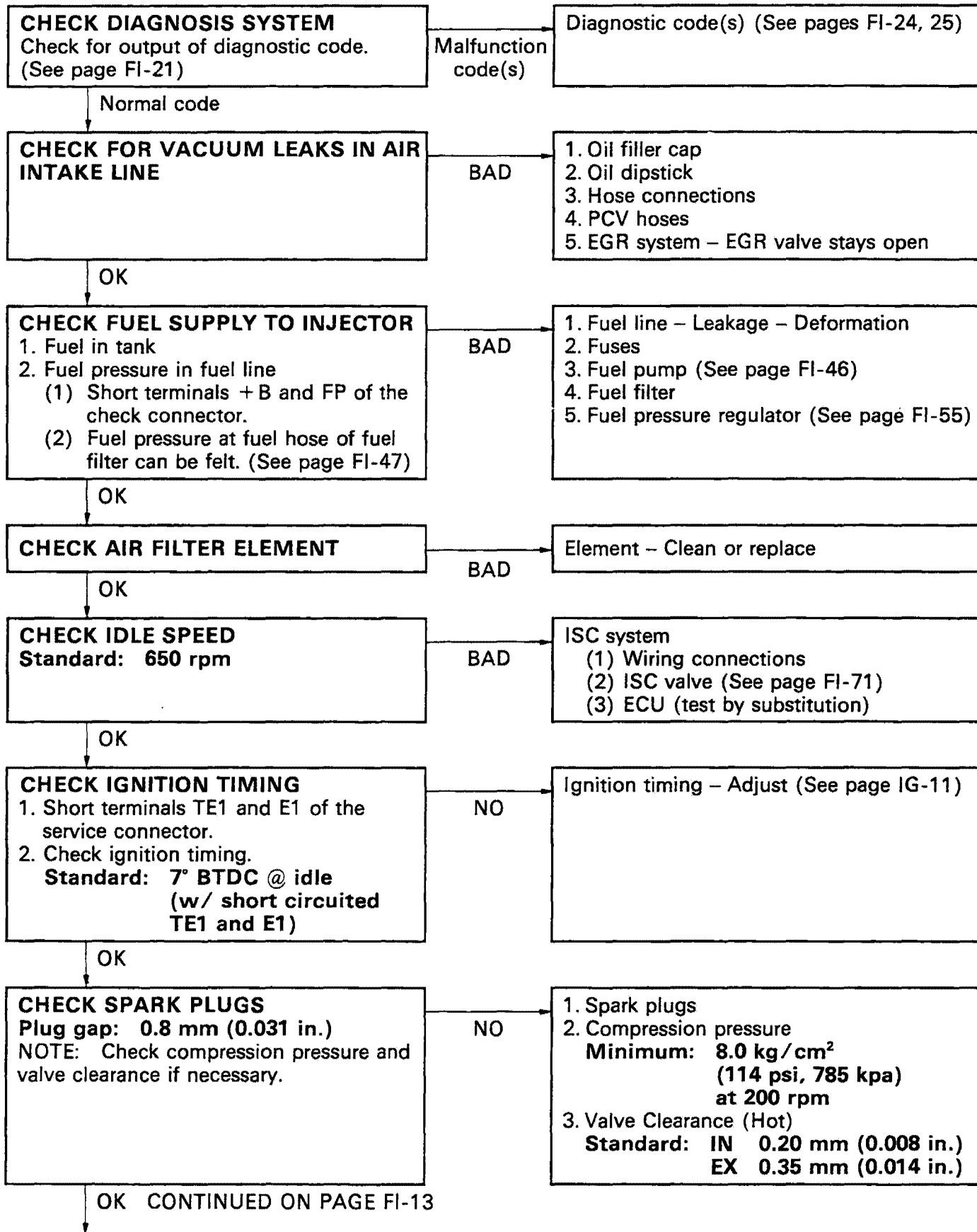

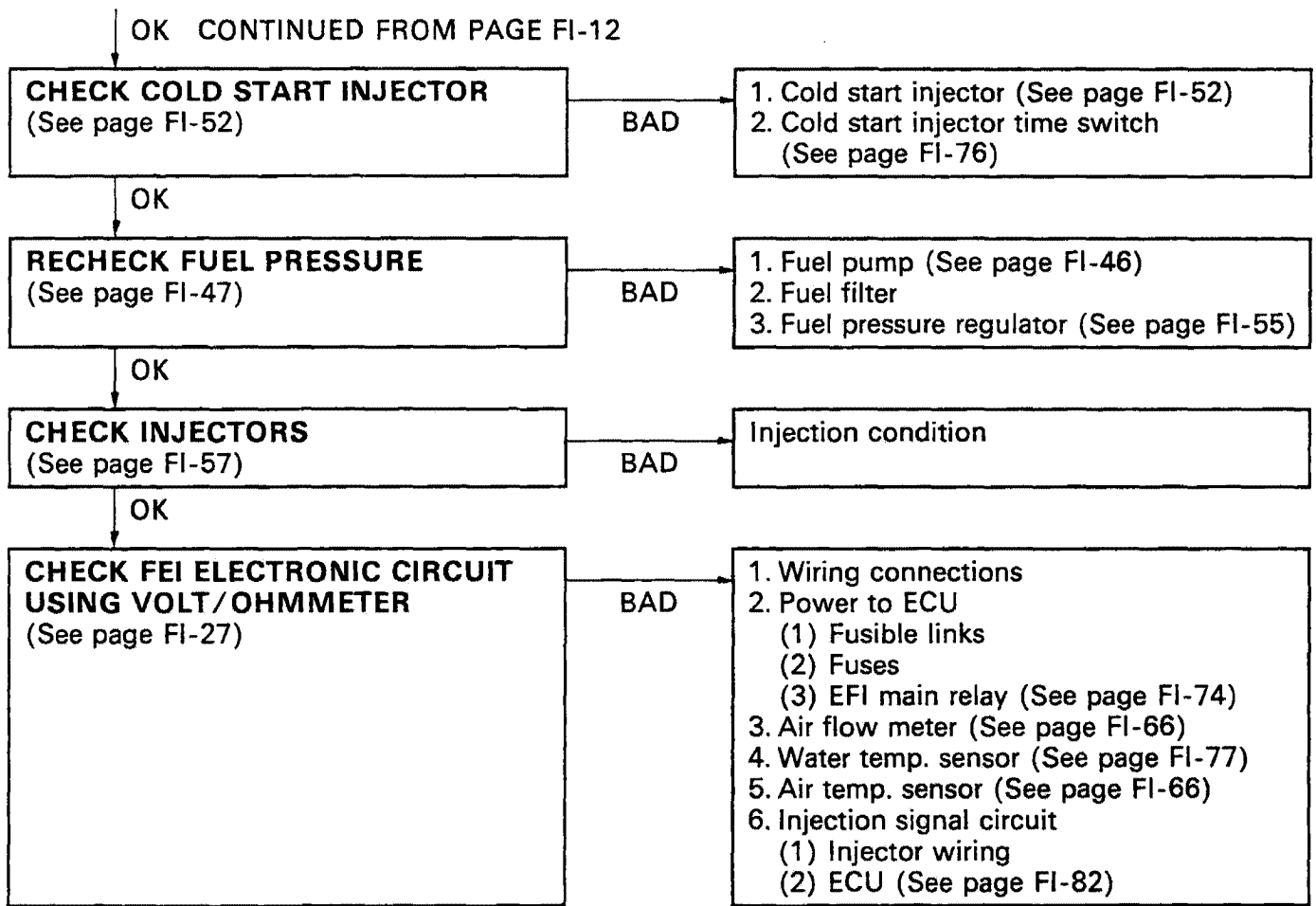

**SYMPTOM – ENGINE SOMETIMES STALLS**

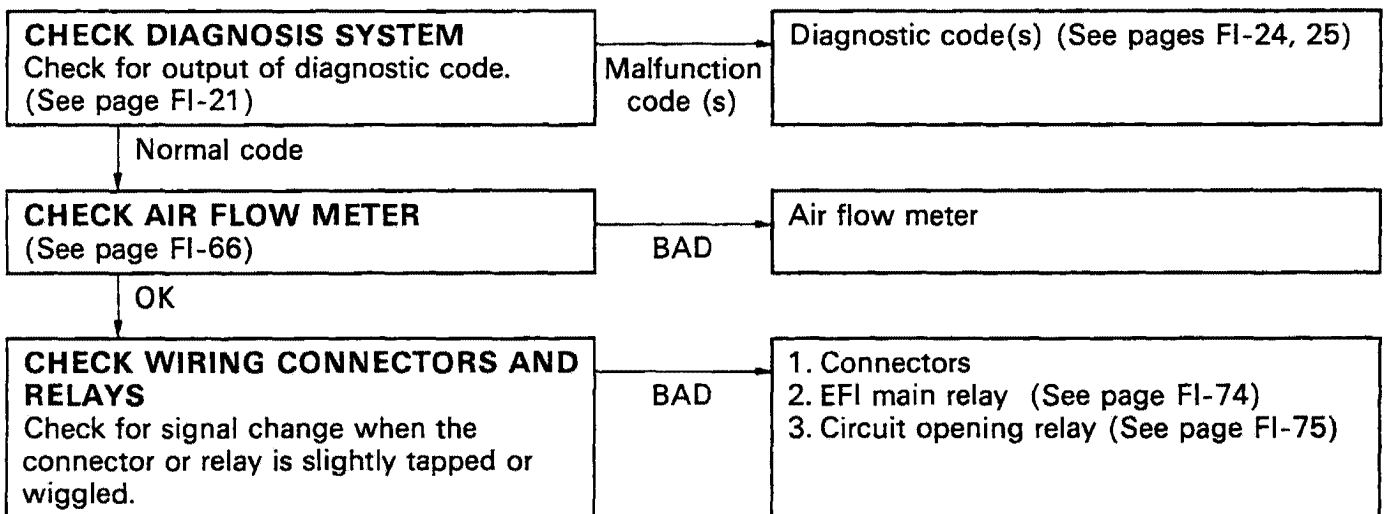

**SYMPTOM – ROUGH IDLING AND/OR MISSING**

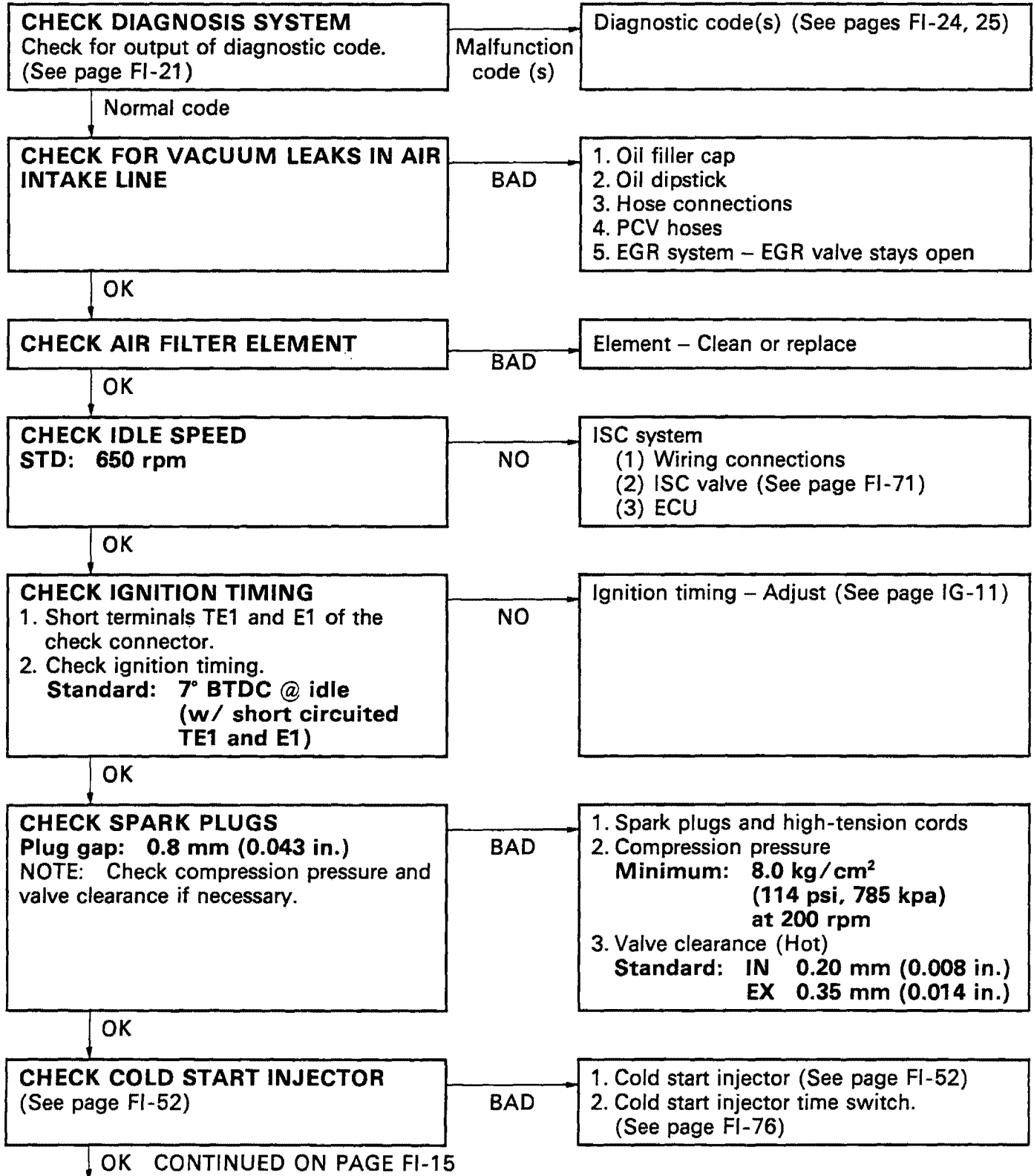

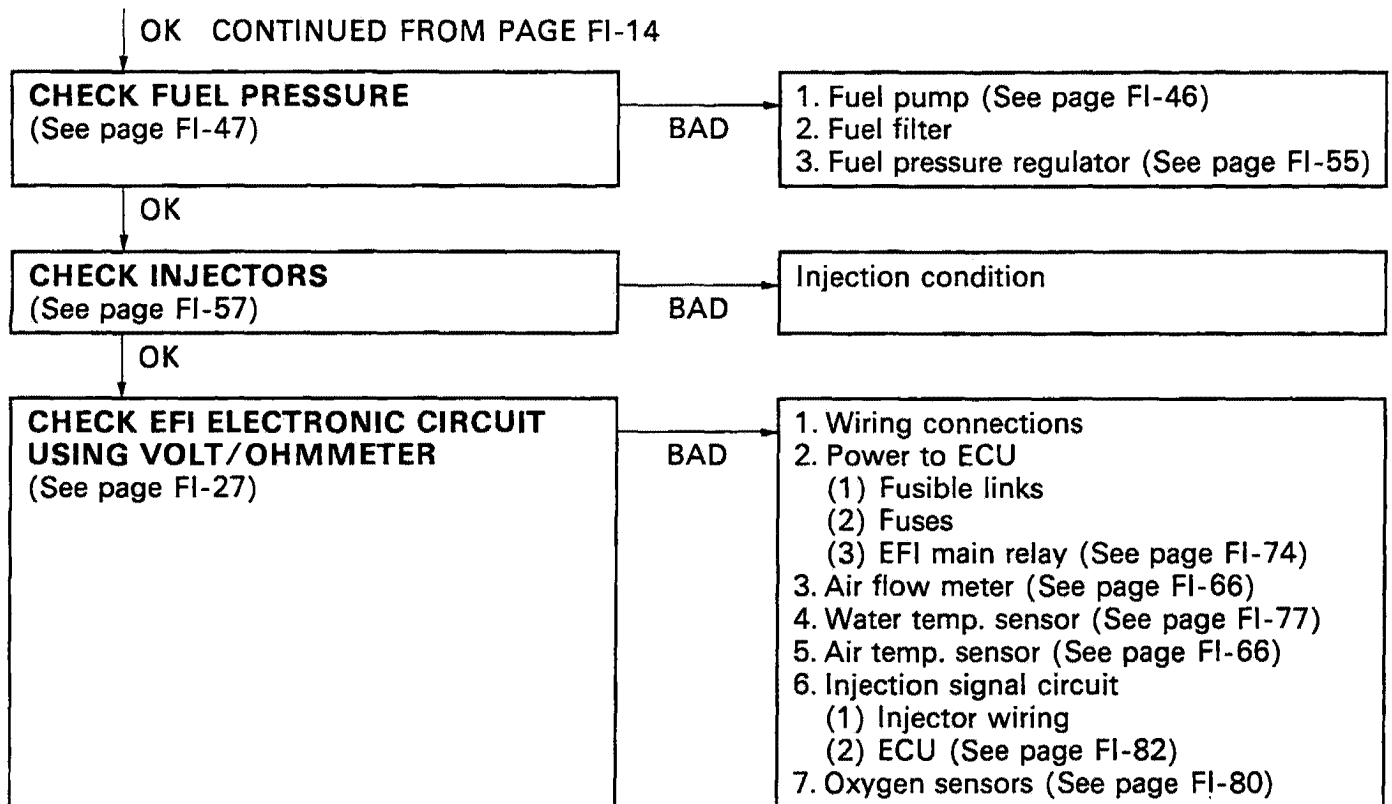

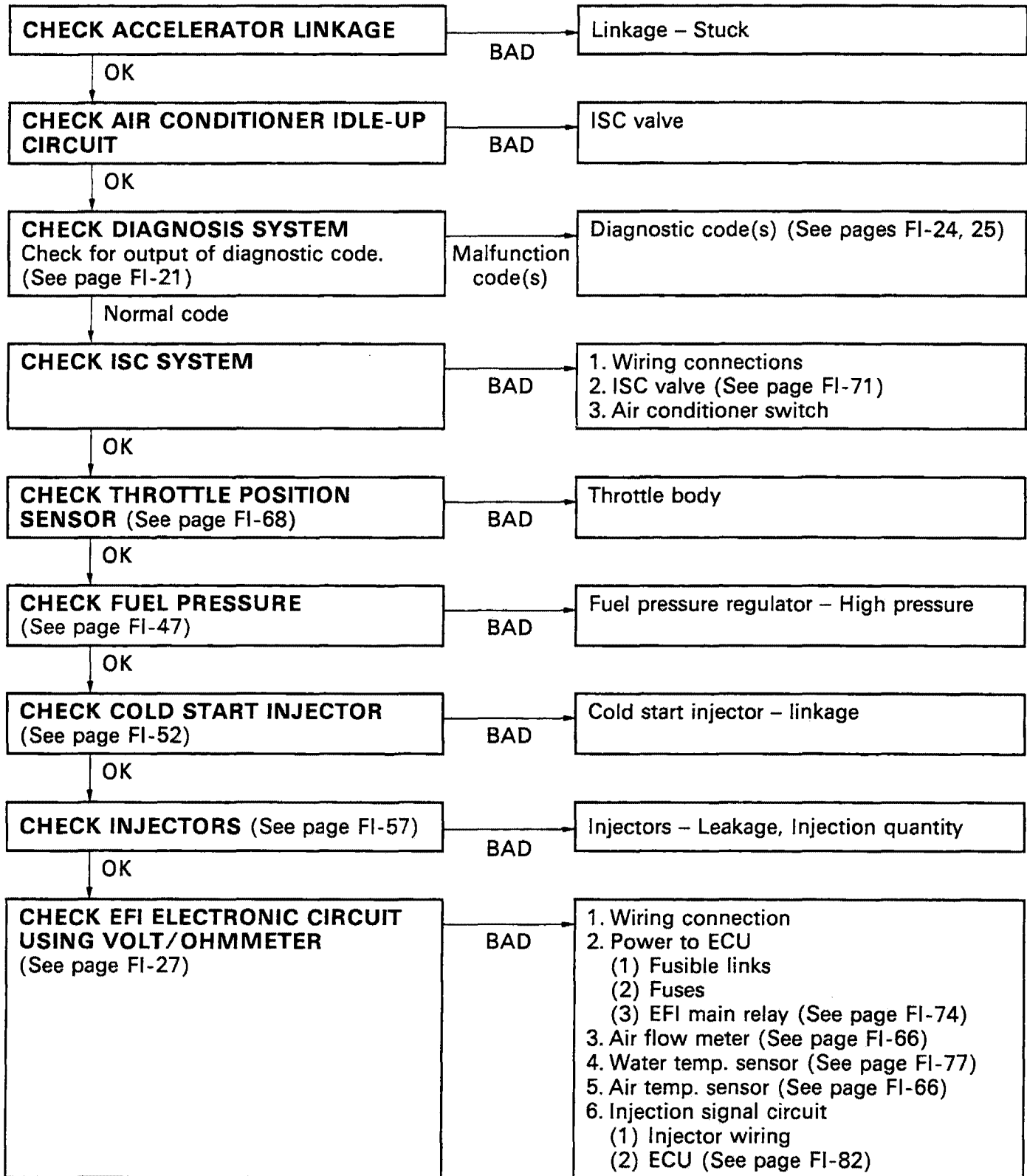
**SYMPTOM – HIGH ENGINE IDLE SPEED (NO DROP)**

## SYMPTOM – ENGINE BACKFIRES-Lean Fuel Mixture

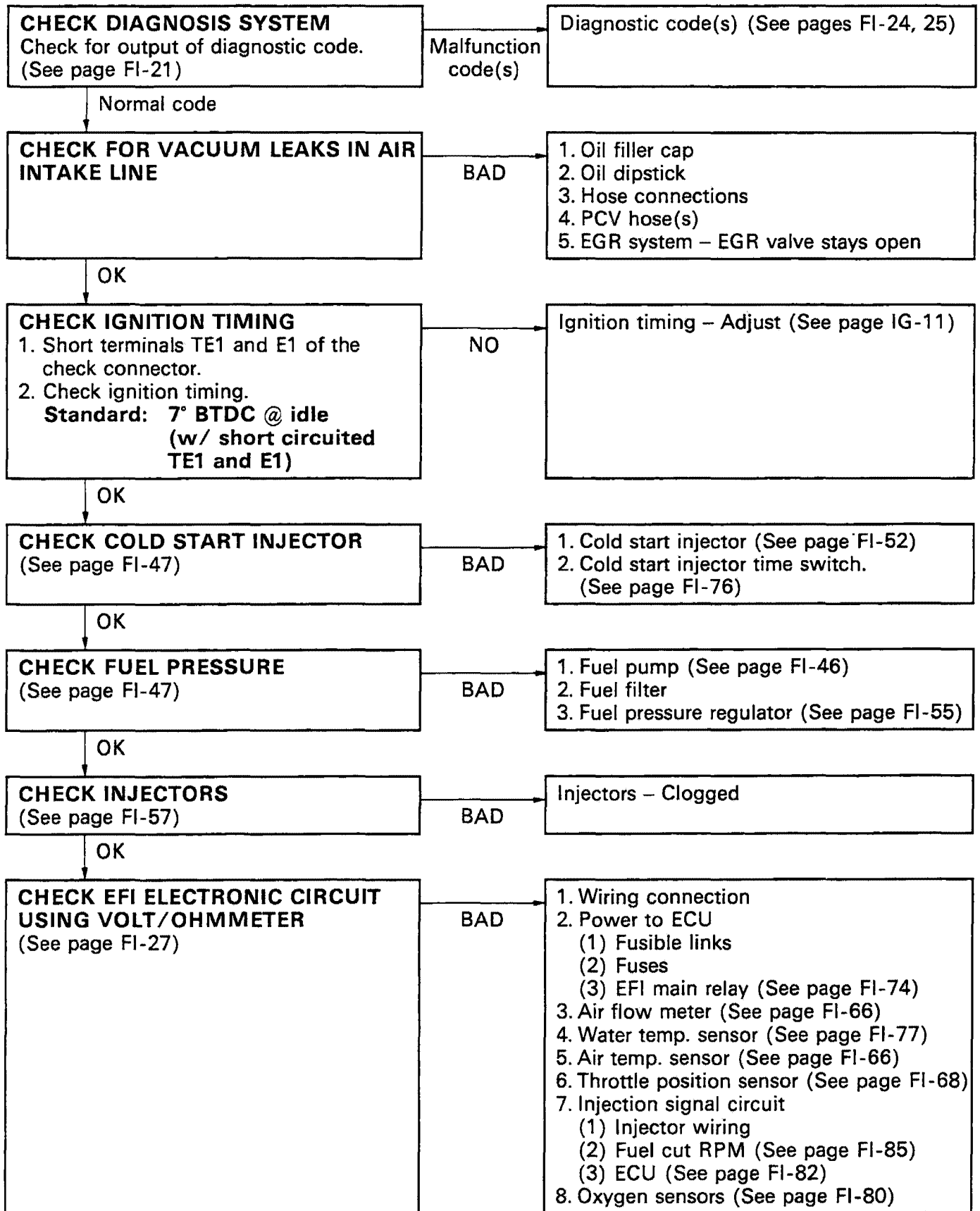

## SYMPTOM – MUFFLER EXPLOSION (AFTER FIRE)- Rich Fuel Mixture-Misfire

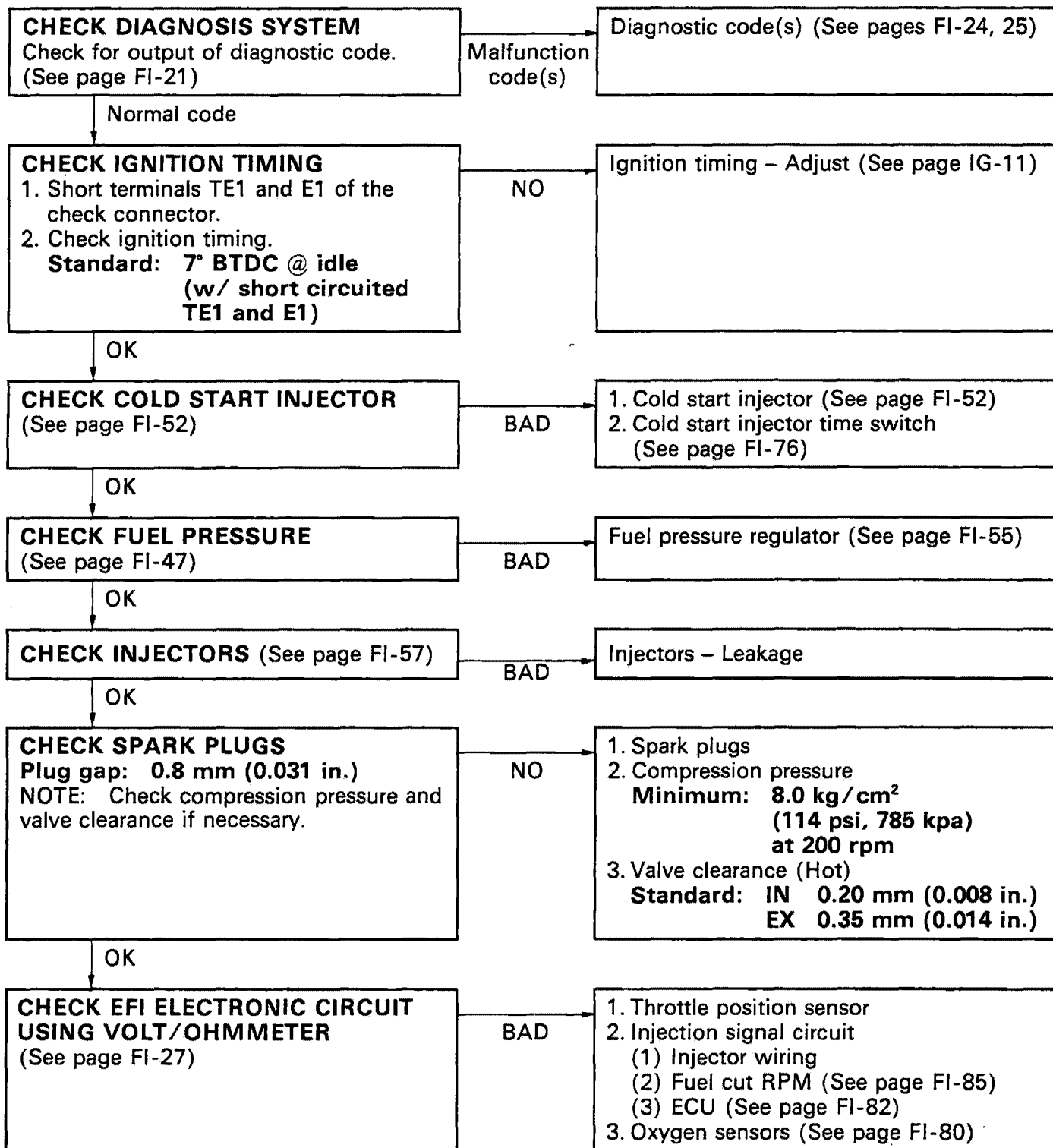

**SYMPTOM – ENGINE HESITATES AND/OR POOR ACCELERATION**

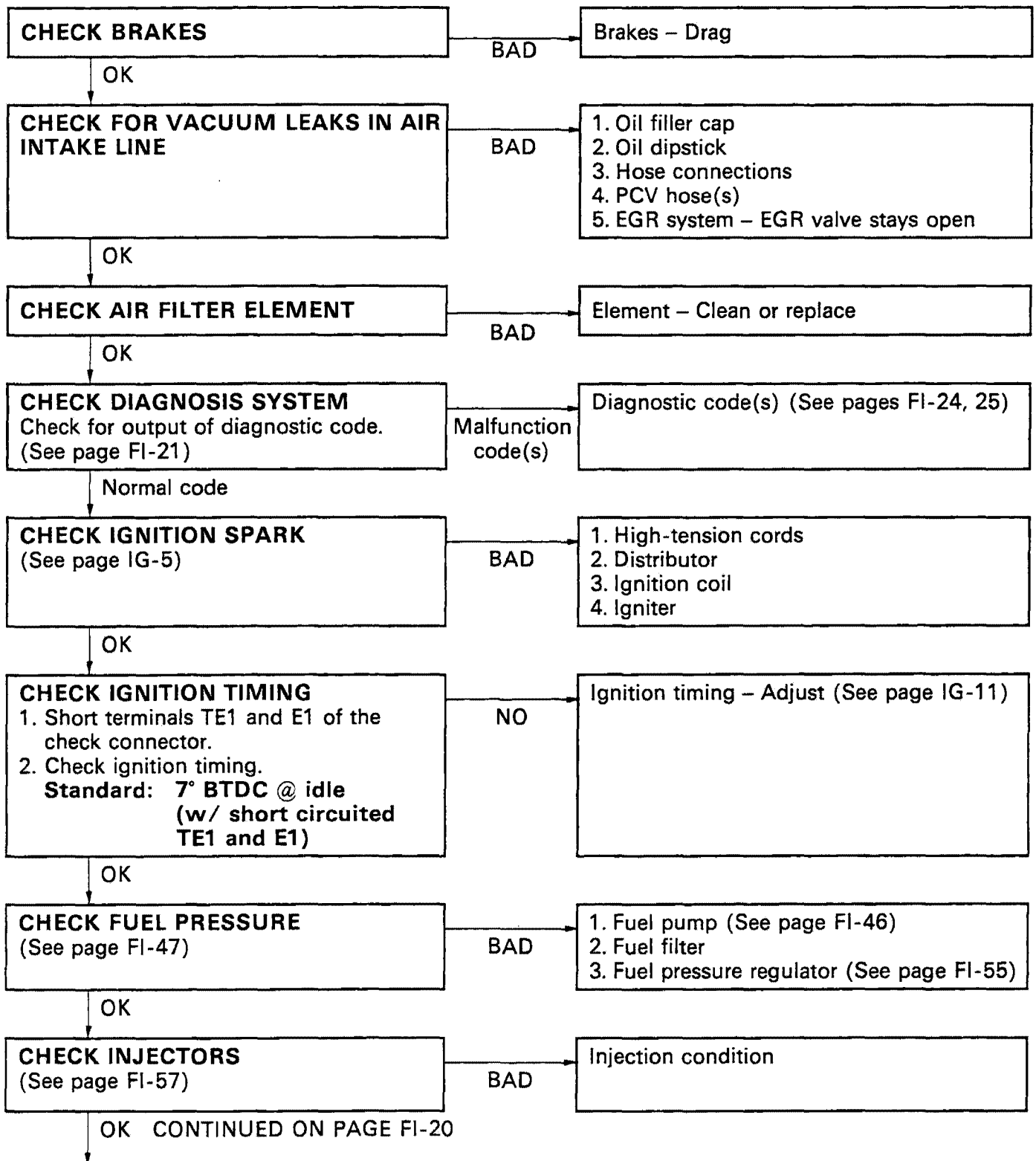

CONTINUED FROM PAGE FI-19

**CHECK SPARK PLUGS****Plug gap: 0.8 mm (0.031 in.)**

NOTE: Check compression pressure and valve clearance if necessary.

NO

1. Spark plugs
2. Compression pressure  
**Minimum: 8.0 kg/cm<sup>2</sup>**  
**(114 psi, 785 kpa)**  
**at 200 rpm**
3. Valve clearance (Hot)  
**Standard: IN 0.20 mm (0.008 in.)**  
**EX 0.35 mm (0.014 in.)**

OK

**CHECK EFI ELECTRONIC CIRCUIT  
USING VOLT/OHMMETER**  
(See page FI-27)

BAD

1. Wiring connections
2. Power to ECU
  - (1) Fusible links
  - (2) Fuses
  - (3) EFI main relay (See page FI-74)
3. Air flow meter (See page FI-66)
4. Water temp. sensor (See page FI-77)
5. Air temp. sensor (See page FI-66)
6. Throttle position sensor (See page FI-68)
7. Injection signal circuit
  - (1) Injector wiring
  - (2) ECU (See page FI-82)

# DIAGNOSIS SYSTEM

## DESCRIPTION

The ECU contains a built-in self-diagnosis system by which troubles with the engine signal network are detected and a "CHECK" engine warning light on the instrument panel flashes.

By analyzing various signals as shown in the later tables (See pages FI-24, 25) the ECU detects system malfunctions which are related to the various operating parameter sensors or actuator. The ECU stores the failure code associated with the detected failure until the diagnosis system is cleared by removing the EFI fuse with the ignition switch OFF.

The "CHECK" engine warning light on the instrument panel informs the driver that a malfunction has been detected.

The light goes out automatically when the malfunction has been cleared.

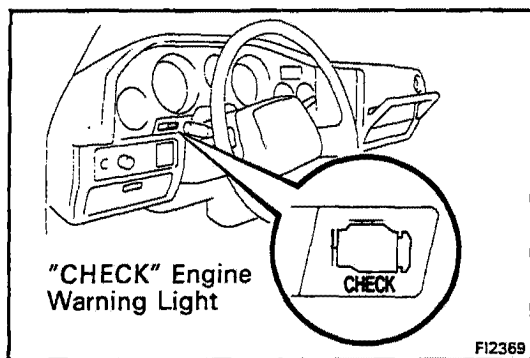

## "CHECK" ENGINE WARNING LIGHT CHECK

1. The "CHECK" engine warning light will come on when the ignition switch is placed at ON and the engine is not running.
2. When the engine is started, the "CHECK" engine warning light should go out. If the light remains on, the diagnosis system has detected a malfunction or abnormality in the system.

## OUTPUT OF DIAGNOSTIC CODES

To obtain an output of diagnostic codes, proceed as follow:

1. Initial conditions
  - (a) Battery voltage 11 volts or more
  - (b) Throttle valve fully closed (throttle position sensor IDL points closed)
  - (c) Transmission in neutral position
  - (d) Accessories switched OFF
  - (e) Engine at reach normal operating temperature
2. Turn the ignition switch to ON. Do not start the engine.
3. Using a service wire, short terminals TE1 and E1 of the check connector.

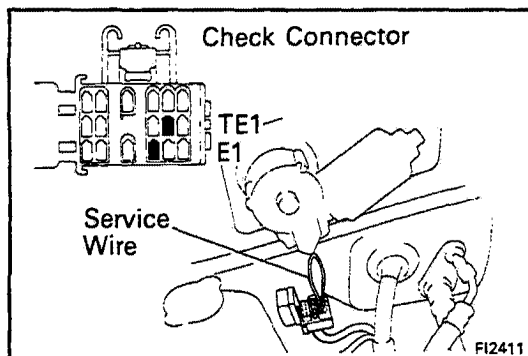

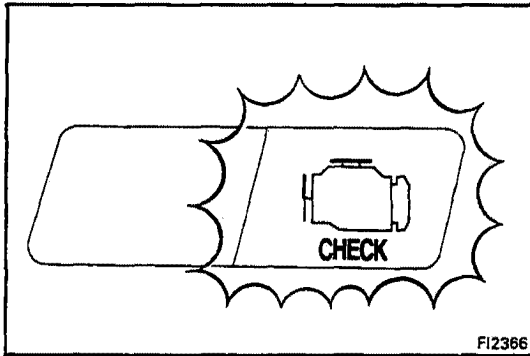

4. Read the diagnostic code as indicated by the number of flashes of the "CHECK" engine warning light.

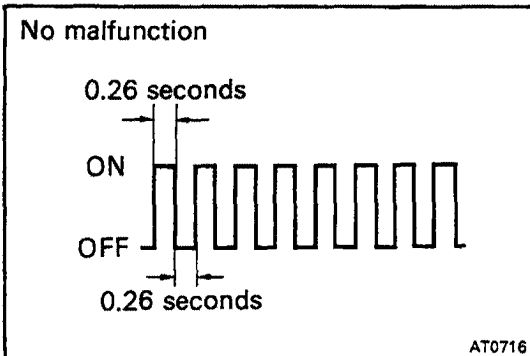

Diagnostic Codes (See pages FI-24, 25)

(a) Normal System Operation (no malfunction)

- The light will alternately blink on and OFF for 0.26 second intervals.

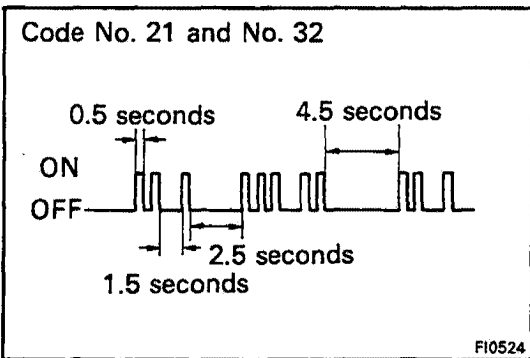

(b) Malfunction Code Indication

- In the event of a malfunction, the light will blink every 0.5 seconds. The first number of blinks will equal the first digit of a 2-digit diagnostic code and, after a 1.5 second pause, the 2nd number of blinks will equal the 2nd. If there are two or more codes, there will be a 2.5 second pause between each.
- After all the codes have been output, there will be a 4.5 second pause and they will all be repeated as long as the terminals TE1 and E1 of the check connector are shorted.

NOTE: In the event of a number of trouble codes, indication will begin from the smaller value and continue in order to the larger.

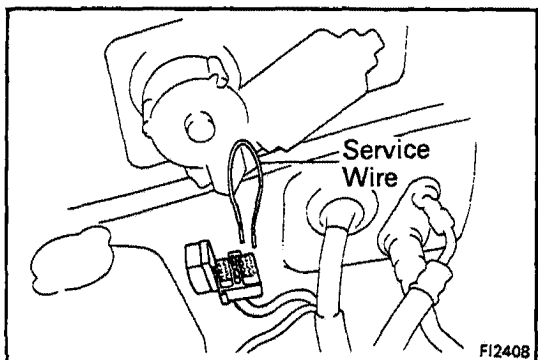

5. After the diagnosis check, remove the service wire.

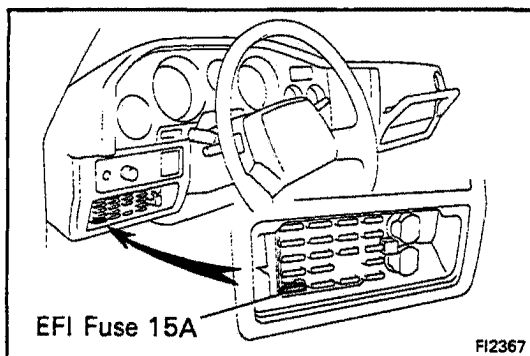

## CANCELLING DIAGNOSTIC CODE

1. After repair of trouble area, the diagnostic code retained in memory by the ECU must be cancelled out by removing the EFI fuse (15A) for 30 seconds or more, depending on ambient temperature (the lower the temperature, the longer the fuse must be left out) with the ignition switch OFF.

### NOTE:











- Cancellation can also be done by removing the battery negative (-) terminal, but in this case, other memory systems (clock, etc.) will also be cancelled out.
  - If the diagnostic code is not cancelled out, it will be retained by the ECU and appear along with a new code in the event of future trouble.
  - If it is necessary to work on engine components requiring removal of the battery terminal, a check must first be made to see if a diagnostic code has been recorded.
2. After cancellation, road test the vehicle to check that a "normal" code is now read on the "CHECK" engine warning light.

If the same diagnostic code appears, it indicates that the trouble area has not been repaired thoroughly.









## DIAGNOSIS INDICATION

1. Including "normal", the ECU is programmed with the following 18 (ex. California vehicles) or 19 (California vehicles) diagnostic codes.
2. When 2 or more codes are indicated, the lowest number (code) will appear first.  
However, no other code will appear along with code No.11.
3. All detected diagnostic codes, except code No.51, will be retained in memory by the ECU from the time of detection until cancelled out.
4. Once the malfunction is cleared, the "CHECK" engine warning light on the instrument panel will go out but the diagnostic code(s) remain stored in ECU memory (except for code No.51).

### DIAGNOSTIC CODES

Code No.	Number of Check engine blinks	System	Diagnosis	Trouble area	See page
—	 FI1604	Normal	This appears when none of the other codes are identified.	—	—
11	 FI1605	ECU (+ B)	Momentary interruption in power supply to ECU.	<ul style="list-style-type: none"> <li>• Ignition switch circuit</li> <li>• Ignition switch</li> <li>• Main relay circuit</li> <li>• Main relay</li> <li>• ECU</li> </ul>	FI-30
12	 FI1606	PRM Signal	No "NE" or "G" signal to ECU within 2 seconds after engine has been cranked.	<ul style="list-style-type: none"> <li>• Distributor circuit</li> <li>• Distributor</li> <li>• Starter signal circuit</li> <li>• ECU</li> </ul>	IG-4
13	 FI1607	RPM Signal	No "NE" signal to ECU when engine speed is above 1,000 rpm.	<ul style="list-style-type: none"> <li>• Distributor circuit</li> <li>• Distributor</li> <li>• ECU</li> </ul>	—
14	 FI1608	Ignition Signal	No "IGF" signal to ECU 6 – 8 times in succession.	<ul style="list-style-type: none"> <li>• Igniter and ignition coil circuit</li> <li>• Igniter and ignition coil</li> <li>• ECU</li> </ul>	FI-41
21	 FI1609	Oxygen Sensor Signal	Detects deterioration of oxygen sensor.	<ul style="list-style-type: none"> <li>• Oxygen sensor circuit</li> <li>• Oxygen sensor</li> <li>• ECU</li> </ul>	FI-44
		Oxygen Sensor Heater Signal	Open or short circuit in oxygen sensor heater.	<ul style="list-style-type: none"> <li>• Oxygen sensor heater circuit</li> <li>• Oxygen sensor heater</li> <li>• ECU</li> </ul>	
22	 FI1610	Water Temp. Sensor Signal	Open or short circuit in water temp. sensor signal.	<ul style="list-style-type: none"> <li>• Water temp. sensor circuit</li> <li>• Water temp. sensor</li> <li>• ECU</li> </ul>	FI-37
24	 FI1611	Intake Air Temp. Sensor Signal	Open or short circuit in intake air temp. sensor signal.	<ul style="list-style-type: none"> <li>• Intake air temp. sensor circuit</li> <li>• Intake air temp. sensor</li> <li>• ECU</li> </ul>	FI-36
25	 FI2562	Air-fuel Ratio Lean Malfunction	<p>(1) When air-fuel ratio feedback compensation value or adaptive control value continues at the upper (lean) or lower (rich) limit renewed for a certain.</p> <p>(2) When air-fuel ratio feedback compensation value or adaptive control value feedback frequency is abnormally high during feedback condition.</p>	<ul style="list-style-type: none"> <li>• Injector circuit</li> <li>• Injector</li> <li>• Fuel line pressure</li> <li>• Air flow meter</li> <li>• Air intake system</li> <li>• Oxygen sensor circuits</li> <li>• Oxygen sensors</li> <li>• Ignition system</li> <li>• ECU</li> </ul>	—
26	 FI2563	Air-fuel Ratio Rich Malfunction	NOTE: For condition (2), since neither a lean (Code No. 25) nor a rich (Code No. 26) diagnosis displayed consecutively.	<ul style="list-style-type: none"> <li>• Injector circuit</li> <li>• Injector</li> <li>• Fuel line pressure</li> <li>• Air flow meter</li> <li>• Cold start injector</li> <li>• ECU</li> </ul>	—
28	 FI2698	No. 2 Oxygen Sensor Signal	Same as code No. 21	Same as code No. 21	FI-44
		No. 2 Oxygen Sensor Heater			

## DIAGNOSTIC CODES (Cont'd)

Code No.	Number of Check engine blinks	System	Diagnosis	Trouble area	See page
31	 FI1612	Air flow Meter Signal	Open circuit in VC signal or short circuit between VS and E2 when idle contacts are closed.	<ul style="list-style-type: none"> <li>● Air flow meter circuit</li> <li>● Air flow meter</li> <li>● ECU</li> </ul>	FI-35
32	 FI1613	Air Flow Meter Signal	Open circuit in E2 or short circuit between VC and VS.	<ul style="list-style-type: none"> <li>● Air flow meter circuit</li> <li>● Air flow meter</li> <li>● ECU</li> </ul>	FI-35
35	 FI2699	HAC Sensor Signal	Open circuit in altitude compensation sensor signal.	<ul style="list-style-type: none"> <li>● ECU</li> </ul>	—
41	 FI1614	Throttle Position Sensor Signal	Open or short circuit in throttle position sensor signal.	<ul style="list-style-type: none"> <li>● Throttle position sensor circuit</li> <li>● Throttle position sensor</li> <li>● ECU</li> </ul>	FI-33
42	 FI1615	Vehicle Speed Sensor Signal	No "SPD" signal for 8 seconds when engine speed in between 2,000 rpm and 5,000 rpm and coolant temp. is below 80°C (176°F) except when racing the engine.	<ul style="list-style-type: none"> <li>● Vehicle speed sensor circuit</li> <li>● Vehicle speed sensor</li> <li>● ECU</li> </ul>	—
43	 FI1616	Starter Signal	No "STA" signal to ECU until engine speed reaches 800 rpm with vehicle not moving	<ul style="list-style-type: none"> <li>● Ignition switch circuit</li> <li>● Ignition switch</li> <li>● ECU</li> </ul>	FI-39
71	 FI2622	RGR System Malfunction	EGR gas temp. below predetermined level during EGR operation.	<ul style="list-style-type: none"> <li>● EGR valve</li> <li>● EGR hose</li> <li>● EGR gas temp. sensor circuit</li> <li>● EGR gas temp. sensor</li> <li>● VSV for EGR</li> <li>● VSV for EGR circuit</li> <li>● ECU</li> </ul>	FI-45
51	 FI1617	Switch Signal	No "IDL" signal, "NSW" signal or "A/C" signal to ECU, with the check terminals E1 and TE1 shorted.	<ul style="list-style-type: none"> <li>● A/C switch circuit</li> <li>● A/C switch</li> <li>● A/C amplifire</li> <li>● Throttle position sensor circuit</li> <li>● Throttle position sensor</li> <li>● Neutral start switch</li> <li>● Neutral start switch</li> <li>● Acceleration pedal and cable</li> <li>● ECU</li> </ul>	—

\* California vehicles only

### INSPECTION OF DIAGNOSIS CIRCUIT

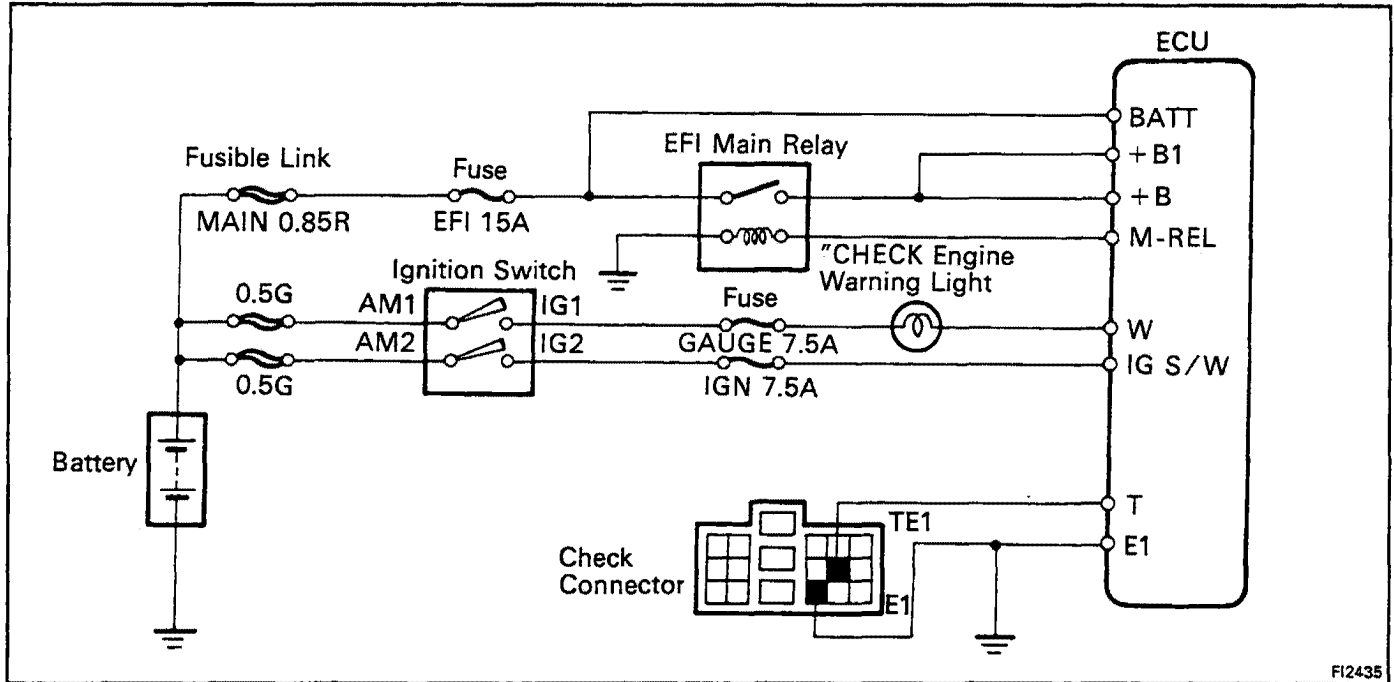

FI2435

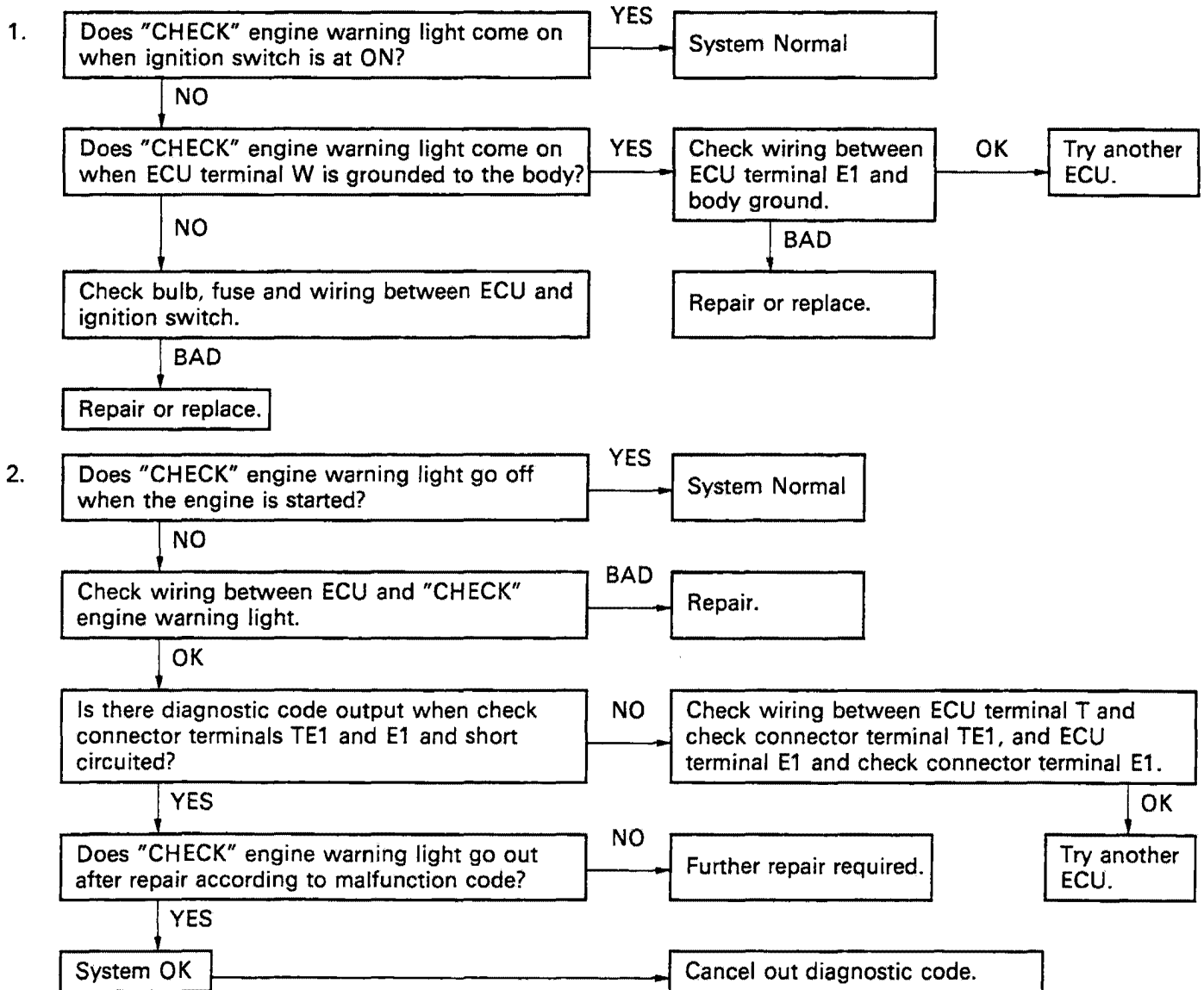

## TROUBLESHOOTING WITH VOLT/OHMMETER

**NOTE:** The following troubleshooting procedures are designed for inspection of each separate system, and therefore the actual procedure may vary somewhat. However, troubleshooting should be performed referring to the inspection methods described in this manual.

Before beginning inspection, it is best to first make a simple check of the fuses, fusible links and the condition of the connectors.

The following troubleshooting procedures are based on the supposition that the trouble lies in either a short or open circuit in a component outside the computer or a short circuit within the computer.

If engine trouble occurs even though proper operating voltage is detected in the computer connector, then it can be assumed that the ECU is faulty and should be replaced.

### LOCATION OF FUSES AND FUSIBLE LINKS

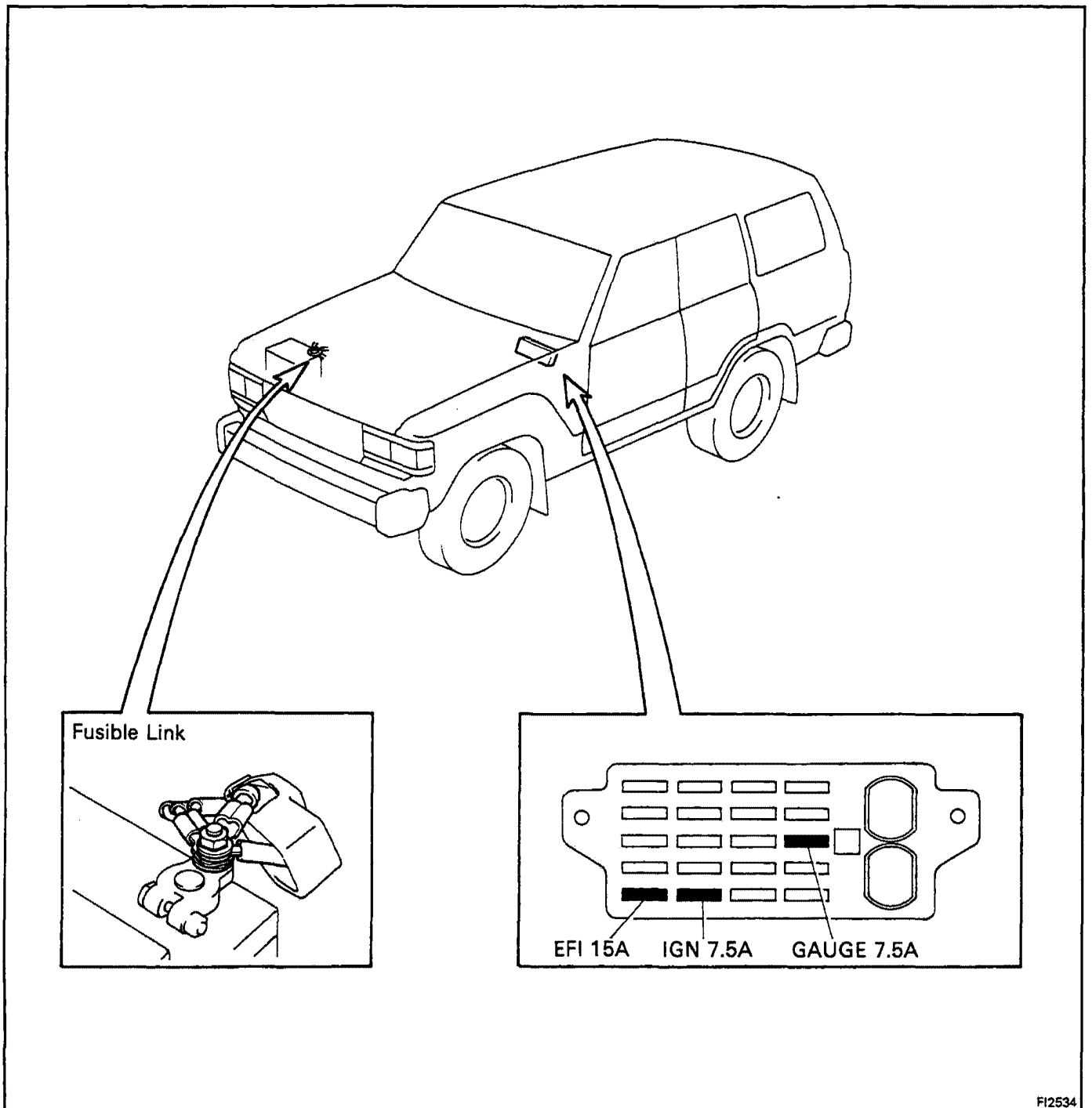

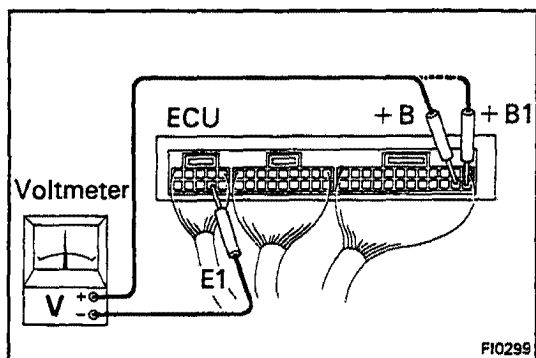

### EFI SYSTEM CHECK PROCEDURE

**NOTE:**

- Perform all voltage measurements with the connectors connected.
- Verify that the battery voltage is 11 V or more when the ignition switch is at "ON".

Using a voltmeter with high impedance (10 kΩ/V minimum), measure the voltage at each terminal of the wiring connectors.

### Terminals of ECU

Symbol	Terminal Name	Symbol	Terminal Name	Symbol	Terminal Name
E01	ENGINE GROUND	G1	DISTRIBUTOR	STP	STOP LIGHT SWITCH
E02	ENGINE GROUND	VF2	CHECK CONNECTOR	EGR	EGR VSV
No. 10	INJECTOR (No. 1, 2, 3)	VTA	THROTTLE POSITION SENSOR	A/C	A/C MAGNET SWITCH
No. 20	INJECTOR (No. 4, 5, 6)	NE	DISTRIBUTOR	SPD	SPEED SENSOR
HT1	OXYGEN SENSOR HEATER	IDL	THROTTLE POSITION SENSOR	W	WARNING LIGHT
HT2	OXYGEN SENSOR HEATER	THG	EGR GAS TEMP. SENSOR	FPU	FPU VSV
STJ	COLD START INJECTOR	E11	COMPUTER GROUND	NSW	NEUTRAL START SWITCH
E1	COMPUTER GROUND	OX1	OXYGEN SENSOR	THA	AIR TEMP. SENSOR
T	CHECK CONNECTOR	OX2	OXYGEN SENSOR	STA	STARTER SWITCH
TWS	WATER TEMP. SWITCH	THW	WATER TEMP. SENSOR	VS	AIR FLOW METER
ISC1	ISC MOTOR No. 1 COIL	E2	SENSOR GROUND	AI	AI VSV
ISC2	ISC MOTOR No. 2 COIL	IGF	IGNITER	VC	AIR FLOW METER or THROTTLE POSITION SENSOR
ISC3	ISC MOTOR No. 3 COIL	E22	SENSOR GROUND	BATT	BATTERY
ISC4	ISC MOTOR No. 4 COIL	IGT	IGNITER	+ B	EFI MAIN RELAY
G⊖	DISTRIBUTOR	4WD	4WD INDICATOR	IG S/W	IGNITION SWITCH
VFI	CHECK CONNECTOR	M-REL	EFI MAIN RELAY	+ B1	EFI MAIN RELAY

#### ECU Terminals

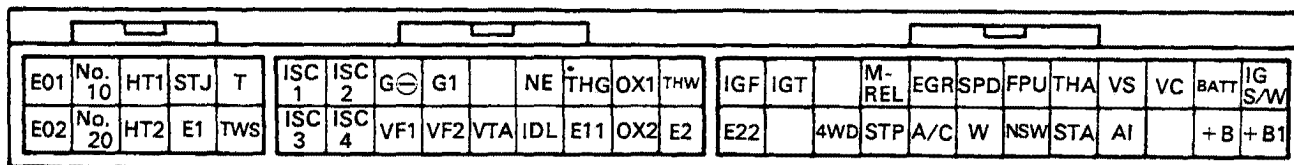

\* California vehicles only

### Voltage at ECU Wiring Connectors

No.	Terminals	Condition		STD Voltage	See page
1	BATT – E1	—		10 – 14	FI-30
	IG S/W – E1	Ignition S/W ON		10 – 14	FI-31
	M-REL – E1				
	+ B (+ B1) – E1				
2	IDL – E2	Ignition S/W ON	Throttle valve open	4 – 6	FI-33
	VC – E2		—	4 – 6	FI-34
	VTA – E2		Throttle valve fully closed	0.1 – 1.0	
			Throttle valve fully open	4 – 5	
3	VC – E22	Ignition S/W ON	—	4 – 6	FI-35
	VS – E22		Measuring plate fully closed	4 – 5	
			Measuring plate fully open	0.02 – 0.08	
		Idling	2 – 4		
		3,000 rpm	0.3 – 1.0		
4	THA – E2	Ignition S/W ON	Intake air temperature 20°C (68°F)	1 – 3	FI-36
5	THW – E2	Ignition S/W ON	Coolant temperature 80°C (176°F)	0.1 – 1.0	FI-37
6	No. 10 E01 – No. 20 E02	Ignition S/W ON		9 – 14	FI-38
7	STA – E1	Cranking		6 – 14	FI-39
8	ISC1 } – E1 ISC4	Ignition S/W ON		9 – 14	FI-40
9	IGT – E1	Idling		0.7 – 1.0	FI-41
10	W – E1	No trouble (“CHECK” engine warning light off) and engine running		8 – 14	FI-42
11	A/C – E1	Air conditioning ON		10 – 14	FI-43

#### ECU Terminals

E01	No. 10	HT1	STJ	T	ISC 1	ISC 2	G⊖	G1		NE	TH	GX1	THW	IGF	IGT		M-REL	EGR	SPD	FPU	THA	VS	VC	BATT	IG S/W
E02	No. 20	HT2	E1	TWS	ISC 3	ISC 4	VF1	VF2	VTA	IDL	E11	OX2	E2	E22	4WD	STP	A/C	W	NSV	STA	AI			+ B	+ B1

\* California vehicles only

No.	Terminals	Trouble	Condition	STD Voltage
1	BATT – E1	No voltage	—	10 – 14 V
	IG S/W – E1	No voltage	Ignition switch ON	10 – 14 V
	M-REL – E1	No voltage	Ignition switch ON	10 – 14 V
	+ B (+ B1) – E1	No voltage	Ignition switch ON	10 – 14 V

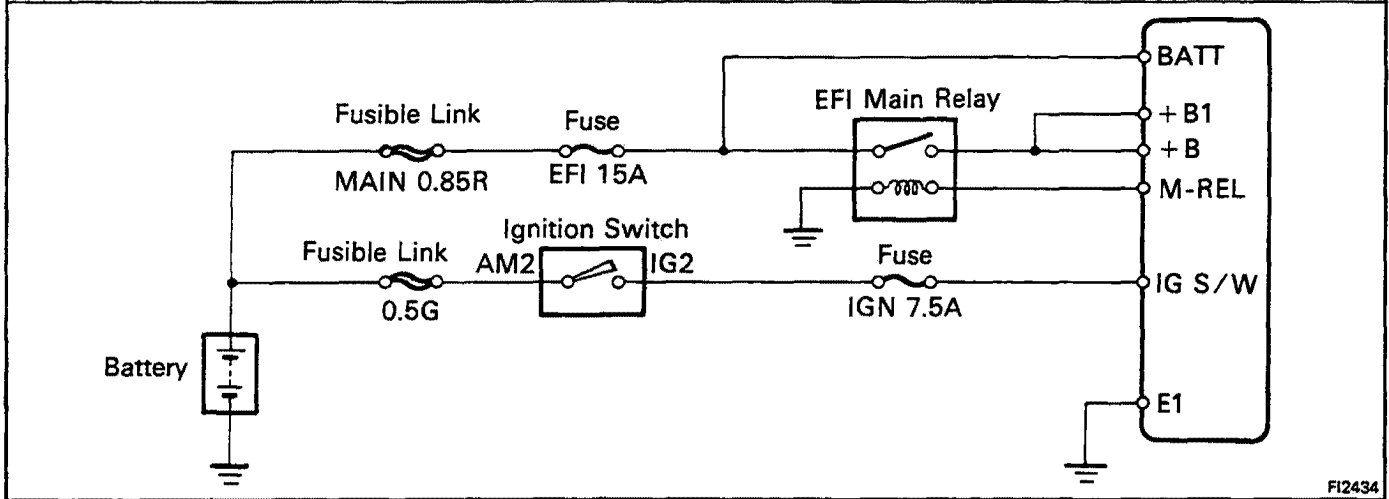

FI2434

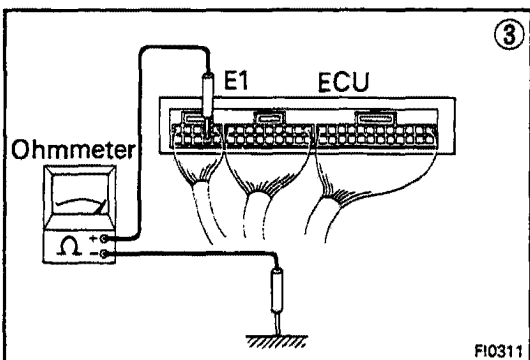
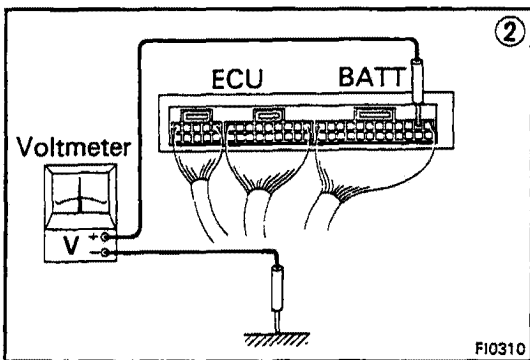
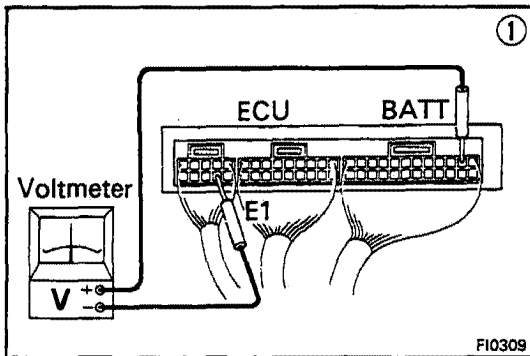

• BATT – E1

```

    graph TD
      A["① There is no voltage between ECU terminals BATT and E1."] --> B["② Check that there is voltage between ECU terminal BATT and body ground."]
      B -- NO --> C["Check fuse and fusible link."]
      B -- OK --> D["③ Check wiring between ECU terminal E1 and body ground."]
      C -- BAD --> E["Replace."]
      C -- OK --> F["Check wiring between ECU terminal and battery."]
      D -- OK --> F
      D -- BAD --> G["Repair or replace."]
      F -- BAD --> H["Replace."]
      F -- OK --> I["Try another ECU."]
      I --> G
  
```

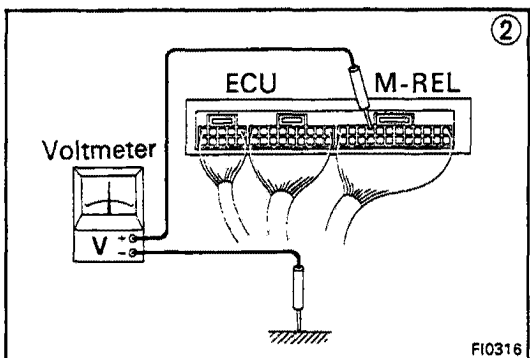
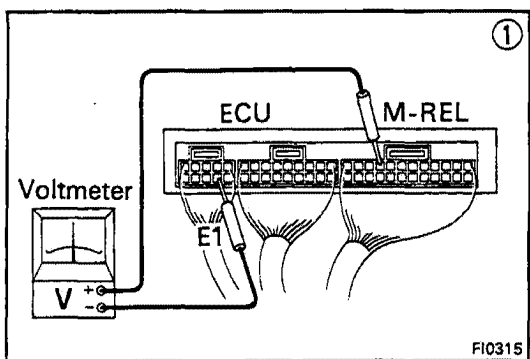
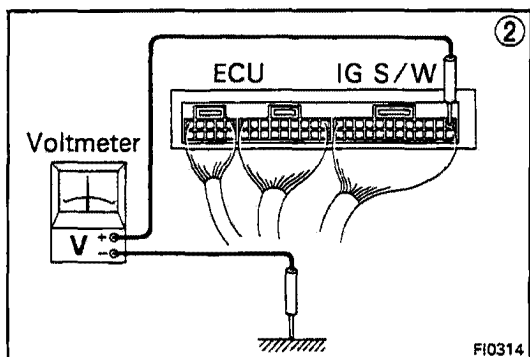
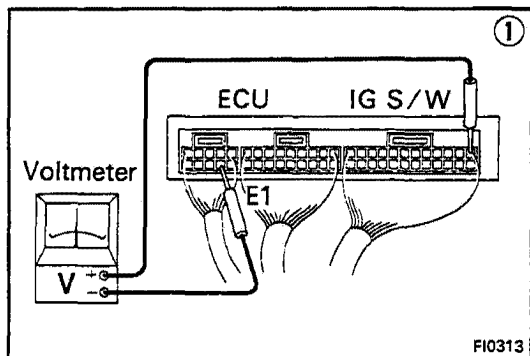

• IG S/W – E1

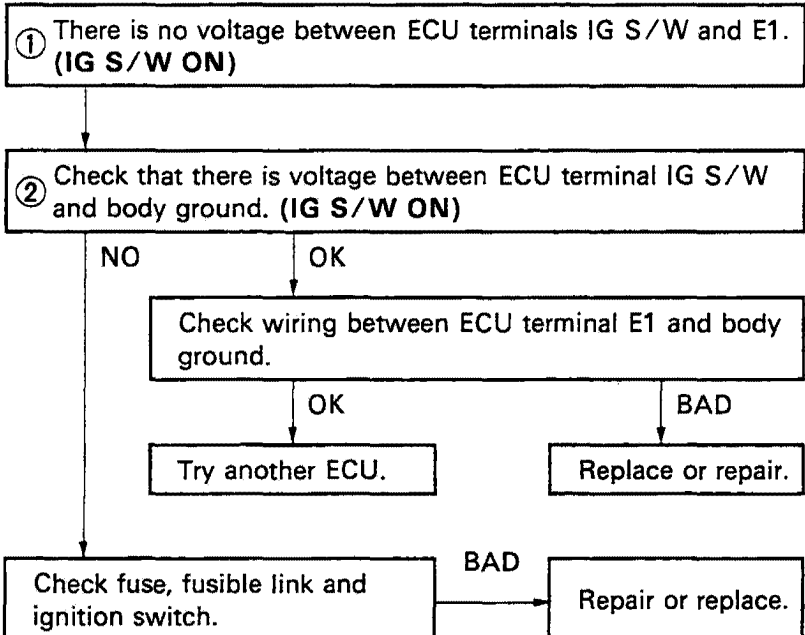

• M-REL – E1

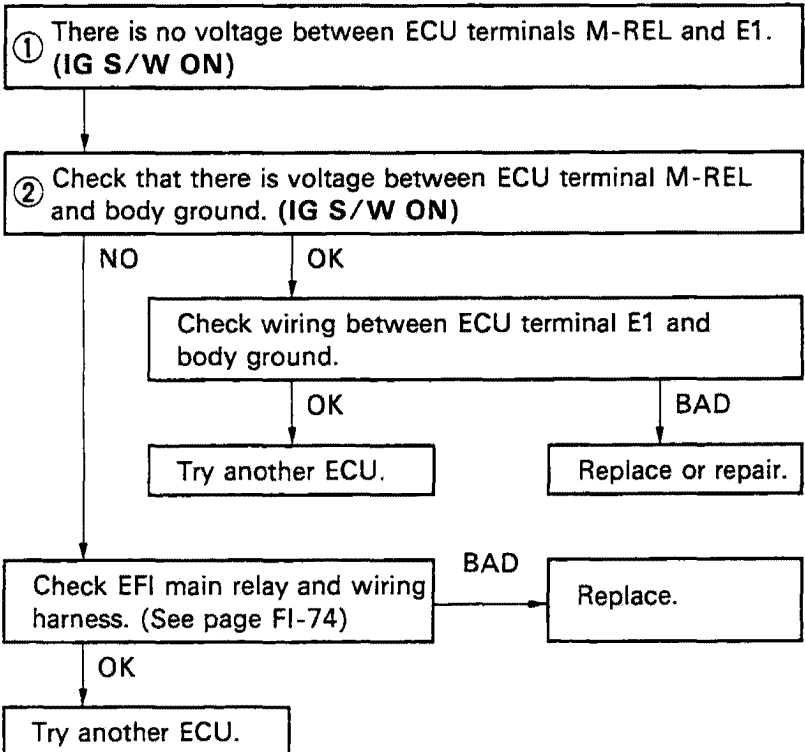

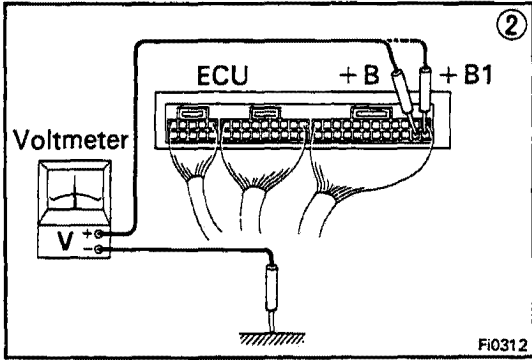
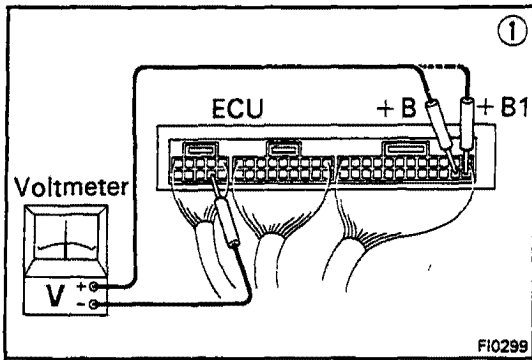

• + B (+ B1)

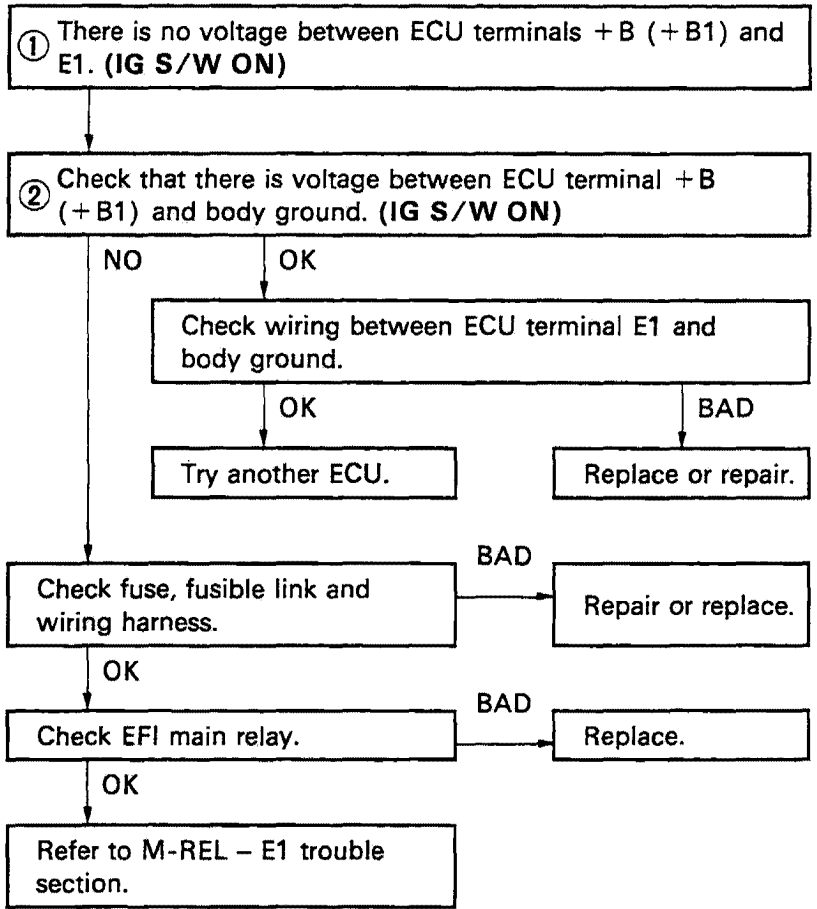

No.	Terminals	Trouble	Condition	STD Voltage	
2	IDL – E2	No voltage	Ignition switch ON	Throttle valve open	4 – 6 V
	VC – E2			—	4 – 6 V
	VTA – E2			Throttle valve fully closed	0.1 – 1.0 V
				Throttle valve fully open	4 – 5 V

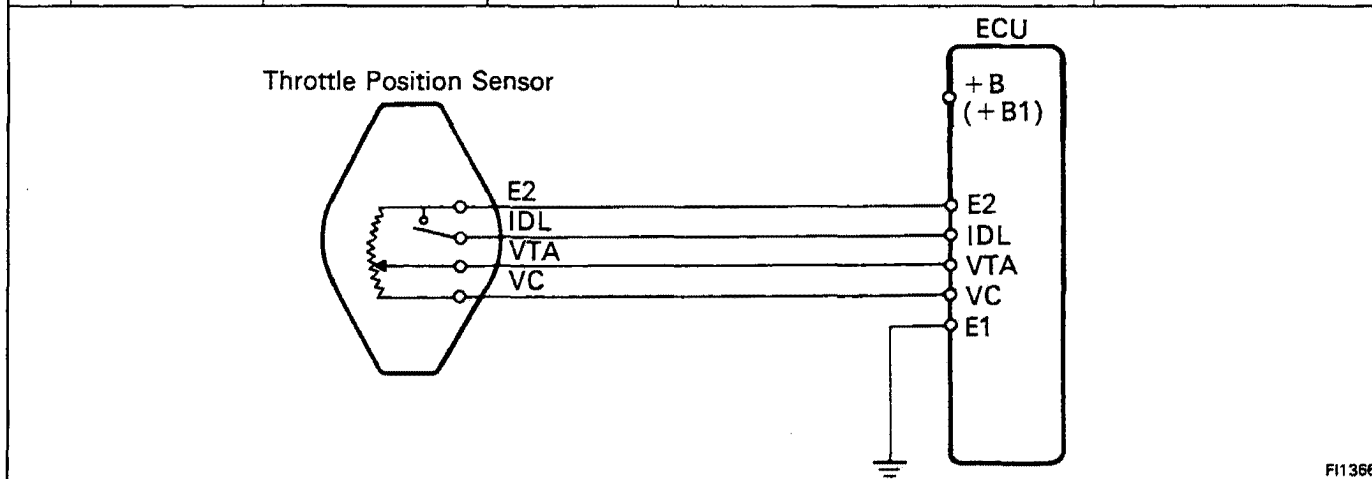

FI1366

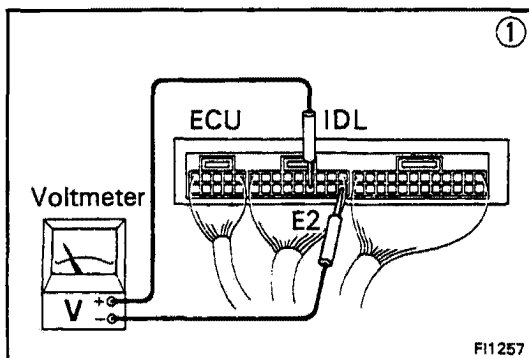

FI1257

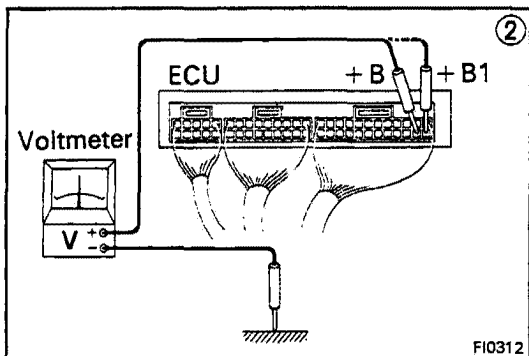

FI0312

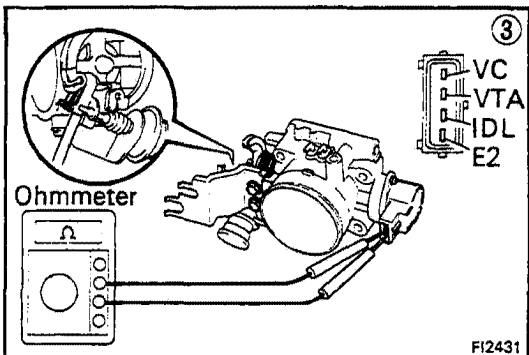

FI2431

• IDL – E2

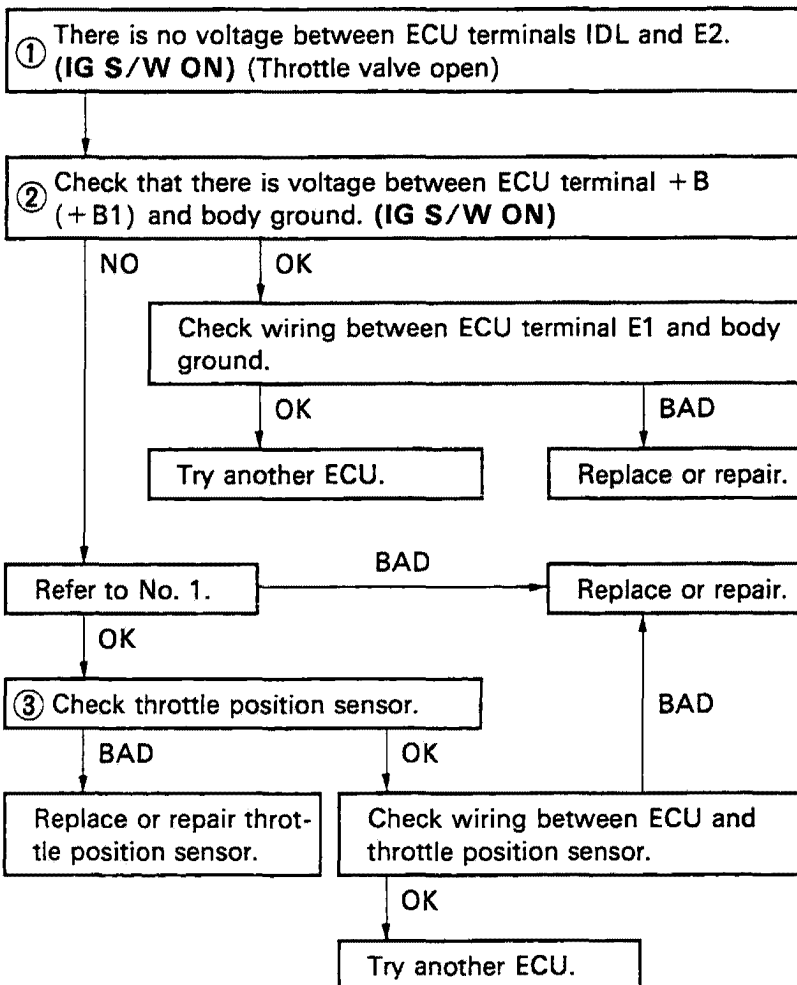

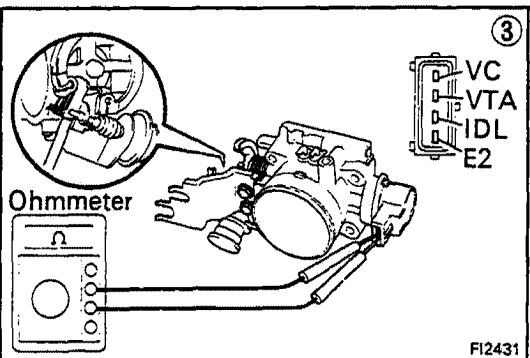
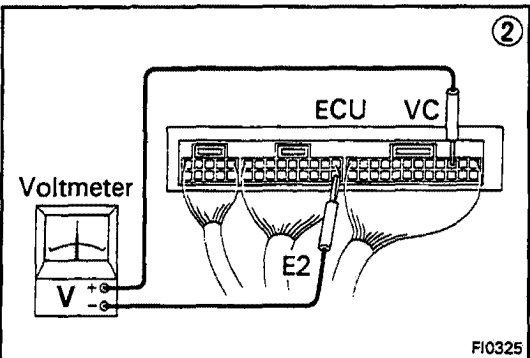
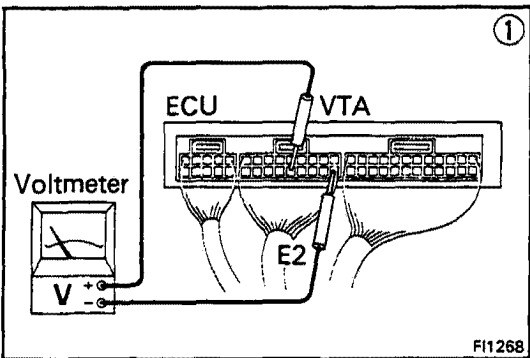
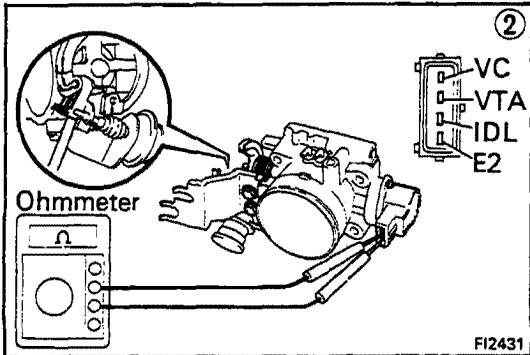
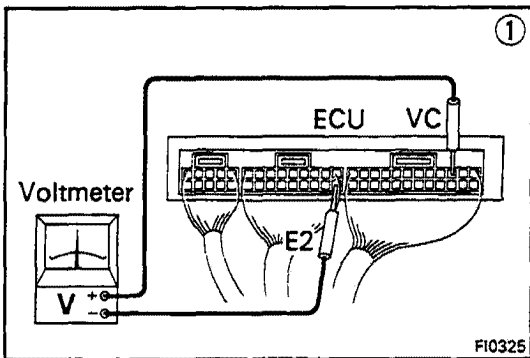

• VC – E2

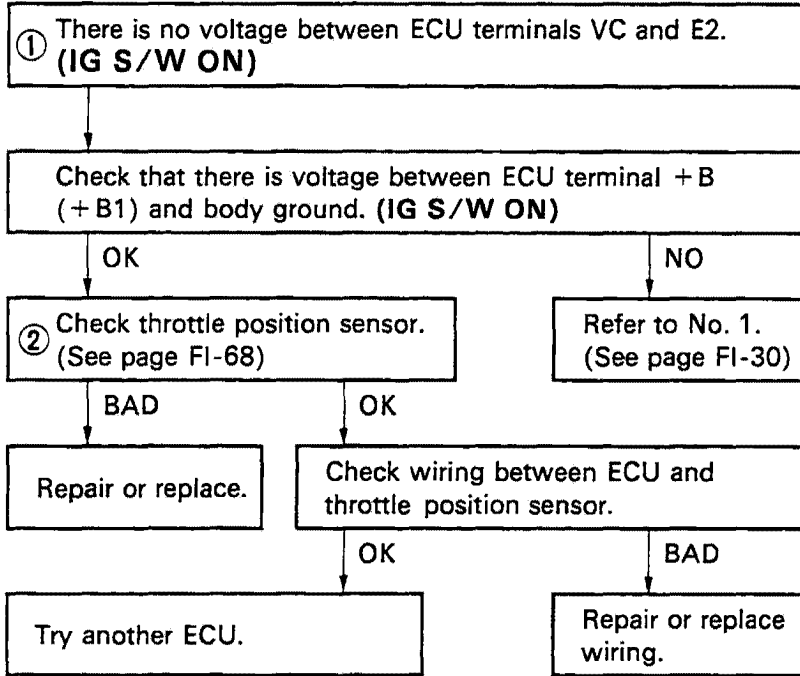

• VTA – E2

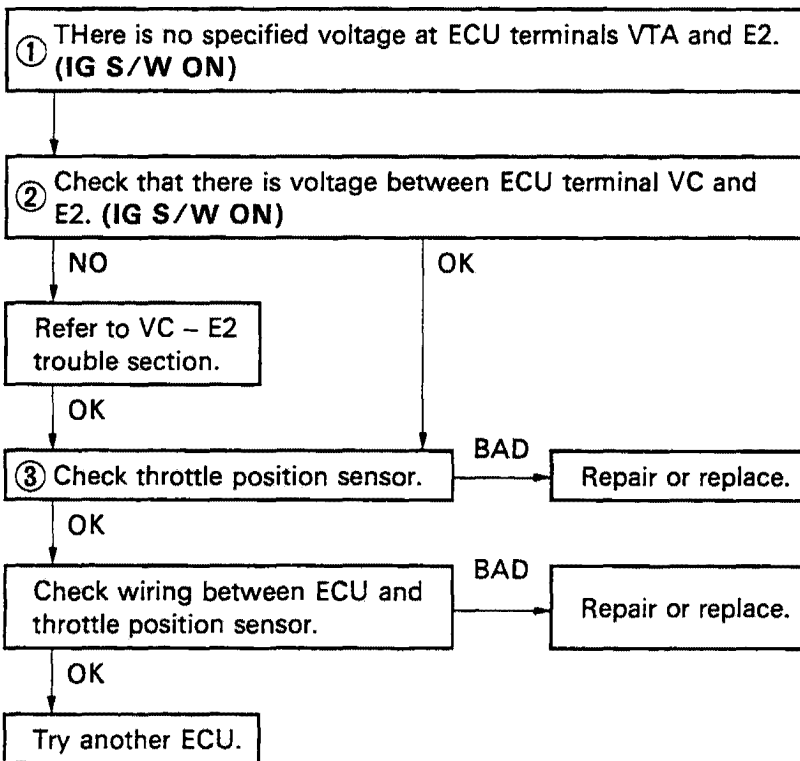

No.	Terminals	Trouble	Condition	STD Voltage	
3	VC – E22	No voltage	Ignition S/W ON	—	4 – 6 V
	VS – E22			Measuring plate fully closed	4 – 5 V
	VS – E22			Measuring plate fully open	0.02 – 0.08 V
	VS – E22		Idling	—	2 – 4 V
	VS – E22		3,000 rpm	—	0.3 – 1.0 V

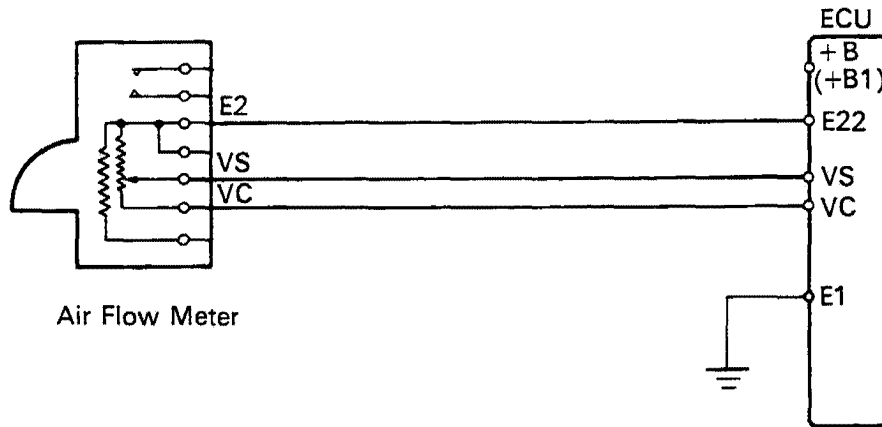

FI1269

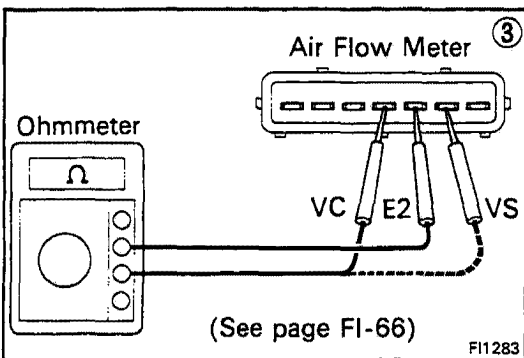
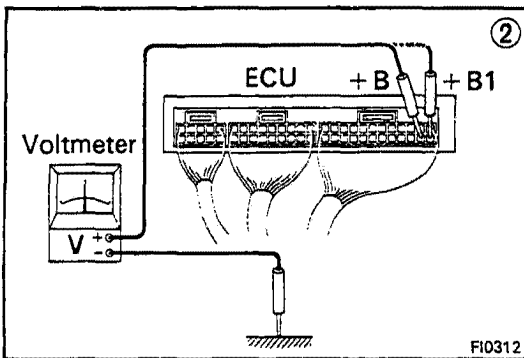
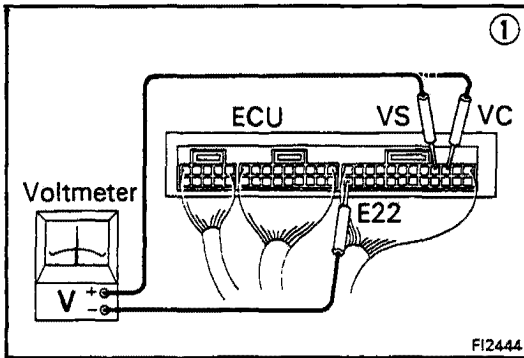

```

    graph TD
      Step1["① There is no voltage between ECU terminals VC or VS and E22. (IG S/W ON)"]
      Step2["② Check that there is voltage between ECU terminal + B (+ B1) and body ground. (IG S/W ON)"]
      Step3["③ Check air flow meter. (See page FI-66)"]
      Step4["Check wiring between ECU terminal E1 and body ground."]
      Step5["Check wiring between ECU and air flow meter."]
      Step6["Try another ECU."]
      Step7["Repair or replace."]
      Step8["Repair or replace."]

      Step1 --> Step2
      Step2 -- NO --> Step7
      Step2 -- OK --> Step4
      Step4 -- BAD --> Step7
      Step4 -- OK --> Step3
      Step3 -- BAD --> Step7
      Step3 -- OK --> Step5
      Step5 -- BAD --> Step8
      Step5 -- OK --> Step6
  
```

No.	Terminals	Trouble	Condition		STD Voltage
4	THA – E22	No voltage	Ignition switch ON	Intake air temperature 20°C (68°F)	1 – 3 V

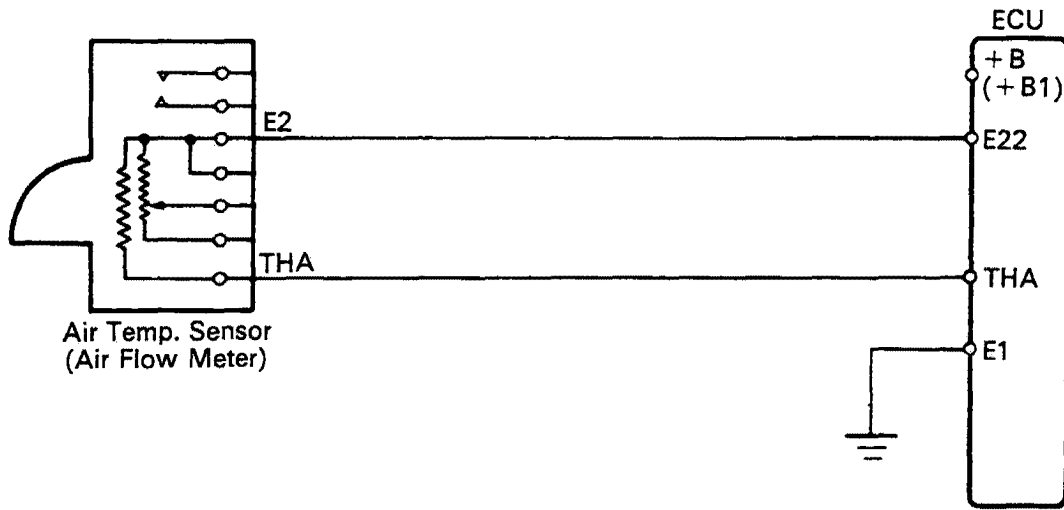

FI1272

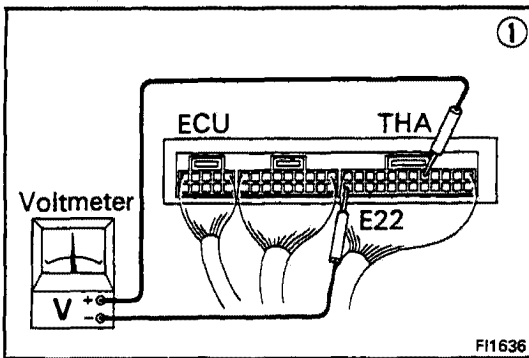

① There is no voltage between ECU terminals THA and E22. (IG S/W ON)

② Check that there is voltage between ECU terminal + B (+ B1) and body ground. (IG S/W ON)

OK

NO

Refer to No. 1. (See page FI-30)

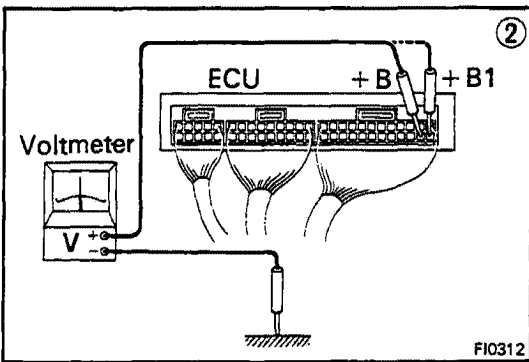

Check wiring between ECU terminal E1 and body ground.

OK

BAD

③ Check air temp. sensor. (See page FI-66)

Repair or replace.

BAD

OK

Replace air flow meter.

Check wiring between ECU and air temp. sensor.

OK

BAD

Try another ECU.

Repair or replace.

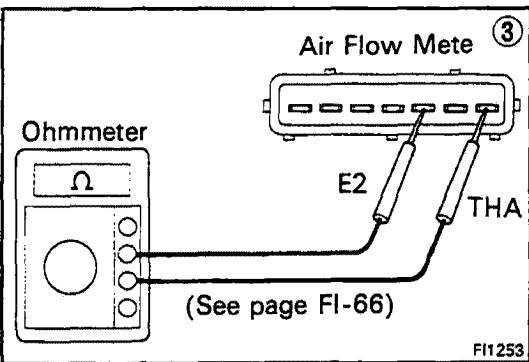

No.	Terminals	Trouble	Condition	STD Voltage
5	THW – E2	No voltage	Ignition switch ON Coolant temperature 80°C (176°F)	0.1 – 1.0 V

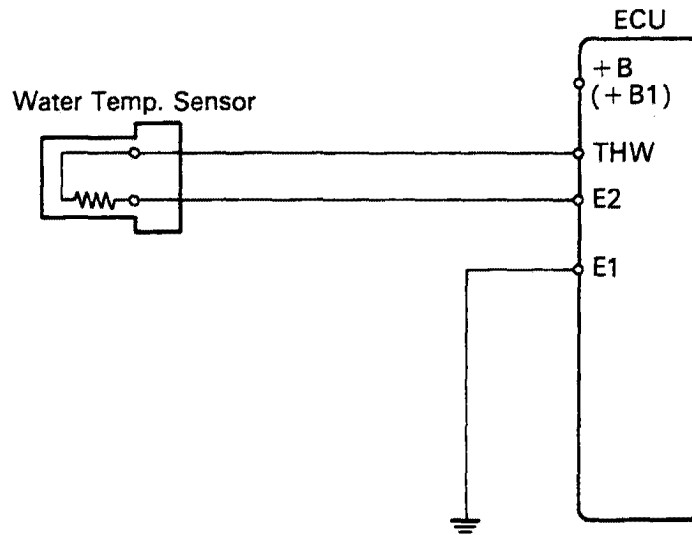

FI0487

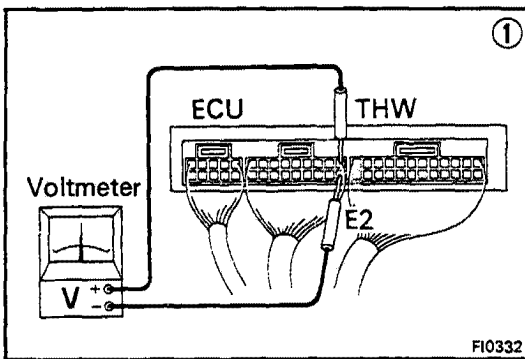

FI0332

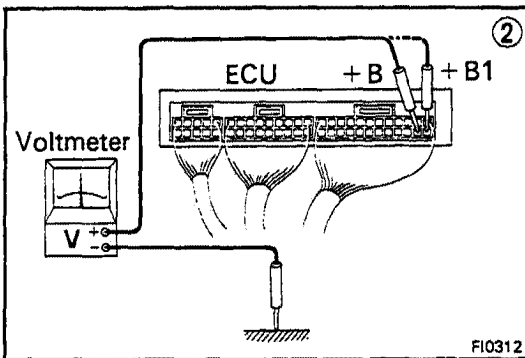

FI0312

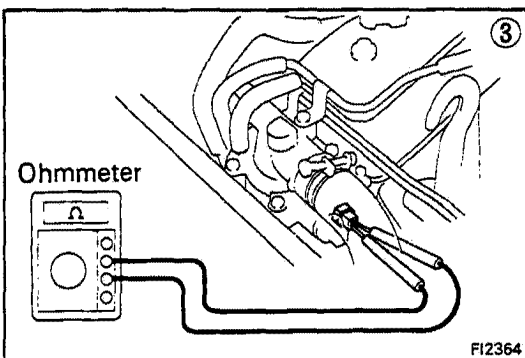

FI2364

```

    graph TD
      Step1["① There is no voltage between ECU terminals THW and E2.  
(IG S/W ON)"]
      Step2["② Check that there is voltage between ECU terminal + B  
(+ B1) and body ground. (IG S/W ON)"]
      Step3["③ Check water temp. sensor.  
(See page FI-77)"]
      Step4["Check wiring between ECU terminal E1 and  
body ground."]
      Step5["Check wiring between ECU and  
water temp. sensor."]
      Step6["Try another ECU."]
      Step7["Repair or replace."]
      Step8["Repair or replace."]

      Step1 --> Step2
      Step2 -- OK --> Step4
      Step2 -- NO --> Step7
      Step4 -- OK --> Step3
      Step4 -- BAD --> Step7
      Step3 -- BAD --> Step7
      Step3 -- OK --> Step5
      Step5 -- OK --> Step6
      Step5 -- BAD --> Step8
  
```

No.	Terminals	Trouble	Condition	STD Voltage
6	No. 10 – E01 No. 20 – E02	No voltage	Ignition switch ON	9 – 14 V

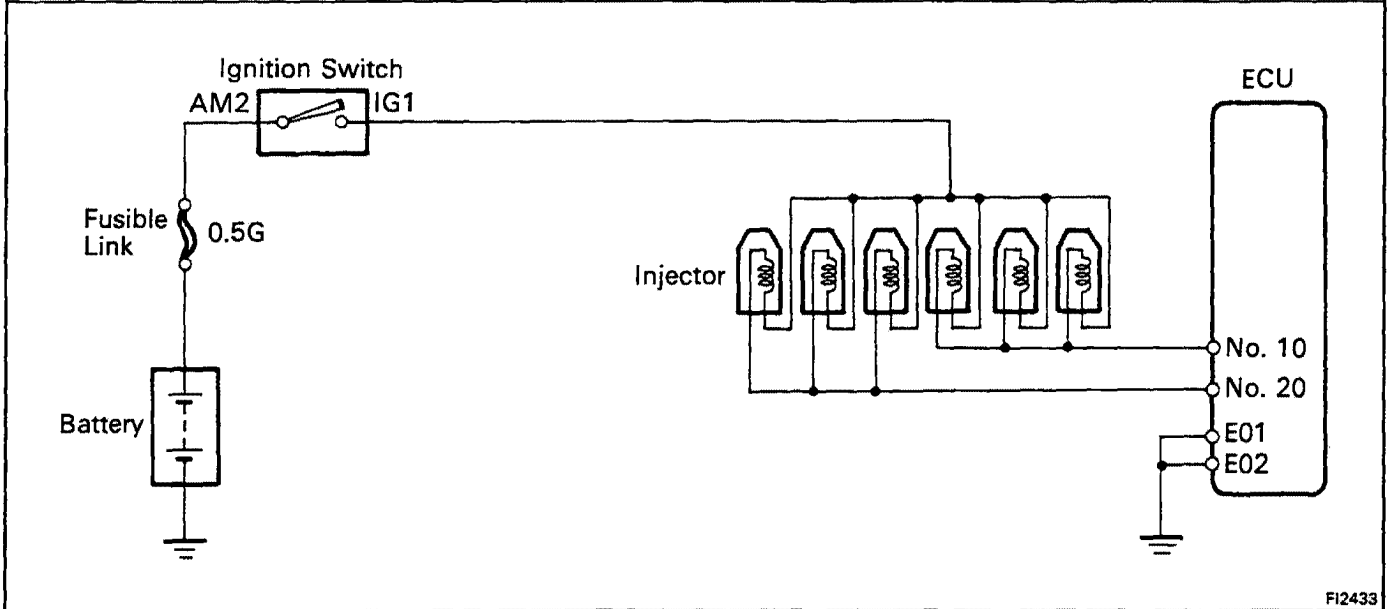

FI2433

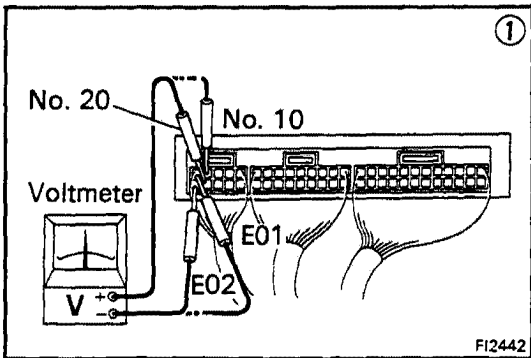

FI2442

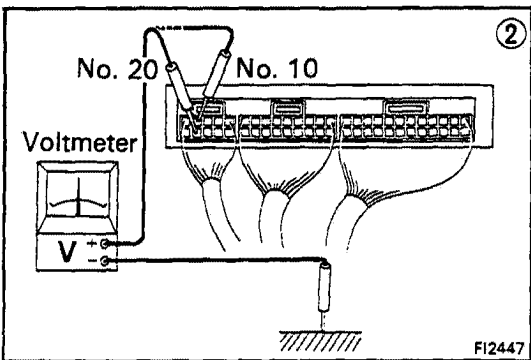

FI2447

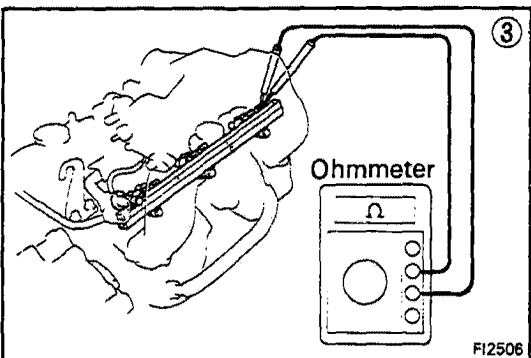

FI2506

```

    graph TD
      Step1["① There is no voltage between ECU terminal No. 10 and/or No. 20 and E01 and/or E02. (IG S/W ON)"]
      Step2["② Check that there is voltage between ECU terminal (No. 10 or No. 20) and body ground."]
      Step3["③ Check resistance of magnetic coil in each injector. STD resistance: Approx. 13.8 Ω"]
      
      Step1 --> Step2
      Step2 -- NO --> CheckWiring["Check wiring between ECU terminal E01 and/or E02 and body ground."]
      Step2 -- OK --> CheckFusible["Check fusible link and ignition switch."]
      CheckWiring -- OK --> TryECU["Try another ECU."]
      CheckWiring -- BAD --> RepairECU["Repair or replace."]
      CheckFusible -- BAD --> RepairFusible["Repair or replace."]
      CheckFusible -- OK --> Step3
      
      Step3 -- BAD --> ReplaceInjector["Replace injector."]
      Step3 -- OK --> CheckWiringECU["Check wiring between ECU terminal No. 10 and/or No. 20 and battery."]
      CheckWiringECU -- BAD --> RepairWiring["Repair or replace."]
  
```

No.	Terminals	Trouble	Condition	STD Voltage
7	STA – E1	No voltage	Cranking	6 – 14 V

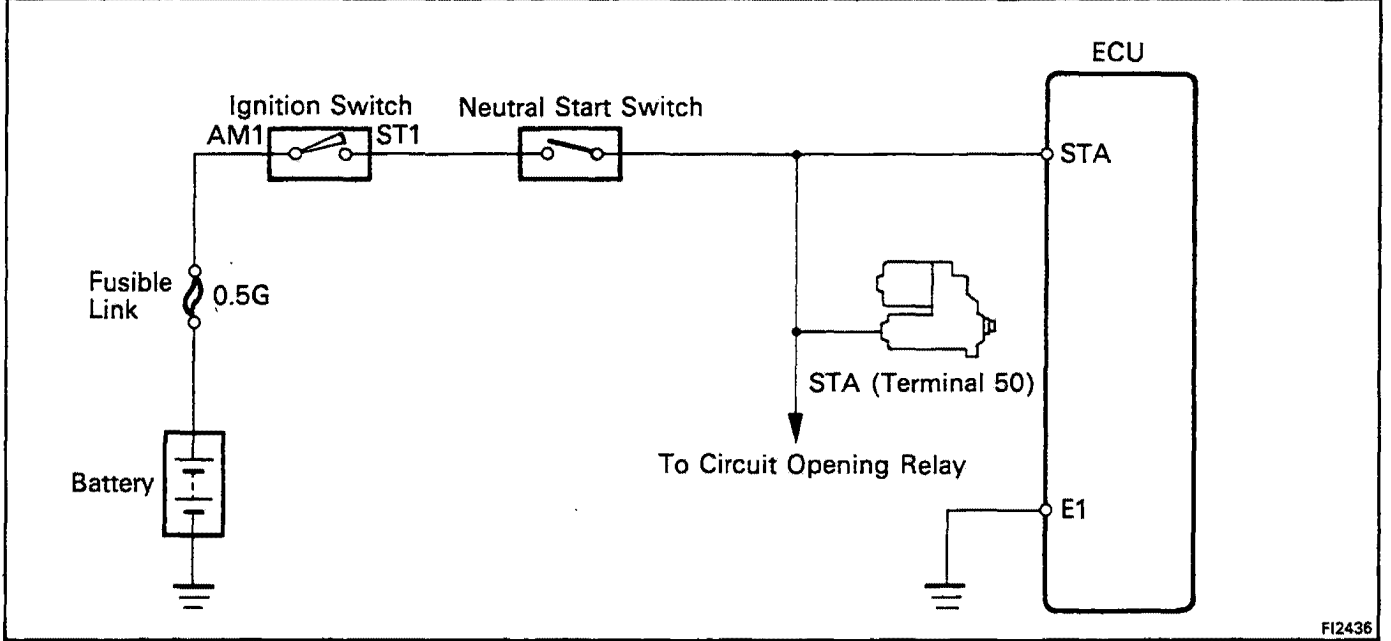

FI2436

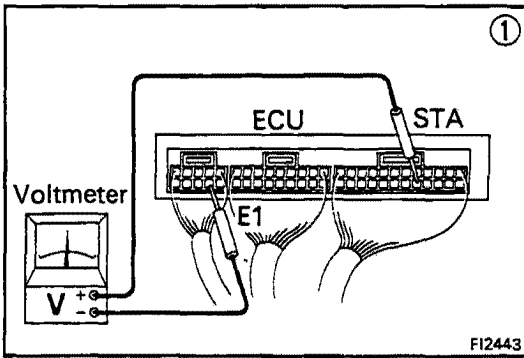

FI2443

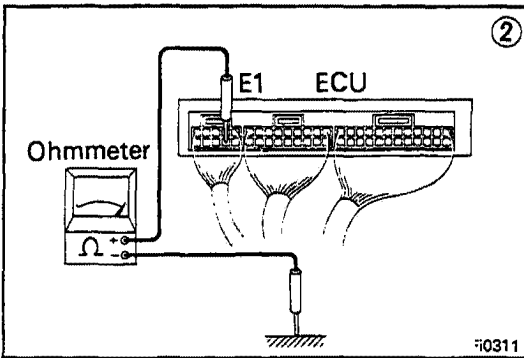

FI0311

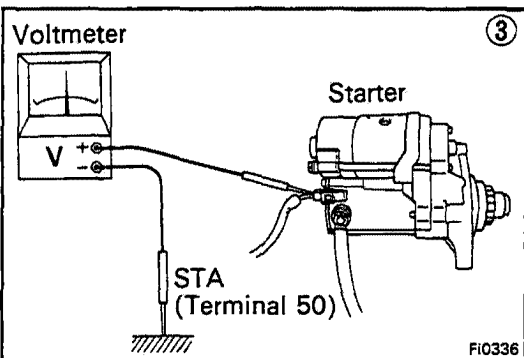

FI0336

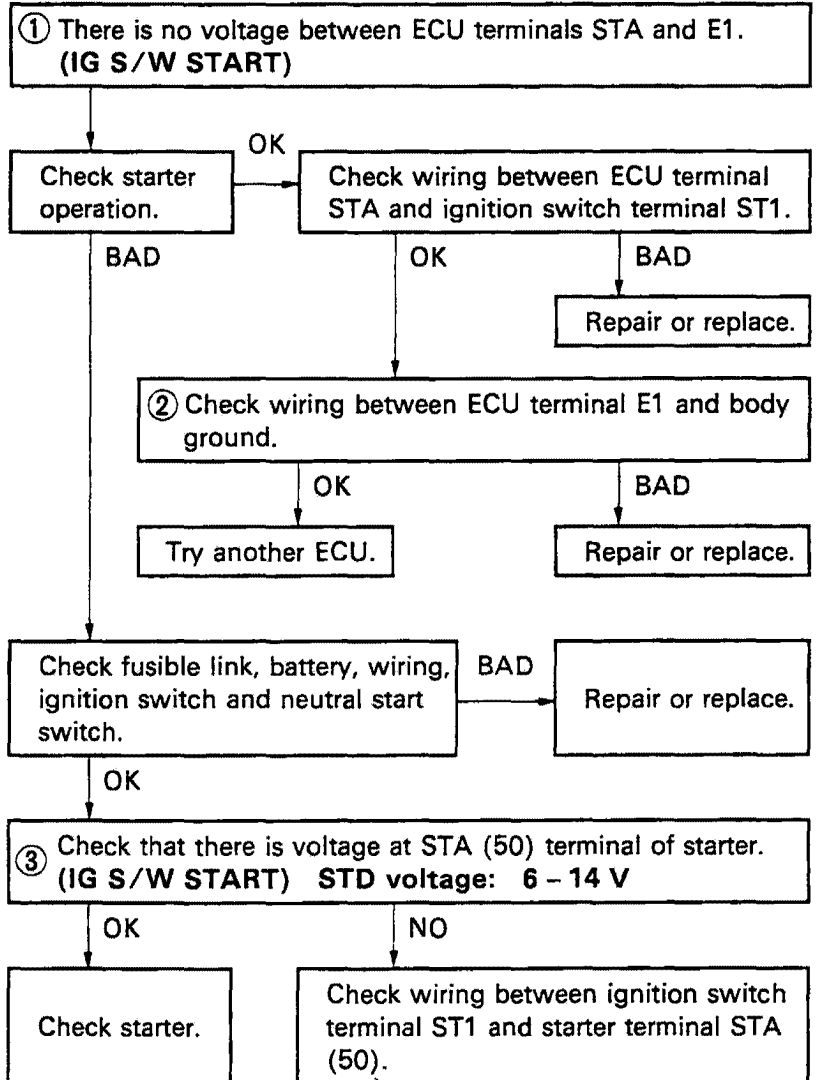

No.	Terminals	Trouble	Condition	STD Voltage
8	ISC1 ~ ISC4 – E1	No voltage	Ignition switch ON	9 – 14 V

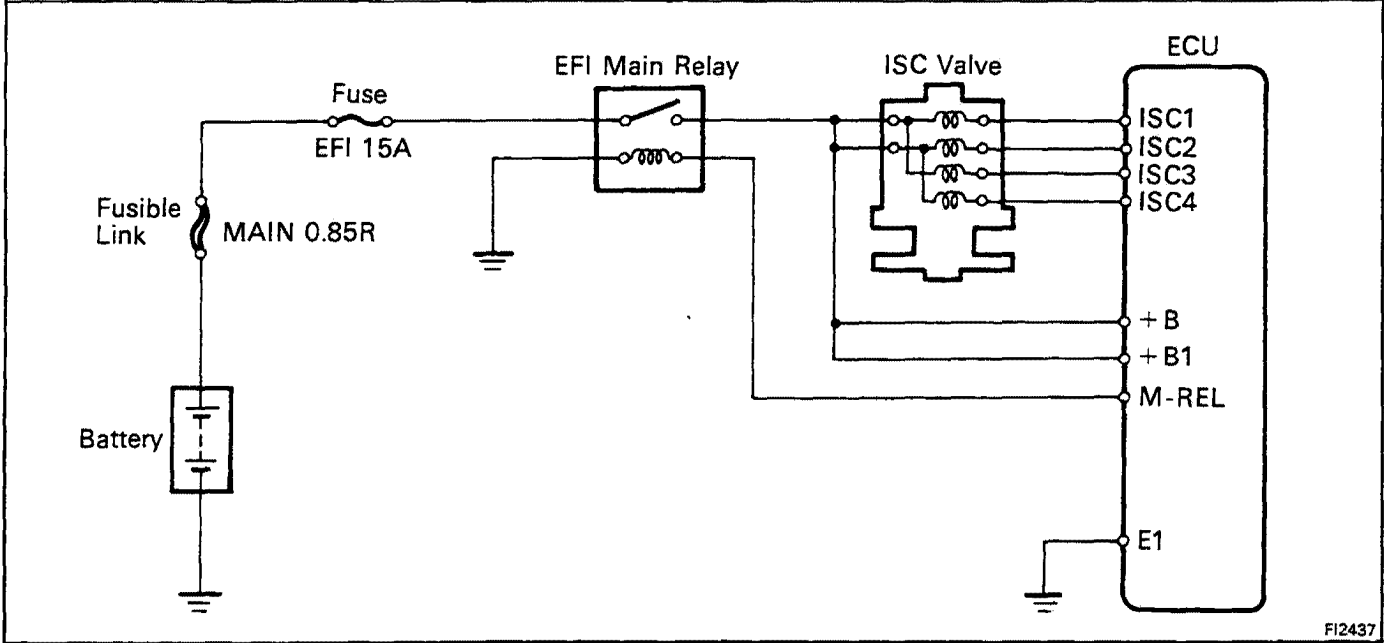

FI2437

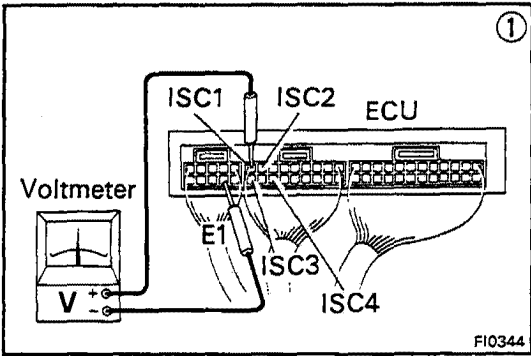

① There is no voltage between ECU terminals ISC1 ~ ISC4 and E1. (IG S/W ON)

② Check that there is voltage between ECU terminal + B (+ B1) and body ground. (IG S/W ON)

OK

NO

Refer to No. 1. (See page FI-30)

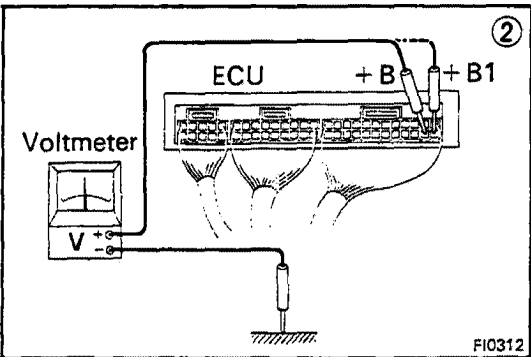

Check wiring between ECU terminal E1 and body ground.

OK

BAD

Repair or replace.

③ Check ISC valve. (See page FI-71)

BAD

OK

Replace ISC valve.

Check wiring between ECU and EFI main relay.

OK

BAD

Try another ECU.

Repair or replace.

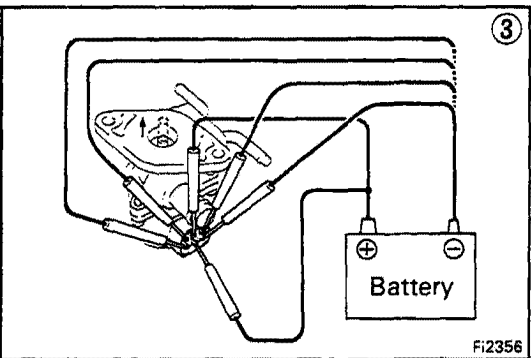

No.	Terminals	Trouble	Condition	STD Voltage
9	IGT – E1	No voltage	Idling	0.7 – 1.0 V

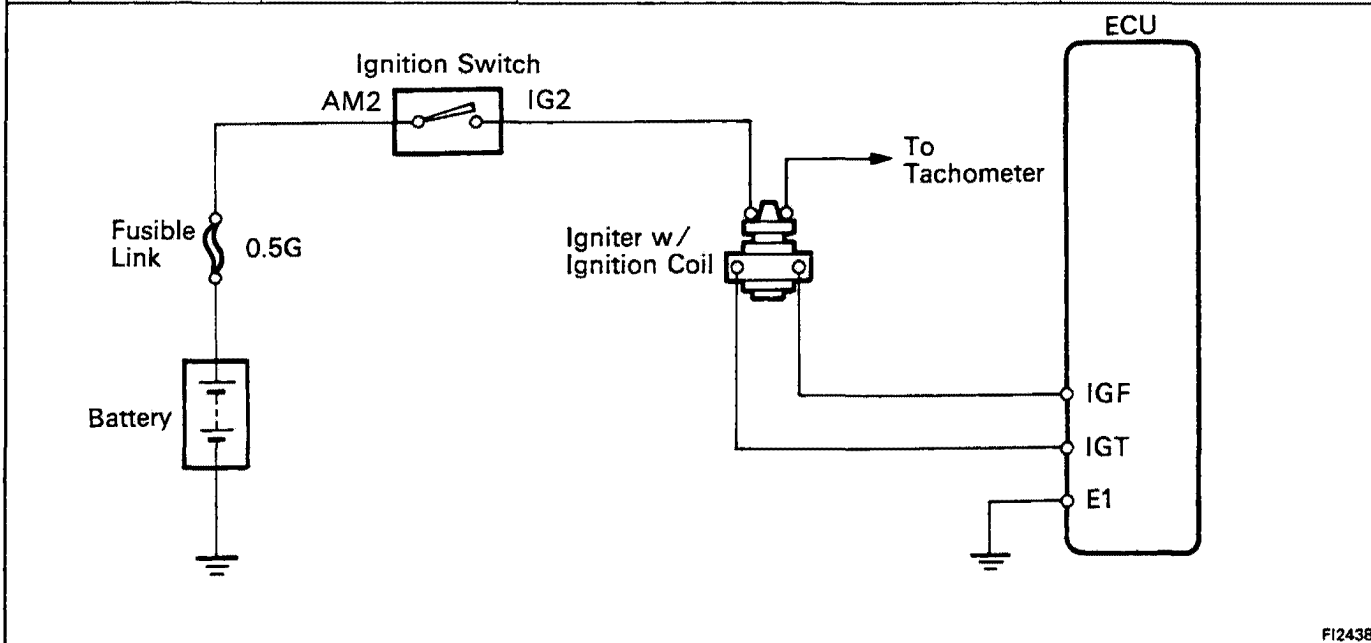

FI2438

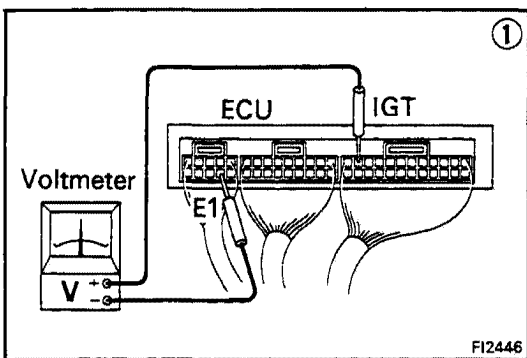

FI2446

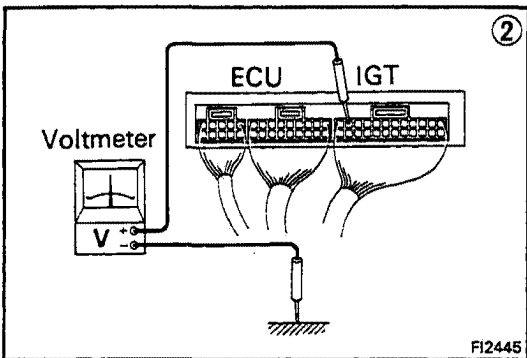

FI2445

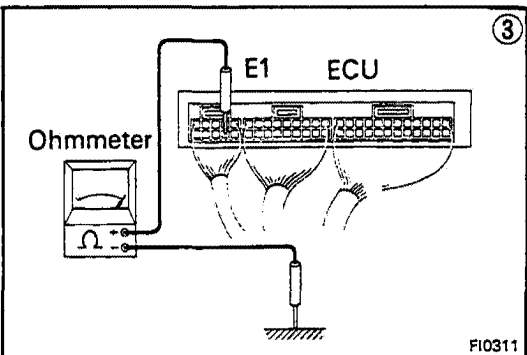

FI0311

```

    graph TD
      A["① There is no voltage between ECU terminals IGT and E1. (Idling)"] --> B["② Check that there is voltage between ECU terminal IGT and body ground. (Idling)"]
      B -- NO --> C["Check fusible link and ignition switch."]
      B -- OK --> D["③ Check wiring between ECU terminal E1 and body ground."]
      D -- BAD --> E["Repair or replace."]
      D -- OK --> F["Try another ECU."]
      C -- OK --> G["Check distributor. (See page IG-7)"]
      C -- BAD --> H["Repair or replace."]
      G -- OK --> I["Check wiring between ECU and battery."]
      G -- BAD --> J["Repair or replace."]
      I -- OK --> K["Check igniter. (See page IG-7)"]
      I -- BAD --> L["Repair or replace."]
      K -- OK --> M[" "]
      K -- BAD --> N["Repair or replace."]
  
```

No.	Terminals	Trouble	Condition	STD Voltage
10	W – E1	No voltage	No trouble ("CHECK" engine warning light off) and engine running	8 – 14 V

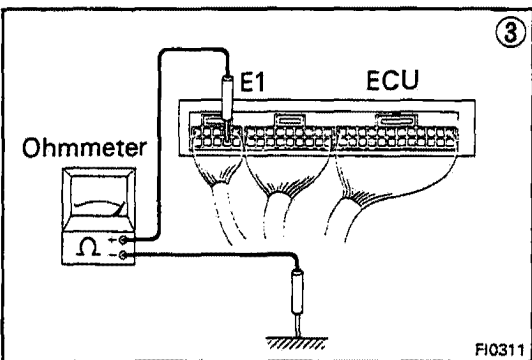
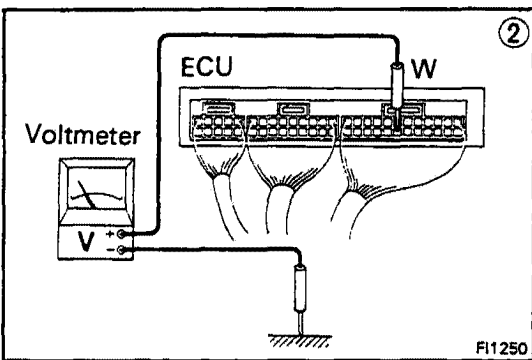
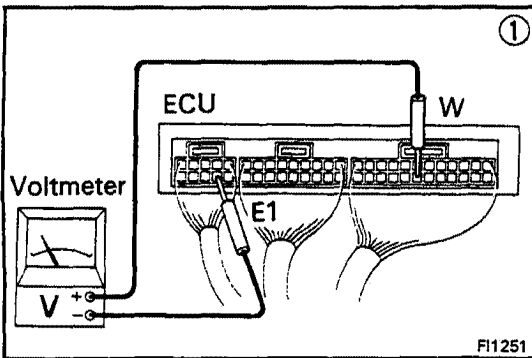
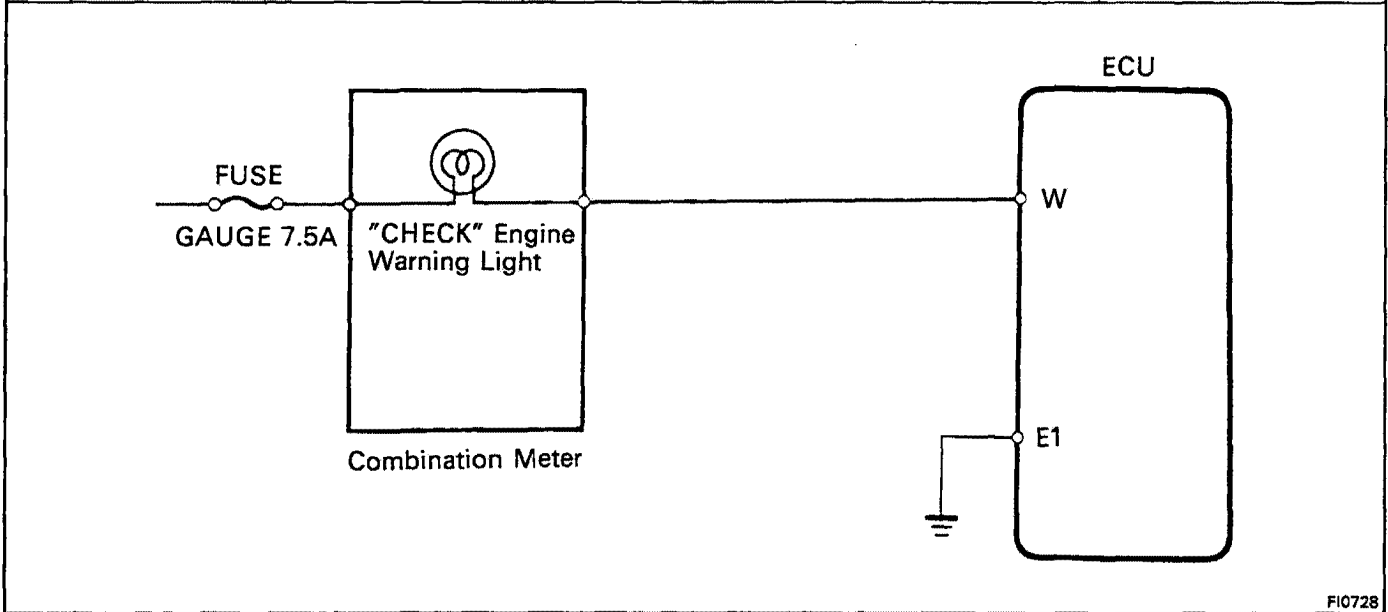

```

graph TD
    Step1["① There is no voltage between ECU terminals W and E1. (Idling)"] --> Step2["② Check that there is voltage between ECU terminal W and body ground."]
    Step2 -- NO --> Step3["③ Check wiring between ECU terminal E1 and body ground."]
    Step2 -- OK --> Step4["Check GAUGE fuse (7.5A) and 'CHECK' engine warning light."]
    Step3 -- OK --> Step5["Try another ECU."]
    Step3 -- BAD --> Step6["Repair or replace."]
    Step4 -- OK --> Step7["Check wiring between ECU terminal W and fuse."]
    Step4 -- BAD --> Step8["Repair or replace."]
    Step8 -- Fuse blows again --> Step7
    Step7 -- BAD --> Step9["Repair or replace."]
    
```

No.	Terminals	Trouble	Condition	STD Voltage
11	A/C – E1	No voltage	Air conditioning ON	10 – 14 V

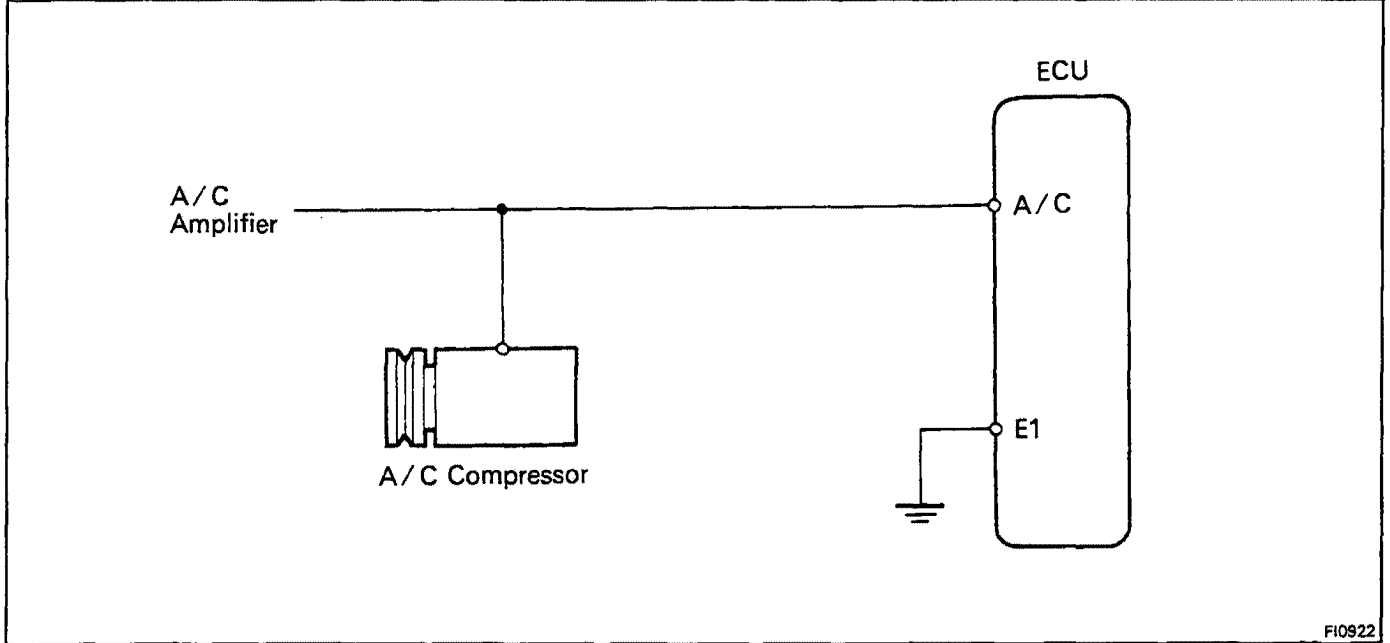

FI0922

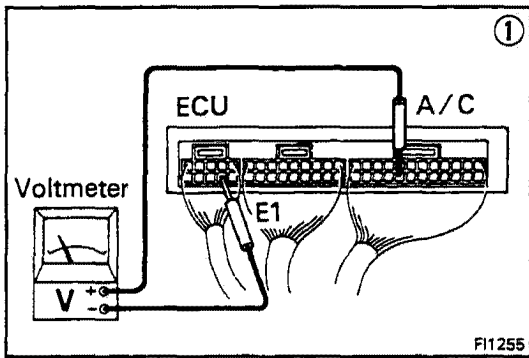

FI1255

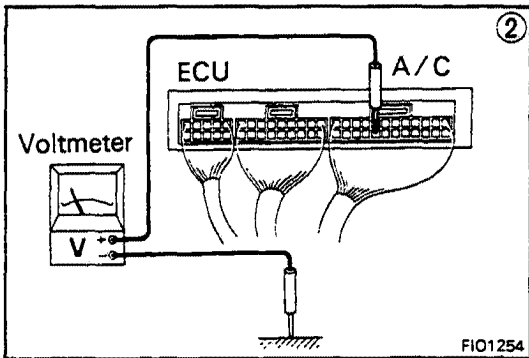

FI01254

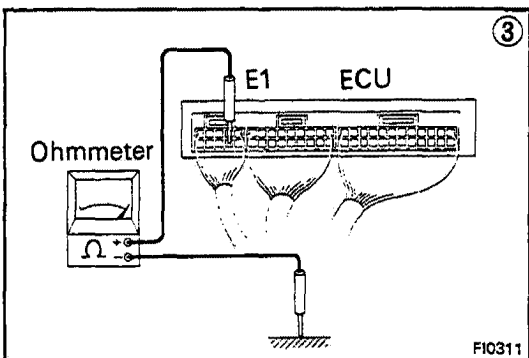

FI0311

```

    graph TD
      Step1["① There is no voltage between ECU terminals A/C and E1.  
(Air conditioning ON)"] --> Step2["② Check that there is voltage between ECU terminal A/C and  
body ground."]
      Step2 -- NO --> Step3["③ Check wiring between ECU terminal E1 and body  
ground."]
      Step2 -- OK --> CheckComp["Check compressor running."]
      Step3 -- OK --> CheckComp
      Step3 -- BAD --> RepairECU["Repair or replace."]
      CheckComp -- OK --> CheckA/C["Check wiring between ECU  
terminal A/C and  
amplifier."]
      CheckComp -- BAD --> CheckAmp["Check that there is voltage between  
amplifier terminal and body ground."]
      CheckA/C -- BAD --> RepairA/C["Repair or replace."]
      CheckAmp -- BAD --> RepairAmp["Repair or replace."]
      CheckAmp -- OK --> CheckWiring["Check wiring between amplifier  
and ECU or compressor."]
      CheckWiring -- BAD --> RepairWiring["Repair or replace."]
      CheckWiring -- OK --> End[" "]
  
```

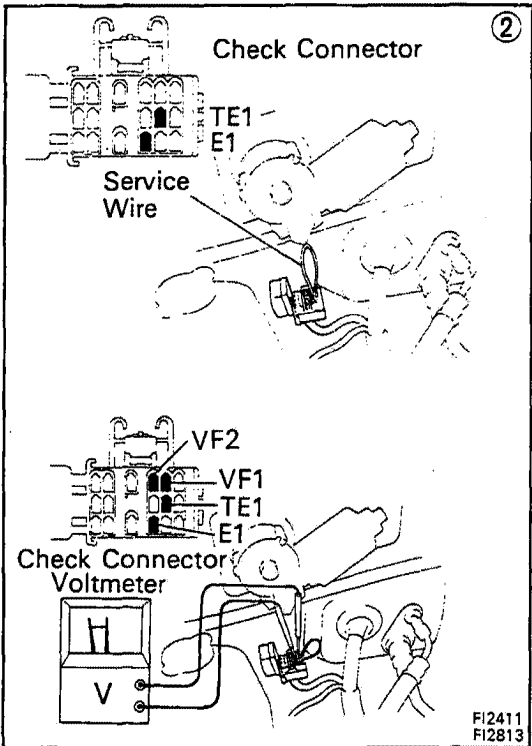
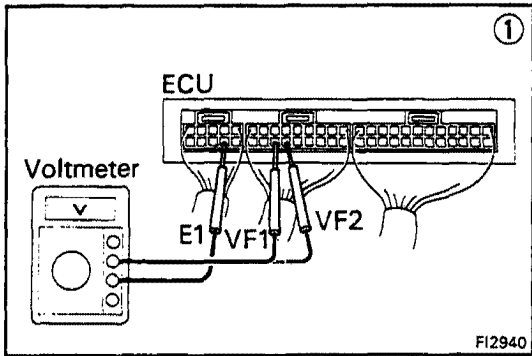
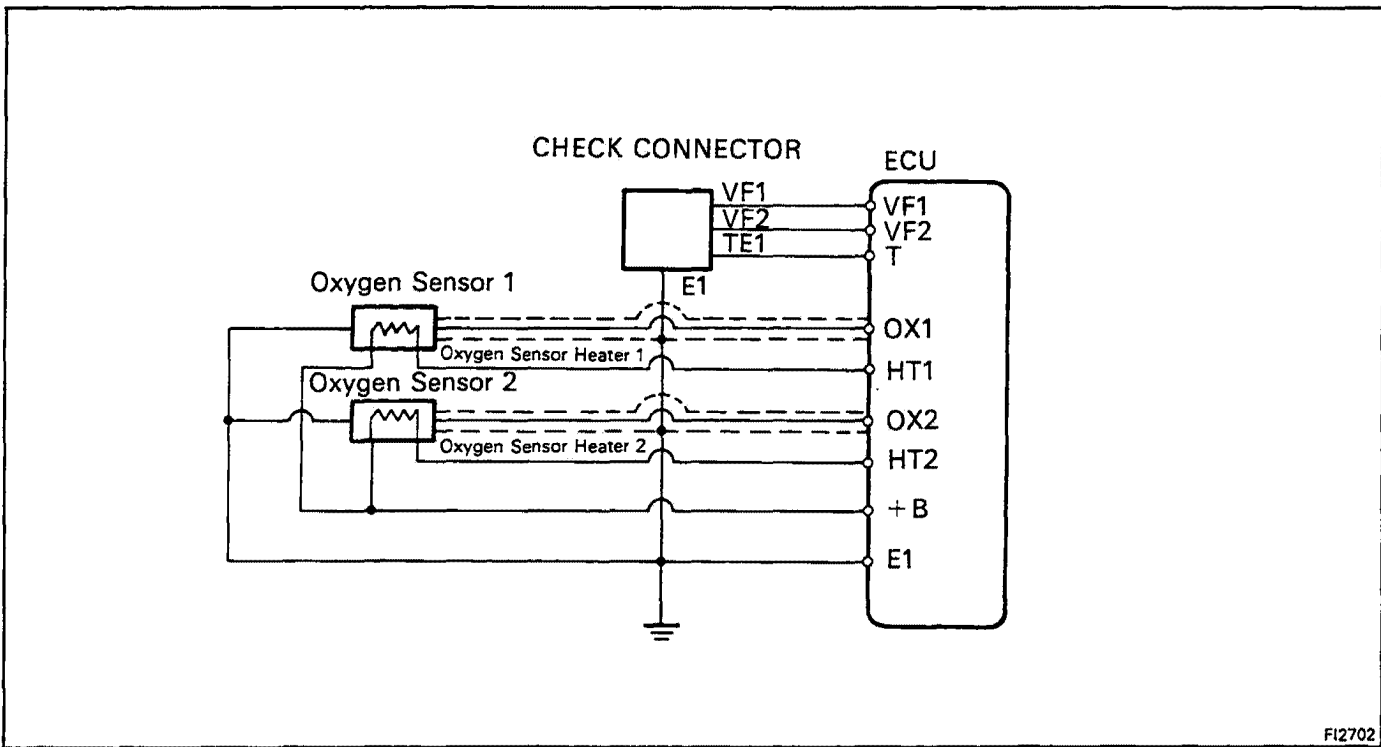

```

    graph TD
      A["① There is no voltage between ECU terminals VF1 or VF2 and E1."] --> B["Check that there is specified voltage between ECU terminal VF1 or VF2 and body ground."]
      B -- NO --> C["Check wiring between ECU terminal E1 and body ground."]
      B -- OK --> D["Check for suction of air into exhaust system."]
      C -- OK --> E["Try another ECU."]
      C -- BAD --> F["Repair or replace."]
      D -- BAD --> G["Repair air suction."]
      D -- OK --> H["Check for air leak from air intake system."]
      H -- BAD --> I["Repair air leak."]
      H -- OK --> J["Check spark plugs."]
      J -- BAD --> K["Repair or replace."]
      J -- OK --> L["Check distributor and ignition system."]
      L -- BAD --> M["Repair or replace."]
      L -- OK --> N["Check fuel pressure."]
      N -- BAD --> O["Repair or replace."]
      N -- OK --> P["Check injectors."]
      P -- BAD --> Q["Repair or replace."]
      P -- OK --> R["Check cold start injector. *"]
      R -- BAD --> S["Repair or replace."]
      R -- OK --> T["Check air flow meter."]
      T -- BAD --> U["Repair or replace."]
      T -- OK --> V["② Check operation of oxygen sensors."]
      V -- OK --> W["System normal."]
      V -- BAD --> X["Check wiring between oxygen sensors and ECU connectors."]
      X -- BAD --> Y["Repair wiring."]
      X -- OK --> Z["Replace oxygen sensors."]
  
```

\* Rich malfunction only

California vehicles only

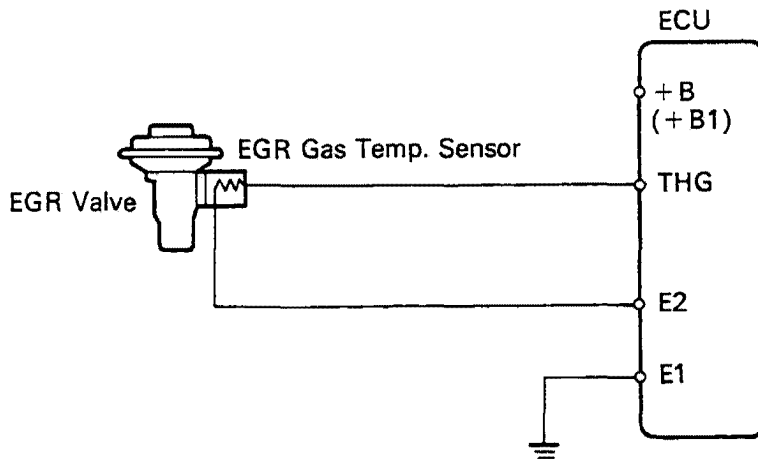

FI2680

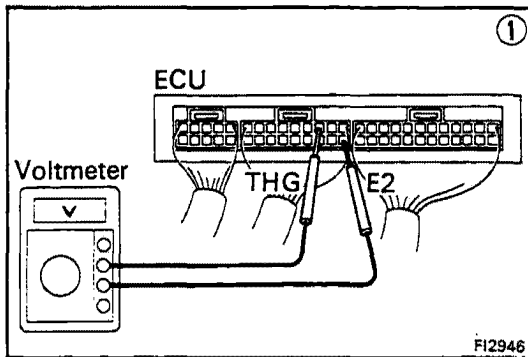

FI2946

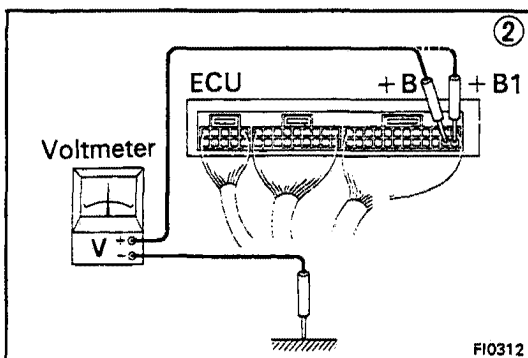

FI0312

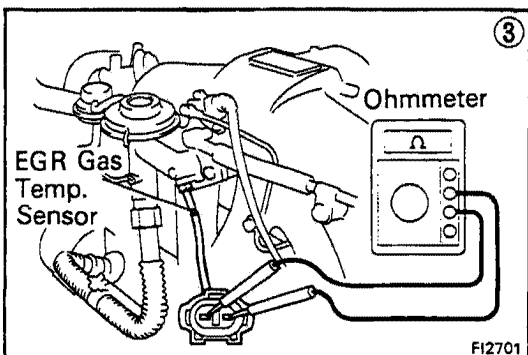

FI2701

① No voltage between ECU terminals THG and E2. (IG S/W ON)

② Check that there is voltage between ECU terminal + B (+ B1) and body ground. (IG S/W ON)

OK

NO

Refer to No. 1. (See page FI-30)

Check wiring between ECU terminal E1 and body ground.

OK

BAD

Refer or replace.

Check EGR system.

BAD

Repair or replace.

OK

③ Check EGR gas temp. sensor. (See page FI-79)

BAD

Replace EGR gas temp. sensor.

OK

Check wiring between ECU and EGR gas temp. sensor.

OK

Try another ECU.

BAD

Repair or replace.

# FUEL SYSTEM

## Fuel Pump

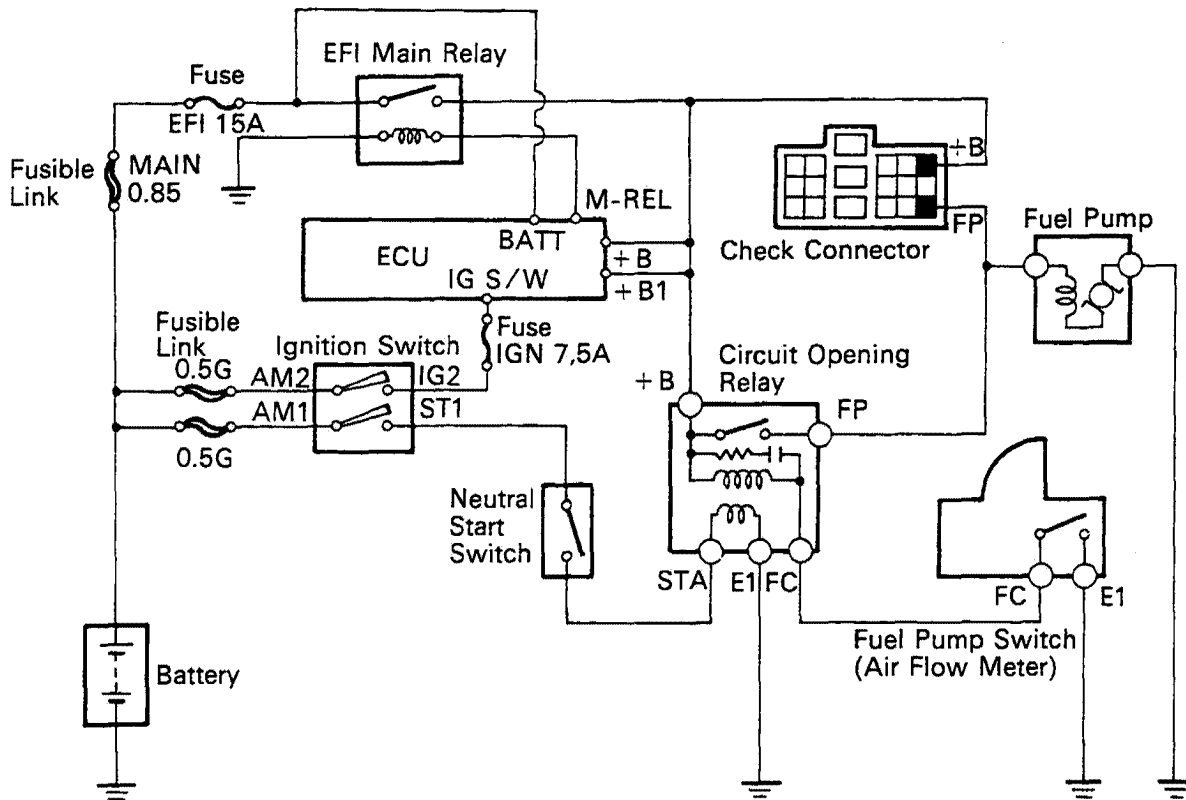
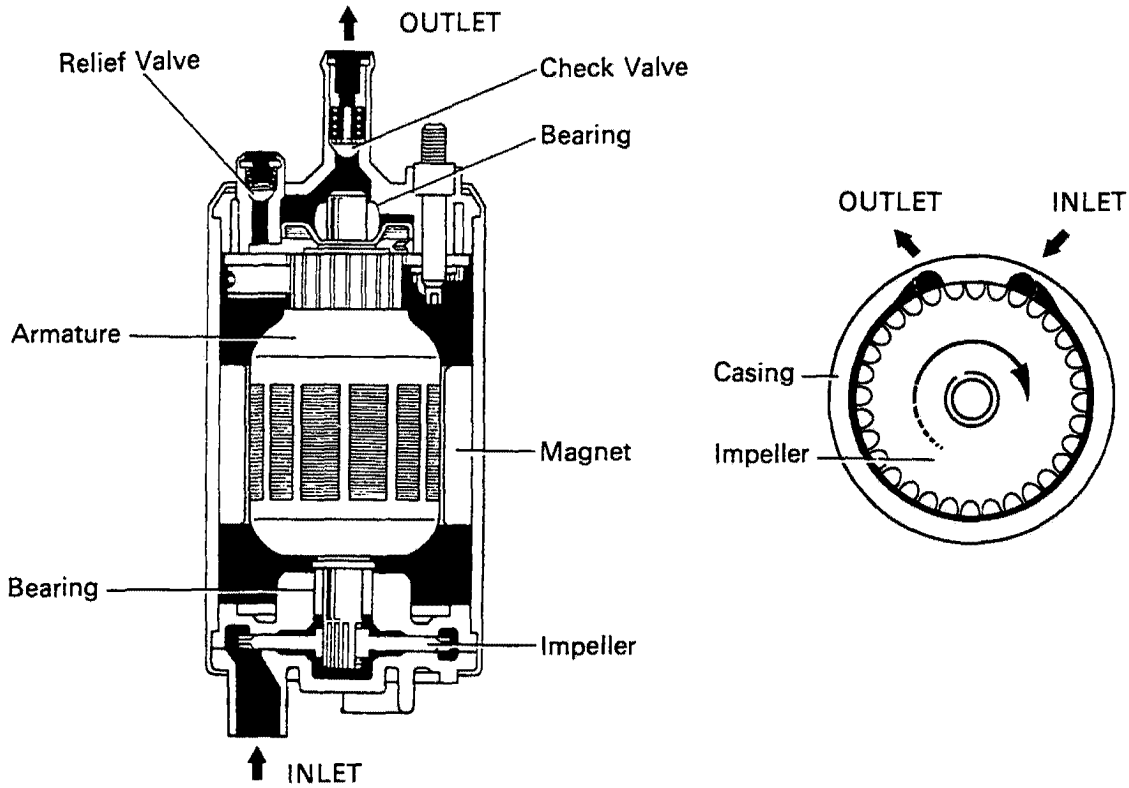

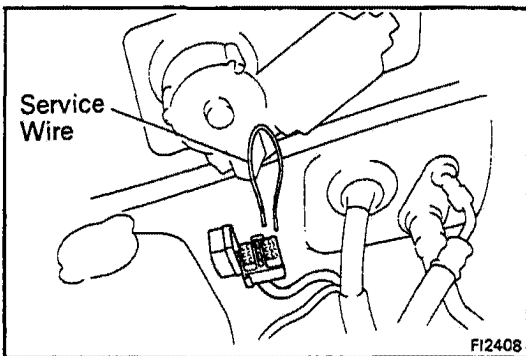
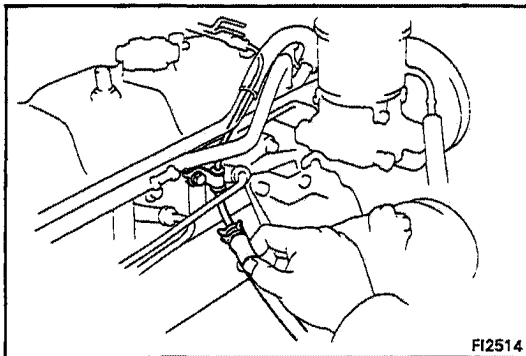
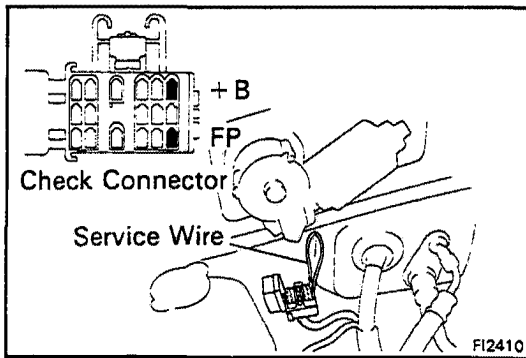

## ON-VEHICLE INSPECTION

### 1. INSPECT FUEL PUMP OPERATION

(a) Turn the ignition switch ON.

NOTE: Do not start the engine.

(b) Using a service wire, short terminals + B and FP of the check connector.

(c) Check that there is pressure in the fuel fuel return hose.

NOTE: At this time, you will hear fuel return noise.

(d) Remove the service wire.

(e) Turn the ignition switch OFF.

If there is no pressure, check the following parts:

- Fusible links
- Fuse (EFI 15A)
- EFI main relay
- Fuel pump
- Wiring connections

### 2. INSPECT FUEL PRESSURE

(a) Check the battery voltage above 11 volts.

(b) Disconnect the cable from the negative (-) terminal of the battery.

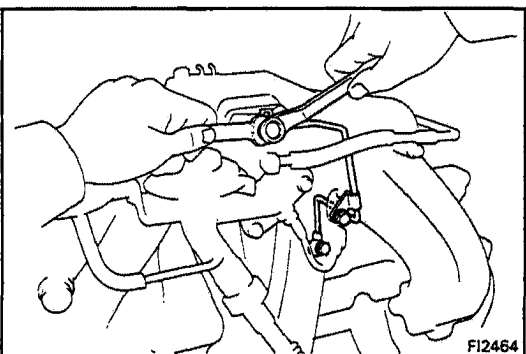

(c) Disconnect the cold start injector connector.

(d) Put a suitable container or shop towel under the cold start injector pipe.

(e) Remove the two union bolts, four gaskets, pipe clamp bolt and cold start injector pipe.

NOTE: Slowly loosen the union bolt.

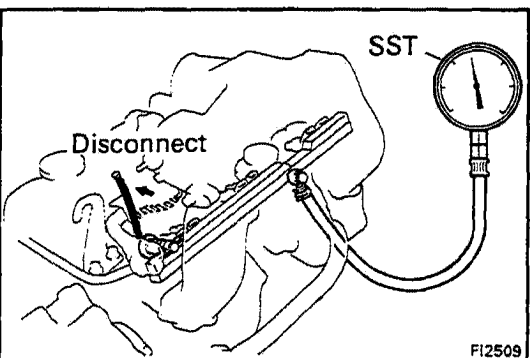
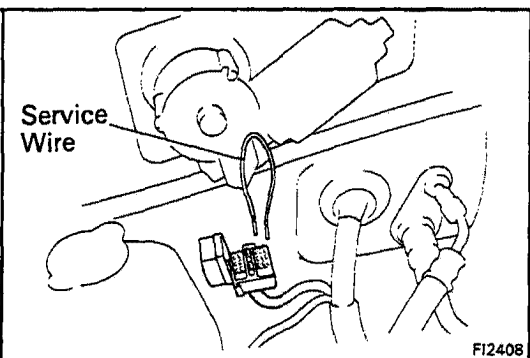
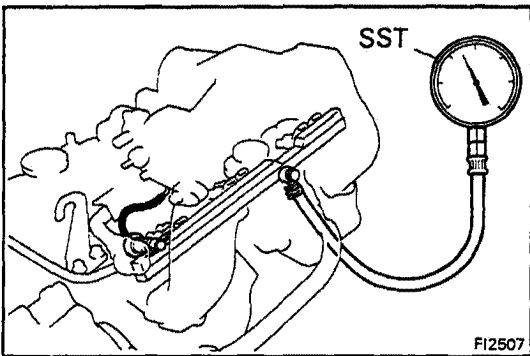
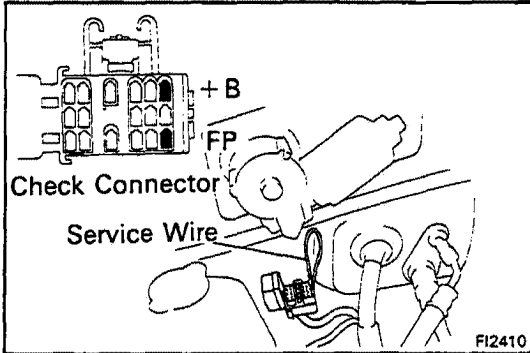
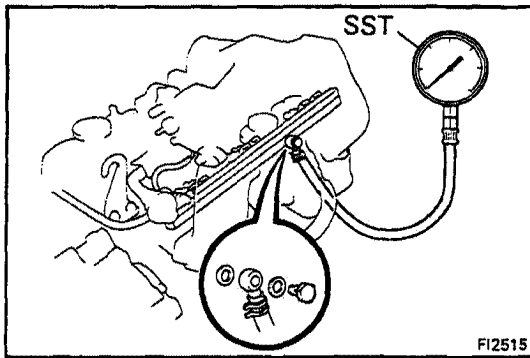

- (f) Install SST (pressure gauge) to the delivery pipe with new two gaskets and union bolt.

SST 09268-45012

**Torque: 180 kg-cm (13 ft-lb, 18 N·m)**

- (g) Wipe off any splattered gasoline.  
 (h) Reconnect the battery negative (-) cable.

- (i) Using a service wire, short terminals + B and FP of the check connector.

- (j) Turn the ignition switch ON.

- (k) Measure the fuel pressure.

**Fuel pressure: 2.6 – 3.2 kg/cm<sup>2</sup>  
 (37 – 46 psi, 255 – 314 kPa)**

If pressure is high, replace the fuel pressure regulator.

If pressure is low, check the following parts:

- Fuel hoses and connection
- Fuel pump
- Fuel filter
- Fuel pressure regulator

- (l) Remove the service wire.

- (m) Start the engine.

- (n) Disconnect the vacuum sensing hose from the fuel pressure regulator.

- (o) Measure the fuel pressure at idling.

**Fuel pressure: 2.6 – 3.2 kg/cm<sup>2</sup>  
 (37 – 46 psi, 255 – 314 kPa)**

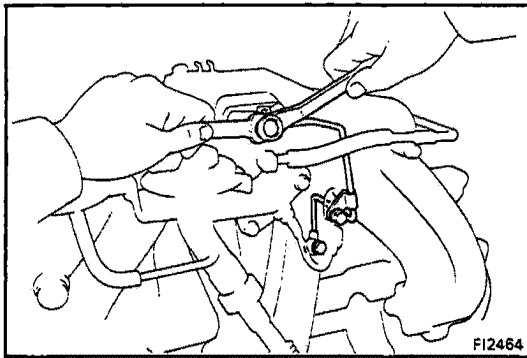
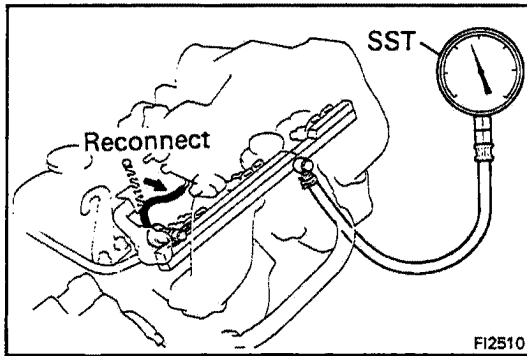

(p) Reconnect the vacuum sensing hose to the fuel pressure regulator.

(q) Measure the fuel pressure at idling.

**Fuel pressure: 2.3 – 2.6 kg/cm<sup>2</sup>  
(33 – 37 psi, 226 – 265 kPa)**

If pressure is not as specified, check the vacuum sensing hose and fuel pressure regulator.

(r) Stop the engine. Check that the fuel pressure remains 1.5 kg/cm<sup>2</sup> (21 psi, 147 kPa) or more for 5 minutes after the engine is turned off.

If pressure is not as specified, check the fuel pump, pressure regulator and/or injector.

(s) After checking fuel pressure, disconnect the battery negative (–) cable and carefully remove the SST to prevent gasoline from splashing.

SST 09268-45012

(t) Install the cold start injector pipe with new four gaskets, the union bolts and pipe clamp bolt.

**Torque:**

**Union bolt 180 kg-cm (13 ft-lb, 18 N·m)**

**Clamp bolt 120 kg-cm (9 ft-lb, 12 N·m)**

(u) Reconnect the cold start injector connector.

(v) Reconnect the cable to the negative (–) terminal of the battery.

(w) Check for fuel leakage.

## REMOVAL OF FUEL PUMP

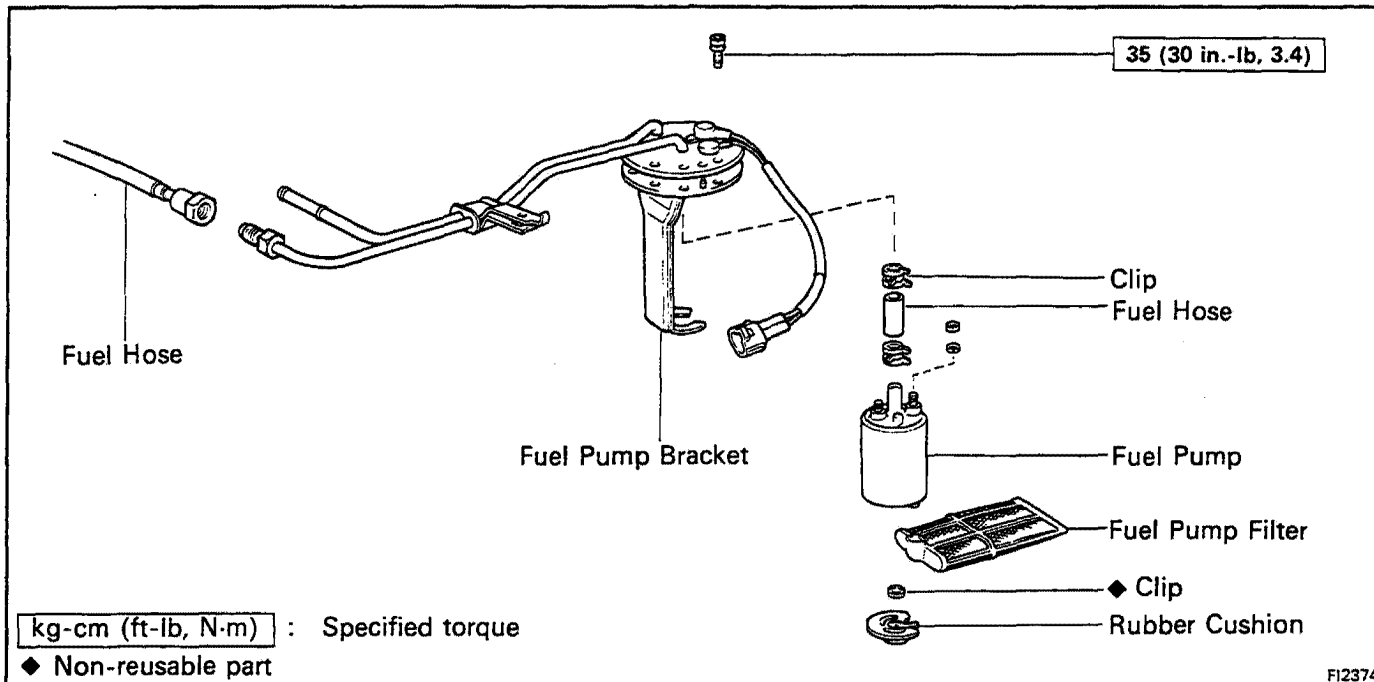

### 1. DISCONNECT CABLE FROM NEGATIVE TERMINAL OF BATTERY

### 2. DRAIN FUEL FROM FUEL TANK

**WARNING:** Do not smoke or work near an open flame when working on the fuel pump.

### 3. REMOVE FUEL TANK

### 4. REMOVE FUEL PUMP BRACKET FROM FUEL TANK

- Remove the screw of the wire clamp.
- Remove the screws, pull out the pump bracket.

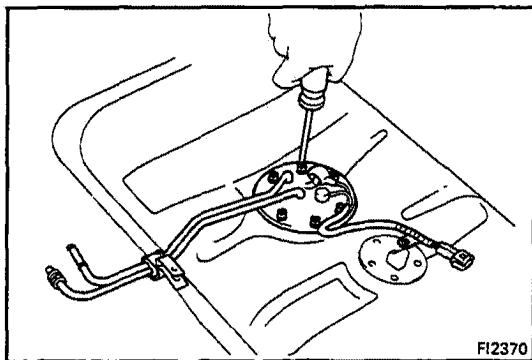

### 5. REMOVE FUEL PUMP FROM FUEL PUMP BRACKET

- Pull off the lower side of the fuel pump from the bracket.
- Remove the two nuts, and disconnect the wires from the fuel pump.
- Disconnect the fuel hose from the fuel hose.

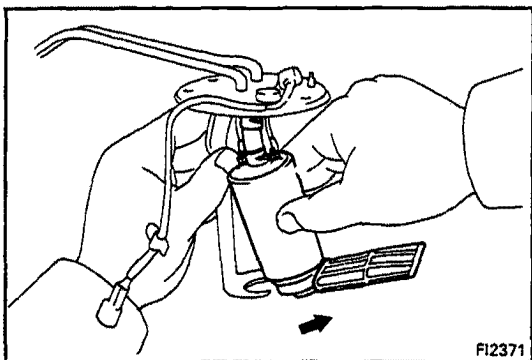

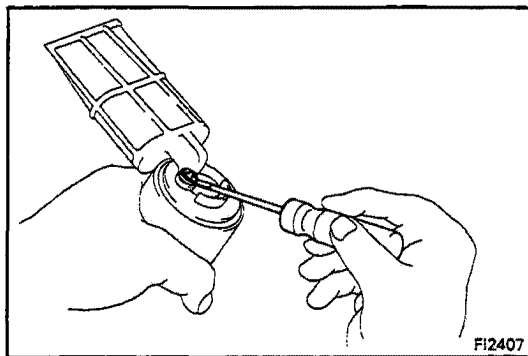

## 6. REMOVE FUEL PUMP FILTER FROM FUEL PUMP

- (a) Remove the rubber cushion.
- (b) Using a small screwdriver, remove the clip.
- (c) Pull out the pump filter.

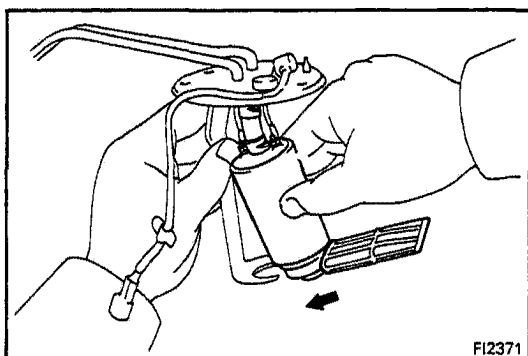

## INSTALLATION OF FUEL PUMP

(See page FI-50)

### 1. INSTALL FUEL PUMP FILTER TO FUEL PUMP

- (a) Install the pump filter with the clip.
- (b) Install the rubber cushion.

### 2. INSTALL FUEL PUMP TO FUEL PUMP BRACKET

- (a) Connect the fuel hose to the outlet port of the fuel pump.
- (b) Connect the wires to the fuel pump with the two nuts.
- (c) Push the lower side of the fuel pump, and install the fuel pump.

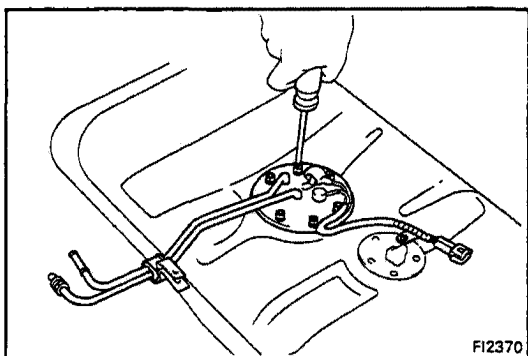

### 3. INSTALL FUEL PUMP BRACKET TO FUEL TANK

- (a) Install a new gasket and the pump bracket with the screws.

**Torque: 35 kg-cm (30 in.-lb, 3.4 N·m)**

- (b) Connect the wire clamp with the screw.

**Torque: 20 kg-cm (17 in.-lb, 2.0 N·m)**

### 4. INSTALL FUEL TANK

When installing the fuel tank, refer to FI-64 for the installation position of the cushion and the tightening torque.

### 5. CONNECT CABLE TO NEGATIVE TERMINAL OF BATTERY

## Cold Start Injector

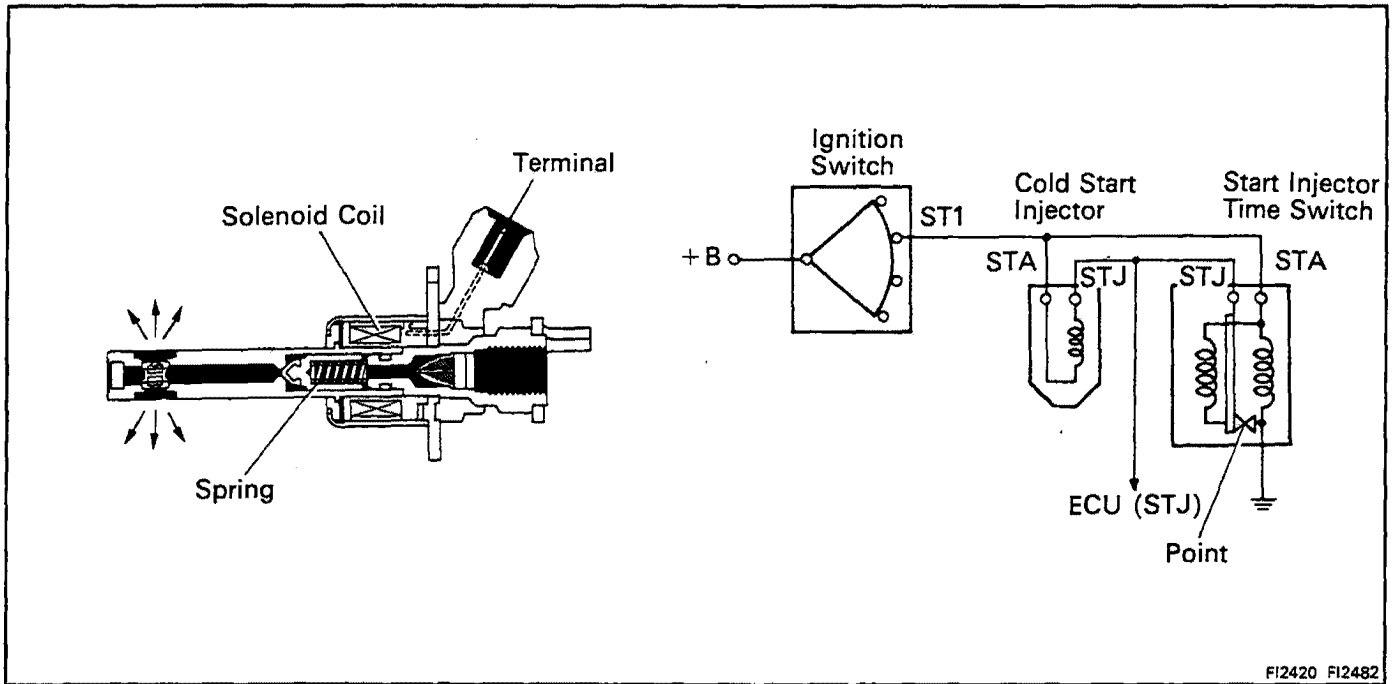

FI2420 FI2482

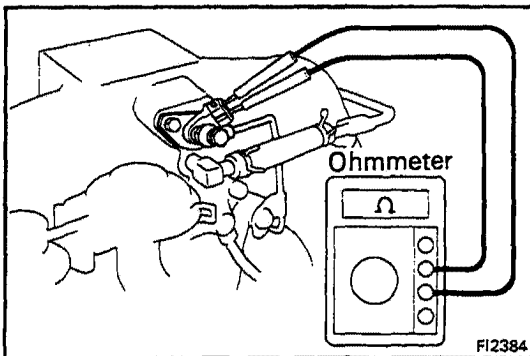

FI2384

### ON-VEHICLE INSPECTION

#### INSPECT RESISTANCE OF COLD START INJECTOR

- Disconnect the cold start injector connector.
- Using an ohmmeter, measure the resistance between the terminals.

**Resistance: 2 – 4  $\Omega$**

If the resistance is not as specified, replace the cold start injector.

- Reconnect the cold start injector connector.

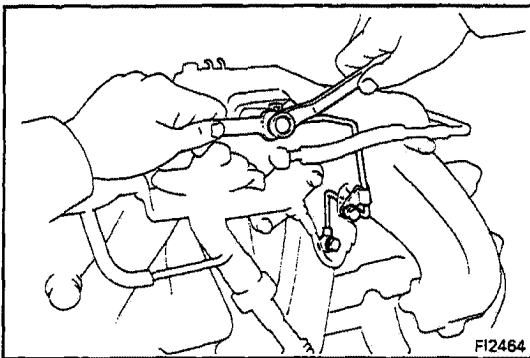

FI2464

### REMOVAL OF COLD START INJECTOR

- DISCONNECT CABLE FROM NEGATIVE TERMINAL OF BATTERY**
- DISCONNECT COLD START INJECTOR CONNECTOR**
- REMOVE COLD START INJECTOR PIPE**

(a) Put a suitable container or shop towel under the injector pipe.

(b) Remove the two union bolts, four gaskets, pipe clamp bolt and injector pipe.

NOTE: Slowly loosen the union bolts.

- REMOVE COLD START INJECTOR**

Remove the two bolts, cold start injector and gasket.

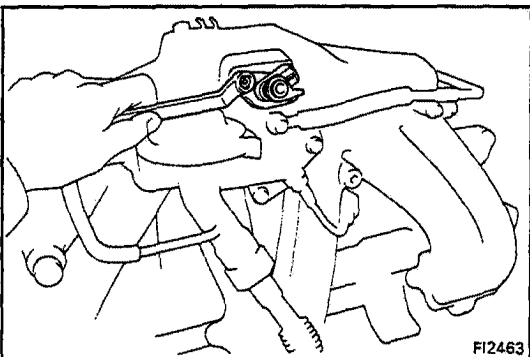

FI2463

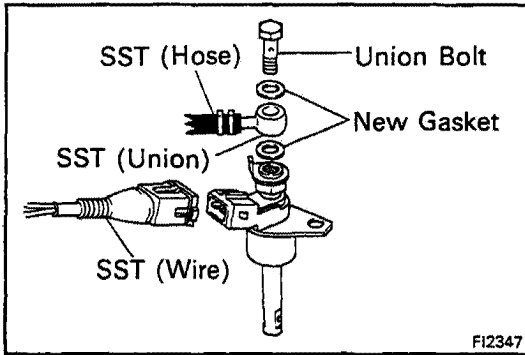

FI2347

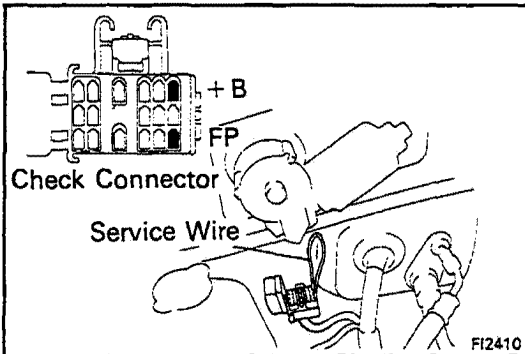

FI2410

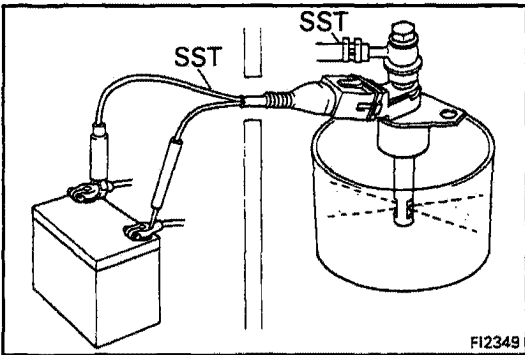

FI2349

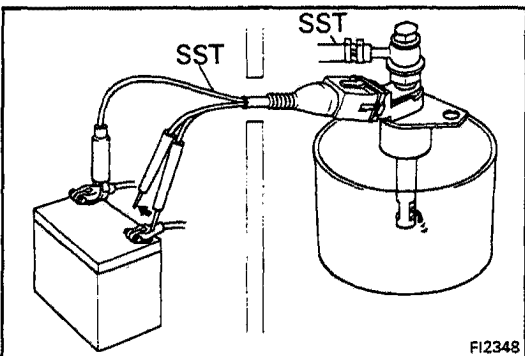

FI2348

## INSPECTION OF COLD START INJECTOR

### 1. INSPECT INJECTION OF COLD START INJECTOR

**WARNING:** Keep clear of sparks during the test.

- (a) Install SST (two unions) to the injector and delivery pipe with new gaskets and the union bolts.

SST 09268-41045

- (b) Connect SST (hose) to the unions.

SST 09268-41045

- (c) Connect SST (wire) to the injector.

SST 09842-30050

- (d) Put a container under the injector.

- (e) Reconnect the battery negative (-) cable.

- (f) Turn the ignition switch ON.

**NOTE:** Do not start the engine.

- (g) Using a service wire, short terminals + B and FP of the check connector.

- (h) Connect the test probes of the SST (wire) to the battery, and check that the fuel spray is as shown.

SST 09842-30050

**CAUTION:** Perform this check within the shortest possible time.

### 2. INSPECT LEAKAGE

- (a) In the condition above, disconnect the test probes of SST (wire) from the battery and check fuel leakage from the injector.

SST 09268-30050

Fuel drop: One drop or less per minute

- (b) Disconnect the battery negative (-) cable.

- (c) Remove SST and the service wire.

SST 09268-41045 and 09842-30050



## INSTALLATION OF COLD START INJECTOR

### 1. INSTALL COLD START INJECTOR

Install a new gasket and the injector with the two bolts.

**Torque: 50 kg-cm (43 in.-lb, 4.9 N·m)**

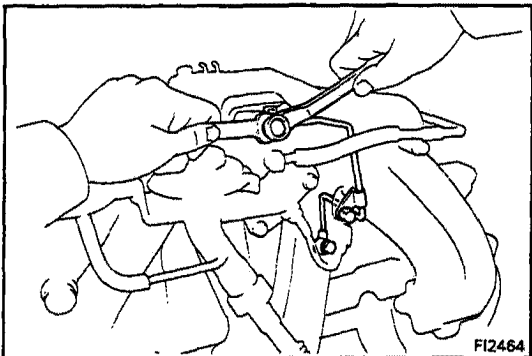

### 2. INSTALL COLD START INJECTOR PIPE

Install the cold injector pipe with new four gaskets, the two union bolts and pipe clamp bolt.

**Torque:**

**Union bolt 180 kg-cm (13 ft-lb, 18 N·m)**

**Clamp bolt 120 kg-cm (9 ft-lb, 12 N·m)**

### 3. CONNECT COLD START INJECTOR CONNECTOR

### 4. CONNECT CABLE TO NEGATIVE TERMINAL OF BATTERY

### 5. CHECK FOR FUEL LEAKAGE (See page FI-8)

## Fuel Pressure Regulator

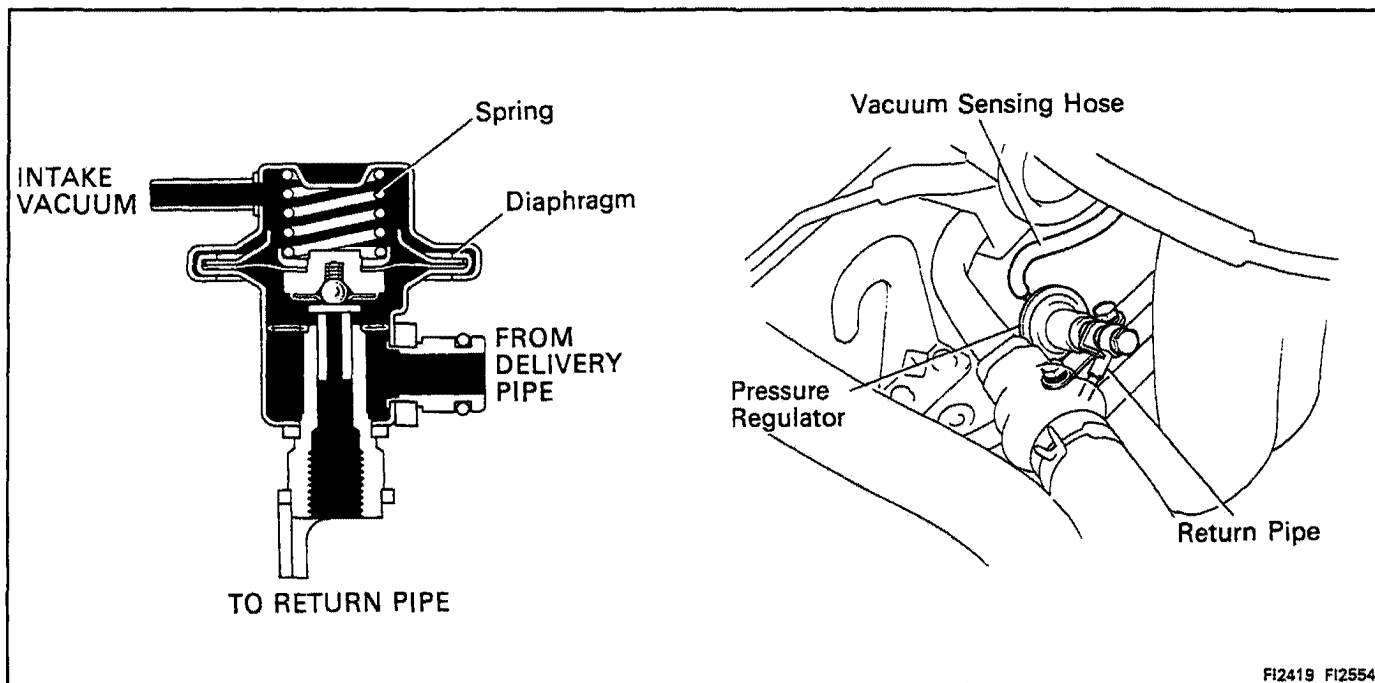

### ON-VEHICLE INSPECTION

INSPECT FUEL PRESSURE (See page FI-47)

### REMOVAL OF FUEL PRESSURE REGULATOR

#### 1. DISCONNECT VACUUM SENSING HOSE

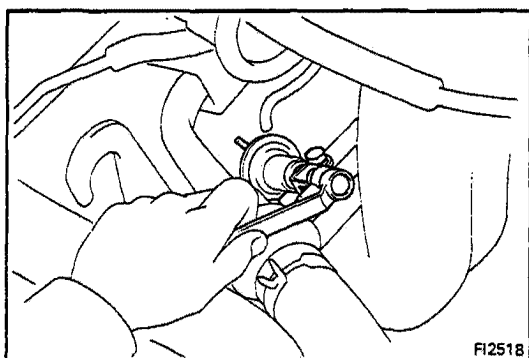

#### 2. DISCONNECT FUEL RETURN PIPE

- (a) Put a suitable container or shop towel under the pressure regulator.
- (b) Remove the union bolt and two gaskets, and disconnect the return pipe.

NOTE: Slowly loosen the union bolt.

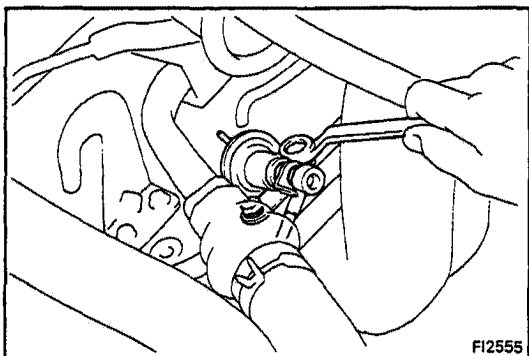

#### 3. REMOVE FUEL PRESSURE REGULATOR

Remove the two bolts, and pull out the pressure regulator.

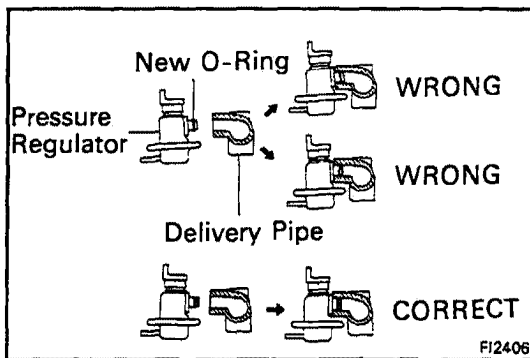

## INSTALLATION OF FUEL PRESSURE REGULATOR

### 1. INSTALL FUEL PRESSURE REGULATOR

- (a) Apply a light coat of gasoline to a new O-ring, and install it to the pressure regulator.

- (b) Install the pressure regulator with the two bolts.

**Torque: 50 kg-cm (43 in.-lb, 4.9 N·m)**

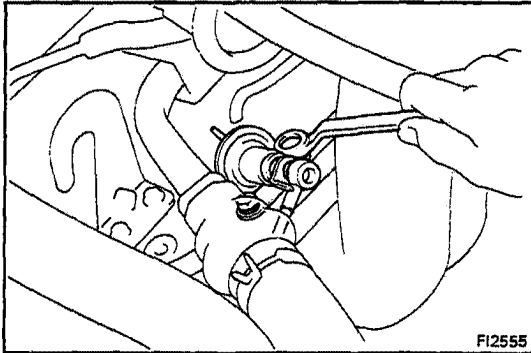

### 2. CONNECT FUEL RETURN PIPE

Install the return pipe with new two gaskets and the union bolt.

**Torque: 180 kg-cm (13 ft-lb, 18 N·m)**

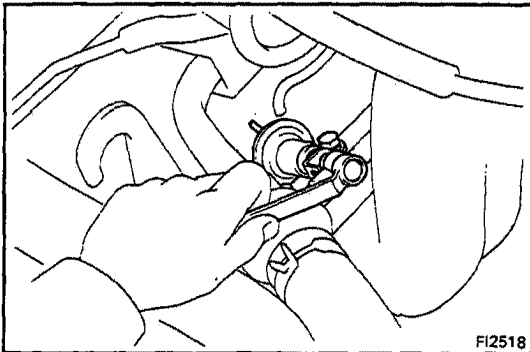

### 3. CONNECT VACUUM SENSING HOSE

### 4. CHECK FOR FUEL LEAKAGE (See page FI-8)

# Injectors

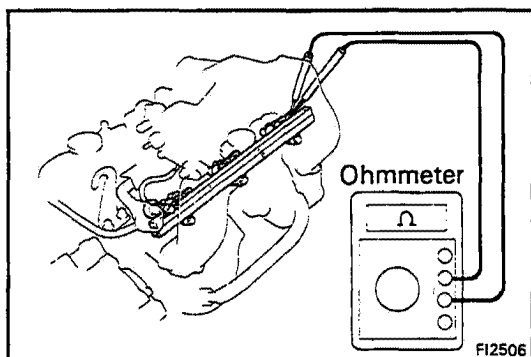
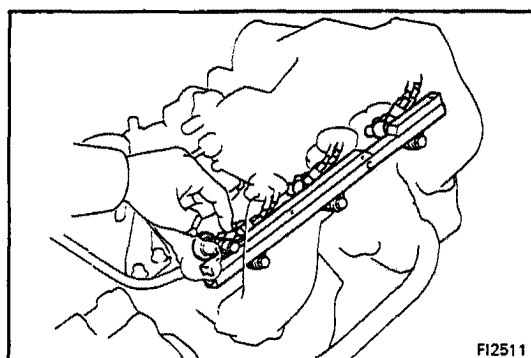
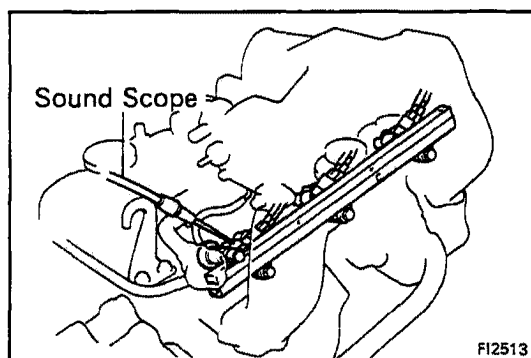
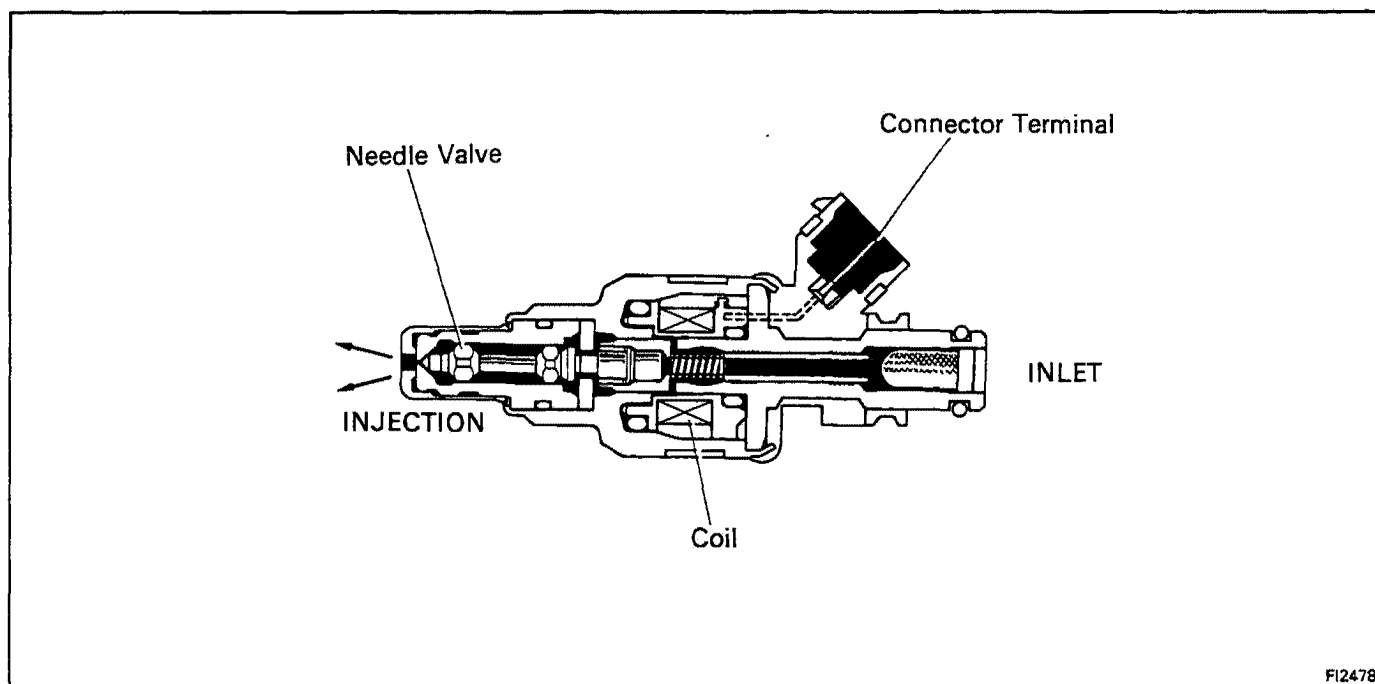

## ON-VEHICLE INSPECTION

### 1. INSPECT INJECTOR OPERATION

Check operation sound from each injector.

- (a) With the engine running or cranking, use a sound scope to check that there is normal operating noise in proportion to engine rpm.

- (b) If you have no sound scope, you can check the injector transmission operation with your finger.

If no sound or an unusual sound is heard, check the wiring connector, injector or injection signal from ECU.

### 2. INSPECT INJECTOR RESISTANCE

- (a) Disconnect the injector connector.
- (b) Using an ohmmeter, measure the resistance between the terminals.

**Resistance: Approx. 13.8  $\Omega$**

If the resistance is not as specified, replace the injector.

- (c) Reconnect the injector connector.

## REMOVAL OF INJECTOR

1. DISCONNECT CABLE FROM NEGATIVE TERMINAL OF BATTERY
2. DISCONNECT ACCELERATOR AND THROTTLE CABLES
3. REMOVE AIR INTAKE HOSE
4. DISCONNECT FOLLOWING HOSES:

(a) Emission control hoses

NOTE: Before disconnecting the emission control hoses, use tag to identify how they should be reconnected.

(b) Air hose from AI check valve

(c) Vacuum sensing hose

(d) PCV hose

(e) Vacuum hose for transfer

(f) Brake booster hose

5. DISCONNECT FOLLOWING CONNECTORS AND WIRE:

(a) ISC valve connector

(b) Throttle position sensor connector

(c) Oxygen sensor connector

(d) Manifold temperature sensor connector

(e) Cold start injector connector

(f) EGR gas sensor connector

(g) Ground strap

6. REMOVE AIR INTAKE CHAMBER

(a) Loosen the two union nuts, and remove the two clamp bolts and EGR pipe.

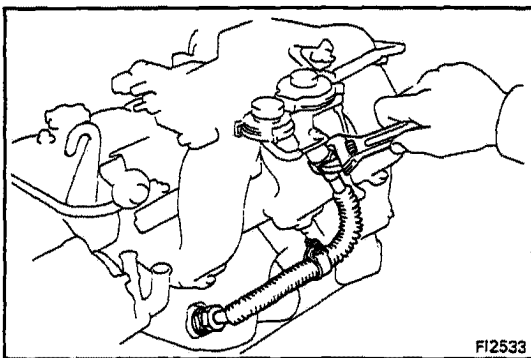

(b) Remove the two union bolts, four gaskets, clamp bolt and cold start injector pipe.

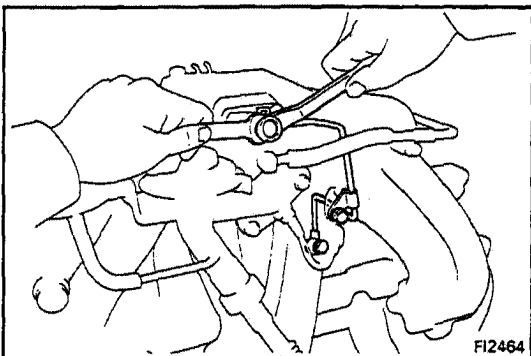

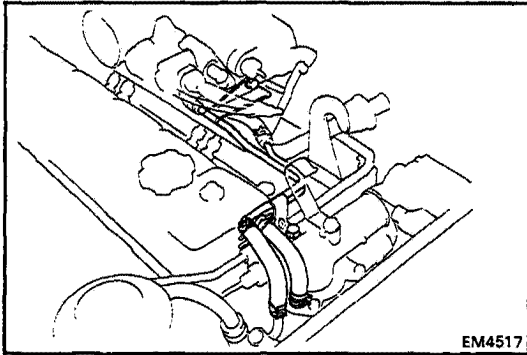

- (c) Disconnect the water hoses and remove the two bolts and water by-pass pipe.
- (d) Remove the four bolts and two intake chamber stays.

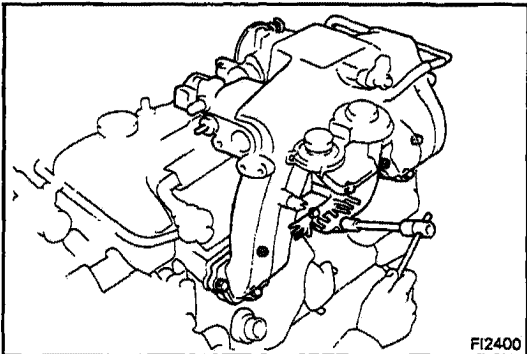

- (e) Remove the seven bolts, two nuts and air intake chamber.
- (f) Remove the bolt, manifold temperature sensor with stay and air intake chamber gasket.

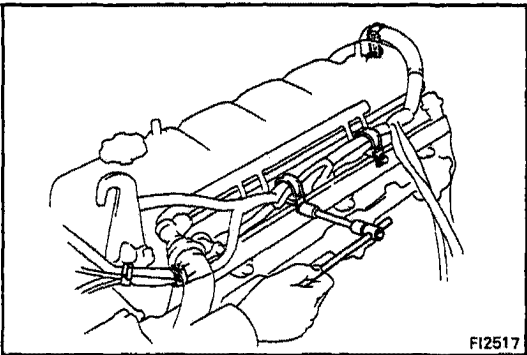

#### 7. DISCONNECT ENGINE WIRE HARNESS ON INTAKE MANIFOLD

- (a) Disconnect the following connectors:
  - (1) Cold start injector time switch connector
  - (2) Water temperature sensor connector
  - (3) Water temperature sender gauge connector
  - (4) Water temperature switch
  - (5) Six injector connectors
- (b) Remove the two clamps and three clamp bolts, and disconnect the engine wire harness.

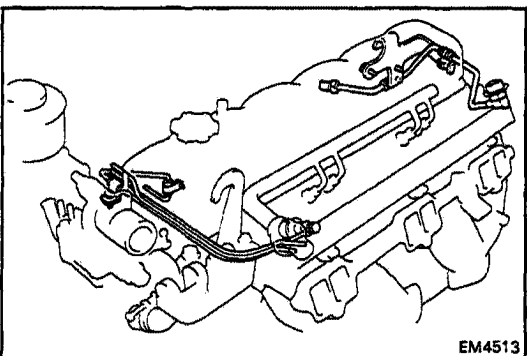

#### 8. REMOVE NO.1 FUEL PIPE AND NO.2 FUEL PIPE WITH ENGINE HANGER

- (a) Disconnect the fuel and vacuum hoses.
- (b) Remove the pulsation damper and two gaskets.
- (c) Remove the two bolts and No.2 fuel pipe with engine hanger.
- (d) Remove the union bolt and two gaskets from the pressure regulator.
- (e) Remove the two bolts and No.1 fuel pipe.

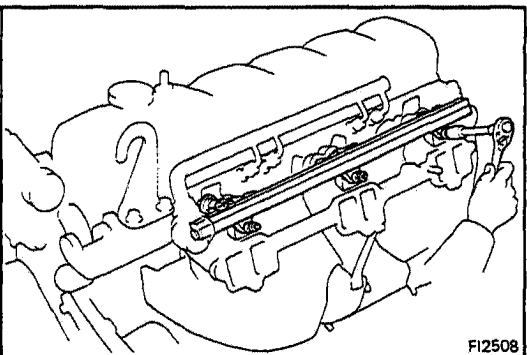

#### 9. REMOVE DELIVERY PIPE AND INJECTORS

- (a) Remove the three nuts, plate washers, spacers and delivery pipe together with the six injectors.

**CAUTION:** Be careful not to drop the injectors, when removing the delivery pipe.

- (b) Remove the six insulators, six spacers and three collars from the intake manifold.
- (c) Pull out the six injectors from the delivery pipe.

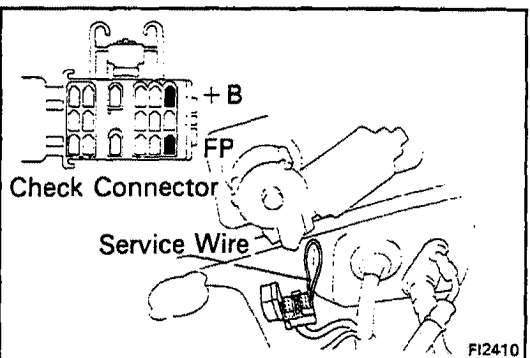
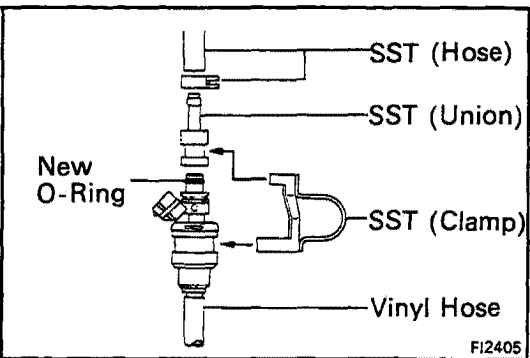
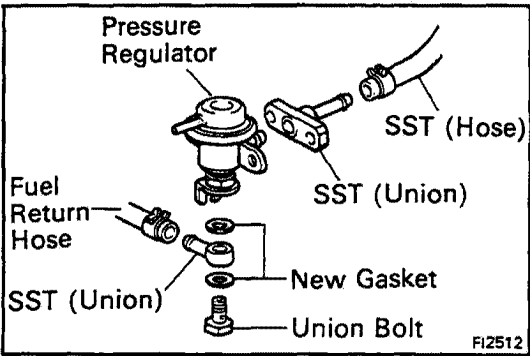
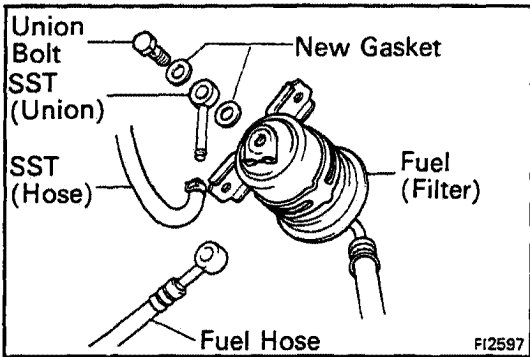
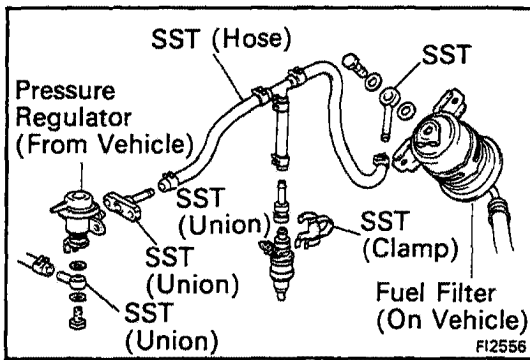

## INSPECTION OF INJECTORS

### 1. INSPECT INJECTOR INJECTION

**WARNING:** Keep clear of sparks during the test.

- (a) Disconnect the fuel hose from the fuel filter outlet.
- (b) Connect SST (union and hose) to the fuel filter outlet with new gaskets and the union bolt.

SST 09268-41045

**NOTE:** Use the vehicle's fuel filter.

- (c) Remove the pressure regulator. (See page FI-55)
- (d) Connect the fuel return hose and SST (hose) to the pressure regulator with SST (unions), new gaskets and union bolt.

SST 09268-41045

- (e) Connect SST (union and hose) to the injector, and hold the injector and union with SST (clamp).

SST 09268-41045

- (f) Put the injector into the graduated cylinder.

**NOTE:** Install the a suitable vinyl hose onto the injector to prevent gasoline from splashing out.

- (g) Reconnect the battery negative (-) cable.

- (h) Turn the ignition switch ON.

**NOTE:** Do not start the engine.

- (i) Using a service wire, short terminals + B and FP of the check connector.

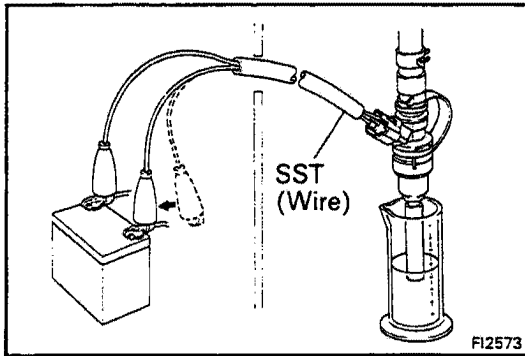

- (j) Connect SST (wire) to the injector and battery for 15 seconds, and measure the injection volume with a graduated cylinder. Test each injector two or three times.

SST 09842-30070

**Volume: 47 – 59 cc (2.9 – 3.6 cu in.) per 15 sec.**

**Difference between each injector:  
5 cc (0.3 cu in.) or less**

If the injection volume is not as specified, replace the injector.

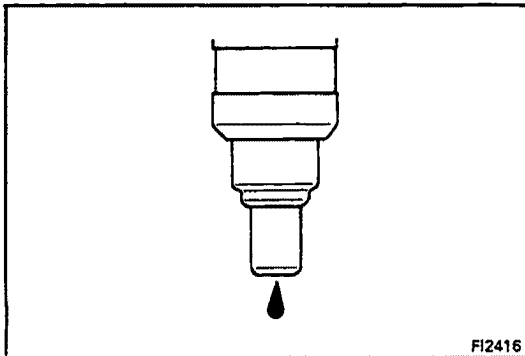

**2. INSPECT LEAKAGE**

- (a) In the condition above, disconnect the test probes of SST (wire) from the battery and check the fuel leakage from the injector.

SST 09842-30070

**Fuel drop: One drop or less per minute.**

- (b) Disconnect the battery negative (-) cable.
- (c) Remove SST and the service wire.

SST 09268-41045

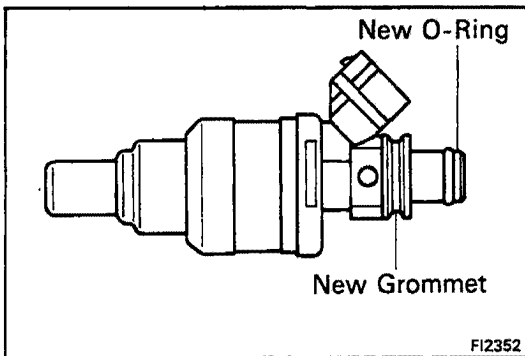

**INSTALLATION OF INJECTORS**

**1. INSTALL INJECTORS AND DELIVERY PIPE**

- (a) Install a new grommet to the injector.
- (b) Apply a light coat of gasoline to a new O-ring and install it to the injector.

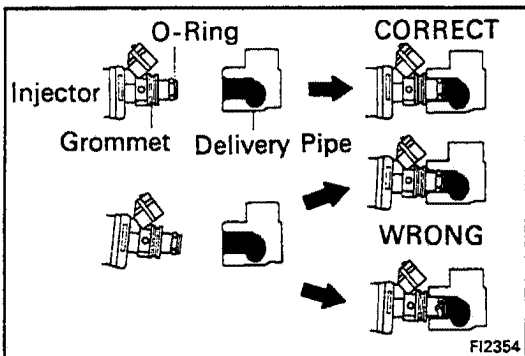

- (c) While turning the injector left and right, install it to the delivery pipe. Install the six injectors.

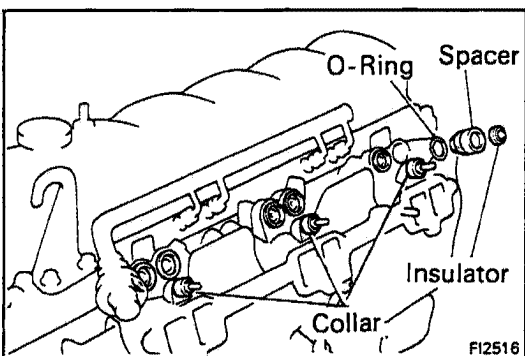

- (d) Install a new O-ring to the insulator.
- (e) Place the six insulators, six spacers and three collars in position on the intake manifold.

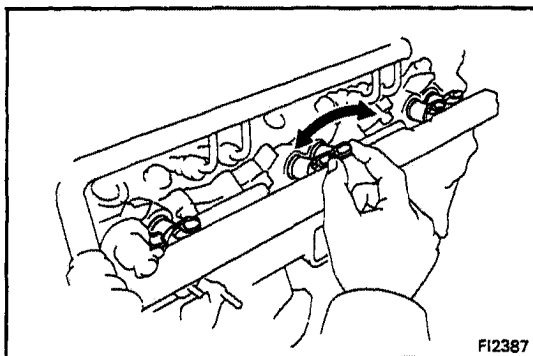

(f) Place the injectors together with the delivery pipe in position on the intake manifold.

(g) Check that the injectors rotate smoothly.

**NOTE:** If injectors do not rotate smoothly, the probable cause is incorrect installation of O-rings. Replace the O-rings.

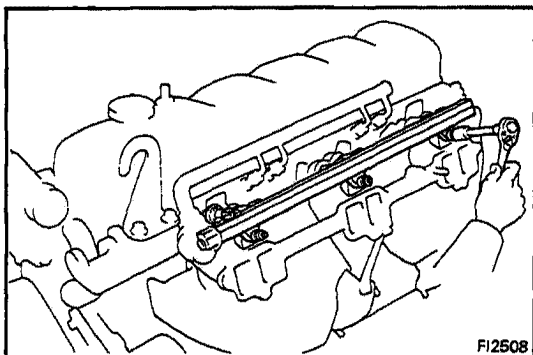

(h) Install the three spacers, plate washers and nuts. Torque the nuts.

**Torque: 120 kg-cm (9 ft-lb, 12 N·m)**

## 2. INSTALL NO.1 FUEL PIPE AND NO.2 FUEL PIPE WITH ENGINE HANGER

(a) Install the No.1 fuel pipe with the two bolts.

(b) Install the union bolt and new two gaskets to the pressure regulator.

**Torque: 195 kg-cm (14 ft-lb, 19 N·m)**

(c) Install the No.2 fuel pipe with engine hanger with the two bolts.

(d) Install the pulsation damper with the two new gasket.

**Torque: 300 kg-cm (22 ft-lb, 29 N·m)**

(e) Connect the two fuel hoses and vacuum hoses.

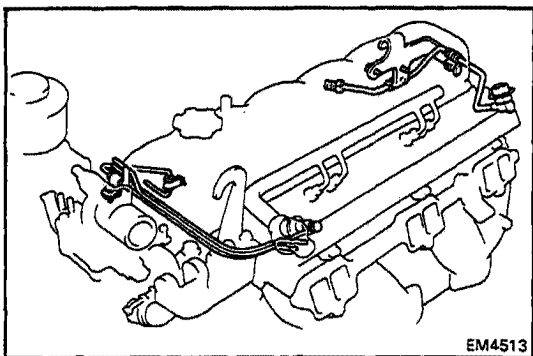

## 3. CONNECT ENGINE WIRE HARNESS ON INTAKE MANIFOLD

(a) Connect the following connectors:

(1) Cold start injector time switch connector

(2) Water temperature sensor connector

(3) Water temperature sender gauge connector

(4) Water temperature switch

(5) Six injector connectors

(b) Install the three clamp bolts and two clamp.

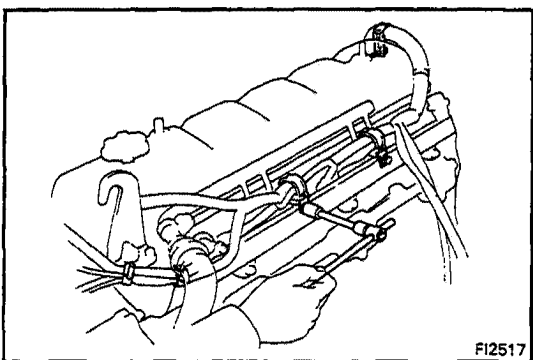

## 4. INSTALL AIR INTAKE CHAMBER

(a) Install a new gasket and air intake chamber with the seven bolts and two nuts.

**Torque: 250 kg-cm (18 ft-lb, 25 N·m)**

(b) Install the manifold temperature sensor with stay with the bolt.

**Torque: 120 kg-cm (9 ft-lb, 12 N·m)**

(c) Install the two intake chamber stays with the four bolts.

**Torque: 120 kg-cm (9 ft-lb, 12 N·m)**

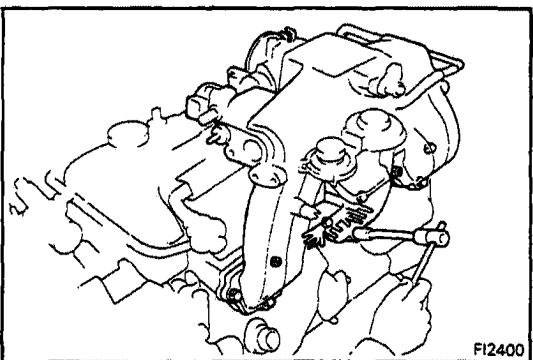

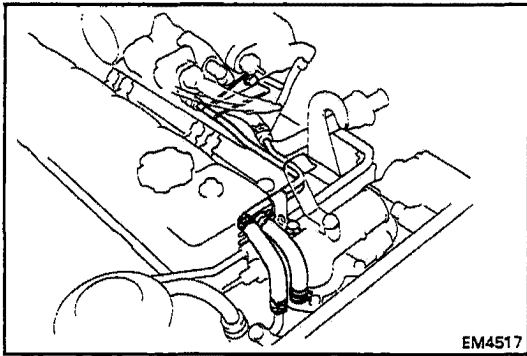

- (d) Install the water by-pass pipe with the two bolts and connect the water hoses.
- (e) Install the cold start injector pipe.  
(See page FI-54)

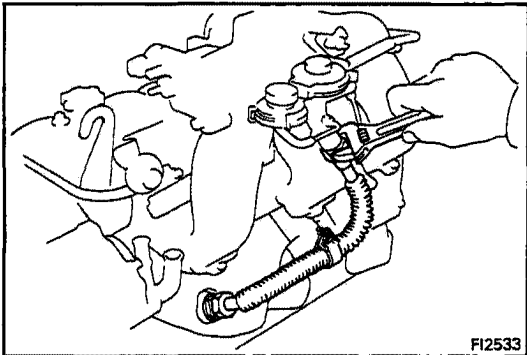

- (f) Install the EGR pipe with the two union nuts.  
**Torque: 800 kg-cm (58 ft-lb, 78 N·m)**
- (g) Install the two clamp mount bolts.

#### 5. CONNECT FOLLOWING CONNECTORS AND WIRE:

- (a) ISC valve connector
- (b) Throttle position sensor connector
- (c) Oxygen sensor connector
- (d) Manifold temperature sensor connector
- (e) Cold start injector connector
- (f) EGR gas sensor connector
- (g) Ground strap

#### 6. CONNECT FOLLOWING HOSES:

- (a) Emission control hoses
- (b) Air hose from AI check valve
- (c) Vacuum sensing hose
- (d) PCV hose
- (e) Vacuum hose for transfer
- (f) Brake booster hose

#### 7. INSTALL AIR INTAKE HOSE

#### 8. CONNECT ACCELERATOR AND THROTTLE CABLES, AND ADJUST THEM

#### 9. CONNECT CABLE TO NEGATIVE TERMINAL OF BATTERY

# Fuel Tank and Lines COMPONENTS

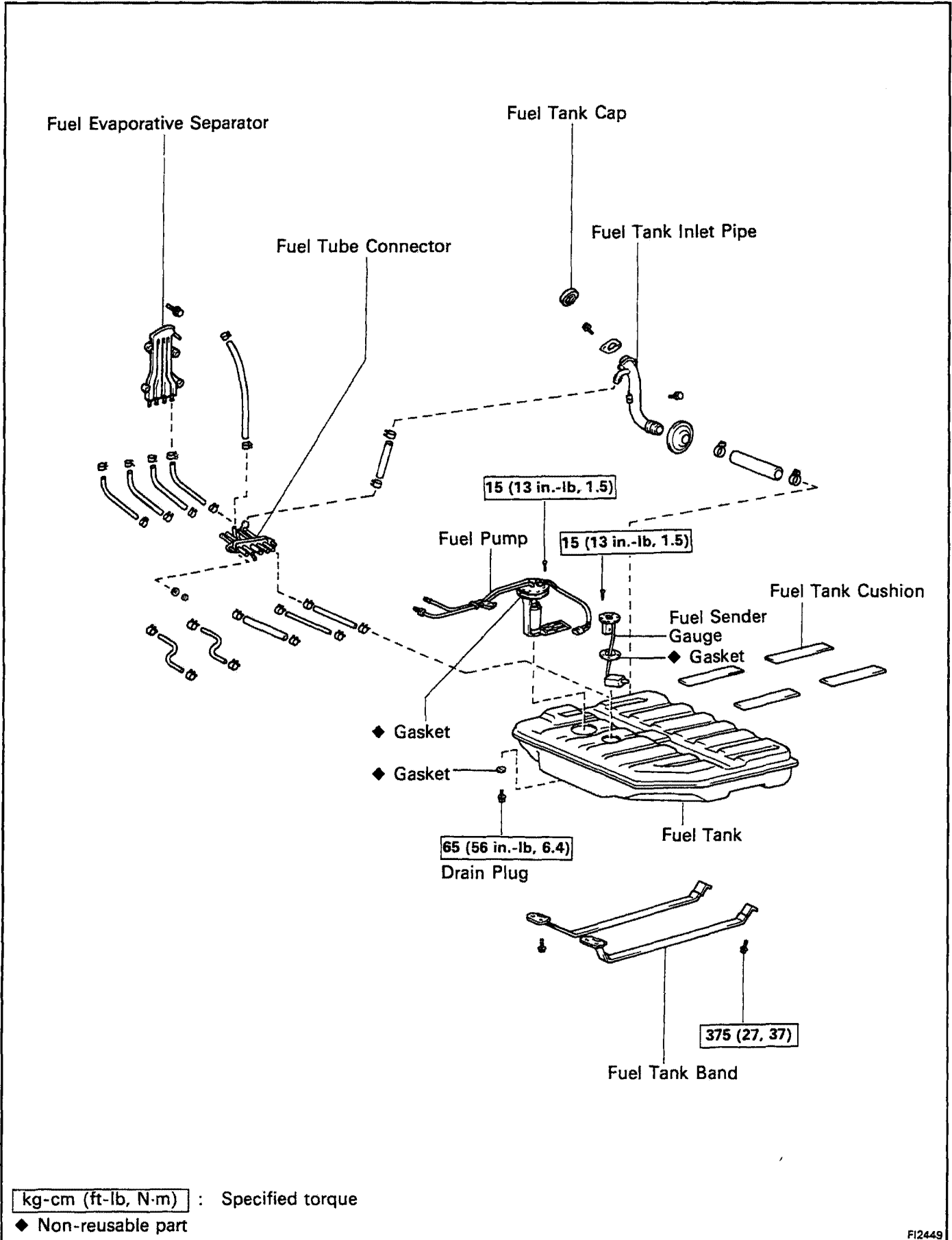

## PRECAUTIONS

1. Always use new gaskets when replacing the fuel tank or component parts.
2. Apply the proper torque to all parts tightened.

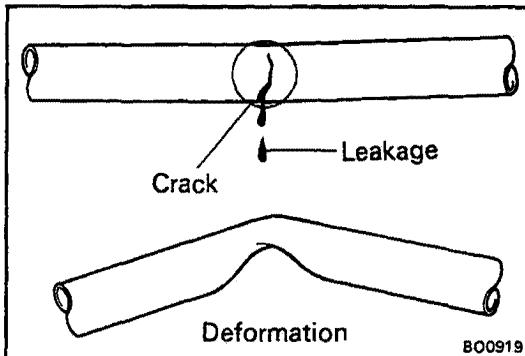

## INSPECT FUEL LINES AND CONNECTIONS

- (a) Check the fuel lines for cracks or leakage, and all connections for deformation.
- (b) Check the fuel tank vapor vent system hoses and connections for looseness, sharp bends or damage.
- (c) Check the fuel tank for deformation, cracks, fuel leakage or tank band looseness.
- (d) Check the filler neck for damage or fuel leakage.
- (e) Hose and tube connections are as shown in the illustration.

If a problem is found, repair or replace the parts as necessary.

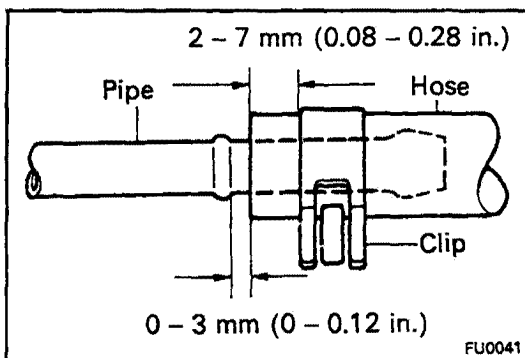
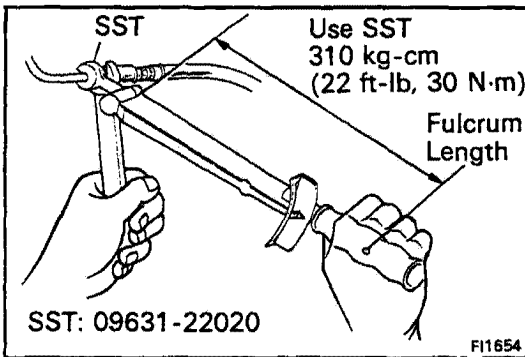

# AIR INDUCTION SYSTEM

## Air Flow Meter

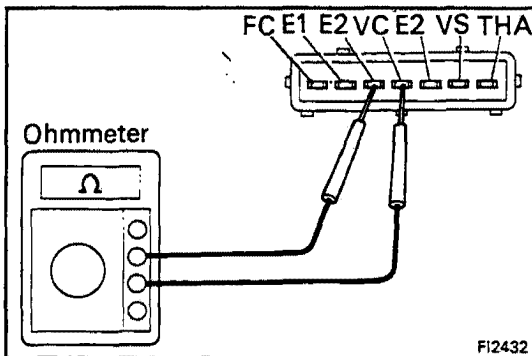
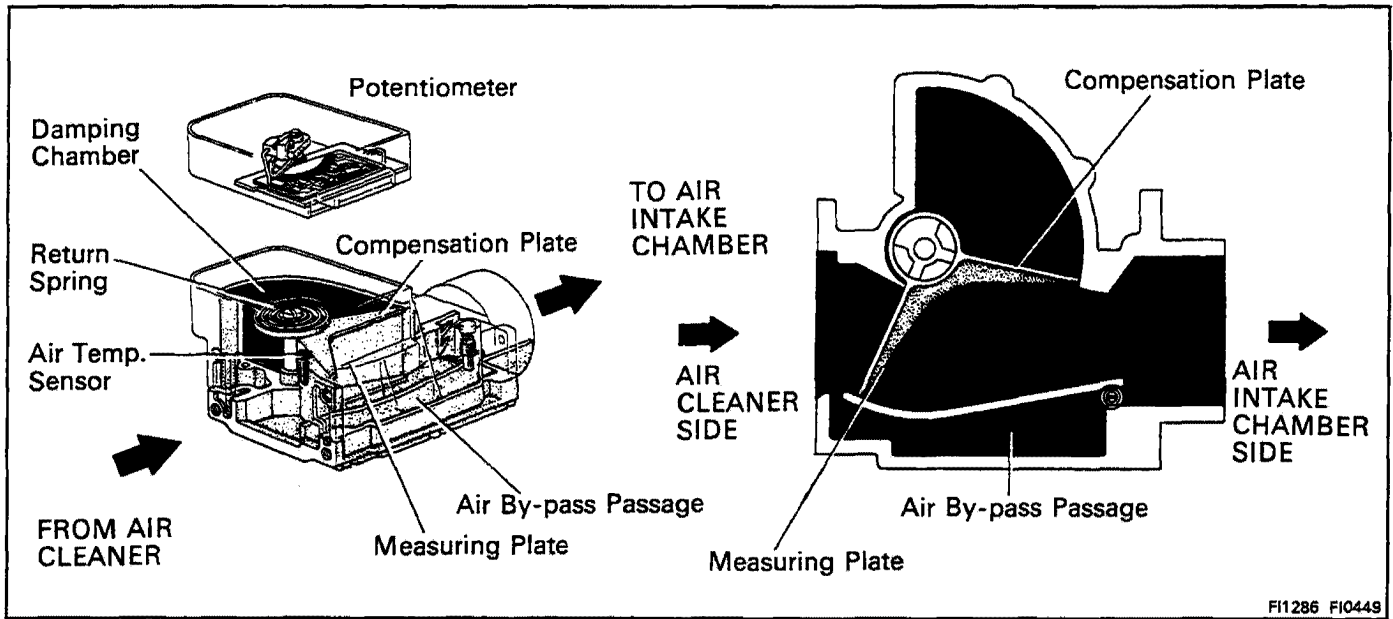

### ON-VEHICLE INSPECTION

#### INSPECT RESISTANCE OF AIR FLOW METER

- (a) Disconnect the air flow meter connector.
- (b) Using an ohmmeter, measure the resistance between each terminal.

Between terminals	Resistance	Temperature
E2 – VS	200 – 600 Ω	–
E2 – VC	200 – 400 Ω	–
E2 – THA	10 – 20 KΩ	–20°C (–4°F)
	4 – 7 KΩ	0°C (32°F)
	2 – 3 KΩ	20°C (68°F)
	0.9 – 1.3 KΩ	40°C (104°F)
E1 – FC	0.4 – 0.7 KΩ	60°C (140°F)
E1 – FC	Infinity	–

If the resistance is not as specified, replace the air flow meter.

- (c) Reconnect the air flow meter connector.

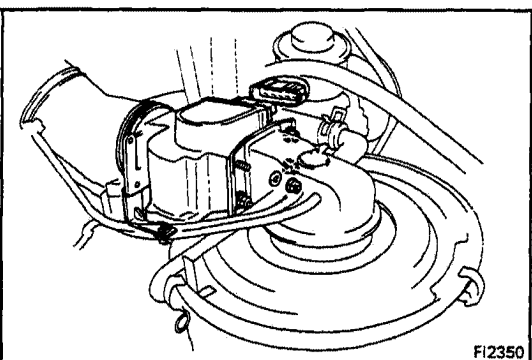
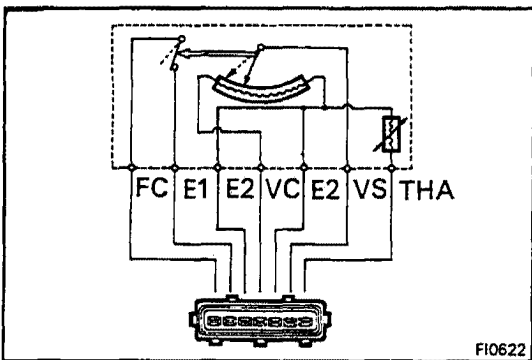

### REMOVAL OF AIR FLOW METER

1. DISCONNECT AIR FLOW METER CONNECTOR
2. DISCONNECT AIR CLEANER HOSE
3. REMOVE AIR FLOW METER

Remove the bolt, four nuts and air flow meter.

## INSPECTION OF AIR FLOW METER

### INSPECT RESISTANCE OF AIR FLOW METER

Using an ohmmeter, measure the resistance between each terminal by moving the measuring plate.

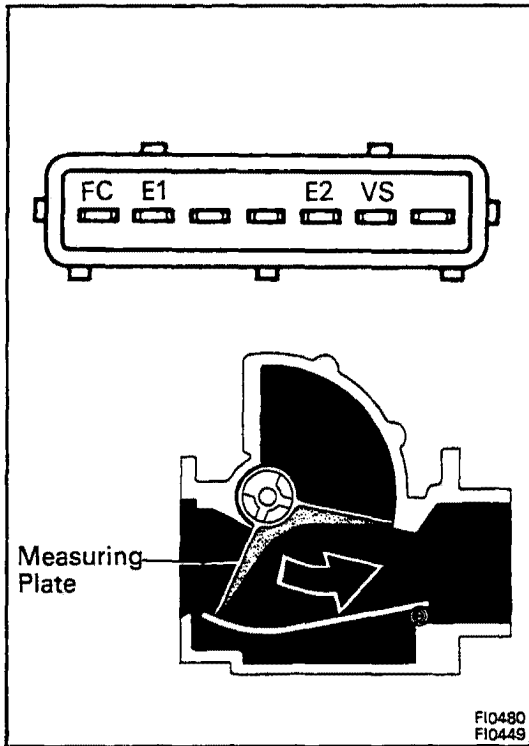

FI0480  
FI0449

Between Terminals	Resistance $\Omega$	Measuring plate opening
E1 – FC	Infinity	Fully closed
	Zero	Other than closed
E2 – VS	200 – 600	Fully closed
	20 – 1,200	Fully open

NOTE: Resistance between terminals E2 and VS will change in a wave pattern as the measuring plate slowly opens.

If the resistance is not as specified, replace the meter.

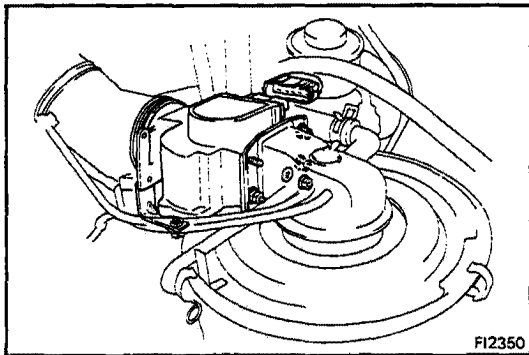

FI2350

## INSTALLATION OF AIR FLOW METER

1. INSTALL AIR FLOW METER
2. CONNECT AIR CLEANER HOSE
3. CONNECT AIR FLOW METER CONNECTOR

# Throttle Body

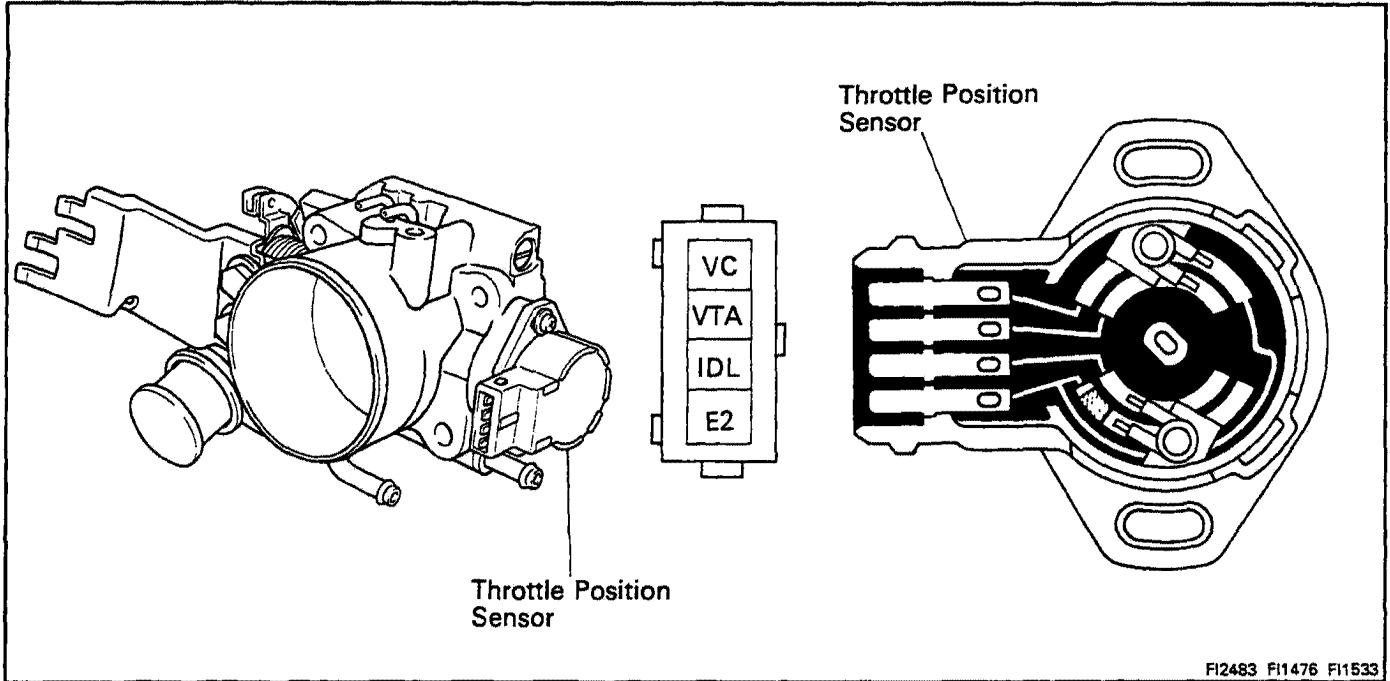

FI2483 FI1476 FI1533

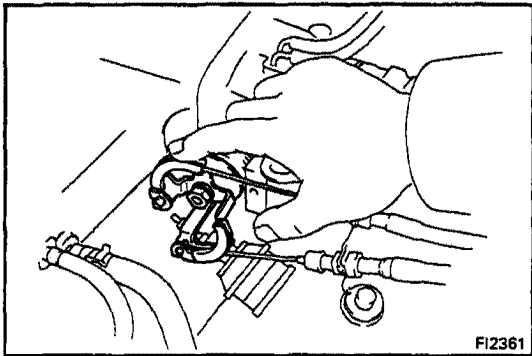

## ON-VEHICLE INSPECTION

### 1. INSPECT THROTTLE BODY

(a) Check that the throttle linkage moves smoothly.

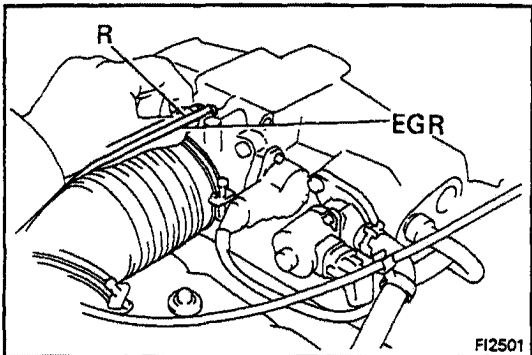

(b) Check the vacuum at each port.

- Start the engine.
- Check the vacuum with your finger.

Port No.	At idling	Other than idling
EGR	No vacuum	Vacuum
R	No Vacuum	Vacuum

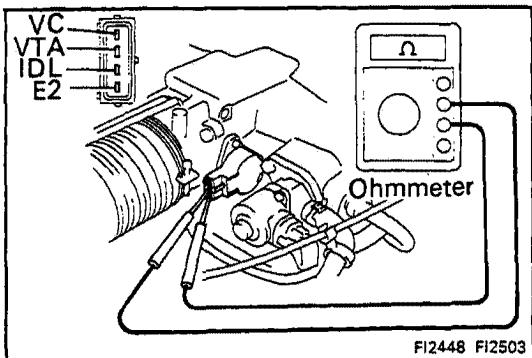

### 2. INSPECT THROTTLE POSITION SENSOR

- (a) Disconnect the sensor connector.
- (b) Insert a thickness gauge between the throttle stop screw and stop lever.
- (c) Using an ohmmeter, measure the resistance between each terminal.

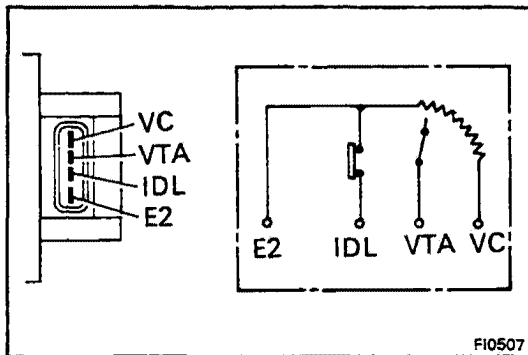

Clearance between lever and stop screw	Between terminals	Resistance
0 mm (0 in.)	VTA – E2	0.3 – 6.3 kΩ
0.77 mm (0.0303 in.)	IDL – E2	Less than 2.3 kΩ
1.09 mm (0.0429 in.)	IDL – E2	Infinity
Throttle valve fully opened position	VTA – E2	3.5 – 10.3 kΩ
—	VC – E2	4.25 – 8.25 kΩ

(d) Reconnect the sensor connector.

## REMOVAL OF THROTTLE BODY

1. DRAIN ENGINE COOLANT
2. DISCONNECT ACCELERATOR AND THROTTLE CABLES
3. DISCONNECT AIR CLEANER HOSE
4. DISCONNECT THROTTLE POSITION SENSOR CONNECTOR
5. DISCONNECT WATER HOSES
6. DISCONNECT VACUUM HOSES
7. REMOVE THROTTLE BODY

Remove the three bolts, nut, throttle body and gasket.

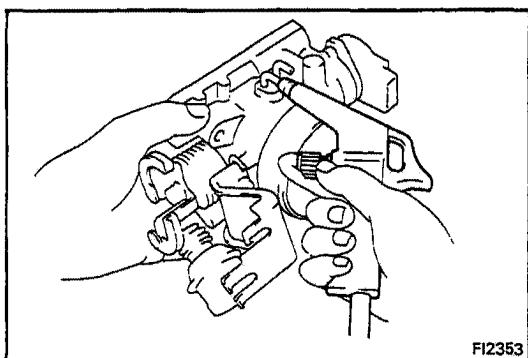
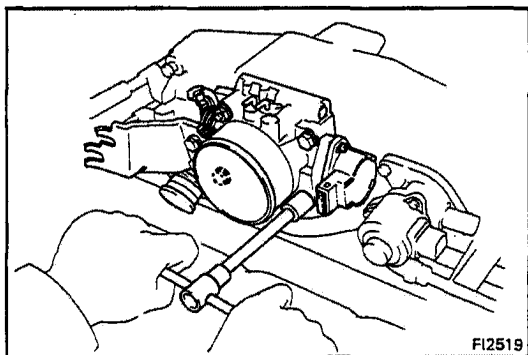
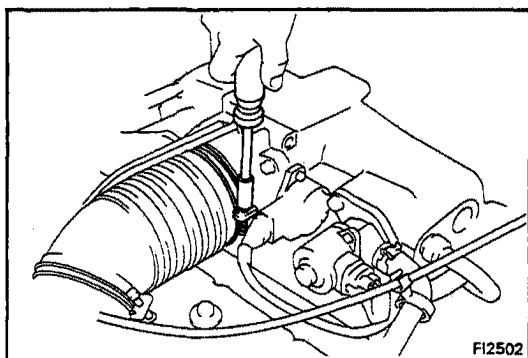

## INSPECTION OF THROTTLE BODY

1. CLEAN THROTTLE BODY
  - (a) Using a soft brush and carburetor cleaner, clean the cast parts.
  - (b) Using compressed air, clean all the passages and apertures.

**CAUTION:** To prevent deterioration, do not clean the throttle position sensor.

2. INSPECT THROTTLE VALVE

Check that there is no clearance between the throttle stop screw and throttle lever when the throttle valve is fully closed.

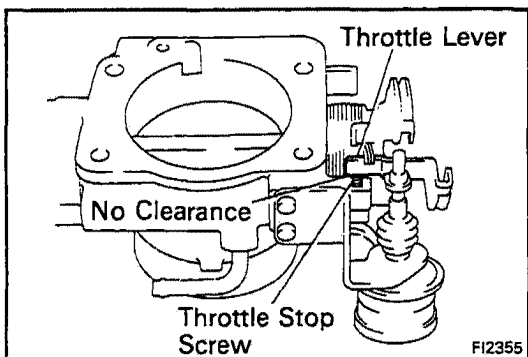

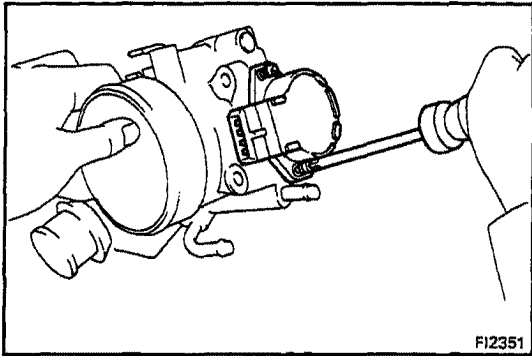

**3. INSPECT THROTTLE POSITION SENSOR**  
(See step 2 on page FI-68)

**4. IF NECESSARY, ADJUST THROTTLE POSITION SENSOR**

(a) Loosen the two set screws of the sensor.

(b) Insert a 0.93 mm (0.0366 in.) thickness gauge, between the throttle stop screw and stop lever.

(c) Connect the test probe of an ohmmeter to the terminals IDL and E2 of the sensor.

(d) Gradually turn the sensor clockwise until the ohmmeter deflects, and secure it with the two screws.

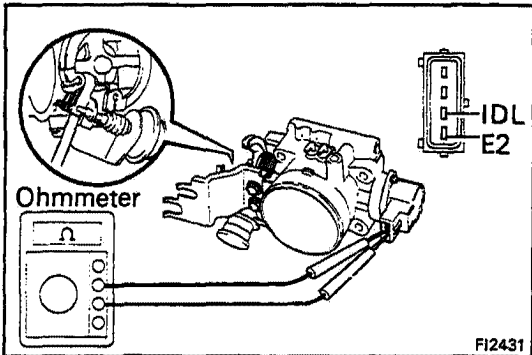

(e) Recheck the continuity between terminals IDL and E2.

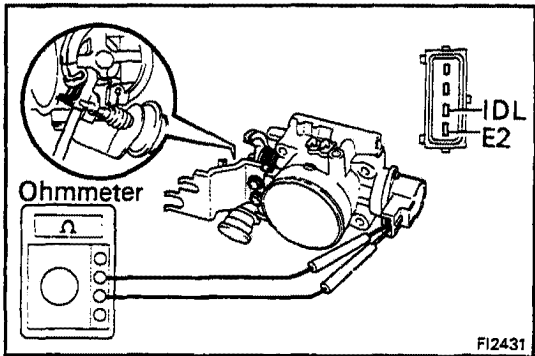

## INSTALLATION OF THROTTLE BODY

**1. INSTALL THROTTLE BODY**

Install a new gasket and the throttle body with the three bolts and nut.

Torque: 120 kg-cm (9 ft-lb, 12 N·m)

**2. CONNECT WATER HOSES**

**3. CONNECT VACUUM HOSES**

**4. CONNECT THROTTLE POSITION SENSOR CONNECTOR**

**5. CONNECT AIR CLEANER HOSE**

**6. CONNECT ACCELERATOR AND THROTTLE CABLES, AND ADJUST THEM**

**7. FILL WITH ENGINE COOLANT (See page CO-3)**

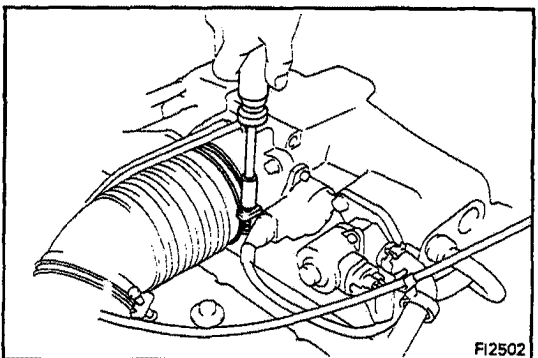
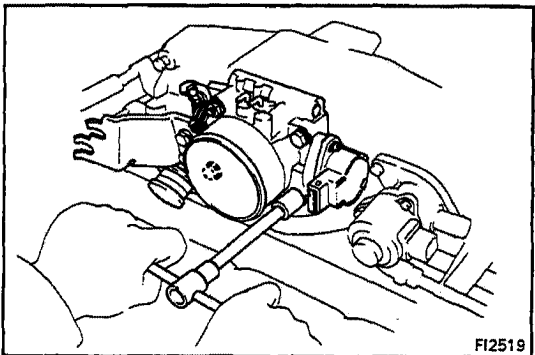

## Idle Speed Control (ISC) Valve

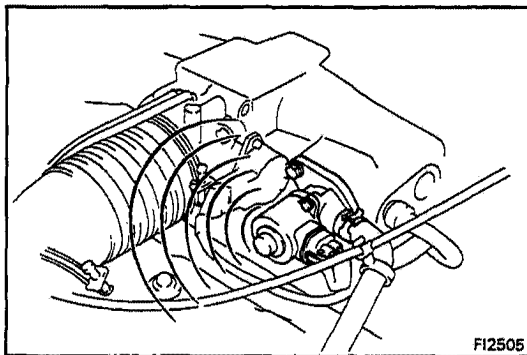
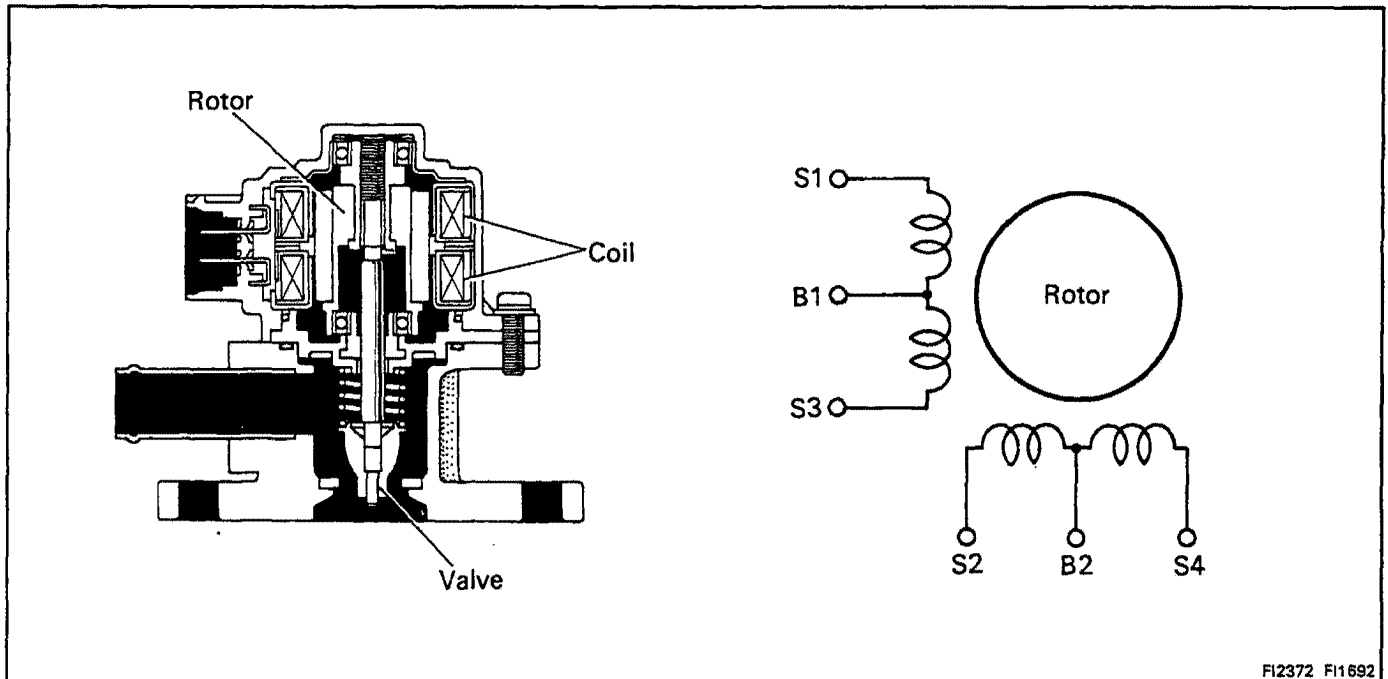

### ON-VEHICLE INSPECTION

#### CHECK FOR OPERATING SOUND FROM ISC VALVE

Check that there is a clicking sound immediately stopping the engine.

### REMOVAL OF ISC VALVE

1. DRAIN ENGINE COOLANT
2. DISCONNECT ISC VALVE CONNECTOR
3. DISCONNECT AIR AND TWO WATER BY-PASS HOSES
4. REMOVE ISC VALVE  
Remove the two bolts, ISC valve and gasket.

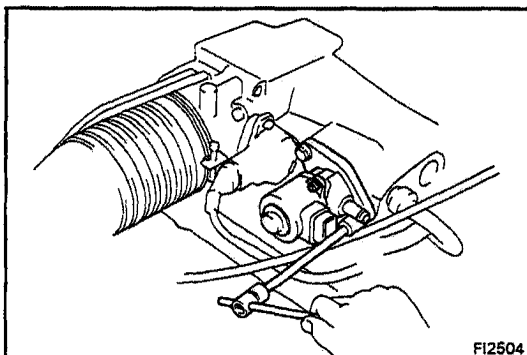

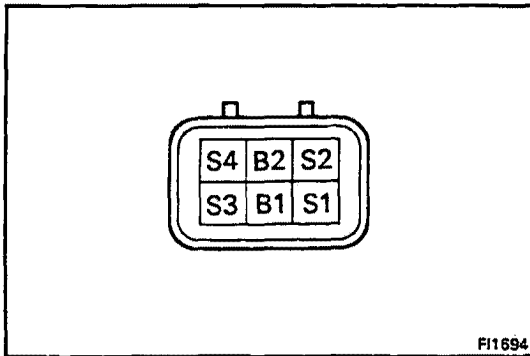

FI1694

## INSPECTION OF ISC VALVE

### 1. INSPECT ISC VALVE RESISTANCE

Using an ohmmeter, measure the resistance between terminal B1 – S1 or S3, and B2 – S2 or S4.

**Resistance:** B1 – S1 or S3 10 – 30 Ω  
B2 – S2 or S4 10 – 30 Ω

If resistance is not as specified, replace the ISC valve.

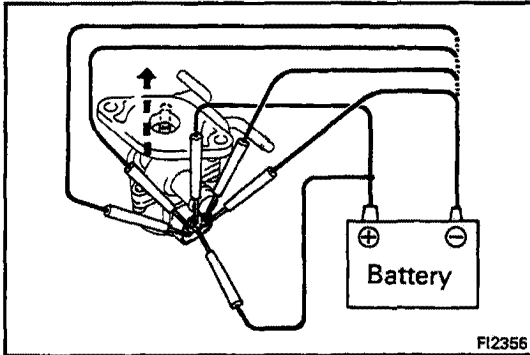

FI2356

### 2. INSPECT ISC VALVE OPERATION

(a) Apply battery voltage to terminals B1 and B2, and while repeatedly grounding S1 – S2 – S3 – S4 – S1 in sequence, check that the valve moves toward the closed position.

(b) Apply battery voltage to terminals B1 and B2, and while repeatedly grounding S4 – S3 – S2 – S1 – S4 in sequence, check that the valve moves toward the closed position.

If operation is not as specified, replace the ISC valve.

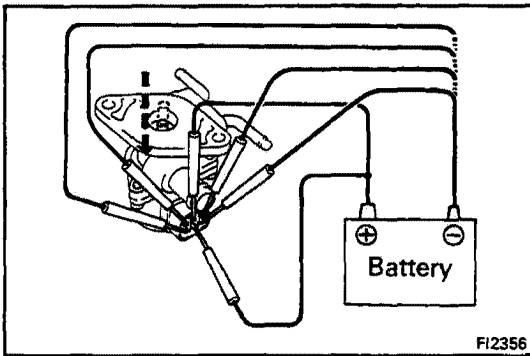

FI2356

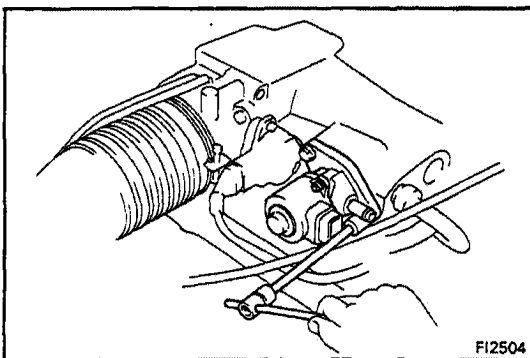

FI2504

## INSTALLATION OF ISC VALVE

### 1. INSTALL ISC VALVE

Install a new gasket and ISC valve with the two bolts.

**Torque:** 120 kg-cm (9 ft-lb, 12 N·m)

### 2. CONNECT TWO WATER BY-PASS AND AIR HOSES

### 3. CONNECT ISC VALVE CONNECTOR

### 4. FILL WITH ENGINE COOLANT (See page CO-3)

# ELECTRONIC CONTROL SYSTEM

## Location of Electronic Control Parts

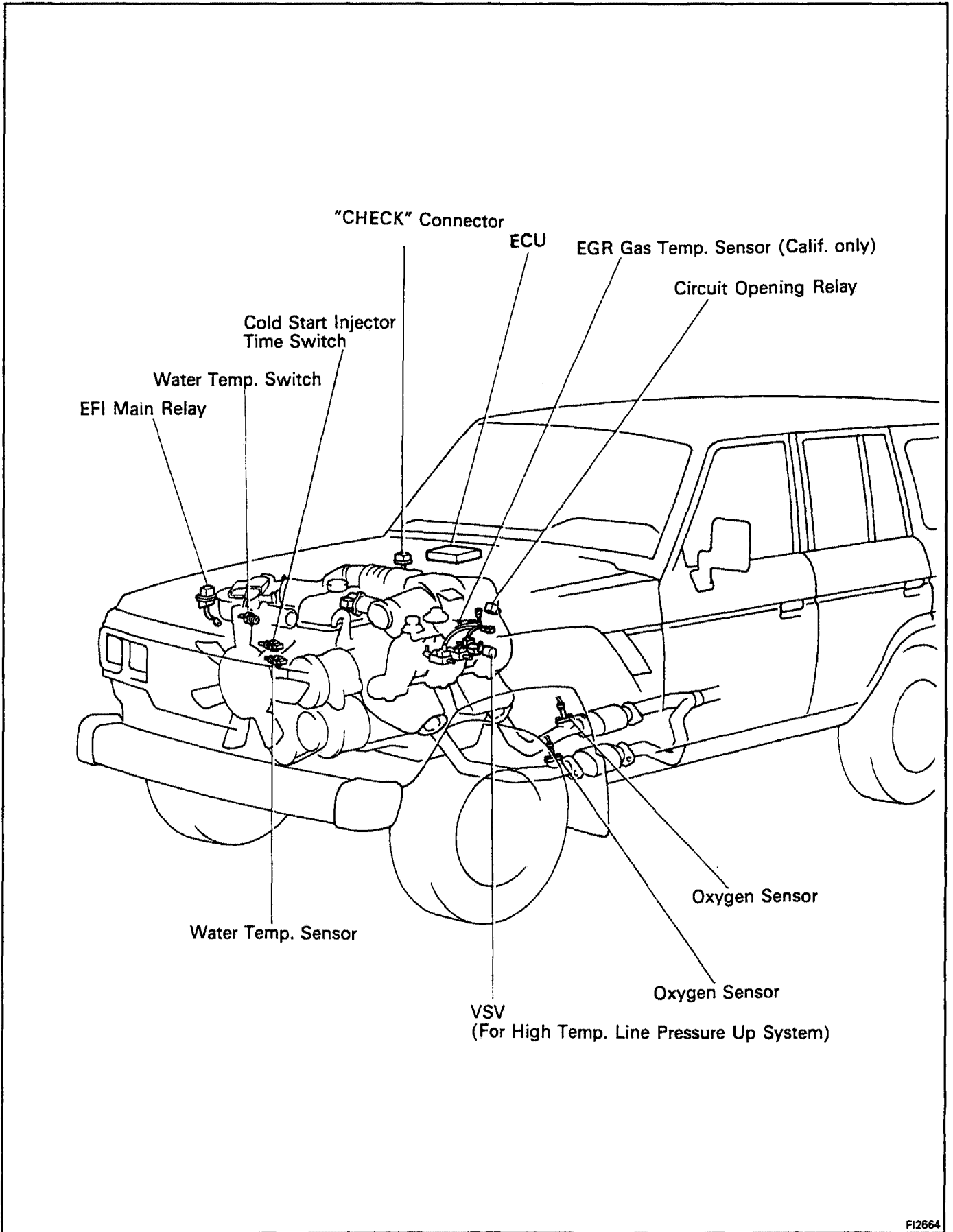

# EFI Main Relay

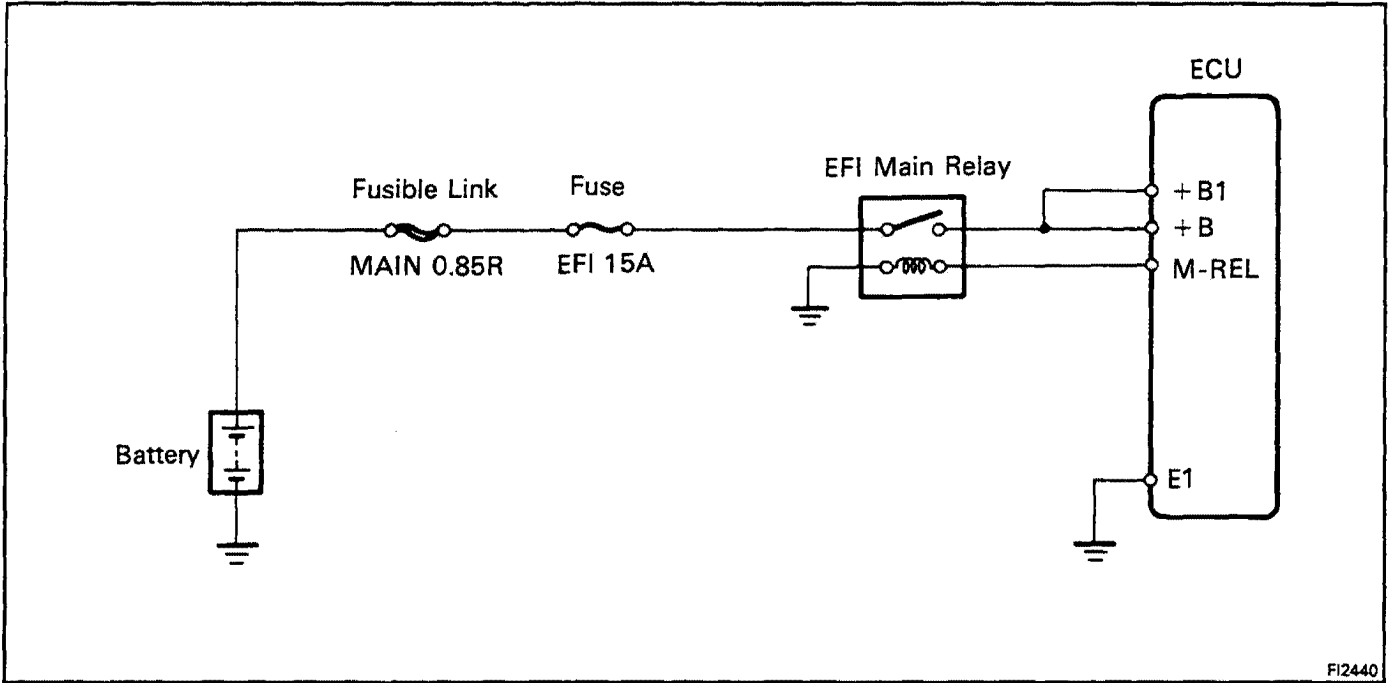

FI2440

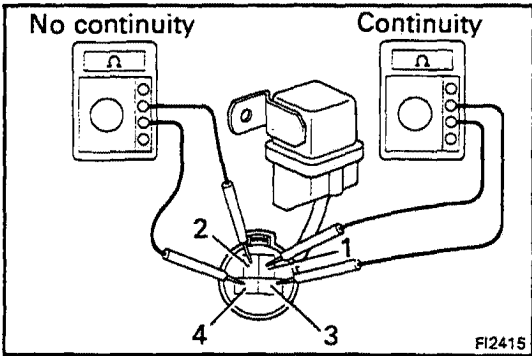

FI2415

## INSPECTION OF EFI MAIN RELAY

### 1. INSPECT RELAY CONTINUITY

- (a) Using an ohmmeter, check that there is continuity between terminals 1 and 3.
- (b) Check that there is no continuity between terminals 2 and 4.

If continuity is not as specified, replace the relay.

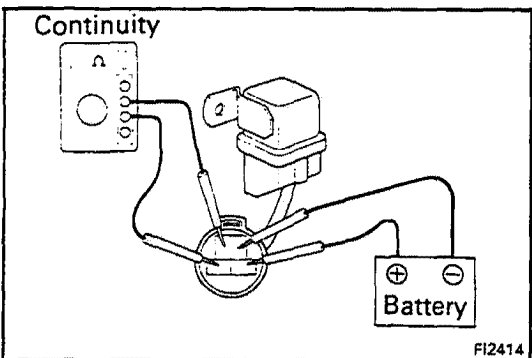

FI2414

### 2. INSPECT RELAY OPERATION

- (a) Apply battery voltage across terminals 1 and 3.
- (b) Using an ohmmeter, check that there is continuity between terminals 2 and 4.

If operation is not as specified, replace the relay.

# Circuit Opening Relay

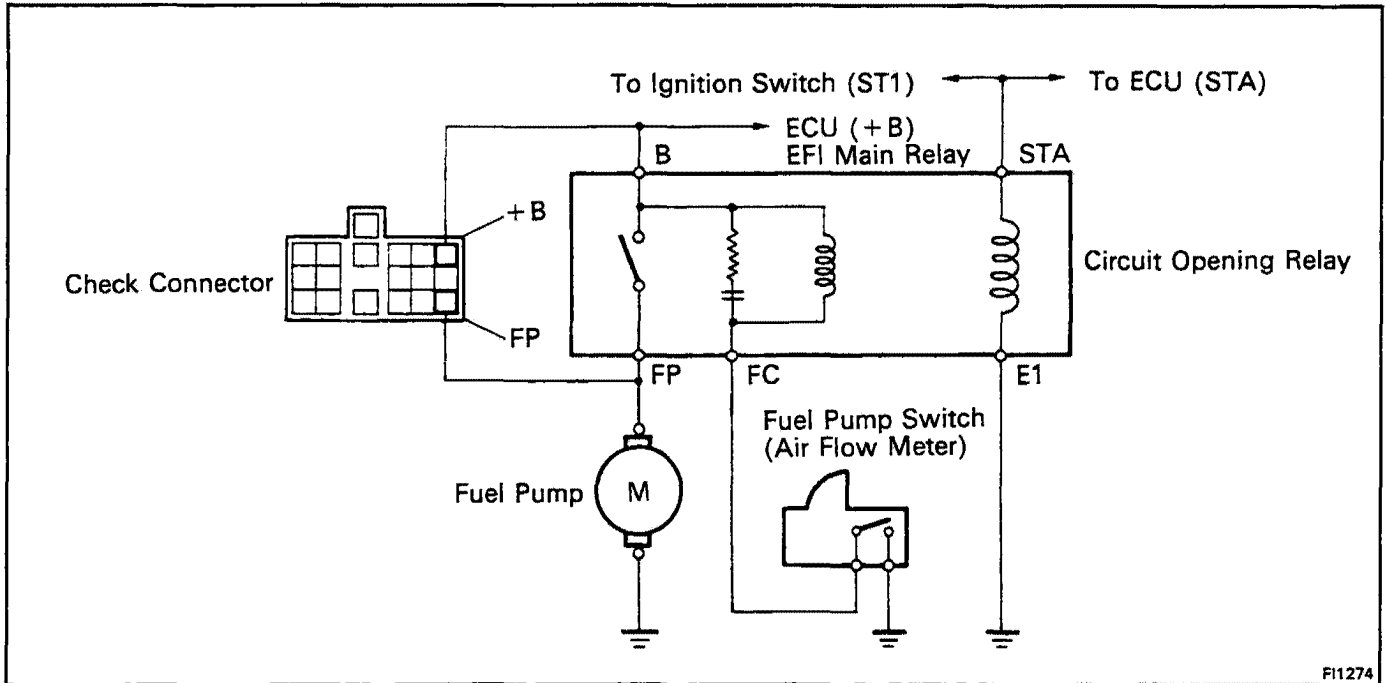

FI1274

## INSPECTION OF CIRCUIT OPENING RELAY

### 1. INSPECT RELAY CONTINUITY

- (a) Using an ohmmeter, check that there is continuity between terminals STA and E1.
- (b) Check that there is continuity between terminals B and FC.
- (c) Check that there is no continuity between terminals B and FP.

If continuity is not as specified, replace the relay.

### 2. INSPECT RELAY OPERATION

- (a) Apply battery voltage across terminals STA and E1.
- (b) Using an ohmmeter, check that there is continuity between terminals B and FP.

- (c) Apply battery voltage across terminals B and FC.
- (d) Check that there is continuity between terminals B and FP.

If operation is not as specified, replace the relay.

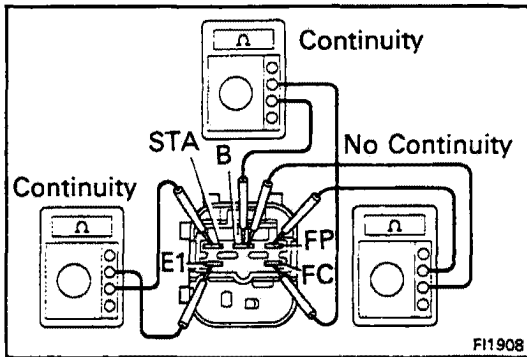

FI1908

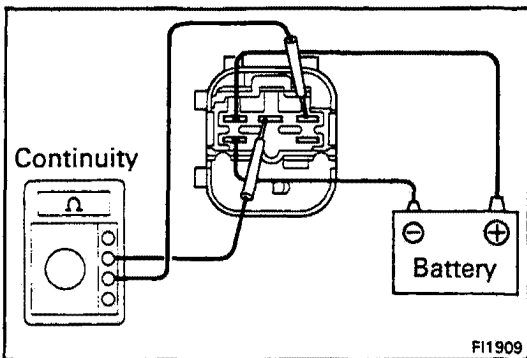

FI1909

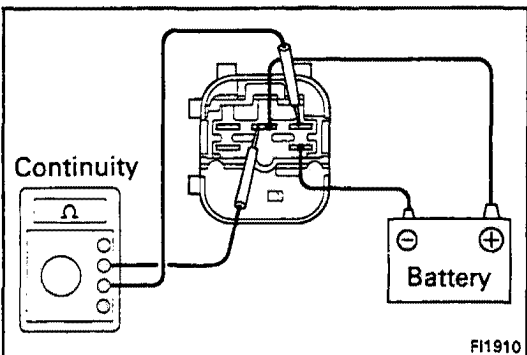

FI1910

# Cold Start Injector Time Switch

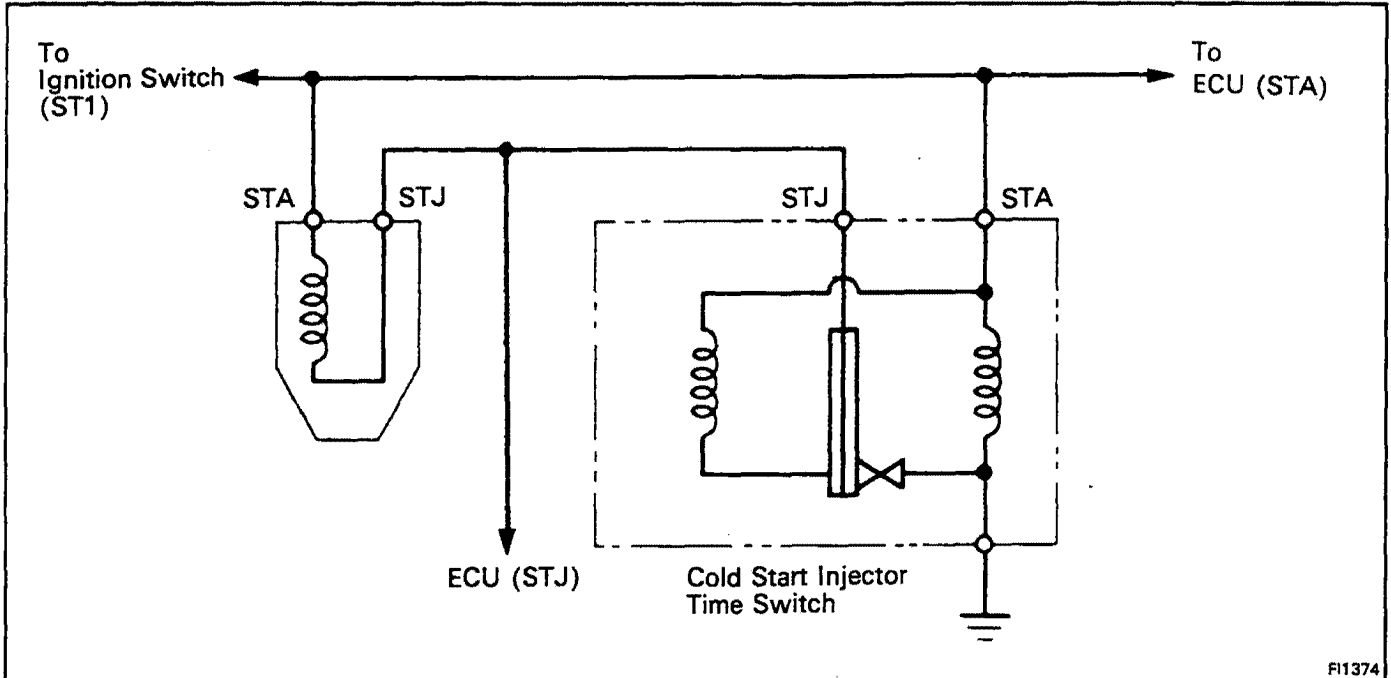

F11374

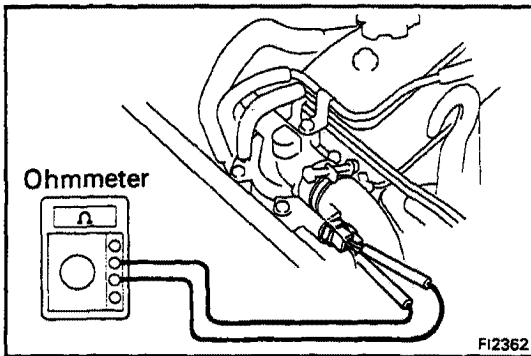

F12362

## INSPECTION OF COLD START INJECTOR TIME SWITCH

### INSPECT RESISTANCE OF COLD START INJECTOR TIME SWITCH

Using an ohmmeter, measure the resistance between each terminal.

**STA – STJ**      30 – 50 Ω below 15°C (59°F)  
                          70 – 90 Ω above 30°C (86°F)

**STA – Ground**   30 – 90 Ω

If the resistance is not as specified, replace the switch.

# Water Temperature Sensor

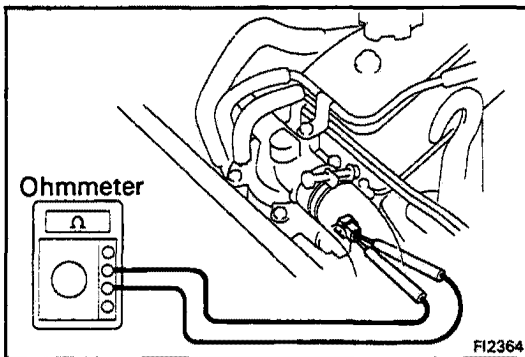
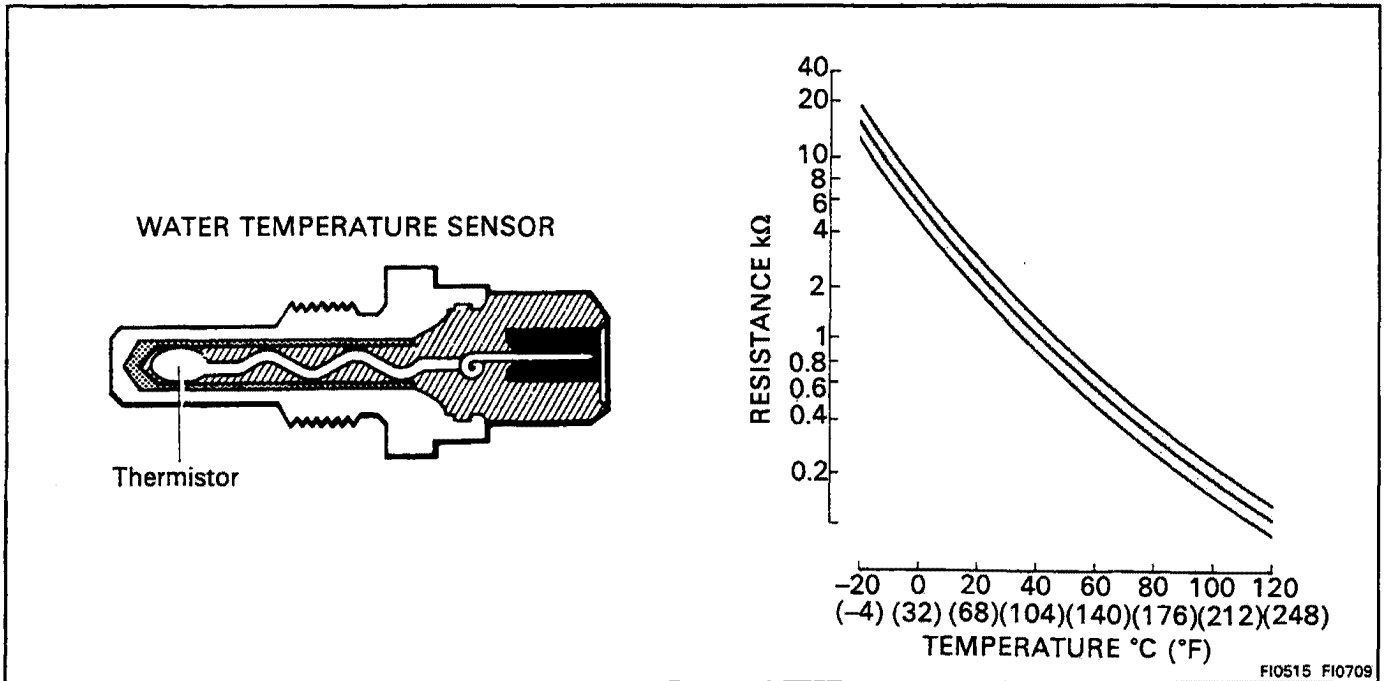

## INSPECTION OF WATER TEMPERATURE SENSOR

### INSPECT RESISTANCE OF WATER TEMPERATURE SENSOR

Using an ohmmeter, measure the resistance between the terminals.

**Resistance: Refer to chart**

If the resistance is not as specified, replace the sensor.

# High Temperature Line Pressure Up System

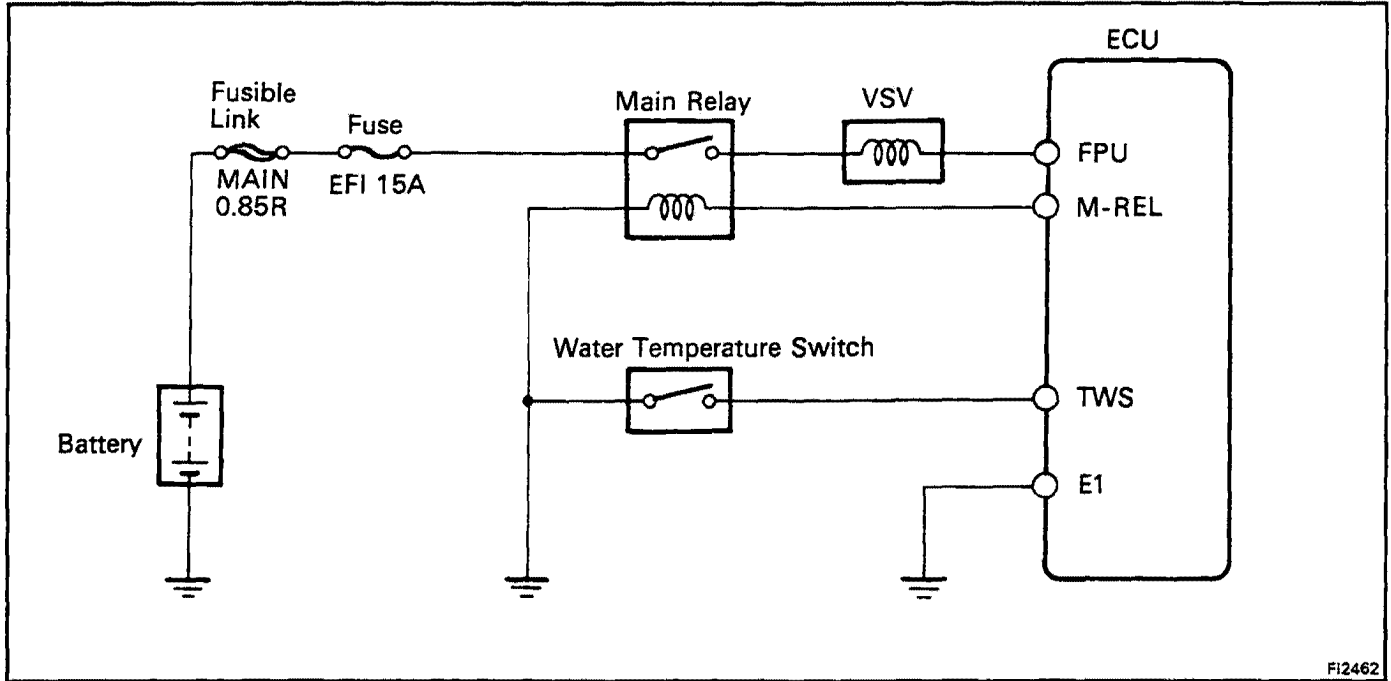

FI2462

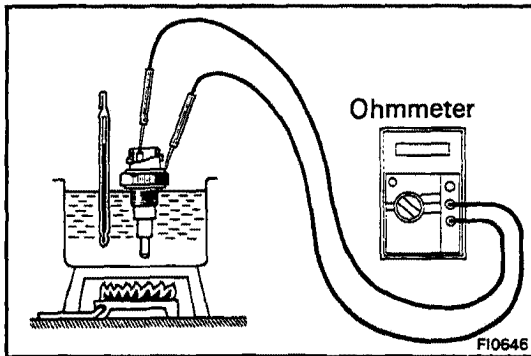

FI0646

## INSPECTION OF HIGH TEMPERATURE LINE UP SYSTEM

### 1. INSPECT WATER TEMPERATURE SWITCH

- (a) Using an ohmmeter, check that there is no continuity between the terminal and body when the oil temperature is below 98°C (208°F).
- (b) Check that there is continuity between the terminal and body when the oil temperature is above 105°C (221°F).

If operation is not as specified, replace the switch.

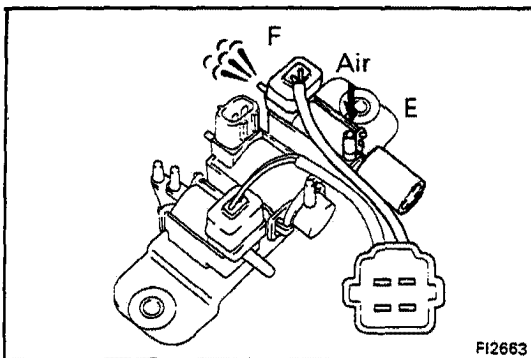

FI2663

### 2. INSPECT VSV

- (a) Check that air flows from the pipe E to pipe F.

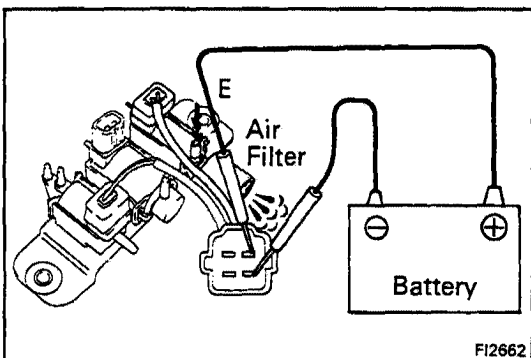

FI2662

- (b) Apply battery voltage across the terminals.
  - (c) Check that air flows from pipe E to air filter.
- If operation is not as specified, replace the VSV.

# EGR Gas Temperature Sensor (California vehicles only)

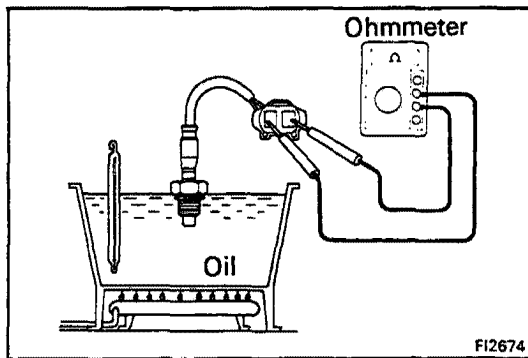
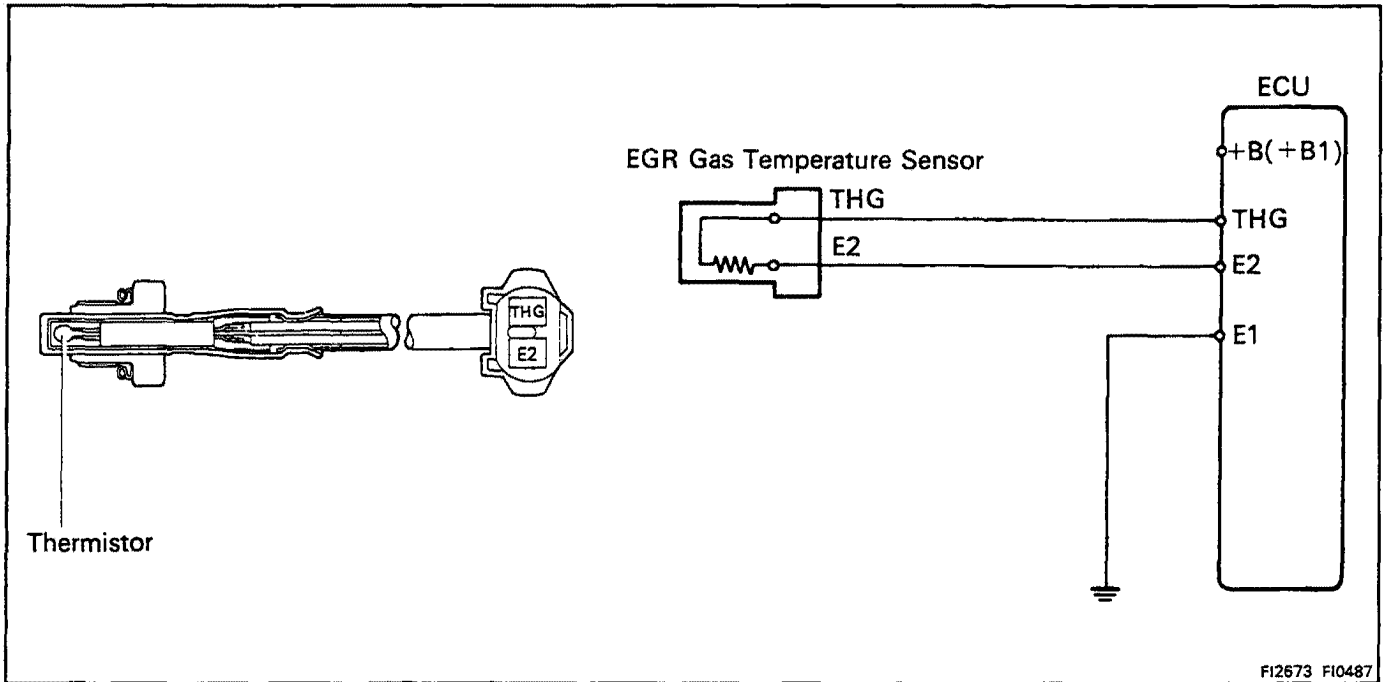

## INSPECTION OF EGR GAS TEMPERATURE SENSOR

### INSPECT EGR GAS TEMPERATURE SENSOR

Using an ohmmeter, measure the resistance between the terminals.

**Resistance:**

69.40 – 88.50 kΩ at 50°C (112°F)

11.89 – 14.37 kΩ at 100°C (212°F)

2.79 – 3.59 kΩ at 150°C (302°F)

If the resistance is not as specified, replace the sensor.

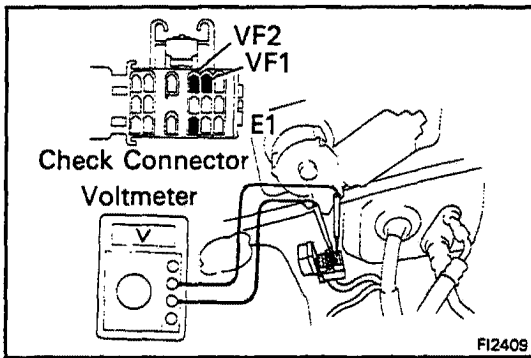

# Oxygen Sensors

## INSPECTION OF OXYGEN SENSOR

### 1. WARM UP ENGINE

Allow the engine to reach normal operating temperature.

### 2. INSPECT FEEDBACK VOLTAGE

Connect the positive (+) probe of a voltmeter to terminal VF1 of the check connector, and negative (-) probe to terminal E1. Perform the test as follows:

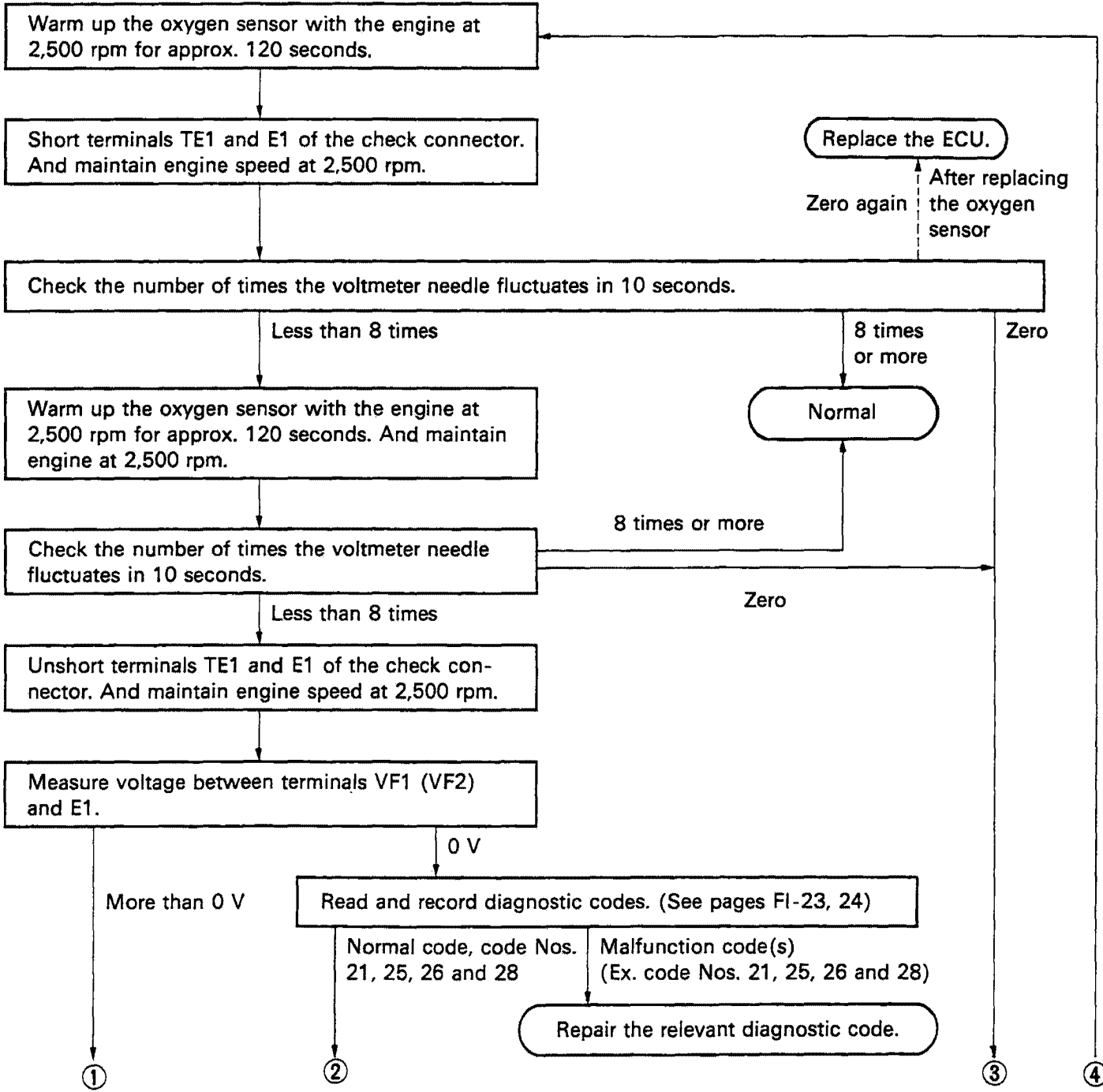

CONTINUED FROM PAGE FI-80

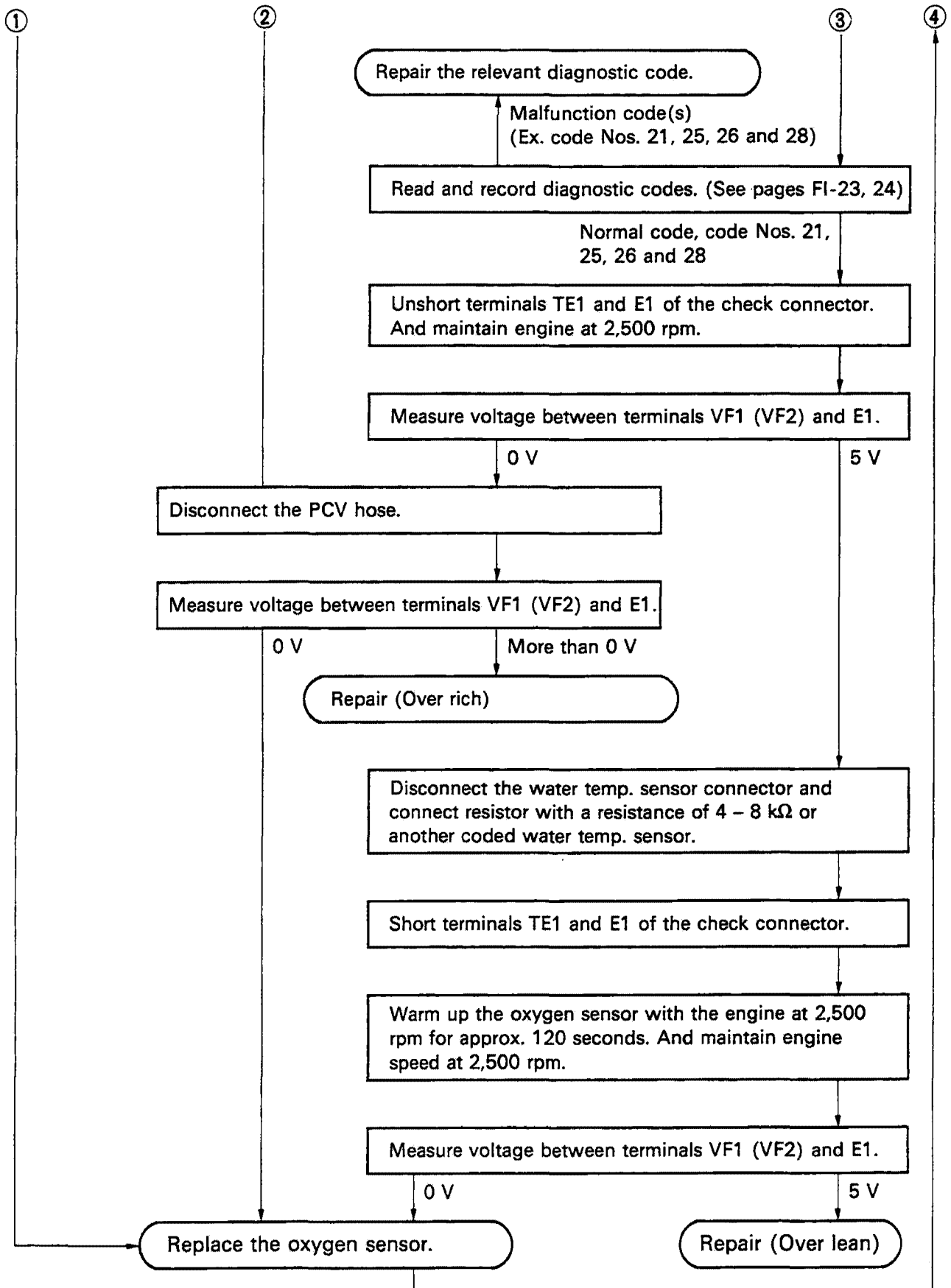

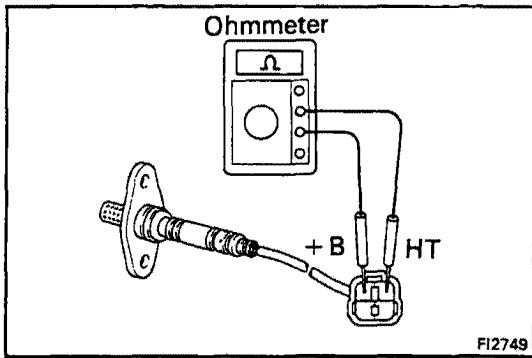

**3. INSPECT HEATER RESISTANCE OF OXYGEN SENSOR**

Using an ohmmeter, measure the resistance between the terminal + B and HT.

**Resistance (Cold): 5.1 – 6.3 Ω**

If the resistance is not as specified, replace the sensor.

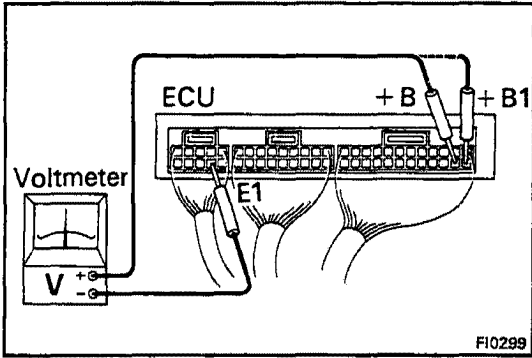

**Electronic Controlled Unit (ECU)**

**INSPECTION OF ECU**

**NOTE:** The EFI circuit can be checked by measuring the and voltage at the wiring connectors of the ECU.

**1. INSPECT VOLTAGE OF ECU**

Check the voltage between each terminal of the wiring connectors.

- Turn the ignition switch ON.
- Measure the voltage at each terminal.

**NOTE:**

- Perform all voltage measurements with the connectors connected.
- Verify that the battery voltage is 11V or more when the ignition switch is ON.

**Voltage at ECU Wiring Connectors**

Terminals	STD Voltage	Condition	
BATT – E1	10 – 14	—	
IG S/W – E1		Ignition S/W ON	
M-REL – E1			
+ B (+ B1) – E1			
IDL – E2	4 – 6	Ignition S/W ON	Throttle valve open
VC – E2	4 – 6		—
VTA – E2	0.1 – 1.0		Throttle valve fully closed
	4 – 5		Throttle valve fully open
VC – E22	4 – 6	Ignition S/W ON	—
VS – E22	4 – 5		Measuring plate fully closed
	0.02 – 0.08		Measuring plate fully open
	2 – 4		Idling
	0.3 – 1.0	3,000 rpm	

### Voltage at ECU Wiring Connectors (Cont'd)

Terminals	STD Voltage	Condition	
THA – E2	1 – 3	Ignition S/W ON	Intake air temperature 20°C (68°F)
THW – E2	0.1 – 1.0	Ignition S/W ON	Coolant temperature 80°C (176°F)
No. 10 E01 – No. 20 E02	9 – 14	Ignition S/W ON	
STA – E1	6 – 14	Cranking	
ISC1 – E1 ISC4	9 – 14	Ignition S/W ON	
IGT – E1	0.7 – 1.0	Idling	
W – E1	8 – 14	No trouble ("CHECK" engine warning light off) and engine running	
A/C – E1	10 – 14	Air conditioning ON	
T – E1	4 – 6	Ignition S/W ON	Check connector TE1-E1 not short
	0		Check connector TE1-E1 short
NSW – E1	0	Ignition S/W ON	Shift position P or N range
	10 – 14		Ex. P or N range
4WD – E1	10 – 14	Ignition S/W ON	4WD S/W ON
	0		4WD S/W OFF
STP – E1	10 – 14	Ignition S/W ON	Stop light S/W ON
	0		Stop light S/W OFF

**ECU Terminals**

E01		No. 10	HT1	STJ	T	ISC 1	ISC 2	G ⊖	G1	NE	THG	OX1	THW	IGF	IGT	M-REL	EGR	SPD	FPU	THA	VS	VC	BATT	IG S/W
E02		No. 20	HT2	E1	TWS	ISC 3	ISC 4	VF1	VF2	VTA	IDL	E11	OX2	E2	E22	4WD	STP	A/C	W	NSV	STA	AI	+B	+B1

\* California vehicles only

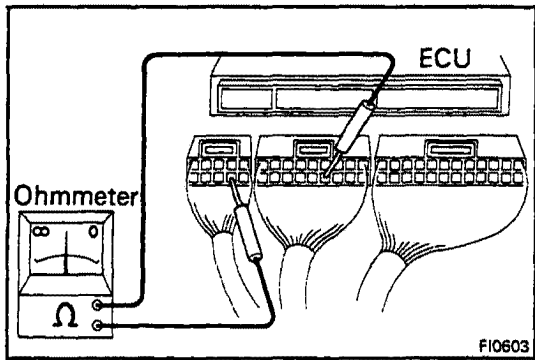

**2. INSPECT RESISTANCE OF ECU**

**CAUTION:**

- Do not touch the ECU terminals.
- The tester probe should be inserted into the wiring connector from the wiring side.

Check the resistance between each terminal of the wiring connectors.

- Disconnect the connectors from the ECU.
- Measure the resistance at each terminal.

**Resistance of ECU Wiring Connectors**

Terminals	Condition	Resistance (Ω)
IDL – E2	Throttle valve open	∞
	Throttle valve fully closed	Less than 2,300
VTA – E2	Throttle valve open	3,500 – 10,300
	Throttle valve fully closed	300 – 6,300
VC – E2	—	4,250 – 8,250
VC – E22	—	200 – 400
VS – E22	Measuring plate fully closed	20 – 600
	Measuring plate fully open	20 – 3,000
THA – E2	Intake air temperature 20°C (68°F)	2,000 – 3,000
THW – E2	Coolant temperature 80°C (176°F)	200 – 400
G1 – G⊖	—	140 – 180
NE – G⊖	—	
ISC1, ISC2 ISC3, ISC4 – +B	—	10 – 30

**ECU Terminals**

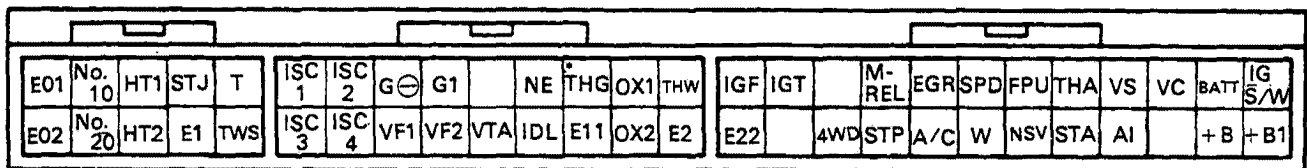

\* California vehicles only

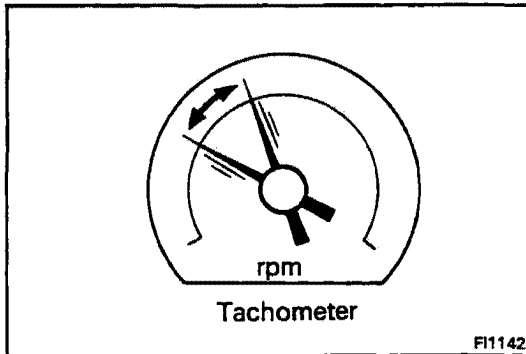
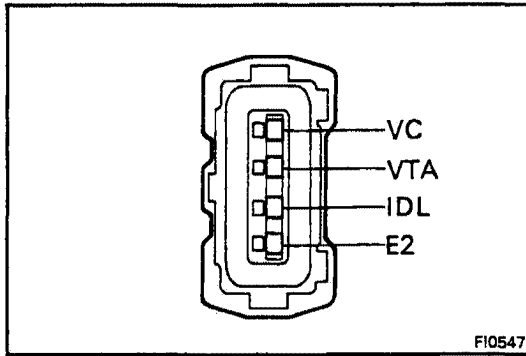

## Fuel Cut RPM

### INSPECTION OF FUEL CUT RPM

#### 1. WARM UP ENGINE

Allow the engine to reach normal operating temperature.

#### 2. INSPECT FUEL CUT RPM

- (a) Disconnect the connector from the throttle position sensor.
- (b) Short terminals IDL and E2 of the wiring connector.
- (c) Gradually raise the engine rpm and check that there is fluctuation between the fuel cut and fuel return points.

NOTE: The vehicle should be stopped.

Fuel cut rpm: **1,300 rpm**

Fuel return rpm: **1,000 rpm**



---

# COOLING SYSTEM

	Page
TRUBLESHOOTING .....	CO-2
CHECK AND REPLACEMENT OF ENGINE COOLANT .....	CO-3
WATER PUMP .....	CO-4
THERMOSTAT .....	CO-9
RADIATOR .....	CO-10
ENGINE COMPARTMENT COOLING FAN ..	CO-13

## TROUBLESHOOTING

Problem	Possible cause	Remedy	Page
Engine overheats	Fan belt loose or missing	Adjust or replace belt	CH-3
	Dirt, leaves or insects on radiator or condenser	Clean radiator or condenser	
	Hoses, water pump, thermostat housing, radiator, heater, core plugs or head gasket leakage	Repair as necessary	
	Thermostat faulty	Check thermostat	CO-9
	Ignition timing retarded	Set timing	IG-11
	Fluid coupling faulty	Replace fluid coupling	
	Radiator hose plugged or rotted	Replace hose	
	Water pump faulty	Replace water pump	CO-4
	Radiator plugged or cap faulty	Check radiator	CO-10
Cylinder head or block cracked or plugged	Repair as necessary		

**NOTE:** The thermostat on the 3F-E engines is equipped with a by-pass valve essential to the cooling system. Therefore, if the engine tends to overheat, removal of the thermostat will adversely effect cooling efficiency.

## CHECK AND REPLACEMENT OF ENGINE COOLANT

### 1. CHECK ENGINE COOLANT LEVEL AT RESERVE TANK

The coolant level should be between the "LOW" and "FULL" lines.

If low, check for leaks and add coolant up to the "FULL" line.

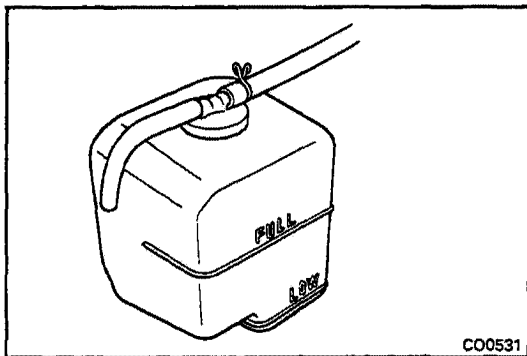

### 2. CHECK ENGINE COOLANT QUALITY

There should not be any excessive rust deposits or scales around the radiator cap or radiator filler hole, and the coolant should be free from oil.

If excessively dirty, replace the coolant.

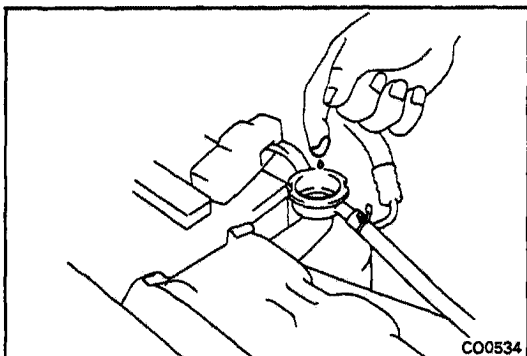

### 3. REPLACE ENGINE COOLANT

(a) Remove the radiator cap.

(b) Drain the coolant from the radiator and engine drain cocks.

(c) Close the drain cocks.

**Torque (Engine drain cock):**

**450 kg-cm (33 ft-lb, 44 N·m)**

(d) Fill the system with coolant.

Use a good brand of ethylene-glycol base coolant, mixed according to the manufacturer's directions.

**Capacity:**

w/ Front heater

**17.5 liters (18.5 US qts, 15.4 Imp. qts)**

w/ Front and rear heaters

**19.5 liters (20.6 US qts, 17.2 Imp. qts)**

(e) Install the radiator cap.

(f) Start the engine and check for leaks.

(g) Recheck the coolant level and refill as necessary.

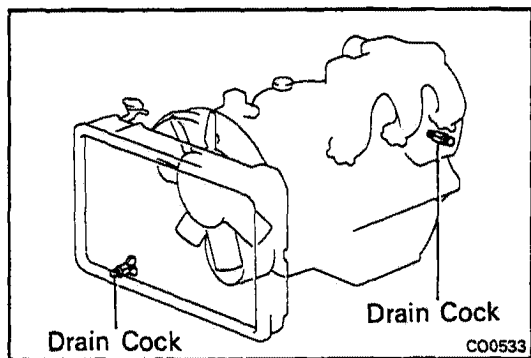

# WATER PUMP COMPONENTS

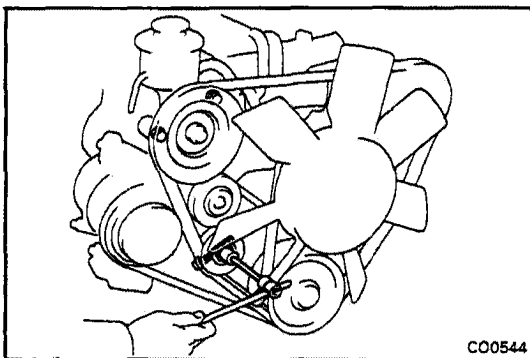
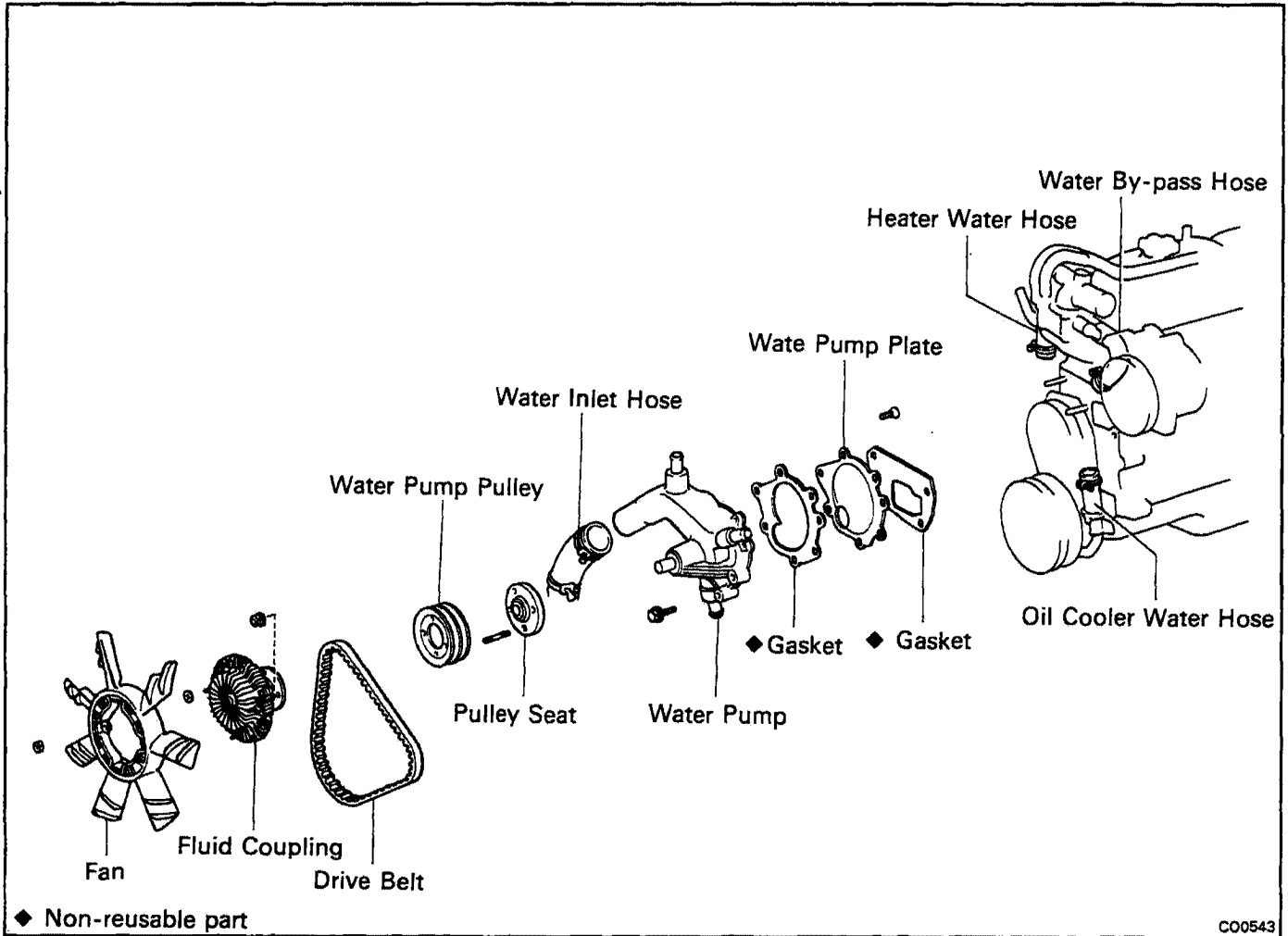

## REMOVAL OF WATER PUMP

- 1. DRAIN ENGINE COOLANT (See page CO-3)**
- 2. REMOVE PS DRIVE BELT**  
Loosen the PS mount, idler pulley and adjusting bolts, and remove the drive belt.
- 3. DISCONNECT COOLANT RESERVOIR HOSE**
- 4. DISCONNECT RADIATOR INLET HOSE**
- 5. REMOVE FAN SHROUD BOLTS**

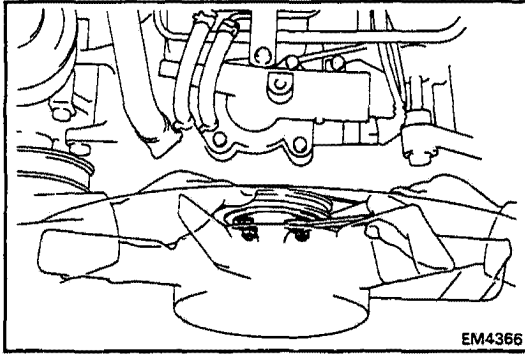

6. **REMOVE ALTERNATOR DRIVE BELT, FAN, FLUID COUPLING AND WATER PUMP PULLEY**
  - (a) Remove the four nuts holding the fluid coupling to the pulley seat.
  - (b) Loosen the alternator adjusting lock bolt, adjusting bolt, pivot bolt and nut, and remove the drive belt.
  - (c) Pull out the fan and fluid coupling with the fan shroud.
  - (d) Remove the fan from the fluid coupling.
7. **REMOVE ALTERNATOR (See page CH-6)**
8. **REMOVE A/C DRIVE BELT**
9. **DISCONNECT HOSES FROM WATER PUMP**
  - (a) Water inlet hose
  - (b) Water by-pass hose
  - (c) Heater water hose
  - (d) Oil cooler water hoses

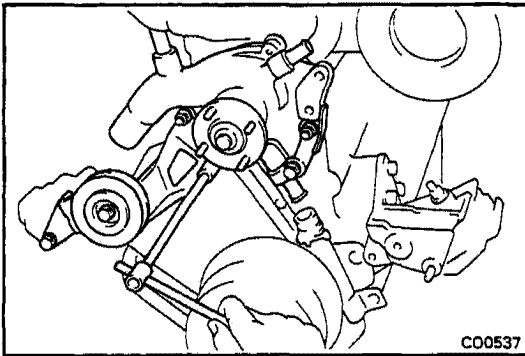

10. **REMOVE WATER PUMP, PS IDLER PULLEY WITH BRACKET ASSEMBLY AND ALTERNATOR STAY BRACKET**
  - (a) Remove the bolt, two nuts and PS idler pulley with bracket assembly.
  - (b) Remove the bolt, nut, alternator stay bracket, water pump and gasket.

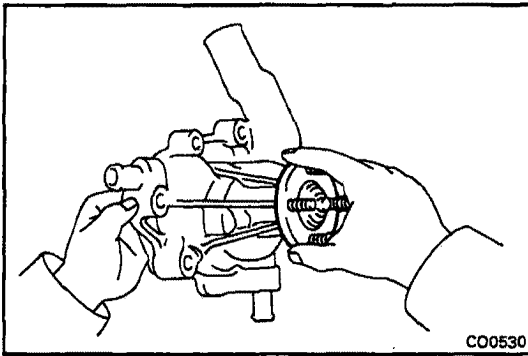

## INSPECTION OF WATER PUMP COMPONENTS

### 1. INSPECT WATER PUMP

Turn the pulley seat and check that the water pump bearing is not rough or noisy.

If necessary, replace the water pump.

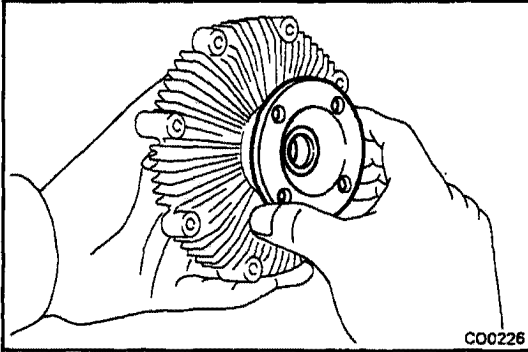

### 2. INSPECT FLUID COUPLING

Check that the fluid coupling is not damaged and that no silicon oil leaks.

If necessary, replace the fluid coupling.

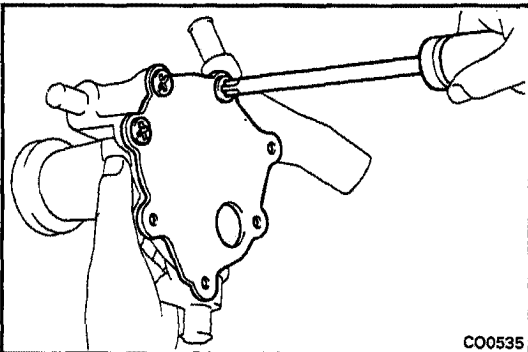

## DISASSEMBLY OF WATER PUMP

(See page CO-4)

### 1. REMOVE WATER PUMP PLATE

Remove the three screws, plate and gasket.

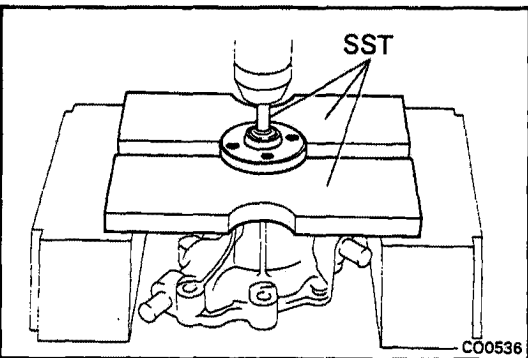

### 2. REMOVE PULLEY SEAT

(a) Remove the stud bolts.

(b) Using SST and a press, press the shaft of the bearing and remove the pulley seat.

SST 09236-00101 (09237-00010, 09237-00050)

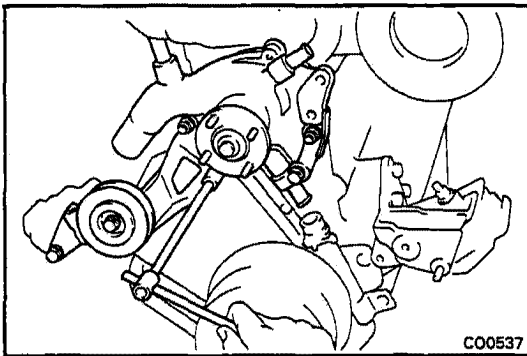
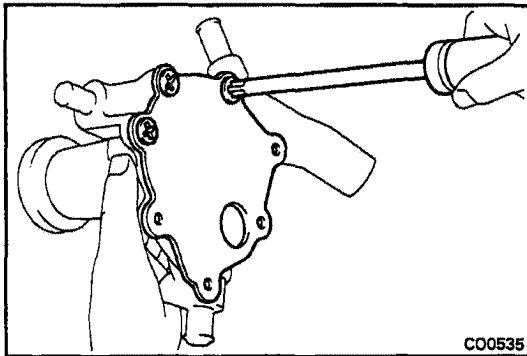
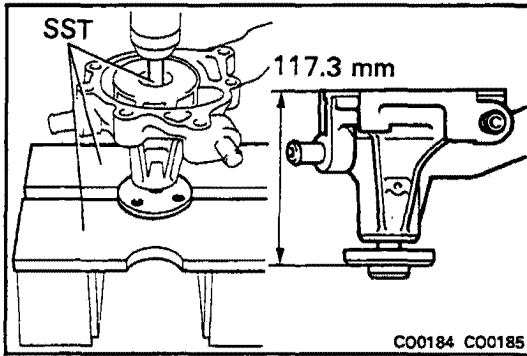

## ASSEMBLY OF WATER PUMP

(See page CO-4)

### 1. INSTALL WATER PUMP SEAT

- (a) Using SST and a press, press the shaft of the bearing and install the pulley seat to a distance specified below from the water pump body edge.

SST 09236-00101 (09237-00010, 09237-00050)

Distance: 117.3 mm (4.618 in.)

- (b) Install the stud bolts.

### 2. INSTALL WATER PUMP PLATE

Install a new gasket and the water pump plate with the three screws.

## INSTALLATION OF WATER PUMP

(See page CO-4)

### 1. INSTALL WATER PUMP, PS IDLER PULLEY WITH BRACKET ASSEMBLY AND ALTERNATOR STAY BRACKET

- (a) Temporarily install a new gasket, the water pump and alternator stay bracket with the bolt and nut.
- (b) Temporarily install the PS idler pulley with bracket assembly with the bolt and nuts.
- (c) Torque the water pump mounting bolt and nuts.

Torque: 380 kg-cm (27 ft-lb, 37 N·m)

### 2. INSTALL AND ADJUST A/C DRIVE BELT (See page MA-4)

### 3. CONNECT HOSES TO WATER PUMP

- (a) Water inlet hose
- (b) Water by-pass hose
- (c) Heater water hose
- (d) Oil cooler water hose

### 4. INSTALL ALTERNATOR (See page CH-14)

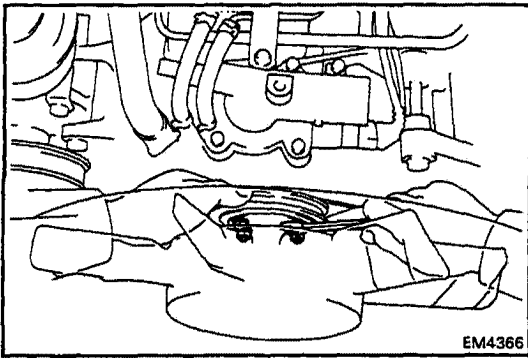

5. **INSTALL WATER PUMP PULLEY, FLUID COUPLING, FAN AND ALTERNATOR DRIVE BELT**
  - (a) Install fan to the fluid coupling.
  - (b) Place the fan shroud together with the fluid coupling in the position.
  - (c) Install the water pump pulley and fluid coupling with the four nuts.
  - (d) Place the drive belt onto each pulley.
  - (e) Stretch the belt tight and tighten the four nuts.
  - (f) Adjust the water pump drive belt tension.  
(See page MA-4)
6. **INSTALL FAN SHROUD BOLTS**
7. **CONNECT RADIATOR INLET HOSE**
8. **CONNECT COOLANT RESERVOIR HOSE**
9. **INSTALL AND ADJUST PS DRIVE BELT**  
(See page MA-4)
10. **FILL WITH ENGINE COOLANT (See page CO-3)**
11. **START ENGINE AND CHECK FOR LEAKS**

# THERMOSTAT

## REMOVAL OF THERMOSTAT

1. DRAIN ENGINE COOLANT (See page CO-4)
2. DISCONNECT RADIATOR INLET AND WATER BY-PASS HOSES FROM WATER OUTLET
3. DISCONNECT TWO VACUUM HOSES OF BVSV
4. DISCONNECT COLD START INJECTOR TIME SWITCH AND WATER TEMPERATURE SWITCH CONNECTORS
5. REMOVE WATER OUTLET
  - (a) Remove the clamp bolt of ISC water by-pass pipe.
  - (b) Remove the four bolts, water outlet and gasket.
6. REMOVE THERMOSTAT

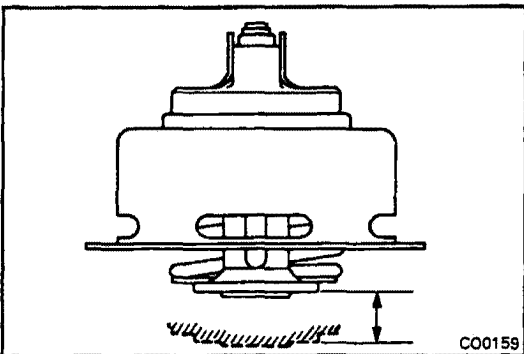
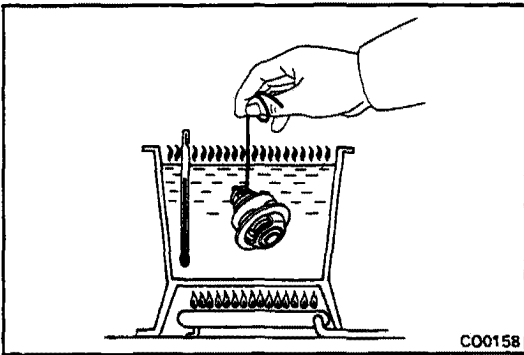
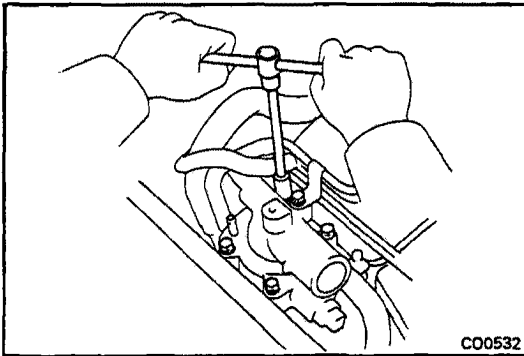

## INSPECTION OF THERMOSTAT

### INSPECT THERMOSTAT

NOTE: The thermostat is numbered with the valve opening temperature.

- (a) Immerse the thermostat in water and gradually heat the water.

- (b) Check the valve opening temperature.

**Valve opening temperature: 86 – 90°C  
(187 – 194°F)**

If the valve opening temperature is not within specification, replace the thermostat.

- (c) Check the valve lift.

**Valve lift:**

**10 mm (0.39 in.) or more at 100°C (212°F)**

If the valve lift is less than specification, replace the thermostat.

- (d) Check that the valve spring is tight when the thermostat is fully closed.

If necessary, replace the thermostat.

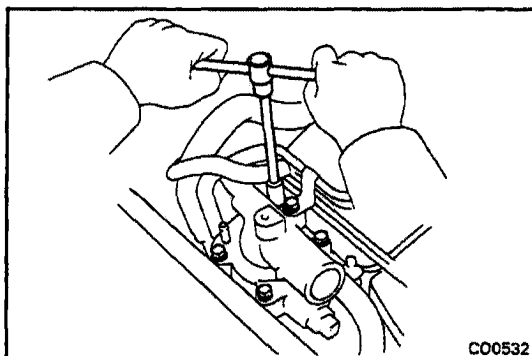

## INSTALLATION OF THERMOSTAT

1. PLACE THERMOSTAT IN WATER OUTLET HOUSING
2. INSTALL WATER OUTLET
  - (a) Install a new gasket and the water outlet with the four bolts. Torque the bolts.  
Torque: 185 kg-cm (13 ft-lb, 18 N·m)
  - (b) Install the clamp bolt of ISC water by-pass pipe.
3. CONNECT COLD START INJECTOR TIME SWITCH AND WATER TEMPERATURE SWITCH CONNECTORS
4. CONNECT TWO VACUUM HOSES OF BVSV
5. CONNECT RADIATOR INLET AND WATER BY-PASS HOSES
6. FILL WITH ENGINE COOLANT (See page CO-4)
7. START ENGINE AND CHECK FOR LEAKS

## RADIATOR

### CLEANING OF RADIATOR

#### CLEAN RADIATOR

Using water or steam cleaner, remove any mud and dirt from the radiator core.

**CAUTION:** If using a high pressure type cleaner, be careful not to deform the fins of the radiator core. If the cleaner nozzle pressure is 30 – 35 kg/cm<sup>2</sup> (427 – 498 psi, 2,942 – 3,432 kPa), keep a distance of at least 40 – 50 cm (15.75 – 19.69 in.) between the radiator core and cleaner nozzle.

### INSPECTION OF RADIATOR

#### 1. INSPECT RADIATOR CAP

Using a radiator cap tester, pump the tester until the relief valve opens. Check that the valve opens between 0.75 kg/cm<sup>2</sup> (10.7 psi, 74 kPa) and 1.05 kg/cm<sup>2</sup> (14.9 psi, 103 kPa).

Check that the pressure does not drop rapidly when pressure on the cap is below 0.6 kg/cm<sup>2</sup> (8.5 psi, 59 kPa). If either check is not within limits, replace the cap.

#### 2. INSPECT COOLING SYSTEM FOR LEAKS

- (a) Fill the radiator with coolant and attach a radiator cap tester.
- (b) Warm up the engine.
- (c) Pump it to 1.2 kg/cm<sup>2</sup> (17 psi, 118 kPa), check that pressure does not drop.

If the pressure drops, check for leaks from the hoses, radiator or water pump. If no external leaks are found, check the heater core, block and head.

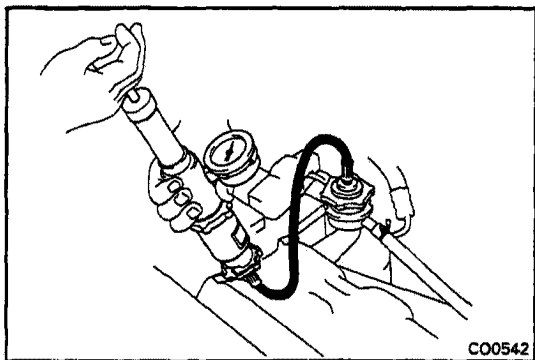
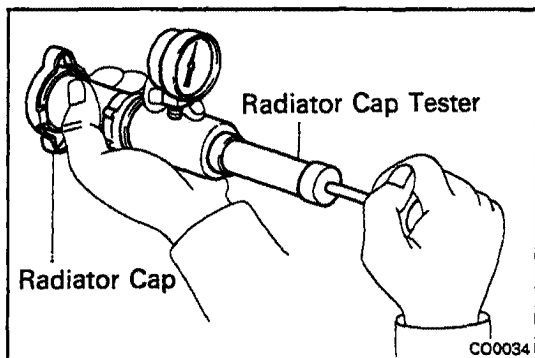

## REMOVAL OF RADIATOR

1. DISCHARGE REFRIGERATION SYSTEM
2. DRAIN ENGINE COOLANT (See page CO-3)
3. REMOVE FRONT TURN SIGNAL LAMP ASSEMBLY, RADIATOR GRILLE AND HEADLAMP DOORS

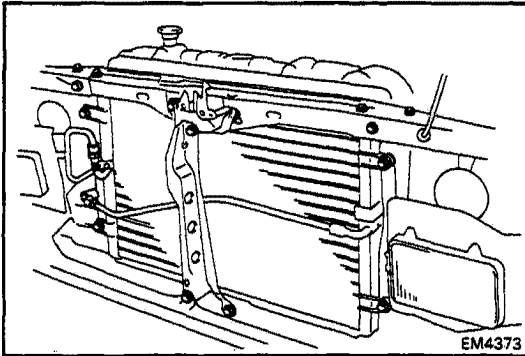

4. REMOVE HOOD ROCK BRACE, HOOD ROCK AND GRILLE CENTER SUPPORT
5. DISCONNECT DISCHARGE HOSE AND LIQUID TUBE

NOTE: Cap the open fittings immediately to keep moisture out of the system.

6. REMOVE COOLER CONDENSER  
Remove the four bolts and condenser.

7. DISCONNECT COOLANT RESERVOIR HOSE

8. DISCONNECT RADIATOR HOSES

9. DISCONNECT A/T OIL COOLER HOSES

NOTE: Be careful as some oil will leak out. Catch it in a suitable container.

10. REMOVE FAN SHROUD MOUNTING BOLTS

11. REMOVE RADIATOR MOUNTING BOLTS, NUTS AND RADIATOR

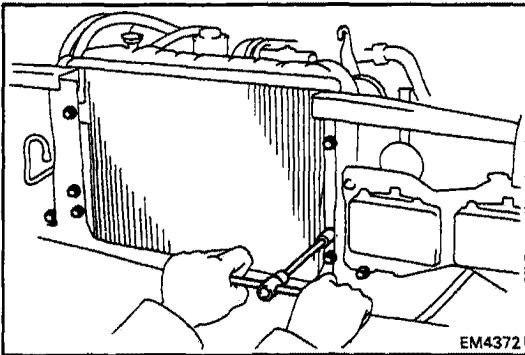

## INSTALLATION OF RADIATOR

1. INSTALL RADIATOR
2. INSTALL FAN SHROUD MOUNTING BOLTS
3. CONNECT A/T OIL COOLER HOSES
4. CONNECT RADIATOR HOSES
5. CONNECT COOLANT RESERVOIR HOSE
6. INSTALL COOLER CONDENSER
7. CONNECT DISCHARGE HOSE AND LIQUID TUBE
8. INSTALL HOOD ROCK BRACE, HOOD ROCK AND GRILLE CENTER SUPPORT

9. FILL WITH ENGINE COOLANT (See page CO-3)
10. EVACUATE, CHARGE AND TEST REFRIGERATION
11. START ENGINE AND CHECK FOR LEAKS

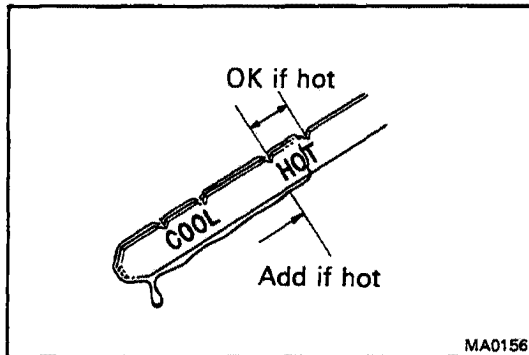

12. CHECK AUTOMATIC TRANSMISSION FLUID LEVEL

Fluid type: ATF DEXRON® II

CAUTION: Do not overfill.

# ENGINE COMPARTMENT COOLING FAN

## ENGINE COMPARTMENT COOLING FAN CIRCUIT

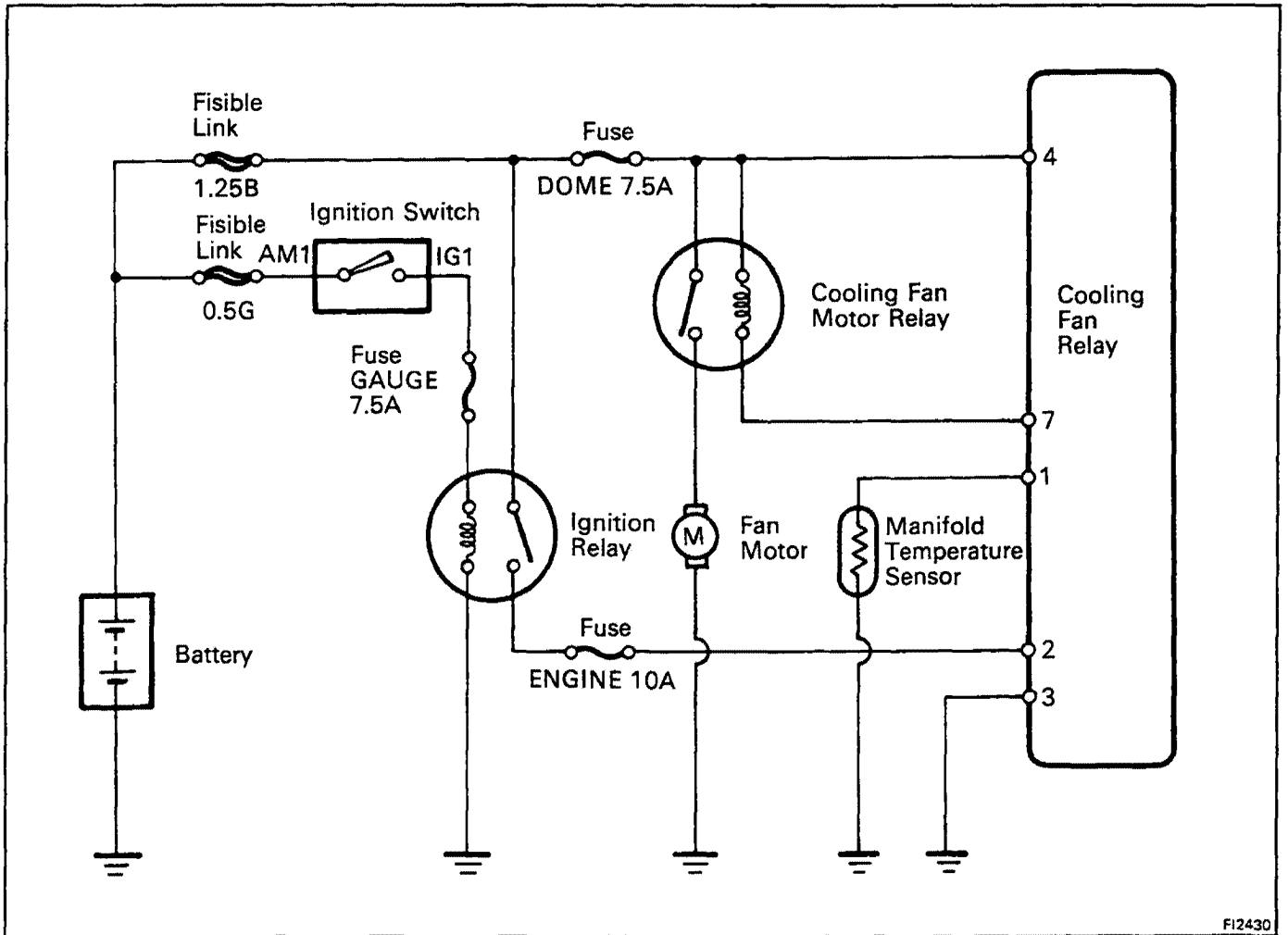

F12430

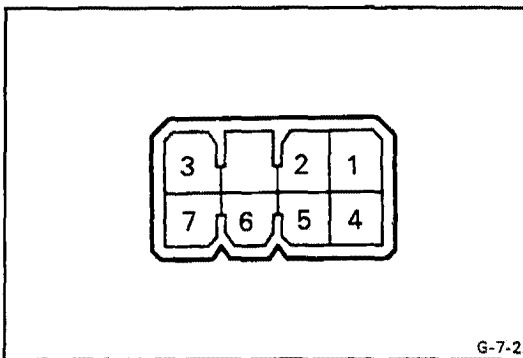

G-7-2

### INSPECTION OF ENGINE COMPARTMENT COOLING FAN COMPONENTS

#### Cooling Fan Relay

#### INSPECT COOLING FAN RELAY CIRCUIT

- (a) Remove the driver's cowl side trim.
- (b) Disconnect the relay connector and inspect the connector on wire harness side as shown in the chart below.

Check for	Between terminals	Condition	Specified value
Continuity	1 – Body ground	Always	Continuity
Voltage	2 – Body ground	Ignition switch ON	Battery voltage
Continuity	3 – Body ground	Always	Continuity
Voltage	4 – Body ground	Always	Battery voltage
Voltage	7 – Body ground	Fan motor does not operate	Battery voltage

## Cooling Fan Motor Relay

**LOCATION:** Inside of the driver's cowl side trim.

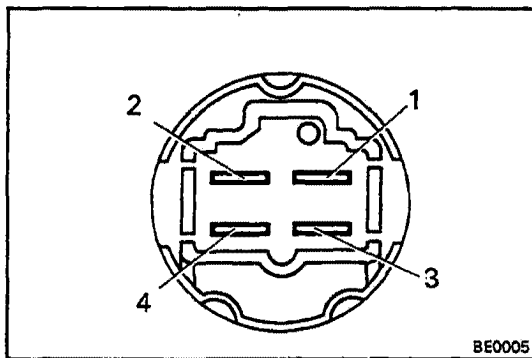

### INSPECT COOLING FAN MOTOR RELAY

#### A. Inspect relay continuity

- (a) Check that there is continuity between terminals 1 and 3.
- (b) Check that there is no continuity between terminals 2 and 4.

If continuity is not as specified, replace the relay.

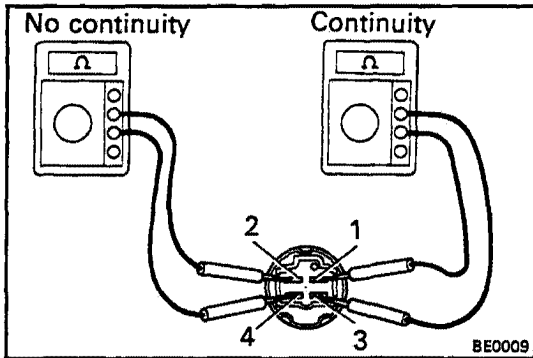

#### B. Inspect relay operation

- (a) Apply battery voltage across terminals 1 and 3.
- (b) Check that there is continuity between terminals 2 and 4.

If operation is not as described, replace the relay.

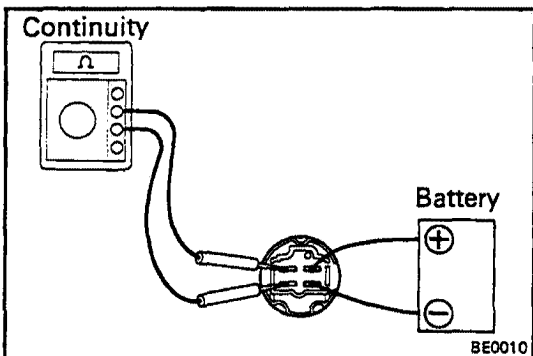

## Ignition relay

**LOCATION:** Under the instrument panel on the driver's side.

### INSPECT IGNITION RELAY

(Refer to the cooling fan motor relay)

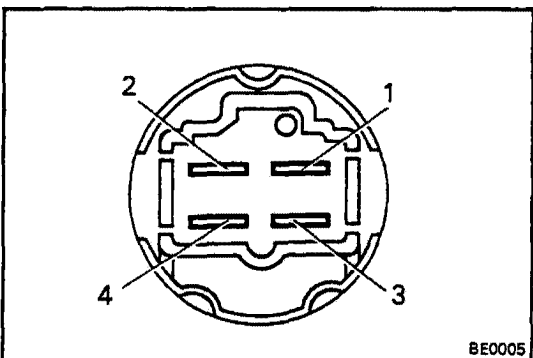

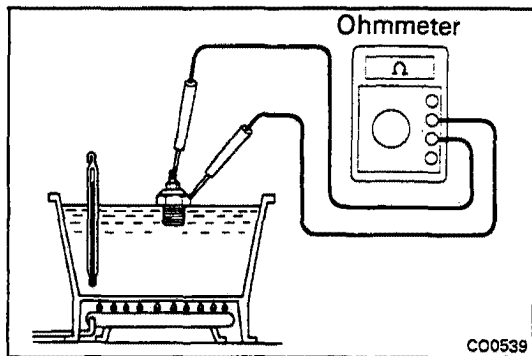

## Manifold Temperature Sensor

**LOCATION:** Near the intake chamber.

### INSPECT MANIFOLD TEMPERATURE SENSOR

Using an ohmmeter, measure the resistance of the temperature sensor terminals.

Oil temperature °C (°F)	Resistance (Ω)
90°C (194°F)	Approx. 4 kΩ
110°C (230°F)	Approx. 2 kΩ

If each resistance value is not as shown in the table above, replace the temperature sensor.

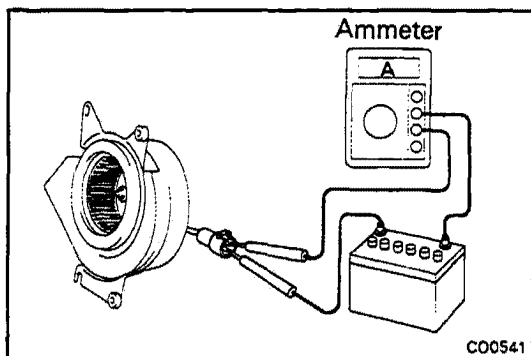

## Fan Motor

### INSPECT FAN MOTOR

- (a) Remove the shroud.
- (b) Connect the battery and ammeter to the fan motor connector.
- (c) Check to see that the motor rotates smoothly, and current is as follows:

**Current: 2.8 – 3.8 A**

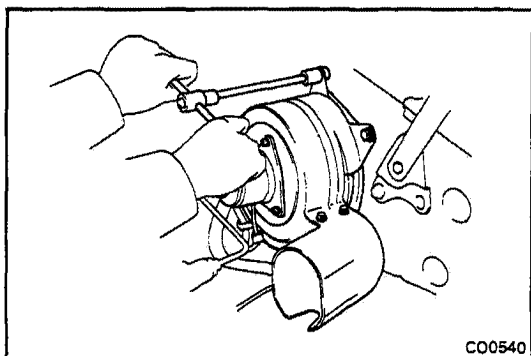

## REMOVAL OF ELECTRIC COOLING FAN

1. DISCONNECT FAN MOTOR CONNECTOR
2. DISCONNECT LH HOOD LOCK BALANCER
3. REMOVE ELECTRIC COOLING FAN

Remove the four bolts and cooling fan.

## INSTALLATION OF ELECTRIC COOLING FAN

1. INSTALL ELECTRIC COOLING FAN
2. CONNECT LH HOOD LOCK BALANCER
3. CONNECT FAN MOTOR CONNECTOR



# LUBRICATION SYSTEM

	Page
TRUBLESHOOTING .....	LU-2
OIL PRESSURE CHECK .....	LU-3
REPLACEMENT OF ENGINE OIL AND OIL FILTER .....	LU-4
OIL PUMP .....	LU-5
OIL COOLER AND RELIEF VALVE .....	LU-12

**LU**

## TROUBLESHOOTING

Problem	Possible cause	Remedy	Page
Oil leakage	Cylinder head, cylinder block or oil pump body damaged or cracked Oil seal faulty Gasket faulty	Repair as necessary Replace oil seal Replace gasket	EM-40, 68
Low oil pressure	Oil leakage Relief valve faulty Oil pump faulty Engine oil poor quality Crankshaft bearing faulty Connecting rod bearing faulty Oil filter clogged	Repair as necessary Repair relief valve Repair oil pump Replace engine oil Replace bearing Replace bearing Replace oil filter	LU-5 LU-5 LU-4 EM-45 EM-45 LU-4
High oil pressure	Relief valve faulty	Repair relief valve	LU-5

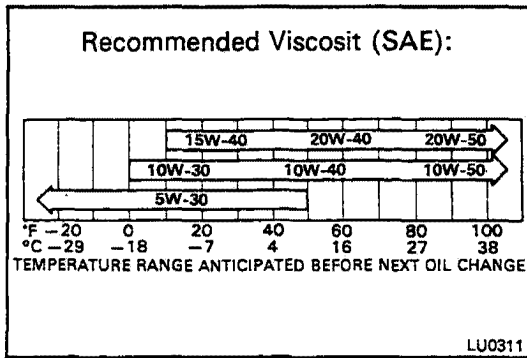

## OIL PRESSURE CHECK

### 1. CHECK ENGINE OIL QUALITY

Check the oil for deterioration, entry of water, discoloring or thinning.

If the quality is poor, replace the oil.

Use API grade SF or SF/CC multigrade, fuel-efficient and recommended viscosity oil.

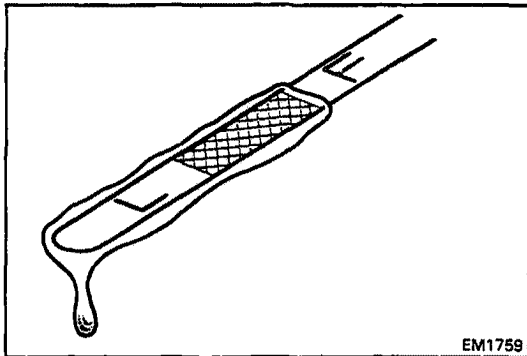

### 2. CHECK ENGINE OIL LEVEL

The oil level should be between the "L" and "F" marks on the dipstick.

If low, check for leakage and add oil up to the "F" mark.

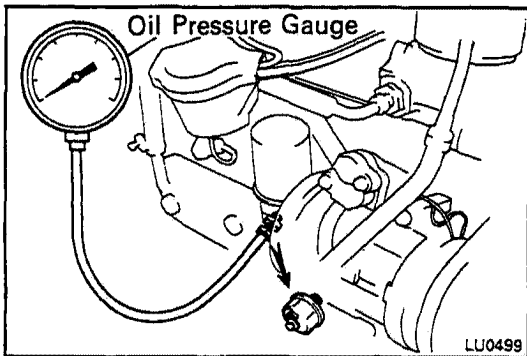

### 3. REMOVE OIL PRESSURE SENDER GAUGE

### 4. INSTALL OIL PRESSURE GAUGE

### 5. START ENGINE

Start engine and warm it up to normal operating temperature.

### 6. CHECK OIL PRESSURE

Oil pressure:

At idle 0.3 kg/cm<sup>2</sup> (4.3 psi, 29 kPa)  
or more

At 4,000 rpm 2.5 – 5.0 kg/cm<sup>2</sup>  
(36 – 71 psi, 245 – 490 kPa)

NOTE: Check for oil leakage after reinstalling the oil pressure sender gauge.

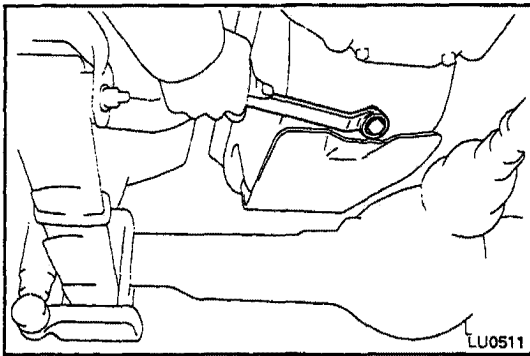

## REPLACEMENT OF ENGINE OIL AND OIL FILTER

### 1. DRAIN ENGINE OIL

- (a) Remove the oil filler cap.
- (b) Remove the oil drain plug and drain the oil into a container.

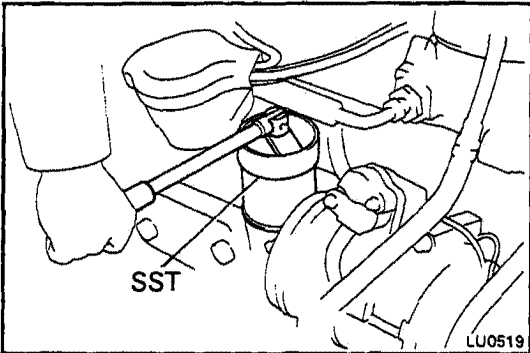

### 2. REPLACE OIL FILTER

- (a) Using SST, remove the oil filter.  
SST 09228-44011

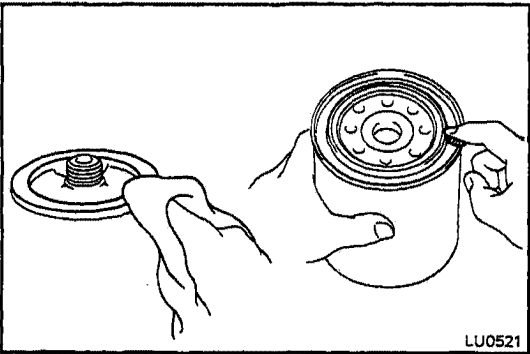

- (b) Check and clean the oil filter installation surface.
- (c) Apply clean engine oil to the gasket of a new oil filter.

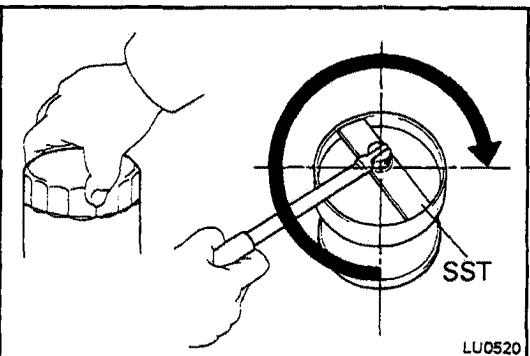

- (d) Lightly screw in the oil filter to where you feel resistance.
- (e) Using SST, tighten the oil filter an extra 3/4 turn.  
SST 09228-44011

### 3. FILL WITH ENGINE OIL

- (a) Clean and install the oil drain plug with a new gasket. Torque the drain plug.  
**Torque: 400 kg-cm (29 ft-lb, 39 N·m)**
- (b) Fill the engine with new oil, API grade SF or SF/CC multigrade viscosity and fuel-efficient oil.

#### Capacity:

##### Drain and refill

w/o Oil filter change

7.0 liters (7.4 US qts, 6.2 Imp. qts)

w/ Oil filter change

7.8 liters (8.2 US qts, 6.9 Imp. qts)

##### Dry fill

8.0 liters (8.5 US qts, 7.0 Imp. qts)

- (c) Install the oil filler cap with the gasket.

### 4. START ENGINE AND CHECK FOR LEAKS

### 5. RECHECK ENGINE OIL LEVEL

Recheck the engine oil level and refill if necessary.

# OIL PUMP COMPONENTS

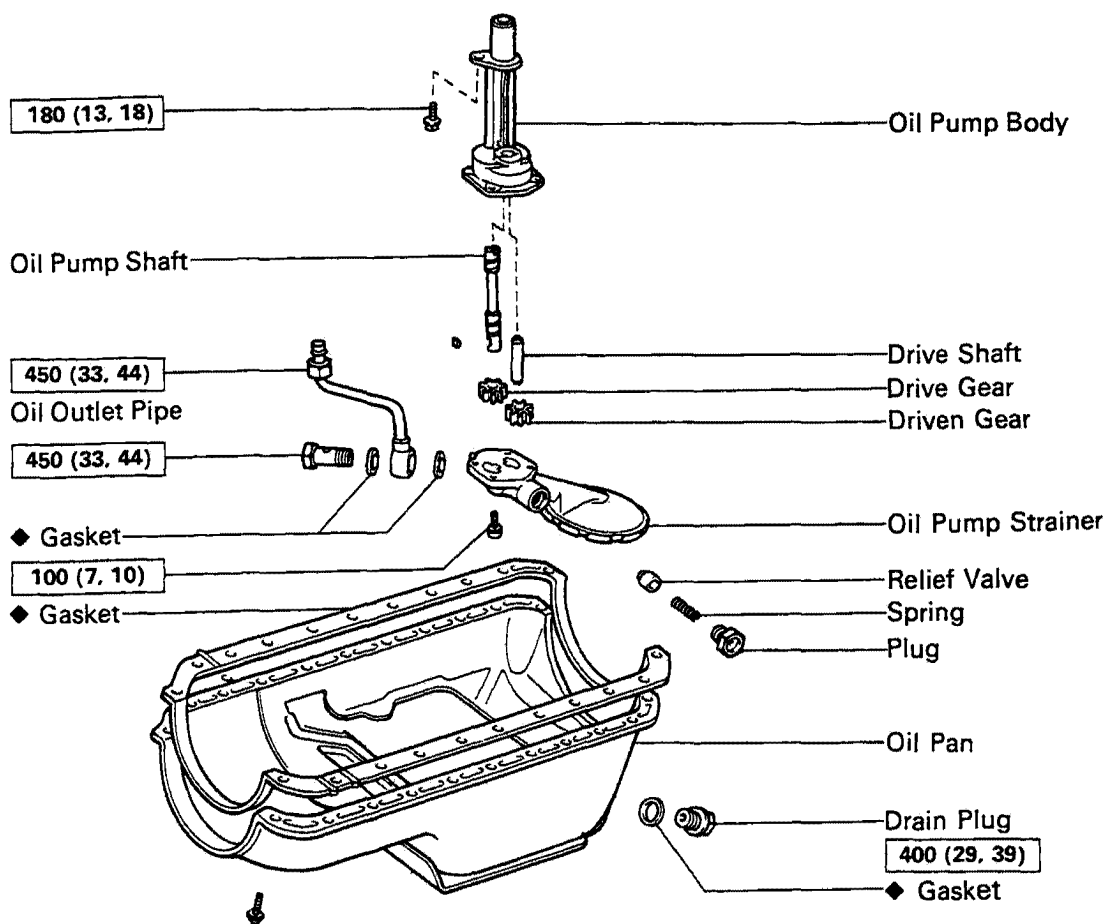
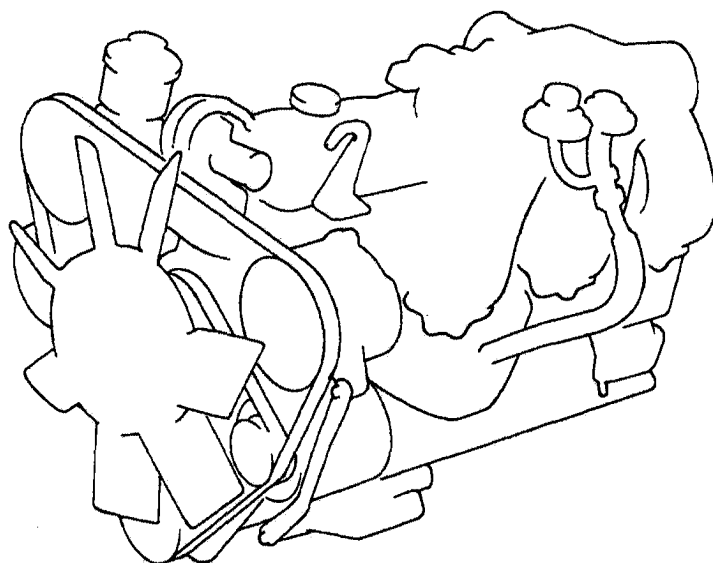

**Kg-cm (ft-lb, N-m)** : Specified torque

◆ Non-reusable part

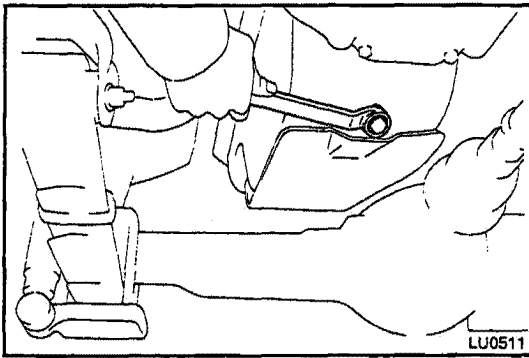

## REMOVAL OF OIL PUMP

(See page LU-5)

### 1. RAISE VEHICLE

**CAUTION:** Be sure the vehicle is securely supported.

### 2. DRAIN ENGINE OIL

(a) Remove the oil filler cap.

(b) Remove the oil drain plug and drain the oil into a container.

### 3. REMOVE OIL PAN

Remove the twenty-two bolts, oil pan and gasket.

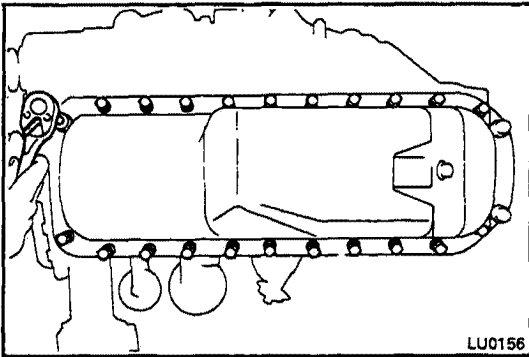

### 4. REMOVE OIL OUTLET PIPE

Remove the union nut, bolt, two gaskets and outlet pipe.

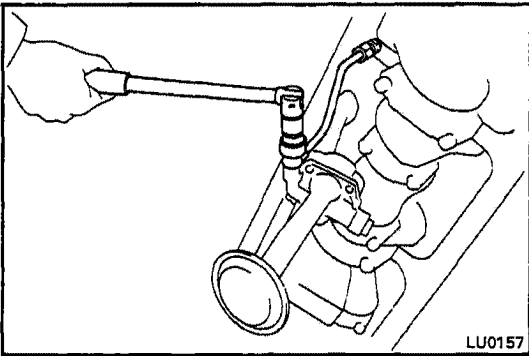

### 5. REMOVE OIL PUMP

Remove the bolt and oil pump.

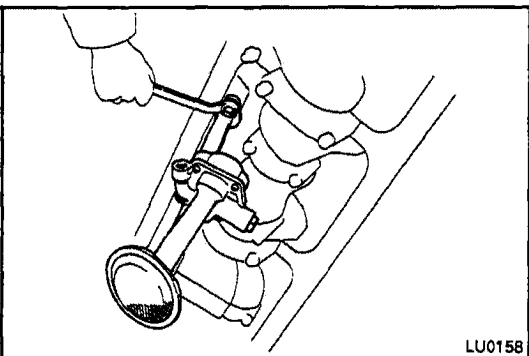

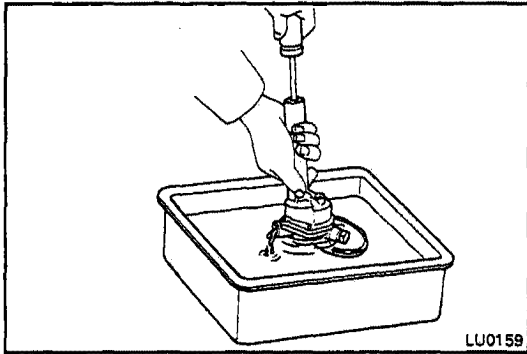

## OPERATION CHECK OF OIL PUMP

### CHECK PUMP OPERATION

- (a) Using a screwdriver, immerse the oil strainer into clean engine oil and turn the oil pump shaft clockwise. Oil should come out of the oil outlet hole.

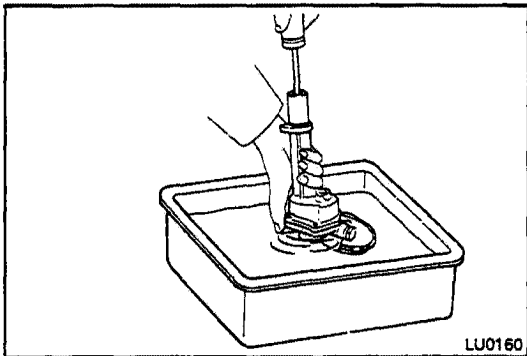

- (b) Close the oil outlet hole with your thumb, and turn the shaft as before. The shaft should be difficult to turn.

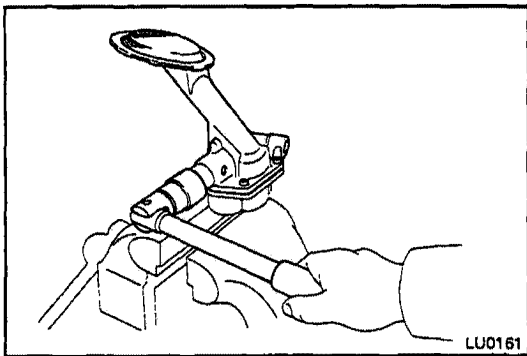

## DISASSEMBLY OF OIL PUMP

(See page LU-5)

1. **MOUNT OIL PUMP IN VISE**
2. **REMOVE RELIEF VALVE**  
Remove the plug, spring and relief valve.
3. **REMOVE OIL PUMP STRAINER**  
Remove the four screws and oil pump strainer.
4. **REMOVE DRIVEN GEAR**
5. **REMOVE DRIVE GEAR AND OIL PUMP SHAFT ASSEMBLY**

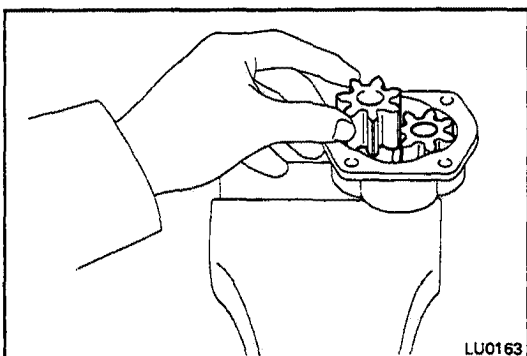
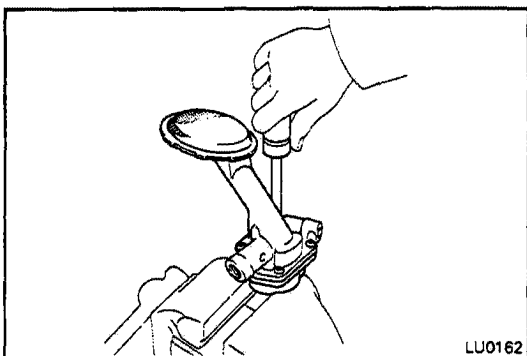

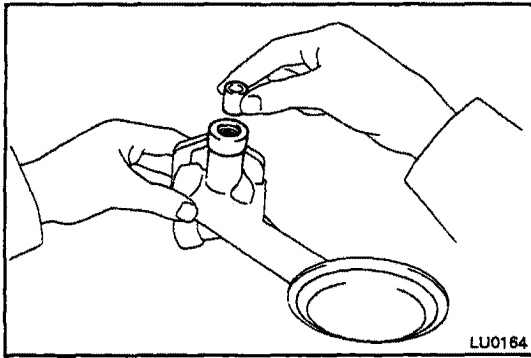

## INSPECTION OF OIL PUMP

### 1. INSPECT RELIEF VALVE

Coat the valve with engine oil and check that it falls smoothly into the valve hole by its own weight.

If it is not, replace the relief valve. If necessary, replace the oil pump assembly.

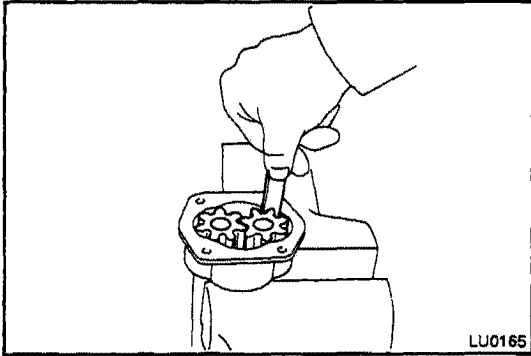

### 2. INSPECT DRIVE AND DRIVEN GEARS

#### A. Inspect gear body clearance

Using a thickness gauge, measure the clearance between the gear and pump body.

**Standard body clearance:** 0.095 – 0.175 mm  
(0.0037 – 0.0069 in.)

**Maximum body clearance:** 0.20 mm (0.0079 in.)

If the clearance is greater than maximum, replace the gears or oil pump assembly.

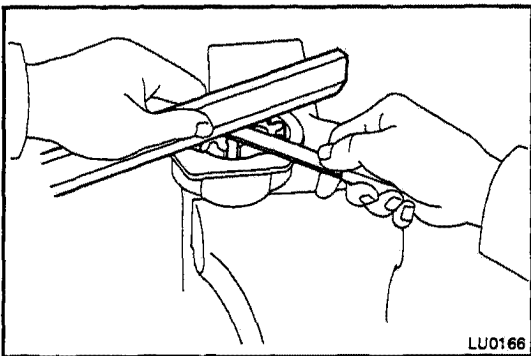

#### B. Inspect gear side clearance

Using a thickness gauge and precision straight edge, measure the clearance between the gear and precision straight edge.

**Standard side clearance:** 0.030 – 0.090 mm  
(0.0012 – 0.0035 in.)

**Maximum side clearance:** 0.15 mm (0.0059 in.)

If the clearance is greater than maximum, replace the gears. If necessary, the oil pump assembly.

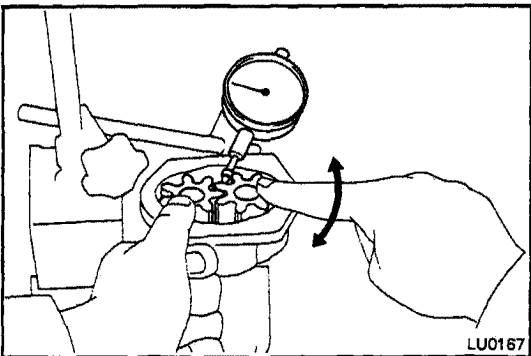

#### C. Inspect gear backlash

Using a dial indicator, measure the backlash while turning the driven gear clockwise and counterclockwise in several places.

**Standard backlash:** 0.500 – 0.600 mm  
(0.0197 – 0.0236 in.)

**Maximum backlash:** 0.95 mm (0.0374 in.)

If the backlash is greater than maximum, replace the gears. If necessary, replace the shaft.

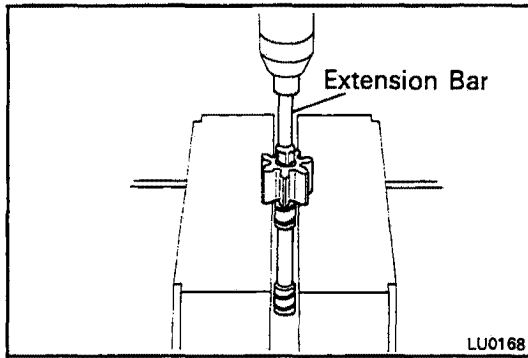

## REPLACEMENT OF OIL PUMP COMPONENTS

### 1. REPLACE DRIVE GEAR (OR OIL PUMP SHAFT)

(a) Using an extension bar and press, press out the oil pump shaft from the drive gear.

(b) Align the drive gear set key with the key groove of a new drive gear.

(c) Using a press, press in the oil pump shaft until it is 0.5 mm (0.020 in.) from the drive gear edge.

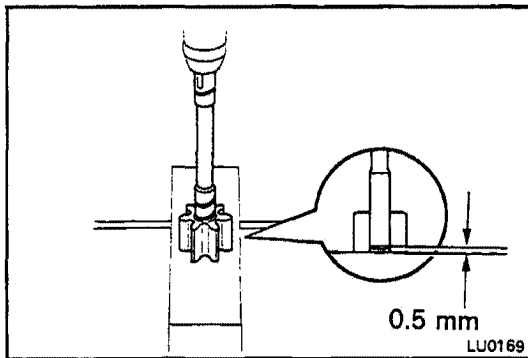

### 2. REPLACE DRIVEN SHAFT

(a) Using an extension bar and press, press out the driven shaft from the oil pump body.

(b) Using a press, press in a new driven shaft until it is 0.5 mm (0.020 in.) from the oil pump body edge.

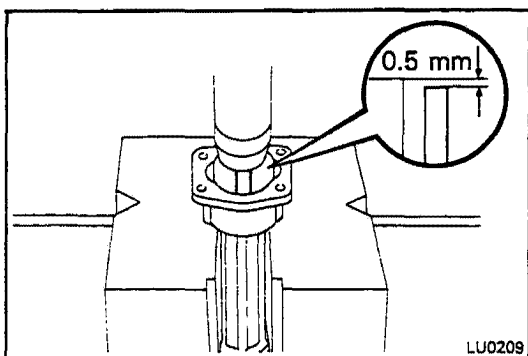
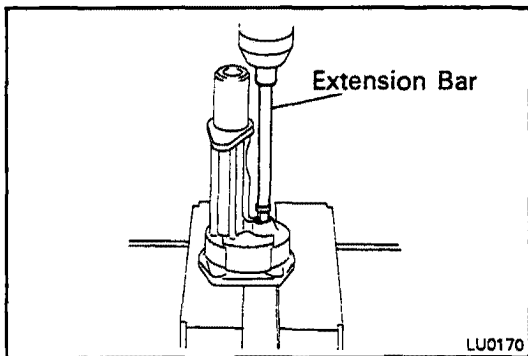

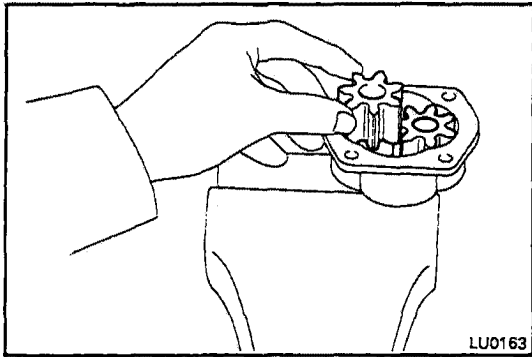

## ASSEMBLY OF OIL PUMP

(See page LU-5)

1. MOUNT OIL PUMP BODY IN VISE
2. INSTALL DRIVE GEAR AND OIL PUMP SHAFT ASSEMBLY
3. INSTALL DRIVEN GEAR

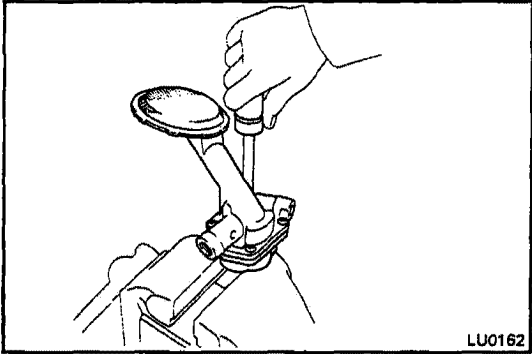

4. INSTALL OIL PUMP STRAINER

Install the oil pump strainer with the four screws.

Torque the screws.

Torque: 100 kg-cm (7 ft-lb, 10 N·m)

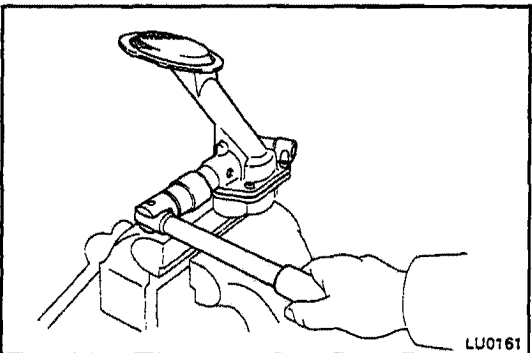

5. INSTALL RELIEF VALVE

Install the relief valve and spring with the relief valve plug. Torque the plug.

Torque: 375 kg-cm (27 ft-lb, 37 N·m)

6. CHECK OIL PUMP OPERATION  
(See page LU-7)

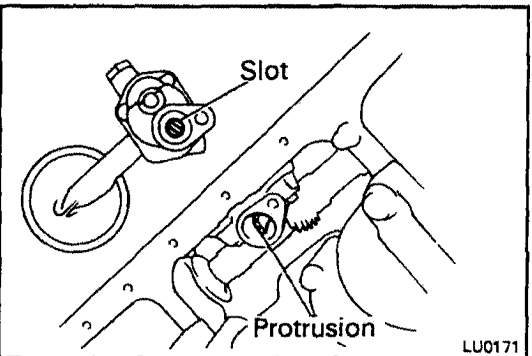

## INSTALLATION OF OIL PUMP

(See page LU-5)

1. INSTALL OIL PUMP

(a) Align the oil pump shaft slot of the oil pump with the governor shaft protrusion of the distributor.

(b) Install the oil pump with the bolt. Torque the bolt.

Torque: 180 kg-cm (13 ft-lb, 18 N·m)

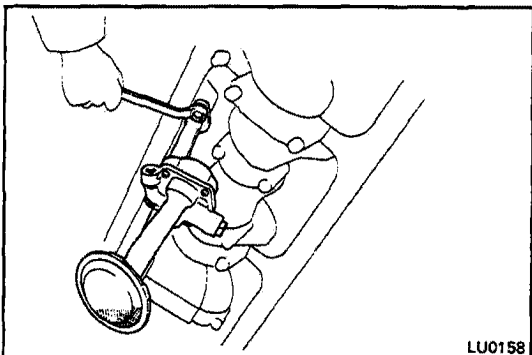

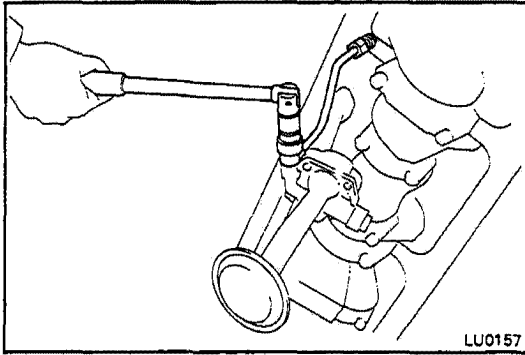

## 2. INSTALL OIL OUTLET PIPE

- (a) Place the outlet pipe in position.
- (b) Install and torque the union bolt with new two gaskets.

**Torque: 450 kg-cm (33 ft-lb, 44 N·m)**

- (c) Install and torque the union nut.

**Torque: 450 kg-cm (33 ft-lb, 44 N·m)**

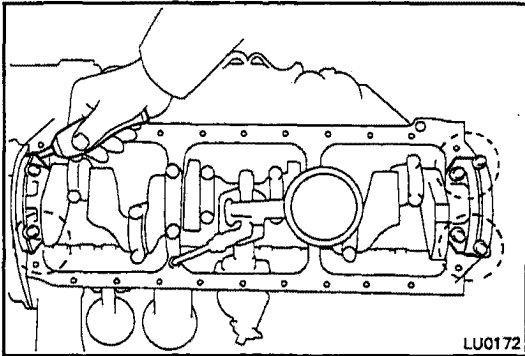

## 3. INSTALL OIL PAN

- (a) Apply seal packing to the cylinder block, the No. 1 and No. 4 main bearing caps as shown.

**Seal packing: Part No. 08826-00080 or equivalent**

- (b) Install a new gasket and the oil pan with the twenty-two bolts.

**Torque: 80 kg-cm (69 in.-lb, 7.8 N·m)**

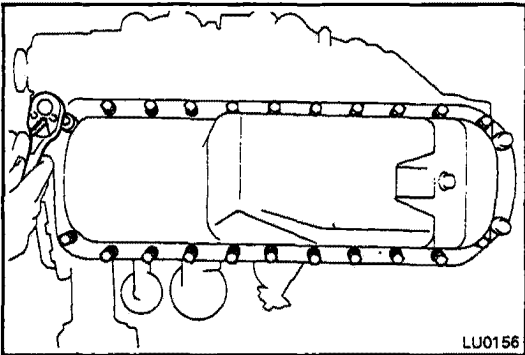

## 4. FILL WITH ENGINE OIL (See step 3 on page LU-4)

## 5. START ENGINE AND CHECK FOR LEAKS

## 6. RECHECK OIL LEVEL

Recheck the engine oil level and refill if necessary.

# OIL COOLER AND OIL RELIEF VALVE COMPONENTS

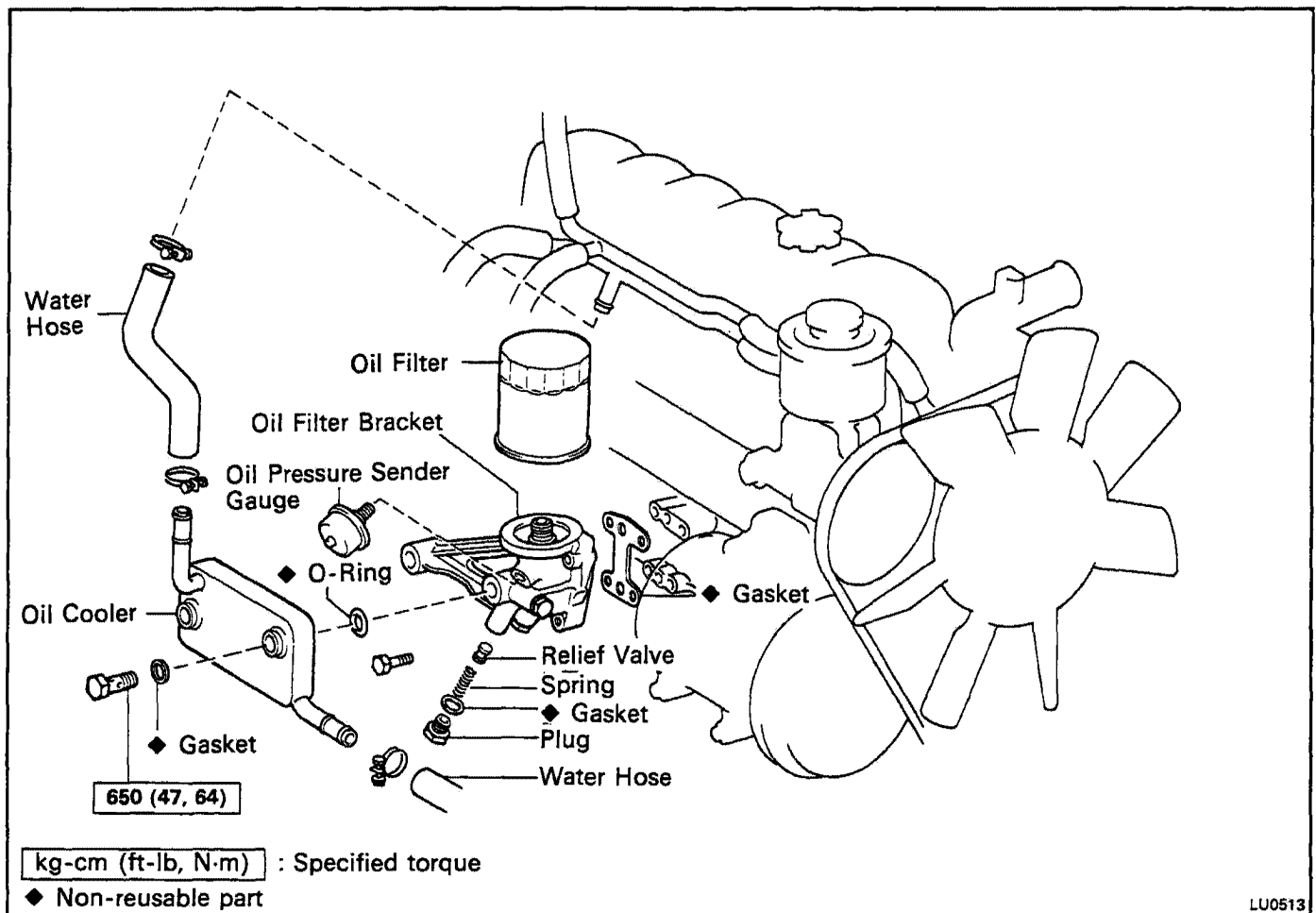

## REMOVAL OF OIL COOLER AND RELIEF VALVE

1. DRAIN ENGINE COOLANT (See page CO-3)
2. REMOVE AIR CLEANER HOSE
3. REMOVE OIL FILTER (See page LU-4)
4. REMOVE OIL PRESSURE SENDER GAUGE
5. DISCONNECT OIL COOLER HOSES

### 6. REMOVE OIL COOLER

Remove the two union bolts, gaskets, oil cooler and O-rings.

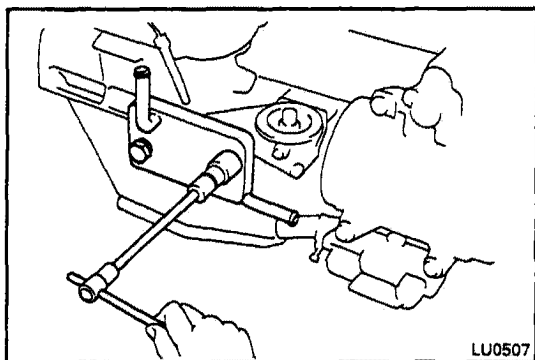

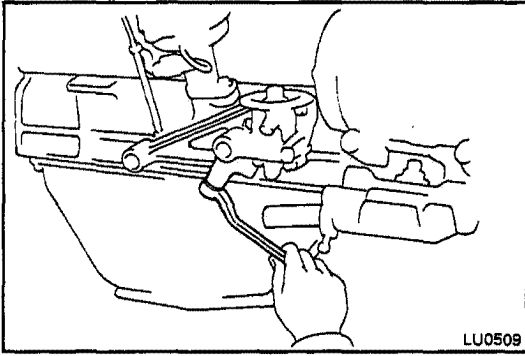
**7. REMOVE RELIEF VALVE**

Remove the plug, gasket, spring and relief valve.

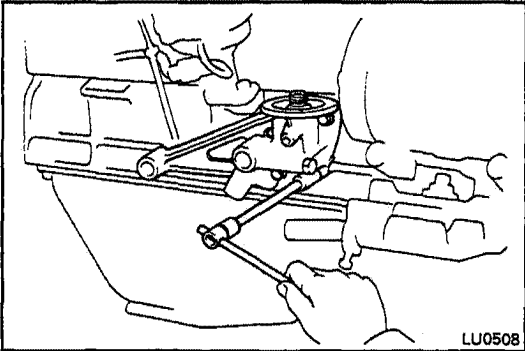
**8. REMOVE OIL FILTER BRACKET**

Remove the four bolts, oil filter bracket and gasket.

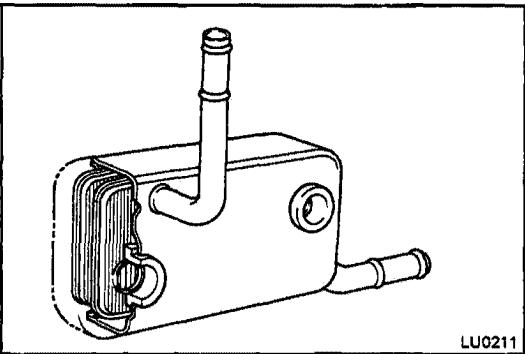
**INSPECTION OF OIL COOLER AND RELIEF VALVE****1. INSPECT OIL COOLER**

Check the oil cooler for damage or clogging.

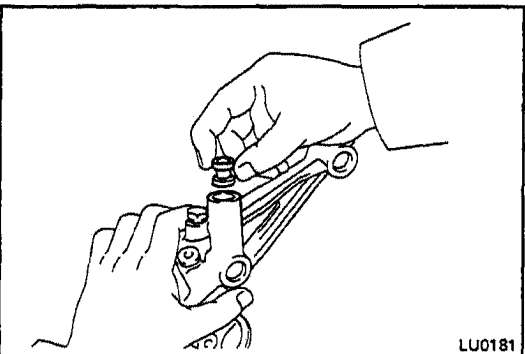
**2. INSPECT RELIEF VALVE**

Coat the valve with engine oil and check that it falls smoothly into the valve hole by its own weight.

If operation is not as specified, replace the relief valve. If necessary, replace the oil filter bracket.



## TROUBLESHOOTING

Problem	Possible cause	Remedy	Page
Engine will not start/ hard to start (cranks ok)	Incorrect ignition timing Ignition problems <ul style="list-style-type: none"> <li>● Ignition coil</li> <li>● Igniter</li> <li>● Distributor</li> <li>● High-tension cords</li> </ul> Ignition wiring disconnected or broken	Reset timing  Inspect coil Inspect igniter Inspect distributor Inspect high-tension cords  Inspect wiring	IG-11  IG-7 IG-7 IG-7 IG-6
Rough idle or stalls	Spark plugs faulty Ignition wiring faulty Incorrect ignition timing Ignition problems <ul style="list-style-type: none"> <li>● Ignition coil</li> <li>● Igniter</li> <li>● Distributor</li> <li>● High-tension cords</li> </ul>	Inspect plugs  Inspect wiring  Reset timing  Inspect coil Inspect igniter Inspect distributor Inspect high-tension cords	IG-6   IG-11  IG-7 IG-7 IG-7 IG-6
Engine hesitates/ poor acceleration	Spark plugs faulty Ignition wiring faulty Incorrect ignition timing	Inspect plugs  Inspect wiring  Reset timing	IG-6   IG-11
Engine dieseling (runs after ignition switch is turned off)	Incorrect ignition timing	Reset timing	IG-11
Muffler explosion (after fire) all the time	Incorrect ignition timing	Reset timing	IG-11
Engine backfires	Incorrect ignition timing	Reset timing	IG-11
Poor gasoline mileage	Spark plugs faulty Incorrect ignition timing	Inspect plugs  Reset timing	IG-6  IG-11
Engine overheats	Incorrect ignition timing	Reset timing	IG-11



# ON-VEHICLE INSPECTION

## SPARK TEST

### CHECK THAT SPARK OCCURS

- Disconnect high-tension cord from distributor.
- Hold the end approx. 12.5 mm (0.50 in.) from body of vehicle.
- See if spark occurs while engine is being cranked.

NOTE: To prevent gasoline from being injected from injectors during this test, crank the engine for no more than 1-2 seconds at a time.

If the spark does not occur, perform the test as follows:

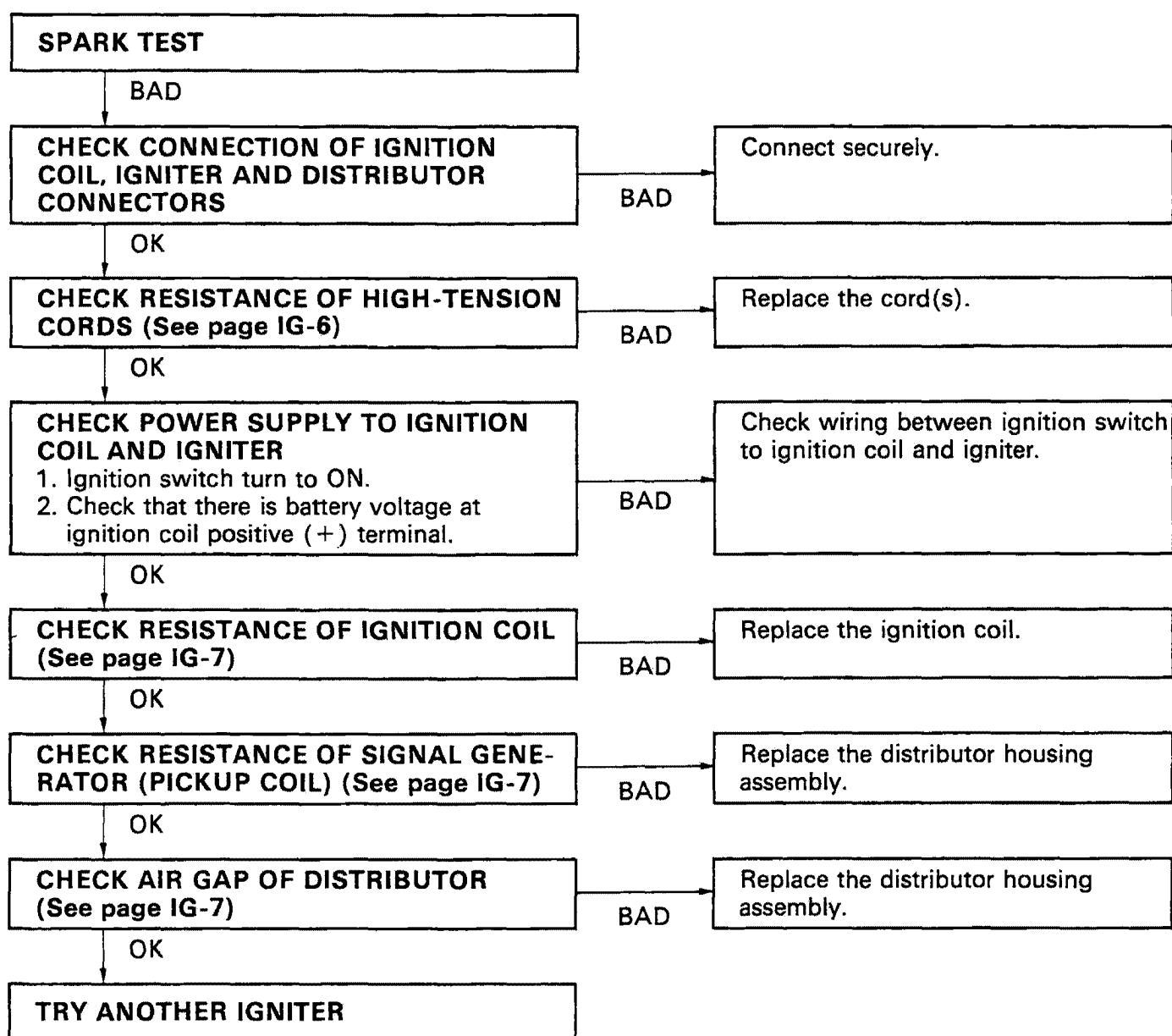

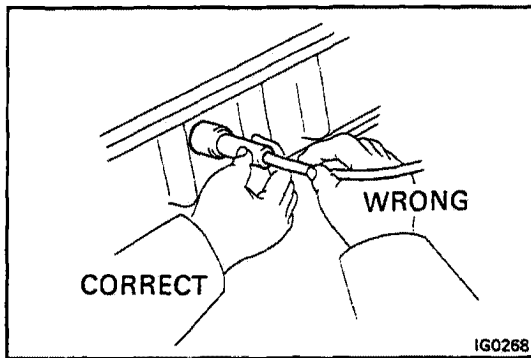

## INSPECTION OF HIGH-TENSION CORDS

1. **CAREFULLY REMOVE HIGH-TENSION CORDS BY THEIR RUBBER BOOTS FROM SPARK PLUGS**  
**CAUTION:** Pulling on or bending the cords may damage the conductor inside.

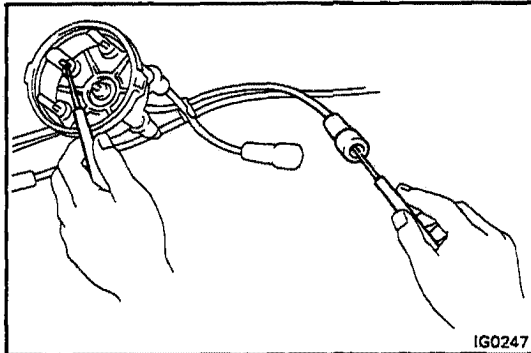

2. **INSPECT HIGH-TENSION CORD RESISTANCE**

Using an ohmmeter, measure the resistance without disconnecting the distributor cap.

**Maximum resistance: 25 kΩ per cord**

If resistance is greater than maximum, check the terminals. If necessary, replace the high-tension cord and/or distributor cap.

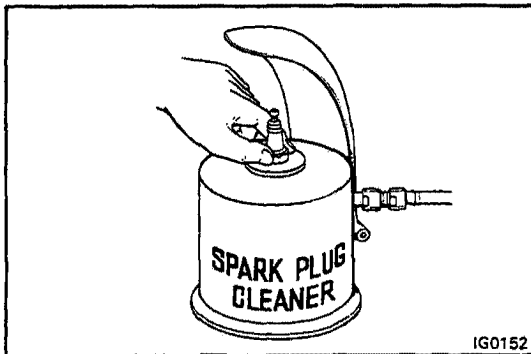

## INSPECTION OF SPARK PLUGS

1. **REMOVE SPARK PLUGS**
2. **CLEAN SPARK PLUGS**

Using a spark plug cleaner or wire brush, clean the spark plug.

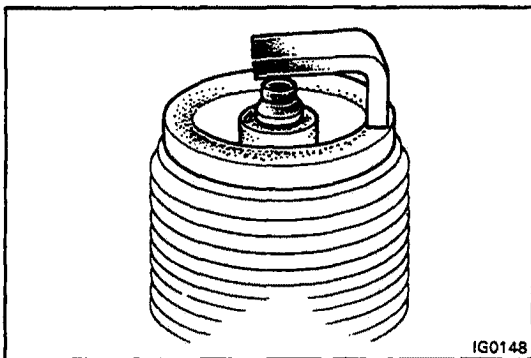

3. **VISUALLY INSPECT SPARK PLUGS**

Check the spark plug for electrode wear, thread damage and insulator damage.

If abnormal, replace the plugs.

**Recommended spark plugs:** ND W16EXR-U  
 NGK BPR5EY

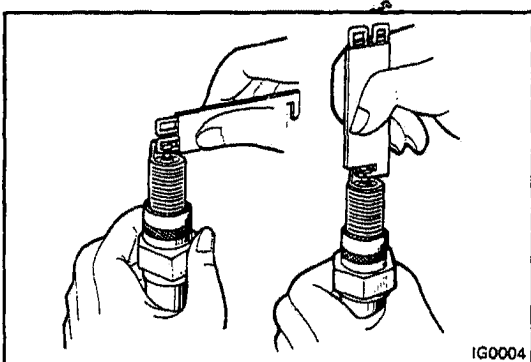

4. **ADJUST ELECTRODE GAP**

Carefully bend the outer electrode to obtain the correct electrode gap.

**Correct electrode gap: 0.8 mm (0.031 in.)**

5. **INSTALL SPARK PLUGS**

**Torque: 180 kg-cm (13 ft-lb, 18 N·m)**

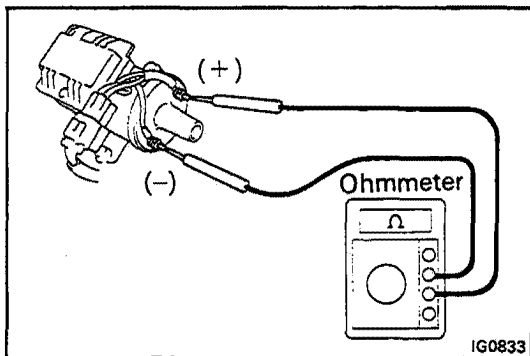

### INSPECTION OF IGNITION COIL

**1. DISCONNECT HIGH-TENSION CORD**

**2. INSPECT PRIMARY COIL RESISTANCE**

Using an ohmmeter, measure the resistance between the positive (+) and negative (-) terminals.

**Primary coil resistance (cold): 0.52 – 0.64 Ω**

If the resistance is not as specified, replace the ignition coil.

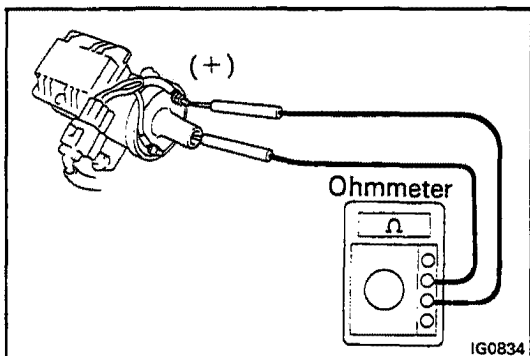

**3. INSPECT SECONDARY COIL RESISTANCE**

Using an ohmmeter, measure the resistance between the positive (+) terminal and high-tension terminal.

**Secondary coil resistance (Cold): 11.5 – 15.5 kΩ**

If the resistance is not as specified, replace the ignition coil.

**4. RECONNECT HIGH-TENSION CORD**

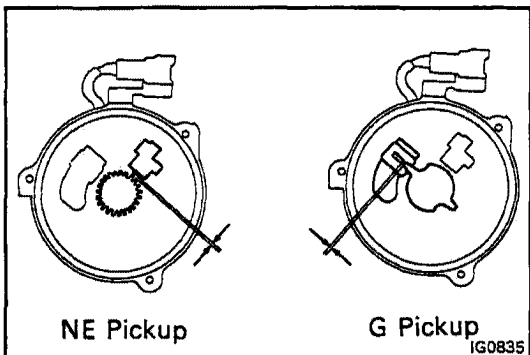

### INSPECTION OF DISTRIBUTOR

**1. INSPECT AIR GAP**

Using a thickness gauge, measure the gap between the signal rotor and pickup coil projection.

**Air gap: 0.2 mm (0.008 in.) or more**

If the gap is not as specified, replace the distributor.

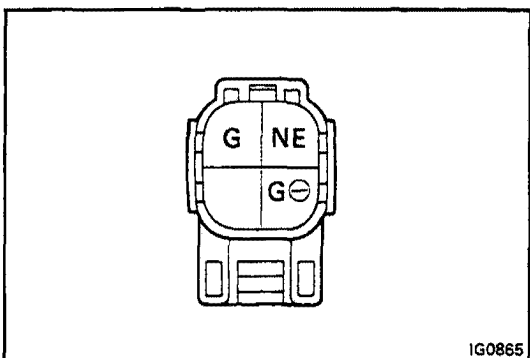

**2. INSPECT PICKUP COIL RESISTANCE**

Using an ohmmeter, measure the resistance between the terminals.

**G pickup coil resistance (G – G⊖):  
140 – 180 Ω**

**NE pickup coil resistance (NE – G⊖):  
140 – 180 Ω**

If the resistance is not as specified, replace the distributor.

### INSPECTION OF IGNITER

(See procedure Spark Test on page IG-5)

## DISTRIBUTOR COMPONENTS

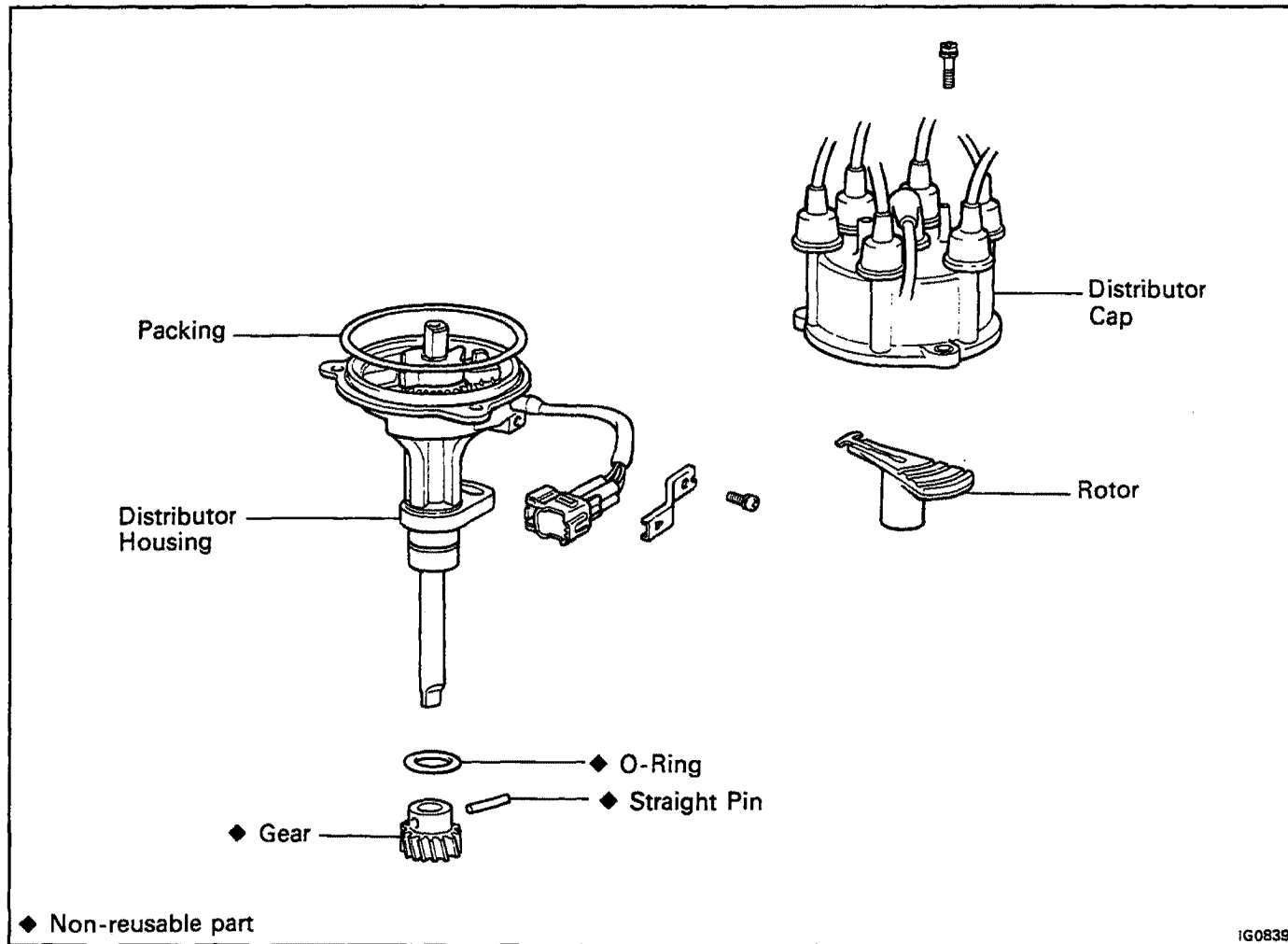

### REMOVAL OF DISTRIBUTOR

1. REMOVE AIR CLEANER HOSE
2. DISCONNECT DISTRIBUTOR CONNECTOR
3. DISCONNECT VENTILATION HOSES
4. DISCONNECT HIGH-TENSION CORDS FROM SPARK PLUGS AND IGNITION COIL
5. REMOVE DISTRIBUTOR  
Remove the mount bolt and pull out the distributor.
6. REMOVE O-RING FROM DISTRIBUTOR HOUSING

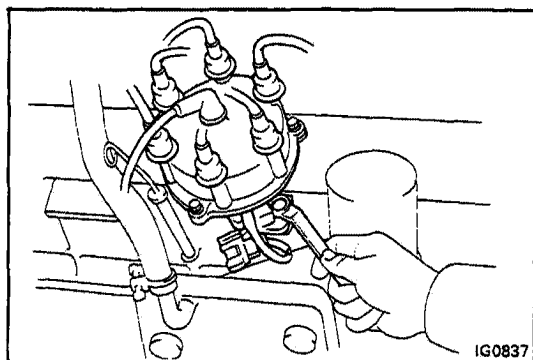

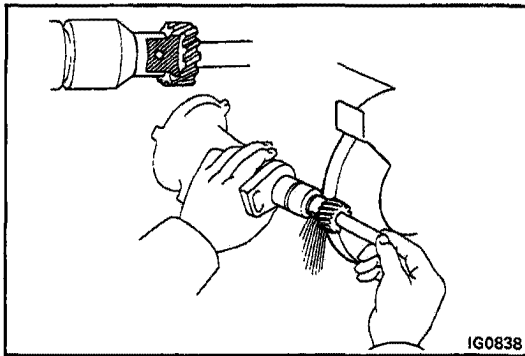

## REPLACEMENT OF DISTRIBUTOR DRIVEN GEAR

### 1. REMOVE DRIVEN GEAR

- (a) Using a grinder, grind the driven gear and straight pin.

**CAUTION:** Be careful not to damage the governor shaft.

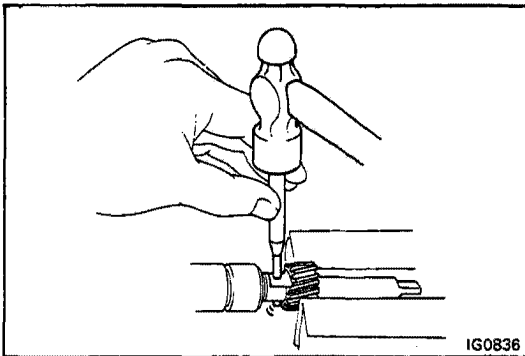

- (b) Mount the driven gear in a vice.  
 (c) Using a pin punch and hammer, tap out the straight pin.  
 (d) Remove the driven gear.

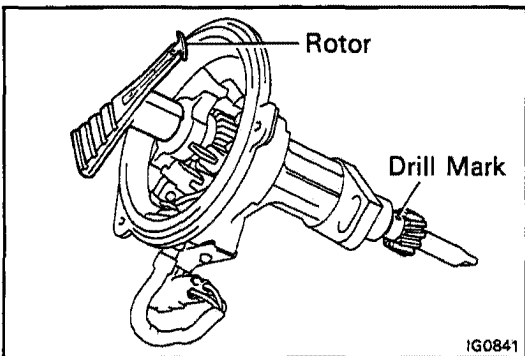

### 2. INSTALL NEW DRIVEN GEAR

- (a) Slide a new driven gear onto the governor shaft.  
 (b) Position the drill mark on the driven gear and rotor as shown.

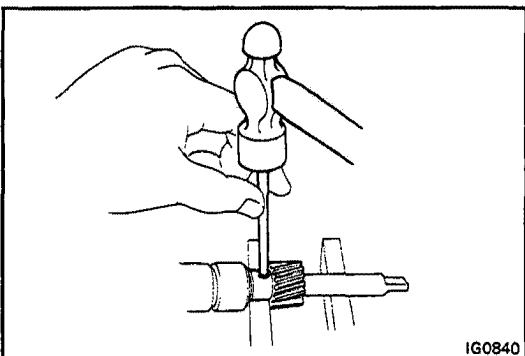

- (c) Install a new straight pin.  
 (d) Secure the ends of the straight pin.

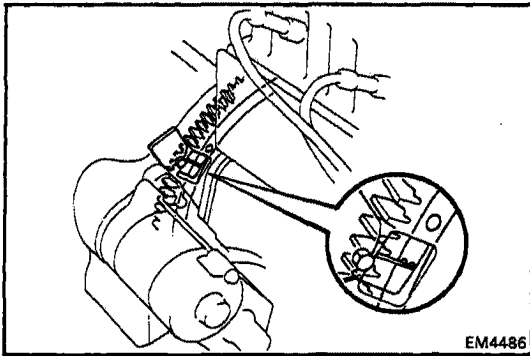

EM4486

## INSTALLATION OF DISTRIBUTOR

### 1. SET NO. 1 CYLINDER TO TDC/COMPRESSION

Set to TDC/compression in the following manner.

- Remove the No. 1 spark plug.
- Place your finger over the hole of the No. 1 spark plug and turn the crankshaft clockwise to TDC/compression. If pressure is felt on your finger, this is TDC/compression. If not, repeat the process.
- Install the No. 1 spark plug.

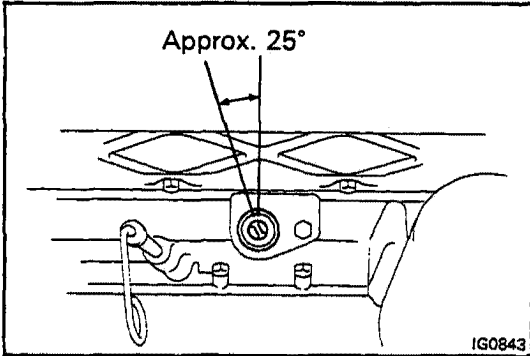

IG0843

### 2. SET OIL PUMP SHAFT SLOT

Position the oil pump shaft slot in the direction shown in the figure.

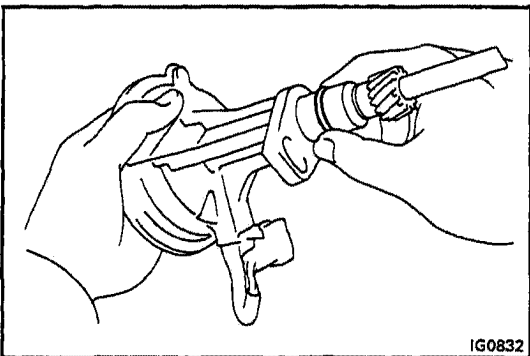

IG0832

### 3. INSTALL NEW O-RING

- (a) Install a new O-ring to the housing.
- (b) Apply a light coat of engine oil on the O-ring.

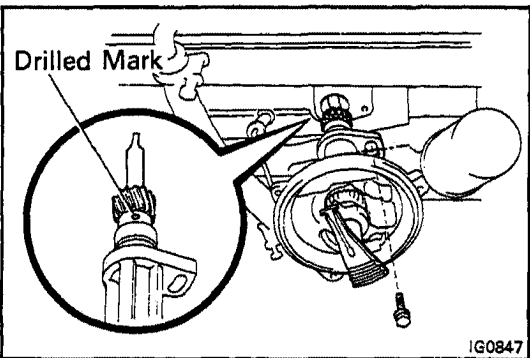

IG0847

### 4. INSTALL DISTRIBUTOR

- (a) Insert the distributor, aligning the center of the flange with that of the bolt hole on the cylinder head with drilled mark facing upward.

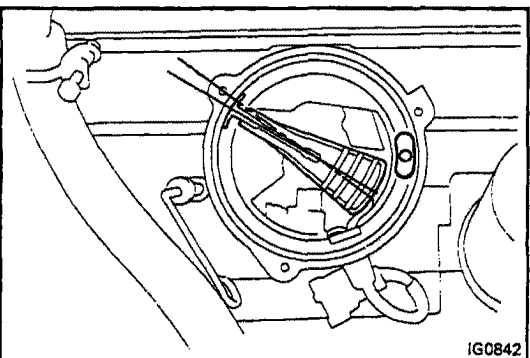

IG0842

- (b) When fully installed, the distributor should point as shown in the figure.
- (c) Lightly tighten the hold-down bolt.

5. **INSTALL DISTRIBUTOR CAP WITH HIGH-TENSION CORDS**
6. **CONNECT HIGH-TENSION CORDS TO SPARK PLUGS**  
Firing order: 1 – 5 – 3 – 6 – 2 – 4
7. **CONNECT VENTILATION HOSES**
8. **CONNECT DISTRIBUTOR CONNECTOR**
9. **INSTALL AIR CLEANER HOSE**

10. **WARM UP ENGINE**

Allow the engine to reach normal operating temperature.

11. **CONNECT TACHOMETER AND TIMING LIGHT TO ENGINE**

Connect the tachometer test probe to terminal IG $\ominus$  of the check connector.

**CAUTION:**

- **EVER** allow the tachometer terminals to touch ground as it could result in damage to the igniter and/or ignition coil.
- As some tachometers are not compatible with this ignition system, we recommend that you confirm the compatibility of your until before using.

12. **ADJUST IGNITION TIMING**

- (a) Using a service wire, short terminals TE1 and E1 of the check connector.
- (b) Check the idle speed.

**Idle speed: 650 rpm**

- (c) Using a timing light, slowly turn the distributor until the timing mark on the drive plate is aligned with the 7° mark.

**Ignition timing: 7° BTDC @ idle**

- (d) Tighten the distributor bolt and recheck the ignition timing.

**Torque: 175 kg-cm (13 ft-lb, 17 N·m)**

- (e) Remove the service wire.

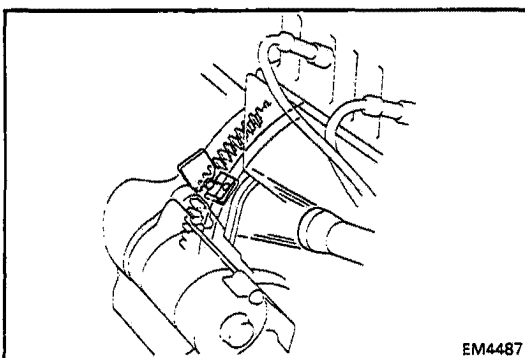
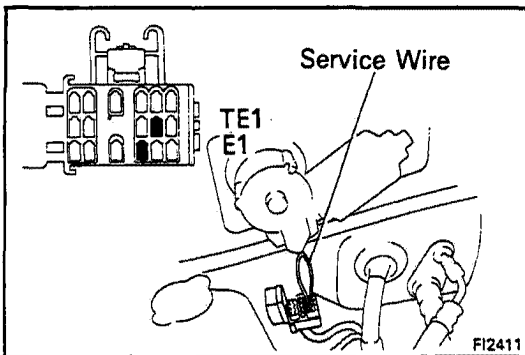
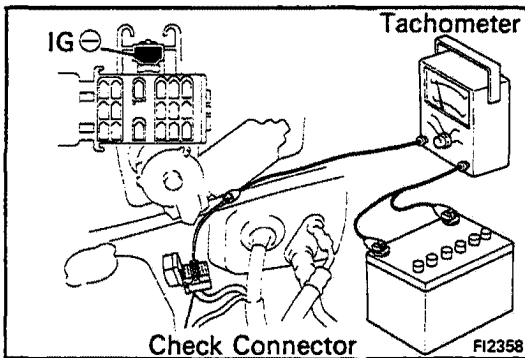

13. **FURTHER CHECK IGNITION TIMING**

**Ignition timing: 12° BTDC @ idle**

14. **DISCONNECT TACHOMETER AND TIMING LIGHT FROM ENGINE**



---

# STARTING SYSTEM

	Page
TROUBLESHOOTING .....	ST-2
STARTER .....	ST-3

**ST**

## TROUBLESHOOTING

Problem	Possible cause	Remedy	Page
Engine will not crank	Battery charge low	Check battery specific gravity Charge or replace battery	CH-3
	Battery cables loose, corroded or worn Neutral start switch faulty Fusible link blown Starter faulty Ignition switch faulty	Repair or replace cable Replace switch Replace fusible link Repair starter Replace ignition switch	ST-3
Engine cranks slowly	Battery charge low	Check battery specific gravity Charge or replace battery	CH-3
	Battery cables loose, corroded or worn Starter faulty	Repair or replace cables Repair starter	ST-3
Starter keeps running	Starter faulty	Repair starter	ST-3
	Ignition switch faulty	Replace ignition switch	
	Short in wiring	Repair wiring	
Starter spins but engine will not crank	Pinion gear teeth broken or faulty starter	Repair starter	ST-3
	Drive plate teeth broken	Replace Drive plate	

# STARTER COMPONENTS

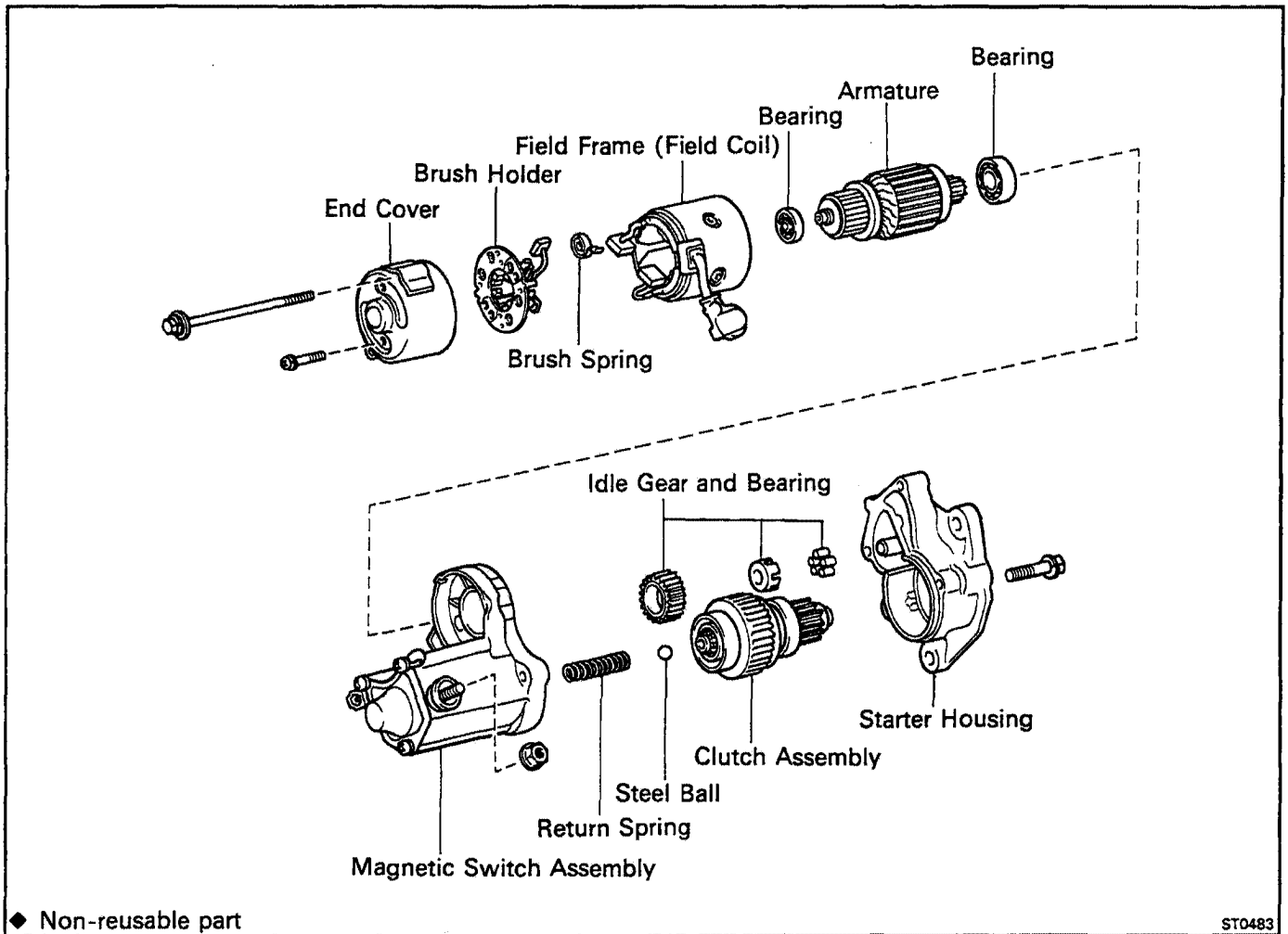

## REMOVAL OF STARTER

1. **DISCONNECT CABLE FROM NEGATIVE TERMINAL OF BATTERY**

2. **DISCONNECT CABLE AND CONNECTOR**

Remove the nut and disconnect the battery cable from the magnetic switch on the starter motor.

Disconnect the connector from terminal 50.

3. **REMOVE STARTER MOTOR**

- (a) Remove the bolt and disconnect the ground strap.
- (b) Remove the nut and starter motor.

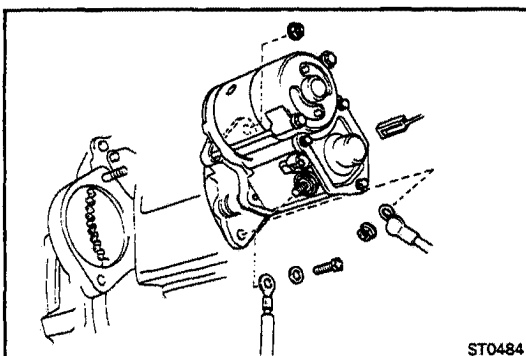

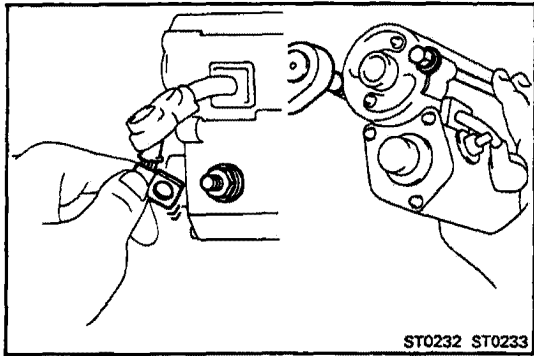

## DISASSEMBLY OF STARTER

(See page ST-3)

### 1. REMOVE FIELD FRAME WITH ARMATURE FROM MAGNETIC SWITCH ASSEMBLY

- (a) Remove the nut, and disconnect the lead wire from the magnetic switch terminal.
- (b) Remove the two through bolts.
- (c) Pull out the field frame with the armature from the magnetic switch assembly.

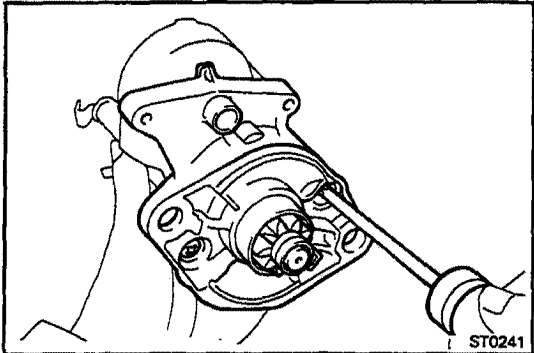

### 2. REMOVE STARTER HOUSING, CLUTCH ASSEMBLY AND IDLE GEAR

- (a) Remove the two screws.

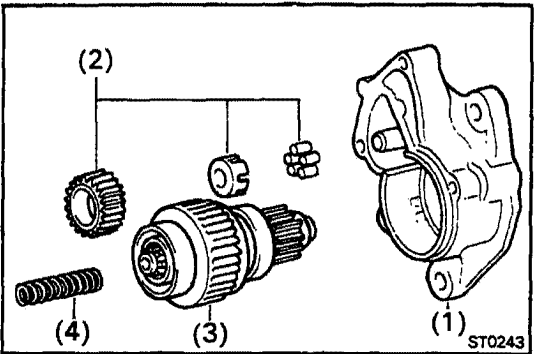

- (b) Remove the following parts from the magnetic switch assembly:

- (1) Starter housing
- (2) Idle gear and bearing
- (3) Clutch assembly
- (4) Return spring

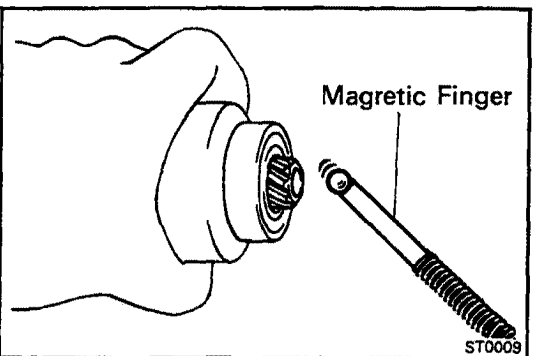

### 3. REMOVE STEEL BALL

Using a magnetic finger, remove the steel ball from the clutch shaft hole.

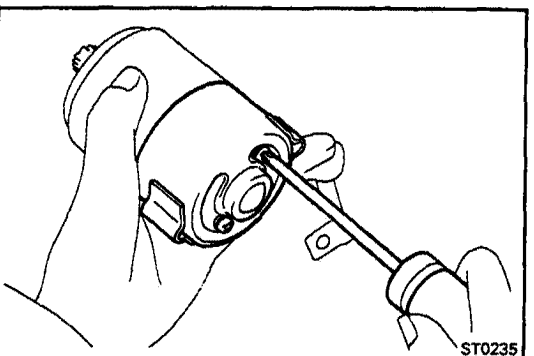

### 4. REMOVE BRUSH HOLDER

- (a) Remove the two screws and end cover from the field frame.

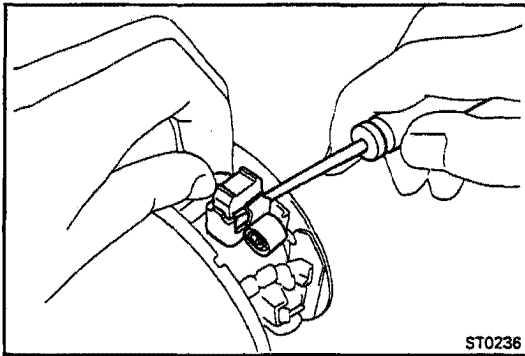

- (b) Using a screwdriver, hold the spring back and disconnect the brush from the brush holder. Disconnect the four brushes and remove the brush holder.

## 5. REMOVE ARMATURE FROM FIELD FRAME

## INSPECTION AND REPAIR OF STARTER

### Armature Coil

#### 1. INSPECT COMMUTATOR FOR OPEN CIRCUIT

Using an ohmmeter, check that there is continuity between the segments of the commutator.

If there is no continuity between any segment, replace the armature.

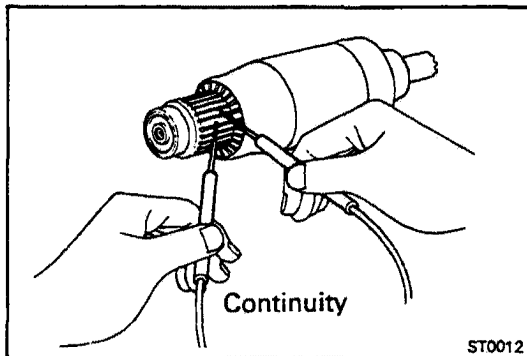

#### 2. INSPECT COMMUTATOR FOR GROUND

Using an ohmmeter, check that there is no continuity between the commutator and armature coil core.

If there is continuity, replace the armature.

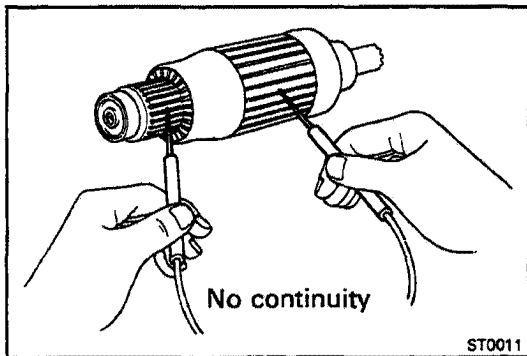

### Commutator

#### 1. INSPECT COMMUTATOR FOR DIRTY AND BURNT SURFACES

If the surface is dirty or burnt, correct it with sandpaper (No.400) or a lathe.

#### 2. INSPECT COMMUTATOR CIRCLE RUNOUT

(a) Place the commutator on V-blocks.

(b) Using a dial indicator, measure the circle runout.

**Maximum circle runout: 0.05 mm (0.0020 in.)**

If the circle runout is greater than maximum, correct it with a lathe.

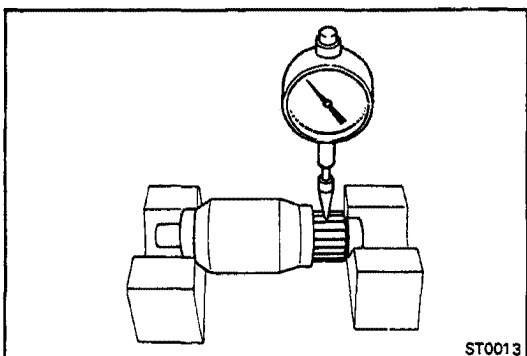

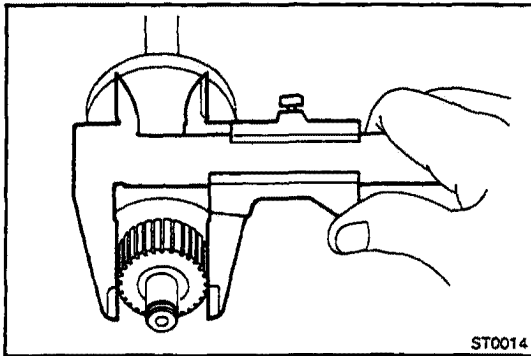

### 3. INSPECT COMMUTATOR DIAMETER

Using calipers, measure the commutator diameter.

**Standard diameter: 30 mm (1.18 in.)**

**Minimum diameter: 29 mm (1.14 in.)**

If the diameter is less than minimum, replace the armature.

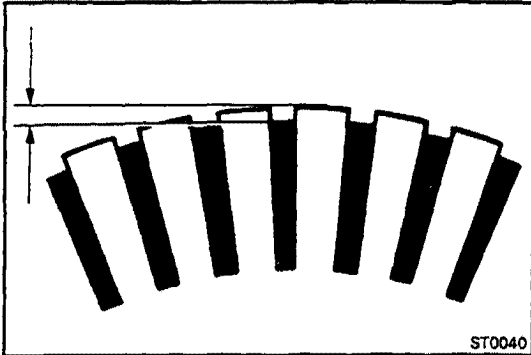

### 4. INSPECT UNDERCUT DEPTH

Check that the undercut depth is clean and free of foreign material. Smooth out the edge.

**Standard undercut depth: 0.6 mm (0.024 in.)**

**Minimum undercut depth: 0.2 mm (0.008 in.)**

If the undercut depth is less than minimum, correct it with a hacksaw blade.

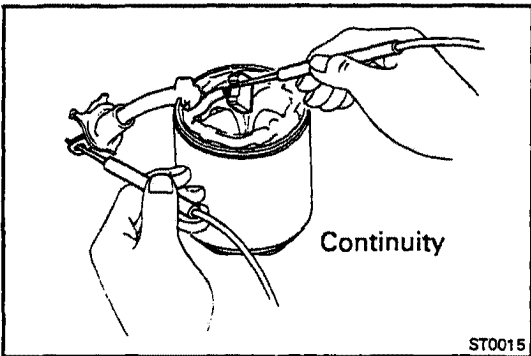

## Field Frame (Field Coil)

### 1. INSPECT FIELD COIL FOR OPEN CIRCUIT

Using an ohmmeter, check that there is continuity between the lead wire and field coil brush lead.

If there is no continuity, replace the field frame.

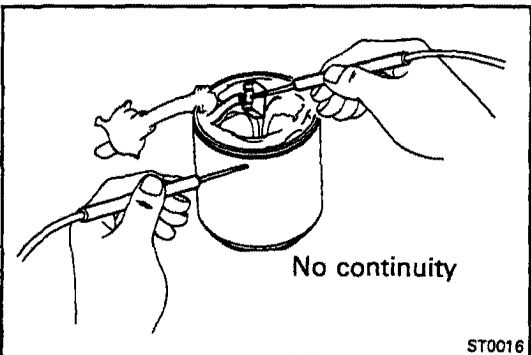

### 2. INSPECT FIELD COIL FOR GROUND

Using an ohmmeter, check that there is no continuity between the field coil end and field frame.

If there is continuity, repair or replace the field frame.

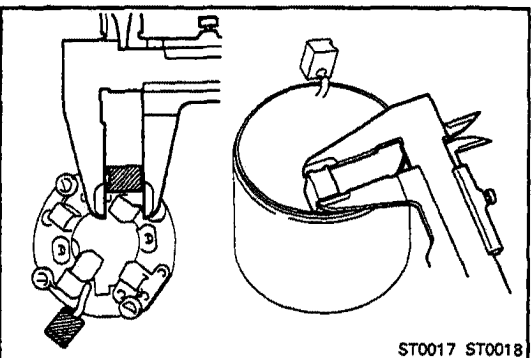

## Brushes

### INSPECT BRUSH LENGTH

Using calipers, measure the brush length.

**Standard length: 13.5 mm (0.531 in.)**

**Minimum length: 8.5 mm (0.335 in.)**

If the length is less than minimum, replace the brush holder and field frame.

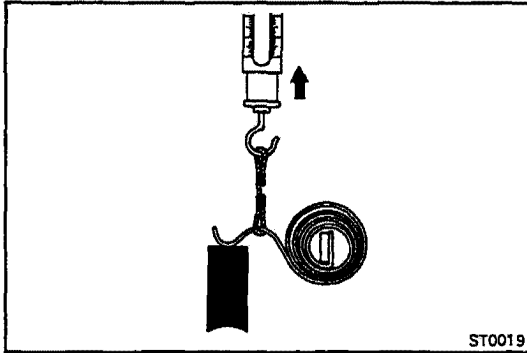

## Brush Springs

### INSPECT BRUSH SPRING LOAD

Take the pull scale reading the instant the brush spring separates from the brush.

**Spring installed load:**

**1.79 – 2.41 kg (3.9 – 5.3 lb, 18 – 24 N)**

If the installed load is not within specification, replace the brush springs.

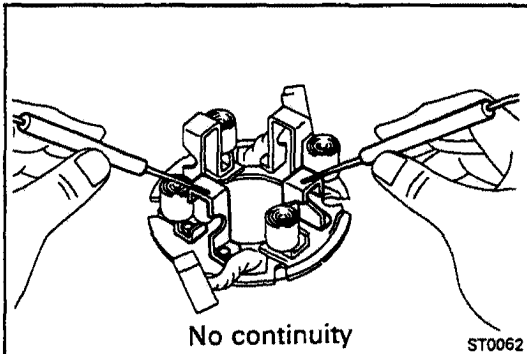

## Brush Holder

### INSPECT BRUSH HOLDER INSULATION

Using an ohmmeter, check that there is no continuity between the positive (+) and negative (-) brush holders.

If there is continuity, repair or replace the brush holder.

## Clutch and Gears

### 1. INSPECT GEAR TEETH

Check the gear teeth on the pinion gear, idler gear and clutch assembly for wear or damage.

If damaged, replace the gear or clutch assembly.

If damaged, also check the drive plate ring gear for wear or damage.

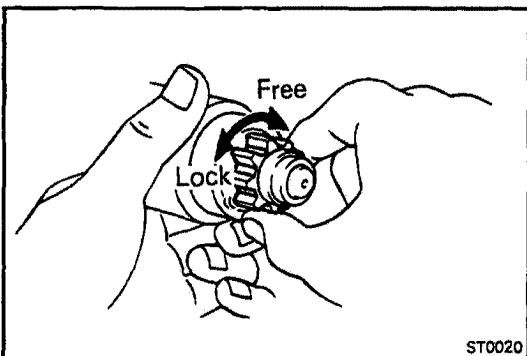

### 2. INSPECT CLUTCH

Rotate the clutch pinion gear clockwise and check that it turns freely. Try to rotate the clutch pinion gear counter-clockwise and check that it locks.

If necessary, replace the clutch assembly.

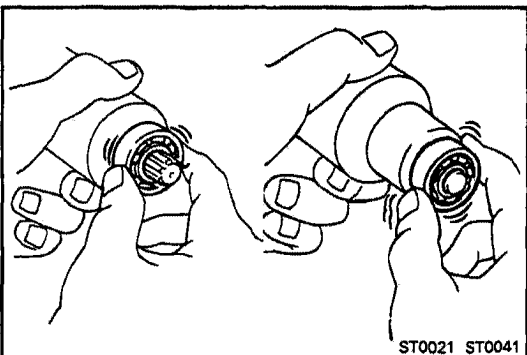

## Bearings

### 1. INSPECT BEARINGS

Turn each bearing by hand while applying inward force.

If resistance is felt or if the bearing sticks, replace the bearing.

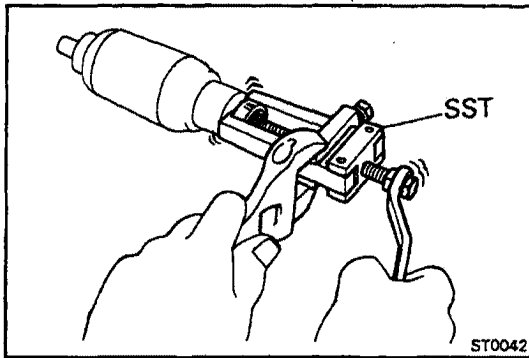

## 2. IF NECESSARY, REPLACE BEARINGS

(a) Using SST, remove the bearing.

SST 09286-46011

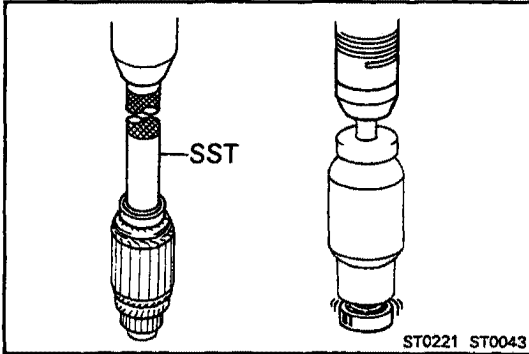

(b) Using SST and a press, press in a new front bearing.

SST 09285-76010

(c) Using a press, press in a new rear bearing.

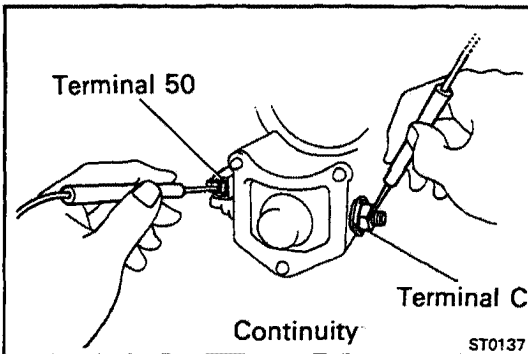

## Magnetic Switch

### 1. PERFORM PULL-IN COIL OPEN CIRCUIT TEST

Using an ohmmeter, check that there is continuity between terminals 50 and C.

If there is no continuity, replace the magnetic switch assembly.

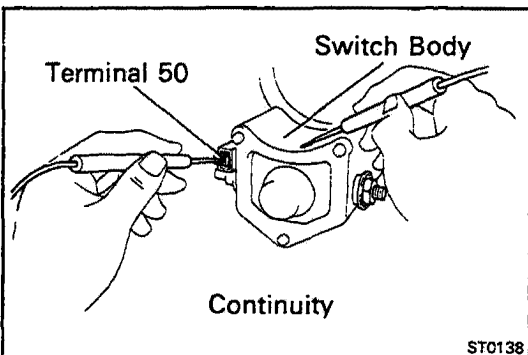

### 2. PERFORM HOLD-IN COIL OPEN CIRCUIT TEST

Using an ohmmeter, check that there is continuity between terminal 50 and the switch body.

If there is no continuity, replace the magnetic switch assembly.

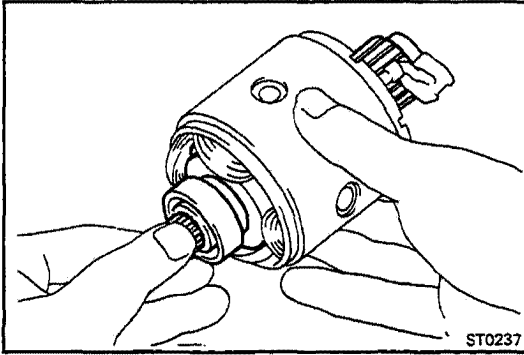

## ASSEMBLY OF STARTER

(See page ST-3)

NOTE: Use high-temperature grease to lubricate the bearings and gears when assembling the starter.

### 1. PLACE ARMATURE INTO FIELD FRAME

Apply grease to the armature bearings and insert the armature into the field frame.

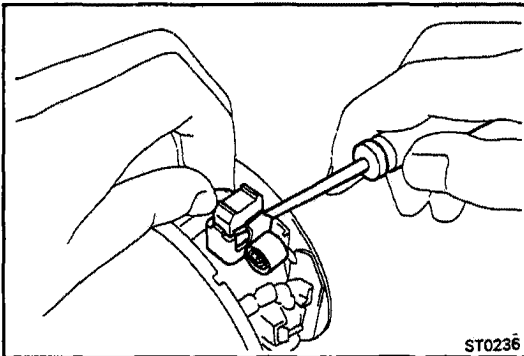

### 2. INSTALL BRUSH HOLDER

(a) Place the brush holder on the armature.

(b) Using a screwdriver, hold the brush spring back, and connect the brush into the brush holder. Connect the four brushes.

NOTE: Check that the positive (+) lead wires are not grounded.

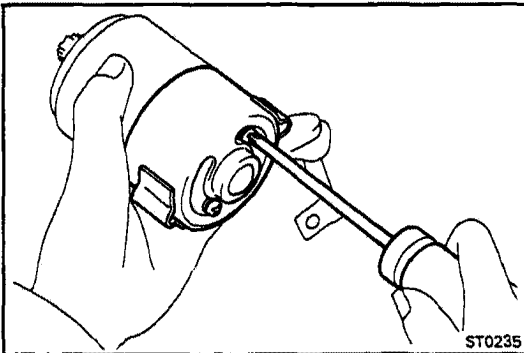

(c) Install the end cover to the field frame with the two screws.

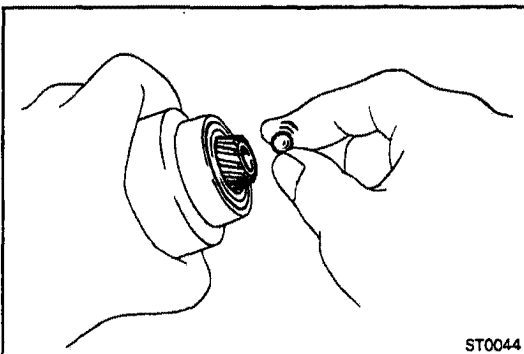

### 3. INSERT STEEL BALL INTO CLUTCH SHAFT HOLE

(a) Apply grease to the steel ball.

(b) Insert the steel ball into the clutch shaft hole.

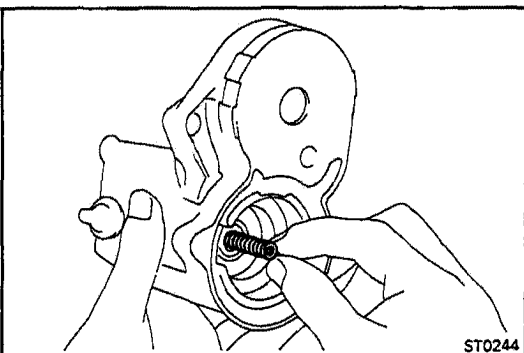

### 4. INSTALL CLUTCH ASSEMBLY, IDLE GEAR AND STARTER HOUSING

(a) Apply grease to the return spring, the clutch assembly, idle gear and bearing.

(b) Insert the return spring into the magnetic switch hole.

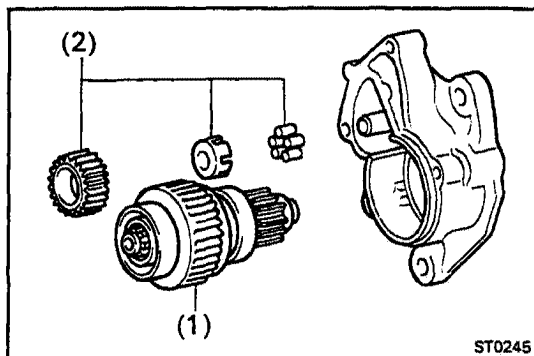

- (c) Place the following parts in position on the starter housing:
- (1) Clutch assembly
  - (2) Idler gear and bearing

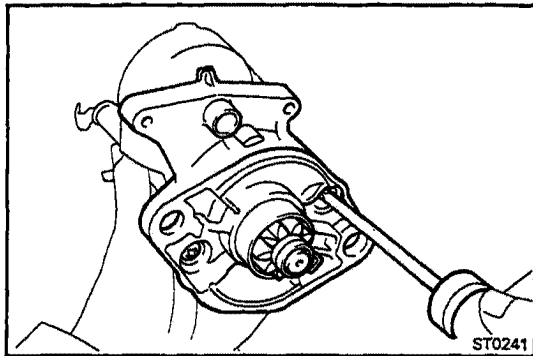

- (d) Assemble the starter housing and magnetic switch assembly and install the two screws.

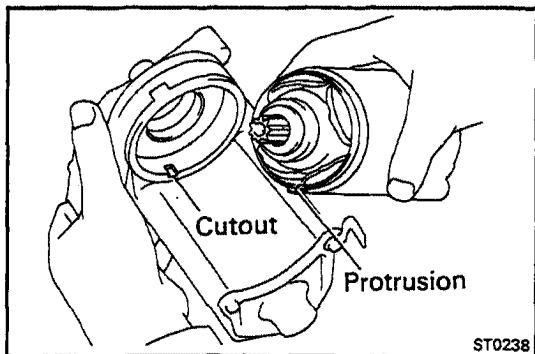

#### 5. INSTALL FIELD FRAME WITH ARMATURE TO MAGNETIC SWITCH ASSEMBLY

- (a) Align the protrusion of the field frame with the cutout of the magnetic switch assembly.

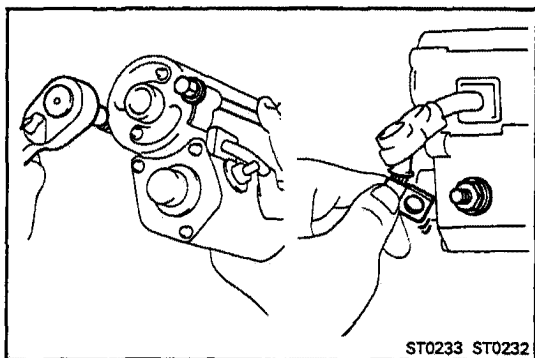

- (b) Install the two through bolts.
- (c) Connect the lead wire to the magnetic switch terminal C, and install the nut.

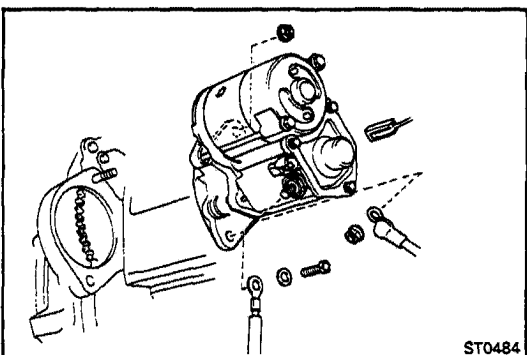
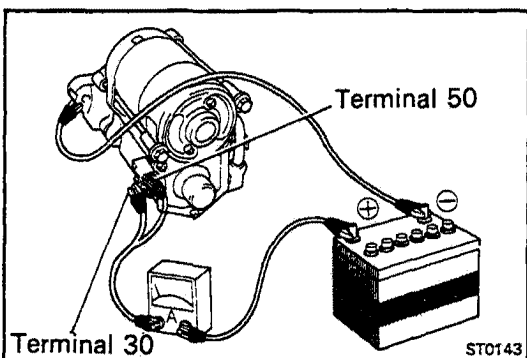
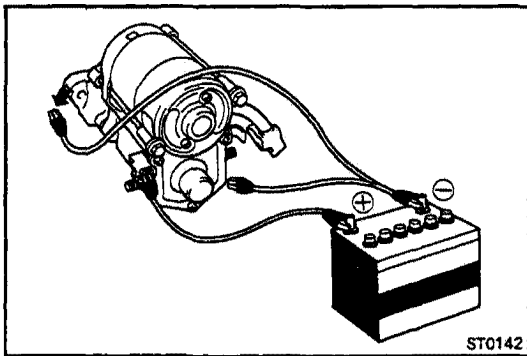
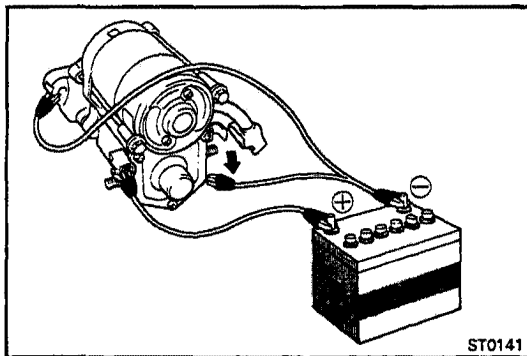
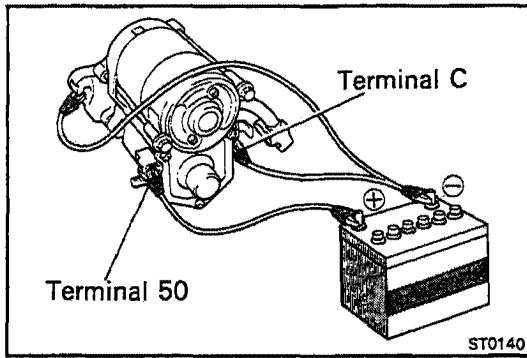

## PERFORMANCE TEST OF STARTER

**CAUTION:** These tests must be performed within 3 to 5 seconds to avoid burning out the coil.

### 1. PERFORM PULL-IN TEST

- Disconnect the field coil lead wire from terminal C.
- Connect the battery to the magnetic switch as shown. Check that the clutch pinion gear moves outward.

If the clutch pinion gear does not move, replace the magnetic switch assembly.

### 2. PERFORM HOLD-IN TEST

While connected as above with the clutch pinion gear out, disconnect the negative (-) lead from terminal C. Check that the pinion gear remains out.

If the clutch pinion gear returns inward, replace the magnetic switch assembly.

### 3. INSPECT CLUTCH PINION GEAR RETURN

Disconnect the negative (-) lead from the switch body. Check that the clutch pinion gear returns inward.

If the clutch pinion gear does not return, replace the magnetic switch assembly.

### 4. PERFORM NO-LOAD PERFORMANCE TEST

- Connect the battery and ammeter to the starter as shown.
- Check that the starter rotates smoothly and steadily with the pinion gear moving out. Check that the ammeter shows the specified current.

**Specified current: 90 A or less at 11.5 V**

## INSTALLATION OF STARTER

### 1. INSTALL STARTER

Install the starter and ground strap with the bolt and nut.

### 2. CONNECT CONNECTOR AND CABLE TO STARTER

### 3. CONNECT CABLE TO NEGATIVE TERMINAL OF BATTERY

### 4. CHECK THAT ENGINE STARTS



---

# CHARGING SYSTEM

	Page
PRECAUTIONS .....	CH-2
TROUBLESHOOTING .....	CH-2
ON-VEHICLE INSPECTION .....	CH-3
ALTERNATOR .....	CH-6
CHARGE LIGHT RELAY .....	CH-15

## PRECAUTIONS

1. Check that the battery cables are connected to the correct terminals.
2. Disconnect the battery cables when the battery is given a quick charge.
3. Do not perform tests with a high voltage insulation resistance tester.
4. Never disconnect the battery while the engine is running.

## TROUBLESHOOTING

Problem	Possible cause	Remedy	Page
Discharge warning light does not light with ignition ON and engine not running	Fuse blown Light burned out Wiring connections loose IC regulator faulty	Check "CHARGE" and "GAUGE" fuses Replace light Tighten loose connections Replace IC regulator	CH-6
Discharge warning light does not go out with engine running (battery requires frequent recharging)	Drive belt loose or worn Battery cables loose, corroded or worn Fuse blown Fusible link blown IC regulator or alternator faulty Wiring faulty	Adjust or replace drive belt Repair or replace cables Check "ENGINE" fuse Replace fusible link Check charging system Repair wiring	CH-3 CH-4

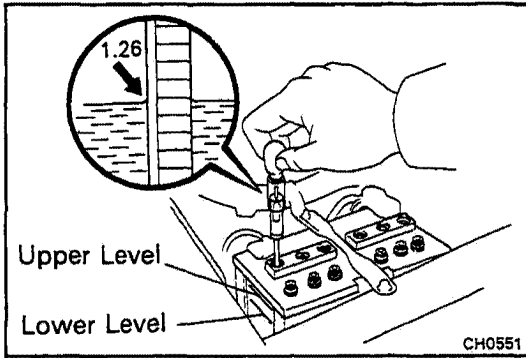

## ON-VEHICLE INSPECTION

### 1. CHECK BATTERY SPECIFIC GRAVITY

- (a) Check the specific gravity of each cell.

**Standard specific gravity**

**When fully charged at 20°C (68°F): 1.25 – 1.27**

If not within specification, charge the battery.

- (b) Check the electrolyte quantity of each cell.

If insufficient, refill with distilled (or purified) water.

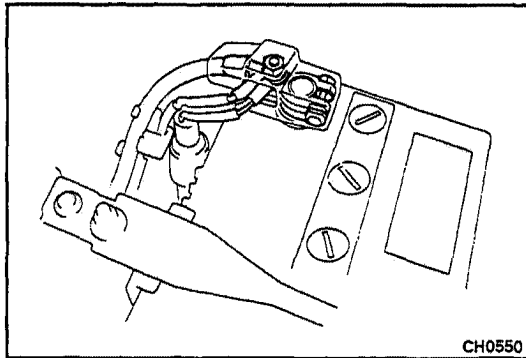

### 2. CHECK BATTERY TERMINALS, FUSIBLE LINKS AND FUSES

- (a) Check that the battery terminals are not loose or corroded.

- (b) Check the fusible links and fuses for continuity.

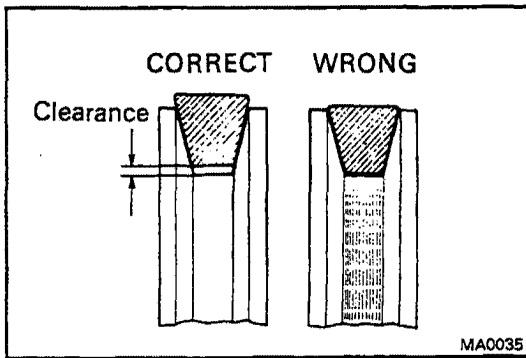

### 3. INSPECT DRIVE BELT

- (a) Visually check the drive belt for cracks, oiliness or wear. Check that the belt does not touch the bottom of the pulley groove.

If necessary, replace the drive belt.

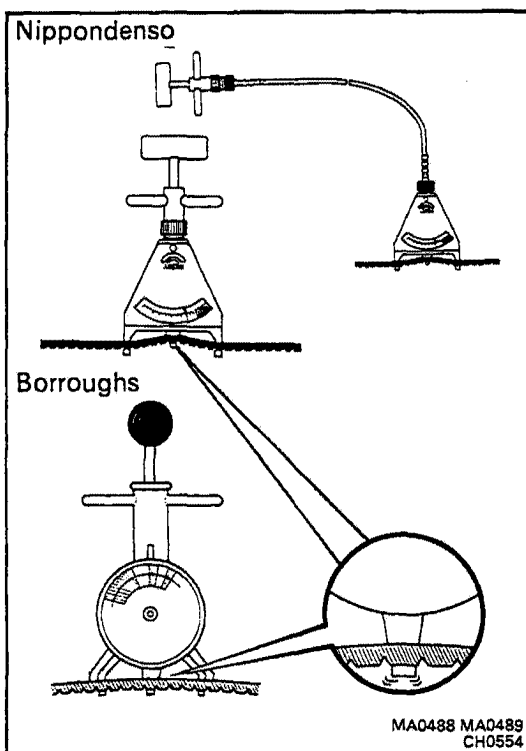

- (b) Using a belt tension gauge, check the drive belt tension.

Belt tension gauge:

Nippondenso BTG-20 (95506-00020) or

Borrroughs NO. BT-33-73F

**Drive belt tension: New belt 145 ± 25 lb**

**Used belt 100 ± 20 lb**

If the belt tension is not as specified, adjust it.

**NOTE:**

- When checking the tension, be sure the gauge is on the belt protrusion.
- "New belt" refers to a belt which has been used less than 5 minutes on a running engine.
- "Used belt" refers to a belt which has been used on a running engine for 5 minutes or more.
- After installing the belt, run the engine for about 5 minutes and recheck the tension.

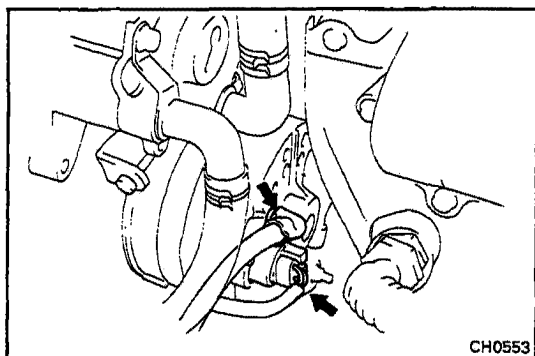

#### 4. VISUALLY CHECK ALTERNATOR WIRING AND LISTEN FOR ABNORMAL NOISES

- (a) Check that the wiring is in good condition.
- (b) Check that there are no abnormal noises from the alternator while the engine is running.

#### 5. CHECK DISCHARGE WARNING LIGHT CIRCUIT

- (a) Warm up the engine and turn it off.
- (b) Turn off all accessories.
- (c) Turn the ignition switch to "ON". Check that the charge light is lit.
- (d) Start the engine. Check that the light goes out.

If the light does come on and go off as specified, troubleshoot the discharge light circuit.

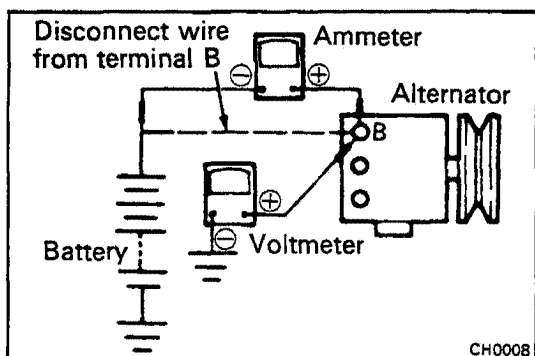

#### 6. INSPECT CHARGING CIRCUIT WITHOUT LOAD

**NOTE:** If a battery / alternator tester is available, connect the tester to the charging circuit according to the manufacturer's instructions.

- (a) If a tester is not available, connect a voltmeter and ammeter to the charging circuit as follows:
  - Disconnect the wire from terminal B of the alternator and connect the wire to the negative (-) terminal of the ammeter.
  - Connect the test lead from the positive (+) terminal of the ammeter to terminal B of the alternator.
  - Connect the positive (+) lead of the voltmeter to terminal B of the alternator.
  - Ground the negative (-) lead of the voltmeter.

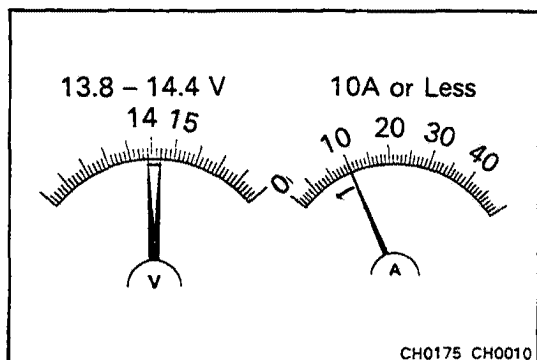

- (b) Check the charging circuit as follows:  
With the engine running from idling to 2,000 rpm, check the reading on the ammeter and voltmeter.

**Standard amperage: 10 A or less**

**Standard voltage: 13.8 – 14.4 V at 25°C (77°F)**

If the voltage reading is not within standard voltage, replace the IC regulator.

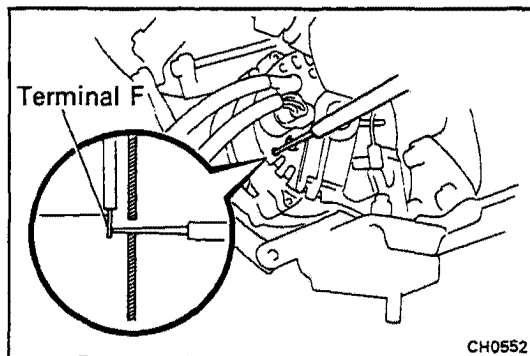

If the voltage reading is less than standard voltage, check the IC regulator and alternator as follows:

- With terminal F grounded, start the engine and check the voltage reading of terminal B.

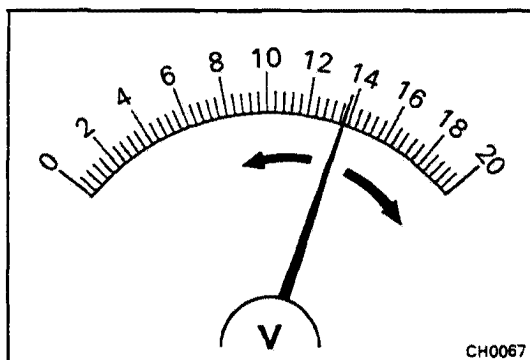

- If the voltage reading is more than standard voltage, replace the IC regulator.
- If the voltage reading is less than standard voltage, check the alternator.

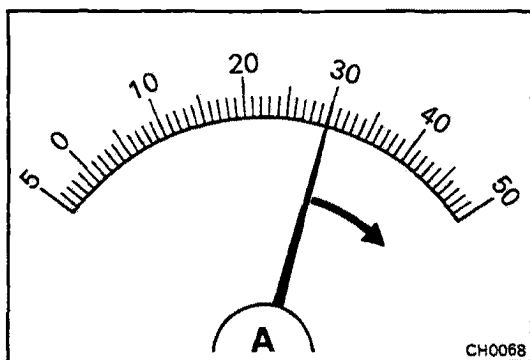

## 7. INSPECT CHARGING CIRCUIT WITH LOAD

- With the engine running at 2,000 rpm, turn on the high beam headlights and place the heater blower switch at "HI".
- Check the reading on the ammeter.

**Standard amperage: 30 A or more**

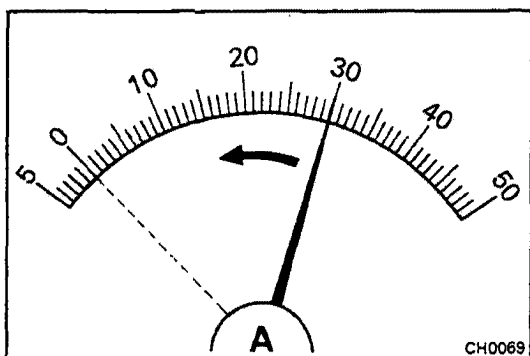

If the ammeter reading is less than 30 A, repair the alternator. (See page CH-6)

**NOTE:** With the battery is fully charged, the indication will sometimes be less than 30 A.

# ALTERNATOR COMPONENTS

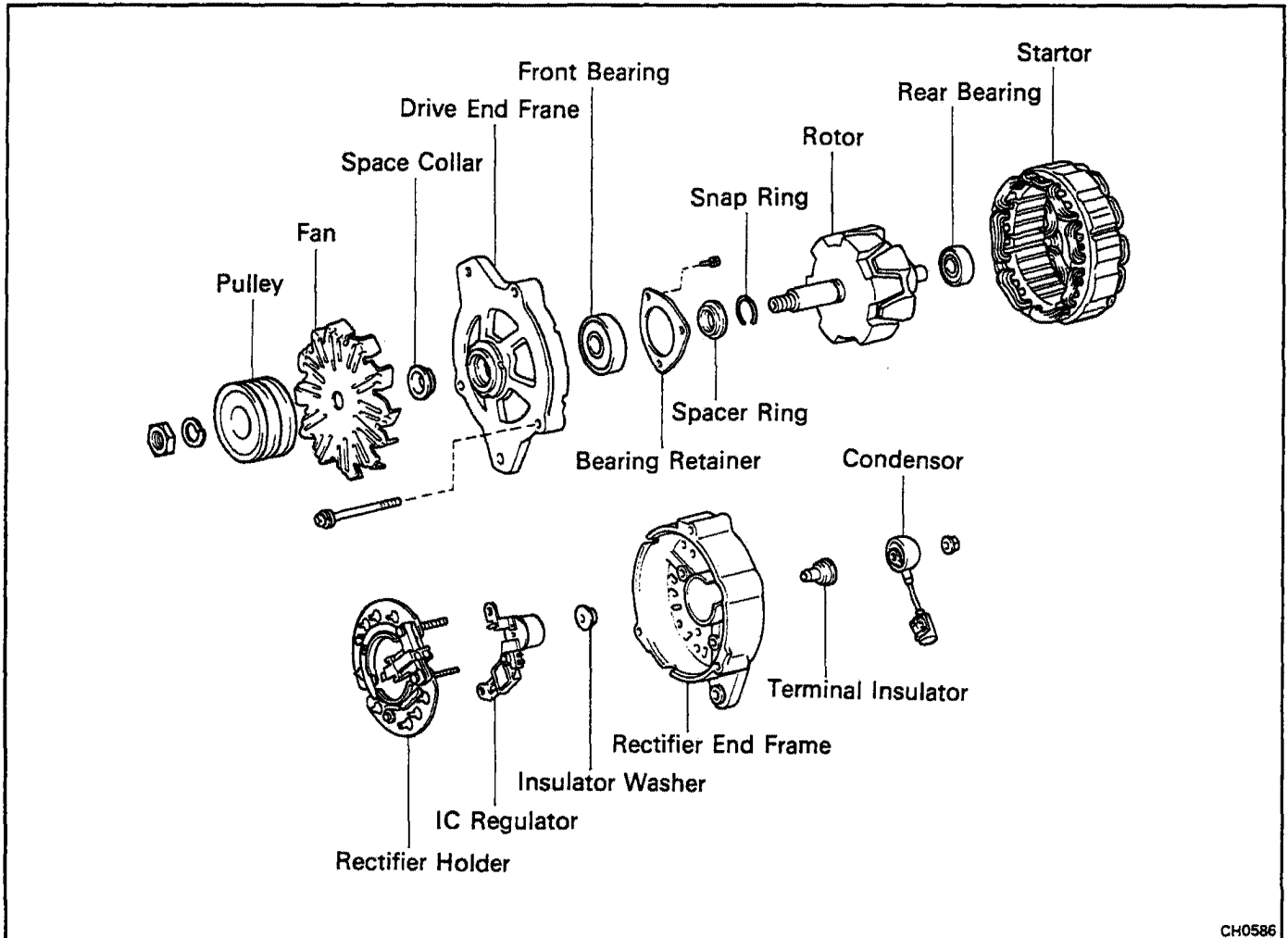

CH0586

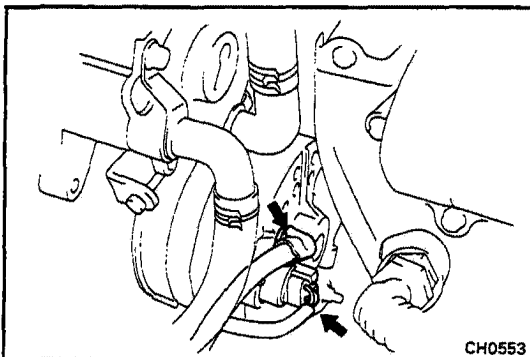

CH0553

## REMOVAL OF ALTERNATOR

1. **DISCONNECT CABLE FROM NEGATIVE TERMINAL OF BATTERY**
2. **DISCONNECT CONNECTOR AND WIRE FROM ALTERNATOR**
3. **REMOVE DRIVE BELTS**
4. **REMOVE ALTERNATOR**
  - (a) Remove the bolt, nut and air pump stay.
  - (b) Remove the adjusting lock bolt, two bolts and adjusting bar.
  - (c) Remove the pivot bolt, nut and alternator.

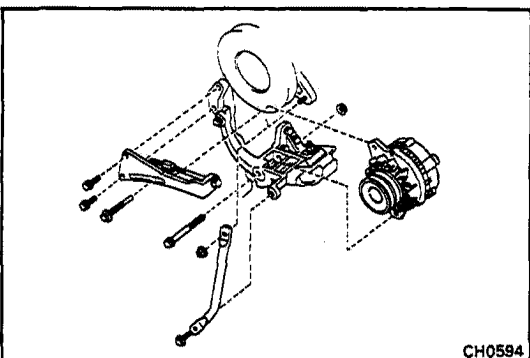

CH0594

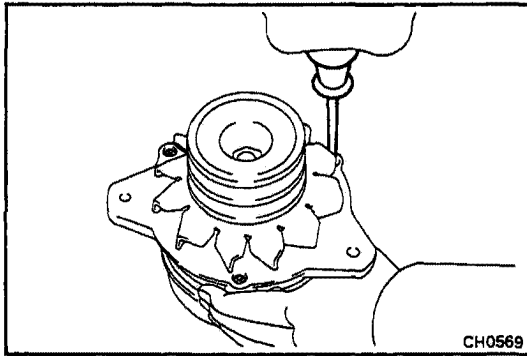

## DISASSEMBLY OF ALTERNATOR

(See page CH-6)

### 1. REMOVE DRIVE END FRAME AND ROTOR ASSEMBLY FROM STATOR

(a) Remove the three through screws.

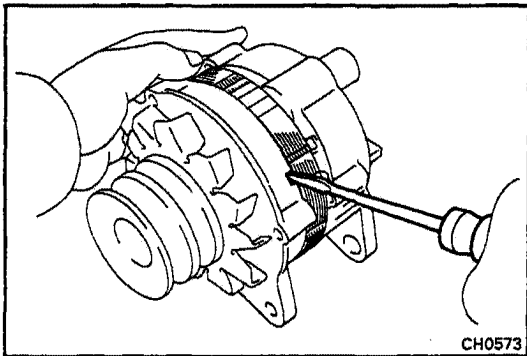

(b) Using a screwdriver, pry the end frame and remove it together with the rotor.

**CAUTION:** Do not pry on the coil wires.

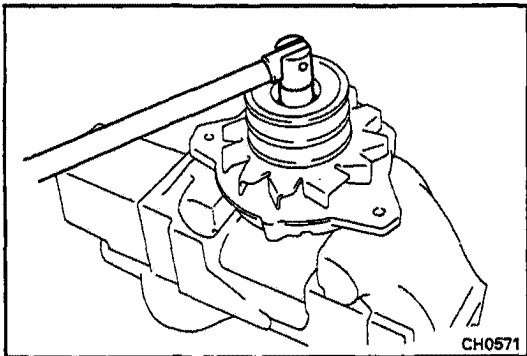

### 2. REMOVE PULLEY, FAN AND DRIVE END FRAME FROM ROTOR

(a) Mount the rotor in a soft jaw vise.

(b) Remove the pulley nut, spring washer, pulley and fan.

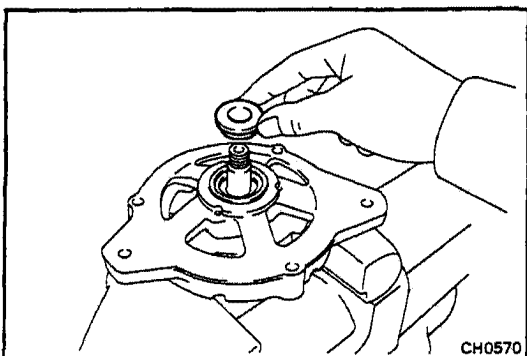

(c) Remove the spacer collar and drive end frame.

(d) Remove the spacer ring and snap ring.

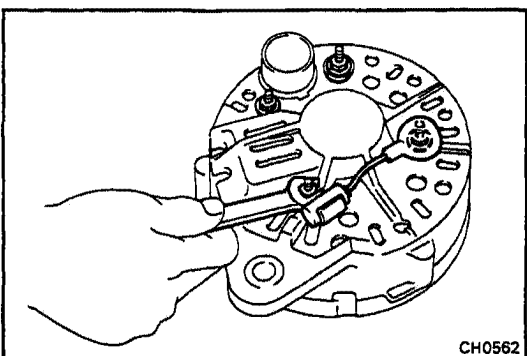

### 3. REMOVE RECTIFIER END FRAME

(a) Remove the four nuts, condenser and two terminal insulators.

(b) Remove the rectifier end frame.

(c) Remove the insulator washer from the rectifier holder stud.

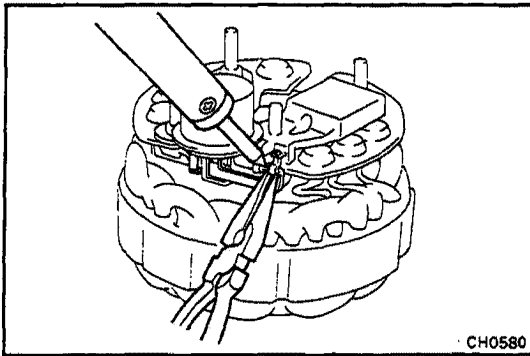

#### 4. REMOVE IC REGULATOR

Hold the IC regulator terminal with needle-nose pliers, and unsolder the terminals.

**CAUTION:** Protect the rectifiers from heat.

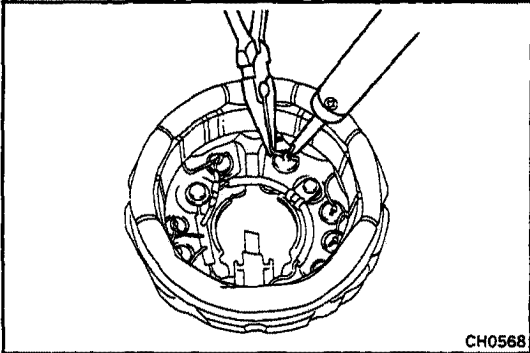

#### 5. REMOVE RECTIFIER HOLDER

Hold the stator coil lead with needle-nose pliers, and unsolder the leads.

**CAUTION:** Protect the rectifiers from heat.

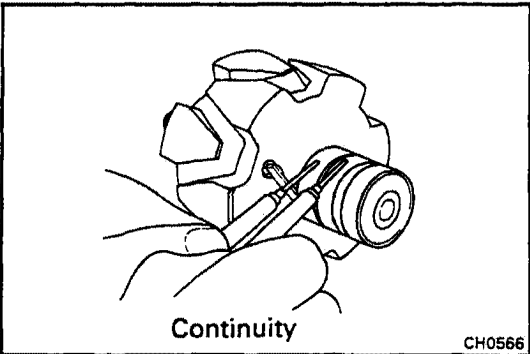

## INSPECTION AND REPAIR OF ALTERNATOR

### Rotor

#### 1. INSPECT ROTOR FOR OPEN CIRCUIT

Using an ohmmeter, check that there is continuity between the slip rings.

**Standard resistance:** 2.8 – 3.0  $\Omega$

If there is no continuity, replace the rotor.

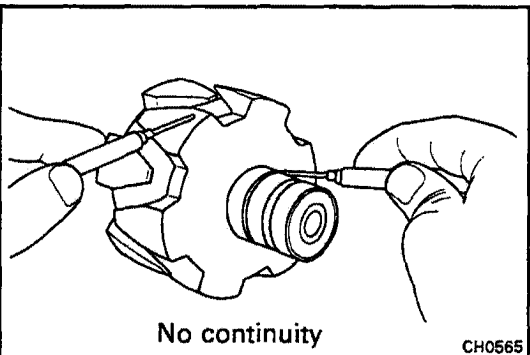

#### 2. INSPECT ROTOR FOR GROUND

Using an ohmmeter, check that there is no continuity between the slip ring and the rotor.

If there is continuity, replace the rotor.

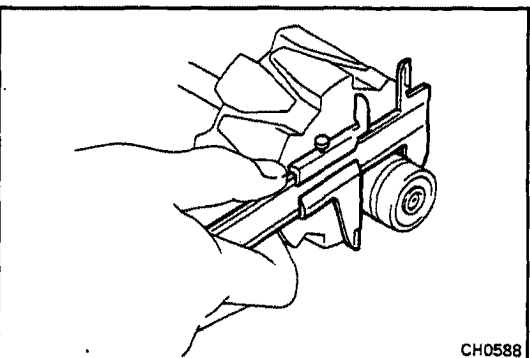

#### 3. INSPECT SLIP RINGS

(a) Check the slip rings are not rough or scored.

If rough or scored, replace the rotor.

(b) Using calipers, measure the slip ring diameters.

**Standard diameter:** 32.3 – 32.5 mm

(1.272 – 1.280 in.)

**Minimum diameter:** 32.1 mm (1.264 in.)

If the diameter is less than minimum, replace the rotor.

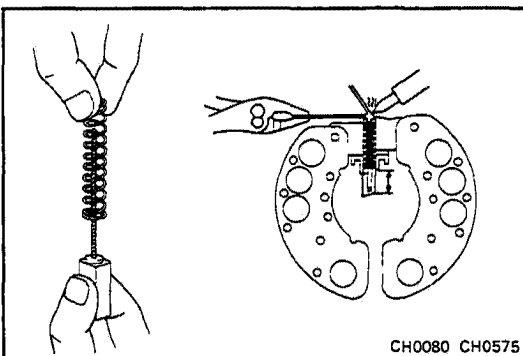
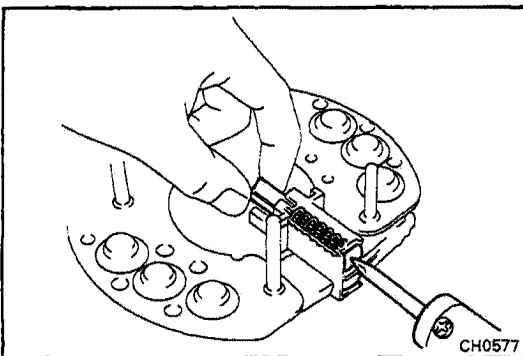
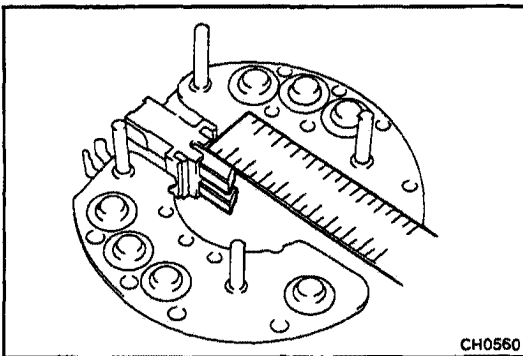
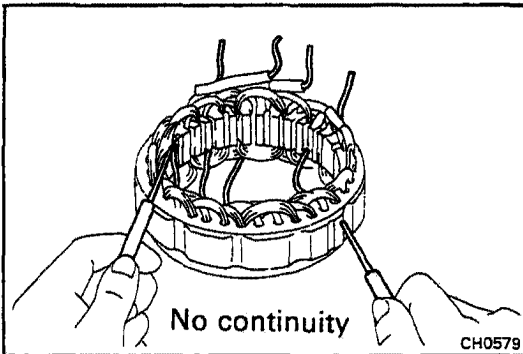
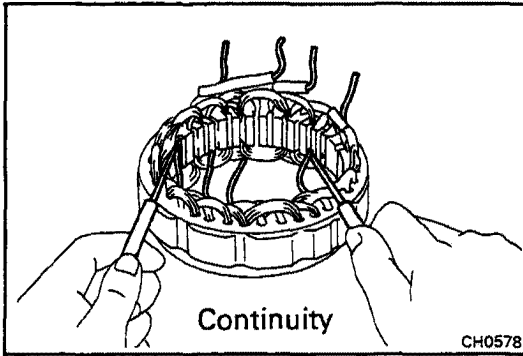

## Stator

### 1. INSPECT STATOR FOR OPEN CIRCUIT

Using an ohmmeter, check that there is continuity between the coil leads.

If there is no continuity, replace the stator.

### 2. INSPECT STATOR FOR GROUND

Using an ohmmeter, check that there is no continuity between the coil leads and stator core.

If there is continuity, replace the stator.

## Brushes

### 1. INSPECT EXPOSED BRUSH LENGTH

Using a scale, measure the exposed brush length.

**Standard exposed length: 20.0 mm (0.787 in.)**

**Minimum exposed length: 5.5 mm (0.217 in.)**

If the length is less than minimum, replace the brushes.

### 2. IF NECESSARY, REPLACE BRUSHES

(a) Unsolder and remove the brush and spring.

(b) Insert the brush wire through the spring.

(c) Install the brush in the brush holder.

(d) Solder the wire to the brush holder at specified exposed length.

**Exposed length: 20.0 mm (0.787 in.)**

(e) Check that the brush moves smoothly in the brush holder.

(f) Cut off any excess wire.

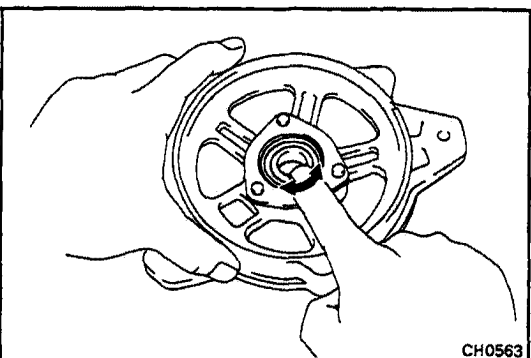
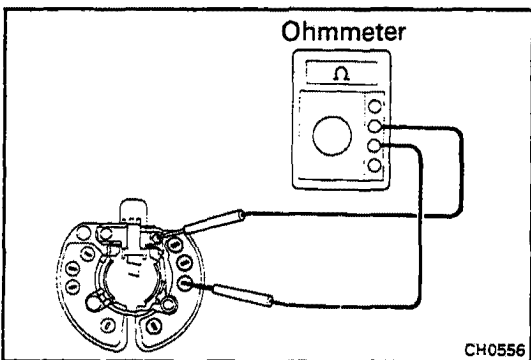
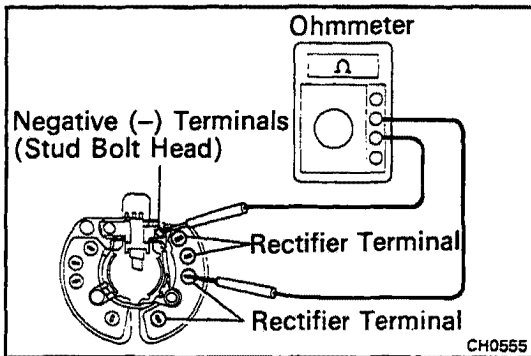
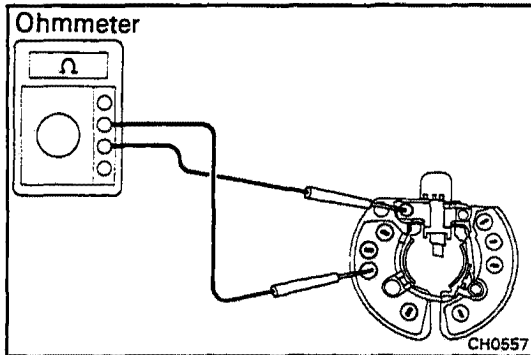
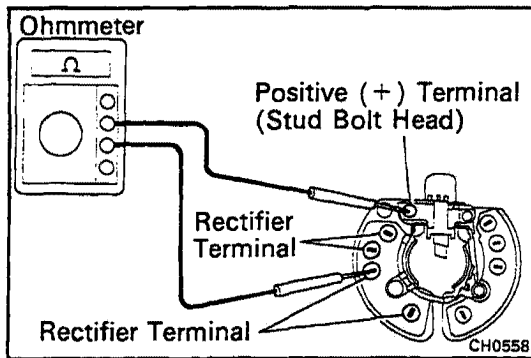

## Rectifiers (Rectifier Holder)

### 1. INSPECT POSITIVE SIDE RECTIFIER

(a) Using an ohmmeter, connect one tester probe to the positive (+) terminal and the other to each rectifier terminal.

(b) Reverse the polarity of the tester and repeat step (a).

(c) Check that one shows continuity and the other shows no continuity.

If continuity is not as specified, replace the rectifier holder.

### 2. INSPECT NEGATIVE SIDE RECTIFIER

(a) Using an ohmmeter, connect one tester probe to the negative (-) terminal and the other to each rectifier terminal.

(b) Reverse the polarity of the tester probes and repeat step (a).

(c) Check that one shows continuity and the other shows no continuity.

If continuity is not as specified, replace the rectifier holder.

## Bearings

### 1. INSPECT FRONT BEARING

Check that the bearing is not rough or worn.

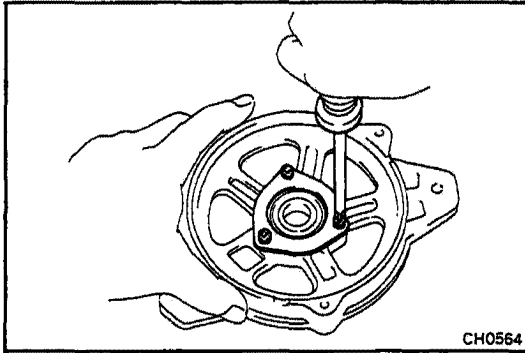
**2. IF NECESSARY, REPLACE FRONT BEARING**

Remove the three screws and bearing retainer, and replace the bearing.

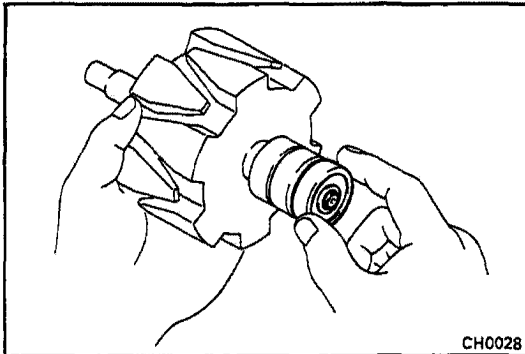
**3. INSPECT REAR BEARING**

Check that the bearing is not rough or worn.

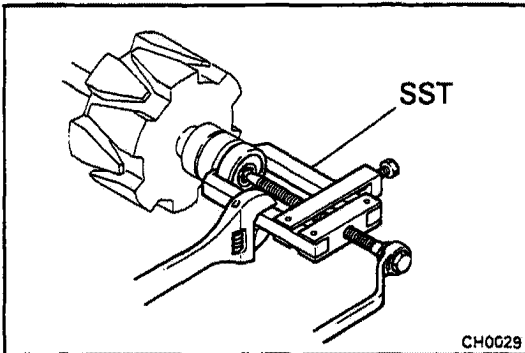
**4. IF NECESSARY, REPLACE REAR BEARING**

(a) Using SST, remove the bearing from the rotor shaft.  
SST 09286-46011

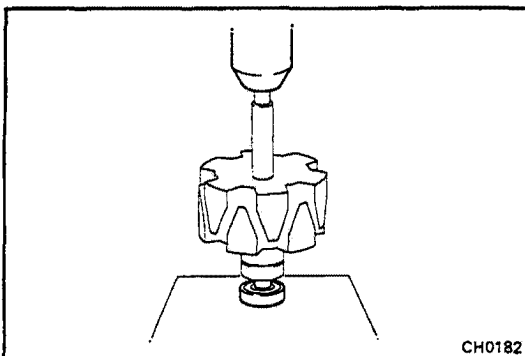

(b) Using a press, press in a new rear bearing onto the rotor shaft.

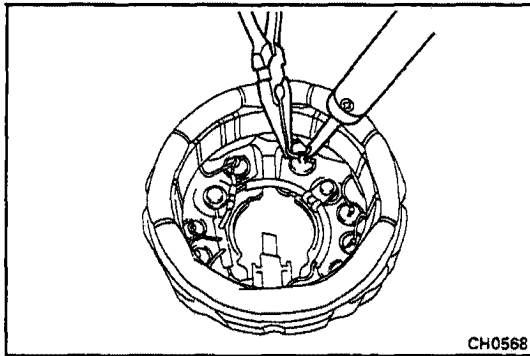

CH0568

## ASSEMBLY OF ALTERNATOR

(See page CH-6)

### 1. INSTALL RECTIFIER HOLDER TO STATOR

Hold the stator coil lead with needle-nose pliers while soldering the leads.

**CAUTION:** Protect the rectifiers from heat.

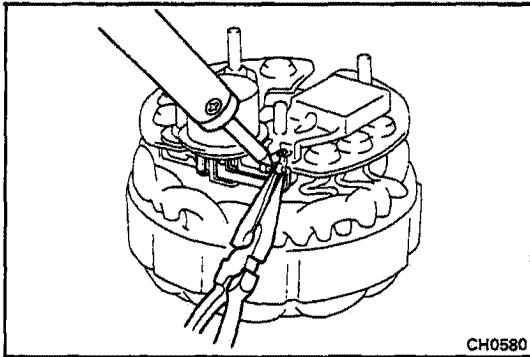

CH0580

### 2. INSTALL IC REGULATOR

Hold the IC regulator terminal with needle-nose pliers while soldering the terminals.

**CAUTION:** Protect the rectifiers from heat.

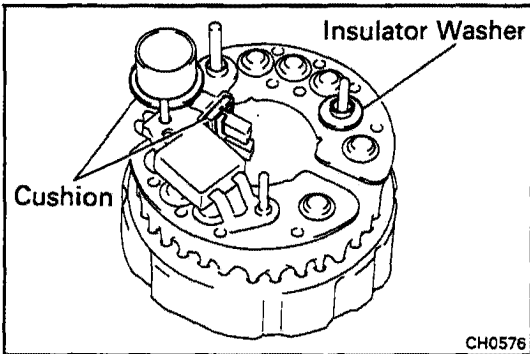

CH0576

### 3. INSTALL RECTIFIER END FRAME TO RECTIFIER HOLDER

(a) Place the insulator washer on the positive (+) stud of the rectifier holder.

(b) Place the two cushions on the brush holder and alternator terminal.

(c) Place the rectifier end frame on the rectifier holder.

(d) Check that the wires are not touching the rectifier end frame.

(e) Place the two terminal insulators on the positive (+) studs of the rectifier holder.

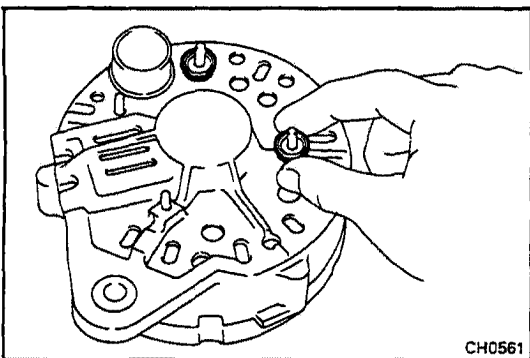

CH0561

(f) Install the condenser and four nuts.

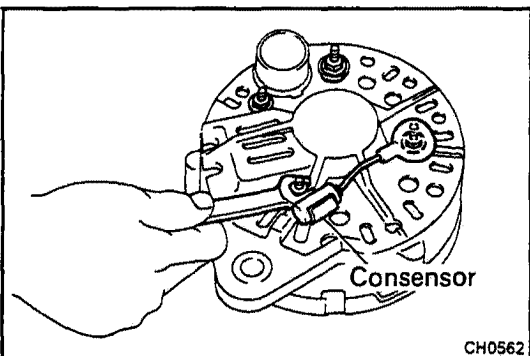

CH0562

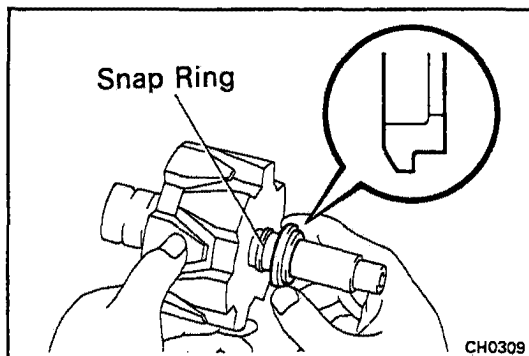

#### 4. INSTALL DRIVE END FRAME, FAN AND PULLEY TO ROTOR

- (a) Slide the snap ring and spacer ring onto the rotor shaft.

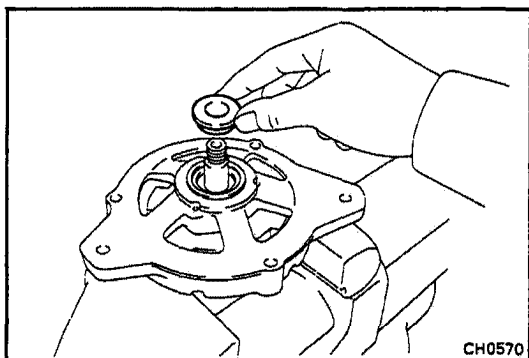

- (b) Mount the rotor in a soft jaw vise.  
 (c) Slide the drive end frame and spacer collar.

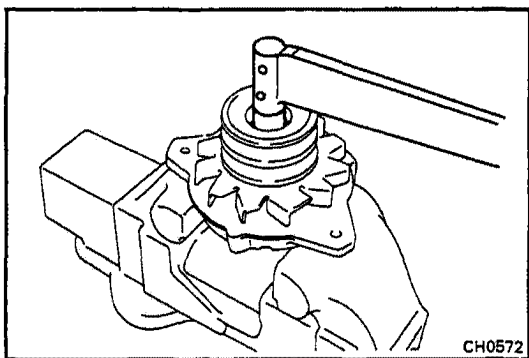

- (d) Slide the fan, pulley and spring washer onto the rotor shaft.

- (e) Install and torque the nut.

**Torque: 900 kg-cm (65 ft-lb, 88 N·m)**

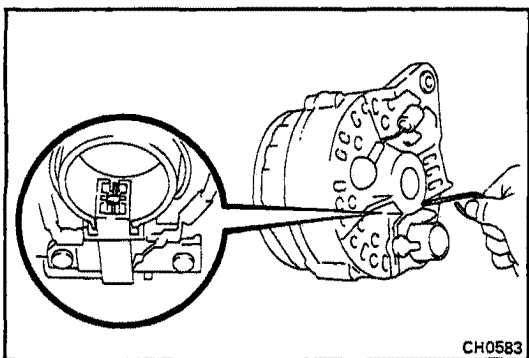

#### 5. ASSEMBLE DRIVE END FRAME AND RECTIFIER END FRAME

- (a) Bend the rectifier lead wires back to clear the rotor.  
 (b) Using a curved tool, push the brushes in as far as they will go and hold them in place by inserting a stiff wire through the access hole in the rectifier end frame.

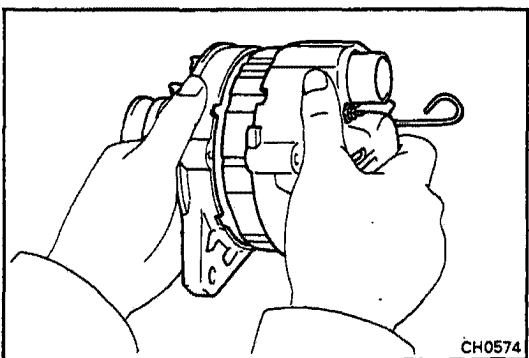

- (c) Assemble the drive end frame and the rectifier end frame by inserting the rear bearing on the rotor shaft into the rectifier end frame.

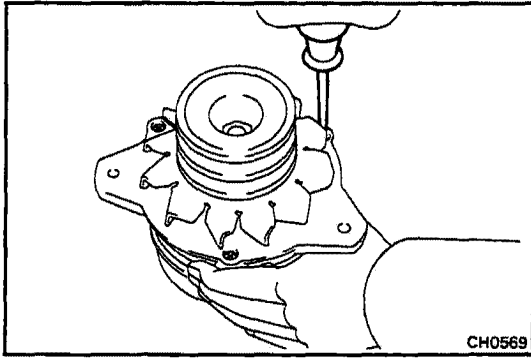

- (d) Install the three through screws.
- (e) Remove the stiff wire from the access hole.

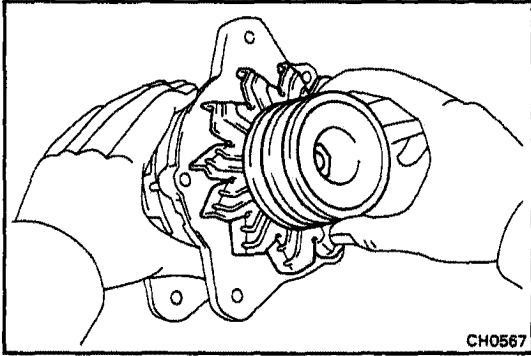

- (f) Check that the rotor rotates smoothly.
- (g) Seal the access hole.

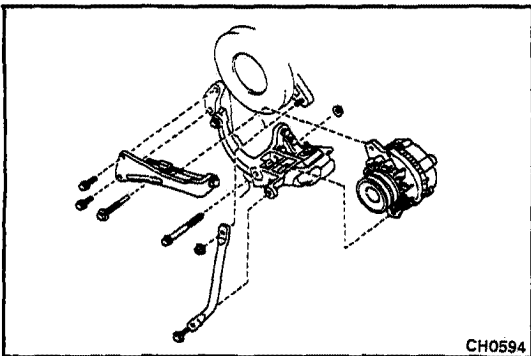

## INSTALLATION OF ALTERNATOR

### 1. INSTALL ALTERNATOR

- (a) Mount the alternator on the alternator bracket with pivot bolt and nut. Do not tighten the bolt and nut.
- (b) Install the adjusting bar with the two bolts and adjusting lock bolt. Do not tighten the adjusting lock bolt.
- (c) Install the air pump stay with the bolt and nut.

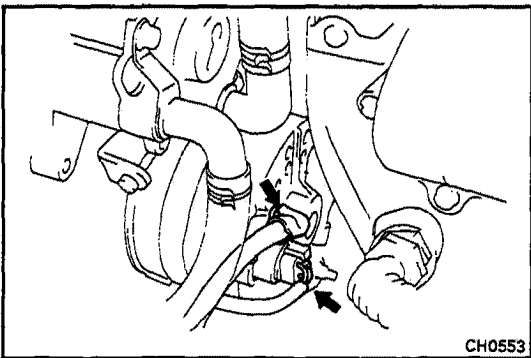

### 2. INSTALL DRIVE BELTS

- (a) Install the drive belt.
- (b) Using a belt tension gauge, adjust the belt tension. (See page CH-3)

Drive belt tension: **New belt** 145 ± 25 lb  
**Used belt** 100 ± 20 lb

- (c) Tighten the pivot and adjusting lock bolts.

### 3. CONNECT CONNECTOR AND WIRE TO ALTERNATOR

### 4. CONNECT CABLE TO NEGATIVE TERMINAL OF BATTERY

### 5. PERFORM ON-VEHICLE INSPECTION (See steps 5 to 7 on pages CH-4, 5)

## CHARGE LIGHT RELAY

### INSPECTION OF CHARGE LIGHT RELAY

**LOCATION:** Inside of the passenger's cowl side trim.

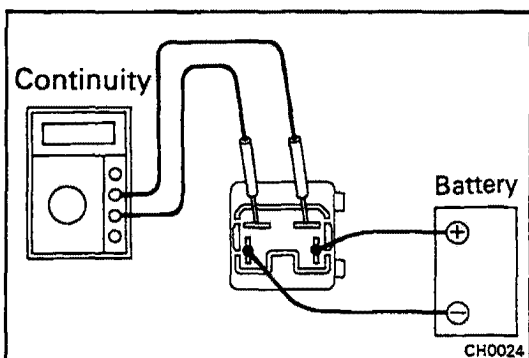
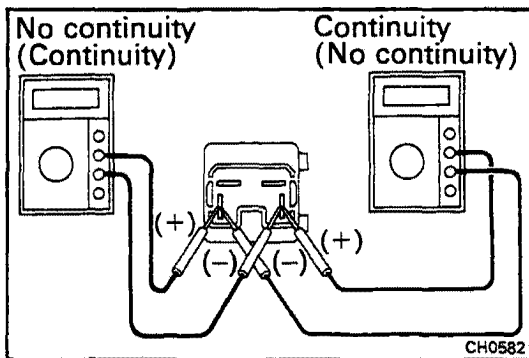
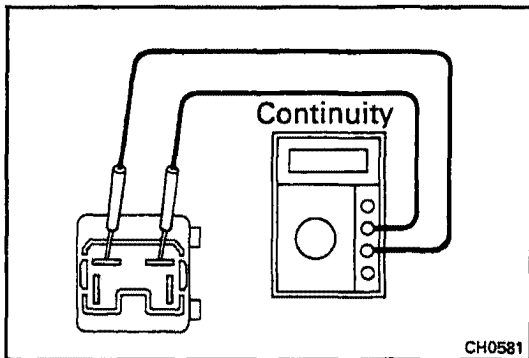
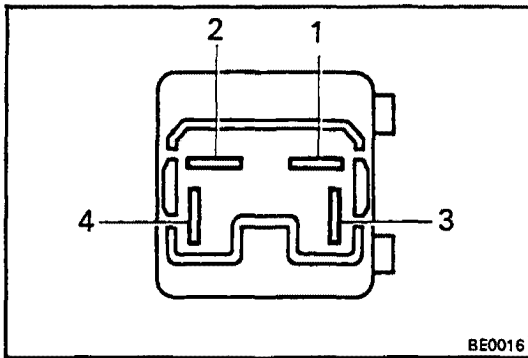

#### 1. INSPECT RELAY CONTINUITY

(a) Using an ohmmeter, check that there is no continuity between terminals 1 and 2.

(b) Connect the one test probe to terminal 3 and the other to terminal 4.

(c) Reverse the polarity of test probes, and repeat step (b).

(d) Check that one shows continuity and other shows no continuity.

If continuity is not as specified, replace the relay.

#### 2. INSPECT RELAY OPERATION

(a) Connect a positive (+) lead from the battery to terminal 3.

(b) Connect a negative (-) lead from the battery to terminal 4.

(c) Using an ohmmeter, check for continuity between terminals 1 and 2.

If operation is not as specified, replace the relay.



# AUTOMATIC TRANSMISSION (A440F)

## REFER TO FOLLOWING REPAIR MANUALS

Repair Manual	Pub. No.	Mentioned Items
Chassis & Body LAND CRUISER (Heavy-Duty)	36262E	Troubleshooting On-Vehicle Repair
A440F, A440L Automatic Transmission	36264E	Disassembly and Assembly of Transmission

NOTE: The following page contains only the points which differ from the above listed-manuals.

	Page
<b>TESTS</b> .....	<b>AT-2</b>
<b>Stall Test</b> .....	<b>AT-2</b>
<b>Hydraulic Test</b> .....	<b>AT-2</b>
<b>AUTOMATIC SHIFT DIAGRAM</b> .....	<b>AT-2</b>

**AT**

## TESTS

### STALL TEST

#### MEASURE STALL SPEED

For stall speed measurement methods, please refer to page AT-7 of the Repair Manual for Chassis and Body of the Land Cruiser (Heavy-Duty), Pub. No. 36262E.

Stall speed: 3F-E engine 1,950 ± 150 rpm

### HYDRAULIC TEST

#### MEASURE GOVERNOR PRESSURE

For governor pressure measurement methods, please refer to page AT-9 of the Repair Manual for Chassis and Body of the Land Cruiser (Heavy-Duty), Pub. No. 36262E.

Output shaft rpm	Vehicle speed (Reference)	Governor pressure kg/cm <sup>2</sup> (psi, kPa)
1,000	32 km/h (20 mph)	0.8 – 1.2 (11 – 17, 78 – 118)
1,800	57 km/h (35 mph)	1.9 – 2.3 (27 – 33, 186 – 226)
3,500	111 km/h (69 mph)	5.7 – 6.3 (81 – 90, 559 – 618)

## AUTOMATIC SHIFT DIAGRAM

km/h (mph)

Tire Size	D range (throttle valve fully open)						(fully closed)		2 range	L range
	1→2	2→3	3→O/D	O/D→3	3→2	2→1	Lock-up ON	Lock-up OFF	3→2	2→1
P225/75 R15	34-48 (21-30)	74-88 (46-55)	109-123 (68-76)	102-116 (63-72)	64-78 (40-48)	29-43 (18-27)	79-92 (49-57)	75-88 (47-55)	81-95 (50-59)	36-50 (22-31)

# FRONT AXLE AND SUSPENSION

REFER TO LAND CRUISER (Heavy-Duty) REPAIR  
MANUAL FOR CHASSIS AND BODY  
(Pub. No. 36262E)

NOTE: The following pages contain only the points which  
differ from the above listed manual.

	<b>Page</b>
<b>TROUBLESHOOTING .....</b>	<b>FA-2</b>
<b>FRONT WHEEL ALIGNMENT .....</b>	<b>FA-2</b>
<b>FRONT AXLE HUB .....</b>	<b>FA-5</b>
<b>STEERING KNUCKLE AND AXLE SHAFT ...</b>	<b>FA-10</b>
<b>FRONT SUSPENSION .....</b>	<b>FA-11</b>

# TROUBLESHOOTING

Problem	Possible cause	Remedy	Page
Wanders/pulls	Alignment incorrect	Check front end alignment	FA-2
Front wheel shimmy	Tires worn or improperly inflated Wheels out of balance Alignment incorrect	Replace tire or inflate tires to proper pressure Balance wheels Check front end alignment	FA-2
Abnormal tire wear	Alignment incorrect	Check toe-in	FA-2

## FRONT WHEEL ALIGNMENT

### 1. MAKE FOLLOWING CHECKS AND CORRECT ANY PROBLEMS

- (a) Check the tires for wear and proper inflation.

Cold tire inflation pressure kg/cm<sup>2</sup> (psi, kPa)

Tire size	Front	Rear
P225/75R15 EXTRA LOAD	1.8 (26, 177)	2.4 (34, 235)

- (b) Check the wheel runout.

**Lateral runout: Less than 1.2 mm (0.047 in.)**

- (c) Check the front wheel bearings for looseness.
- (d) Check the front suspension for looseness.
- (e) Check the steering linkage for looseness.
- (f) Use the standard bounce test to check that the front absorbers work properly.

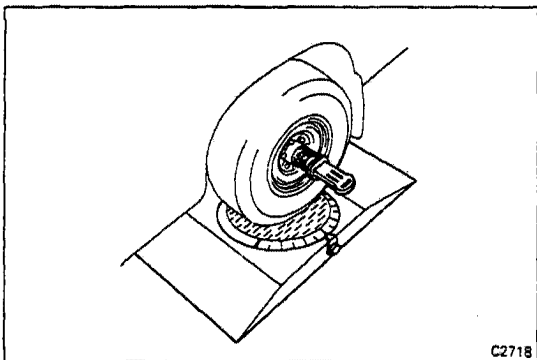
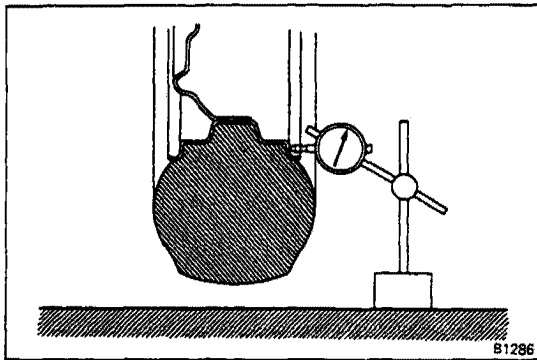

### 2. INSTALL WHEEL ALIGNMENT EQUIPMENT

Follow the specific instructions of the equipment manufacturer.

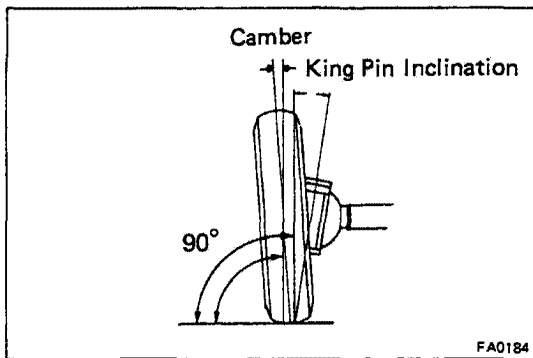

**3. CHECK CAMBER AND KING PIN INCLINATION**

**Camber:**  $1^\circ \pm 45'$   
**King pin inclination:**  $9^\circ 30' \pm 45'$

If camber or king pin inclination checks are not within specification, recheck the steering knuckle parts and the front wheel for bending or looseness.

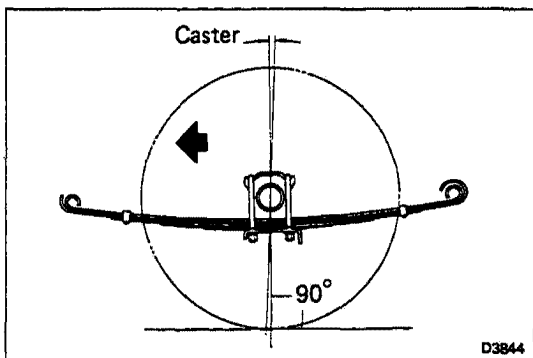

**4. CHECK CASTER**

**Caster:**  $50' \pm 1^\circ$

If caster is not as specified, inspect and replace damaged or worn parts.

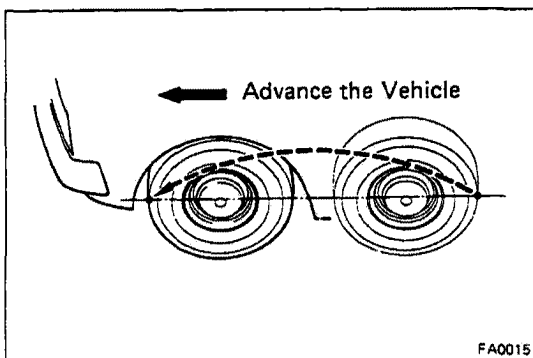

**5. ADJUST TOE-IN**

- (a) Make sure the wheels are positioned straight ahead.
- (b) Make the center of each rear tread at spindle height and measure the distance between the marks of right and left tires.
- (c) Advance the vehicle until the marks on the rear side of the tires come to the front.

**NOTE:** The toe-in should be measured at the same point on the tire and at the same level.

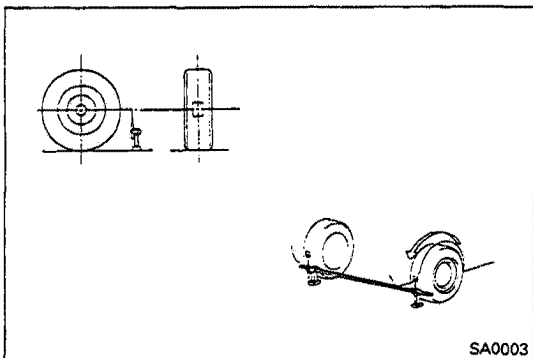

- (d) Measure the distance between the marks on the front side of the tires.

Toe-in		mm (in.)
Inspection STD	Adjustment STD	
$1 \pm 2$ (0.04 $\pm$ 0.08)	$1 \pm 1$ (0.04 $\pm$ 0.04)	

- (e) Make sure the steering gear is centered.
- (f) Loosen the nuts holding the clamps to the tie rod.
- (g) Adjust toe-in to the correct value by turning the tie rod.
- (h) Torque the nuts holding the clamps.

**Torque:** 375 kg-cm (27 ft-lb, 37 N·m)

**NOTE:** Insure that the lengths of the tie rod ends are the same.

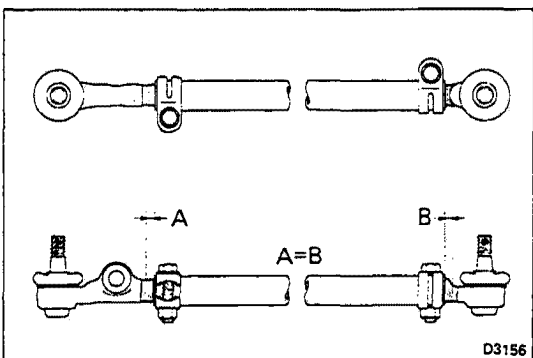

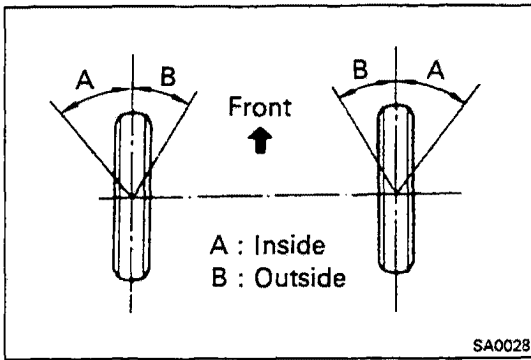

**6. ADJUST WHEEL ANGLE**

Remove the caps of the knuckle stopper bolts and check the steering angles.

Wheel angle		
Max.	Inside wheel	$32^{\circ} + 0^{\circ}$ $- 3^{\circ}$
	Outside wheel	$30^{\circ}$
at $20^{\circ}$ (Outside wheel)	Inside wheel	$21^{\circ}$

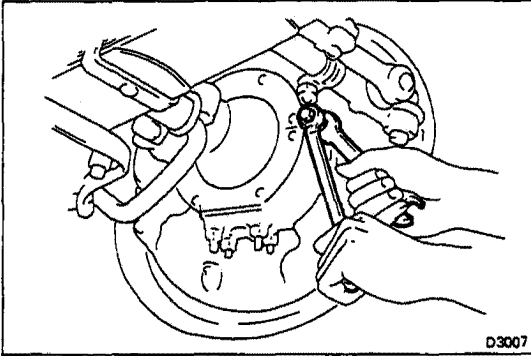

**NOTE:** When the steering wheel is fully turned, make sure that the wheel is not touching the body or brake flexible hose.

If maximum steering angles differ from the standard value, adjust the wheel angle with the knuckle stopper bolts.

**Torque: 450 kg-cm (33 ft-lb, 44 N·m)**

If the wheel angle still cannot be adjusted within limits, inspect and replace damaged or worn steering parts.

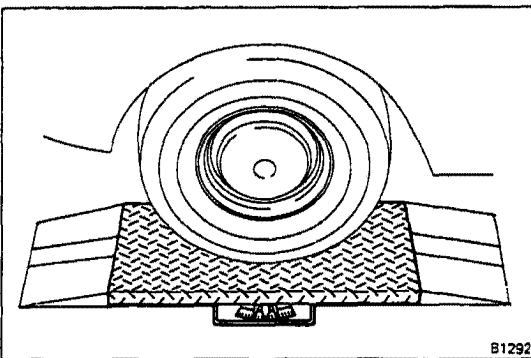

**7. INSPECT SIDE SLIP WITH SIDE SLIP TESTER**

**Side slip limit:**

**Less than 3.0 mm/m (0.118 in./3.3 ft)**

If the side slip exceeds the limit, the toe-in or other front wheel alignment may not be correct.

# FRONT AXLE HUB

The wheel nut tightening torque has been changed as follows.  
 Torque: 1,600 kg-cm (116 ft-lb, 157 N-m)

## COMPONENTS

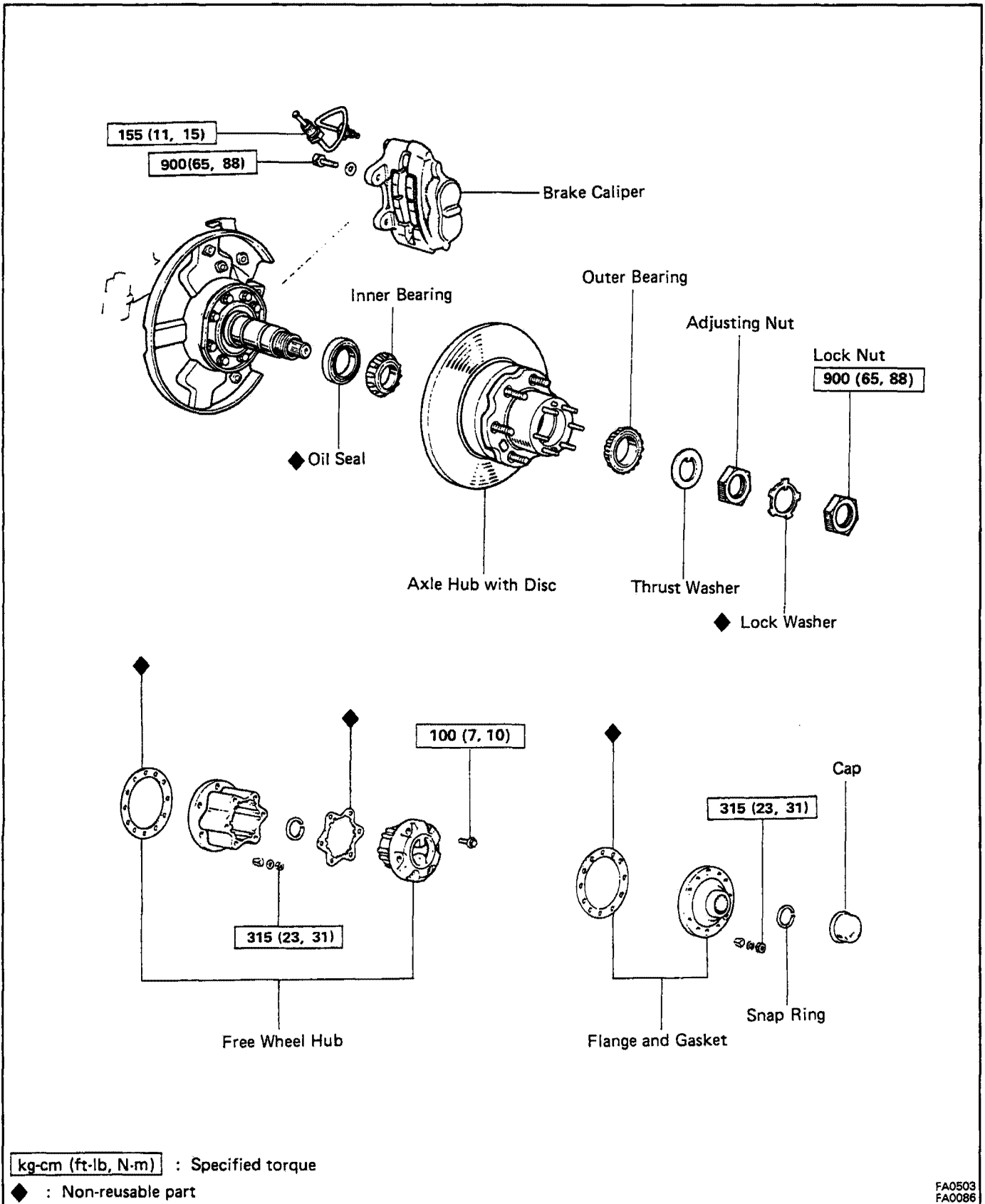

## Front Axle Hub

### DISASSEMBLY OF FRONT AXLE HUB

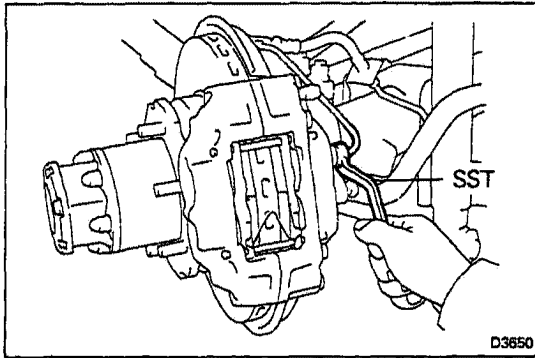

#### 1. REMOVE DISC BRAKE CYLINDER

- (a) Using SST, disconnect the brake tube.
- SST 09751-36011
- (b) Remove the brake caliper.

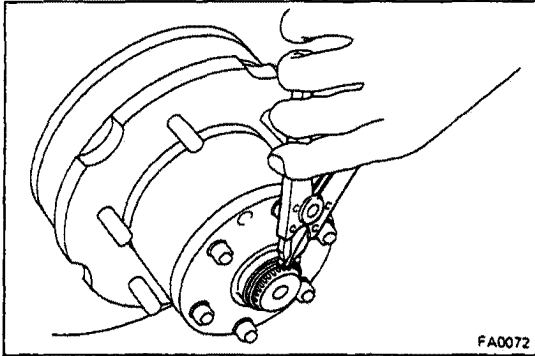

#### 2. REMOVE FLANGE OR FREE WHEEL HUB

NOTE: For the free wheel hub. (See page FA-7 repair manual chassis and body LAND CRUISER Heavy-Duty Pub. No. 36262E)

- (a) Remove the cap from the flange.
- (b) Using snap ring pliers, remove the snap ring.
- (c) Remove the mounting nuts.

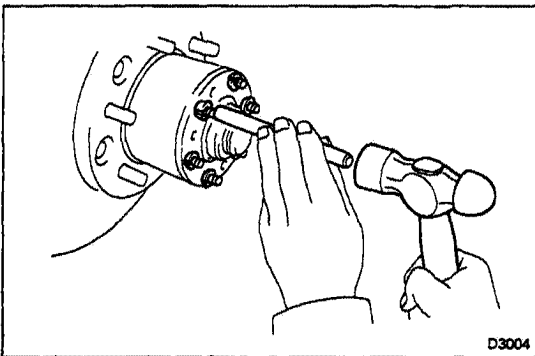

- (d) Using a brass bar and hammer, tap the bolt heads and remove the cone washers.

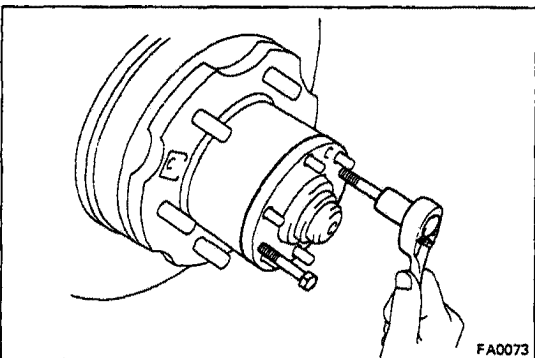

- (e) Install and tighten the two bolts, and remove the flange.

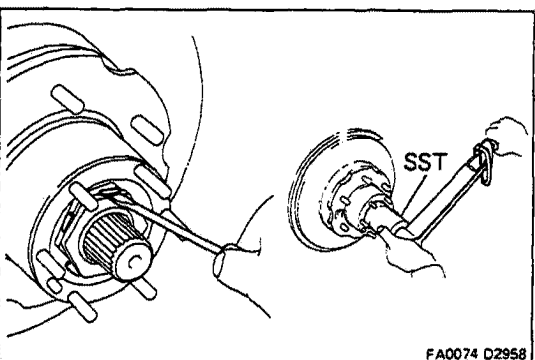

#### 3. REMOVE AXLE HUB WITH DISC

- (a) Using a screwdriver, release the lock washer.
- (b) Using SST, remove the lock nut.
- SST 09607-60020
- (c) Remove the lock washer and adjusting nut.
- (d) Remove the axle hub with the disc.

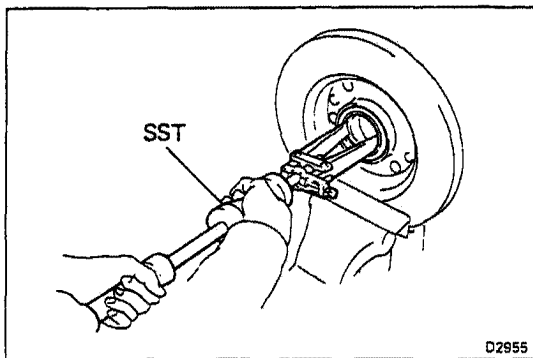
**4. REMOVE INNER BEARING AND OIL SEAL**

- (a) Using SST, remove the oil seal.
- SST 09308-00010
- (b) Remove the inner bearing from the hub.

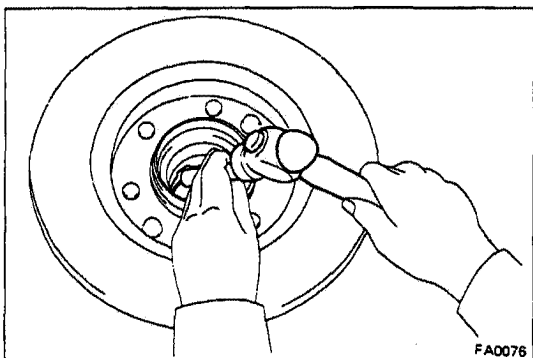
**INSPECTION AND REPAIR OF FRONT AXLE HUB****1. INSPECT BEARING**

Clean the bearings and outer races and inspect them for wear or damage.

**2. REPLACE BEARING OUTER RACE**

- (a) Using a brass bar and hammer, drive out the bearing outer race.
- (b) Using SST, carefully drive in the new bearing outer race.

SST 09608-35014

Inner Bearing (09608-06020, 09608-06210)

Outer Bearing (09608-06020, 09608-06200)

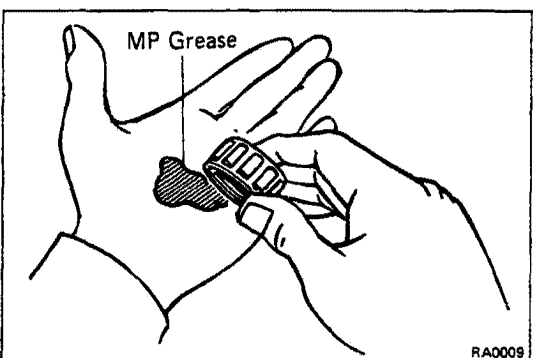
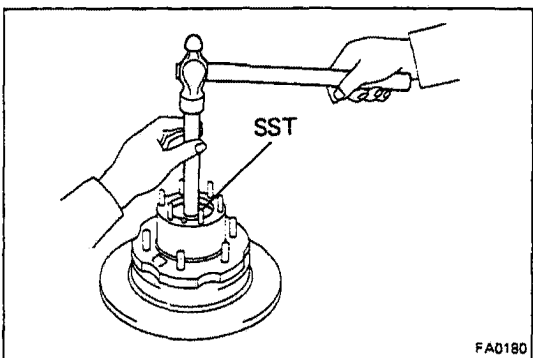
**ASSEMBLY OF FRONT AXLE HUB**

(See page FA-5)

**1. PACK BEARINGS WITH MP GREASE**

- (a) Place MP grease in the palm of your hand.
- (b) Pack grease into the bearing, continuing until the grease oozes out from the other side.
- (c) Do the same around the bearing circumference.

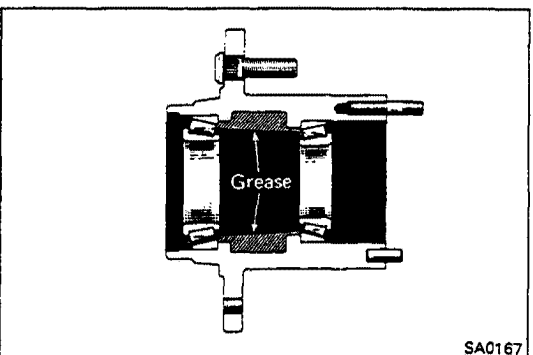
**2. COAT INSIDE OF HUB AND CAP WITH MP GREASE**

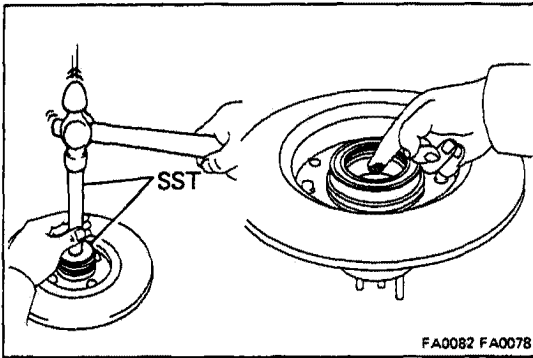

### 3. INSTALL INNER BEARING AND OIL SEAL

Place inner bearing into the hub. Using SST, drive the oil seal into the hub. Coat the oil seal with MP grease.  
SST 09608-35014 (09608-06020, 09608-06150)

### 4. INSTALL AXLE HUB ON SPINDLE

- (a) Place the axle hub on the spindle.
- (b) Install the outer bearing and thrust washer.

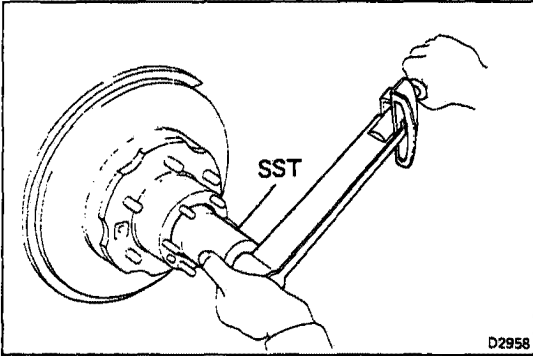

### 5. ADJUST PRELOAD

- (a) Using SST, torque the bearing adjusting nut.  
SST 09607-60020

**Torque: 600 kg-cm (43 ft-lb, 59 N-m)**

- (b) Turn the hub right and left two or three times.
- (c) Using SST, retighten the bearing adjusting nut.  
SST 09607-60020

**Torque: 600 kg-cm (43 ft-lb, 59 N-m)**

- (d) Loosen the nut until it can be turned by hand.
- (e) Using a spring tension gauge, measure the frictional force of the oil seal at the hub bolt.
- (f) Retighten the adjusting nut.

**Torque:**

**40 – 70 kg-cm (35 – 60 in.-lb, 4.0 – 6.8 N-m)**

- (g) Using a spring tension gauge, measure the preload.

**Preload (starting):**

**Frictional force plus**

**2.8 – 5.7 kg (6.2 – 12.5 lb, 27.5 – 55.8 N)**

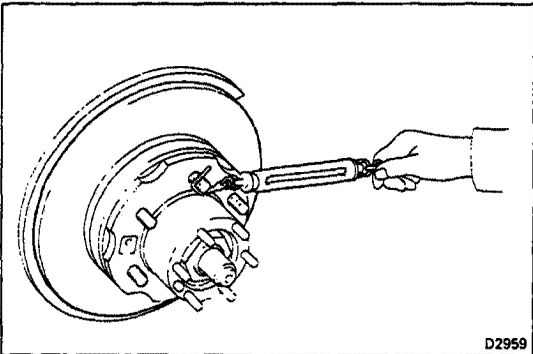

### 6. INSTALL LOCK WASHER AND LOCK NUT

- (a) Install the lock washer and lock nut.
- (b) Using SST, torque the lock nut.

SST 09607-60020

**Torque: 900 kg-cm (65 ft-lb, 88 N-m)**

- (c) Check that the bearing has no play.
- (d) Using a spring tension gauge, check the preload.

**Preload (starting):**

**Frictional force plus**

**2.8 – 5.7 kg (6.2 – 12.5 lb, 27.5 – 55.8 N)**

If not within specification, adjust with the adjusting nut.

- (e) Secure the lock nut by bending one of the lock washer teeth inward and another lock washer tooth outward.

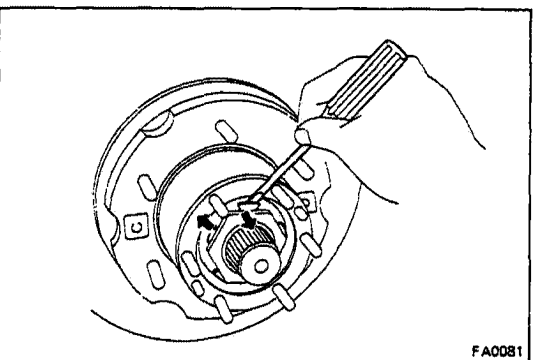
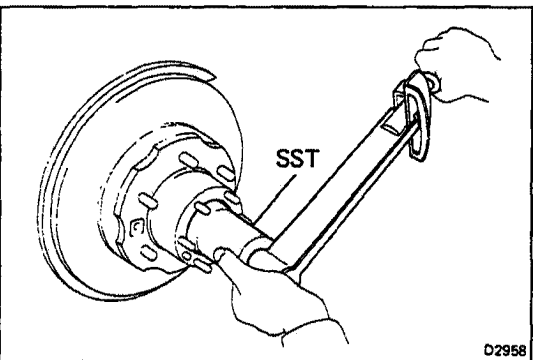

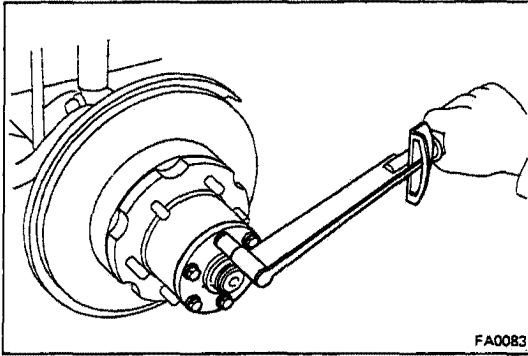

FA0083

## 7. INSTALL FLANGE OR FREE WHEEL HUB

NOTE: In the case of the free wheel hub. (See page FA-9 repair manual chassis and body LAND CRUISER Heavy-Duty pub. No. 36262E)

- (a) Place the gasket in position on the axle hub.
- (b) Install the flange to the axle hub.
- (c) Install six cone washers and nuts.  
Torque the nuts.

**Torque: 315 kg-cm (23 ft-lb, 31 N-m)**

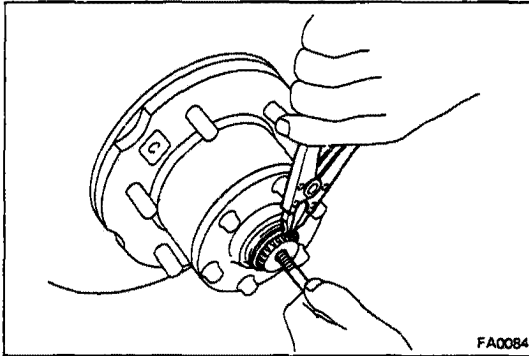

FA0084

- (d) Install a bolt in the axle shaft and pull it out.
- (e) Using snap ring pliers, install the snap ring.
- (f) Remove the bolt.
- (g) Install the cap to the flange.

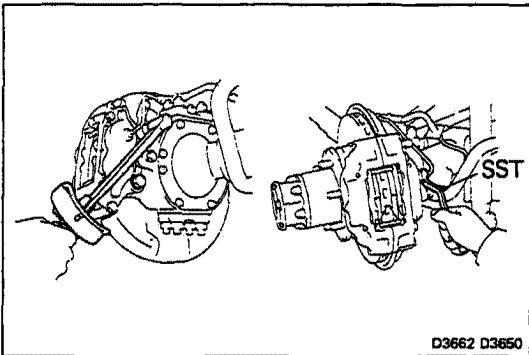

D3662 D3650

## 8. INSTALL BRAKE CALIPER

- (a) Install the brake caliper to the steering knuckle.  
Torque the mounting bolts.

**Torque: 900 kg-cm (65 ft-lb, 88 N-m)**

- (b) Using SST, connect the brake tube.

**Torque: 155 kg-cm (11 ft-lb, 15 N-m)**

## 9. BLEED BRAKE LINE

(See page BR-6 repair manual chassis and body LAND CRUISER Heavy-Duty Pub. No. 36262E)

# STEERING KNUCKLE AND AXLE SHAFT

For disassembly, inspection, repair, adjustment and reassembly of the steering knuckle and axle shaft, refer to the repair manual chassis and body LAND CRUISER (Heavy-Duty) Pub. No. 36262E.

## COMPONENTS

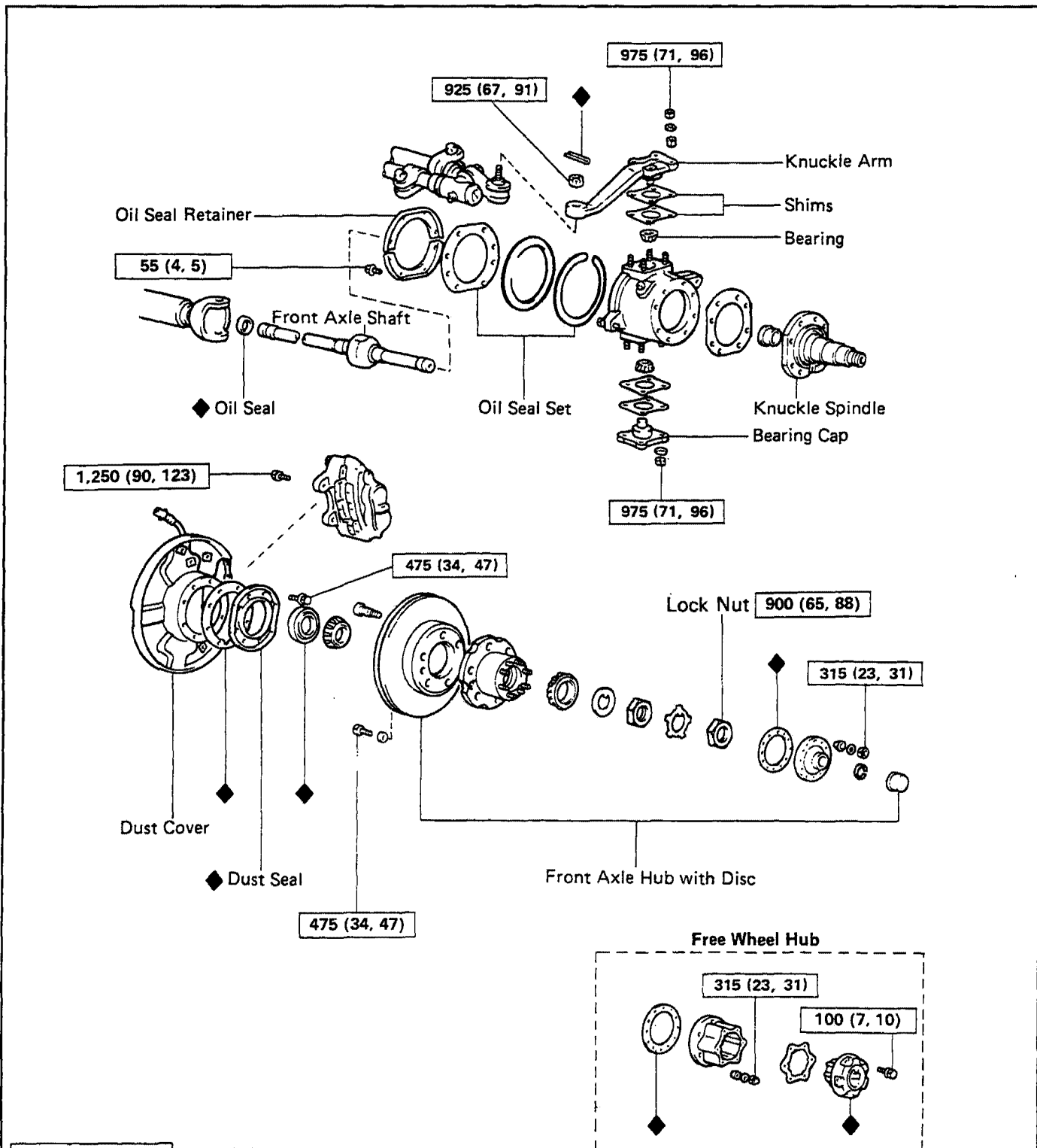

kg-cm (ft-lb, N-m) : Specified torque

◆ Non-reusable part

# FRONT SUSPENSION

For removal, installation of the leaf spring, shock absorber and stabilizer bar refer to the repair manual chassis and body LAND CRUISER (Heavy-Duty) Pub. No. 36262E.

## COMPONENTS

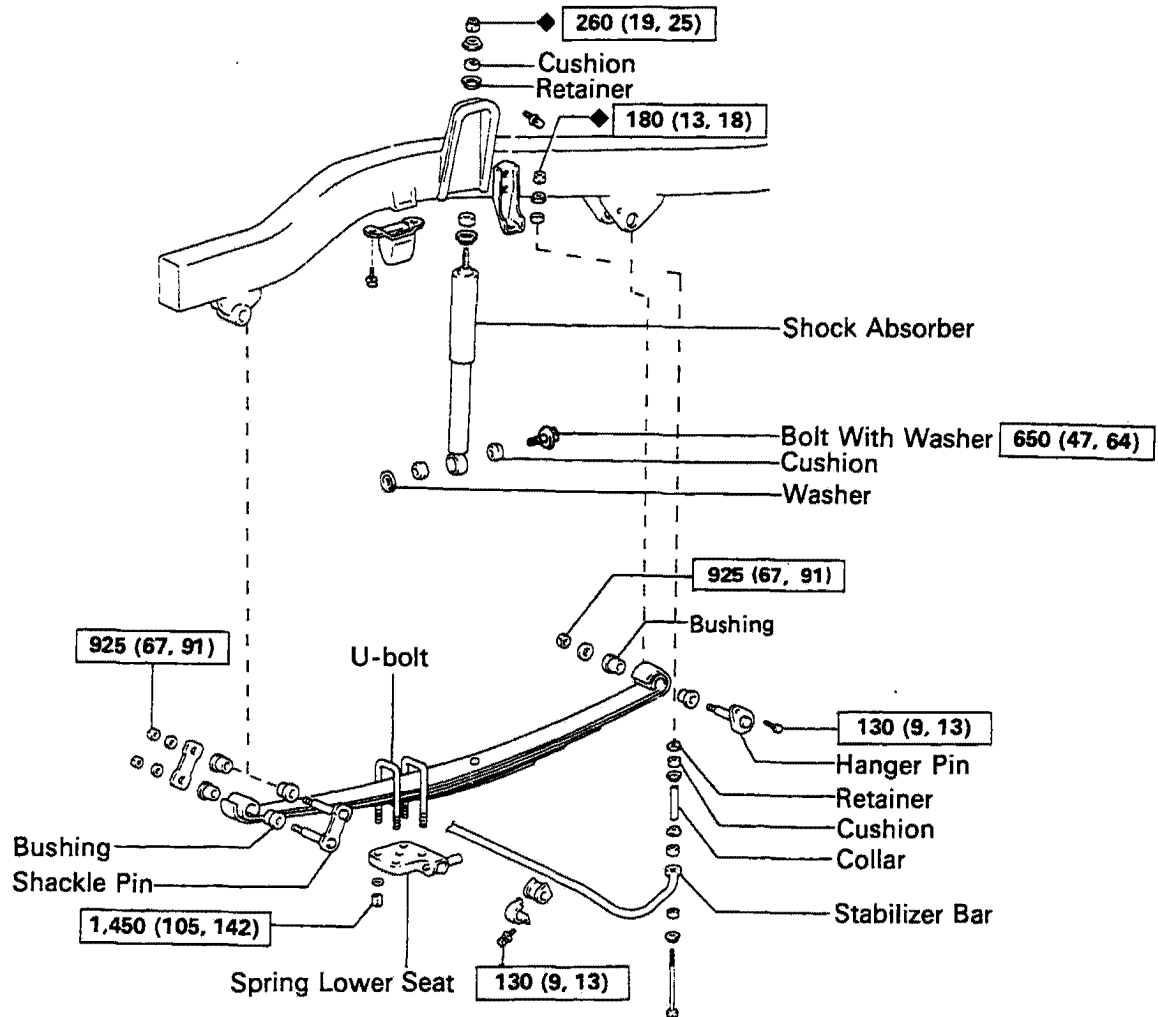

### Leaf Spring Component

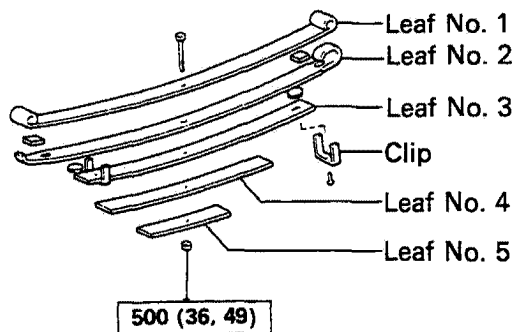

kg-cm (ft-lb, N-m) : Tightening torque

◆ Non-reusable part

- MEMO -

---

# REAR AXLE AND SUSPENSION

REFER TO LAND CRUISER (Heavy-Duty) REPAIR  
MANUAL FOR CHASSIS AND BODY  
(Pub. No. 36262E)

NOTE: The following pages contain only the points which  
differ from the above listed manual.

	Page
REAR AXLE SHAFT (Semi-floating Type) ...	RA-2
REAR SUSPENSION .....	RA-3

# REAR AXLE SHAFT (Semi-floating Type)

For removal, installation of the rear axle shaft, refer to the repair manual chassis and body LAND CRUISER (Heavy-Duty) Pub. No. 36262E.

## COMPONENTS

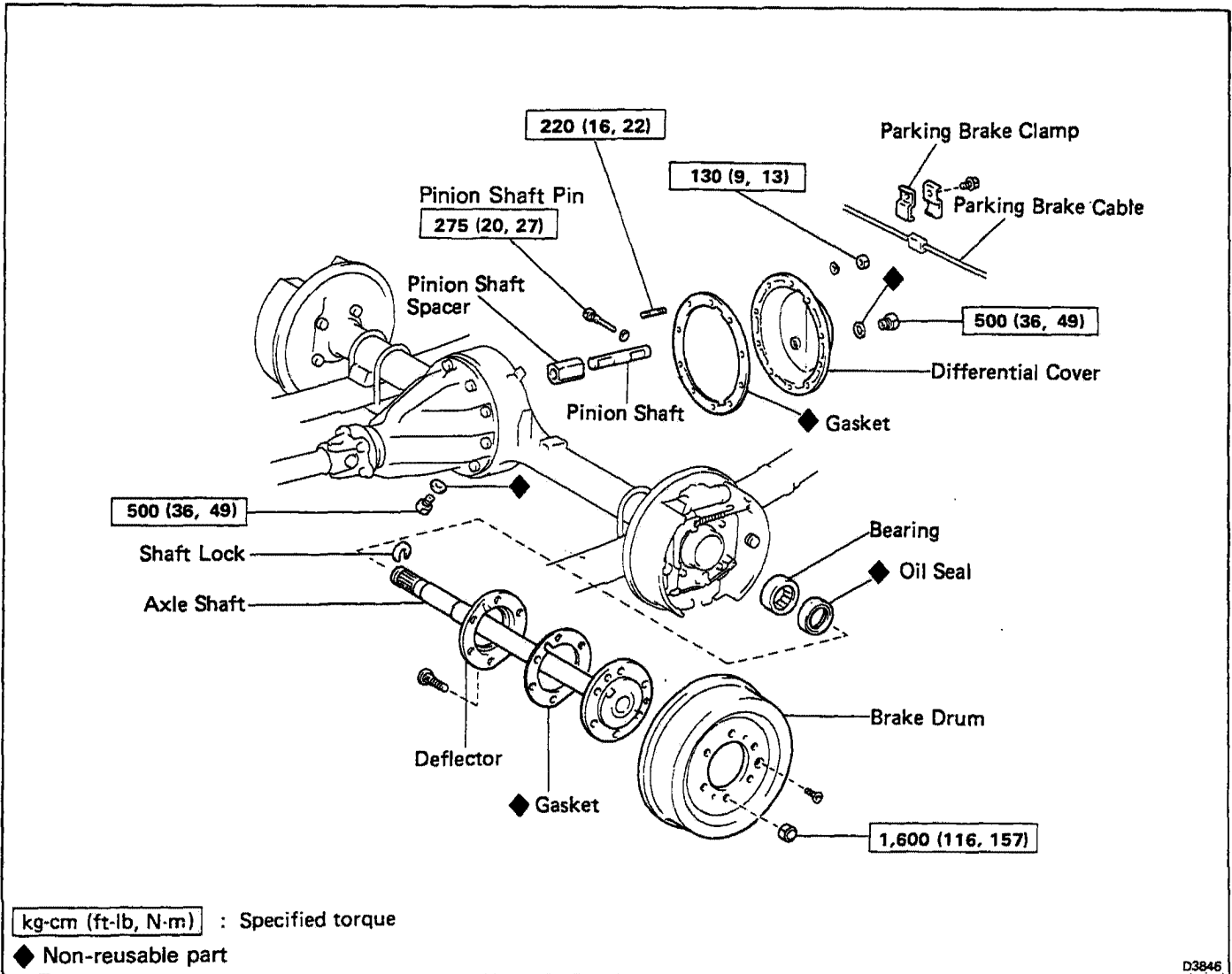

# REAR SUSPENSION COMPONENTS

FJ 62 series

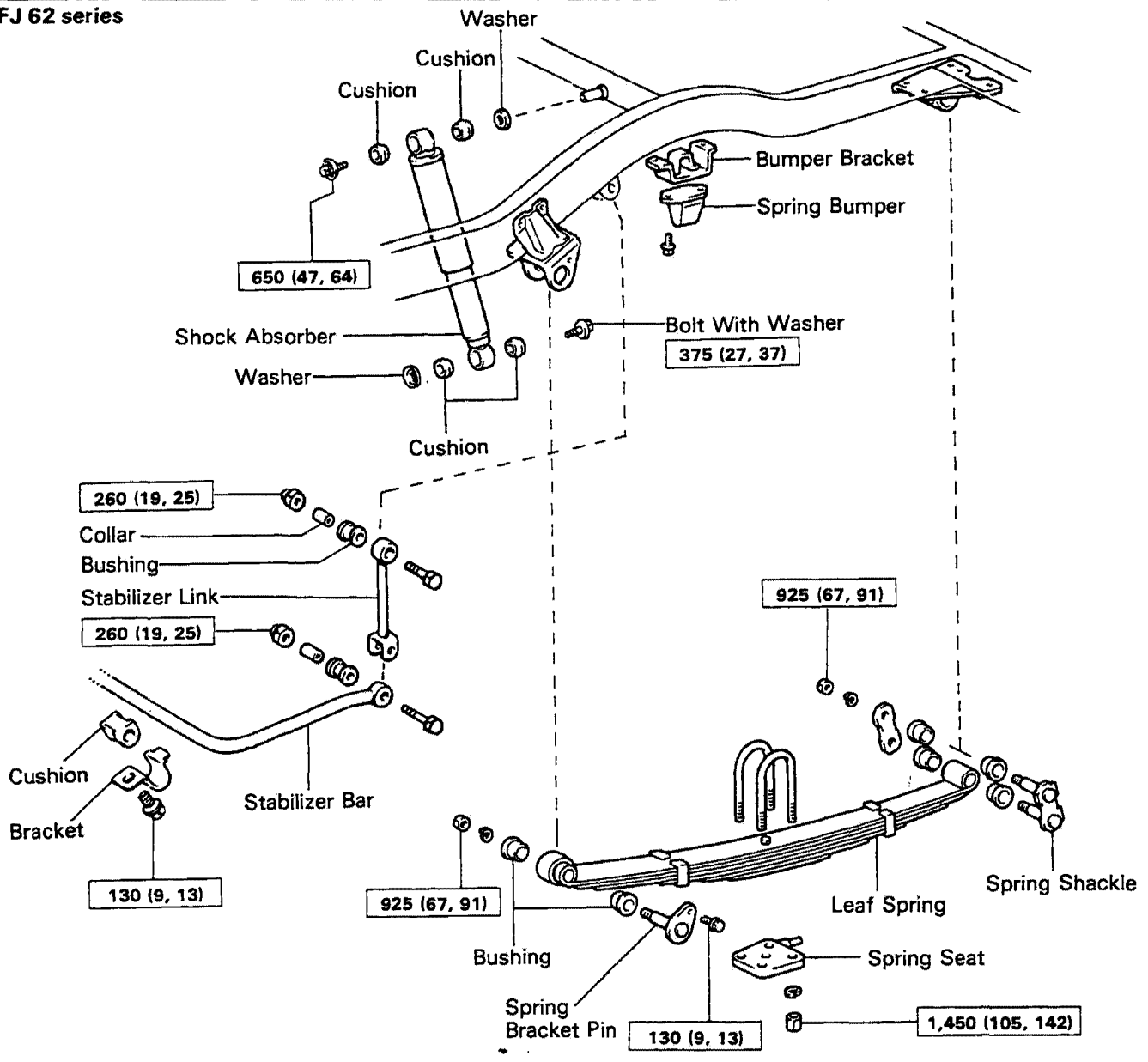

## Leaf Spring Component

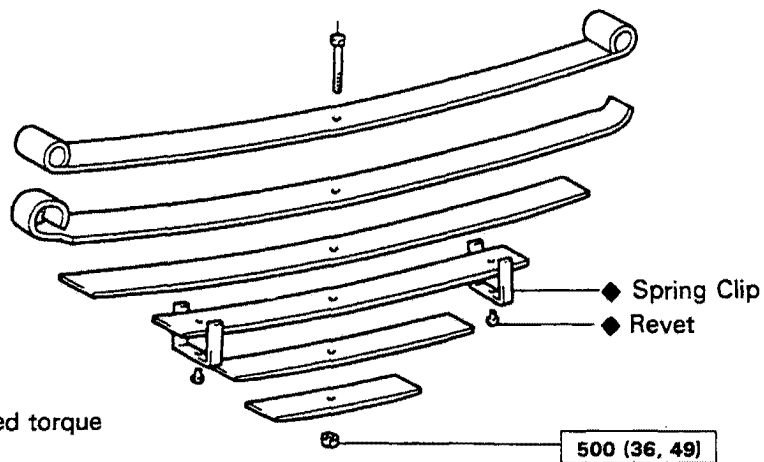

kg-cm (ft-lb, N-m) : Specified torque

◆ Non-reusable part

- MEMO -

---

---

# BRAKE SYSTEM

REFER TO LAND CRUISER (Heavy-Duty) REPAIR  
MANUAL FOR CHASSIS AND BODY  
(Pub. No. 36262E)

NOTE: The following pages contain only the points which  
differ from the above listed manual.

	<b>Page</b>
<b>CHECKS AND ADJUSTMENTS .....</b>	<b>BR-2</b>
<b>FRONT BRAKE .....</b>	<b>BR-2</b>
<b>LOAD SENSING PROPORTIONING VALVE ..</b>	<b>BR-2</b>

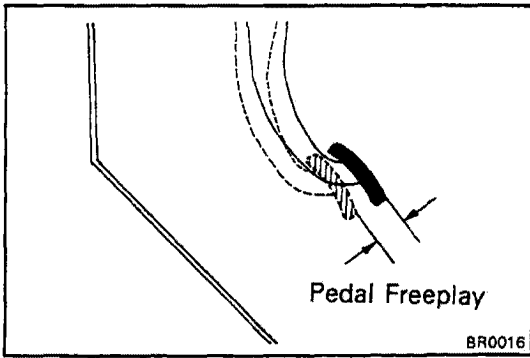

## CHECKS AND ADJUSTMENTS

### CHECK PEDAL FREEPLAY

- (a) Stop the engine and depress the brake pedal several times until there is no more vacuum left in the booster.
- (b) Push in the pedal by hand until the beginning of the second resistance is felt, measure the distance, as shown.

**Pedal freeplay: 3 – 6 mm (0.12 – 0.24 in.)**

**NOTE:** The freeplay to the first resistance is due to the play between the clevis and pin. And it is 1 – 3 mm (0.04 – 0.12 in.) on the pedal.

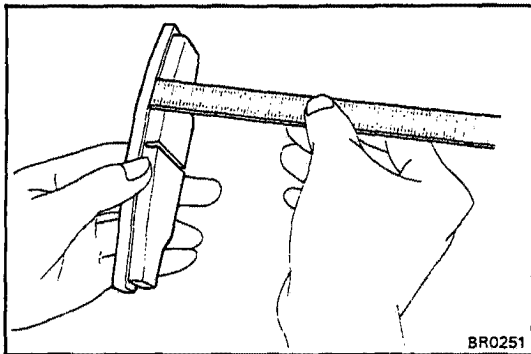

## FRONT BRAKE

### PAD LINING THICKNESS

Minimum thickness:

Previous 1.0 mm (0.039 in.)



New 4.0 mm (0.157 in.)

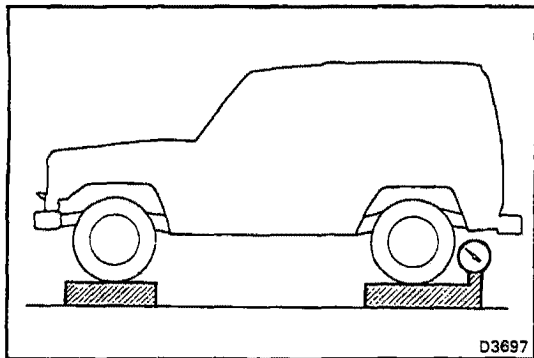

## LOAD SENSING PROPORTIONING VALVE

### SET REAR AXLE LOAD

Rear axle load (include vehicle weight):

Previous 1,200 kg (2,646 lb)



New 1,100 kg (2,425 lb)

# BODY ELECTRICAL SYSTEM

REFER TO LAND CRUISER (Heavy-Duty) REPAIR  
MANUAL FOR CHASSIS AND BODY  
(Pub. No. 36262E)

NOTE: The following pages contain only the points which  
differ from the above listed manual.

	<b>Page</b>
REAR WIPER AND WASHER .....	<b>BE-2</b>
COMBINATION METER .....	<b>BE-5</b>
REAR HEATER .....	<b>BE-8</b>

# REAR WIPER AND WASHER Troubleshooting

Problem	Possible cause	Remedy	Page
Wiper do not operate or return to off position	WIPER fuse blown	Replace fuse and check for short	BE-3
	Wiper motor faulty	Check motor	BE-3
	Wiper switch faulty	Check switch	BE-3
	Wiper relay faulty	Check relay	BE-3
	Wiring or ground faulty	Repair as necessary	
Wiper do not operate in INT position	Wiper relay faulty	Check relay	BE-3
	Wiper control relay faulty	Check relay	BE-3
	Wiper motor faulty	Check motor	BE-3
	Wiring or ground faulty	Repair as necessary	
Washer does not operate	Washer hose or nozzle clogged	Repair as necessary	BE-3
	Washer motor faulty	Check motor	
	Wiper switch faulty	Check switch	
	Wiring or ground faulty	Repair as necessary	

## Wiring Diagram

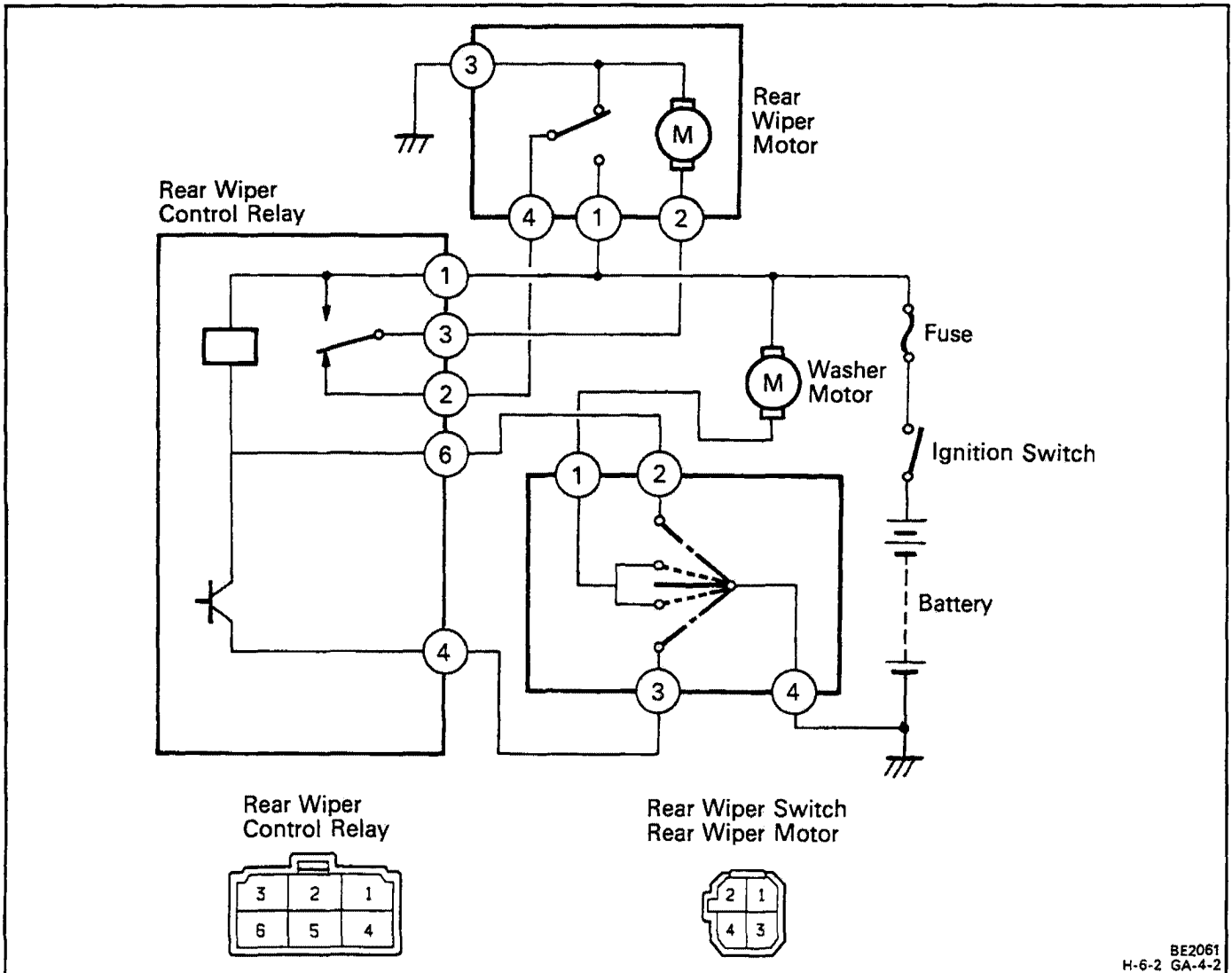

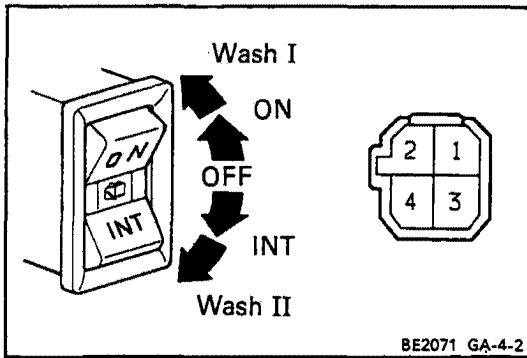

## Rear Wiper and Washer Switch

### INSPECT SWITCH CONTINUITY

Inspect the continuity between terminals for each switch position.

Terminal Switch position	1	2	4	3
Washer II	○—	○—	○—	
INT		○—	○—	
OFF				
ON			○—	○—
Washer I	○—	○—	○—	○—

If continuity is not as specified, replace the switch.

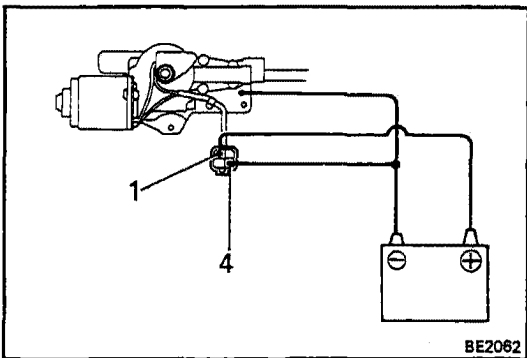

## Rear Wiper Motor

### 1. INSPECT MOTOR OPERATES

- (a) Connect the positive (+) lead from the battery to terminal 1 and the negative (-) leads to both terminal 4 and motor body.
- (b) Check that the motor operates.

### 2. INSPECT INTERMITTENT OPERATION

- (a) Connect the positive (+) lead from the battery to terminal 1 and the negative (-) leads to both terminal 2 and motor body.
- (b) Check that the motor operates intermittently for 10 – 15 seconds.

If operation is not as specified, check that the rear wiper control relay.

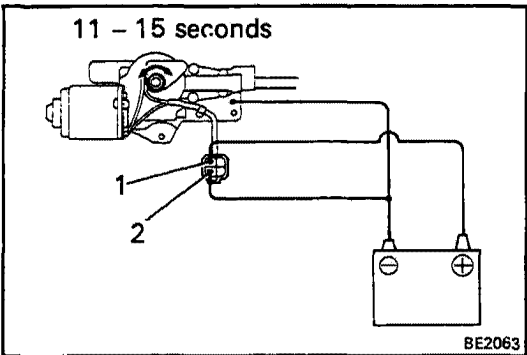

### 3. INSPECTION MOTOR OPERATES, STOPPING AT STOP POSITION

- (a) Start motor operation by connecting the positive (+) lead from the battery to terminal 1 and the negative (-) leads to both terminal 4 and motor body.
- (b) Stop motor operation anywhere except stop position by disconnecting terminal 1.

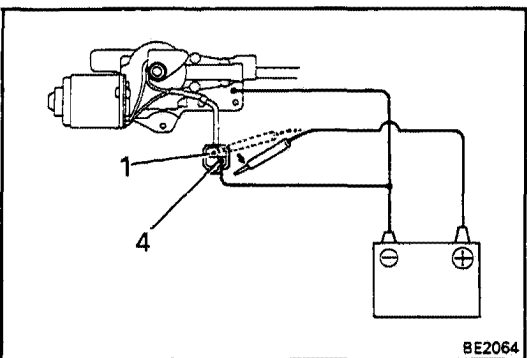

- (c) Connect the positive (+) lead from the battery to terminal 1 and the negative (-) lead to the motor body.
- (d) Check that the motor stops running at the off position after the motor operates again.

If operation is not as specified, replace the motor.

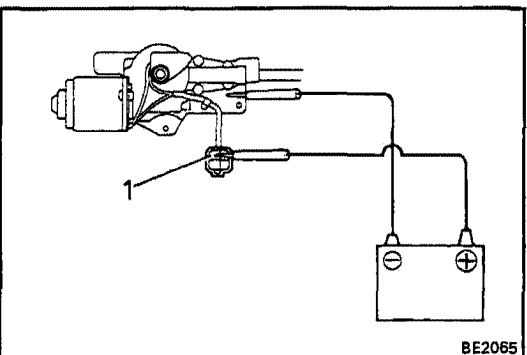

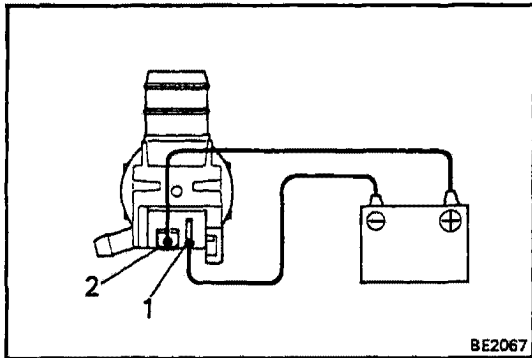
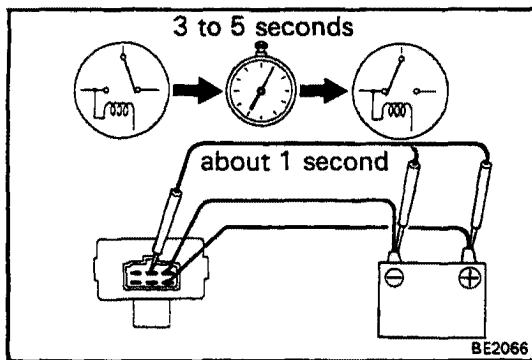

## Rear Wiper Control Relay

### INSPECT RELAY OPERATION

- With terminal 1 connected to the battery position (+) terminals. Check that there is a relay operation noise when terminal 4 is connected to the battery negative (-) terminal.
- Connect terminal 2 to the battery positive (+) terminal.
- Check that there is a relay operation noise when changing terminal 2 to the battery negative (-) terminal and another operation noise 3 to 5 seconds later.

If operation is not as specified, replace the relay.

## Rear Washer Motor

Connect the positive (+) lead from the battery to terminal 2 and the negative (-) lead to terminal 1, check that the motor operation.

**CAUTION:** These tests must be performed quickly (within 20 seconds) to prevent the coil from burning out.

If operation is not as specified, replace the motor.

# Combination Meter

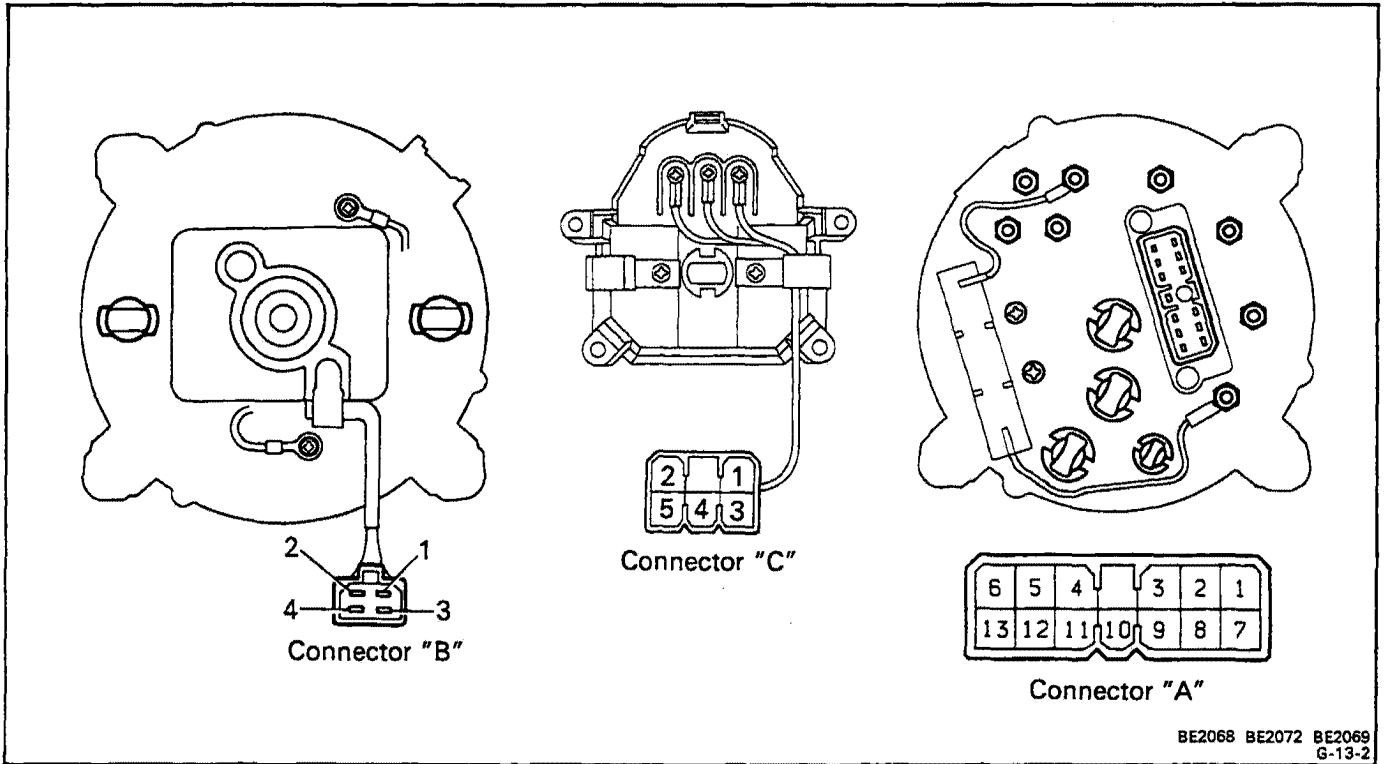

BE2068 BE2072 BE2069  
G-13-2

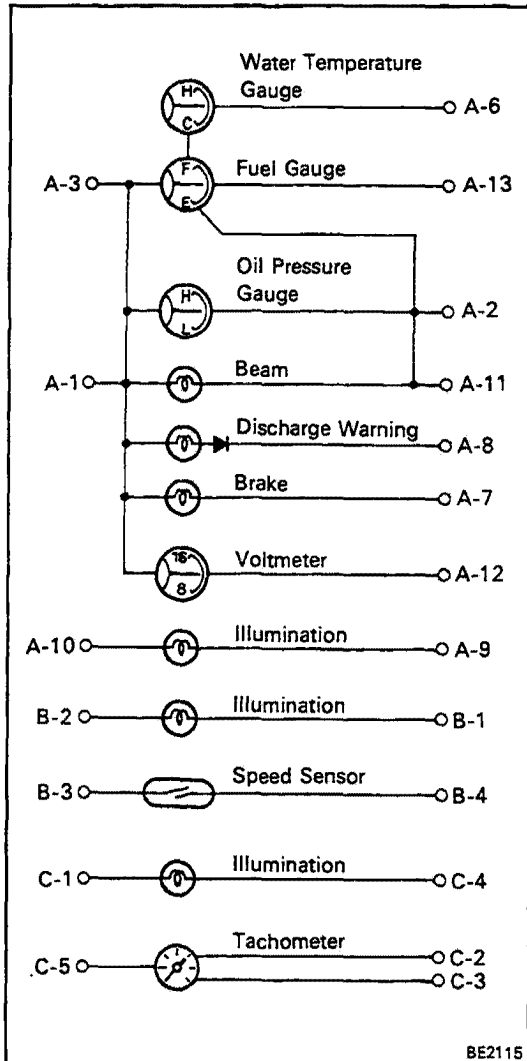

BE2115

## COMBINATION METER CIRCUIT

Connector	Terminal	Wiring Connector Side
A	1	Hi-Beam indicator
	2	Oil Pressure Sender Gauge
	3	GAUGE Fuse
	4	—
	5	—
	6	Water Temperature Sender Gauge
	7	Parking Brake Switch and Brake Fluid Level Warning Switch
	8	CHARGE Fuse
	9	Ground
	10	TAIL Fuse
	11	Ground
	12	Ground
	13	Fuel Sender Gauge
B	1	TAIL Fuse
	2	Ground
	3	Emission Computer
	4	Ground
C	1	TAIL Fuse
	2	Ignition Coil
	3	Ground
	4	Ground
	5	GAUGE Fuse

## Speedometer System

### INSPECT SPEEDOMETER (ON-VEHICLE)

- (a) Using a speedometer tester, inspect the speedometer for allowable indication error and check the operation of the odometer.

NOTE: Tire wear and tire over or under inflation will increase the indication error.

Standard indication (km/h)	Allowable range (km/h)
20	18 – 23
40	40 – 44
60	60 – 64.5
80	80 – 85
100	100 – 105
120	120 – 125.5
140	140 – 146
160	160 – 167

Standard indication (mph)	Allowable range (mph)
20	20 – 23
40	40 – 43.5
60	60 – 64
80	80 – 84.5
100	100 – 105

If error is excessive, replace the speedometer.

- (b) Check the speedometer for pointer vibration and abnormal noise.

NOTE: Pointer vibration can be caused by a loose speedometer cable.

## Tachometer System

### INSPECT TACHOMETER (ON-VEHICLE)

- (a) Connect a tune-up test tachometer, and start the engine.

#### CAUTION:

- Reversing the connection of the tachometer will damage the transistors and diodes inside.
- When removing or installing the tachometer, be careful not to drop or subject it to heavy shocks.

- (b) Compare the tester and tachometer indications.

rpm	1000	2000	3000	4000
Temp. and volts				
20°C DC13V	±100	±125	±150	±150

If error is excessive, replace the tachometer.

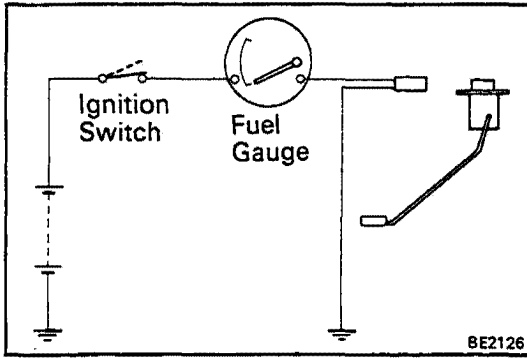

## Fuel Gauge System

### 1. INSPECT RECEIVER GAUGE OPERATION

- (a) Disconnect the connector from the sender gauge.
- (b) Turn the ignition switch ON, check that the receiver gauge needle indicates the empty.

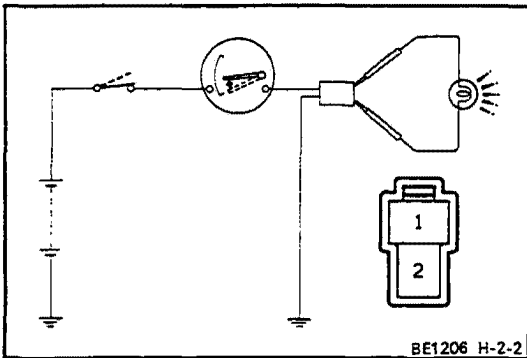

- (c) Connect the terminals 3 and 4 on the wire harness side connector through a 3.4 W test bulb.
- (d) Turn the ignition switch ON, check that the bulb lights and receiver gauge needle moves towards the full side.

If operation is not as specified, inspect the receiver gauge resistance and voltage regulator.

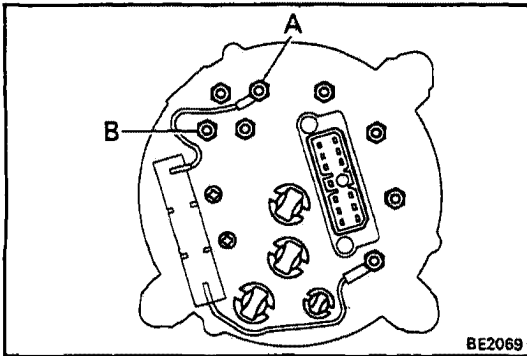

### 2. MEASURE RECEIVER GAUGE RESISTANCE

Measure the resistance between terminals A and B.

**Resistance: Approx. 55 Ω**

If resistance value is not as specified, replace the receiver gauge.

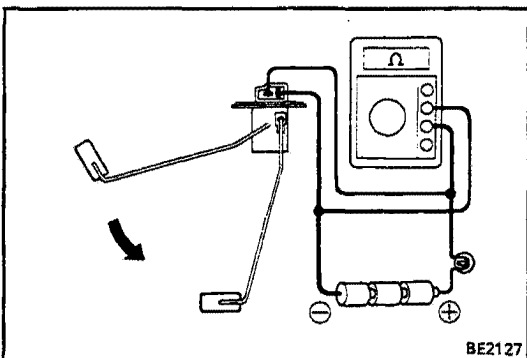

### 3. INSPECT SENDER GAUGE OPERATION

- (a) Connect a series of three 1.5 V dry cell batteries.
- (b) Connect the positive (+) lead from the dry cell battery to terminal 1 through a 3.4 W test bulb and the negative (-) lead to terminal 2.
- (c) Check that the voltage rises between terminals 1 and 2 as the float is moved from the top to bottom position.
- (d) Measure the resistance between terminals 1 and 2 for each float position.

Float position	mm (in.)	Resistance (Ω)
F	Approx. 34.5 (1.36)	Approx. 3.0 ± 2.1
E	Approx. 160.5 (6.32)	Approx. 110 ± 6.5

If resistance value is not as specified, replace the sender gauge.

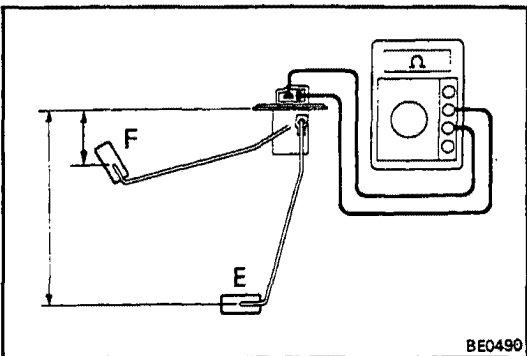

# REAR HEATER

## Troubleshooting

Problem	Possible cause	Remedy	Page
Blower does not work when fan switch on	Heater relay faulty	Check relay	BE-8
	Heater blower switch faulty	Check switch	BE-8
	Heater blower resistor faulty	Check resistor	BE-9
	Heater blower motor faulty	Replace motor	
	Wiring or ground faulty	Repair as necessary	
Incorrect temperature output	Heater hose leaking or clogged Heater radiator leaking or clogged	Replace hose Replace radiator	

## Wiring Diagram

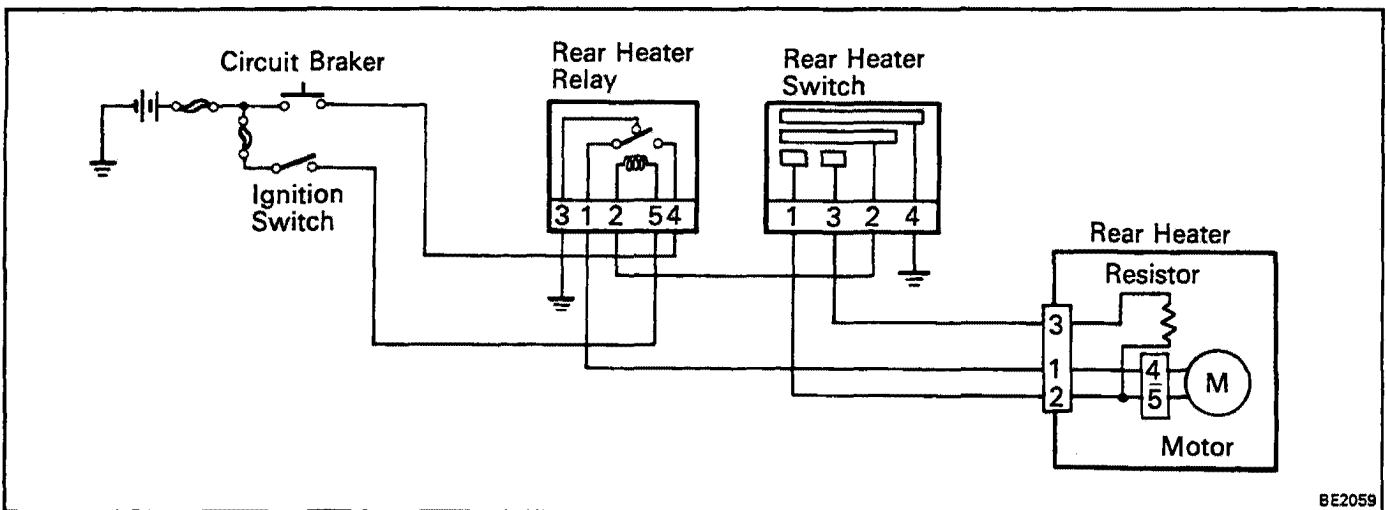

BE2059

## Rear Heater Blower Switch

### INSPECT SWITCH CONTINUITY

Inspect the switch continuity between terminals.

Terminal	1	2	3	4
Switch position				
HI	○	○		○
OFF				
LO		○	○	○

If continuity is not as specified, replace the switch.

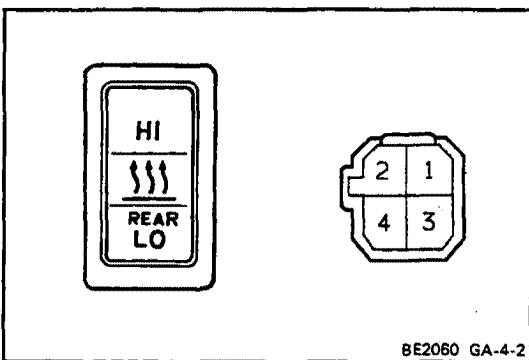

BE2060 GA-4-2

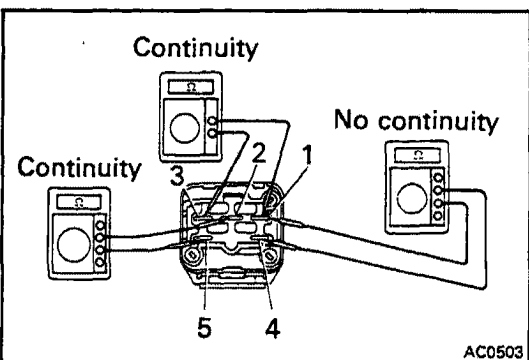

AC0503

## Rear Heater Relay

### 1. INSPECT RELAY CONTINUITY

- Check that there is continuity between terminals 1 and 3.
- Check that there is continuity between terminals 2 and 5.
- Check that there is no continuity between terminals 1 and 4.

If continuity is not as specified, replace the relay.

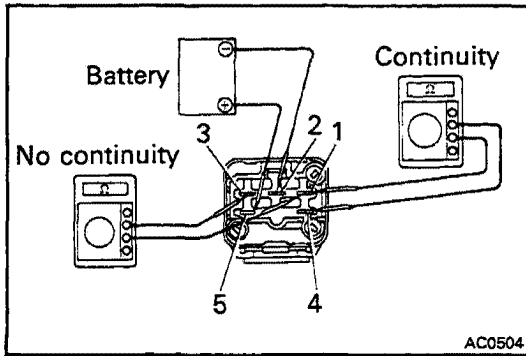

## 2. INSPECT RELAY OPERATION

- Apply battery voltage to terminals 2 and 5.
- Check that there is continuity between terminals 1 and 4.
- Check that there is no continuity between terminals 1 and 3.

If operation is not as specified, replace the relay.

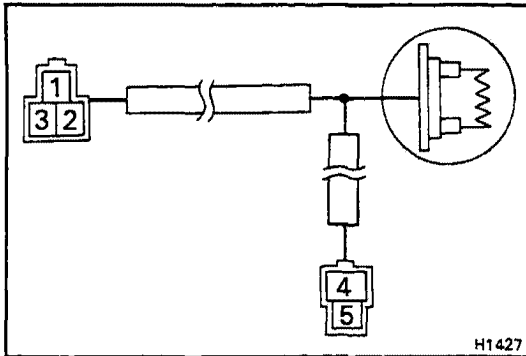

## Rear Heater Blower Resistor

### INSPECT RESISTOR CONTINUITY

- Check that there is continuity between terminals 1 and 4.
- Check that there is continuity between terminals 2 and 3.
- Check that there is continuity between terminals 3 and 5.

If continuity is not as specified, replace the resistor.

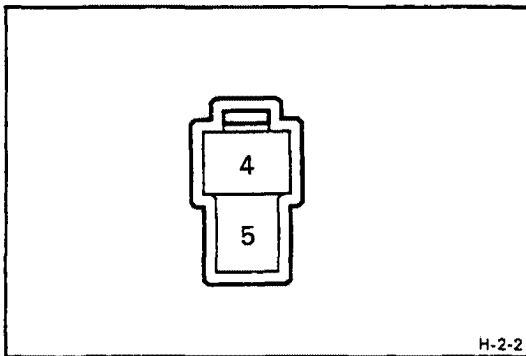

## Rear Heater Blower Motor

### INSPECT MOTOR OPERATION

- Connect the positive (+) lead from the battery to terminal 4 and the negative (-) lead to terminal 5.
- Check that the motor operation.

If operation is not as specified, replace the motor.

- MEMO -

---

---

# BODY

**REFER TO LAND CRUISER (Heavy-Duty) REPAIR  
MANUAL FOR CHASSIS AND BODY  
(Pub. No. 36262E)**







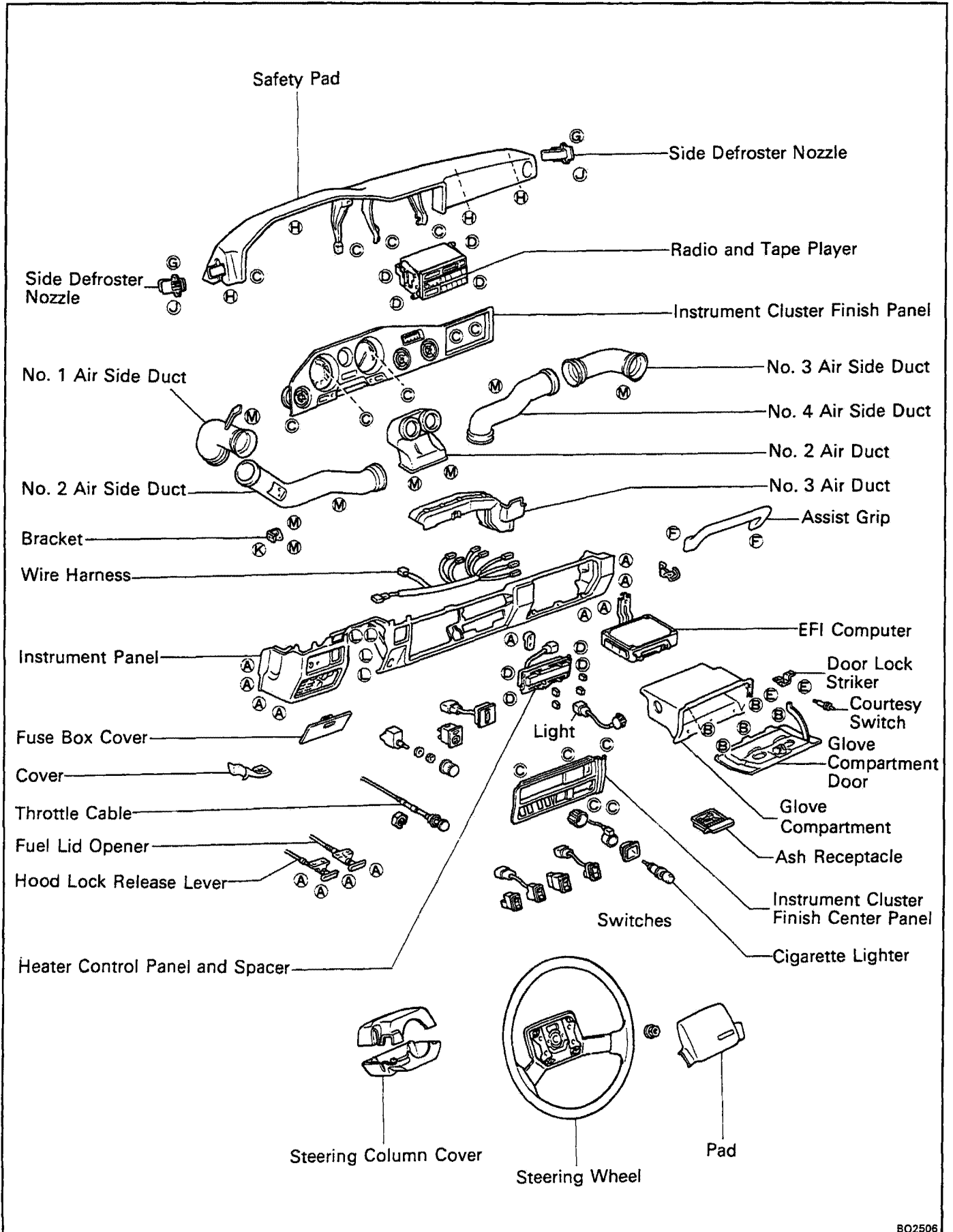

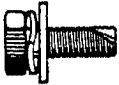

NOTE: The following pages contain only the points which differ from the above listed manual.

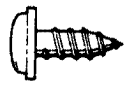
	<b>Page</b>
<b>INSTRUMENT PANEL .....</b>	<b>BO-2</b>

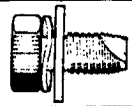
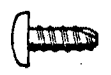
# INSTRUMENT PANEL COMPONENTS

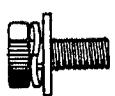

NOTE: Screw sizes in the previous illustration are indicated by following the code below for removal and installation of instrument panel.

Code	Shape	Code	Shape	Code	Shape
A	 $\phi = 6$ $L = 16$	F	 $\phi = 8$	K	 $\phi = 6$ $L = 16$
B	 $\phi = 5$ $L = 16$	G	 $\phi = 5$ $L = 16$	L	 $\phi = 8$ $L = 16$
C	 $\phi = 5$ $L = 16$	H	 $\phi = 6$	M	 $\phi = 5$ $L = 12$
D	 $\phi = 5$ $L = 25$	I	 $\phi = 6$ $L = 14$	N	
E	 $\phi = 5$ $L = 16$	J	 $\phi = 5$ $L = 20$	—	—

BO1109

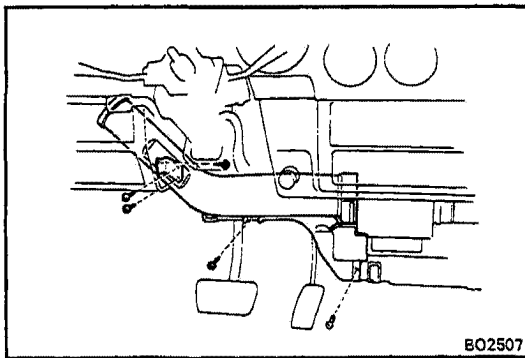

BO2507

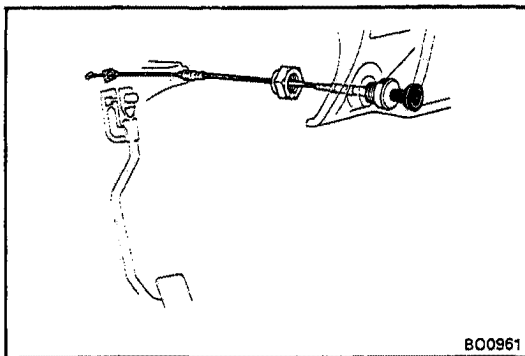

BO0961

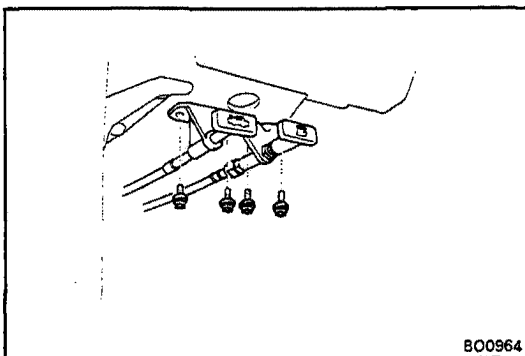

BO0964

## REMOVAL OF INSTRUMENT PANEL

1. **DISCONNECT BATTERY CABLE FROM NEGATIVE TERMINAL**
2. **REMOVE STEERING WHEEL**
3. **REMOVE STEERING COLUMN COVER**
4. **REMOVE NO. 2 AIR SIDE DUCT AND NO. 3 AIR DUCT**
  - (a) Remove four screws, bracket and No. 2 air side duct.
  - (b) Remove the clip and No. 3 air duct.
5. **REMOVE THROTTLE CABLE**
  - (a) Disconnect the throttle cable from accelerator pedal and retainer.
  - (b) Remove the throttle cable set nut and throttle cable.
6. **HOOD LOCK RELEASE LEVER AND FUEL LID OPENER**
  - (a) Remove two bolts and hood lock release lever.
  - (b) Remove two bolts and fuel lid opener.

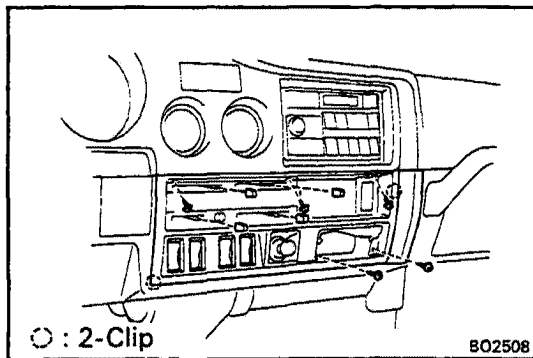

### 7. REMOVE INSTRUMENT CLUSTER FINISH CENTER PANEL

- (a) Remove four heater control lever knobs.
- (b) Remove the ash receptacle, five screws and loose two clips.
- (c) Remove the instrument cluster finish center panel.
- (d) Disconnect the connectors.

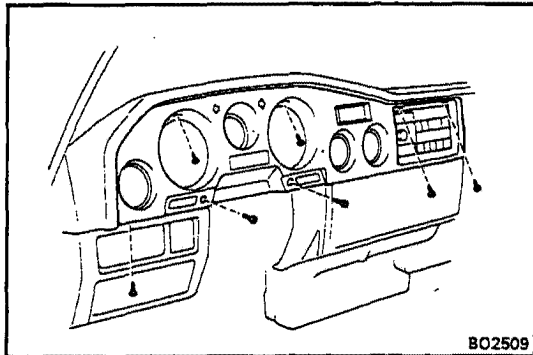

### 8. REMOVE INSTRUMENT CLUSTER FINISH PANEL

- (a) Remove seven screws.
- (b) Remove the instrument cluster finish panel.
- (c) Disconnect the speedometer cable.
- (d) Disconnect the connectors.

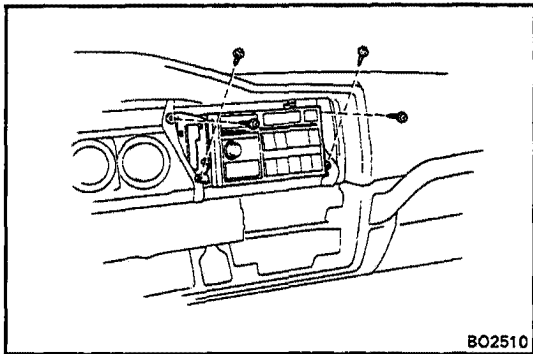

### 9. REMOVE RADIO AND TAPE PLAYER

- (a) Remove four screws and radio with tape player.
- (b) Disconnect the connectors and antenna code.

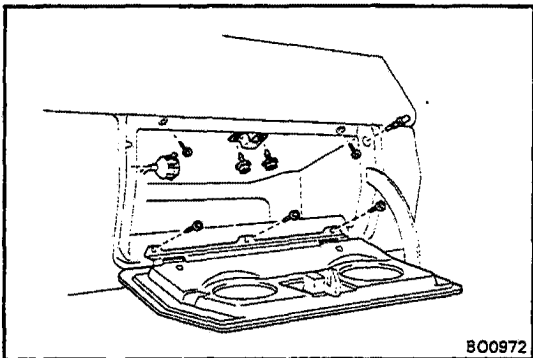

### 10. REMOVE GLOVE COMPARTMENT

- (a) Remove three screws and glove compartment door.
- (b) Remove the courtesy switch and illumination light.
- (c) Remove four screws, door lock striker and glove compartment.

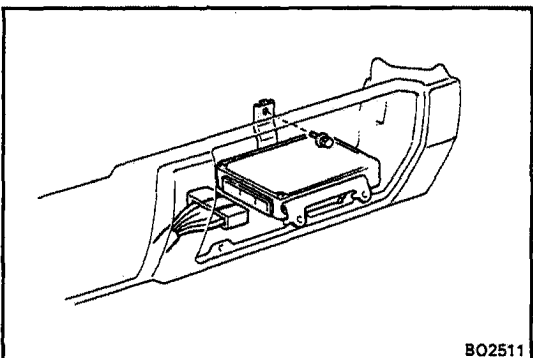

### 11. REMOVE EFI COMPUTER

- (a) Remove the bolt and EFI computer.
- (b) Disconnect the EFI computer connectors.

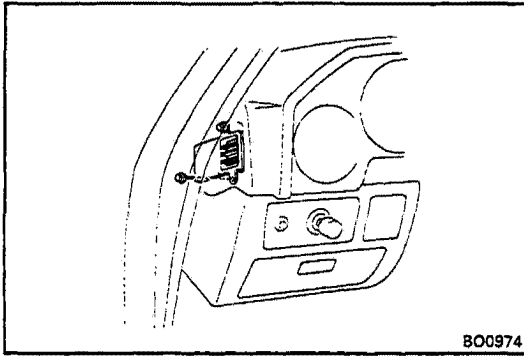

## 12. REMOVE NO. 1, NO. 3 AND NO. 4 AIR SIDE DUCTS

- (a) Remove the screw and No. 1 air side duct.
- (b) Remove the screw and No. 3 air side duct.
- (c) Remove the screw and No. 4 air side duct.

## 13. REMOVE LOWER SIDE DEFROSTER NOZZLE SET SCREW

- (a) Remove the lower side screw only.
- (b) Disconnect the side defroster nozzle hose.

## 14. REMOVE SAFETY PAD

- (a) Remove four screws and four nuts.
- (b) Loosen two clips and remove the safety pad to rearward.

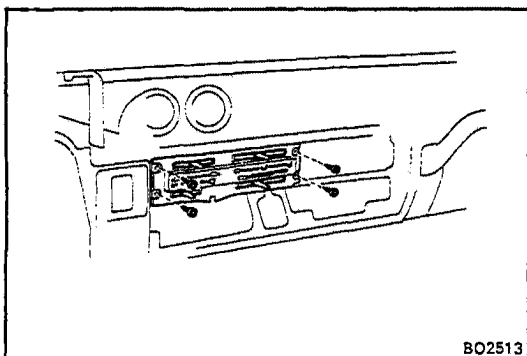
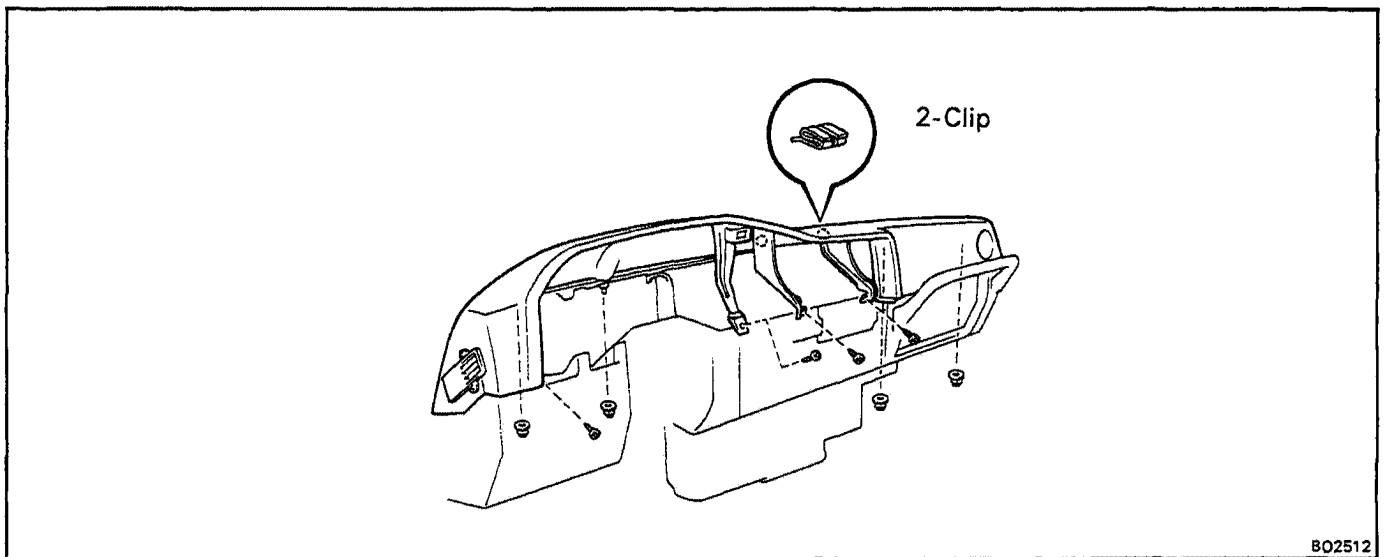

## 15. REMOVE HEATER CONTROL PANEL AND NO. 2 AIR DUCT

- (a) Remove four screws, heater control panel and spacer.
- (b) Disconnect the connectors.
- (c) Remove two screws and No. 2 air duct.
- (d) Push in the remaining heater control to forward.

## 16. REMOVE MIRROR CONTROL SWITCH, RHEOSTAT AND 4WD CONTROL CONNECTORS

## 17. REMOVE FUSE BOX AND COVER

Remove the fuse box cover and two bolts.

## 18. REMOVE TWO STEERING POST UPPER SIDE MOUNTING BOLTS

**19. REMOVE INSTRUMENT PANEL**

- (a) Remove fifteen bolts and instrument panel to rearward.

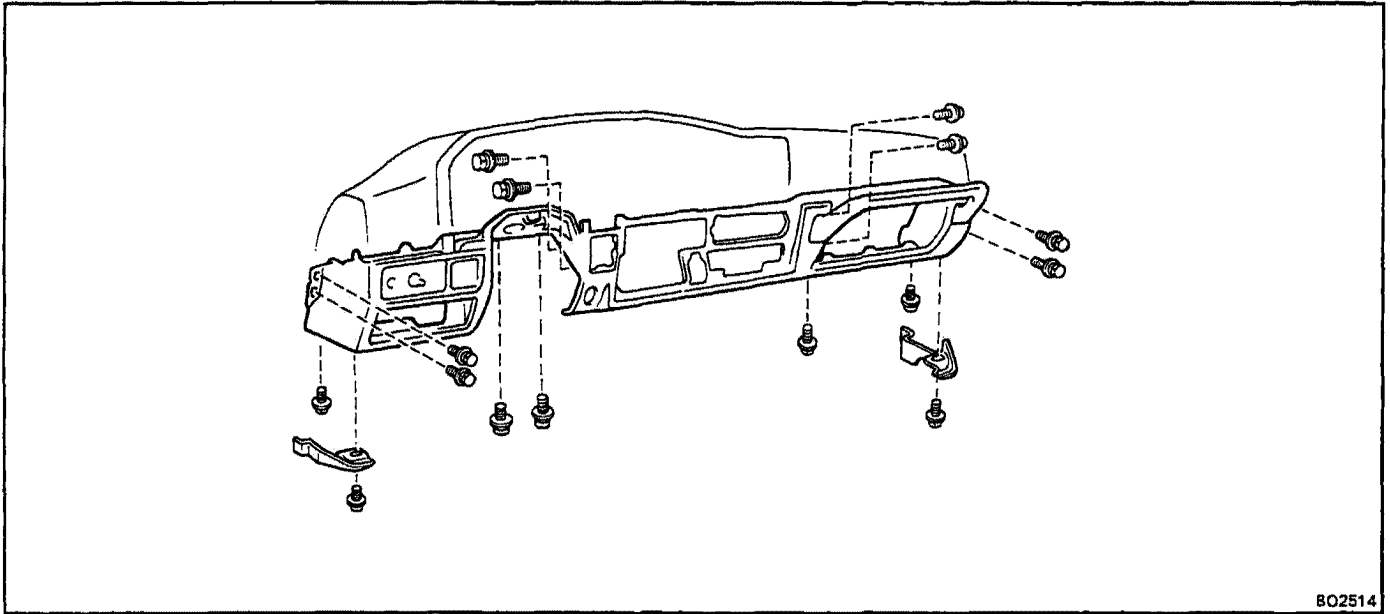
**20. REMOVE FOLLOWING PARTS AS NECESSARY**

- Side defroster nozzle
- Switches
- Rheostat
- Assist grip
- Wire harness etc.

**INSTALLATION OF INSTRUMENT PANEL**

**INSTALL PARTS OF INSTRUMENT PANEL IN  
REVERSE SEQUENCE OF REMOVAL**

# AIR CONDITIONING SYSTEM

**REFER TO REPAIR MANUAL CHASSIS & BODY**

**LAND CRUISER Pub. No. 36262E**

**NOTE:** The following pages contain only the points which differ from above listed manual

<b>SPECIAL TOOLS AND EQUIPMENT .....</b>	<b>AC-2</b>
<b>AIR CONDITIONING SYSTEM CIRCUIT .....</b>	<b>AC-2</b>
<b>COMPRESSOR .....</b>	<b>AC-3</b>
<b>AIR CONDITIONER AMPLIFIER .....</b>	<b>AC-13</b>

# SPECIAL TOOLS AND EQUIPMENT

Tool	SST No.	Use
Manifold gauge set	07710-58011	To evacuate and charge system
Ohmmeter	—	To diagnosis electrical system
Voltage meter	—	To diagnosis electrical system
Magnet clutch stopper	07112-76040	To remove and install pressure plate
Magnet clutch tool set	07110-77011	Includes the following 8 tools
Pressure plate remover	07112-71010	To remove pressure plate
Snap ring pliers	07114-84020	To remove and install snap ring
Key remover	07112-45021	To remove key
Shaft plate remove	07112-15010	To remove shaft plate
Shaft plate installing tool	07114-15010	To install shaft plate
Hexagon wrench set	07110-61050	To remove and install service valves and front housing
Shaft Seal tool	07112-25010	To remove and install shaft seal
Key press tool	07114-45010	To install key

# AIR CONDITIONING SYSTEM CIRCUIT

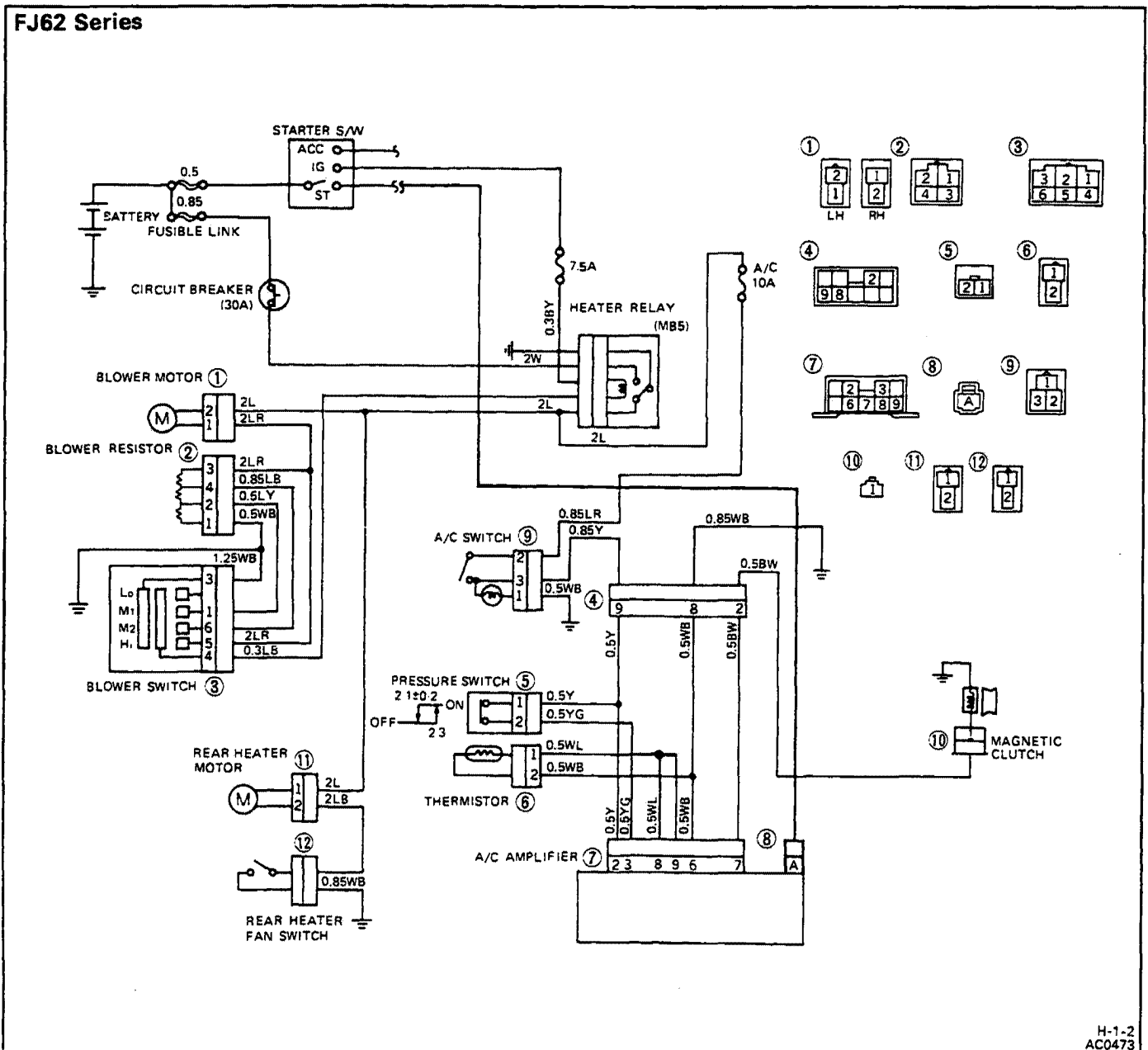

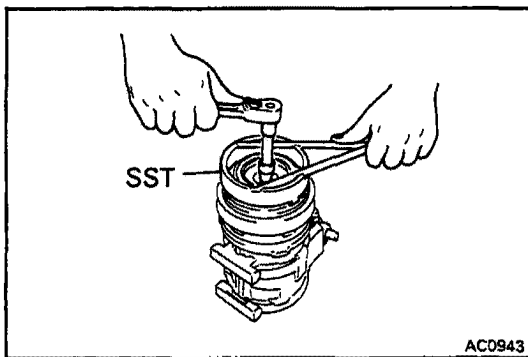
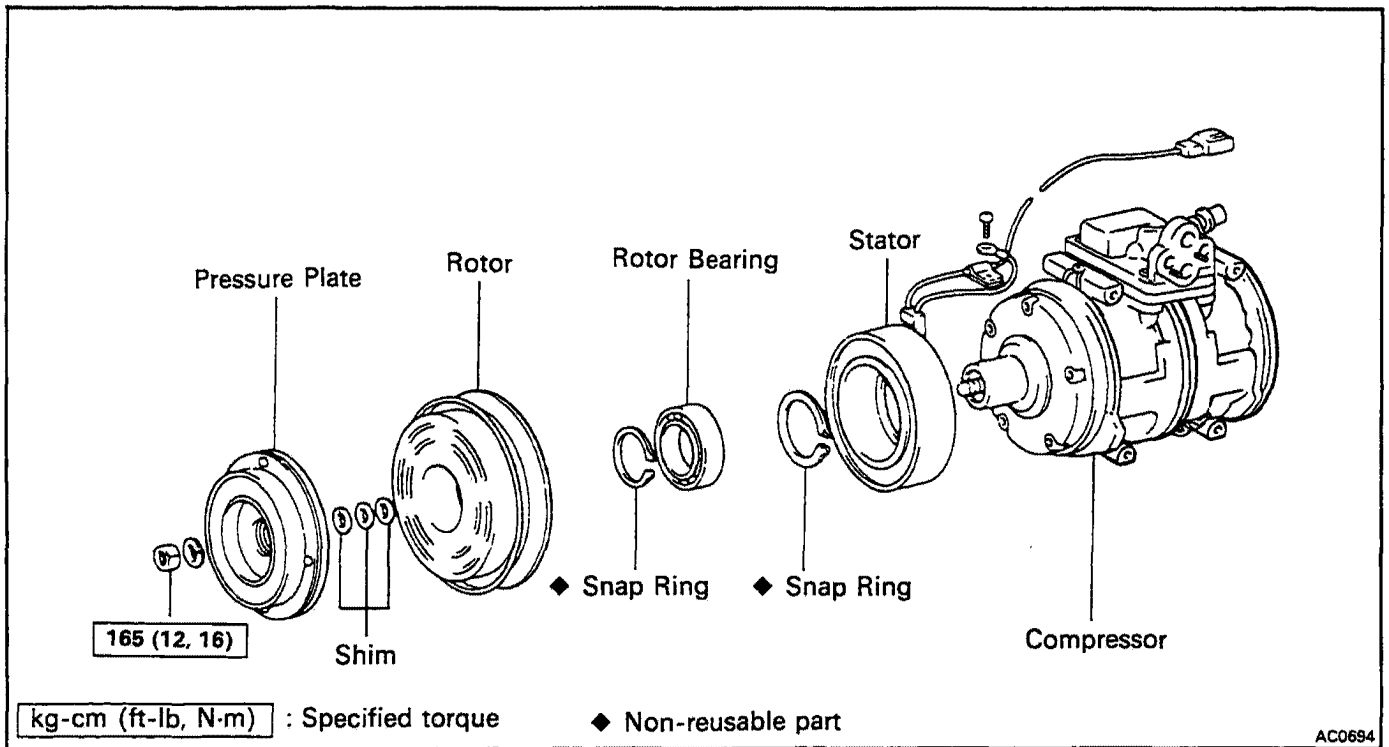

## DISASSEMBLY OF MAGNETIC CLUTCH

### 1. REMOVE PRESSURE PLATE

(a) Using SST and socket, remove the shaft nut.  
SST 07112-76040

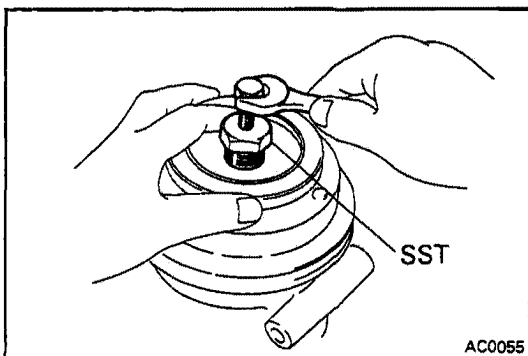

(b) Using SST and socket, remove the pressure plate.  
SST 07112-71010

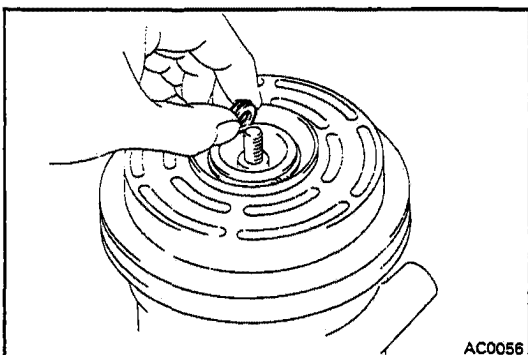

(c) Remove the shims from the shaft.

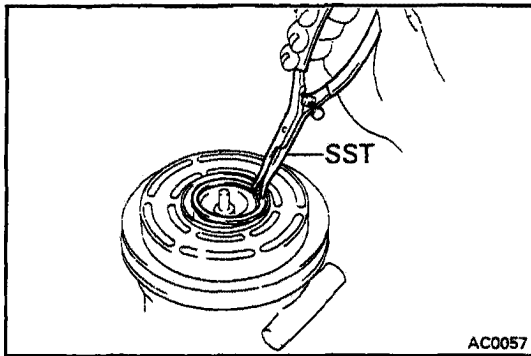

## 2. REMOVE ROTOR

- (a) Using SST, remove the snap ring.  
SST 07114-84020

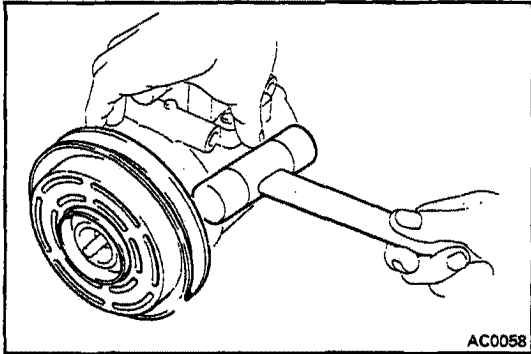

- (b) Using a plastic hammer, tap the rotor off the shaft.  
**CAUTION:** Be careful not to damage the pulley when tapping on the rotor.

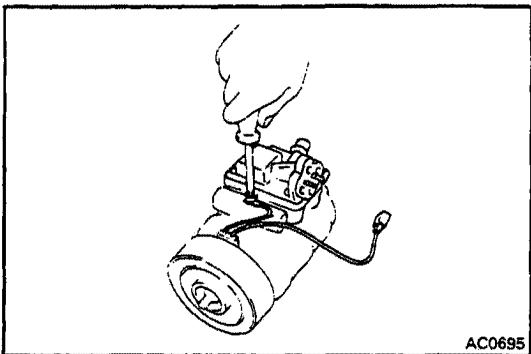

## 3. REMOVE STATOR

- (a) Disconnect the stator lead wires from the compressor housing.

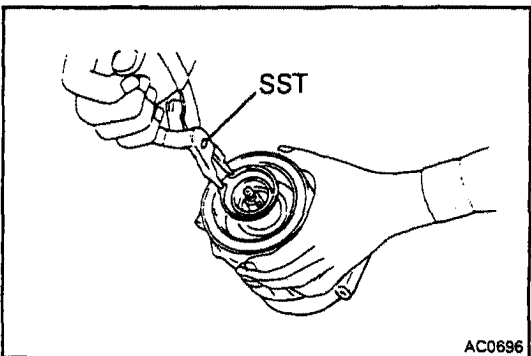

- (b) Using SST, remove the snap ring. Remove the stator.  
SST 07114-84020

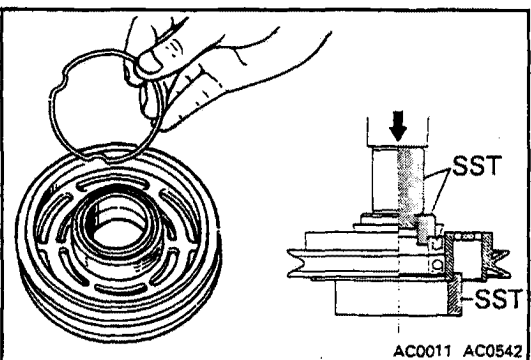

## 4. REMOVE ROTOR BEARINGS

NOTE: Press out the bearings only if they are to be replaced.

- (a) Remove the bearing snap ring from the rotor  
(b) Using SST, press out the two bearings.  
SST 07110-77011

## 5. INSPECT PRESSURE PLATE AND ROTOR

- (a) Inspect the pressure plate and rotor surfaces for wear and scoring. Replace if necessary.  
(b) Check the rotor bearings for wear and leakage of grease. Replace if necessary.

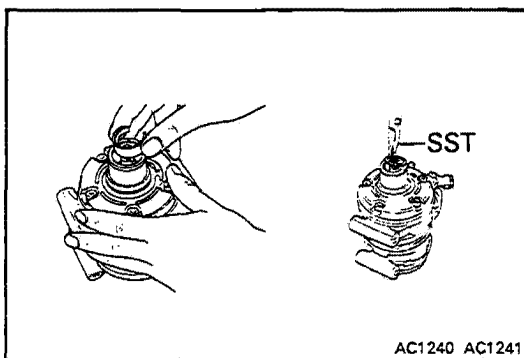
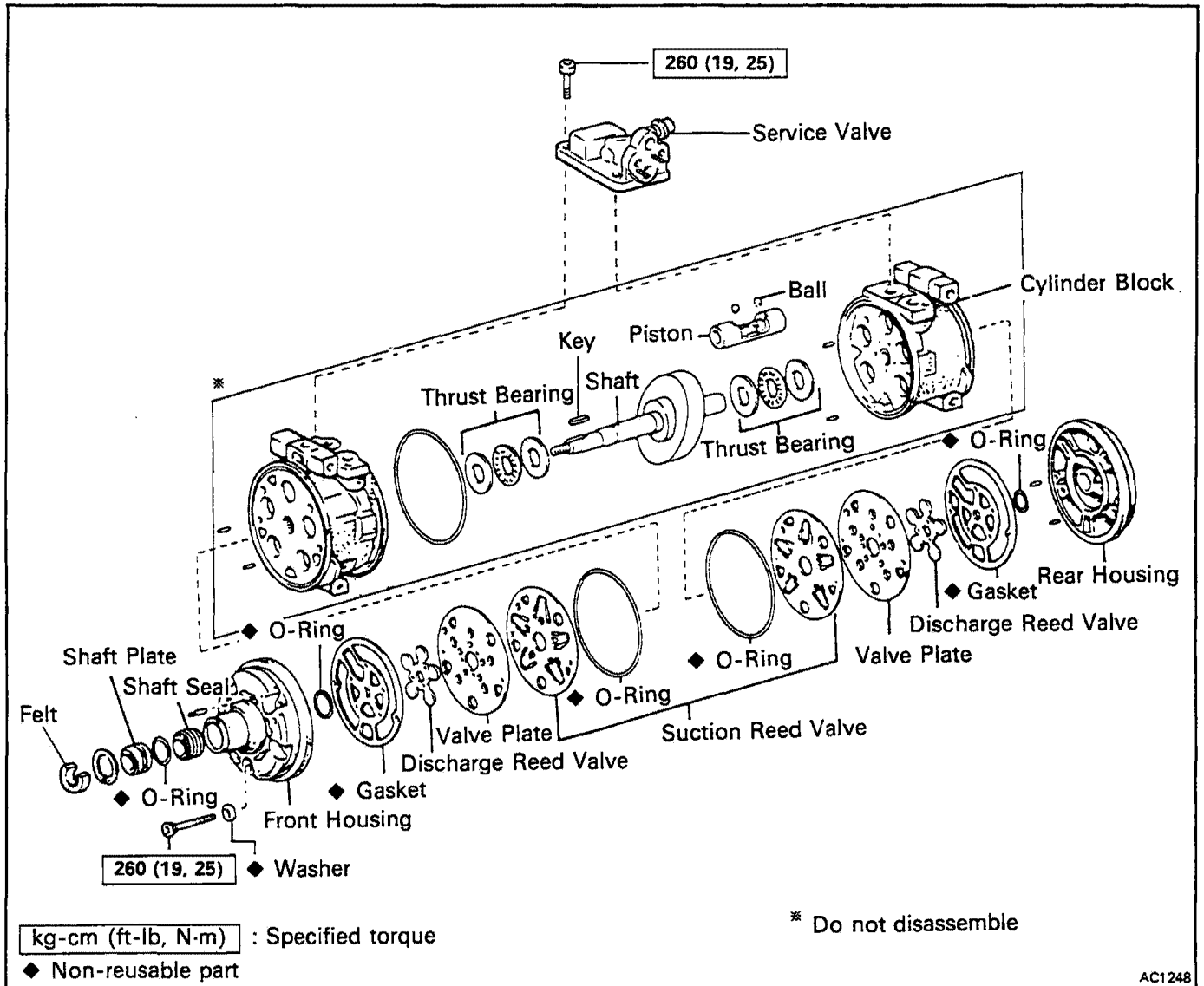

## DISASSEMBLY OF COMPRESSOR

1. REMOVE FELT

2. REMOVE SNAP LING

Using SST, remove the snap ring.  
SST 07114-84020

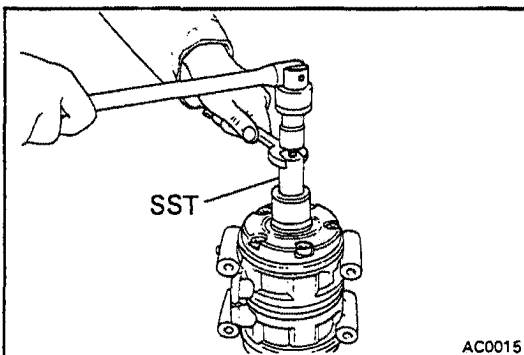

3. REMOVE KEY

Using SST, remove the key from the shaft.  
SST 07112-45021

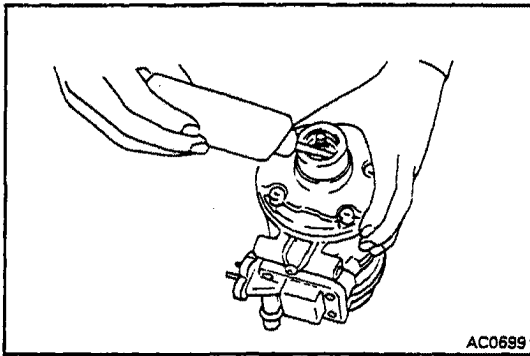

#### 4. APPLY COMPRESSOR OIL TO INNER BORE

Apply compressor oil to the inner bore of the compressor.

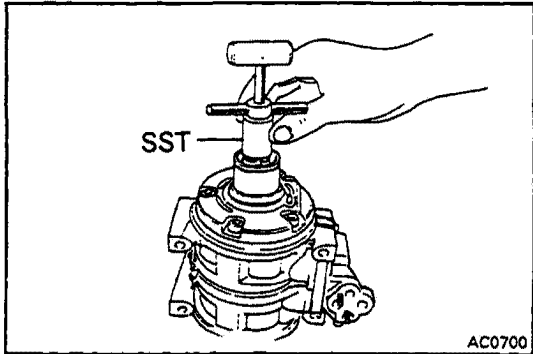

#### 5. REMOVE SHAFT PLATE

(a) Insert SST against the shaft. Then push the holder ring downward.

SST 07112-15010

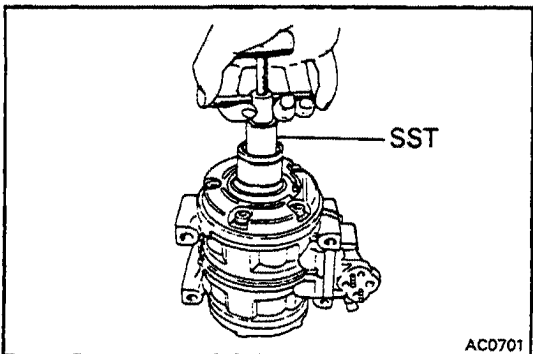

(b) Pull up the remover bar, and remove the shaft plate.

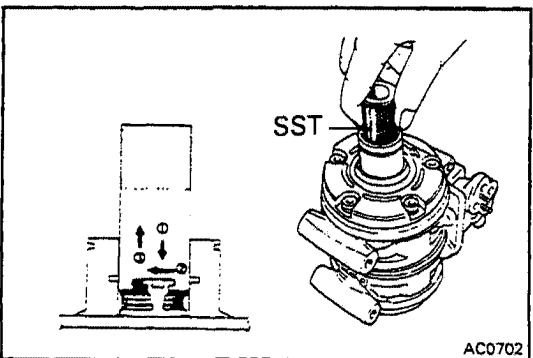

#### 6. REMOVE SHAFT SEAL

Insert SST against the shaft, and turn it to the right while pressing on the remover.

Then remove the shaft seal.

SST 07112-25010

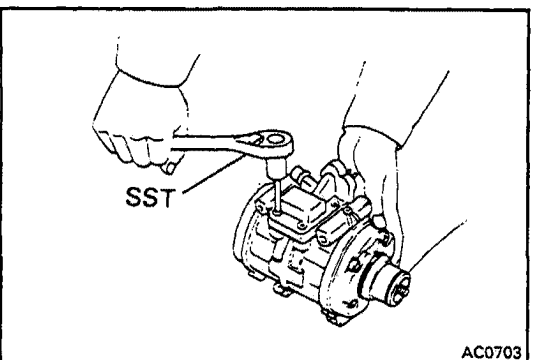

#### 7. REMOVE SERVICE VALVE

(a) Using SST, remove the bolts holding the service valve.

SST 07110-61050

(b) Remove the O-ring from the service valve and discard them.

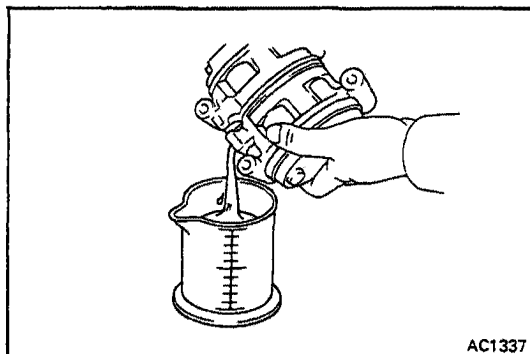

### 8. DRAIN COMPRESSOR OIL INTO MEASURING FLASK

Measure the quantity of drained oil because the same amount should be replaced later.

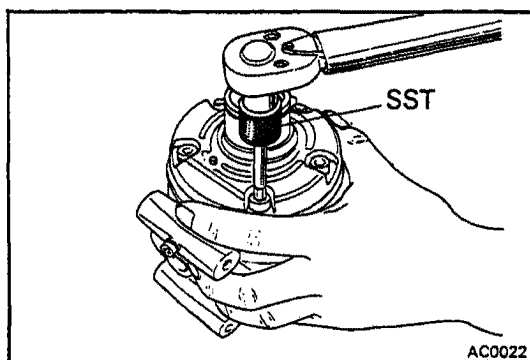

### 9. REMOVE FRONT HOUSING

(a) Using SST, remove the five through bolts.

NOTE: Do not reuse the five washers.

SST 07110-61050

(b) Using a screwdriver, remove the front housing.

**CAUTION:** Be careful not to scratch the sealing surface of the front housing.

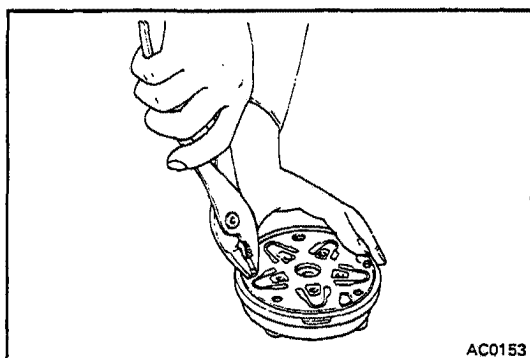
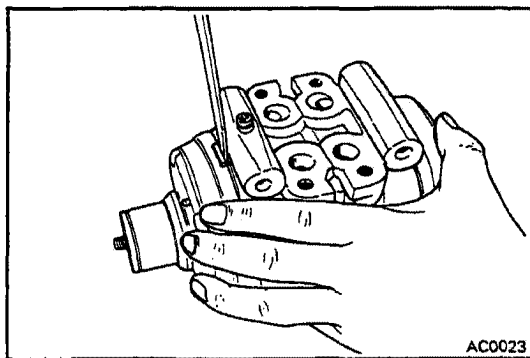

### 10. REMOVE FRONT VALVE PLATE

Remove the two pins from the front housing. Discard the pins.

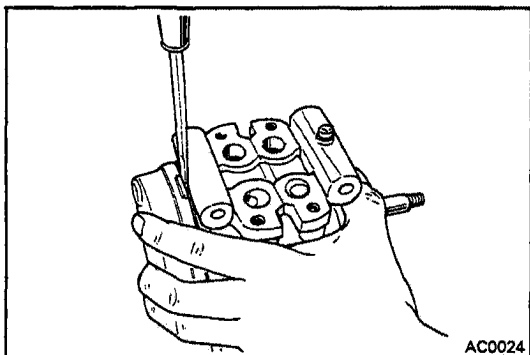

### 11. REMOVE REAR HOUSING

Using a screwdriver, remove the rear housing.

**CAUTION:** Be careful not to scratch the sealing surface of the rear housing.

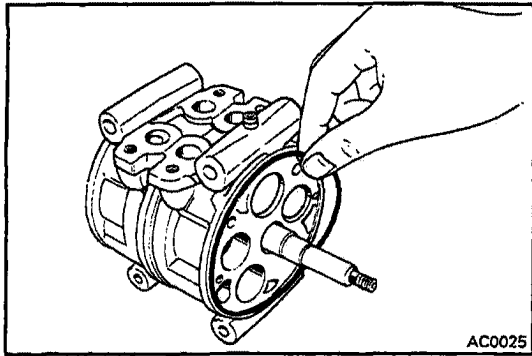

## 12. REMOVE FRONT AND REAR O-RING FROM CYLINDER BLOCK

Discard the O-rings.

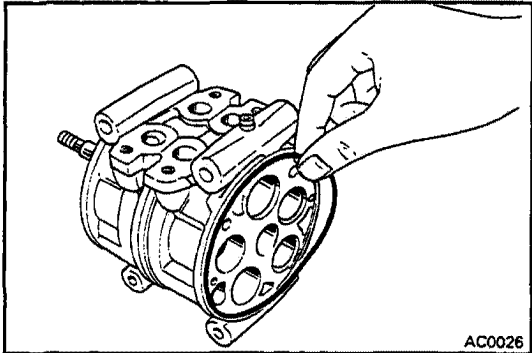

## ASSEMBLY OF COMPRESSOR

### 1. INSTALL REAR VALVE PLATE ON REAR CYLINDER

- (a) Install two pins in the rear cylinder.
- (b) Lubricate a new O-ring with compressor oil. Install the O-ring in the rear cylinder.

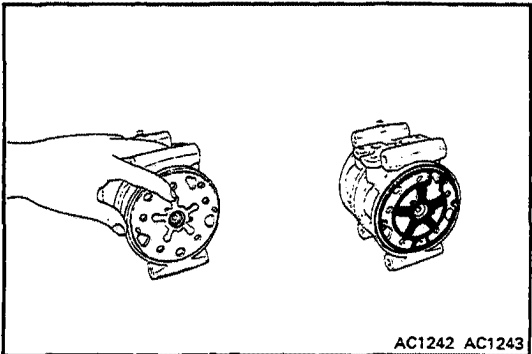

- (c) Install the rear suction valve over the pins on the rear cylinder.

NOTE: The front and rear suction valves are identical.

- (d) Install the rear valve plate together with the discharge valve over the pins on the rear cylinder.

NOTE: The rear valve plate is marked with an "R."

- (e) Lubricate the new gasket with compressor oil. Install the gasket on the valve plate.

### 2. INSTALL REAR HOUSING ON REAR CYLINDER

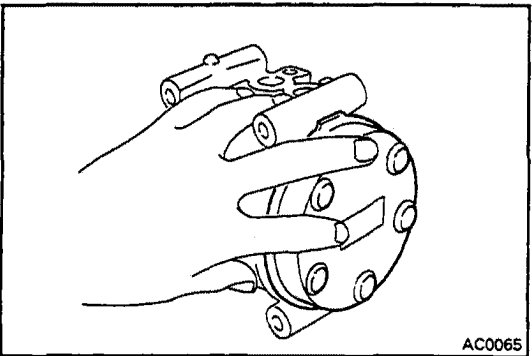

### 3. INSTALL FRONT VALVE PLATE ON FRONT CYLINDER

- (a) Install the two pins in the front cylinder.
- (b) Lubricate a new O-ring with compressor oil. Install the O-ring in the rear housing.
- (c) Install the front suction valve over the pins on the front cylinder.
- (d) Install the front valve plate together with the discharge valve over the pins on the front cylinder.

NOTE: The front valve plate is marked with a "F."

- (e) Lubricate the new gasket with compressor oil. Install the gasket on the valve plate.

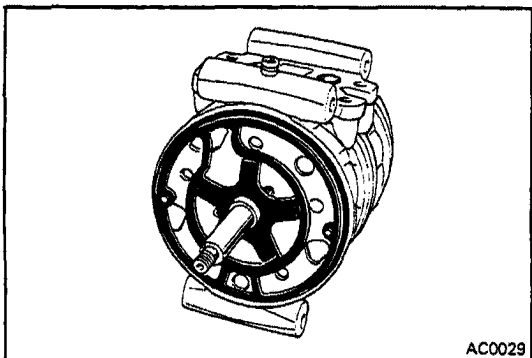

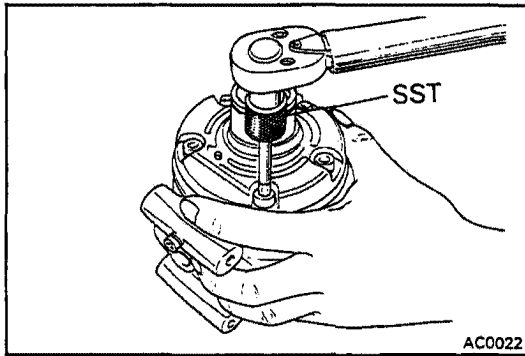

**4. INSTALL FRONT HOUSING ON FRONT CYLINDER AND TIGHTEN FIVE THROUGH BOLTS**

Using SST and torque wrench, gradually tighten the five through bolts in two or three passes.

SST 07110-61050

**Torque: 260 kg-cm (19 ft-lb, 25 N·m)**

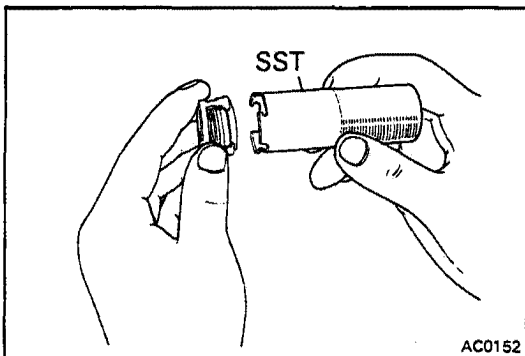

**5. INSTALL SHAFT SEAL**

(a) Fit the shaft seal onto SST.

SST 07112-25010

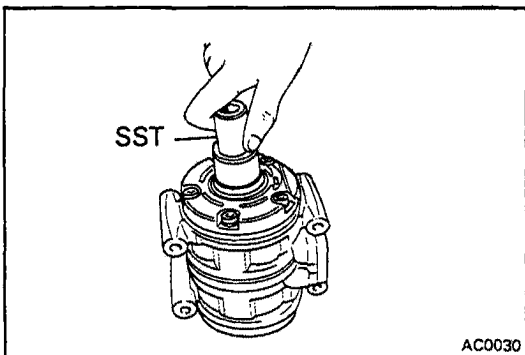

(b) Apply oil to the bore.

Insert SST, and turn it counterclockwise while lightly pressing in.

Then pull up the SST.

SST 07112-25010

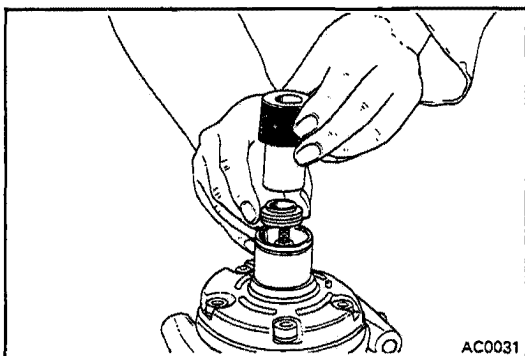

**6. INSTALL SHAFT PLATE**

(a) Put in the shaft plate.

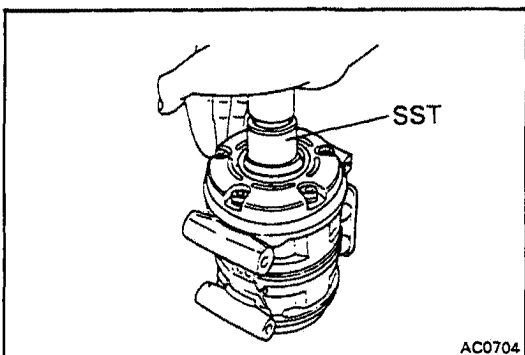

(b) Press in SST.

SST 07114-15010

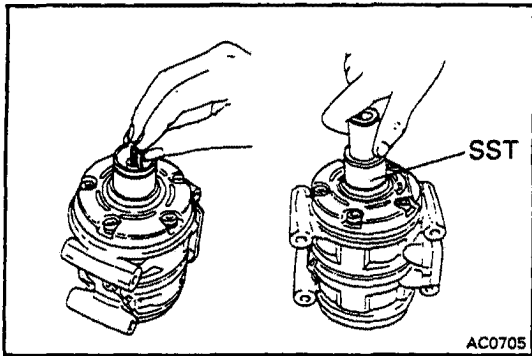
**7. INSTALL KEY IN SHAFT GROOVE**

Using SST and plastic hammer, tap the key lightly.

SST 07114-45010

Place the felt inside the bore.

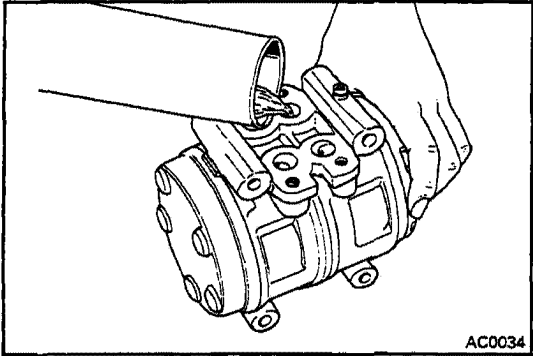
**8. POUR COMPRESSOR OIL INTO COMPRESSOR**

Add the same quantity plus 20cc of oil into the compressor.

Compressor oil: DENSO OIL6  
SUNISO NO. 5GS

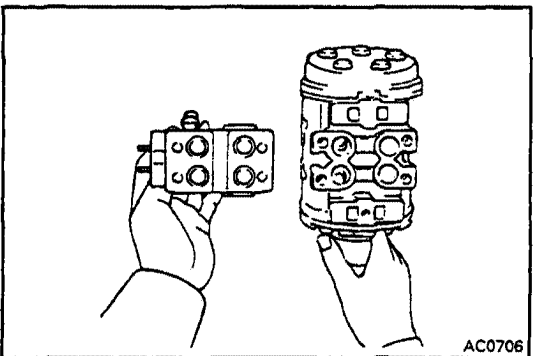
**9. INSTALL SERVICE VALVE**

(a) Lubricate new O-ring with compressor oil. Install the O-rings in the service valve.

(b) Install the service valve on the compressor. Using SST and torque wrench, tighten the bolts.

SST 07110-61050

Torque: 260 kg-cm (19 ft-lb, 25 N·m)

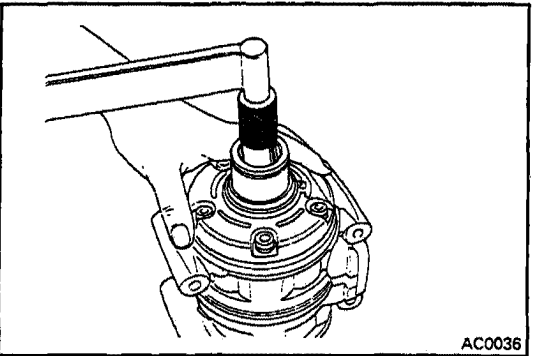
**10. CHECK SHAFT STARTING TORQUE**

Torque: 30 kg-cm (26 in.-lb, 2.9 N·m) or less

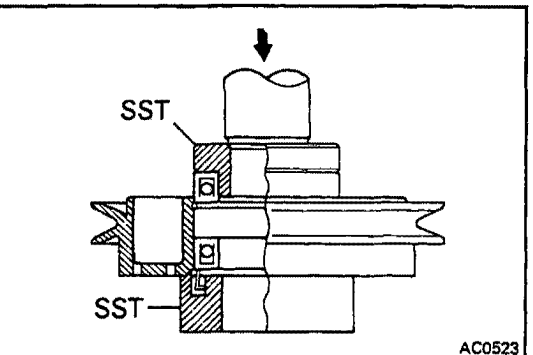
**ASSEMBLY OF MAGNETIC CLUTCH****1. INSTALL TWO BEARINGS IN ROTOR**

(a) Using SST, press a shield ring and two new bearings into the rotor boss until fully seated.

SST 07110-77011

(b) Install the bearing snap ring into the rotor groove.

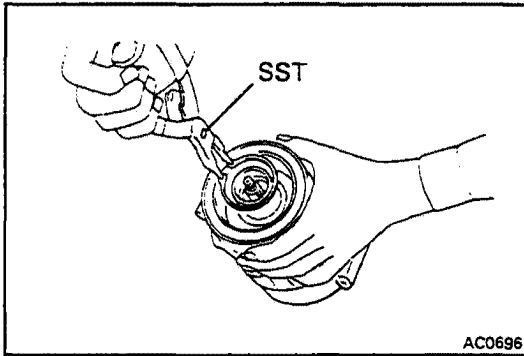

## 2. INSTALL STATOR

- (a) Install the stator on the compressor.
- (b) Using SST, install the new snap ring.  
SST 07114-84020
- (c) Connect the stator lead wires to the compressor housing.

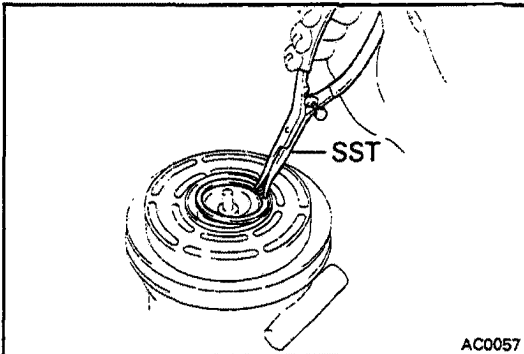

## 3. INSTALL ROTOR

- (a) Install the rotor on the compressor shaft.
- (b) Using SST, install the new snap ring.  
SST 07114-84020

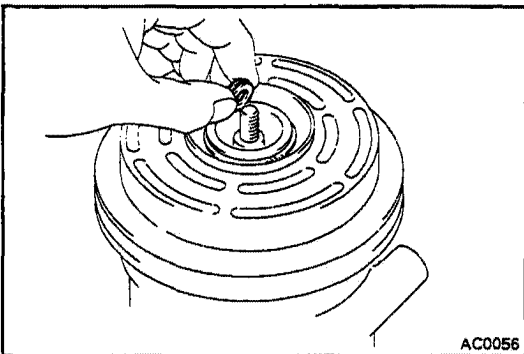

## 4. INSTALL PRESSURE PLATE

- (a) Adjust the clearance between the pressure plate and rotor by putting shims on the compressor shaft.

### Standard clearance:

**0.6 – 1.0 mm (0.024 – 0.039 in.)**

If the clearance is not within tolerance, add or reduce the number of shims to obtain the standard clearance.

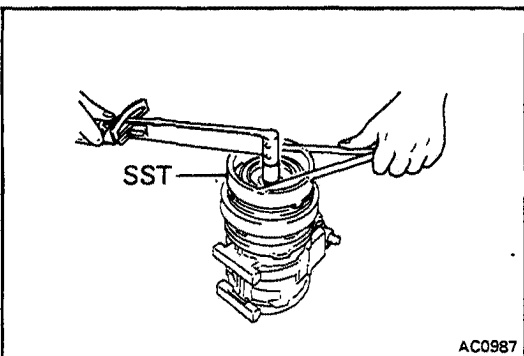

- (b) Using SST and torque wrench, install the shaft nut.  
SST 07112-76040

**Torque: 165 kg-cm (12 ft-lb, 16 N-m)**

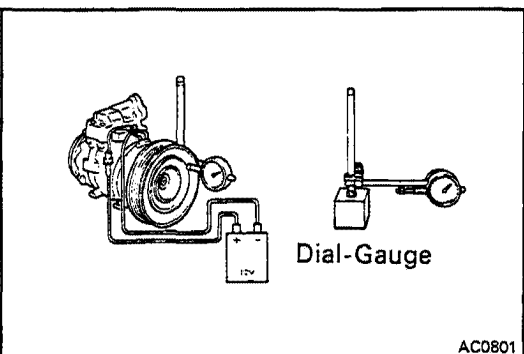

## 5. CHECK CLEARANCE OF MAGNETIC CLUTCH

- (a) Set the dial-gauge to the pressure plate of the magnetic clutch.
- (b) Connect the magnetic clutch lead wire to the positive (+) terminal of the battery.
- (c) Check the clearance between the pressure plate and rotor, when connect the negative (-) terminal of the battery.

### Standard Clearance:

**0.6 – 1.0 mm (0.024 – 0.039 in.)**

If the clearance is not within standard clearance adjust the clearance using shims to obtain the standard clearance.

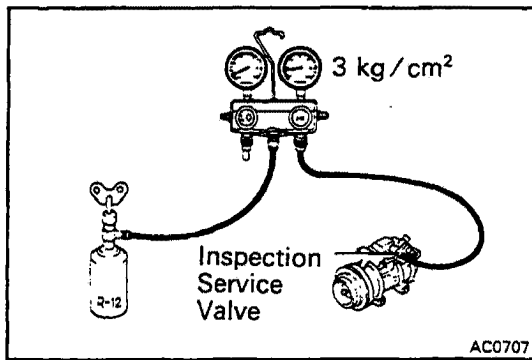

## PERFORMANCE TEST OF COMPRESSOR

### 1. PERFORM GAS LEAKAGE TEST

- (a) Install the inspection service valve on the service valve.

NOTE: Use only a TOYOTA supplied inspection service valve for the perform gas leakage test.

Part No. Suction side 88376-17010  
Discharge side 88376-22030

- (b) Charge the compressor with refrigerant through the charge valve until the pressure is  $3 \text{ kg / cm}^2$  (43 psi, 294 kPa).
- (c) Using gas leak detector, check the compressor for leaks.

If leaks are found, check and replace the compressor.

### 2. EVACUATE COMPRESSOR AND CHARGE WITH REFRIGERANT

Make sure the caps are tight and the compressor is free from the moisture and contamination.

NOTE: When storing a compressor for an extended period, charge the compressor with refrigerant or dry nitrogen gas to prevent corrosion.

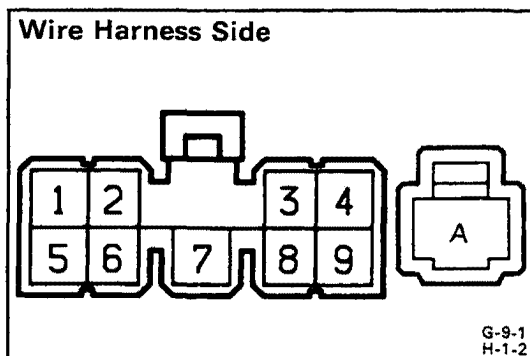

## AIR CONDITIONER AMPLIFIER

### INSPECTION OF AMPLIFIER

#### INSPECT AMPLIFIER CIRCUIT

Disconnect the amplifier and inspect the connector on the wire harness side as shown in the chart below.

Test conditions:

- (1) Ignition switch: ON
- (2) Temperature control lever: MAX COOL
- (3) Blower switch: HI

Check for	Tester connection	Condition	Specified value
Continuity	6 – Ground	—	Continuity
Voltage	2 – 6	Turn A/C switch on.	Battery voltage
		Turn A/C switch off	No voltage
Voltage	3 – 6	Turn A/C switch on.	Battery voltage
		Turn A/C switch off	No voltage
Voltage	A – 6	Turn on IG switch to ST position	Battery voltage
		Turn off IG switch	No voltage
Continuity	7 – 6	—	Continuity
Continuity	8 – 9	—	Continuity
Continuity	9 – Ground	—	Continuity

If circuit is correct, replace the amplifier

- MEMO -

---

# SERVICE SPECIFICATIONS

	Page
MAINTENANCE .....	A-2
ENGINE MECHANICAL .....	A-3
EFI SYSTEM .....	A-7
COOLING SYSTEM .....	A-10
LUBRICATION SYSTEM .....	A-10
IGNITION SYSTEM .....	A-11
STARTING SYSTEM .....	A-11
CHARGING SYSTEM .....	A-11
AUTOMATIC TRANSMISSION .....	A-12
FRONT AXLE AND SUSPENSION .....	A-12
REAR AXLE AND SUSPENSION .....	A-13
LUBRICANT .....	A-14

**MAINTENANCE****Engine**

Drive belt tension w/ Borroughs drive belt tension gauge No. BT-33-73F or Nippondenso BTG-20 (95506-00020)				
Alternator	New belt		145 ± 25 lb	
	Used belt		100 ± 20 lb	
PS pump (Air pump)	New belt		145 ± 25 lb	
	Used belt		100 ± 20 lb	
A/C compressor	New belt		125 ± 25 lb	
	Used belt		80 ± 20 lb	
Engine oil capacity	Drain and refill			
	w/ Oil filter change		7.8 liters	8.2 US qts    7.0 Imp. qts
	w/o Oil filter change		7.0 liters	7.4 US qts    6.2 Imp. qts
Coolant capacity	w/ Front heater		17.5 liters	18.5 US qts    15.4 Imp. qts
	w/ Front and rear heaters		19.5 liters	20.6 US qts    17.2 Imp. qts
Spark plug	Type	ND	W16EXR-U	
		NGK	BPR5EY	
	Gap	STD	0.8 mm	0.031 in.
Firing order			1 – 5 – 3 – 6 – 2 – 4	
Valve clearance (Hot)		Intake	0.20 mm	0.008 in.
		Exhaust	0.35 mm	0.014 in.

**Chassis**

Front and rear brake				
Pad thickness	Limit	4.0 mm	0.158 in.	
Disc thickness	Limit	19.0 mm	0.748 in.	
Disc runout	Limit	0.15 mm	0.0059 in.	
Rear brake				
Lining thickness	Limit	1.5 mm	0.059 in.	
Drum inner diameter	Limit	297.0 mm	11.693 in.	
Front axle and suspension				
Wheel bearing friction preload (starting)		2.8 – 5.7 kg	6.2 – 12.6 lb	27 – 56 N
Steering wheel freeplay		Max. 40 mm (1.57 in.)		
Torque specifications				
Seat mounting bolts		380 kg-cm	27 ft-lb	37 N·m
Leaf spring U-bolt		1,450 kg-cm	105 ft-lb	142 N·m

**ENGINE MECHANICAL****Specifications**

Idle speed			650 rpm		
Intake manifold vacuum		at Idle speed	420 mmHg (16.54 in.Hg, 56.0 kPa) or more		
Compression pressure		at 250 rpm	STD	10.5 kg/cm <sup>2</sup> (149 psi, 1,030 kPa) or more	
			Limit	8.0 kg/cm <sup>2</sup> 114 psi 785 kPa	
		Difference of pressure between each cylinder		0.5 kg/cm <sup>2</sup> (7 psi, 49 kPa) or less	
Cylinder head	Cylinder block surface warpage	Limit		0.15 mm 0.0059 in.	
	Manifold surface warpage	Limit		0.10 mm 0.0039 in.	
	Valve seat Refacing angle	Intake		25°, 45°, 70°	
		Exhaust		45°, 65°	
	Contacting angle			45°	
	Contacting width	Intake		1.1 – 1.7 mm	0.043 – 0.067 in.
	Exhaust		1.4 – 2.0 mm	0.055 – 0.079 in.	
Valve guide bushing	Inside diameter		8.010 – 8.030 mm	0.3154 – 0.3161 in.	
	Outside diameter	STD	14.028 – 14.041 mm	0.5523 – 0.5528 in.	
		O/S 0.05	14.078 – 14.091 mm	0.5543 – 0.5548 in.	
Valve	Overall length	STD	Intake	124.8 mm	4.913 in.
			Exhaust	128.0 mm	5.039 in.
		Limit	Intake	124.3 mm	4.894 in.
			Exhaust	127.5 mm	5.020 in.
	Face angle		IN & EX	44.5°	
	Stem diameter		Intake	7.970 – 7.985 mm	0.3138 – 0.3144 in.
			Exhaust	7.960 – 7.975 mm	0.3134 – 0.3140 in.
	Stem oil clearance	STD	Intake	0.025 – 0.060 mm	0.0010 – 0.0024 in.
			Exhaust	0.035 – 0.070 mm	0.0014 – 0.0028 in.
		Limit	Intake	0.10 mm	0.0039 in.
			Exhaust	0.12 mm	0.0047 in.
	Margin thickness	STD	Intake	1.5 – 2.1 mm	0.059 – 0.083 in.
		Exhaust	1.7 – 2.3 mm	0.067 – 0.091 in.	
Limit		Intake	1.0 mm	0.039 in.	
		Exhaust	1.2 mm	0.047 in.	
Valve spring	Squareness	Limit	1.8 mm	0.071 in.	
	Free length	STD	51.5 mm	2.028 in.	
		Limit	50.0 mm	1.967 in.	
	Installed tension at 43.0 mm (1.693 in.)	STD	32.5 kg	71.6 lb	319 N
		Limit	27 kg	59.5 lb	265 N
Valve rocker arm and shaft	Rocker arm inside diameter	STD	18.494 – 18.515 mm	0.7281 – 0.7289 in.	
	Shaft diameter	STD	18.464 – 18.485 mm	0.7269 – 0.7278 in.	
	Rocker arm oil clearance	STD	0.009 – 0.051 mm	0.0004 – 0.0020 in.	
		Limit	0.08 mm	0.0031 in.	
Push rod	Circle runout	Limit	1.0 mm	0.039 in.	

## Specifications (Cont'd)

Manifold	Warpage	Limit	0.50 mm	0.0197 in.			
Air intake chamber	Warpage		0.2 mm	0.008 in.			
Timing gear	Backlash	STD	0.100 – 0.183 mm	0.0039 – 0.0072 in.			
		Limit	0.25 mm	0.0098 in.			
Camshaft and bearing	Circle runout	Limit	0.30 mm	0.0118 in.			
	Cam lobe height	STD	IN	38.36 – 38.46 mm	1.5102 – 1.5142 in.		
			EX	38.25 – 38.35 mm	1.5059 – 1.5098 in.		
		Limit	IN	38.0 mm	1.496 in.		
			EX	37.9 mm	1.492 in.		
	Journal diameter	STD	No. 1	47.955 – 47.975 mm	1.8880 – 1.8888 in.		
			No. 2	46.455 – 46.475 mm	1.8289 – 1.8297 in.		
			No. 3	44.955 – 44.975 mm	1.7699 – 1.7707 in.		
			No. 4	43.455 – 43.475 mm	1.7108 – 1.7116 in.		
			U/S 0.25	No. 1	47.715 – 47.725 mm	1.8785 – 1.8789 in.	
				No. 2	46.215 – 46.225 mm	1.8195 – 1.8199 in.	
				No. 3	44.715 – 44.725 mm	1.7604 – 1.7608 in.	
				No. 4	43.215 – 43.225 mm	1.7014 – 1.7018 in.	
		U/S 0.50	No. 1	47.465 – 47.475 mm	1.8687 – 1.8691 in.		
			No. 2	45.965 – 45.975 mm	1.8096 – 1.8888 in.		
			No. 3	44.465 – 44.475 mm	1.7506 – 1.7510 in.		
			No. 4	42.965 – 42.975 mm	1.6915 – 1.6919 in.		
			Bearing inside diameter	STD	No. 1	48.000 – 48.030 mm	1.8898 – 1.8909 in.
					No. 2	46.500 – 46.530 mm	1.8307 – 1.8319 in.
					No. 3	45.000 – 45.030 mm	1.7717 – 1.7728 in.
					No. 4	43.500 – 43.530 mm	1.7126 – 1.7138 in.
	U/S 0.25	No. 1		47.750 – 47.825 mm	1.8799 – 1.8829 in.		
		No. 2		46.250 – 46.325 mm	1.8209 – 1.8238 in.		
		No. 3		44.750 – 44.820 mm	1.7618 – 1.7646 in.		
		No. 4		43.250 – 43.320 mm	1.7028 – 1.7055 in.		
	U/S 0.50	No. 1	47.500 – 47.575 mm	1.8701 – 1.8730 in.			
		No. 2	46.000 – 46.075 mm	1.8110 – 1.8140 in.			
		No. 3	44.500 – 44.570 mm	1.7520 – 1.7547 in.			
		No. 4	43.000 – 43.070 mm	1.6929 – 1.6957 in.			
	Journal oil clearance	STD	STD	0.025 – 0.075 mm	0.0010 – 0.0030 in.		
			U/S 0.25 and 0.50				
		Limit	No. 1 and No. 2	0.025 – 0.110 mm	0.0010 – 0.0043 in.		
No. 3 and No. 4			0.025 – 0.105 mm	0.0010 – 0.0041 in.			
STD			0.10 mm	0.0039 in.			
U/S 0.25 and 0.50			0.15 mm	0.0059 in.			
Thrust clearance	STD	0.200 – 0.290 mm	0.0079 – 0.0114 in.				
	Limit	0.33 mm	0.0130 in.				
Valve lifter	Lifter diameter	STD	21.387 – 21.404 mm	0.8420 – 0.8427 in.			
		O/S 0.05	21.437 – 21.454 mm	0.8440 – 0.8446 in.			
	Cylinder block lifter bore diameter		21.417 – 21.443 mm	0.8432 – 0.8442 in.			

### Specifications (Cont'd)

Valve lifter (cont'd)	Lifter oil clearance	STD Limit	0.013 – 0.056 mm 0.10 mm	0.0005 – 0.0022 in. 0.0039 in.	
Cylinder block	Warpage	Limit	0.15 mm	0.0059 in.	
	Cylinder bore diameter	STD	94.000 – 94.030 mm	3.7008 – 3.7020 in.	
		Limit	94.23 mm	3.7098 in.	
		O/S 0.50	94.73 mm	3.7295 in.	
		O/S 1.00	95.23 mm	3.7492 in.	
O/S 1.50	95.73 mm	3.7689 in.			
Piston and piston ring	Piston diameter	STD	93.963 – 93.993 mm	3.6993 – 3.7005 in.	
		O/S 0.50	94.463 – 94.493 mm	3.7190 – 3.7202 in.	
		O/S 1.00	94.963 – 94.993 mm	3.7387 – 3.7399 in.	
		O/S 1.50	95.463 – 95.493 mm	3.7584 – 3.7596 in.	
	Piston oil clearance		0.027 – 0.047 mm	0.0011 – 0.0019 in.	
	Piston ring groove clearance	No. 1	0.030 – 0.070 mm	0.0012 – 0.0028 in.	
		No. 2	0.050 – 0.090 mm	0.0020 – 0.0035 in.	
	Piston ring end gap	STD	No. 1 No. 2	0.200 – 0.420 mm 0.500 – 0.720 mm	0.0079 – 0.0165 in.. 0.0197 – 0.0283 in.
			Oil	0.200 – 0.820 mm	0.0079 – 0.0323 in.
		Limit	No. 1	1.02 mm	0.0402 in.
			No. 2	1.32 mm	0.0520 in.
			Oil	1.42 mm	0.0559 in.
	Connecting rod and piston pin	Thrust clearance	STD	0.160 – 0.300 mm	0.0063 – 0.0118 in.
Limit			0.40 mm	0.0156 in.	
Connecting rod bearing center wall thickness		STD	Mark A	1.484 – 1.488 mm	0.0584 – 0.0586 in.
			Mark B	1.488 – 1.492 mm	0.0586 – 0.0587 in.
			Mark C	1.492 – 1.496 mm	0.0587 – 0.0589 in.
Connecting rod oil clearance		STD	STD	0.020 – 0.050 mm	0.0008 – 0.0020 in.
		Limit	U/S 0.25 and 0.50	0.019 – 0.063 mm	0.0007 – 0.0025 in.
Bend per 100 mm (3.94 in.)		Limit	0.10 mm	0.0039 in.	
Twist per 100 mm (3.94 in.)		Limit	0.05 mm	0.0020 in.	
Bushing inside diameter				0.15 mm	0.0059 in.
Piston pin diameter				22.012 – 22.027 mm	0.8666 – 0.8672 in.
Piston pin to bushing oil clearance				22.004 – 22.019 mm	0.8663 – 0.8669 in.
	STD		0.005 – 0.011 mm	0.0002 – 0.0004 in.	
Limit		0.03 mm	0.0012 in.		
Crankshaft and bearing	Thrust clearance	STD	0.015 – 0.204 mm	0.0006 – 0.0080 in.	
		Limit	0.30 mm	0.0118 in.	
	Thrust washer thickness	STD		2.430 – 2.480 mm	0.0957 – 0.0976 in.
		O/S 0.125		2.493 – 2.543 mm	0.0981 – 0.1001 in.
		O/S 0.250		2.555 – 2.605 mm	0.1006 – 0.1026 in.
	Main journal oil clearance	STD	STD	0.020 – 0.044 mm	0.0008 – 0.0017 in.
Limit		U/S 0.25 and 0.50	0.021 – 0.067 mm	0.0008 – 0.0026 in.	
			0.10 mm	0.0039 in.	

## Specifications (Cont'd)

Crankshaft and bearing (cont'd)	Main journal diameter	STD	No. 1	66.972 – 66.996 mm	2.6367 – 2.6376 in.	
			No. 2	68.472 – 68.496 mm	2.6957 – 2.6967 in.	
			No. 3	69.972 – 69.996 mm	2.7548 – 2.7557 in.	
			No. 4	71.472 – 71.496 mm	2.8139 – 2.8148 in.	
		U/S 0.25	No. 1	66.745 – 66.755 mm	2.6278 – 2.6281 in.	
			No. 2	68.245 – 68.255 mm	2.6868 – 2.6872 in.	
			No. 3	69.745 – 69.755 mm	2.7459 – 2.7463 in.	
			No. 4	71.245 – 71.255 mm	2.8049 – 2.8053 in.	
		U/S 0.50	No. 1	66.495 – 66.505 mm	2.6179 – 2.6183 in.	
			No. 2	67.995 – 68.005 mm	2.6770 – 2.6774 in.	
			No. 3	69.495 – 69.505 mm	2.7360 – 2.7364 in.	
			No. 4	70.995 – 71.005 mm	2.7951 – 2.7955 in.	
		Main bearing center wall thickness	STD	Mark T1	2.493 – 2.497 mm	0.0981 – 0.0983 in.
				Mark T2	2.497 – 2.501 mm	0.0983 – 0.0985 in.
				Mark T3	2.501 – 2.505 mm	0.0985 – 0.0986 in.
				Mark T4	2.505 – 2.509 mm	0.0986 – 0.0988 in.
	Mark T5			2.509 – 2.513 mm	0.0988 – 0.0989 in.	
	Crank pin diameter	STD	STD	52.988 – 53.000 mm	2.0861 – 2.0866 in.	
			U/S 0.25	52.701 – 52.711 mm	2.0748 – 2.0752 in.	
			U/S 0.50	52.451 – 52.461 mm	2.0650 – 2.0654 in.	
Circle runout		Limit	0.12 mm	0.0048 in.		
Taper and out-of-round						
Main journal and crank pin		Limit	0.02 mm	0.0008 in.		

## Torque Specifications

Part tightened	kg-cm	ft-lb	N-m
Cylinder head x Cylinder block	1,250	90	123
Valve rocker support x Cylinder head			
12 mm bolt head	240	17	24
14 mm bolt head and nut	340	25	33
Manifold x Cylinder head			
14 mm bolt head	510	37	50
17 mm bolt head	700	51	69
Nut	570	41	56
Cylinder head cover x Cylinder head	90	78 in.-lb	8.8
Intake manifold x Intake manifold stay	300	22	29
Cylinder block x Intake manifold stay	300	22	29
Air injection manifold x Cylinder head	210	15	21
Exhaust manifold x Exhaust pipe	630	46	62
Water outlet housing x Cylinder head	250	18	25
Camshaft thrust washer x Cylinder block	120	9	12
Timing gear cover x Front end plate or cylinder block			
10 mm bolt head	50	43 in.-lb	4.9
14 mm bolt head	250	18	25
Crankshaft pulley x Crankshaft	3,500	253	343



Specifications (Cont'd)

Air flow meter (cont'd)	Resistance E2 – THA (cont'd)	at -20°C (-4°F) at 0°C (32°F) at 20°C (68°F) at 40°C (104°F) at 60°C (140°F)	10 – 20 kΩ 4 – 7 kΩ 2 – 3 kΩ 0.9 – 1.3 kΩ 0.4 – 0.7 kΩ	
Water temp. sensor	Resistance	at -20°C (-4°F) at 0°C (32°F) at 20°C (68°F) at 40°C (104°F) at 60°C (140°F) at 80°C (176°F)	10 – 20 kΩ 4 – 7 kΩ 2 – 3 kΩ 0.9 – 1.3 kΩ 0.4 – 0.7 kΩ 0.2 – 0.4 kΩ	
Oxygen sensor	Heater resistance		5.1 – 6.3 Ω	
EGR gas temp. sensor (calif. only)	Resistance	at 50°C (112°F) at 100°C (212°F) at 150°C (302°F)	69.40 – 88.50 kΩ 11.89 – 14.37 kΩ 2.79 – 3.59 kΩ	
ECU	NOTE: <ul style="list-style-type: none"> <li>• Perform all voltage and resistance measurements with the computer connected.</li> <li>• Verify that the battery voltage is 11 V or above with the ignition switch is ON.</li> </ul>			
	Voltage			
	Terminals	Condition	STD voltage (V)	
	BATT – E1	—	10 – 14	
	IG S/W – E1	Ignition S/W ON	10 – 14	
	M-REL – E1	Ignition S/W ON	10 – 14	
	+ B (+ B1) – E1	Ignition S/W ON	10 – 14	
	IDL – E2	Ignition S/W ON	Throttle valve open	4 – 6
	VC – E2		—	4 – 6
	VTA – E2		Throttle valve fully closed	0.1 – 1.0
			Throttle valve fully open	4 – 5
	VC – E22	Ignition S/W ON	—	4 – 6
	VS – E22		Measuring plate fully closed	4 – 5
			Measuring plate fully open	0.02 – 0.08
			Idling	2 – 4
		3,000 rpm	0.3 – 1.0	
	THA – E2	Ignition S/W ON	Intake air temperature 20°C (68°F)	1 – 3
	THW – E2	Ignition S/W ON	Coolant temperature 80°C (176°F)	0.1 – 1.0
	No. 10 – E01 No. 20 – E02	Ignition S/W ON		9 – 14
	STA – E1	Cranking		6 – 14
	ISC1 ? – E1 ISC4	Ignition S/W ON		9 – 14
	IGT – E1	Idling		0.7 – 1.0
	W – E1	No trouble ("CHECK" engine warning light off) and engine running		8 – 14
A/C – E1	Air conditioning ON		10 – 14	

## Specifications (Cont'd)

ECU (cont'd)	Terminals	Condition		STD voltage (V)
T – E1	Ignition S/W ON	Check connector TE1 – E1 not short	4 – 6	
		Check connector TE1 – E short	0	
NSW – E1	Ignition S/W ON	Shift position P or N range	0	
		Ex. P or N range	10 – 14	
4WD – E1	Ignition S/W ON	4WD S/W ON	10 – 14	
		4WD S/W OFF	0	
STP – E1	Ignition S/W ON	Stop light S/W ON	10 – 14	
		Stop light S/W OFF	0	
Resistance				
	Terminals	Condition	Resistance (Ω)	
IDL – E2		Throttle valve fully open	Infinity	
		Throttle valve fully closed	Less than 2,300	
VTA – E2		Throttle valve fully open	3,500 – 10,300	
		Throttle valve fully closed	300 – 6,300	
VC – E2		—	4,250 – 8,250	
VC – E22		—	200 – 400	
VS – E2		Measuring plate fully closed	20 – 600	
		Measuring plate fully open	20 – 1,200	
THA – E2		Intake air temperature 20°C (68°F)	2,000 – 3,000	
THW – E2		Coolant temperature 80°C (176°F)	200 – 400	
GI – G⊖		—	140 – 180	
NE – G⊖		—	140 – 180	
ISC1, ISC2 ISC3, ISC4	– +B	—	10 – 30	
Fuel cut rpm	Fuel cut rpm	1,300 rpm		
	Fuel return rpm	1,000 rpm		

## Torque Specifications

Part tightened	kg-cm	ft-lb	N-m
Cold start injector pipe x Cold start injector	180	13	18
Cold start injector pipe x Delivery pipe	180	13	18
Cold start injector clamp bolt	120	9	12
Fuel pump bracket x Fuel tank	35	30 in.-lb	3.4
Pressure regulator x Delivery pipe	50	43 in.-lb	4.9
Fuel return pipe x Pressure regulator	180	13	18
Delivery pipe x Intake manifold	120	9	12
Pulsation damper x Delivery pipe	300	22	29
Air intake chamber x Intake manifold	250	18	25
Intake chamber stay mount bolt	120	9	12
EGR pipe union nut	800	58	78
Throttle body x Air intake chamber	120	9	12
ISC valve x Air intake chamber	120	9	12

**COOLING SYSTEM****Specifications**

Engine coolant capacity		See page A-2
Thermostat	Valve opening temperature	86 – 90°C      187 – 194°F
	Valve lift at 100°C (212°F)	10 mm (0.39 in.) or more
Radiator	Relief valve opening pressure    STD	0.75 – 1.05 kg/cm <sup>2</sup> (10.7 – 14.9 psi, 74 – 103 kPa)
	Limit	0.6 kg/cm <sup>2</sup> 8.5 psi      59 kPa

**Torque Specifications**

Part tightened	kg-cm	ft-lb	N-m
Drain plug	450	33	44
Water pump x Cylinder block	380	27	37
Water outlet x Water outlet housing	185	13	18

**LUBRICATION SYSTEM****Specifications**

Engine oil capacity		See page A-2	
Oil pressure	at Idle	0.3 kg/cm <sup>2</sup> (4.3 psi, 29 kPa) or more	
	at 4,000 rpm	2.5 – 5.0 kg/cm <sup>2</sup> (36 – 71 psi, 245 – 490 kPa)	
Oil pump	Body clearance	STD	0.095 – 0.175 mm    0.0037 – 0.0069 in.
		Limit	0.20 mm              0.0079 in.
	Gear side clearance	STD	0.030 – 0.090 mm    0.0012 – 0.0035 in.
		Limit	0.15 mm              0.0059 in.
	Gear backlash	STD	0.500 – 0.600 mm    0.0197 – 0.0236 in.
		Limit	0.95 mm              0.0374 in.

**Torque Specifications**

Part tightened	kg-cm	ft-lb	N-m
Engine oil drain plug	400	29	39
Oil pump strainer x Oil pump body	100	7	10
Relief valve plug x Oil pump strainer	450	33	44
Oil pump x Cylinder block	180	13	18
Oil outlet pipe	450	33	44
Oil pan x Cylinder block	80	69 in.-lb	7.8
Oil filter bracket x Cylinder block	185	13	18
Relief valve x Oil filter bracket	250	18	25
Oil cooler	650	47	64

## IGNITION SYSTEM

Ignition timing		7° BTDC @ idle (Check connector TE1 and E1 short circuit)	
Firing order		1 – 5 – 3 – 6 – 2 – 4	
High-tension cord	Resistance	Limit	25 k $\Omega$ per cord
Spark plug	Type	ND NGK	W16EXR-U BPR5EY
	Correct electrode gap		0.8 mm                      0.031 in.
Ignition coil	Primary coil resistance at cold		0.52 – 0.64 $\Omega$
	Secondary coil resistance at cold		11.5 – 15.5 k $\Omega$
Distributor	Air gap                      G and NE pickups		0.2 mm (0.008 in.) or more
	Pickup coil resistance G and NE pickups		140 – 180 $\Omega$

## STARTING SYSTEM

Starter	Rated voltage and output power		12 V 1.0 kW		
	No-load characteristic		Ampere	90 A or less at 11.5 V	
			rpm	3,000 rpm or more	
Commutator	Outer diameter	STD	30 mm	1.18 in.	
		Limit	29 mm	1.14 in.	
	Under cut depth	STD	0.6 mm	0.024 in.	
		Limit	0.2 mm	0.008 in.	
Brush	Circle runout	Limit	0.05 mm	0.0020 in.	
		Length	STD	13.5 mm	0.531 in.
		Limit	8.5 mm	0.335 in.	
	Spring installed load		1.79 – 2.41 kg	3.9 – 5.3 lb	18 – 24 N

## CHARGING SYSTEM

Drive belt tension		See page A-2			
Battery specific gravity		when fully charged at 20°C (68°F)			
		1.25 – 1.27			
Alternator	Rated output		12 V 80A		
	Rotor coil resistance		2.8 – 3.0 $\Omega$		
	Slip ring diameter	STD	32.3 – 32.5 mm	1.272 – 1.280 in.	
		Limit	32.1 mm	1.264 in.	
	Brush exposed length	STD	20.0 mm	0.789 in.	
Limit		5.5 mm	0.217 in.		
Alternator regulator	Regulating voltage	at 25°C (77°F)	13.8 – 14.4 V		

**AUTOMATIC TRANSMISSION (A440F)****Specifications**

Engine stall revolution		1,950 ± 150 rpm									
Governor pressure											
Output shaft rpm											
1,000	(approx. 32 km/h 20 mph)	0.8 – 1.2 kg/cm <sup>2</sup>		11 – 17 psi		78 – 118 kPa					
1,800	(approx. 57 km/h 35 mph)	1.9 – 2.3 kg/cm <sup>2</sup>		27 – 33 psi		186 – 226 kPa					
3,500	(approx. 111 km/h 69 mph)	5.7 – 6.3 kg/cm <sup>2</sup>		81 – 90 psi		559– 618 kPa					
Shift points km/h (mph)	Tire size	D range (throttle valve fully open)						(fully closed)		2 range	L range
		1→2	2→3	3→O/D	O/D→3	3→2	2→1	Lock-up ON	Lock-up OFF	3→2	2→1
	P225/75 R15	34-48 (21-30)	74-88 (46-55)	109-123 (68-76)	102-116 (63-72)	64-78 (40-48)	29-43 (18-28)	79-92 (49-57)	75-88 (47-55)	81-95 (50-59)	36-50 (22-31)

**FRONT AXLE AND SUSPENSION****Specifications**

Cold tire inflation pressure kg/cm <sup>2</sup> (psi, kPa)	Model		Tire size		Front		Rear		
	FJ62LG FJ62LV		P225/75 R15 EXTRA LOAD		1.8 (26, 180)		2.4 (35, 240)		
Front wheel alignment	Camber				1° ± 45'				
	King pin inclination				9°30' ± 45'				
	Caster	FJ62LG, FJ62LV				0°50' ± 1°			
	Toe-in		FJ62LG, FJ62LV		Inspection STD		Adjustment STD		
					1 ± 2 mm (0.04 ± 0.08 in.)		1 ± 1 mm (0.04 ± 0.04 in.)		
	Wheel angle	Max.	Inside wheel	32°00' <sup>+0°</sup> <sub>-3°</sub>					
			Outside wheel	30°00'					
	at 20° (Outside wheel)	Inside wheel	21°00'						
Side slip				Less than 3.0 mm/m (0.118 in./3.3 ft)					
Disc wheel lateral runout		Limit		1.2 mm		0.047 in.			
Wheel bearing preload (rotating load at hub bolt)		Frictional force of oil seal plus		2.8 – 5.7 kg		6.1 – 12.6 lb			
						27 – 56 N			

## Torque Specifications

Part tightened	kg-cm	ft-lb	N-m
Tie rod clamp bolt	375	27	37
Free wheeling hub body (Flange) x Axle hub	315	23	31
Steering knuckle stopper bolt lock nut	450	33	44
Free wheel hub body x Free wheel hub cover	100	7	10
Steering knuckle arm x Housing	975	71	96
Bearing cap x Housing	975	71	96
Knuckle spindle x Housing	475	34	47
Front axle hub bearing lock nut	900	65	88
Disc brake caliper x Steering knuckle	900	65	88
Disc brake caliper x Brake tube	155	11	15
Spring U-bolt x Axle housing	1,450	105	142
Rear spring bracket x Hanger pin	925	67	91
Frame x Hanger pin	130	9	13
Front spring shackle x Leaf spring	925	67	91
Front shock absorber x Axle housing	650	47	64
Front shock absorber x Frame	260	19	25
Knuckle arm x Tie rod	925	67	91
Front stabilizer bar bracket x Axle housing	130	9	13
Front stabilizer x Frame	180	13	18
Wheel nut	1,600	116	157

## REAR AXLE AND SUSPENSION

### Torque Specifications

Rear axle shaft (Semi-floating type)	Part tightened	kg-cm	ft-lb	N-m
	Differential rear cover x Axle housing	130	9	13
Rear suspension	Spring U-bolt x Axle housing	1,250	90	123
	Front spring bracket x Hanger pin	925	67	91
	Frame x Hanger pin	130	9	13
	Rear spring shackle x Leaf spring	925	67	91
	Rear shock absorber x Axle housing	375	27	37
	Rear shock absorber x Body	650	47	64
	Rear stabilizer bar bracket x Axle housing	130	9	13
	Rear stabilizer bar x Link	260	19	25
	Link x Frame	260	19	25
	Wheel nut	1,600	116	157

**LUBRICANT**

Item	Capacity			Classification
	Liters	US qts	Imp. qts	
Engine oil				API grade SF or SF/CC, multigrade viscosity oil
Dry fill	8.0	8.5	7.0	
Drain and refill				
w/ Oil filter change	7.8	8.2	6.9	
w/o Oil filter change	7.0	7.4	6.2	

---









# STANDARD BOLT TORQUE SPECIFICATIONS

Page

STANDARD BOLT TORQUE SPECIFICATIONS ..... B-2

# STANDARD BOLT TORQUE SPECIFICATIONS

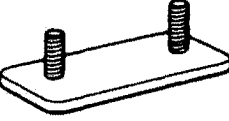
## HOW TO DETERMINE BOLT STRENGTH

	Mark	Class		Mark	Class
Hexagon head bolt	 Bolt head No. 4- 5- 6- 7-	4T 5T 6T 7T	Stud bolt	 No mark	4T
	 No mark	4T			
Hexagon flange bolt w/washer hexagon bolt	 No mark	4T	 Grooved	6T	
Hexagon head bolt	 Two protruding lines	5T			
Hexagon flange bolt w/washer hexagon bolt	 Two protruding lines	6T		4T	
Hexagon head bolt	 Three protruding lines	7T			

## SPECIFIED TORQUE FOR STANDARD BOLTS

Class	Diameter mm	Pitch mm	Specified torque					
			Hexagon head bolt			Hexagon flange bolt		
			kg-cm	ft-lb	N·m	kg-cm	ft-lb	N·m
4T	6	1	55	48 in.-lb	5.4	60	52 in.-lb	5.9
	8	1.25	130	9	13	145	10	14
	10	1.25	260	19	25	290	21	28
	12	1.25	480	35	47	540	39	53
	14	1.5	760	55	75	850	61	83
	16	1.5	1,150	83	113	-	-	-
5T	6	1	65	56 in.-lb	6.4	-	-	-
	8	1.25	160	12	16	-	-	-
	10	1.25	330	24	32	-	-	-
	12	1.25	600	43	59	-	-	-
	14	1.5	930	67	91	-	-	-
	16	1.5	1,400	101	137	-	-	-
6T	6	1	80	69 in.-lb	7.8	90	78 in.-lb	8.8
	8	1.25	195	14	19	215	16	21
	10	1.25	400	29	39	440	32	43
	12	1.25	730	53	72	810	59	79
	14	1.5	-	-	-	1,250	90	123
7T	6	1	110	8	11	120	9	12
	8	1.25	260	19	25	290	21	28
	10	1.25	530	38	52	590	43	58
	12	1.25	970	70	95	1,050	76	103
	14	1.5	1,500	108	147	1,700	123	167
	16	1.5	2,300	166	226	-	-	-

- MEMO -

---

---

# SST AND SSM

	<b>Page</b>
<b>SST (SPECIAL SERVICE TOOLS) .....</b>	<b>C-2</b>
<b>SSM (SPECIAL SERVICE MATERIALS) .....</b>	<b>C-6</b>







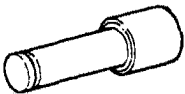
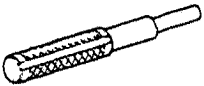

# SST (SPECIAL SERVICE TOOLS)

NOTE: Classification



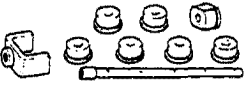

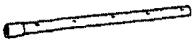





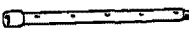

A = SST required for vehicle inspections and minor repairs and multipurpose SST.

B = SST required for major repairs involving disassembly of components.





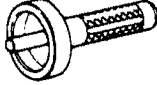



C = SST required for rather special, less frequent work not of classifiable as either A or B.

Section	Classification	Part Name	Part No.	Illustration	EM	EC	FI	CO	LU	ST	CH	FA	RA
					09201-31010	(Valve Stem Oil Seal Replacer)	B	●					
					09201-60011	(Valve Guide Bushing Remover & Replacer)	A	●					
					09202-43013	(Valve Spring Compressor)	A	●					
					09213-58011	(Crankshaft Pulley Holding Tool)	A	●					
					09213-60017	(Crankshaft Pulley & Gear Pulley Set)	A	●					
					09214-60010	(Crankshaft Pulley & Gear Replacer)	B	●					
					09215-00012	(Camshaft Bearing Remover & Replacer Set)	C	●					
					(09215-00020)	(Gate "B")		●					
					(09215-00030)	(Shaft "B")		●					
					(09215-00410)	(Camshaft Bearing Remover & Replacer)		●					

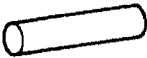
# SST (SPECIAL SERVICE TOOLS) (Cont'd)



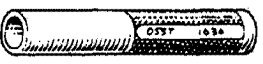

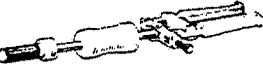
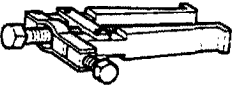
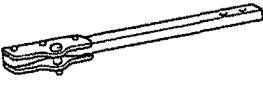

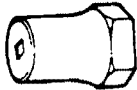
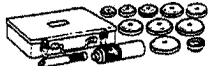

Section	Classification	Part Name	EM	EC	FI	CO	LU	ST	CH	FA	RA
Part No.	Illustration										
		(09215-00420) (Camshaft Bearing Remover & Replacer)	●								
		09215-00100 (Camshaft Bearing Remover & Replacer Set "A")	C ●								
		(09215-00130) (Bolt)	●								
		(09215-00140) (Nut)	●								
		(09215-00150) (Shaft "A")	●								
		(09215-00160) (Pin)	●								
		(09215-00240) (Remover & Replacer)	●								
		(09215-00270) (Remover & Replacer)	●								
		09222-30010 (Connecting Rod Bushing Remover & Replacer)	B ●								
		09223-50010 (Crankshaft Front Oil Seal Replacer)	B ●								
		09223-60010 (Crankshaft Rear Oil Seal Replacer)	B ●								
		09228-44011 (Oil Filter Wrench)	A				●				

# SST (SPECIAL SERVICE TOOLS) (Cont'd)

Section	Classification	Part Name	EM	EC	FI	CO	LU	ST	CH	FA	RA
Part No.	Illustration										
		<b>09236-00101</b> (Water Pump Overhaul Tool Set)	B			●					
		(09237-00010) (Water Pump Bearing Remover & Replacer)				●					
		(09237-00050) (Shaft "B")				●					
		<b>09238-47012</b> (Water Pump Bearing Remover & Replacer)	B	*1							
		<b>09258-14010</b> (Air Pump Tester)	A		●						
		<b>09268-41045</b> (Injection Measuring Tool Set)	B			●					
		<b>09268-45012</b> (EFI Fuel Pressure Gauge)	A			●					
		<b>09285-76010</b> (Injection Pump Camshaft Bearing Cone Replacer)	C					●	*2		
		<b>09286-46011</b> (Injection Pump Spline Shaft Puller)	C					●	*3	●	*4
		<b>09308-00010</b> (Oil Seal Puller)	A							●	
		<b>09308-10010</b> (Oil Seal Puller)	A	●							
		<b>09330-00021</b> (Companion Flange Holding Tool)	A	●							

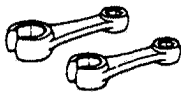
Remarks:  
 \*1 Crankshaft front oil seal  
 \*2 Armature rear bearing  
 \*3 Armature bearing  
 \*4 Rotor rear bearing

# SST (SPECIAL SERVICE TOOLS) (Cont'd)

Section	Classification	Part Name	EM	EC	FI	CO	LU	ST	CH	FA	RA
	09607-60020	(Front Wheel Adjusting Nut Wrench)	A							●	
	09608-35014	(Axle Hub & Drive Pinion Bearing Tool Set)	B							●	
	(09608-06020)	(Handle)								●	
	(09608-06150)	(Rear Hub Outer Bearing Cup Replacer)								●	
	(09608-06200)	(Rear Axle Bearing Replacer)								●	
	(09608-06210)	(Rear Axle Bearing Replacer)								●	
	09631-22020	(Power Steering Hose Nut 14 x 17 Wrench)	A		● <sup>*1</sup>						
	09751-36011	(Brake Tube Union Nut 10 x 12 Wrench)	A							●	
	09842-30050	(Wiring "A" EFI Inspection)	B		●						
	09842-30070	(Wiring "F" EFI Inspection)	B		●						

Remarks:

\*1 Fuel line flare nut

NOTE: For reference to SSTs for the Air Conditioning System see page AC-2.

**SSM (SPECIAL SERVICE MATERIALS)**

Part Name	Part No.	Sec.	Use etc.
Seal packing or equivalent	08826-00080	EM	Main bearing caps No. 1 and No. 4
Adhesive 1324, Three bond 1324 or equivalent	08833-00070	EM	Drive plate mount bolt
Adhesive 1344, Three bond 1344, Loctite 242 or equivalent	08833-00080	EM	Timing gear cover





# ELECTRICAL WIRING DIAGRAMS

## HOW TO READ THIS SECTION

### PIN NUMBER

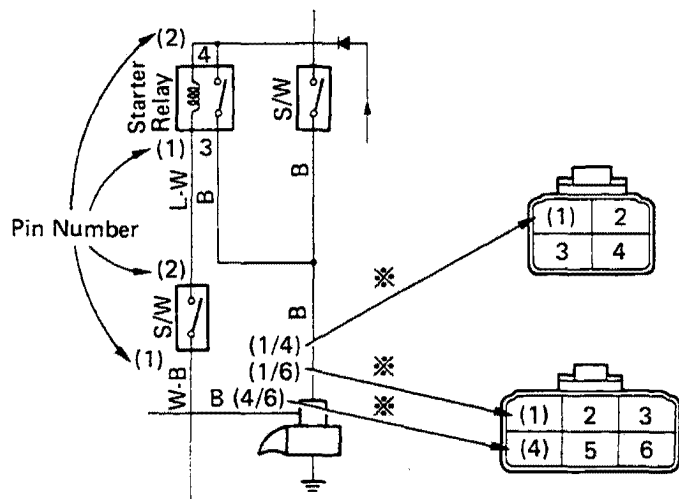

Numbered in order from upper left to lower right

Numbered in order from upper right to lower left

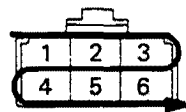

Female

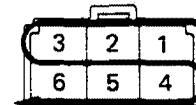

Male

BE0832

Male & female connectors distinguished by shape of their internal pins.

- All connectors are shown from the open end, and the lock is on top.

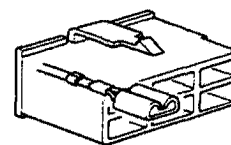

Female

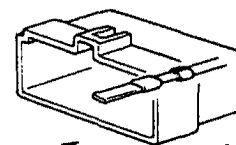

Male

BE0833

※ When connectors with different numbers of terminals are used with the same parts, the pin number and the numbers of terminals are specified.  
e.g. (1/4) = No. 1 pin/4 terminals connector

### JUNCTION BLOCK OR RELAY BLOCK

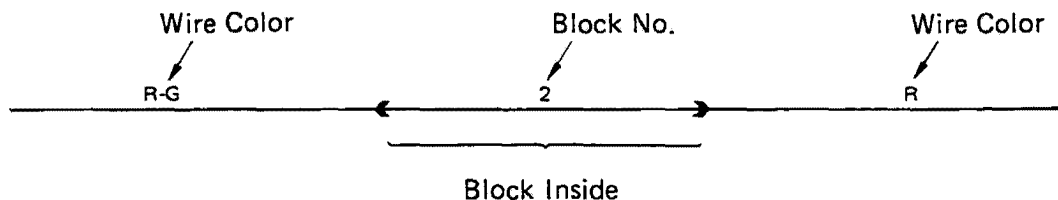

### WIRE COLOR

Wire colors are indicated by an alphabetical code.

B = Black	BR = Brown	G = Green	GR = Gray	L = Blue
LG = Light Green	O = Orange	P = Pink	R = Red	V = Violet
W = White	Y = Yellow			

The 1st letter indicates the basic wire color and the 2nd indicates the stripe color.

Example: R-G indicates a Red wire with a Green stripe.

### ABBREVIATION































The following abbreviations are used in this wiring diagram.

A/C = Air Conditioner	RH = Right-hand
A/T = Automatic Transmission	S/W = Switch
CB = Circuit Breaker	VSV = Vacuum Switching Valve
ECU = Electronic Controlled Unit	w/ = With
EFI = Electronic Fuel injection	w/o = Without
FPU = Fuel Pressure Up	2WD = 2 Wheel Drive
ISC = Idle Speed Control	4WD = 4 Wheel Drive
LH = Left-hand	

# SYSTEM INDEX

LAND CRUISER

1988 Model (Page 1 to Page 4)

SYSTEMS	LOCATION	SYSTEMS	LOCATION
Air Conditioner, Cooler and Heater	 2-1	Power Windows	 3-7
Auto Antenna	 4-4	Radio and Tape Player	 4-4
A/T Fluid Temp. Warning	 2-5	Rear Air Conditioner	 2-3
Back-up Lights	 2-8	Rear Window Defogger	 4-1
Charging	 1-6	Rear Wiper and Washer	 2-7
Cigarette Lighter	 4-3	Remote Control Mirrors	 4-5
Clock	 4-3	Starting	 1-2
Combination Meter	 2-4	Stop Lights	 3-1
Cooling Fan (Engine)	 4-7	Taillights and Illumination	 3-4
Door Locks	 3-6	Unlock and Seat Belt Warning	 4-1
EFI	 1-3	Turn Signal and Hazard	 3-2
Front Wiper and Washer	 2-6	4WD	 1-8
Headlight Cleaner	 2-8		
Headlights	 3-5		
Horn	 3-3		
Ignition	 1-5		
Interior Lights	 4-2		
Power Source	 1-1		

# LAND CRUISER ELECTRICAL WIRING DIAGRAM-1988 Model (Page 1 to Page 4)

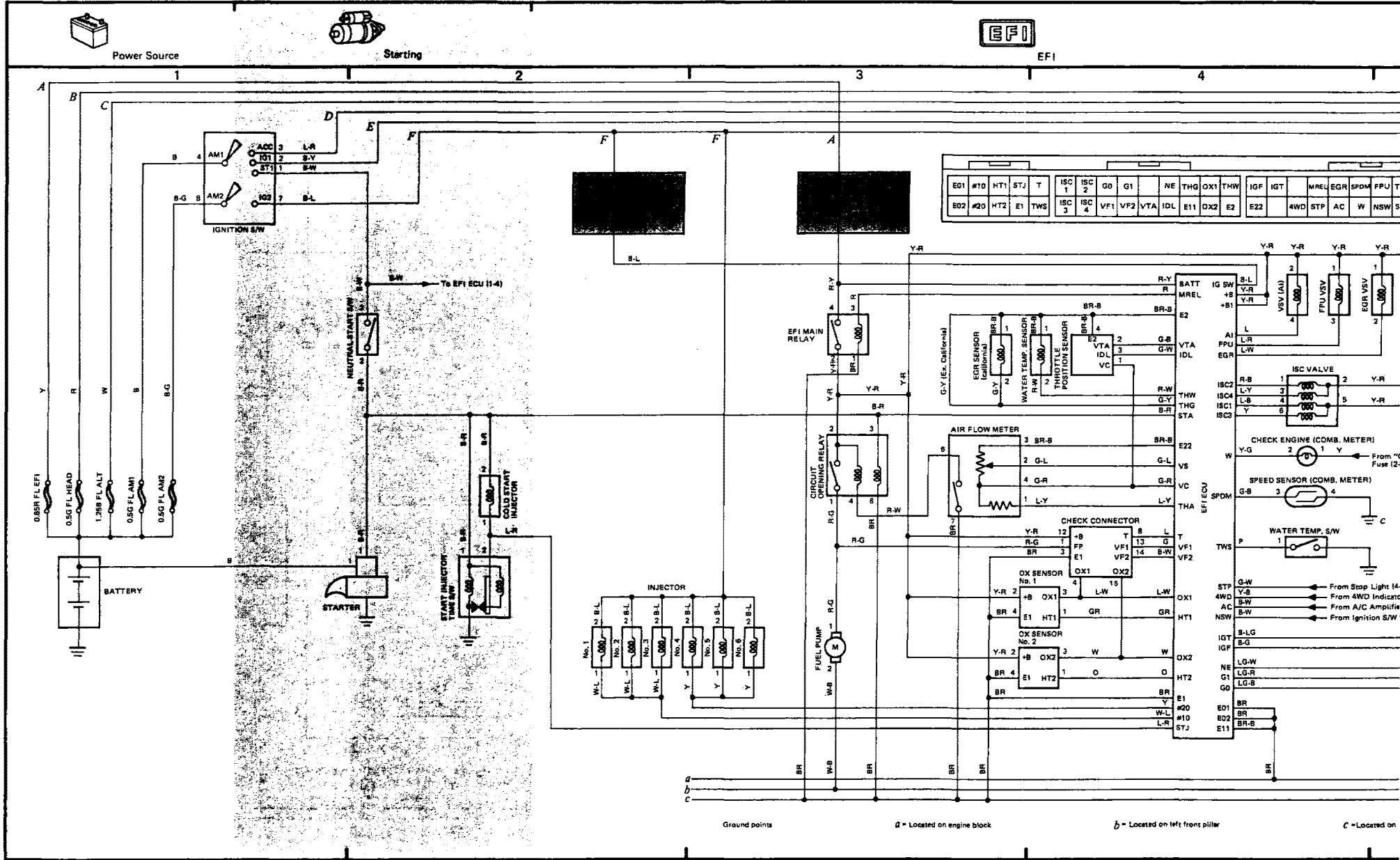



# 2 LAND CRUISER (Cont'd)



Air Conditioner, Cooler and Heater



Rear Air Conditioner



Combination Meter

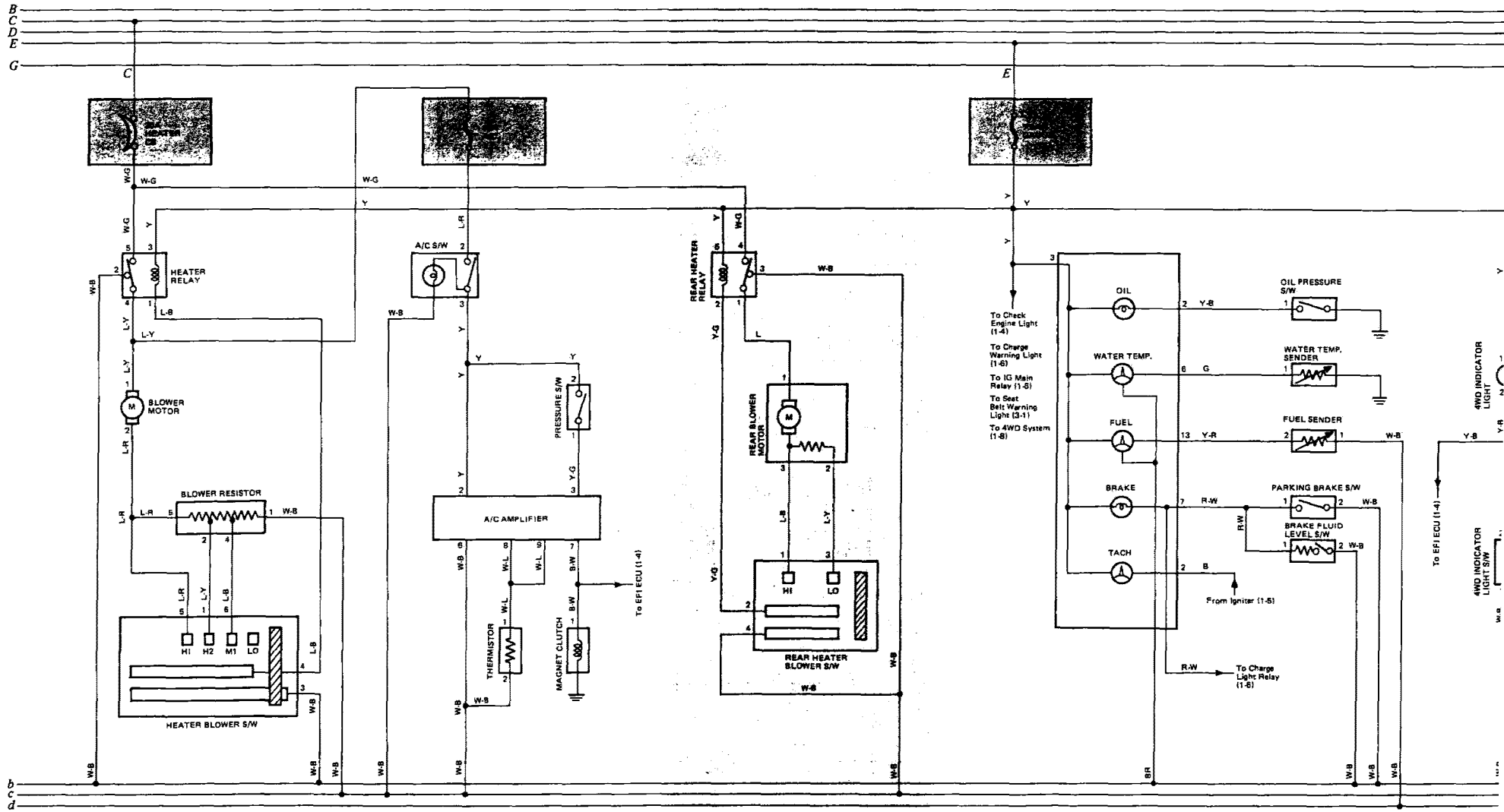

Ground points

b = Located on left front pillar

c = Located on right front pillar

d = Located on corner of back panel



# LAND CRUISER (Cont'd)



Unlock and Seat Belt Warning



Turn Signal and Hazard



Horn



Taillights and Illumination

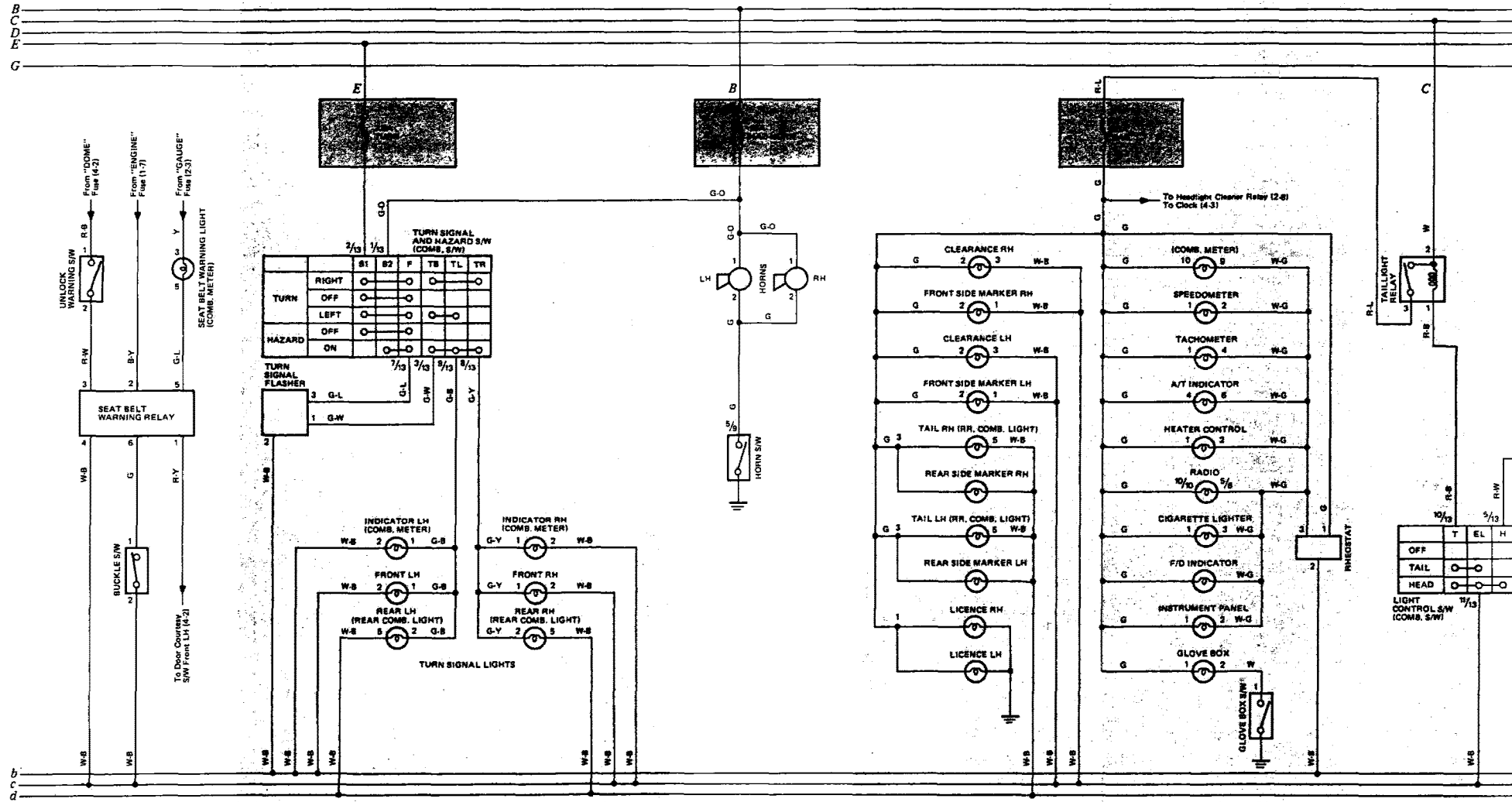

Ground points

*b* = Located on left front pillar

*C* = Located on right front pillar

*d* = Located on center of back panel



Headlights



Door Locks



Power Windows

5

6

7

8

B  
C  
D  
E  
C

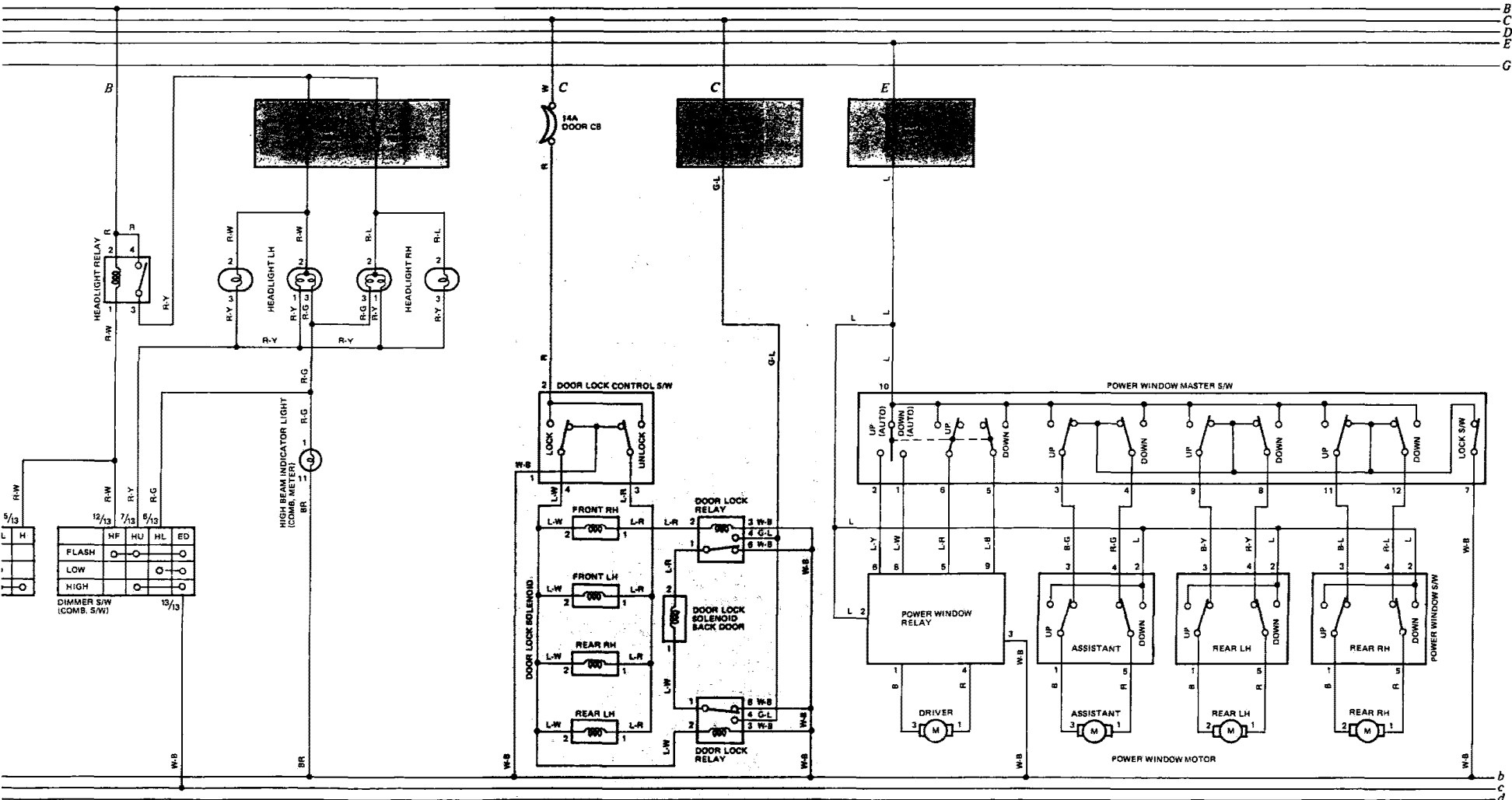

b  
c  
d

# 4 LAND CRUISER (Cont'd)



Stop Lights



Rear Window Defogger



Interior Lights



Clock



Cigarette Lighter



Auto Antenna



Radio and Tape

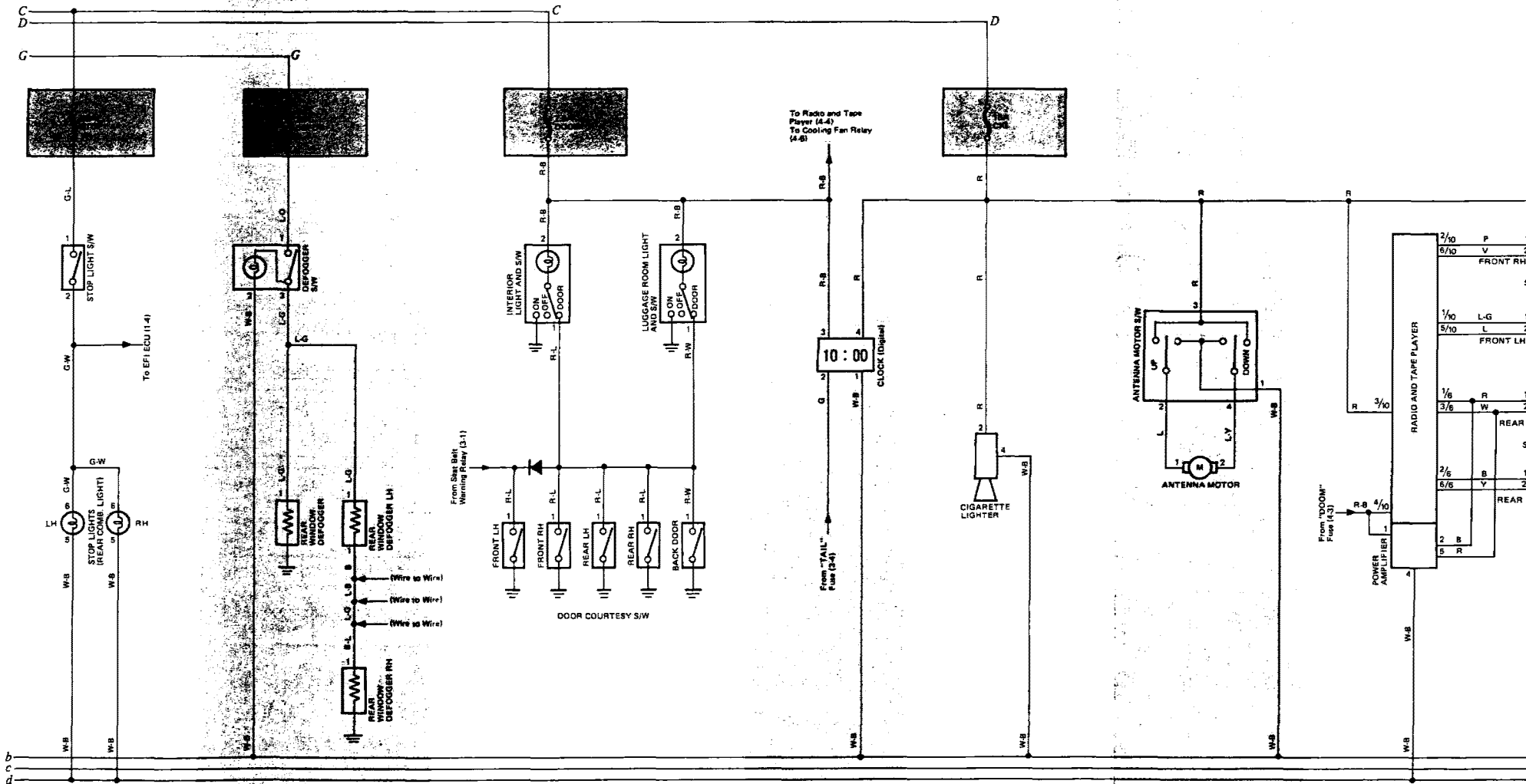

Ground points

b = Located on left front pillar

c = Located on right front pillar

d = Located on center of back panel



5

6

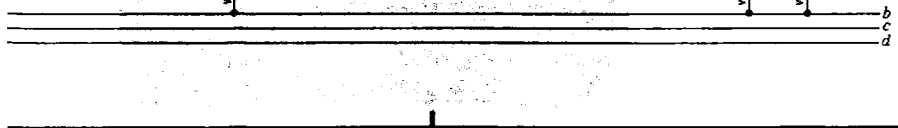
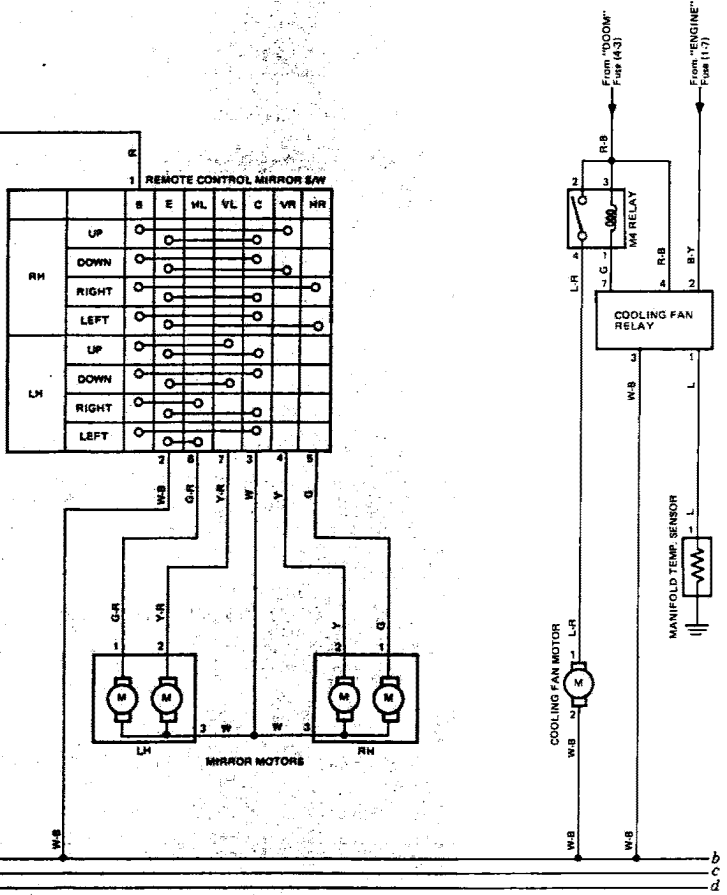

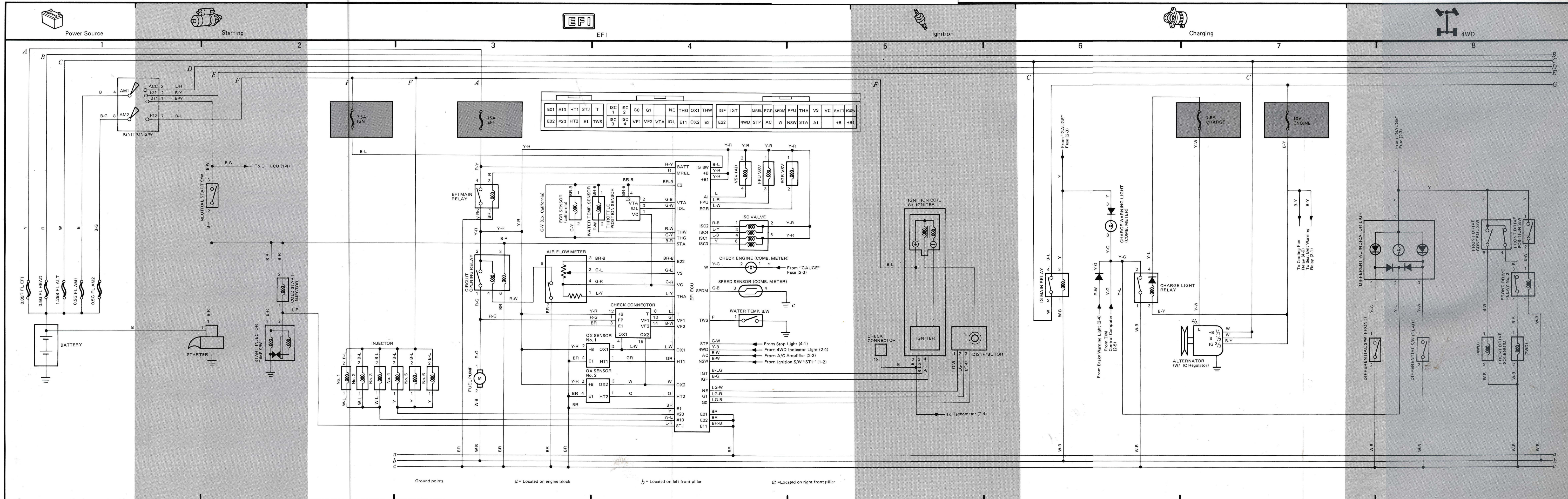

2 LAND CRUISER (Cont'd)

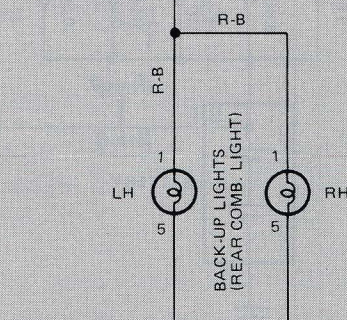
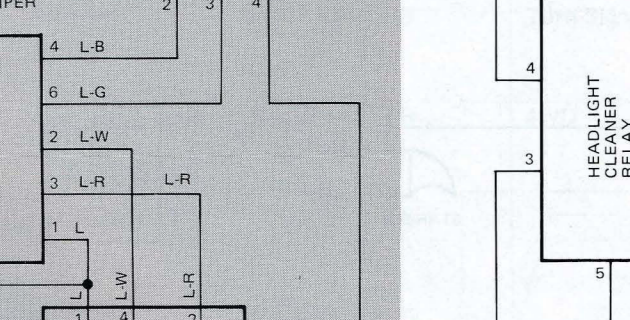
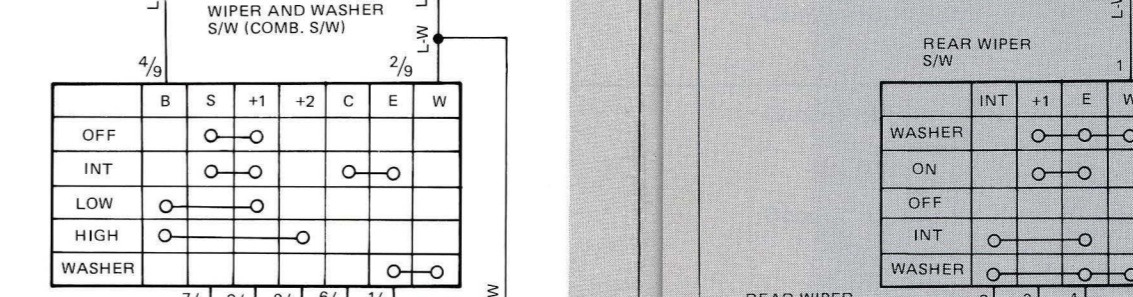
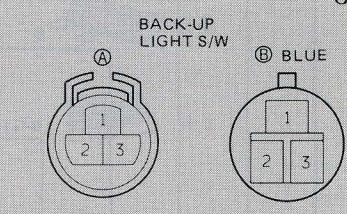
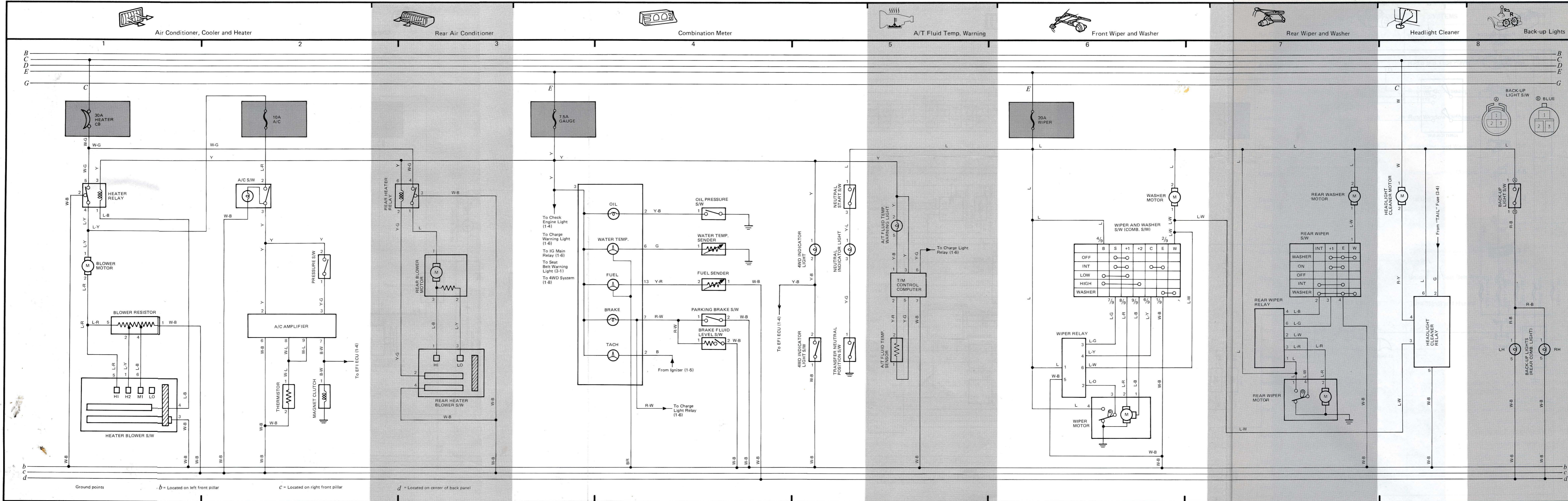

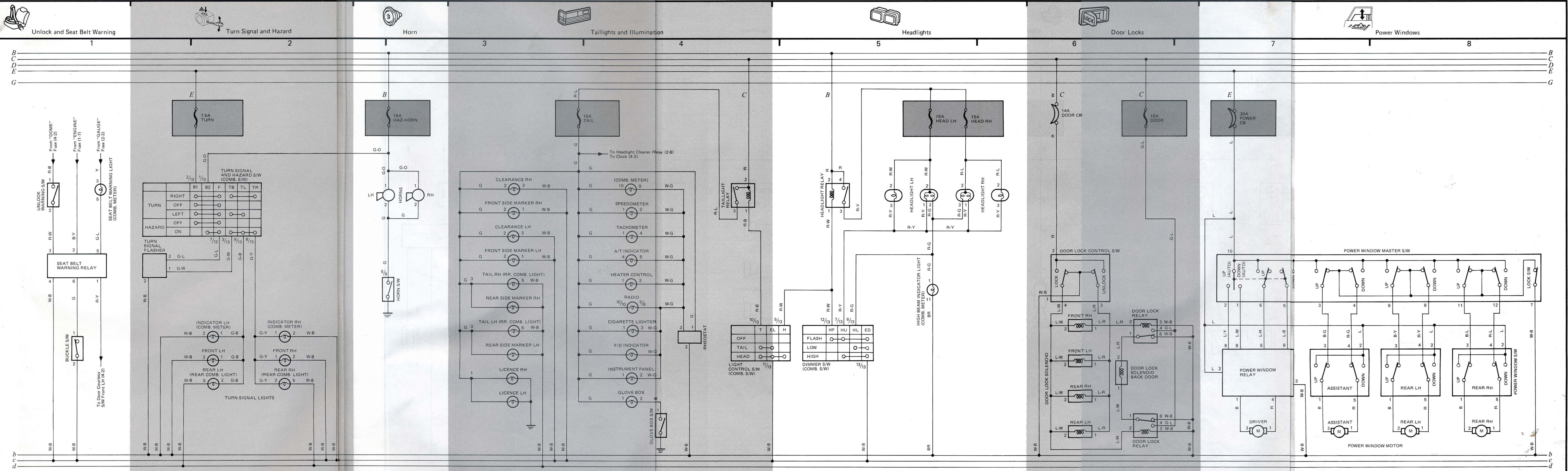

### 4 LAND CRUISER (Cont'd)

