

TOYOTA
LAND CRUISER
AIR CONDITIONER

ALL SEASON TYPE / FJ60RV Series

INSTALLATION INSTRUCTIONS

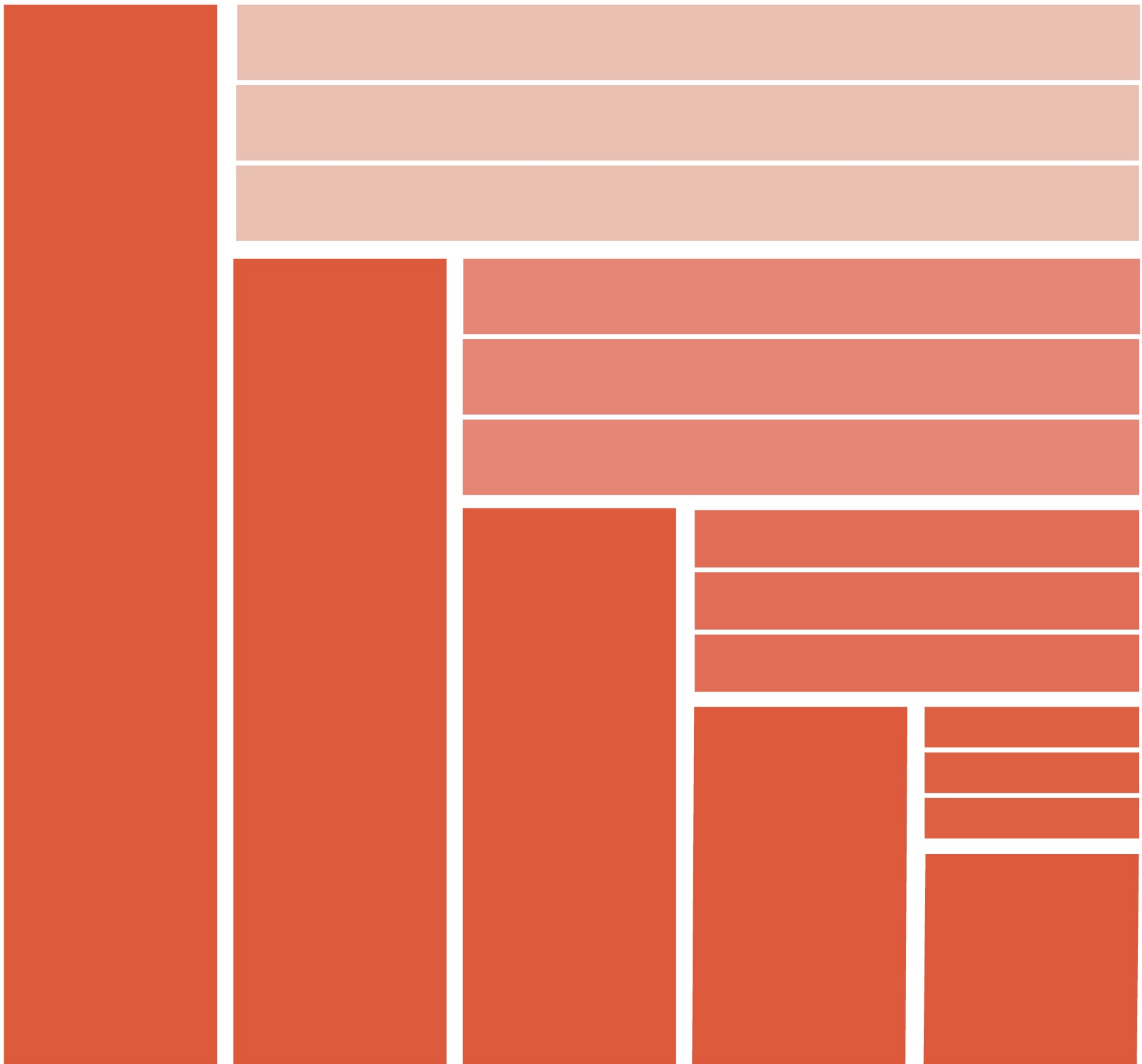

FOREWORD

This manual has been published to explain how to install the air conditioner for TOYOTA LAND CRUISER and how to charge the air conditioning system with refrigerant. When installing the air conditioner, installation should be done as described in this manual.

Improper installation will reduce its performance and function of vehicle.

TABLE OF CONTENTS

I	GENERAL INFORMATION	1
II	INSTALLATION	3
II-1	INSTALLATION INSIDE PASSENGER COMPARTMENT	3
II-2	INSTALLATION INSIDE ENGINE COMPARTMENT	7
II-3	PIPING	12
II-4	ENGINE IDLE SPEED CONTROL DEVICE	15
II-5	WIRING	17
III	WIRING DIAGRAM	18
IV	FINISH	19

I GENERAL INFORMATION

1. PREPARATION BEFORE INSTALLATION

1-1 Adjustment and Inspection of the Car

Prior to installing the air conditioner, make the following inspections and/or adjustments.

- 1) Engine Ignition Timing
- 2) Engine Cooling System
- 3) Battery Electrolyte and Charging System
- 4) Passenger Compartment Seal
- 5) Fuel System
- 6) General Car Inspection

1-2 Preparation of Air Conditioner Parts

When unpacking the parts kit, lay parts out in order of installation.

Check entire contents of kit for missing or defective components.

When installing the air conditioner, use the fender covers and seat covers to protect the fender and seat.

1-3 Tools for Installation

- | | |
|----------------------------------|-----------------------------|
| 1) Vacuum Pump | 3) Torque Wrench |
| 2) Air Conditioner Service Tools | 4) Automobile Service Tools |

2. SERVICE PRECAUTION

- 1) Disconnect the ground cable at the battery negative terminal.
- 2) Parts mounted on the engine must use bolts provided in kit and be torqued to specifications.
- 3) When installing air conditioning lines and A/C wire harness, route properly to avoid interference with surrounding parts.
- 4) Before making any hose and tube connections, apply a few drops of refrigeration oil to the seat of flare nuts.
- 5) When tightening or loosening line fittings, use two wrenches for equalized support.

- 6) Tighten coupling nuts according to specified torque.
O-ring fitting is introduced on 1981 Model Air Conditioner.

Standard Torque for O-ring Fitting.

Size of Flare Nut	Fixing Torque
3/8 inch tube for liquid line	1.2 – 1.5 kg-m (12 – 15 N-m)
1/2 inch tube for discharge line	2.0 – 2.5 kg-m (20 – 25 N-m)
5/8 inch tube for suction line	3.0 – 3.5 kg-m (30 – 35 N-m)

- 7) Do not remove blind plugs from fittings until each component is ready for connection.

CAUTION

Remove plugs from compressor slowly to allow refrigerant to escape. The compressor is shipped from the factory with a slight charge of refrigerant to prevent corrosion of seals.

- 8) When handling the refrigerant R-12, wear eye protection and be careful that liquid refrigerant does not contact skin.
- 9) Keep the refrigerant container (service drum) below 40°C (100°F).
Follow manufacturer's instruction.

3. WHEN INSTALLING

- 1) All instructions are given as if from driver's seat.
- 2) Figures in parenthesis indicate diameter and length of bolt stem.

Example: BOLT (6 mm : 16 mm) means a bolt which is 6 mm in diameter and 16 mm in stem length.

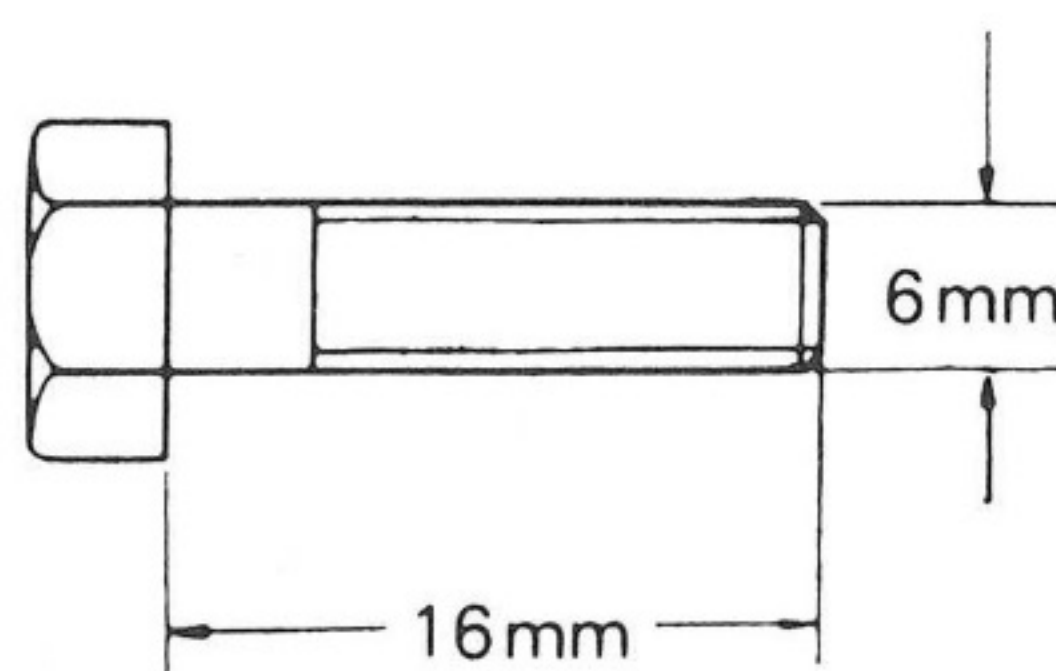

II INSTALLATION

II-1 INSTALLATION INSIDE PASSENGER COMPARTMENT

Before installing the air conditioner into the passenger compartment, the following parts must be removed.

1-1. Temporary Removal

- 1) Battery Negative Terminal
- 2) Side Air Duct
- 3) Ash Tray
- 4) Glove Box
- 5) Heater Duct

1-2. Permanent Removal

- 1) Air Duct



Fig. 1

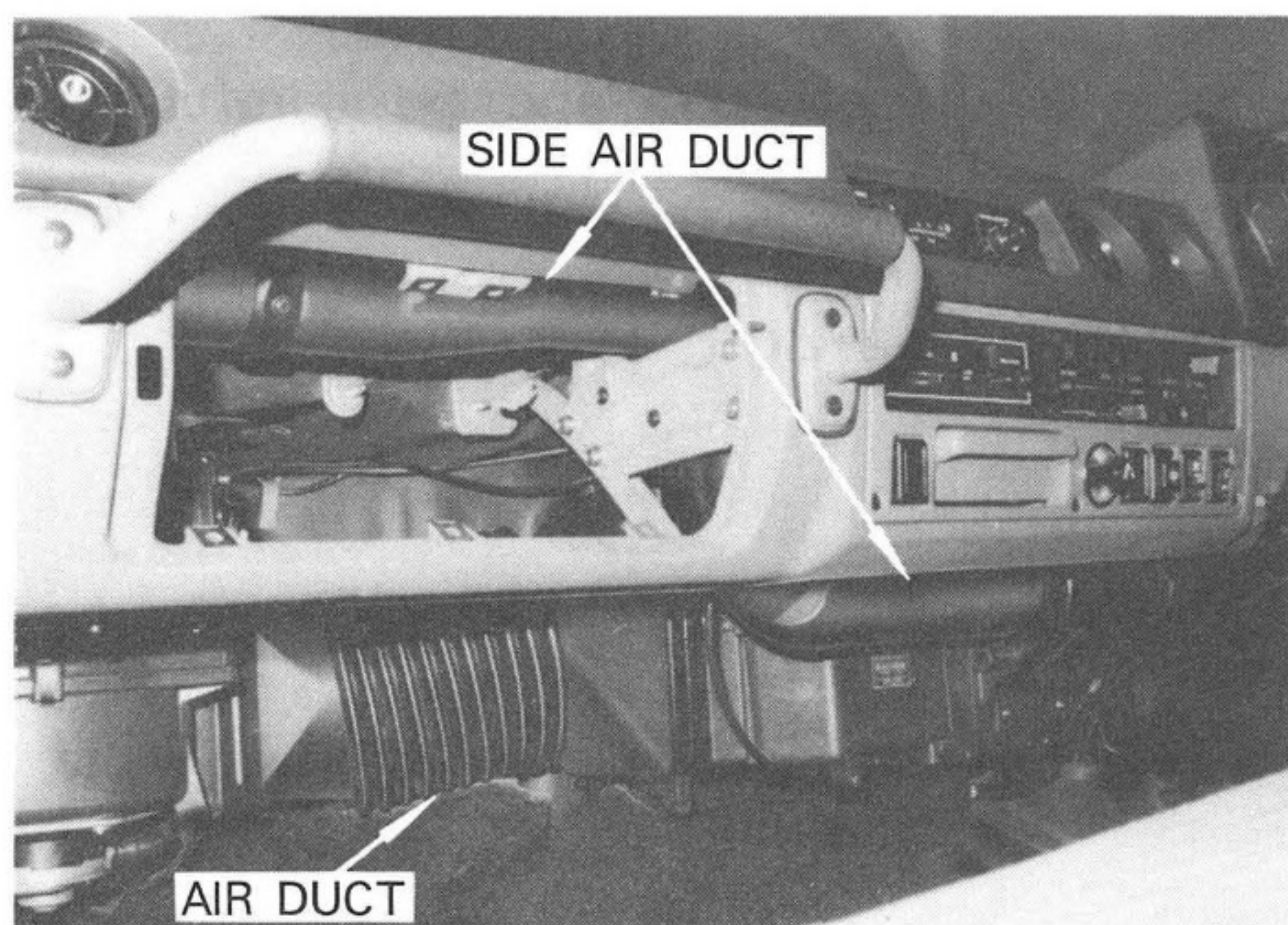

Fig. 2

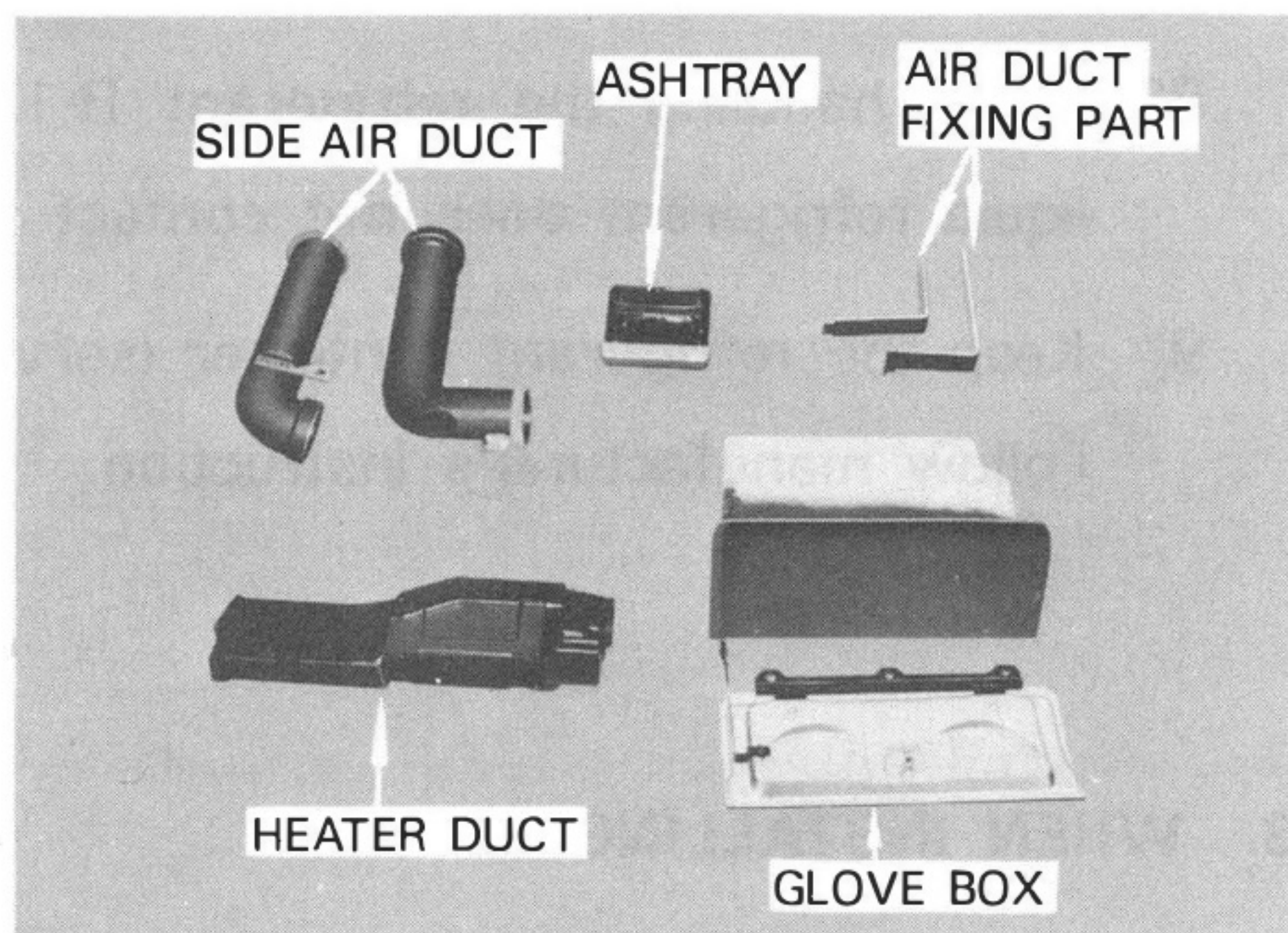

Fig. 3

2. BLIND PLUG

- A) Remove the four pieces of blind plugs from engine compartment.

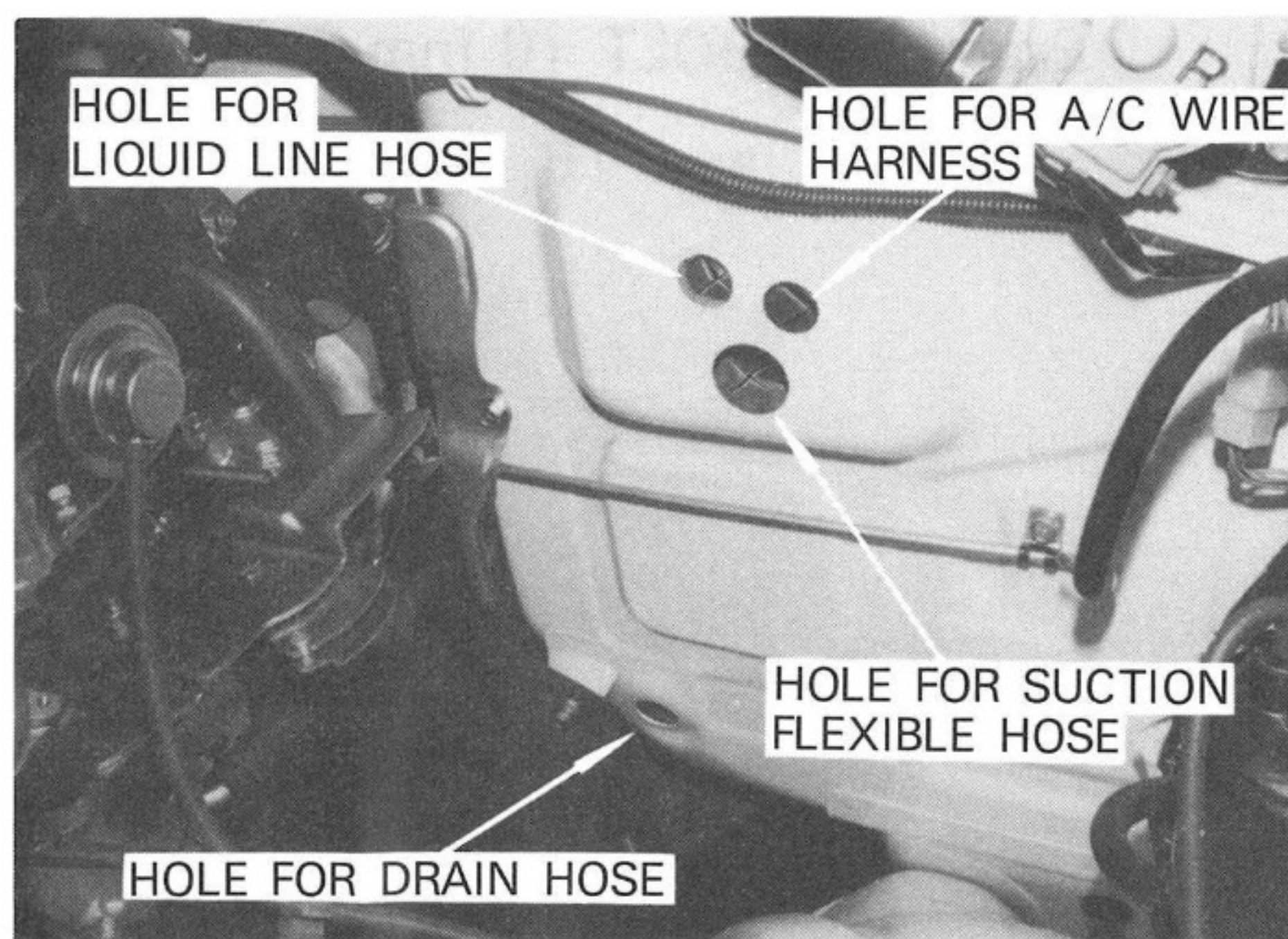

Fig. 4

3. COOLING UNIT

A) Install the A/C wire harness onto the cooling unit using clamps.

B) Connect two 2-pole and 10-pole connectors of A/C wire harness to the pressure switch, the thermistor and the amprifire.

See Fig. 5.

C) Pass the A/C wite harness of the cooling unit through the hole on the fire-wall into engine compartment.

D) Install the cooling unit using five bolts and two nuts. See Fig. 7.

E) Connect the 3-pole connectors of the A/C wire harness to the connector of car equipped harness.

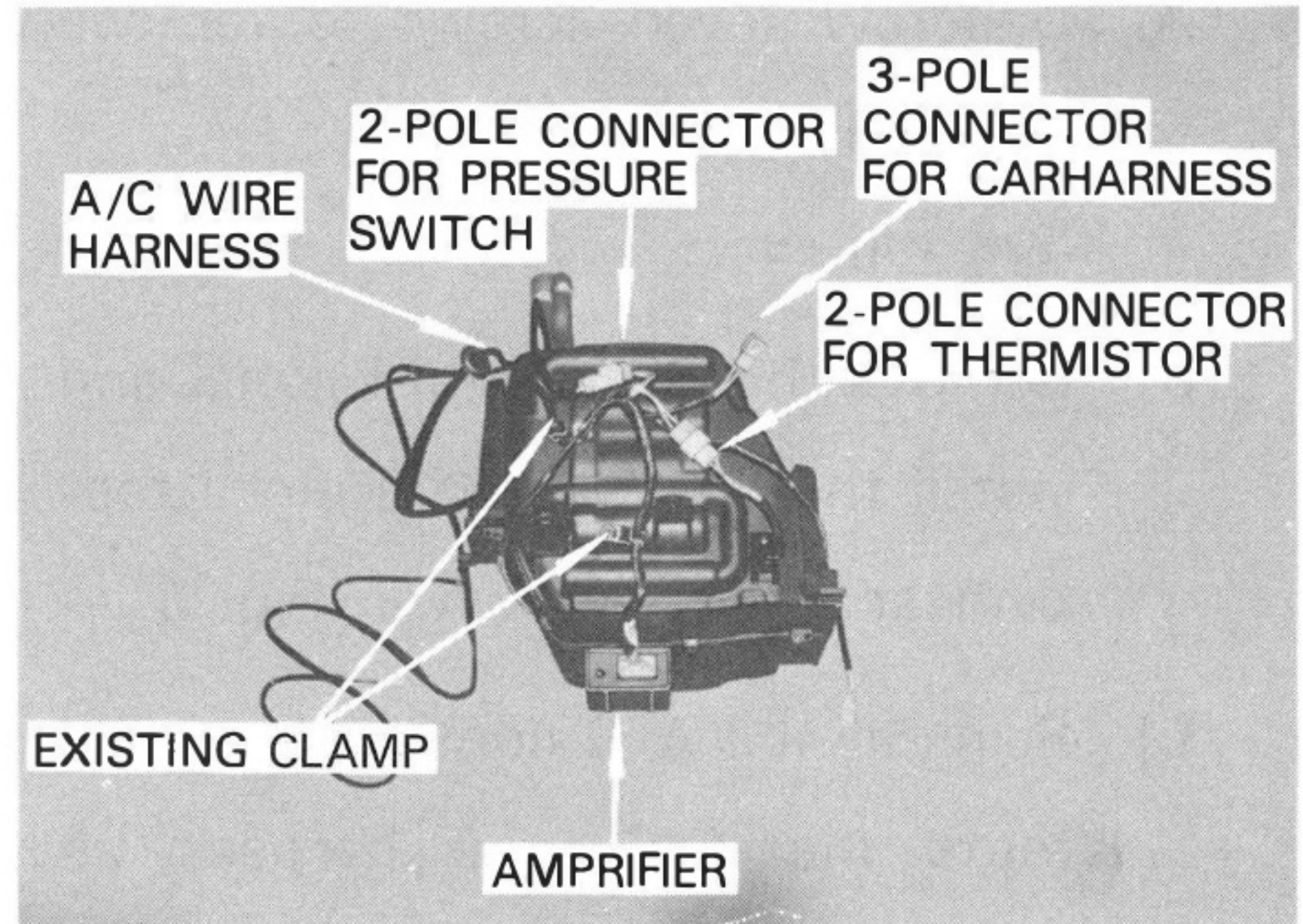

Fig. 5

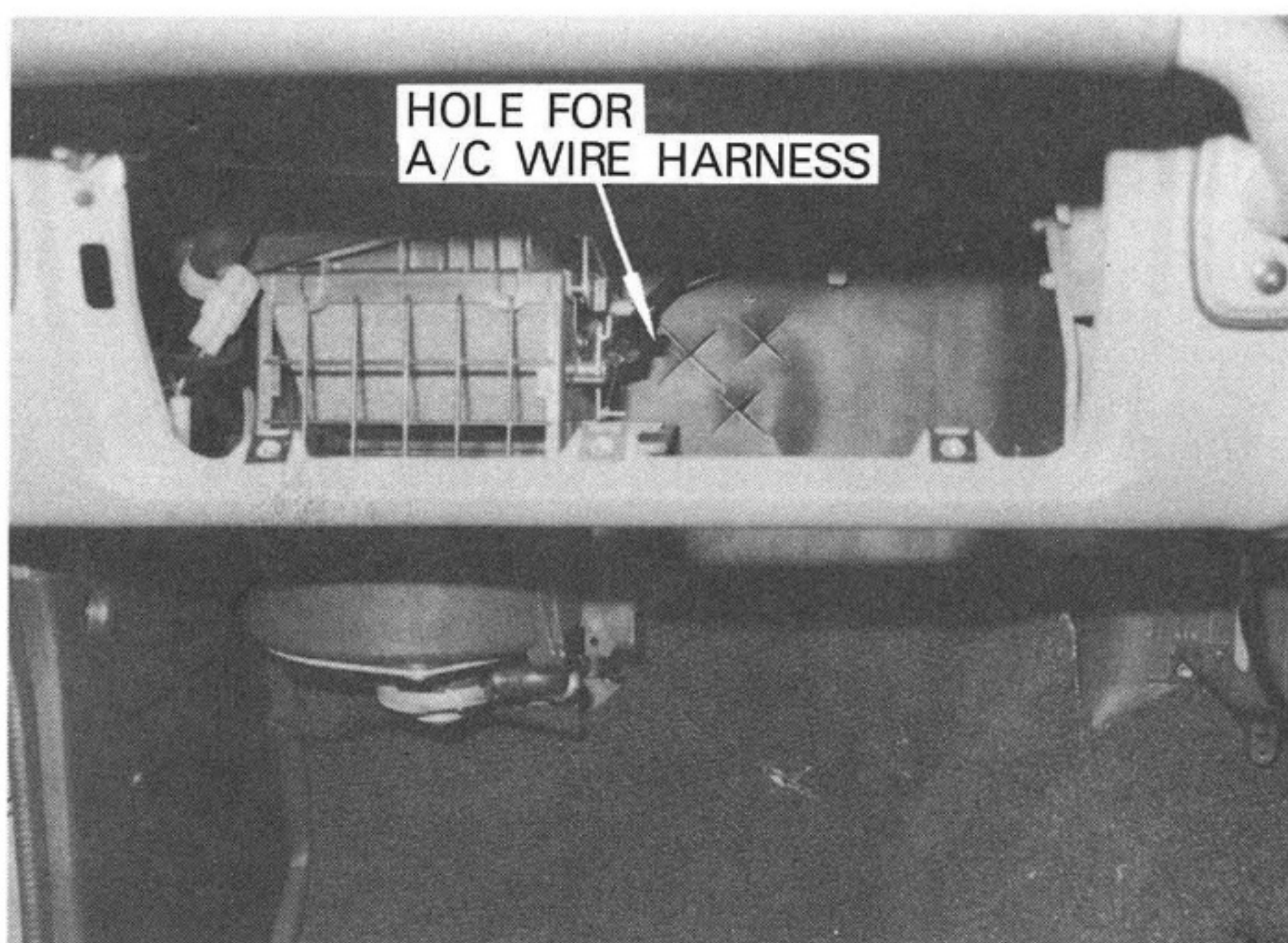

Fig. 6

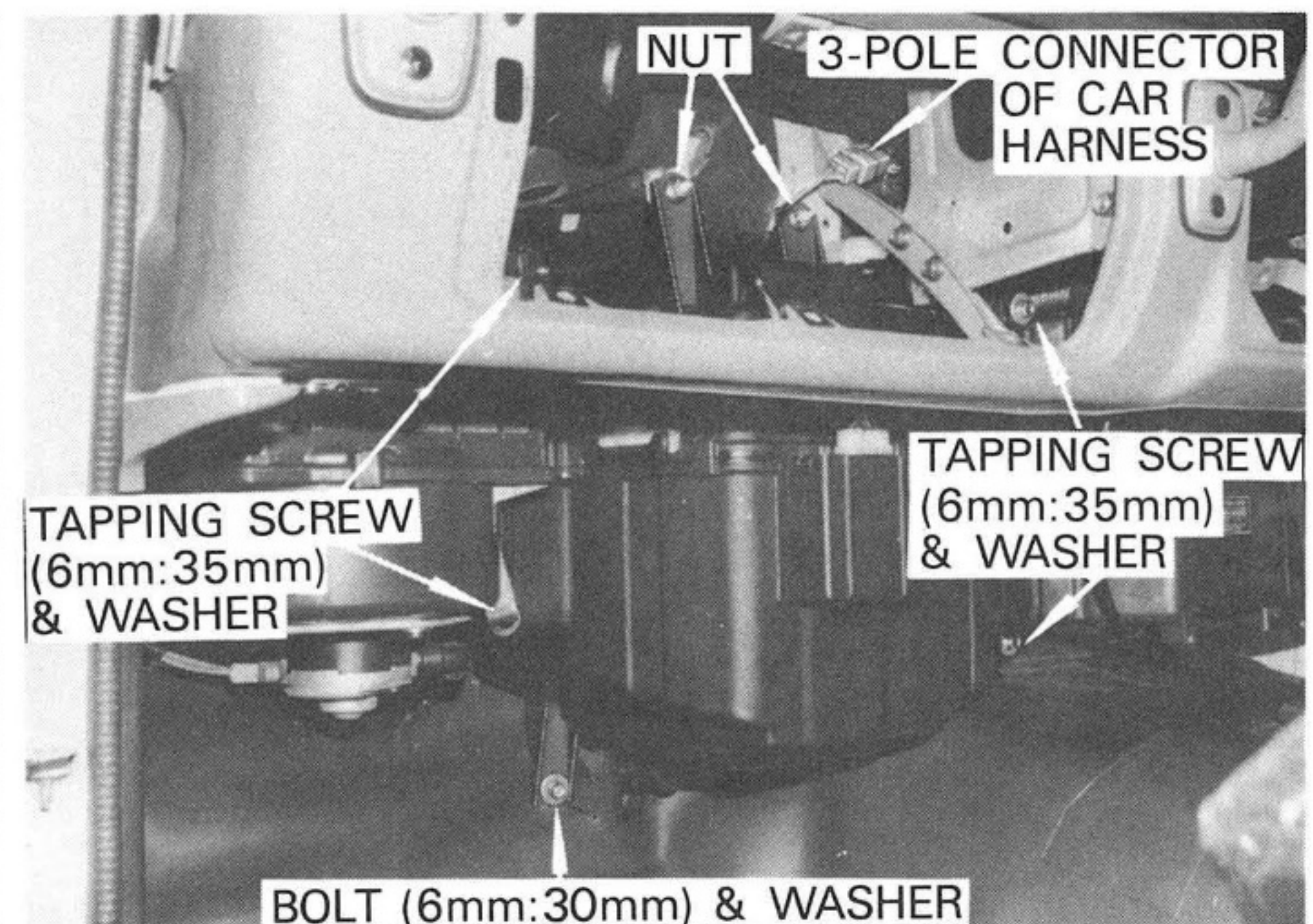

Fig. 7

F) Install the drain hose to the cooling unit and lead it into engine compartment.

G) Put the four rubber bushings into the holes for tubes, wire harness and drain hose.

See Fig. 8.

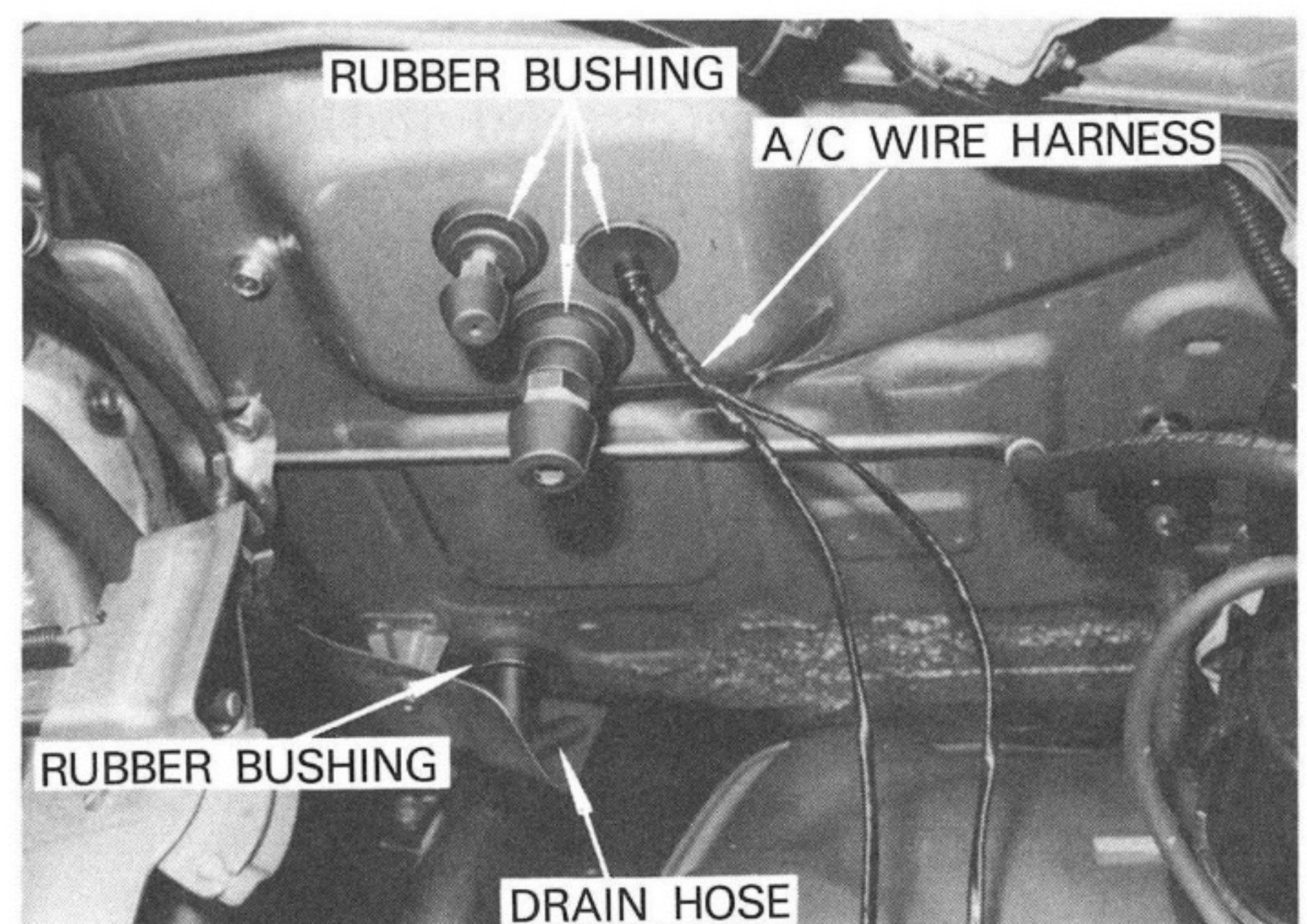

Fig. 8

4. A/C SWITCH & A/C IDLE UP SWITCH

A) Unscrew seven screws to remove the control panel ass'y.
See Fig. 9.

B) Remove the A/C control panel and install the A/C switch using a tapping screw as shown in Fig. 9.

C) Reinstall the A/C control panel and route the A/C wire harness as shown in Fig. 11.

D) Remove the blind cover by the cigarette lighter to install the A/C idle up switch.
See Fig. 9 and Fig. 12.

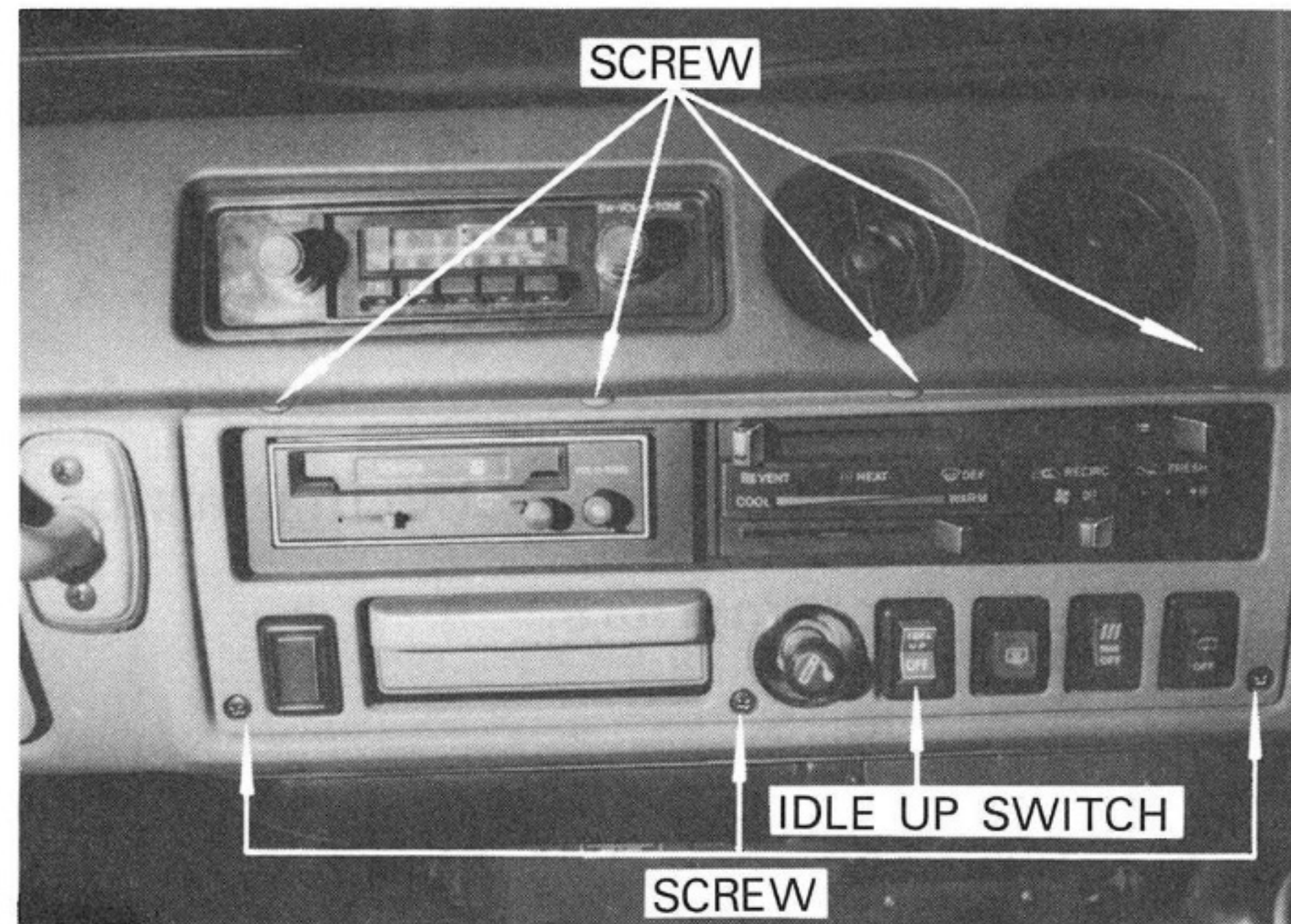

Fig. 9

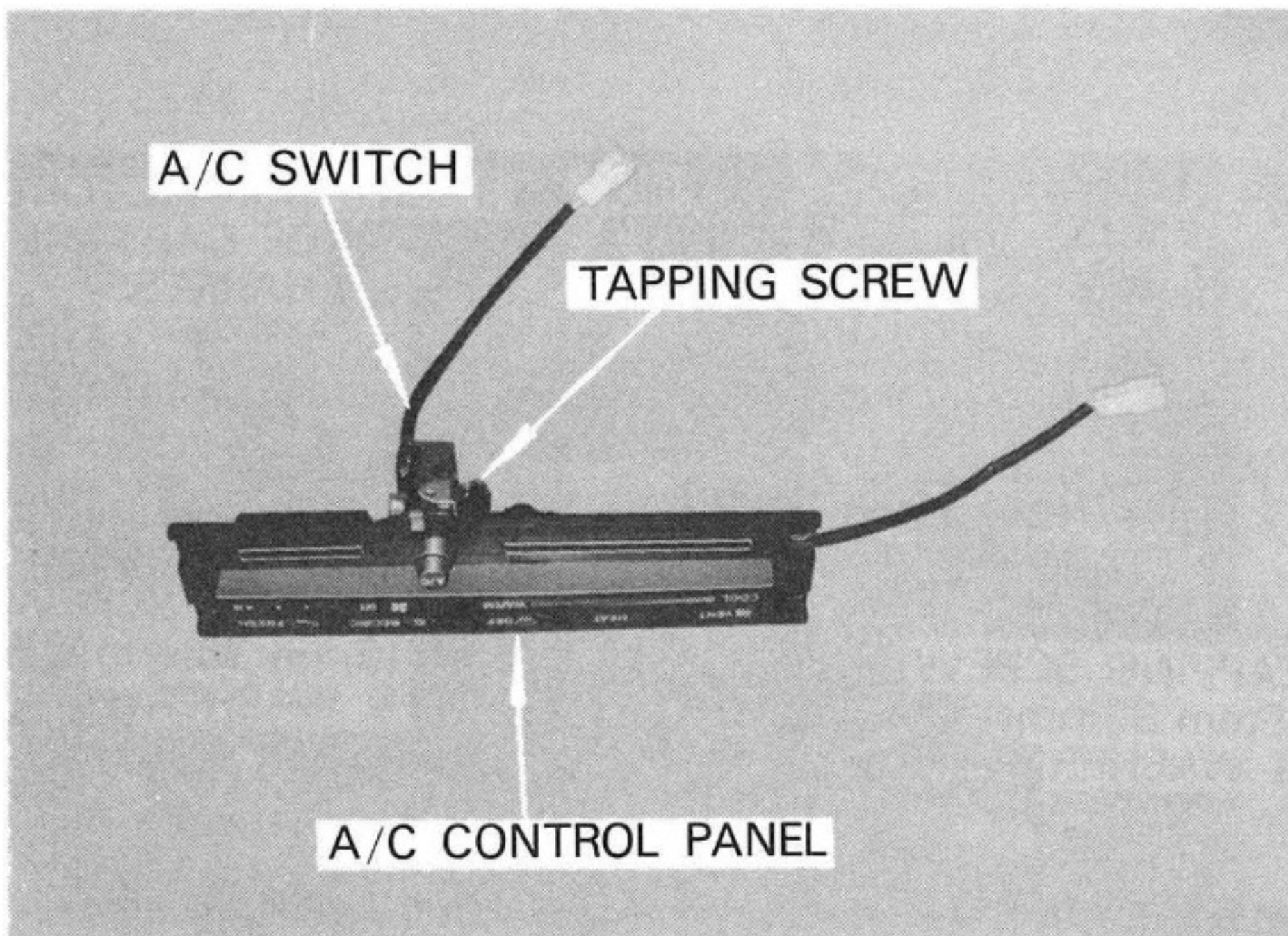

Fig. 10

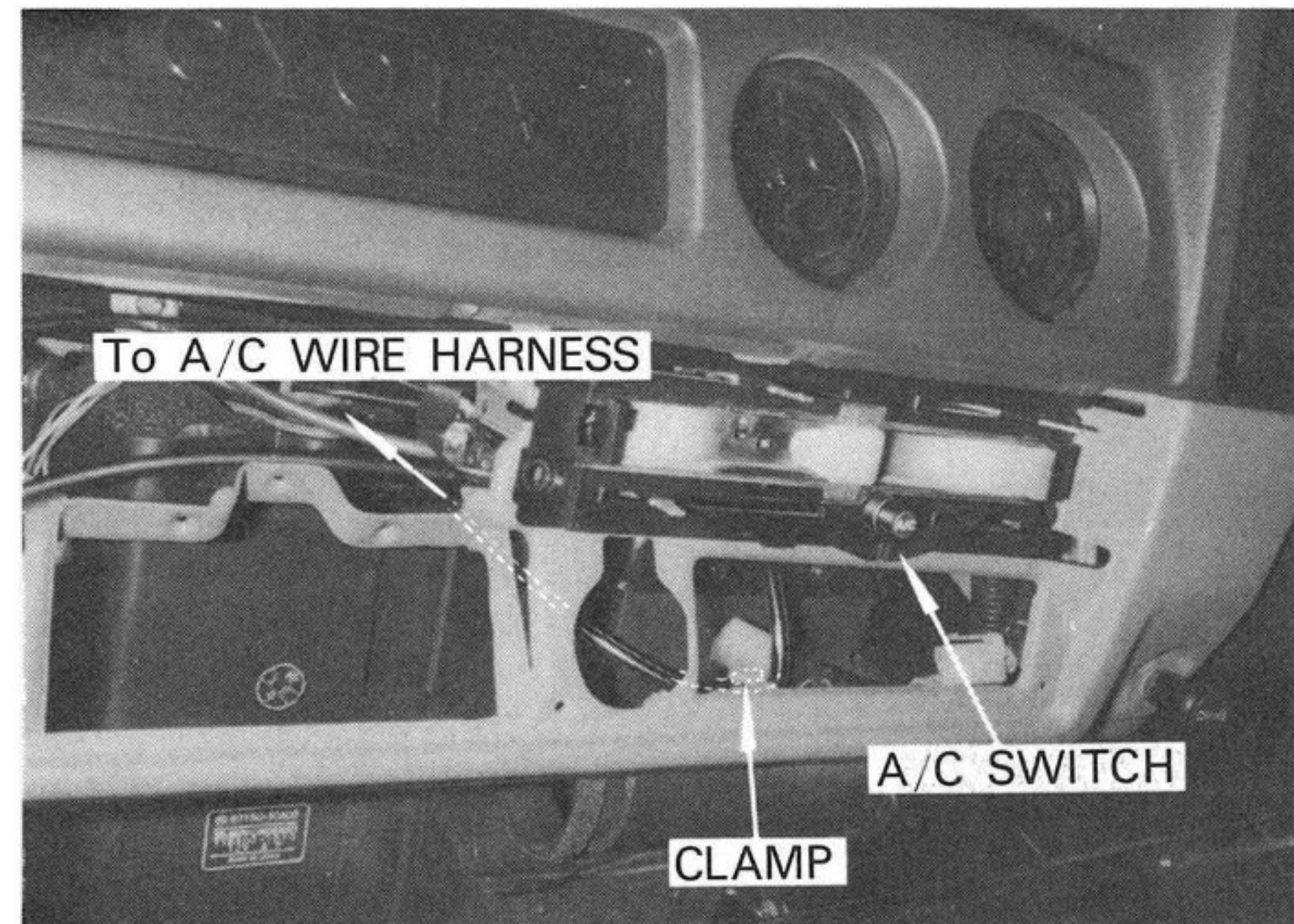

Fig. 11

E) Connect the 3-pole and 2-pole connector of A/C wire harness to the A/C switch and the A/C idle up switch. See Fig. 12.

F) Fasten the A/C wire harness using a clamp on the ash tray.

G) Reinstall the control panel ass'y, air duct and glove box at the original positions.

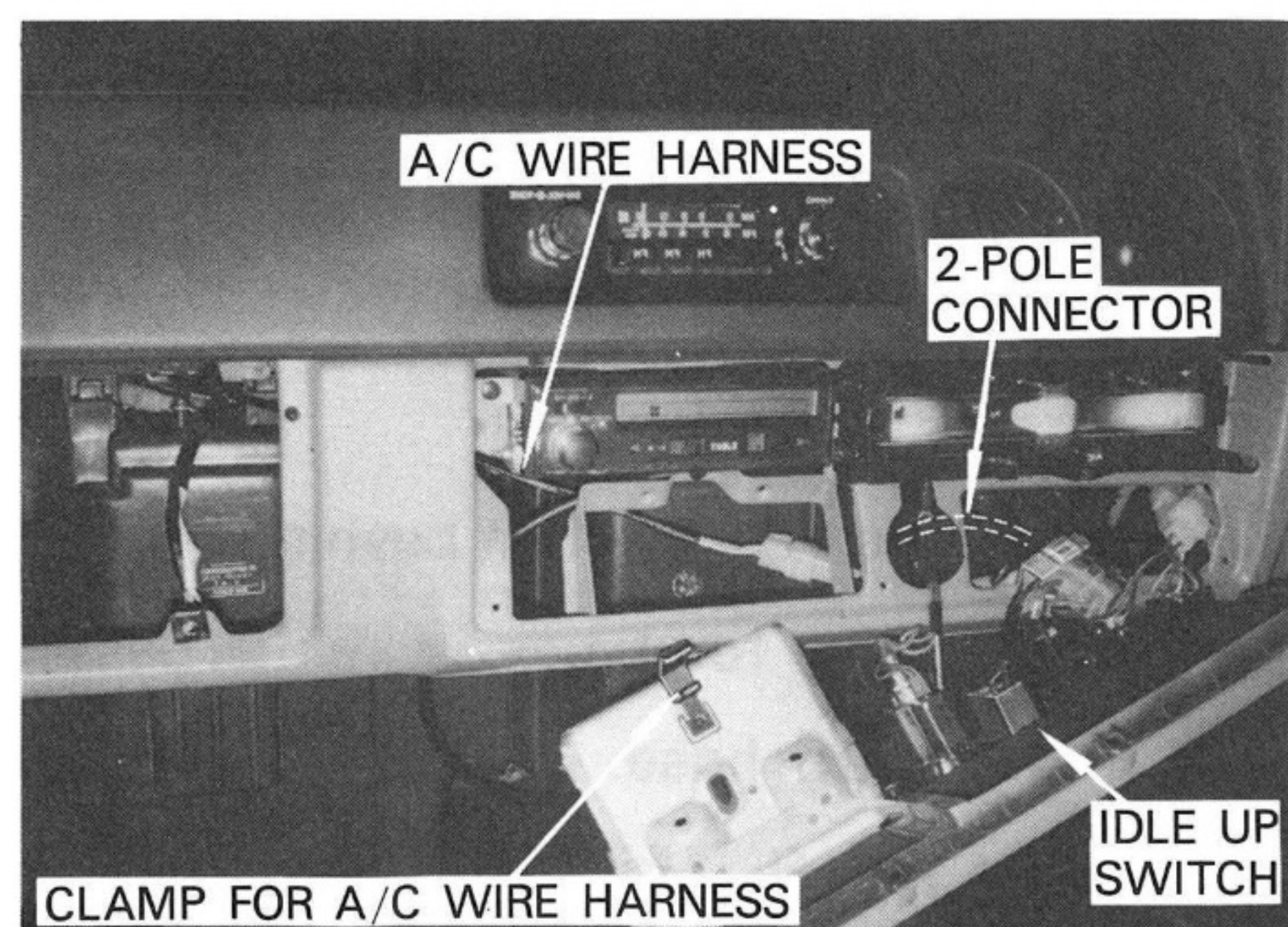

Fig. 12

Note: The A/C idle up switch is provided only for Australian model.

5. A/C RELAY

- A) Install the A/C relay at the position in Fig. 13.

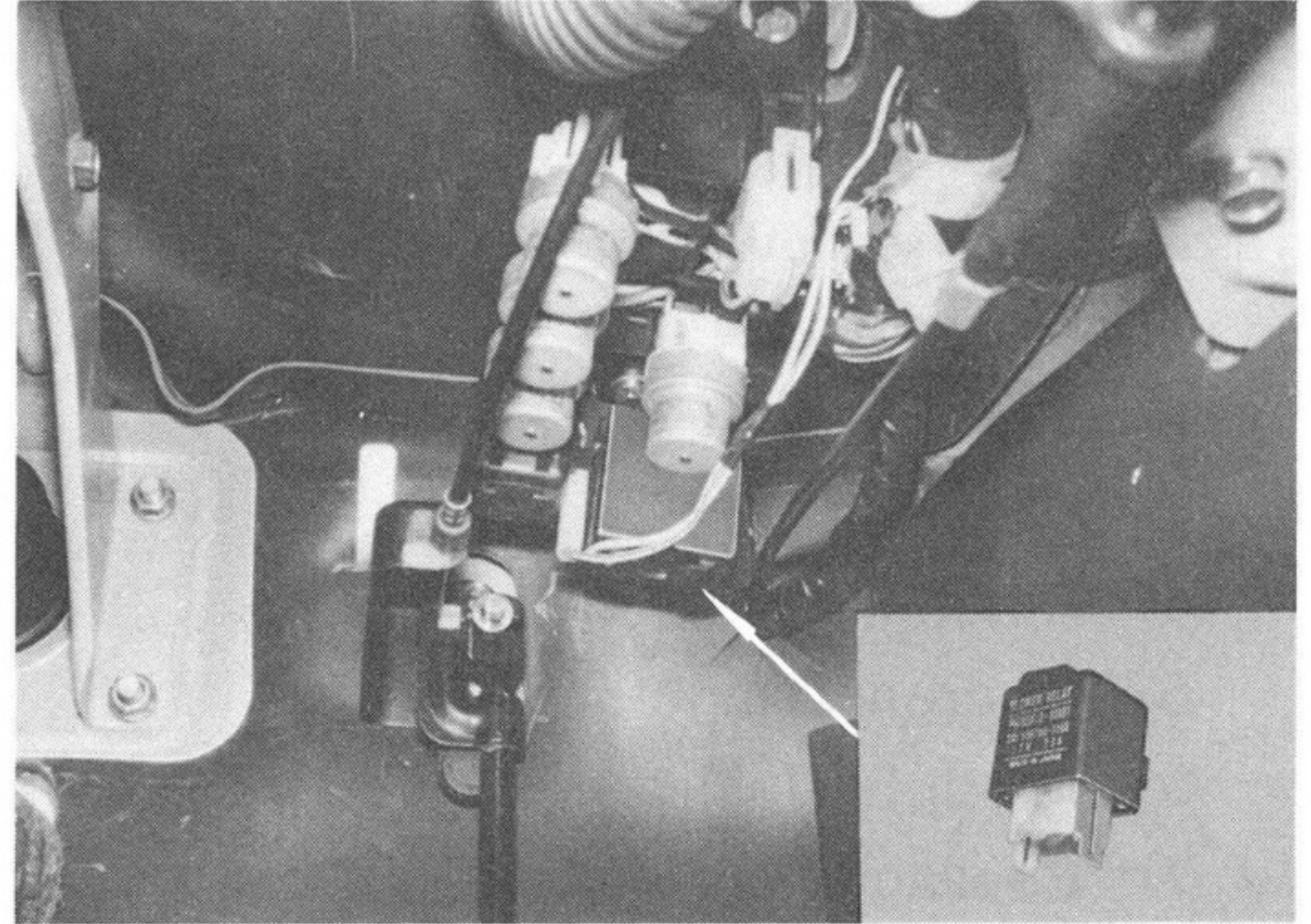

Fig. 13

II-2 INSTALLATION INSIDE ENGINE COMPARTMENT

Before installing the air conditioner into the engine compartment, the following parts must be removed.

Temporary Removal

- 1) Battery
- 2) Front Grille
- 3) Radiator
- 4) Fan Shroud
- 5) Clearance Lights
- 6) Food Lock Brace
- 7) Cooling Fan

Permanent Removal

- 1) Crankshaft Pulley
 - A) Extend lock washer.
 - B) Remove crankshaft pulley using pulley remover.
- 2) Engine Mounting Bracket (right side)

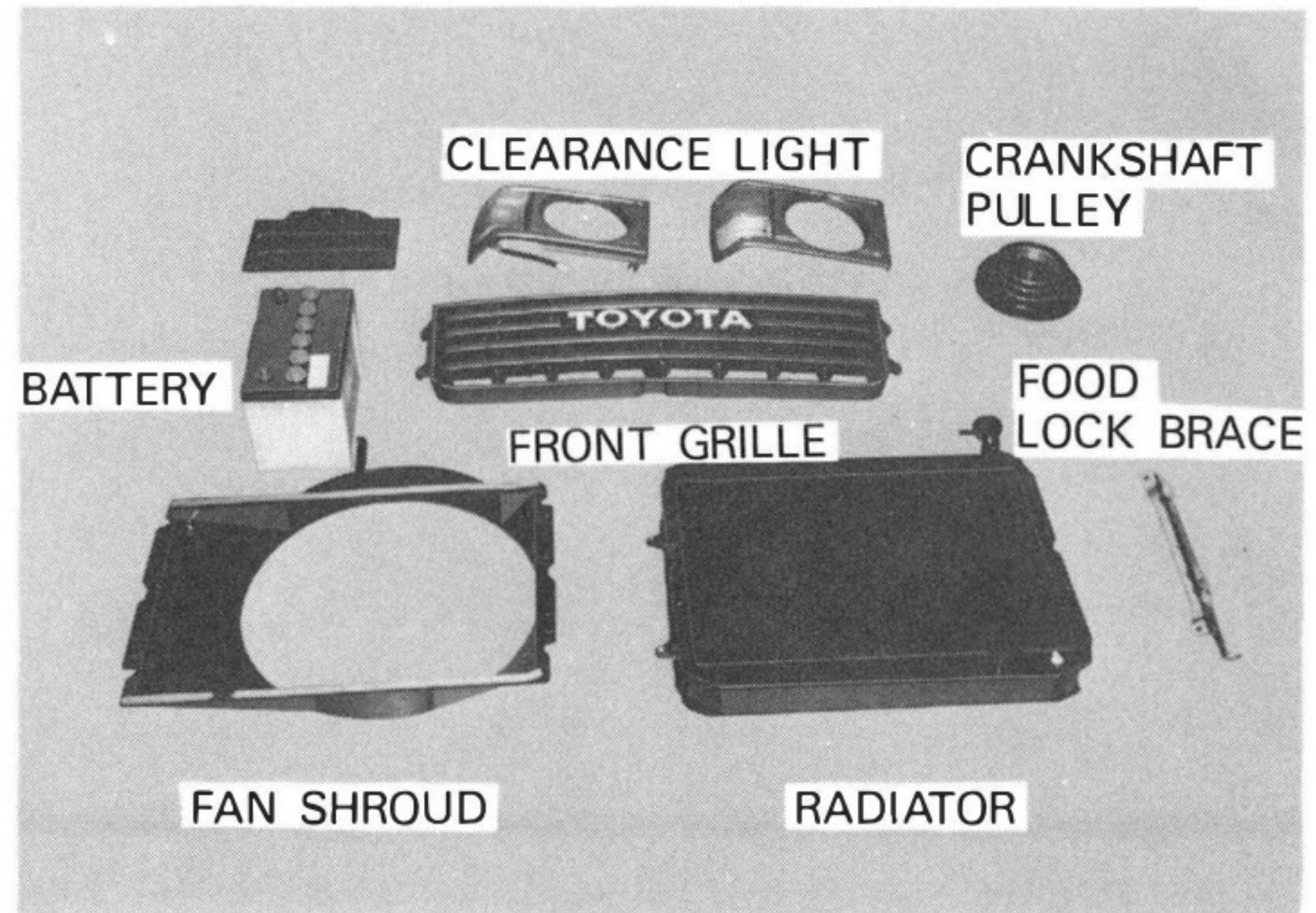

Fig. 14

1. INSTALLATION OF COMPRESSOR BRACKET

A) Threaded holes A, B, C and D are to be used to fix the compressor bracket.

The ground wire is to be fastened to the engine block using hole C.

B) Place a jack below the flywheel housing, take the weight of the engine on the jack and remove the front engine mount.

C) Install the compressor mount using holes A, B, C and D.

Bolts for A, B and C are in packet. Use original bolt and rubber mounting pad at D.

TORQUE :

7.0 – 9.0 kg-m
(50 – 65 ft-lb)

D) Remove the jack.

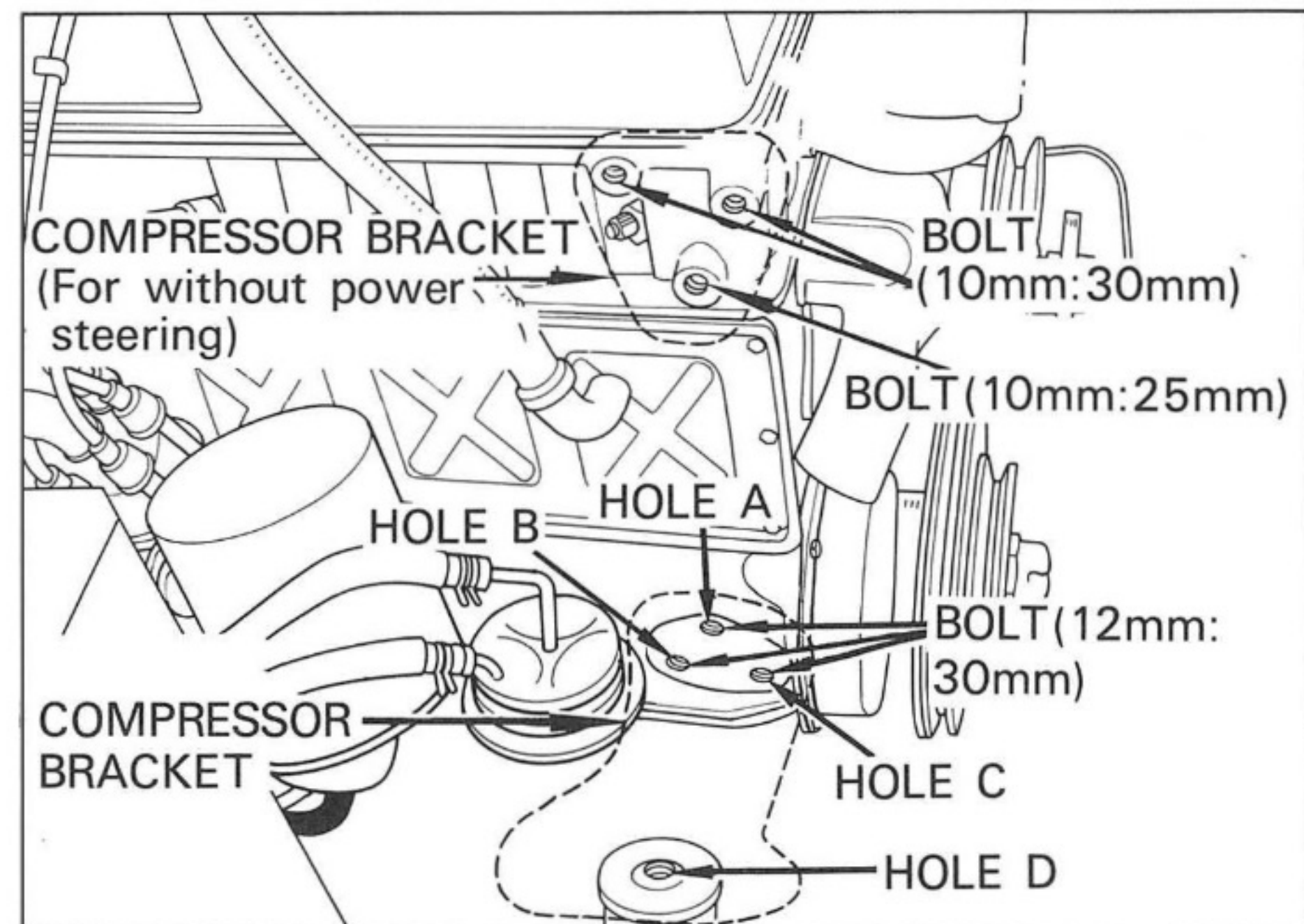

Fig. 15

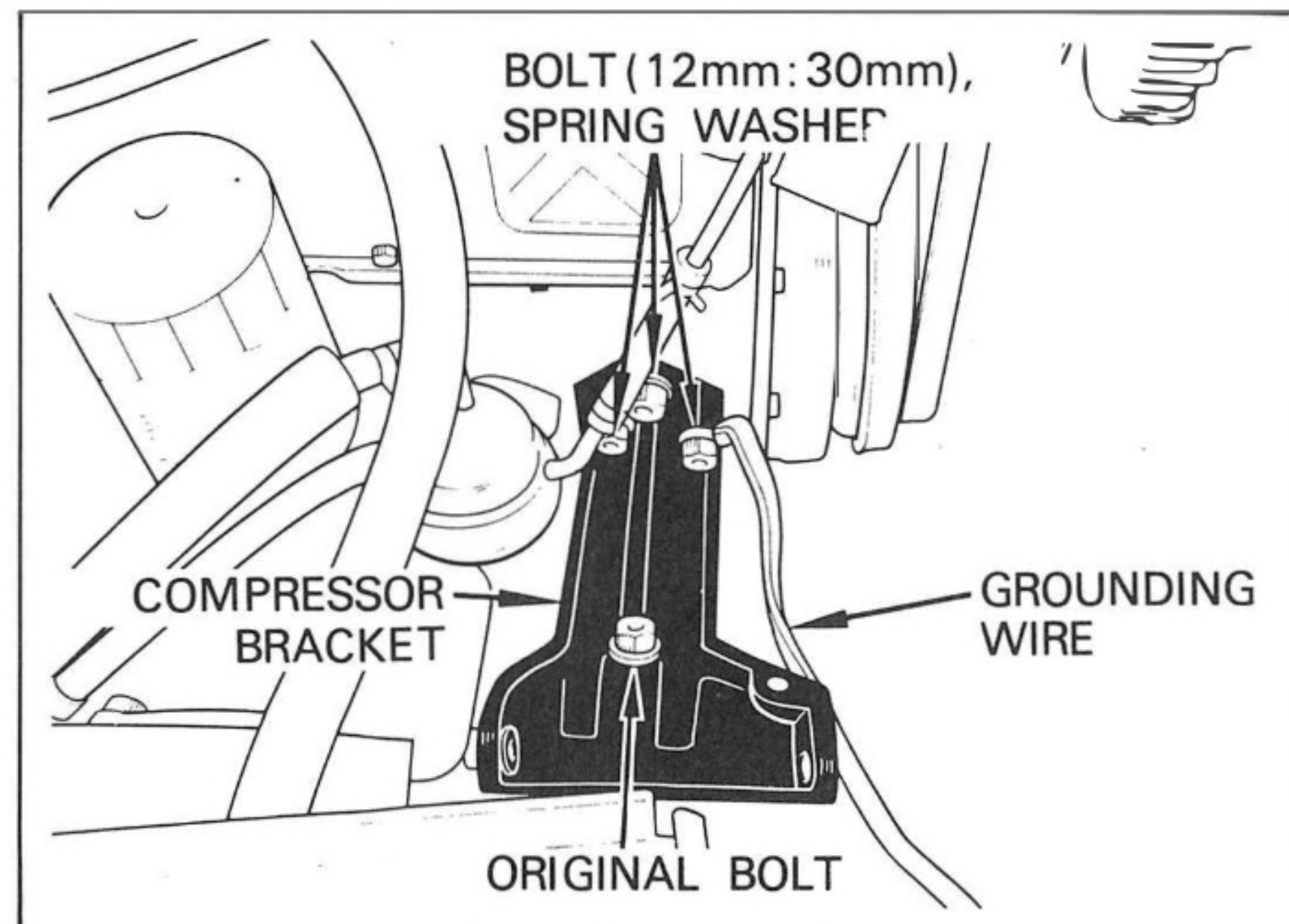

Fig. 16

2. INSTALLATION OF COMPRESSOR UPPER BRACKET

2-1 On Vehicle without Power Steering

- A) Install the compressor upper bracket and the original engine hanger to the engine using three threaded holes. See Fig. 16 & Fig. 17.

TORQUE :

4.0 – 5.5 kg-m (30 – 40 ft-lb)

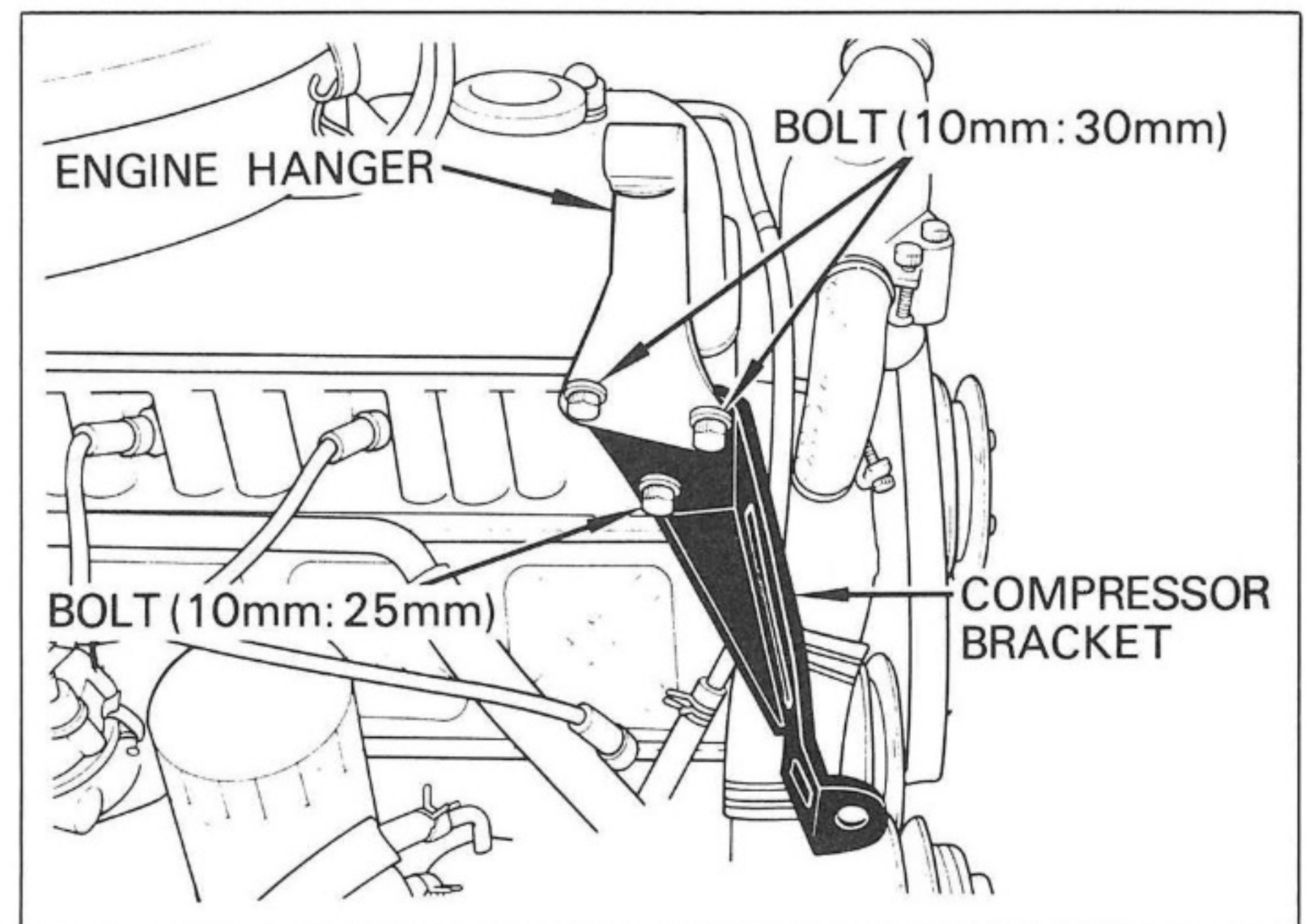

Fig. 17

2-2 On Vehicle with Power Steering

- A) Install the compressor upper bracket to the power steering pump bracket using two threaded holes.

TORQUE :

2.5 – 3.0 kg-m (1.8 – 2.2 ft-lb)

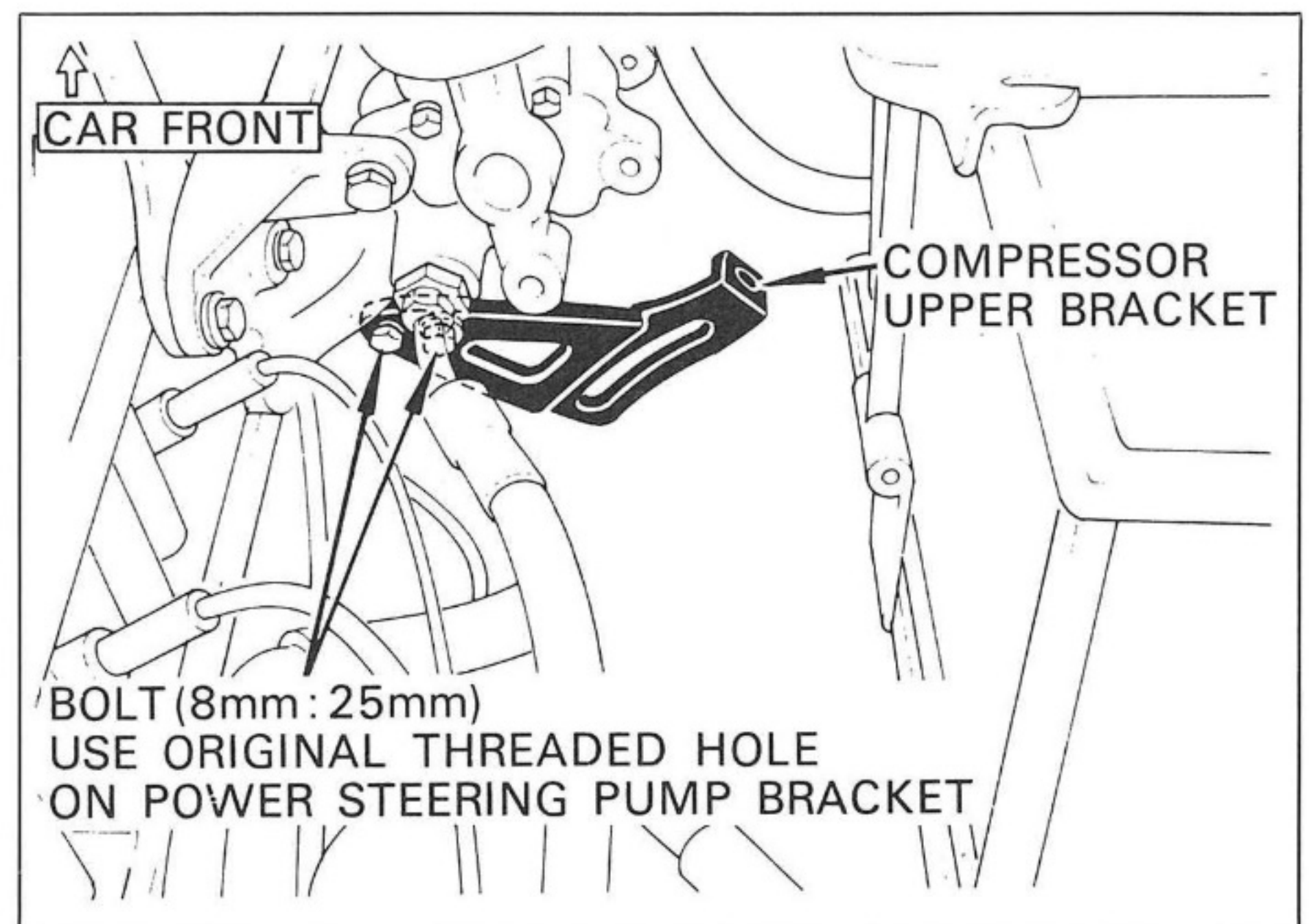

Fig. 18

3. INSTALLATION OF CRANKSHAFT PULLEY

- A) Clean up to the crankshaft surface and the mating surface-to-crankshaft of the crankshaft pulley provided in the kit.
- B) Install the crankshaft pulley onto the crankshaft using the new lock washer and the original bolt and bend the lock tab.

TORQUE :

16.0 – 20.0 kg-m (115 – 145 ft-lb)

Note: When installing the crankshaft pulley, be careful not to damage the crankshaft seal and pulley.

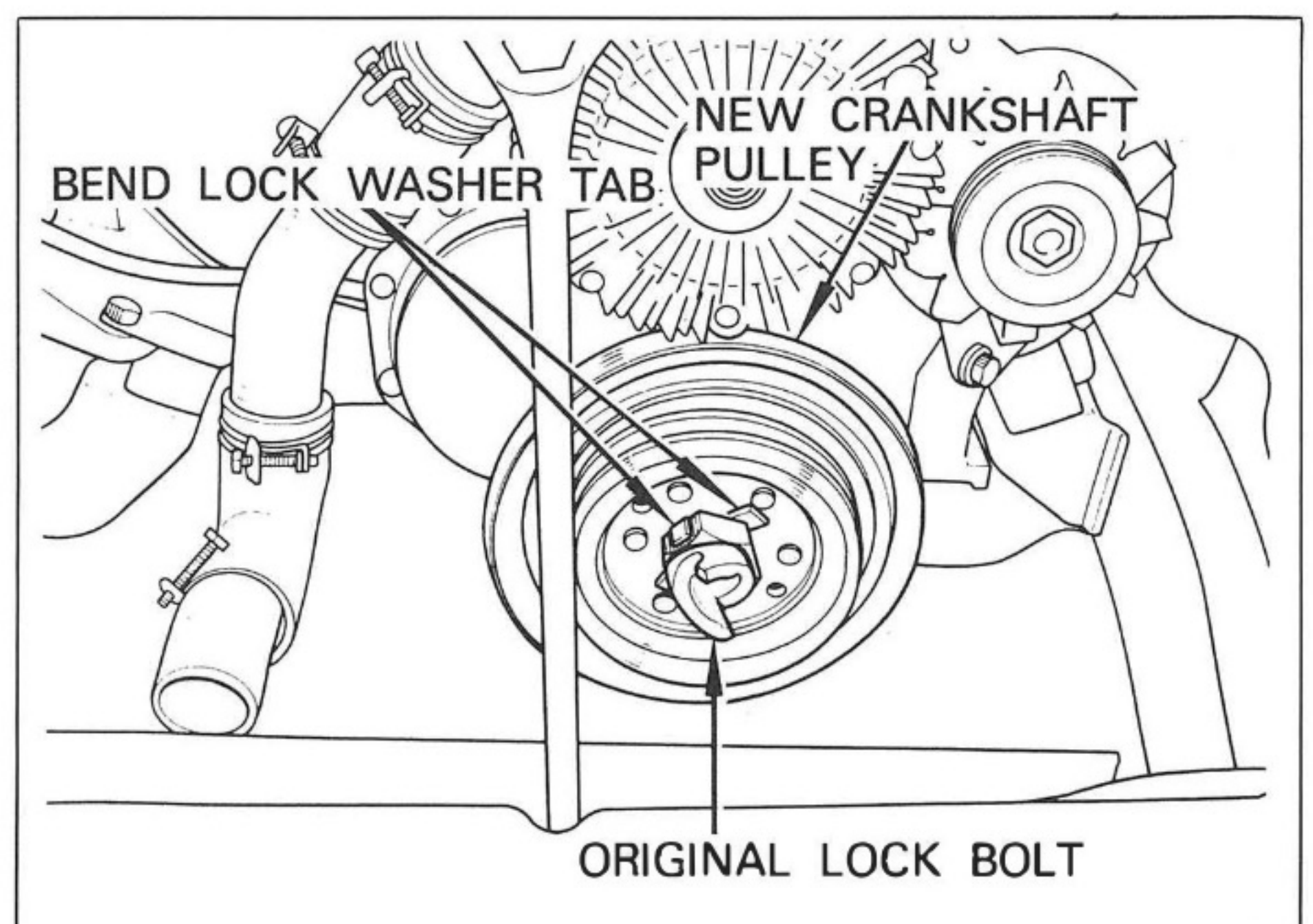

Fig. 19

4. INSTALLATION OF RADIATOR PIPE AND RADIATOR HOSES

A) Connect the two new radiator hoses to the new radiator pipe provided in the kit, using original hose band.

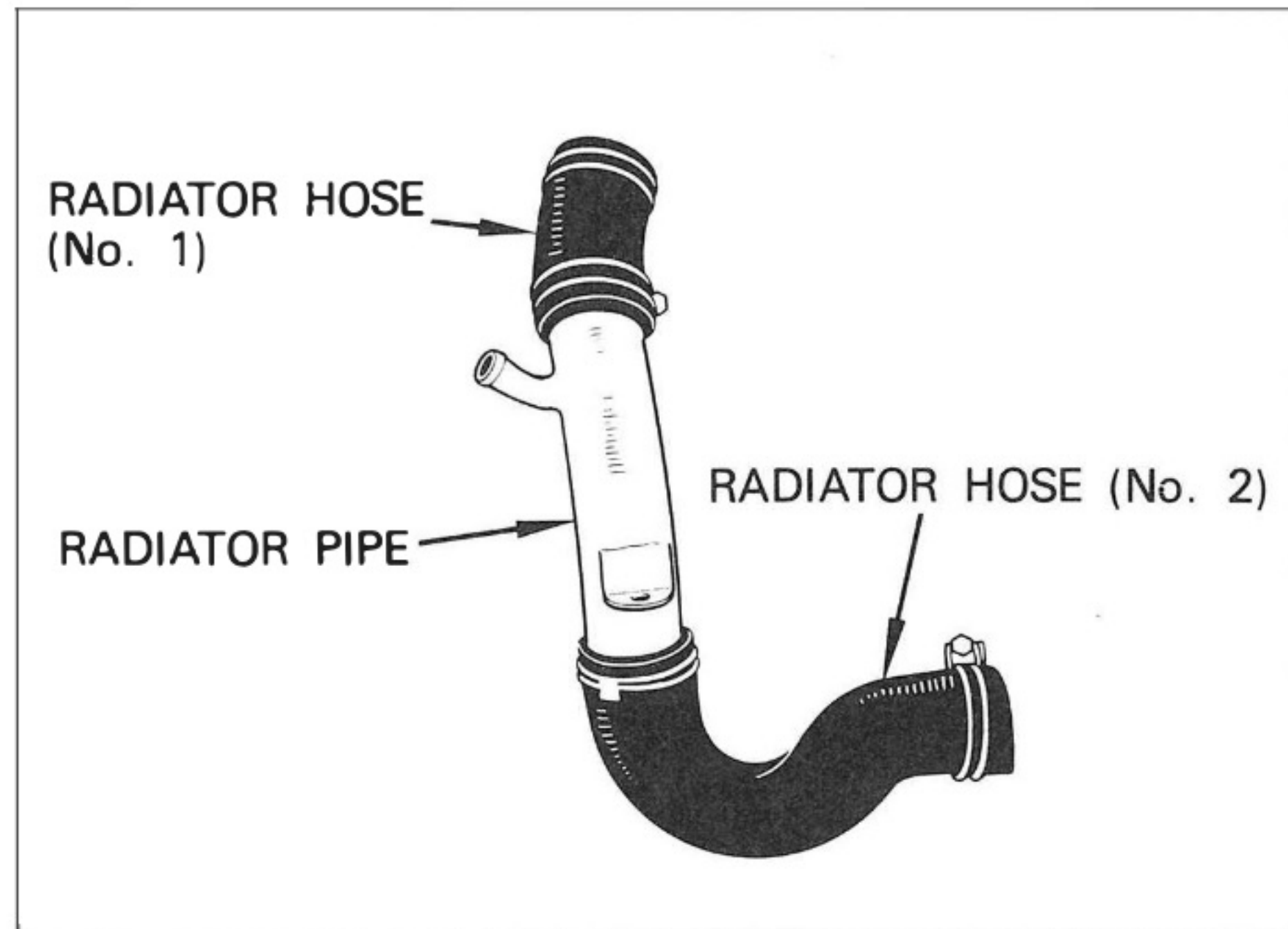

Fig. 20

B) Connect the radiator hose w/pipe to the engine and fasten it to the compressor bracket.

Note: Locate the hose bands as shown in Fig. 21 to avoid interference with compressor drive belt.

C) Reinstall the heater hose to the radiator pipe.

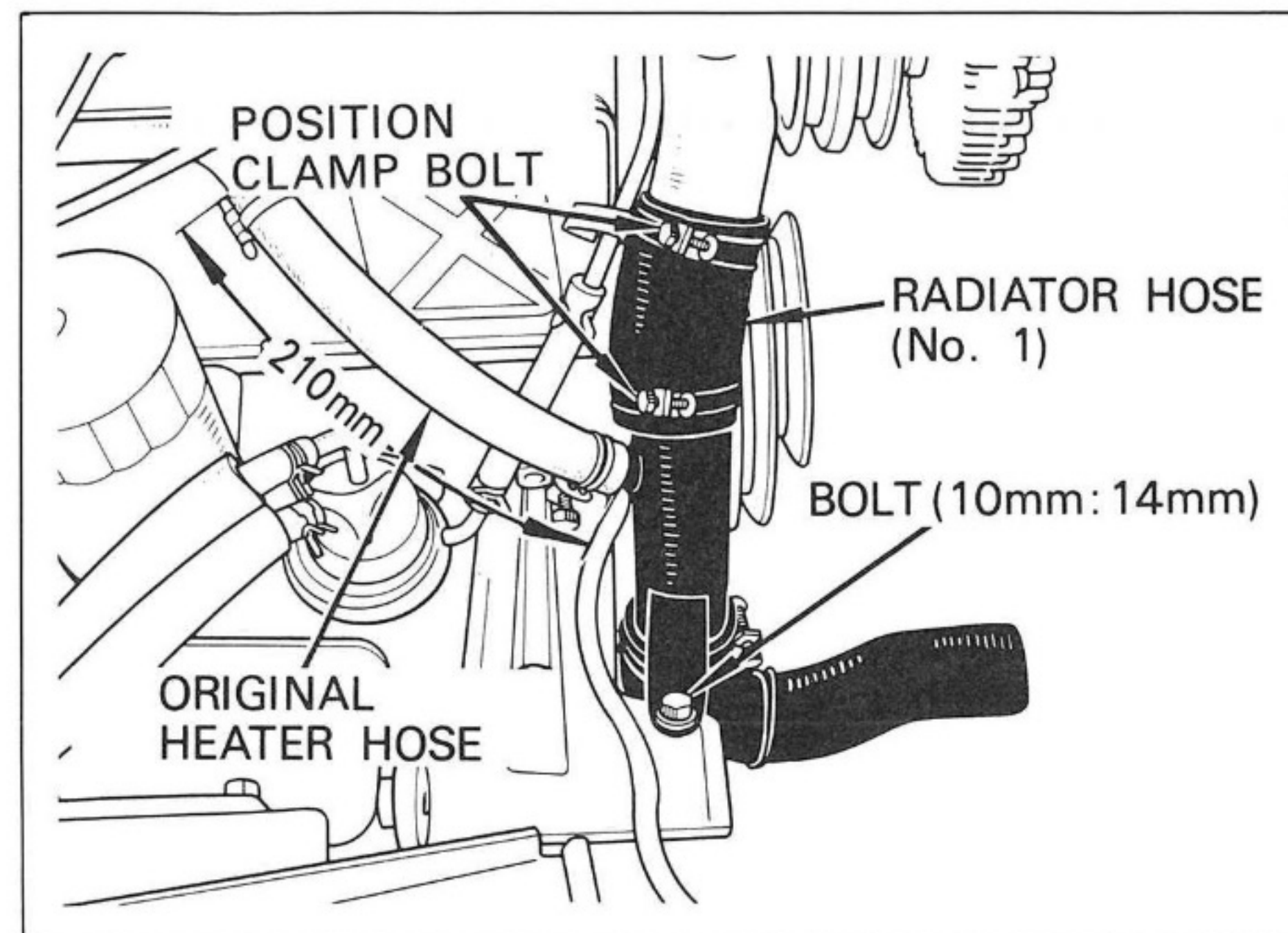

Fig. 21

D) Cut the original heater hose to 210mm long to avoid interference with compressor.

5. INSTALLATION OF IDLE PULLEY

A) Assemble the idle pulley to the idle pulley bracket.

B) Install the idle pulley to the compressor bracket as shown in Fig. 22.

TORQUE :

4.0 – 5.5 kg-m (30 – 40 ft-lb)

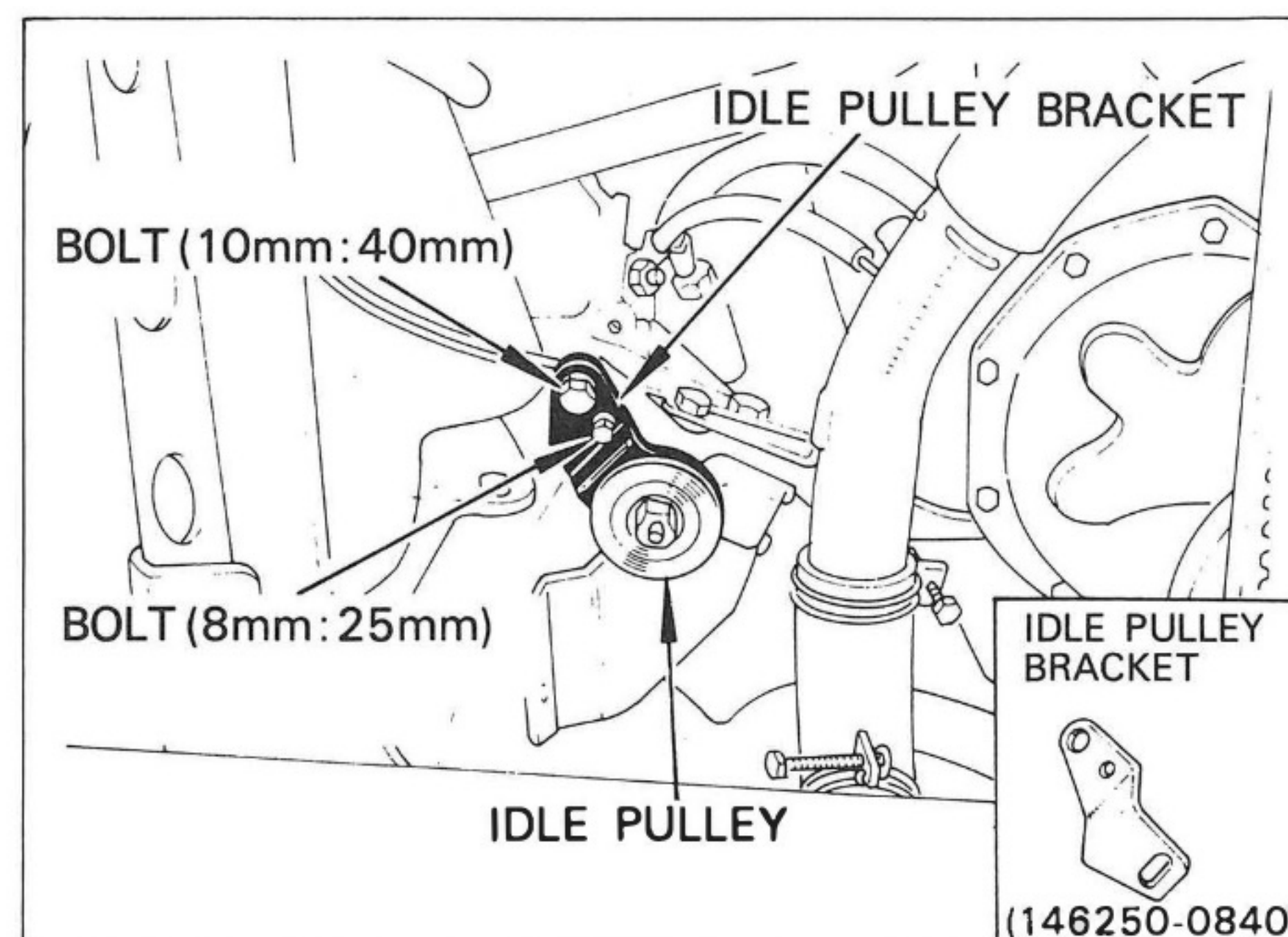

Fig. 22

6. INSTALLATION OF COMPRESSOR

- A) Install the compressor to the compressor bracket using three bolts (head mark 8), adjust bolt and nuts.

Note: Do not tighten bolts.

- B) Install the wire clamp the compressor boss as shown in Fig. 23.

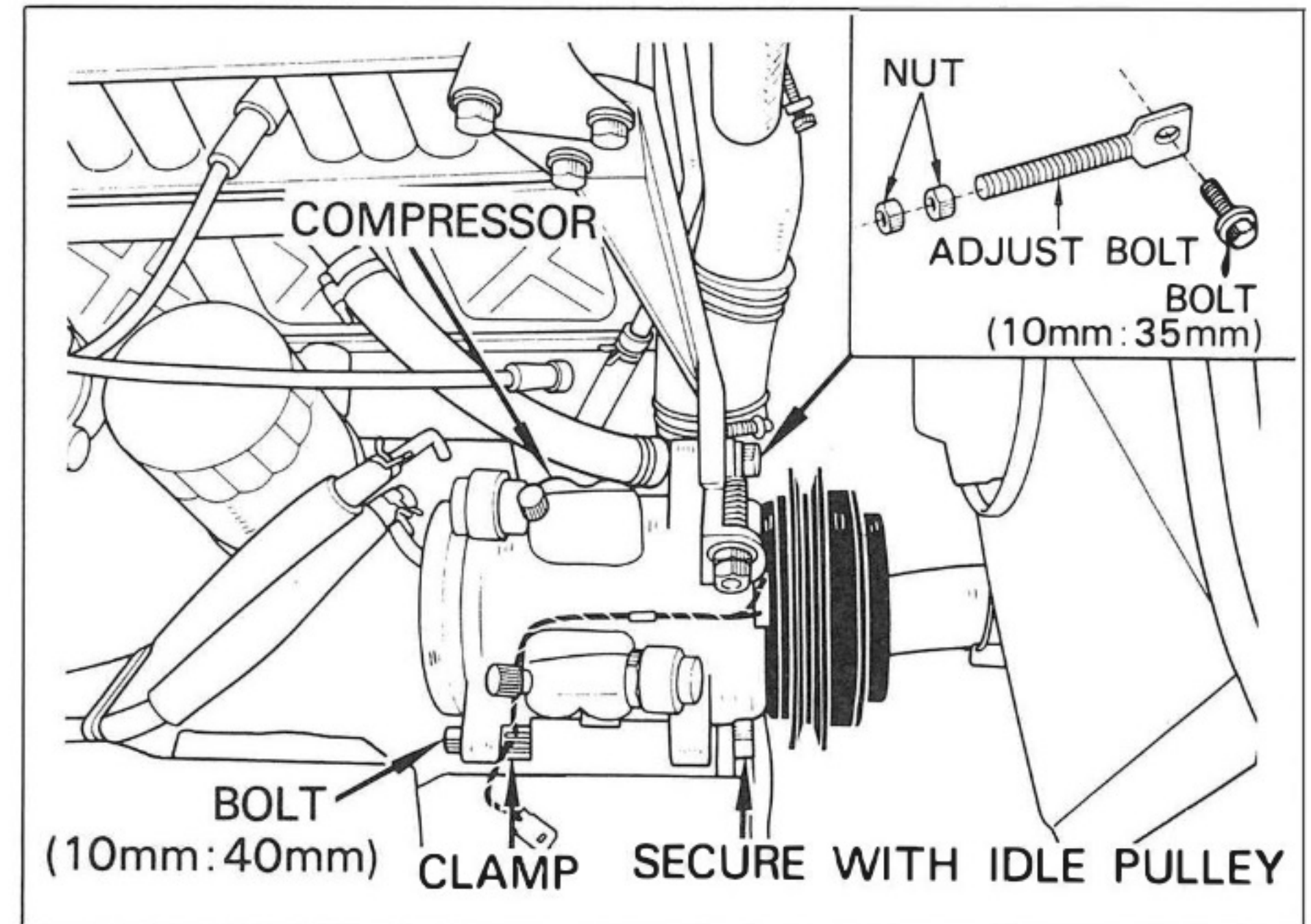

Fig. 23

7. INSTALLATION AND ADJUSTMENT OF DRIVE BELT

- A) Install the compressor drive belt onto the magnetic clutch and crankshaft pulley.
- B) Adjust the belt tension by screwing the nut of adjust bolt.

- C) Tighten the compressor belts.

TORQUE :

4.0 – 5.5 kg-m (30 – 5.5 ft-lb)

- D) Reinstall the fan belt and adjust its tension by the alternator.

- E) On vehicle with power steering, reinstall the belt on the power steering pulley and adjust its tension by the power steering pump.
Deviating distance when pushed with a 10kg force.

Fan Belt 7 – 10 mm

Compressor Drive Belt 15 – 18 mm

Power Steering Belt 11 – 14 mm

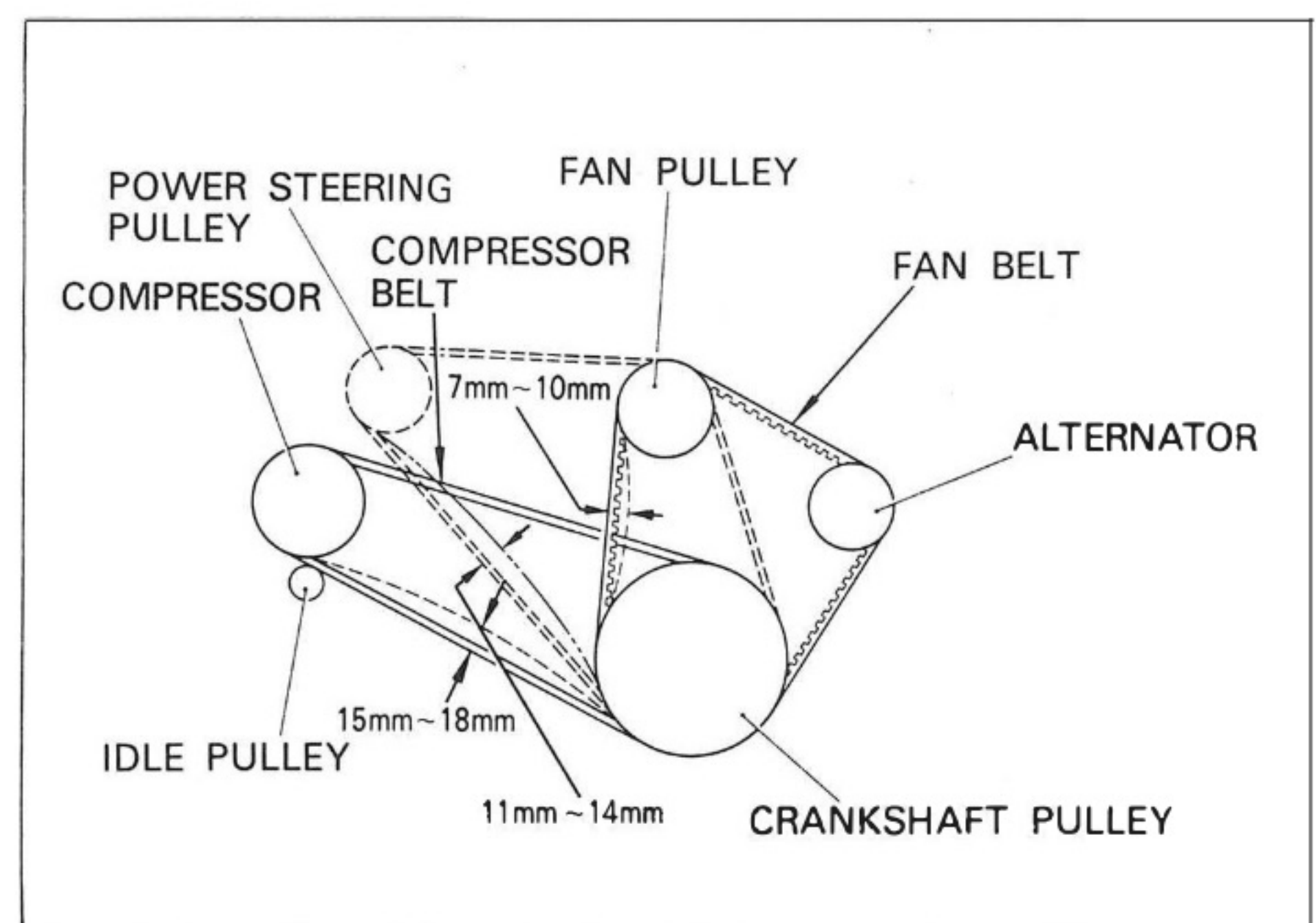

Fig. 24

8. RADIATOR AND FAN SHROUD

- A) Put the packing under the radiator.
- B) Reinstall the radiator and fan shroud. See Fig. 25.

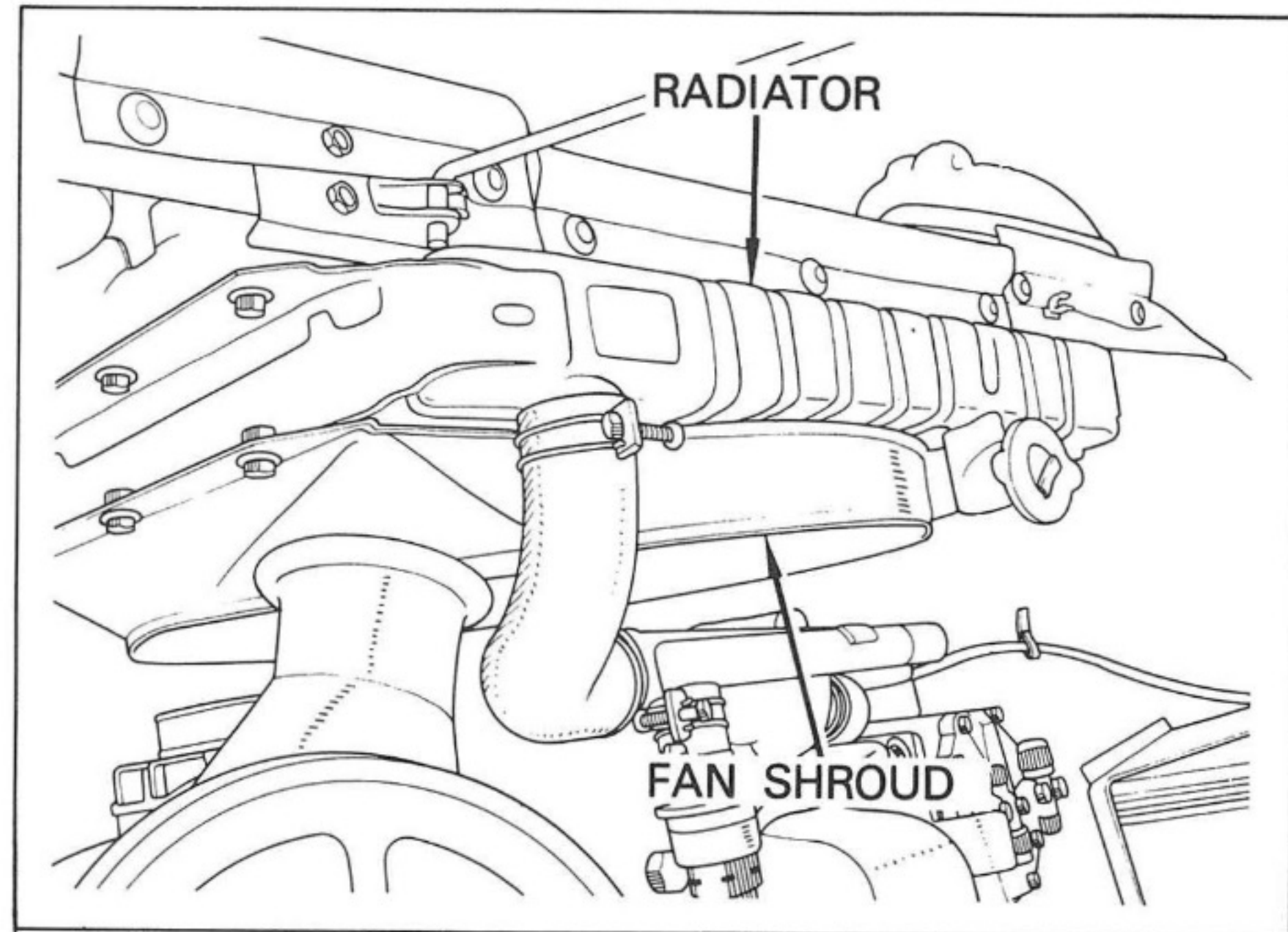

Fig. 25

9. CONDENSER

- A) Install the condenser using four bolts in the kit on the radiator side baffle where threaded holes are provided. See Fig. 26.

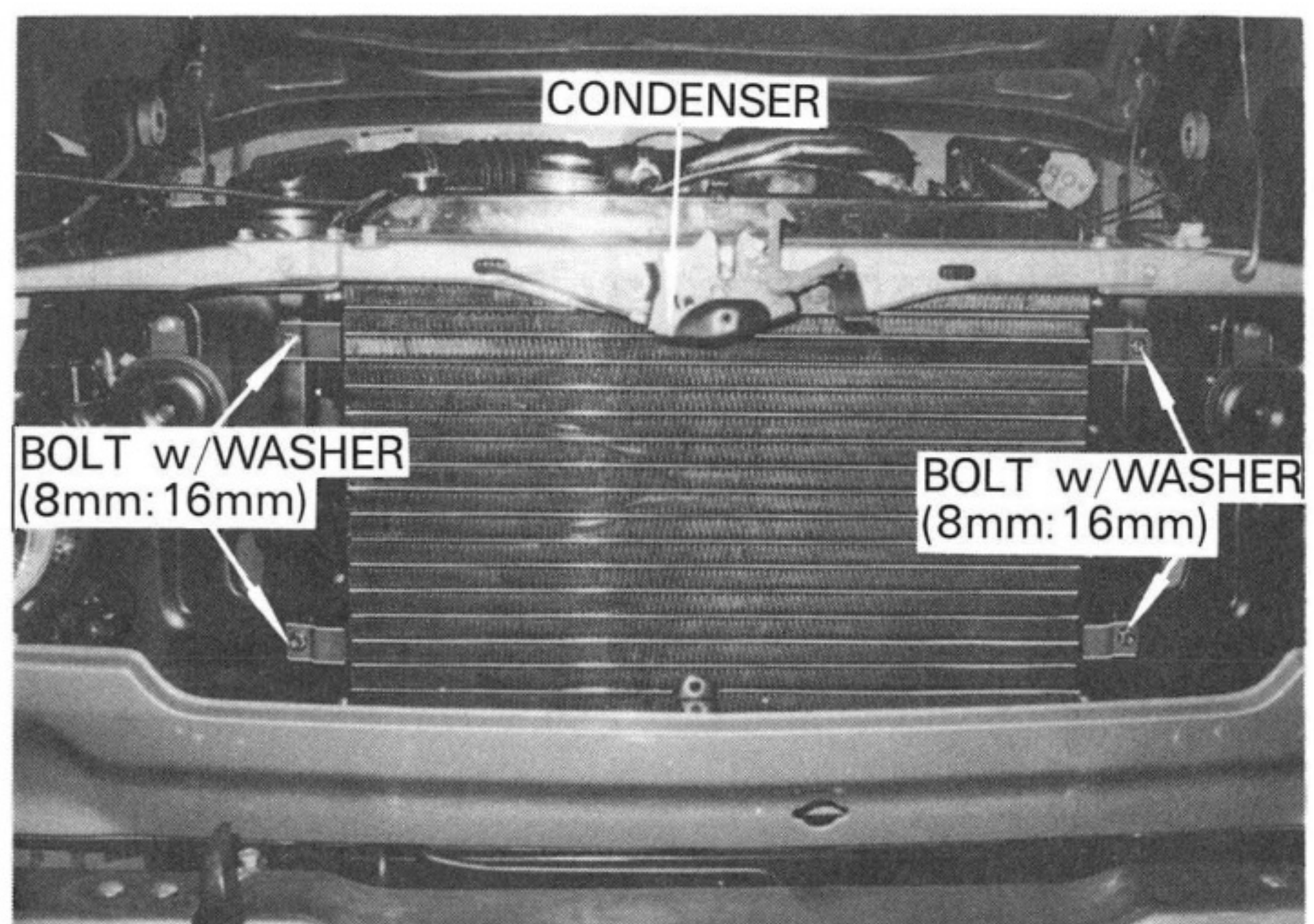

Fig. 26

10. RECEIVER HOLDER

- A) Install the receiver holder onto the side panel using original threaded holes and new bolts.

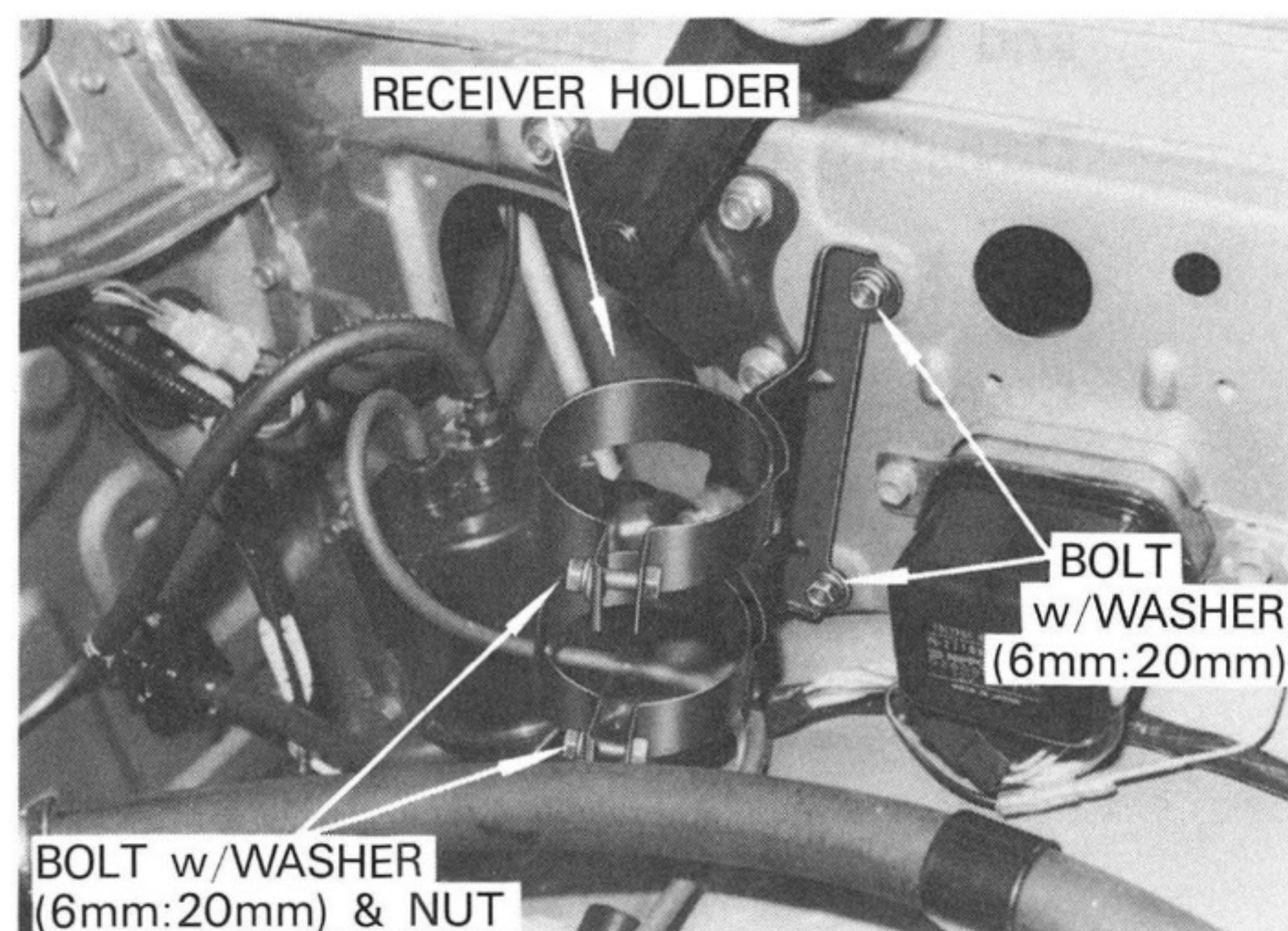

Fig. 27

II-3 PIPING

- * Before making any hose and tube connections, apply a few drops of refrigeration oil to the seat of flare nut, plus the flare and threads.
- * When tightening and loosening fittings, use two spanners.

Tighten coupling nuts according to specified torque.

Standard Torque for O-ring.

Size of Tube	Fixing Torque
for 0.38 inch tube	1.2 – 1.5 kg-m (12 – 15 N-m)
for 0.50 inch tube	2.0 – 2.5 kg-m (20 – 25 N-m)
for 0.63 inch tube	3.0 – 3.5 kg-m (30 – 35 N-m)

1. LIQUID LINE TUBE AND HOSE

- A) Connect the liquid line tube to the condenser outlet fitting.
- B) Fasten the liquid line tube using a tube clamps as shown in Fig. 28.
- C) Install the receiver into the receiver holder.

Note: 1) Do not remove the blind plugs from inlet and outlet fittings of receiver until the tubes are already for connection.

2) When installing the receiver ensure that the inlet fitting "IN" is facing towards the front.

- D) Drille 7 mm diameter hole on the tire apron according to the dimension in Fig. 29.
- E) Provide the liquid line hose with a rubber bushing.
- F) Connect the liquid line hose between the liquid line tube and receiver inlet fitting marked "IN".
- G) Position the rubber bushing on the wire harness connected to alternator.

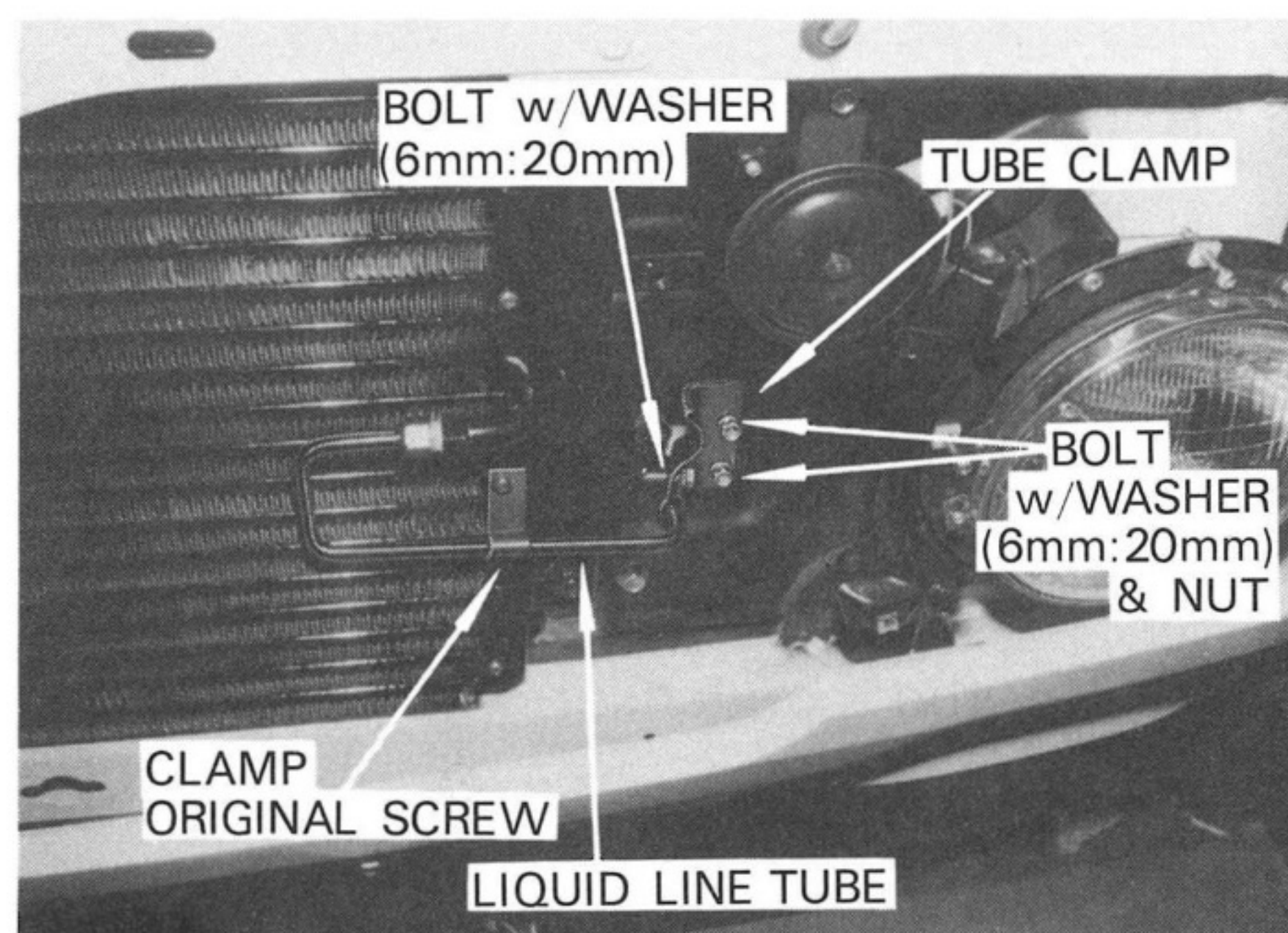

Fig. 28

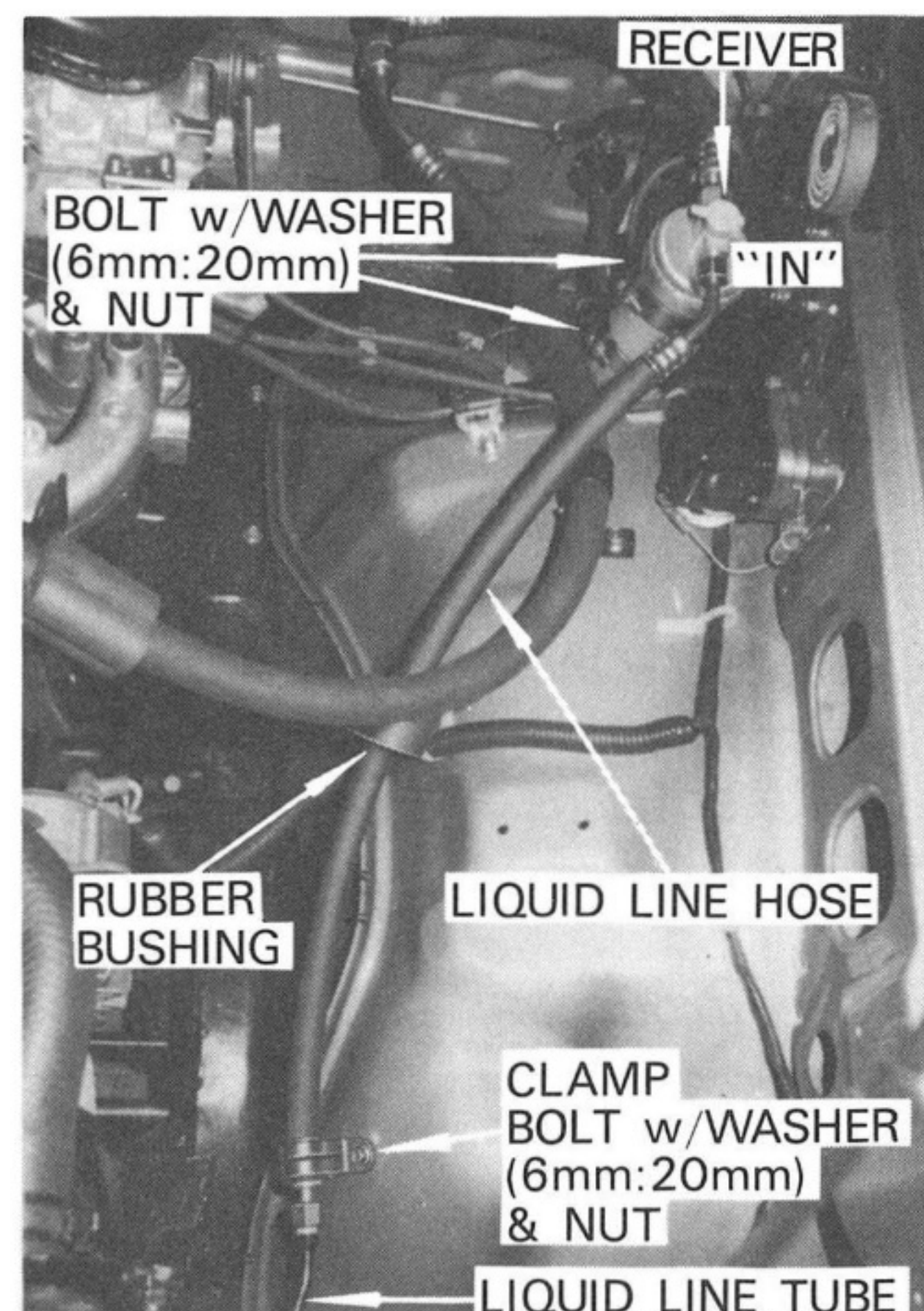

Fig. 29

H) Fasten the liquid line hose using a hose clamp and a bolt.

I) Connect the liquid line hose to the receiver outlet and the cooling unit inlet fitting.

See Fig. 30.

CAUTION

Liquid line hose should be routed to avoid interference with surrounding parts.

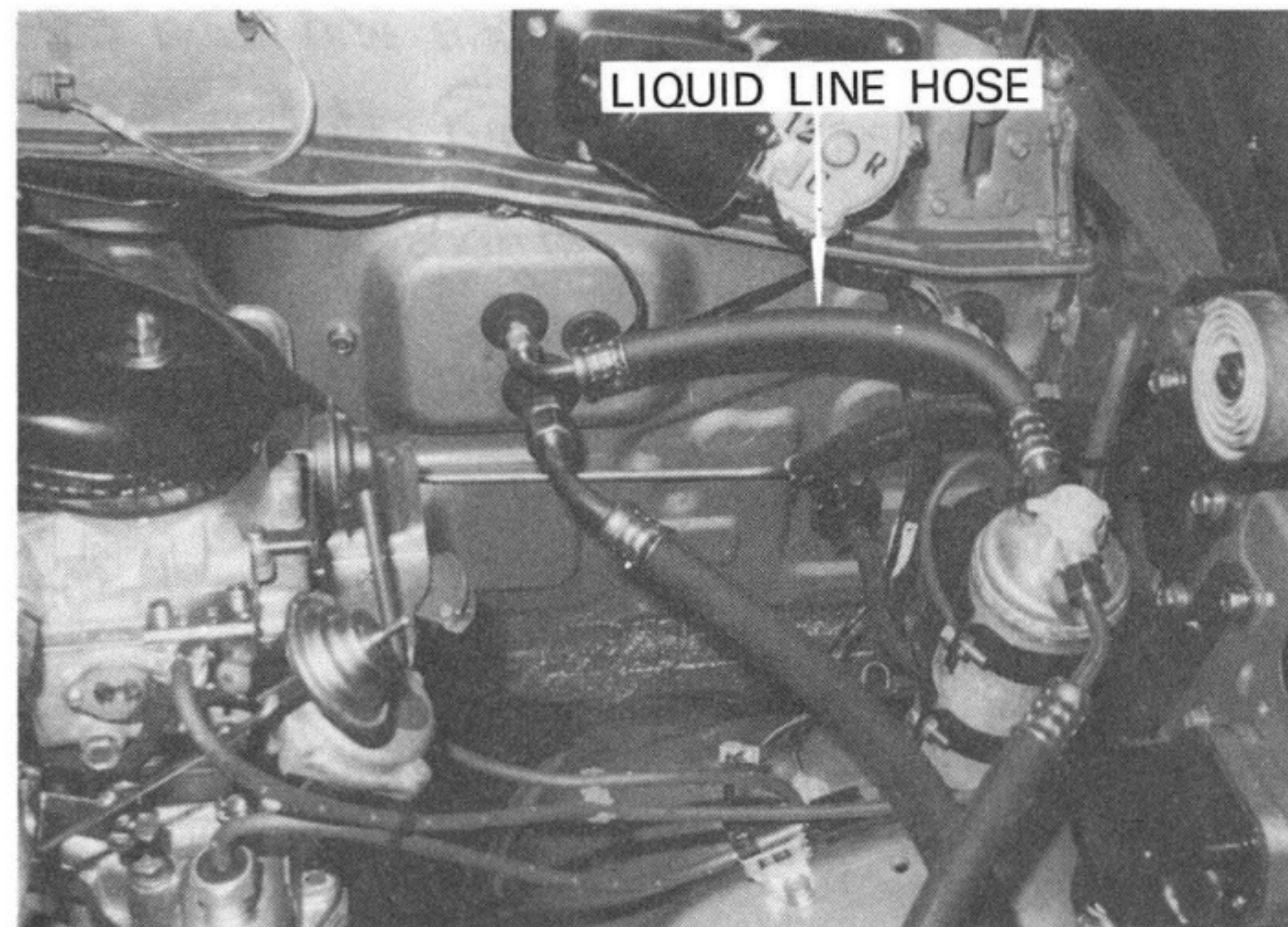

Fig. 30

2. DISCHARGE FLEXIBLE HOSE

A) Install the hose clamp to the discharge flexible hose using a bolt as shown in Fig. 31 (Upper Left Figure).

B) Connect the discharge flexible hose to the condenser inlet and compressor discharge side fitting.

See Fig. 32.

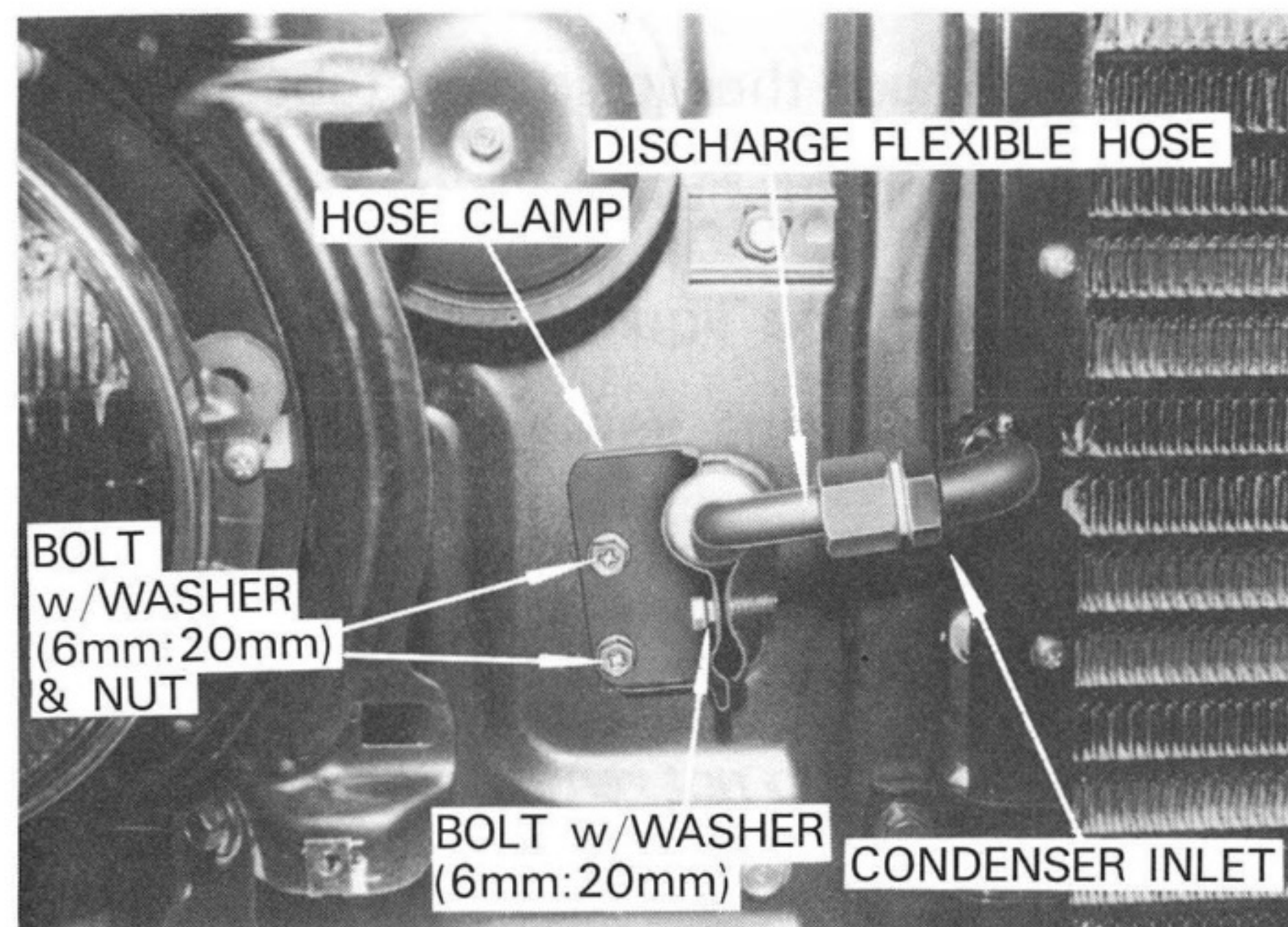

Fig. 31

C) Fasten the discharge flexible hose onto the panel using two bolts and nut as shown in Fig. 31.

CAUTION

Discharge flexible hose should be routed to avoid interference with surrounding parts.

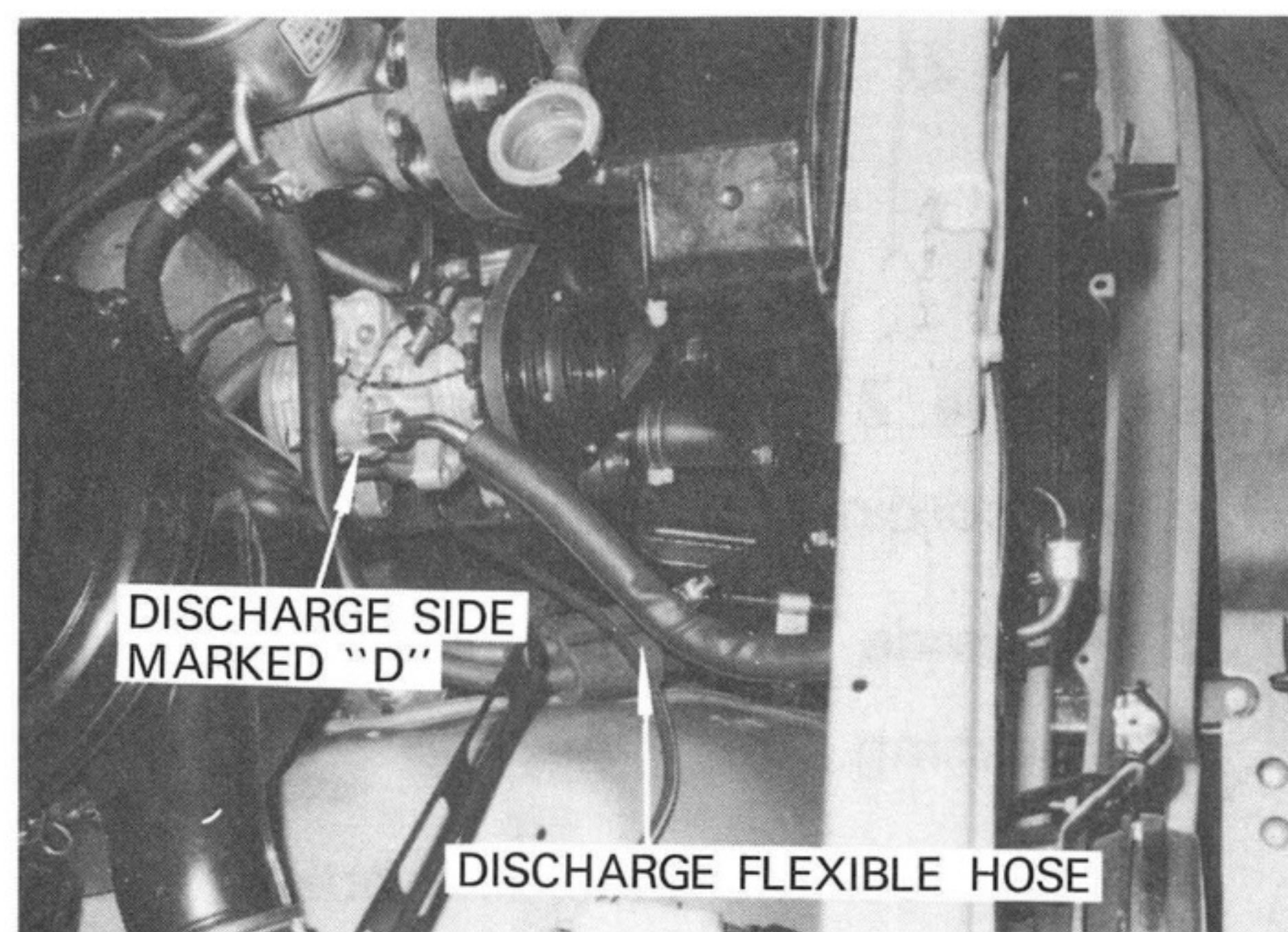

Fig. 32

3. SUCTION FLEXIBLE HOSE

- A) Route the suction flexible hose as shown in Fig. 33.
- B) Connect the L-shaped fitting of the suction flexible hose to the compressor suction side.
- C) Connect the other fitting of the suction flexible hose to the cooling unit outlet fitting.

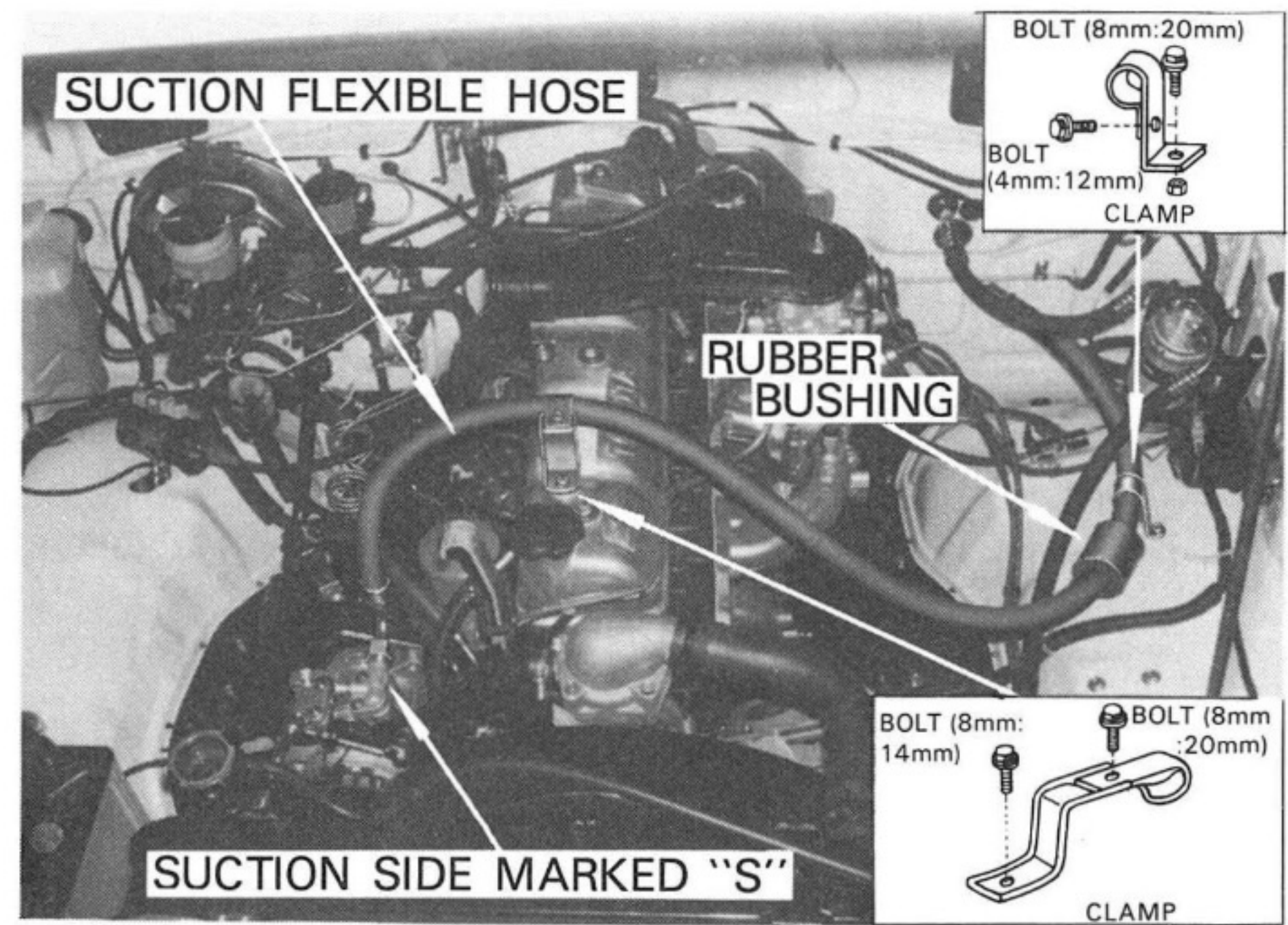

Fig. 33

- D) Fasten the suction flexible hose on the engine cylinder head using L-shaped bracket and a clamp. See Fig. 34.
- E) Fasten the suction flexible hose on the left tire apron using a clamp and bolt.

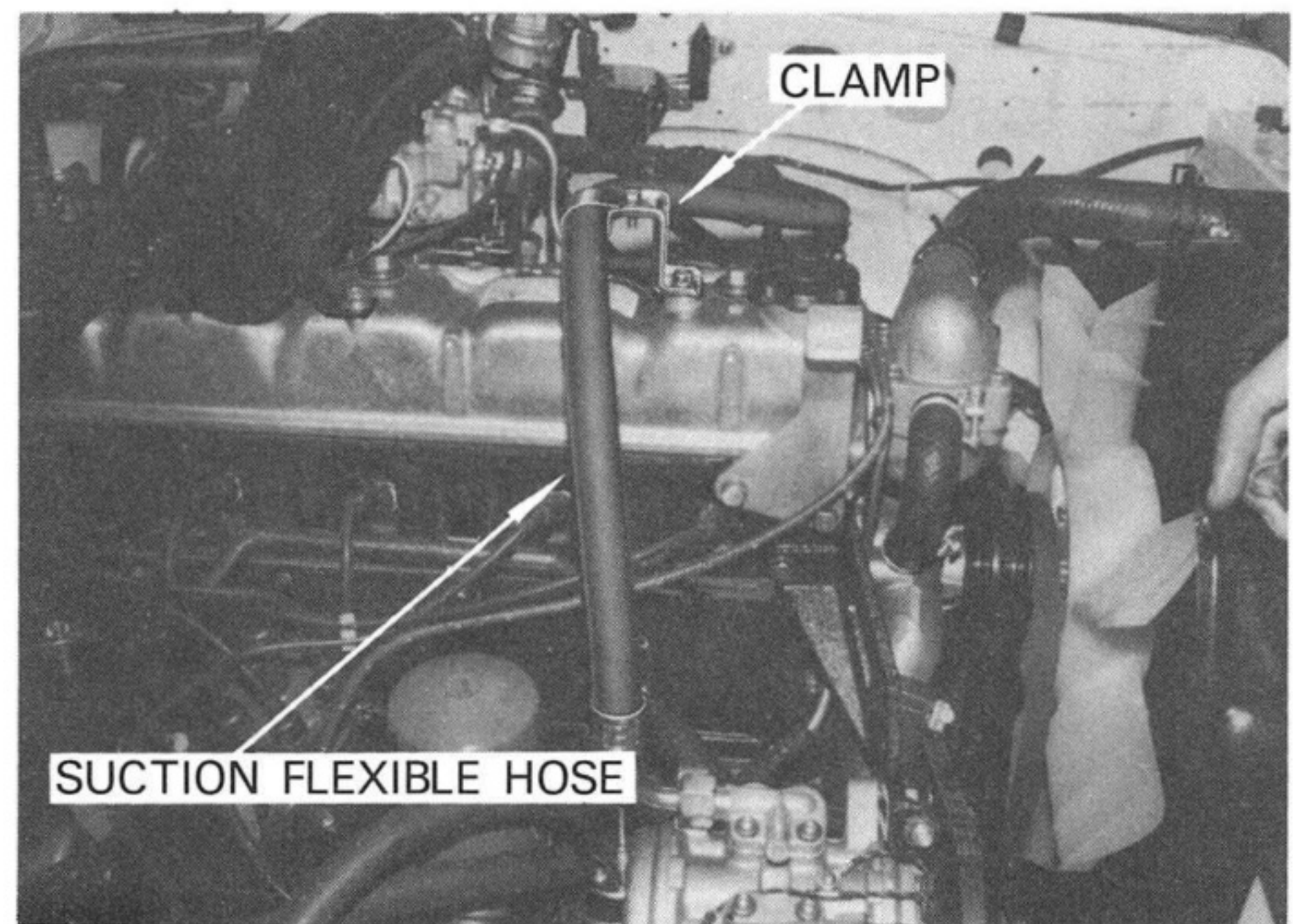

Fig. 34

II-4 ENGINE IDLING SPEED CONTROL DEVICE(Only For Australian Model)

1. ACTUATOR

- A) Temporarily remove the existing nut, washer and original lever from the throttle shaft.
- B) Install the lever of actuator onto the throttle shaft and reinstall the original lever, washer and nut. See Fig. 35.
- C) Fix the actuator on the flange of carburetor together with vacuum hose joint bracket using two screws. See Fig. 35.

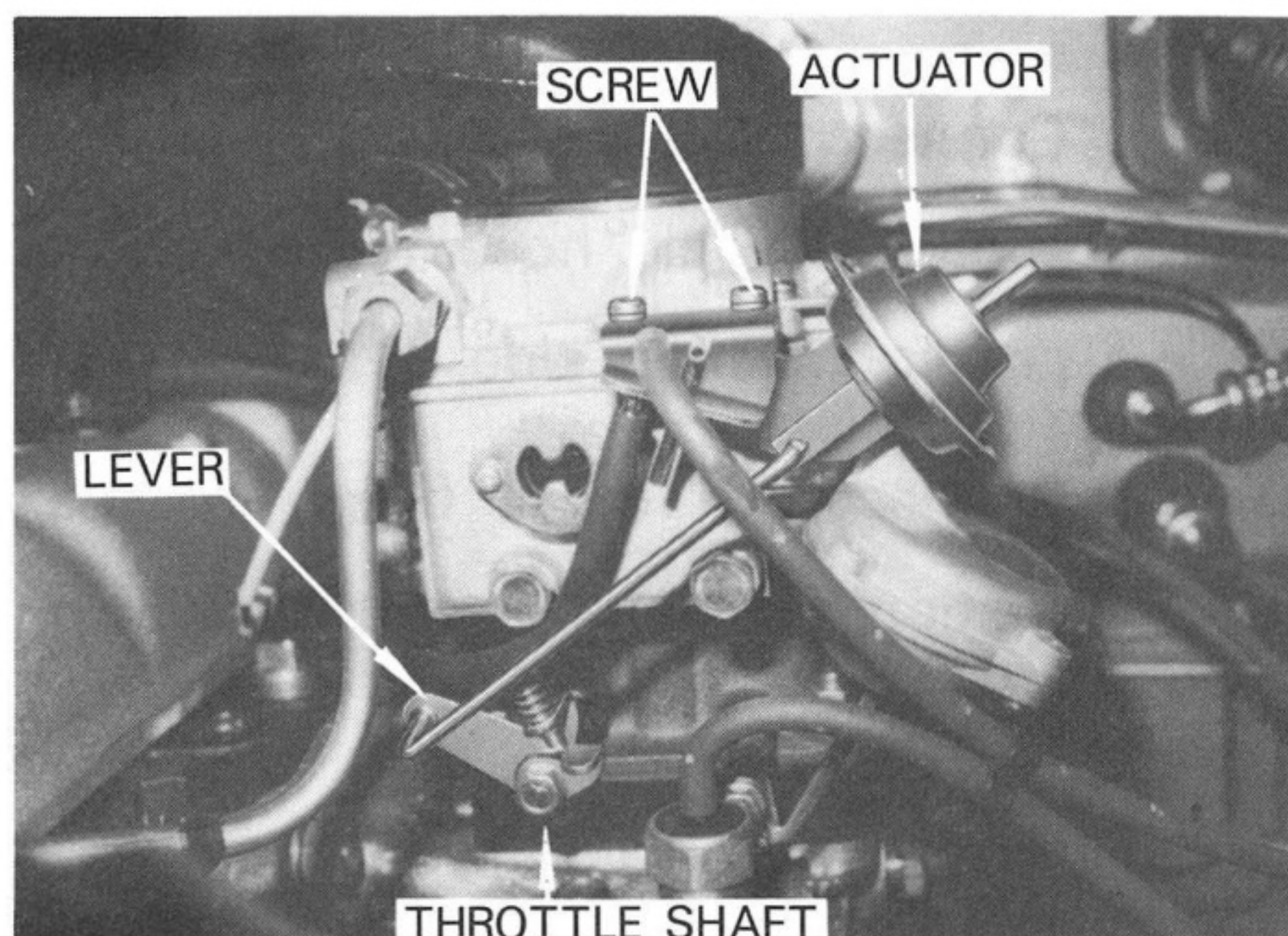

Fig. 35

2. V.S.V (Vacuum Switching Valve)

- A) Install the VSV on the side panel using original washer tank fixing bolt. See Fig. 36.

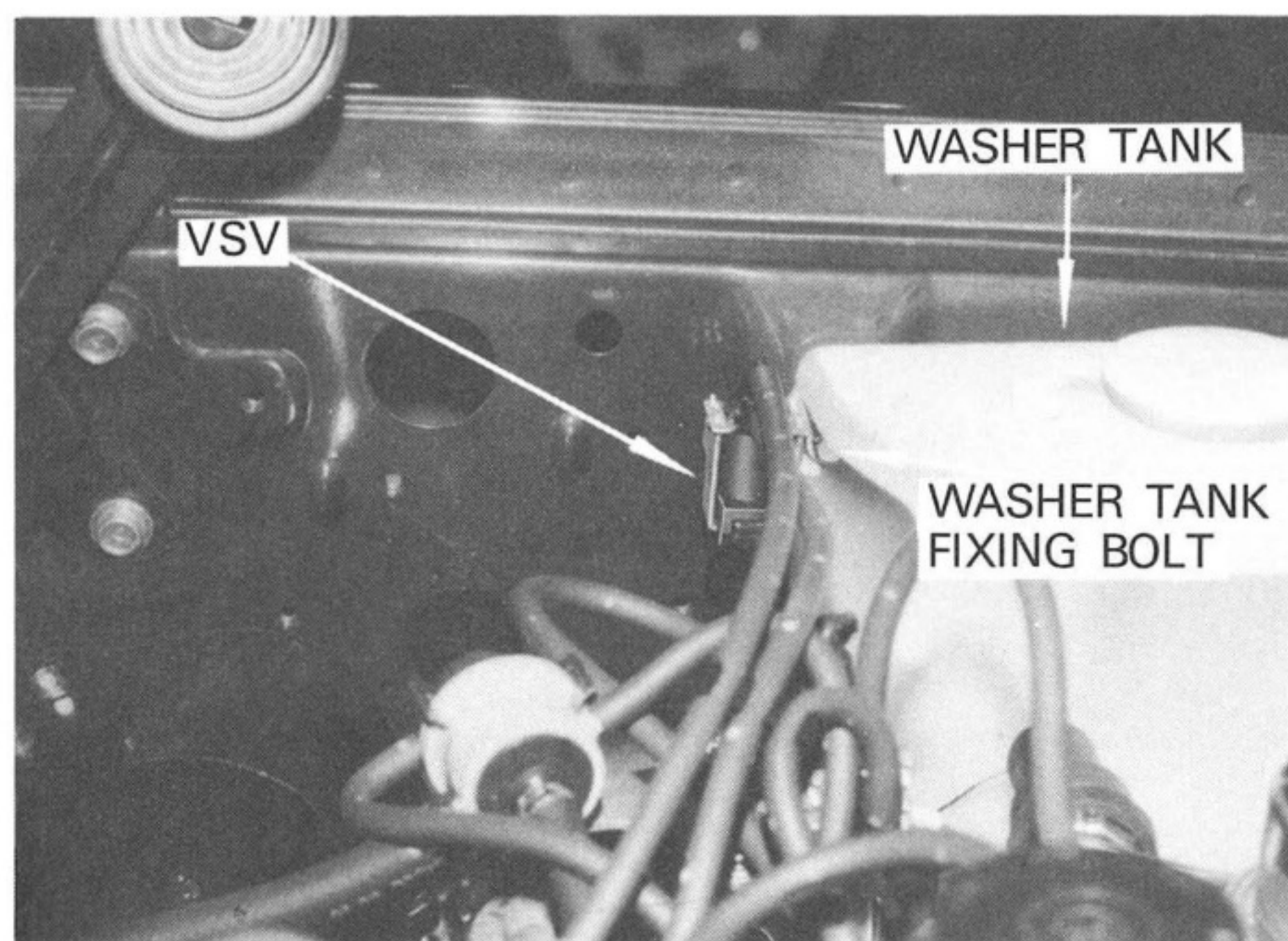

Fig. 36

3. VACUUM JOINT

- A) Replace the vacuum joint installed on the intake manifold with new one provided in the kit.

Note: *If the vehicle had no original vacuum joint, (after installing it) put the blind cap on the top of the new vacuum joint.*

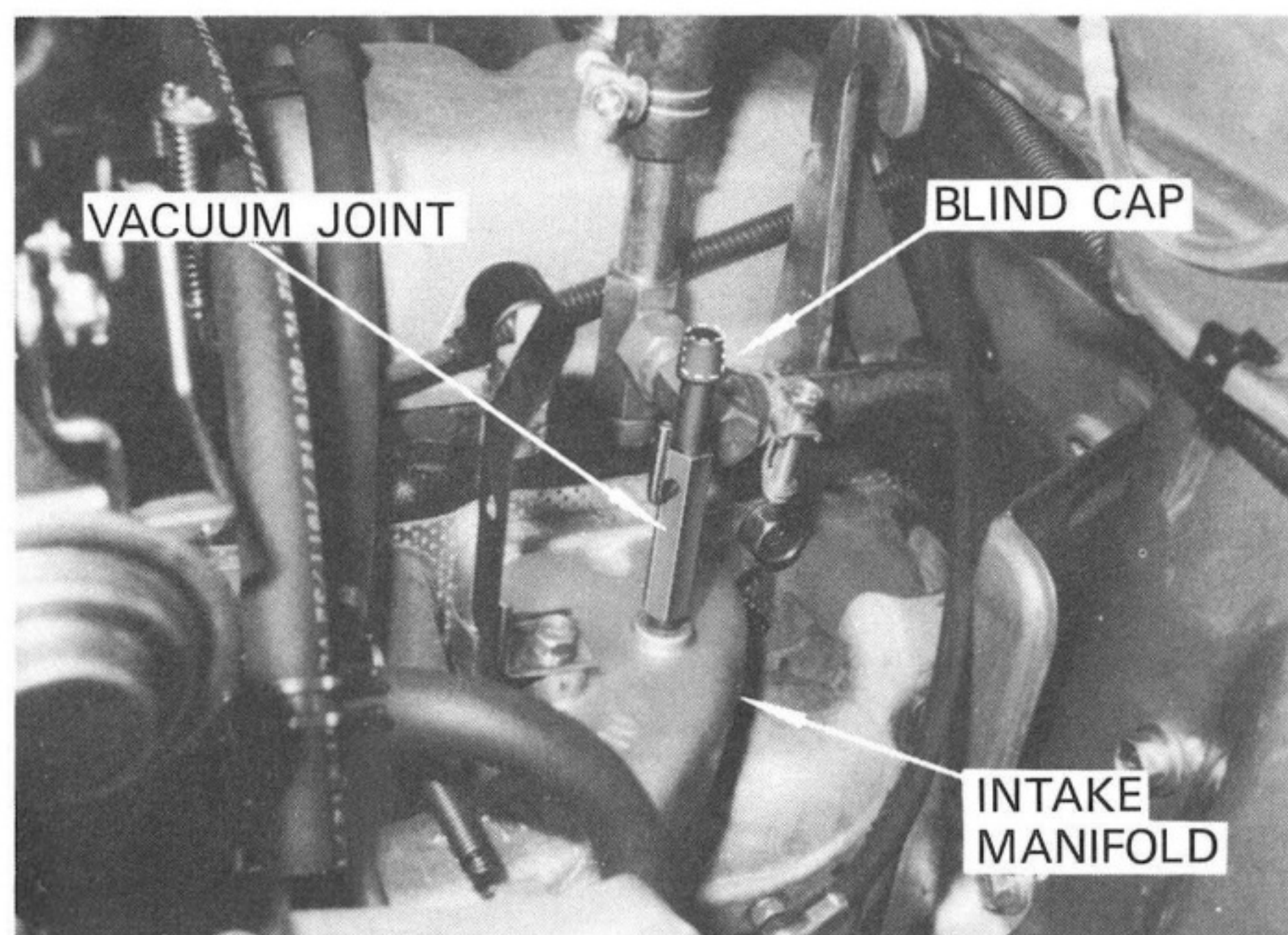

Fig. 37

4. VACUUM HOSE

- A) Connect the vacuum hose "✖" of VSV to the actuator.
- B) Connect the vacuum hose "O" of VSV to the vacuum joint.
- C) Fasten the vacuum hose using clamps as shown in Fig. 38.

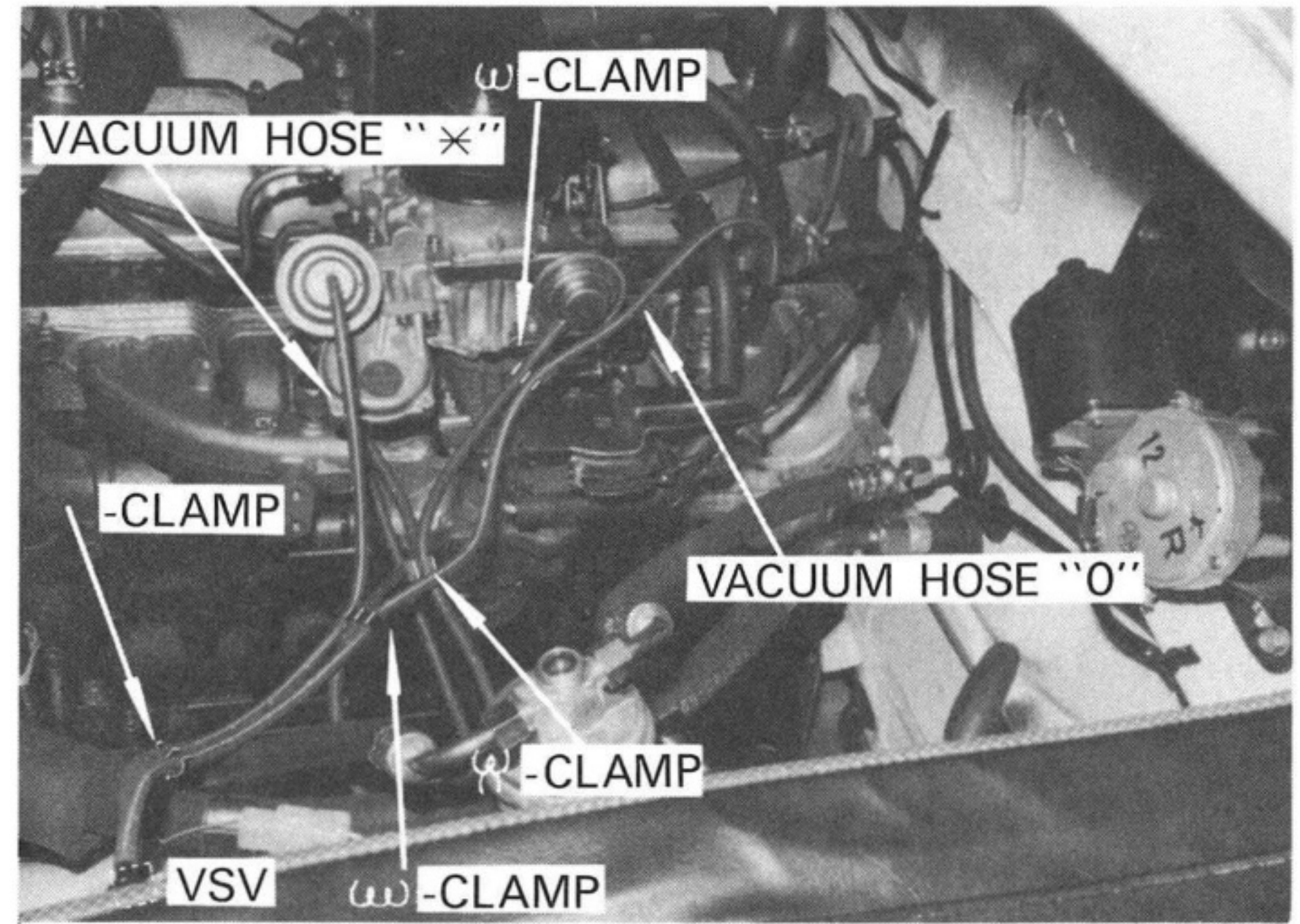

Fig. 38

II-5 WIRING

1. A/C WIRE HARNESS

- A) Route the A/C wire harness along the chassis as show in Fig. 39.
- B) Connect the 1-pole and 2-pole connector of A/C wire harness to magnetic clutch and VSV.
- C) Fasten the wire harness using clamps provided in a kit and original clamps. See Fig. 39.

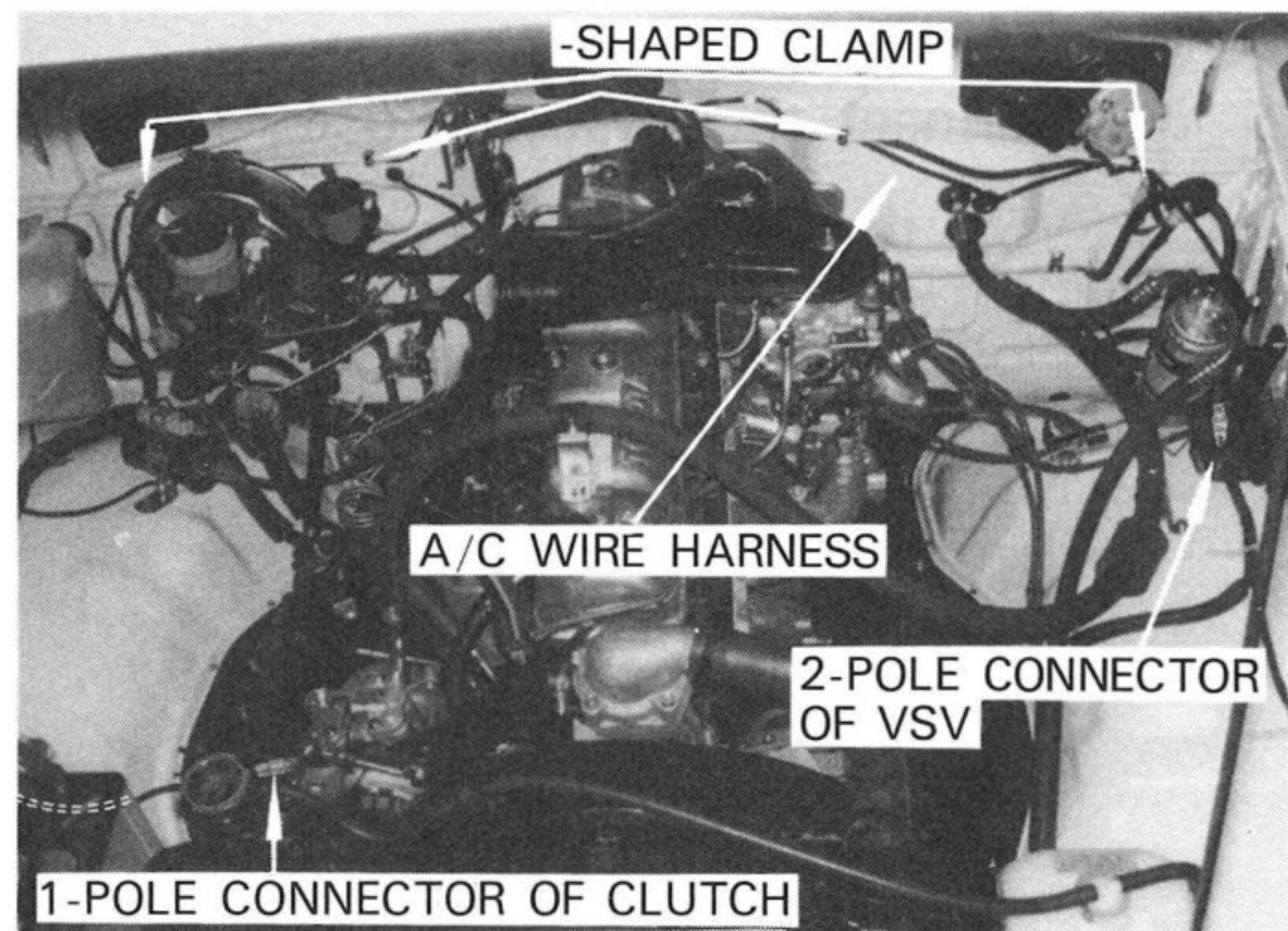
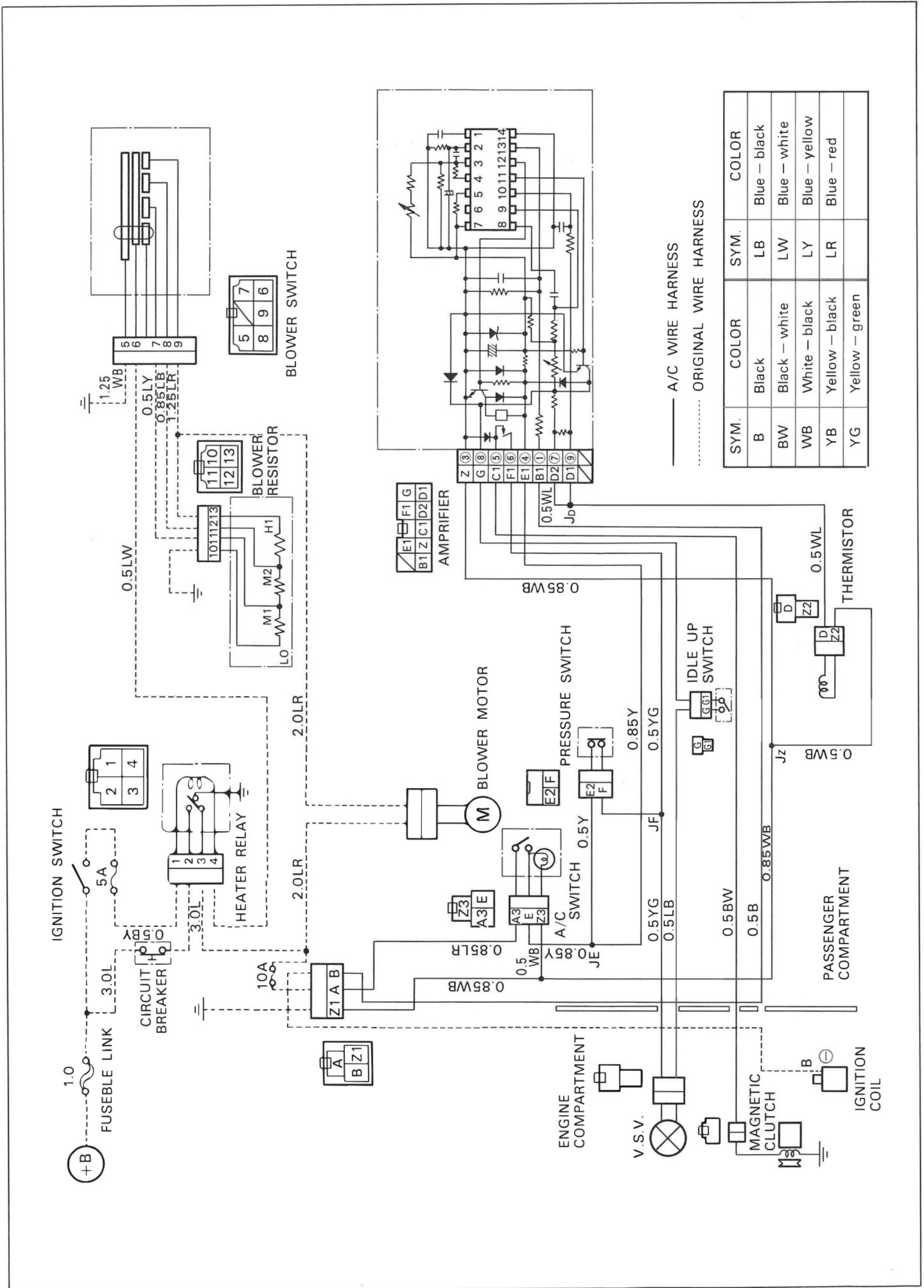

Fig. 39

CAUTION

1. *Connection of terminals or connectors should be done surely.*
2. *If disconnect or moving original harness while replacing, it should be returned to proper position.*
3. *Be careful not to pinch original and air conditioner wire harnesses during installation.*
4. *Be sure that the wire harness does not contact a sharp corner or edge.*

III WIRING DIAGRAM



— A/C WIRE HARNESS
 ORIGINAL WIRE HARNESS

SYM.	COLOR	SYM.	COLOR
B	Black	LB	Blue — black
BW	Black — white	LW	Blue — white
WB	White — black	LY	Blue — yellow
YB	Yellow — black	LR	Blue — red
YG	Yellow — green		

IV. FINISH

(Refer to "FINISH" described on following pages.)

- A) After finishing installation completely, reinstall, the parts which are temporarily removed.
- B) Make thorough inspection on gas leakage and various details, and then charge the air conditioning system with refrigerant.

Standard Amount of Refrigerant 1.55 lbs (700 g)

CAUTION

Never rotate the compressor before charging the air conditioning system with refrigerant.

* ADJUSTMENT OF ENGINE REVOLUTION

The engine idling speed should be adjusted as described below.

- A) Warming up the engine before adjusting the idling speed.
- B) Check the initial ignition timing and initial idling speed.
If necessary, adjust them.
- C) Under the above conditions, operate the air conditioner and then check the fast idle speed with tachometer.

Fast idle speed: 950 rpm

N-range	
Compressor	ON
VSV	ON

- D) When the fast idle speed deviates from specified range, adjust it by screwing the idle adjusting screw. See Fig. 40.

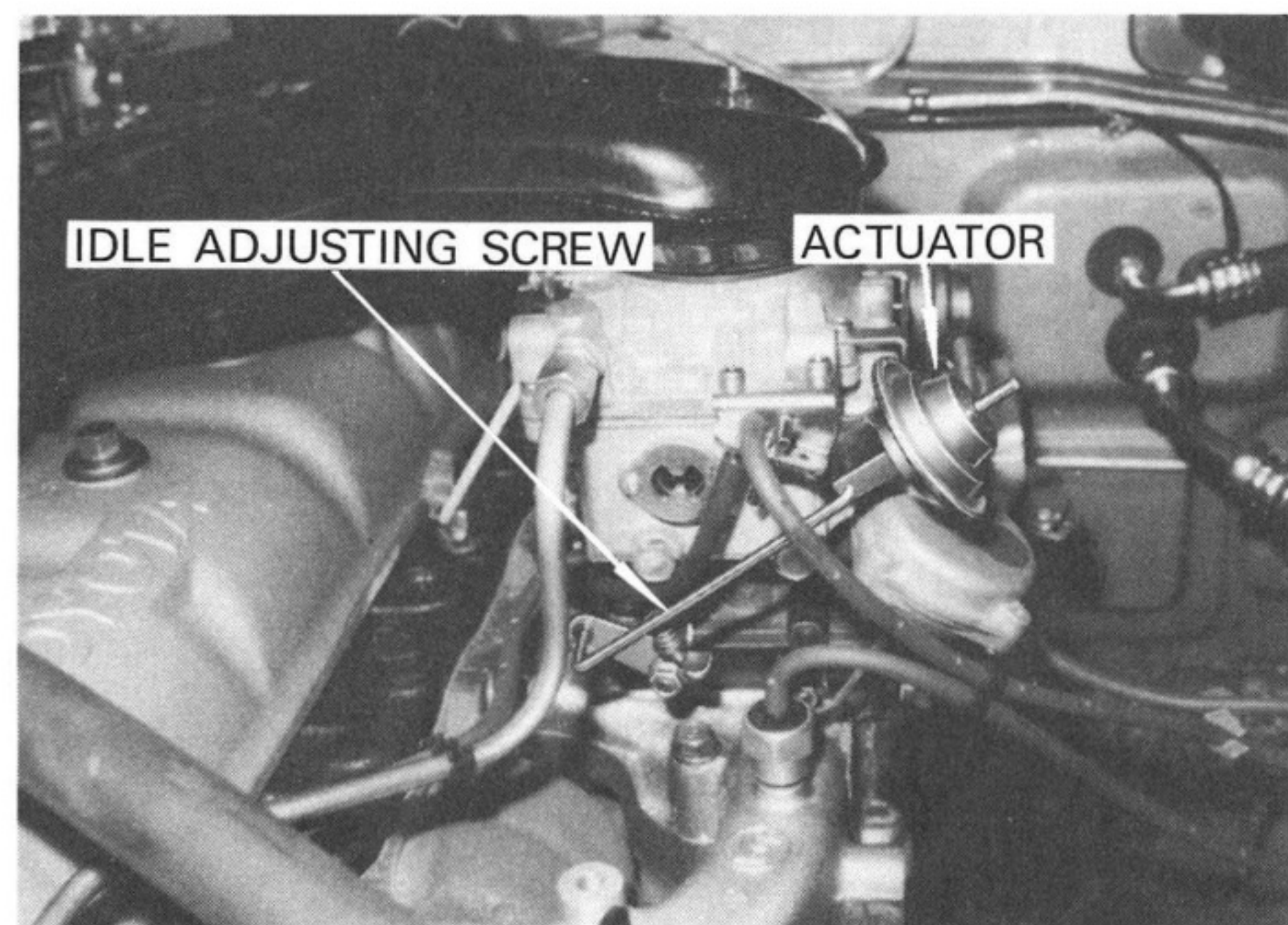

Fig. 40

I EVACUATING AND CHARGING METHOD

1. INSTALLING THE GAUGE MANIFOLD SET

- A) The fittings for attaching the gauge manifold set are located on the compressor service valves. Each service valve has a schrader type valve as shown in Fig. 1. To open this valve the charging hose end, with pin attached, should be fitted to the compressor.

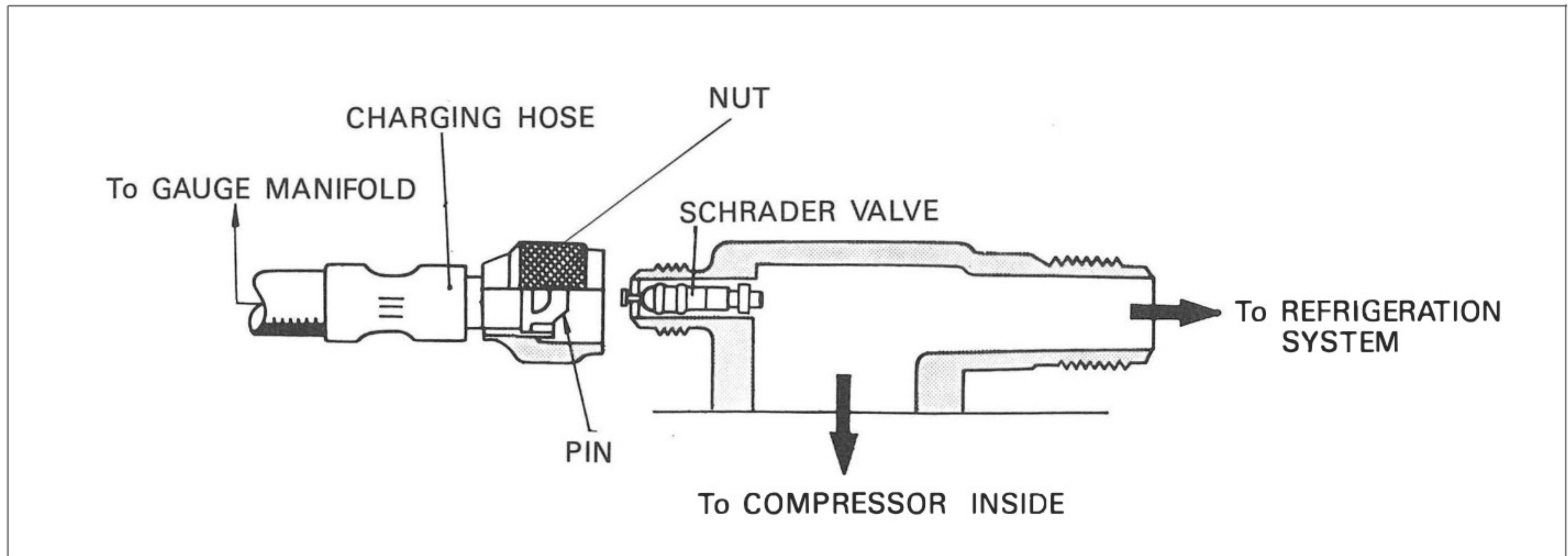

Fig. 1

- B) Ensure that both hand valves on the gauge manifold set are tightly closed.
- C) Remove the valve caps from the service valve fittings. Screw these onto the blind fittings of the gauge manifold set so that they are not lost.
- D) Install the charging hoses of gauge manifold set onto the suction and discharge service valves, respectively.

Note: When connecting charging hoses

- 1) Do not apply any drops of refrigeration oil to the seat of connection.
- 2) Tighten hose nuts by hand.
- 3) Be sure to connect the charging hose end with pin to the compressor service valve.
- 4) Make sure that the hoses are on the relevant compressor fittings:

2. EVACUATING THE SYSTEM

- A) Whenever an air conditioning system has been opened (exposed to atmosphere), it must be evacuated by use of a vacuum pump.
- After installation, it is recommended that the system should be evacuated for approximately 15 minutes.

- B) Connect the high and low charging hoses of gauge manifold set to the hose fittings of both compressor service valves.

Note: *High charging hose should be connected to the discharge service valve fitting. (Discharge service valve is marked "D".)*

- C) Install the center charging hose of gauge manifold set to the vacuum pump inlet. See Fig. 2.

- D) Run the vacuum pump, then open the suction side hand valve. If there is no blockage, and both

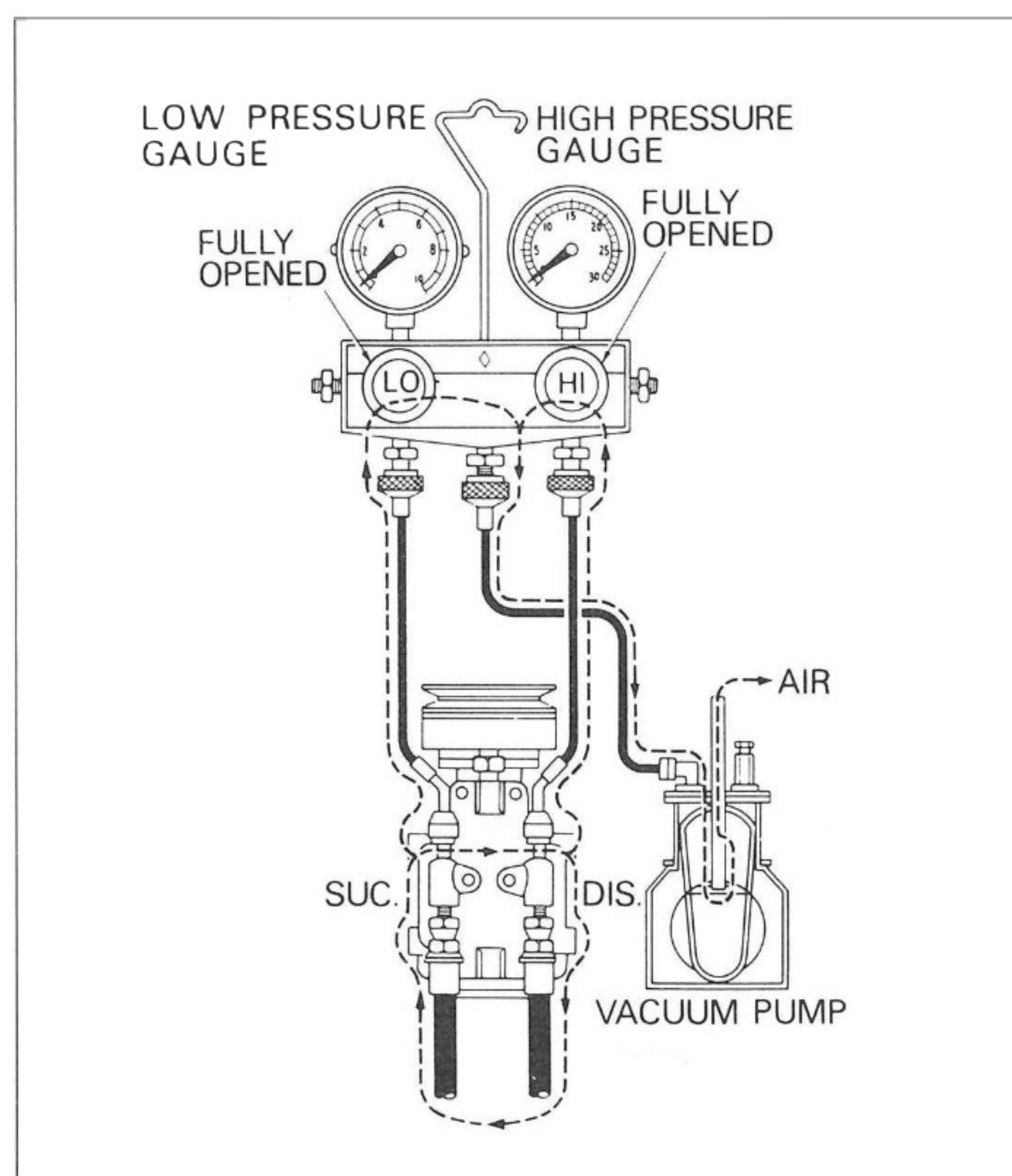

Fig. 2

shradder valves are open, a vacuum should start to appear on the high pressure gauge. If this happens, open the other hand valves.

- E) After about 10 minutes, the low pressure gauge should read greater than 60–70 cm-Hg (24–27 in-Hg) vacuum. This will occur if there is no leak.

Note: 1) *If the system is not down to 60 – 70 cm-Hg (24 – 27 in-Hg) vacuum, close both hand valves and stop the vacuum pump. Watch the low pressure gauge for movement.*

2) *An increase in low pressure gauge reading (i. e. less vacuum) means that there is a leak. This must be repaired before continuing the evacuation.*

3) *If the gauge remain steady continue pumping down.*

- F) Continue evacuating for at least 15 minutes.

- G) After evacuating the system until low pressure gauge indicates about 70 cm-Hg (27 in-Hg) vacuum, then close the both hand valves.

- H) Stop the vacuum pump, then disconnect the center charging hose from the vacuum pump inlet. The system is now ready for charging after it is evacuated as above.

3. HANDLING THE CAN TAP VALVE

- A) Before putting the can tap valve on the refrigerant container, turn the handle out counterclockwise until the valve needle is fully retracted.

- B) Turn the plate nut (locking disc) counterclockwise until it reaches its highest position, and then screw down the can tap valve onto the refrigerant container.

See Fig. 3.

- C) Turn the plate nut clockwise fully and install the center charging hose to the valve fitting of can tap valve.

Note: *The plate nut need only be hand tightened.*

- D) Holding the body of the can tap valve, turn the handle clockwise thus piercing a hole in the top of the container.

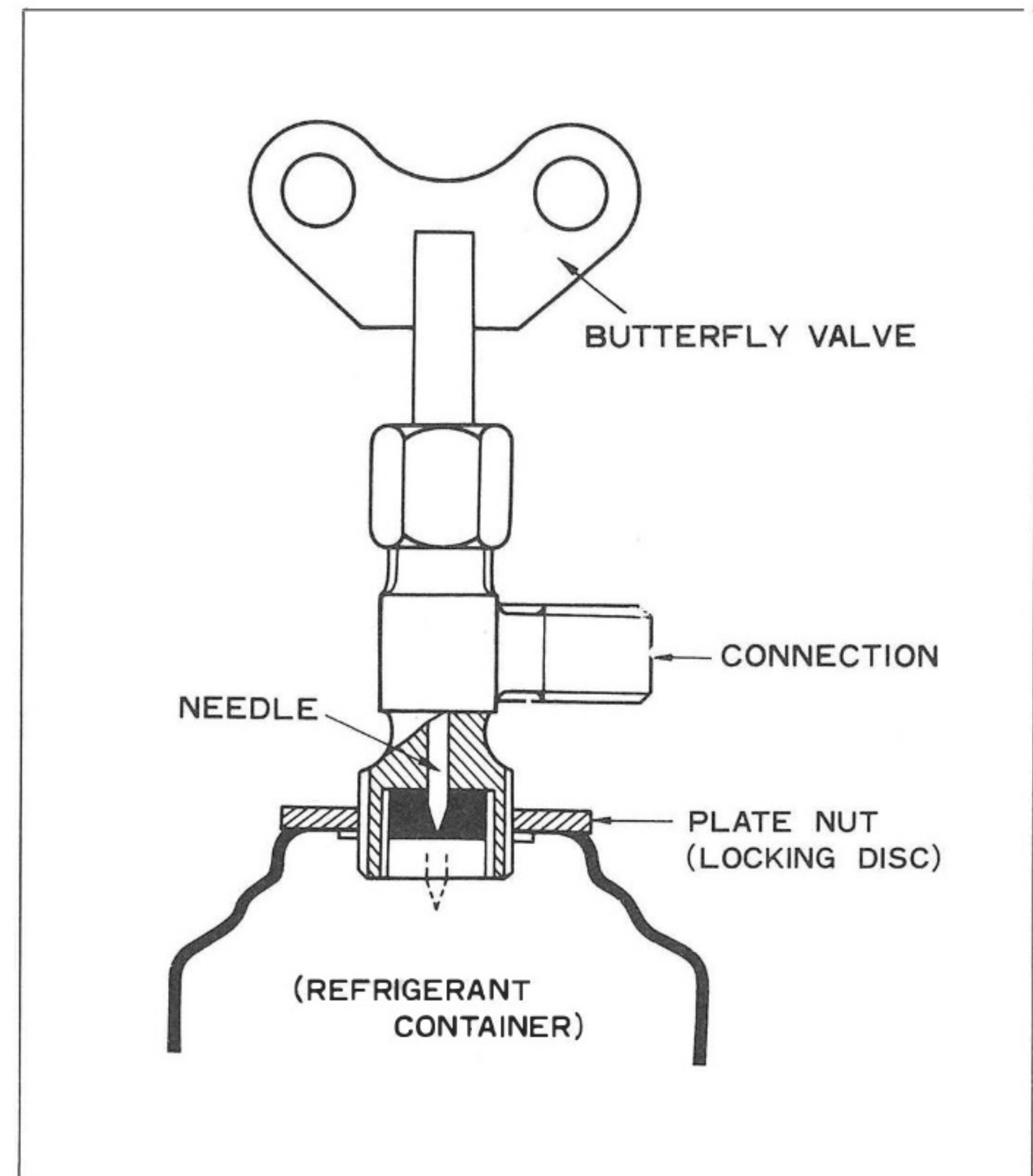

Fig. 3

- E) To charge the system with refrigerant, turn the handle of the gauge manifold set counterclockwise.

To stop the charge, turn it clockwise.

CAUTION

- 1) *When handling refrigerant (R-12), the following precautions must be observed.*
 - A) *Always wear eye protection while handling refrigerant.*
 - B) *The refrigerant container must never be heated.*
Store it below 40 C° (100°F).
 - C) *Do not handle refrigerant in an enclosed area where a naked flame is exposed.*
 - D) *Discharge refrigerant slowly, when purging a system.*
 - E) *Be eareful the liquid refrigerant does not contact skin.*
- 2) *If liquid-refrigerant strikes eye or skin.*
 - A) *Do not rub the affected area.*
 - B) *Splash large quantities of cool water on the eye or skin.*
 - C) *Apply clean petroleum jelly to the skin.*
 - D) *Rush the patient to a doctor or hospital for immediate professional treatment.*
 - E) *Do not attempt to treat the patient by yourself, but seek expert attention.*

4. LEAK TESTING THE SYSTEM

After finishing the evacuation of the system, check the system for leaks using a gas leak detector as described below.

- A) Attach the can tap valve to the refrigerant container. (See section 3.)
- B) Install the center charging hose of the gauge manifold set to the hose fitting of can tap valve, then pierce the refrigerant container by screwing the can tap valve butterfly handle down in clockwise.
- C) Holding the tap body, unscrew its handle counterclockwise fully. Now the center charging hose is filled with air and refrigerant. Do not open the hand valves on gauge manifold set at this point.

- D) Loosen the center charging hose nut on the gauge manifold set until a hiss can be heard.

Allow the air and refrigerant a few seconds to escape, and then tighten the hose nut.

This same operation can be done with the schrader valve in the gauge manifold set.

- E) Open the high side hand valve on gauge manifold set to charge the system with refrigerant vapor.

- F) When the low pressure gauge reads 1 kg/cm (14 psi), close the high side hand valve. Now check the system for leaks using a halide gas leak detector or electric leak detector.

- G) When gas leak is found, the defective components or connections should be repaired.

- H) After checking and repairing the system for leaks, evacuate the system again as outlined below.

- a) Turn the can tap valve handle clockwise fully to close the opening hole on refrigerant container.
- b) Disconnect the center charging hose from the can tap valve fitting.

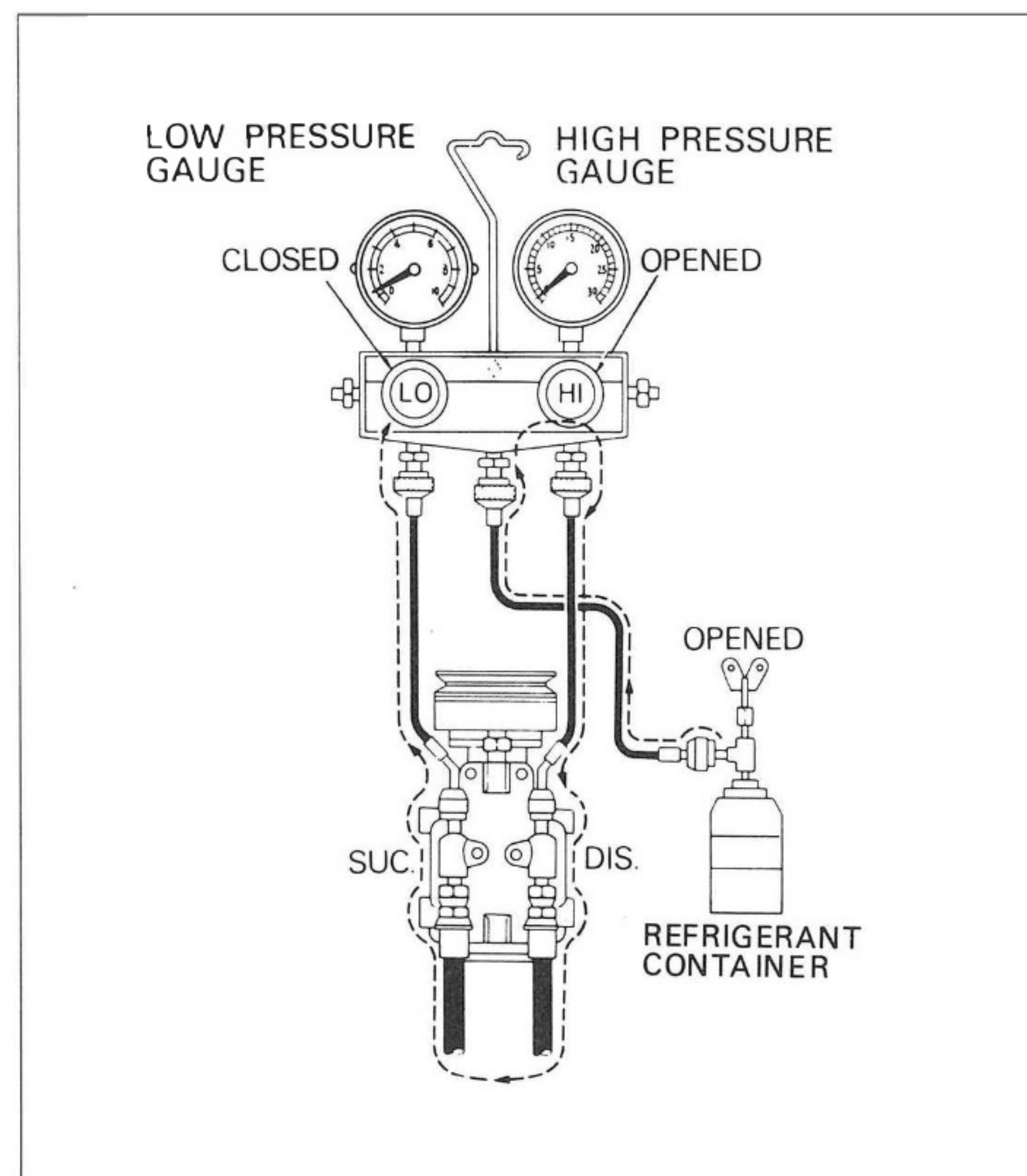

Fig. 4

- c) Connect the center charging hose to the vacuum pump inlet, and continue pumping down as described in Section 2.

Note: *Evacuating time should be at least 15 minutes each time.*

5. CHARGING THE SYSTEM

5-1. Charging an empty system (liquid)

- A) This procedure is for charging an empty system through the high side with refrigerant in a liquid state.

When refrigerant container is held upside down, R-12 will enter the system as a liquid.

CAUTION

- 1) *Never run engine when charging the system through high side.*
- 2) *Do not open low side valve when R-12 is being charged in a liquid state (refrigerant container upside down).*

- B) Close the high and low hand valves of gauge manifold set after the system is completely evacuated.

- C) Connect the center charging hose to the can tap valve fitting, and then loosen the center charging hose at the center fitting on gauge manifold set until a hiss can be heard. Allow the air and refrigerant to escape for a few seconds and tighten the hose nut.

- D) Open the high side hand valve fully and keep the container upside down to charge the refrigerant in liquid state from the high pressure line.

Note: *Do not open the low side hand valve.*

- E) Charge the refrigerant in liquid state to specified amount.

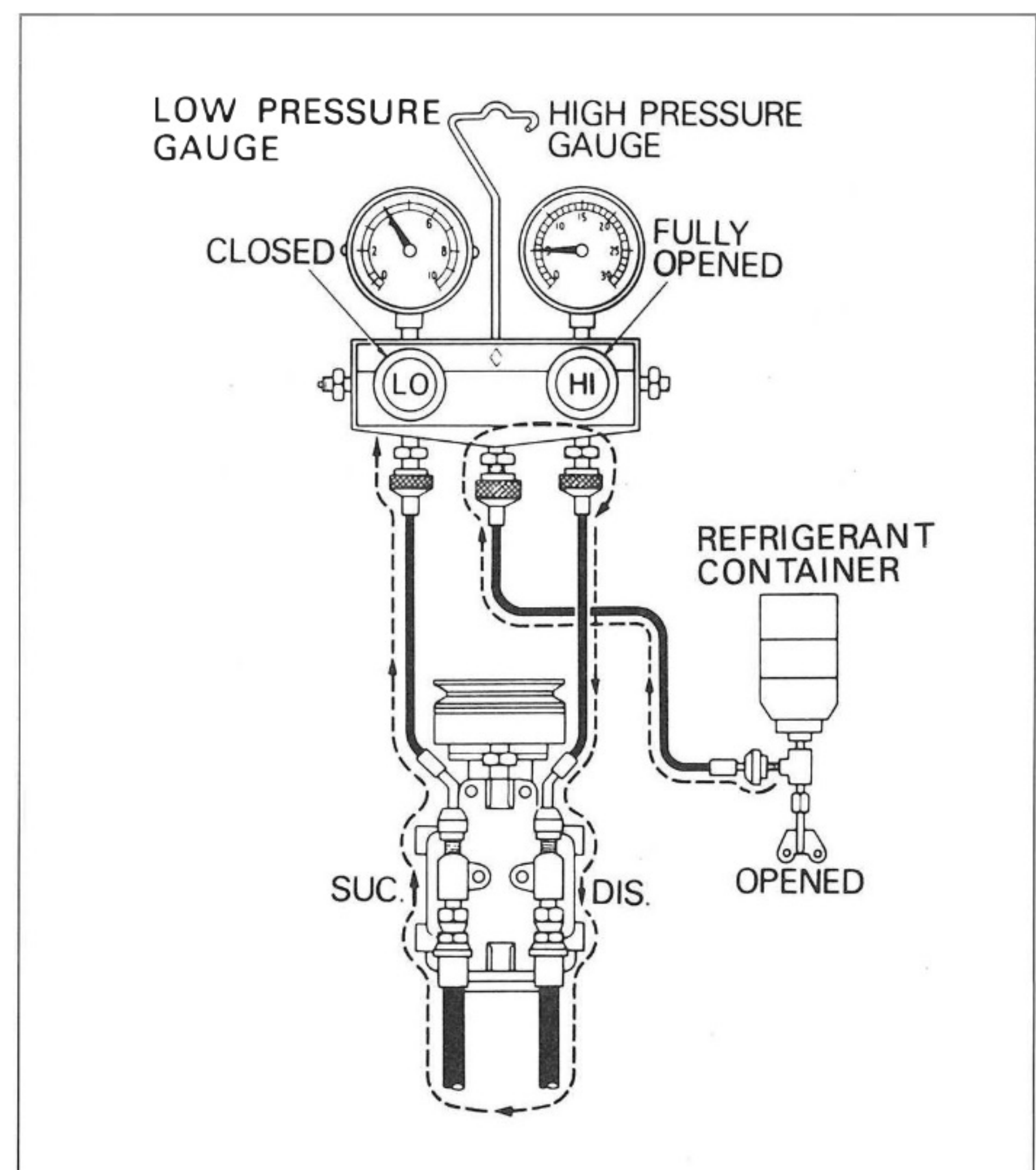

Fig. 5

5-2. Charging a partially charged system (vapor)

A) This procedure is for charging a system, which is charged more than one can (400g, 0.8 lb), through the low side with refrigerant in a vapor state.

When refrigerant container is held right-side up, R-12 will enter the system as a vapor.

CAUTION

- 1) Do not heat the refrigerant container above 40°C (100°F).
- 2) Be sure to close the high side valve of gauge manifold set when engine is running.

B) With gauge manifold set connected and charging line purged, open the low side valve.

C) Start engine and run it at fast idle. Operate the air conditioner.

D) Charge the refrigerant in vapor into the system.

Be sure to keep the container in upright position in this charging method. This is to prevent the liquid refrigerant from being charged into the system through the suction service valve of compressor. See Fig. 6.

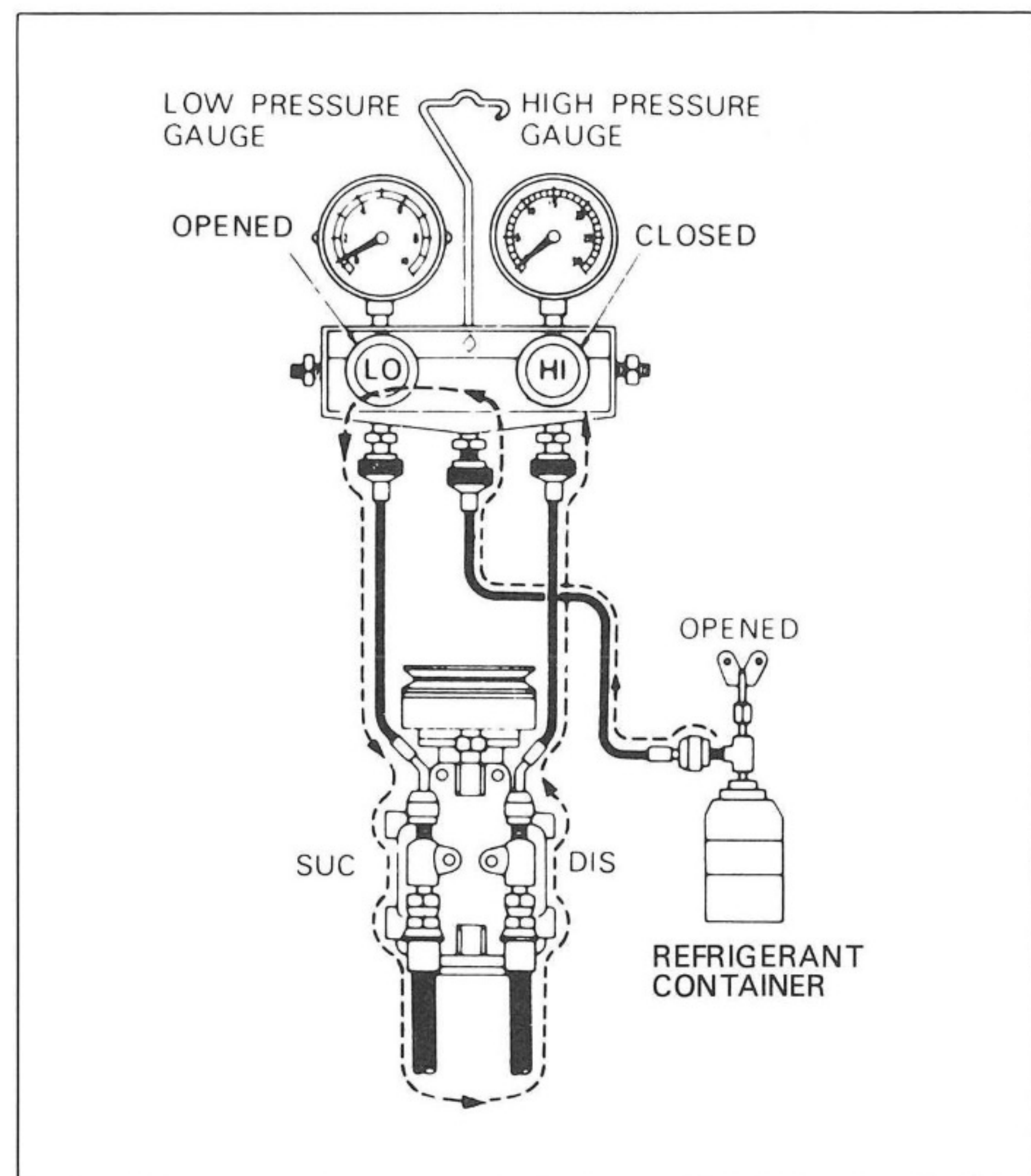

Fig. 6

Note: Liquid refrigerant entering suction chamber of the compressor may cause serious damage to internal component parts of compressor.

E) After charging the specified amount of refrigerant into the system, close the low side hand valve on gauge manifold set.

Sight glass should be free of any bubbles, which indicates a fully charged system.

5-3. Removing a gauge manifold set

A) When system is fully charged to specified amount, the gauge manifold set should be removed as follows :

- 1) Close both high and low side valves on gauge manifold set.
- 2) Close can tap valve.
- 3) Turn off engine.
- 4) Using a shop rag, remove high and low charging hoses from compressor service valves.

Remove them quickly.

B) Put the caps on the service valves of compressor.

CAUTION

High side line is under high pressure and care must be used to protect eyes and skin.

5-4. Replacing a refrigerant container

A) When the refrigerant container is empty, close the both hand valves of gauge manifold set, and remove the can tap valve from the container.

Attach the can tap valve to a new refrigerant container and purge the air in the center charging hose. See Fig. 7.

B) Pierce the top of the refrigerant container, and charge the refrigerant into the system.

(See Section 3.)

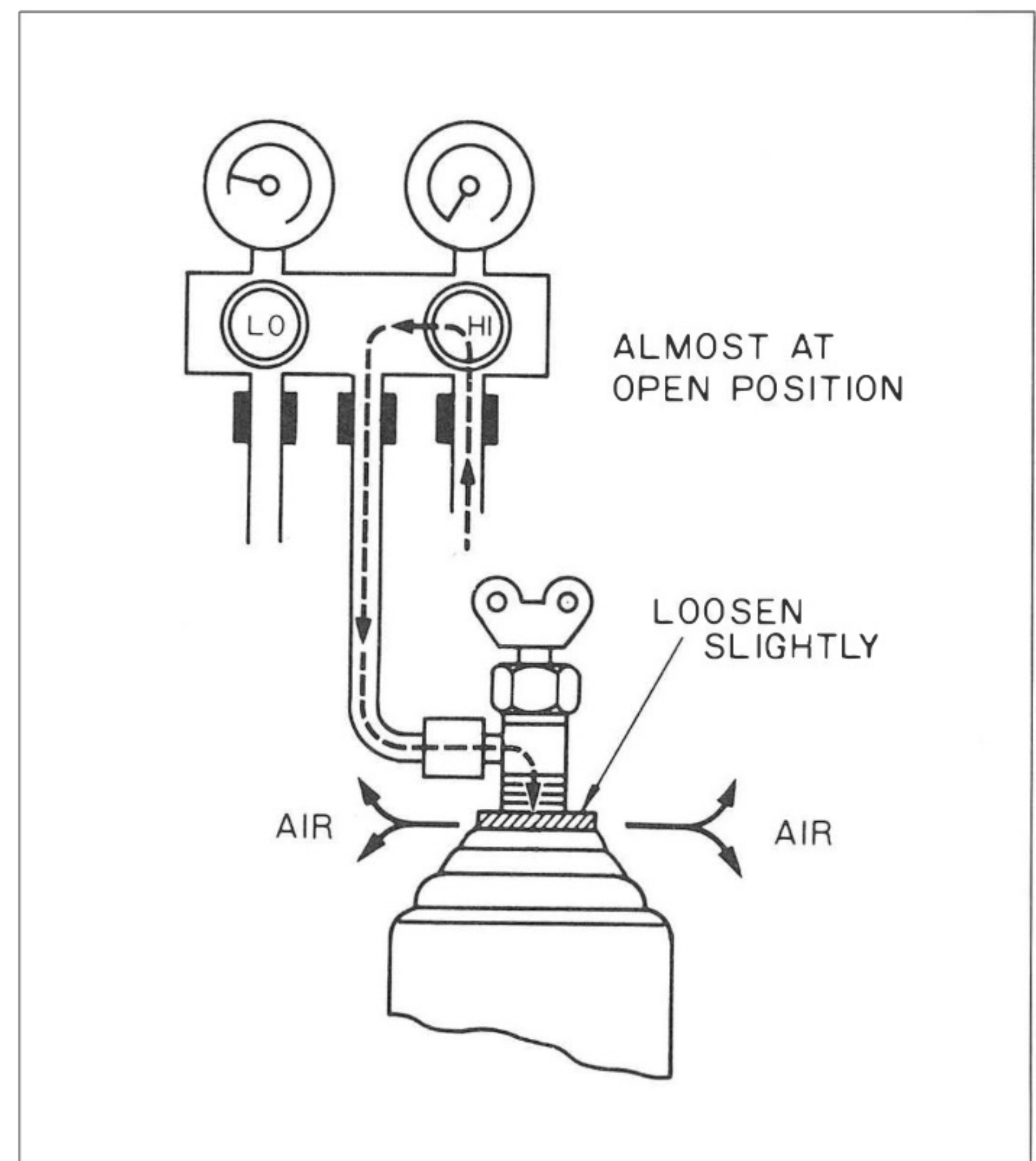

Fig. 7

II PRE-DELIVERY INSPECTION

1. CHECK OF IDLING STABILIZER AMPLIFIER

After charging the system fully, check the cut-off engine revolution of magnetic clutch disengagement, when the air conditioning system is equipped with idling stabilizer amplifier.

Note: *The air conditioning system equipped with the idle speed control device does not need this adjustment.*

- A) Start engine and operate the air conditioner.
- B) Press the accelerator pedal slightly to increase the engine revolution and be sure that the compressor is running.
- C) Release the accelerator pedal gradually and check the clutch cut-off engine revolution.

Standard cut-off rpm : 650 ± 50 rpm

- D) When the cut-off engine revolution deviates from the standard :

- a) If the cut-off revolution is too high :

Turn the shaft of cut-off rpm setting resistor clockwise.

(See Fig. 8.)

- b) If the cut-off revolution is too low :

Turn it counterclockwise.

(See Fig. 8.)

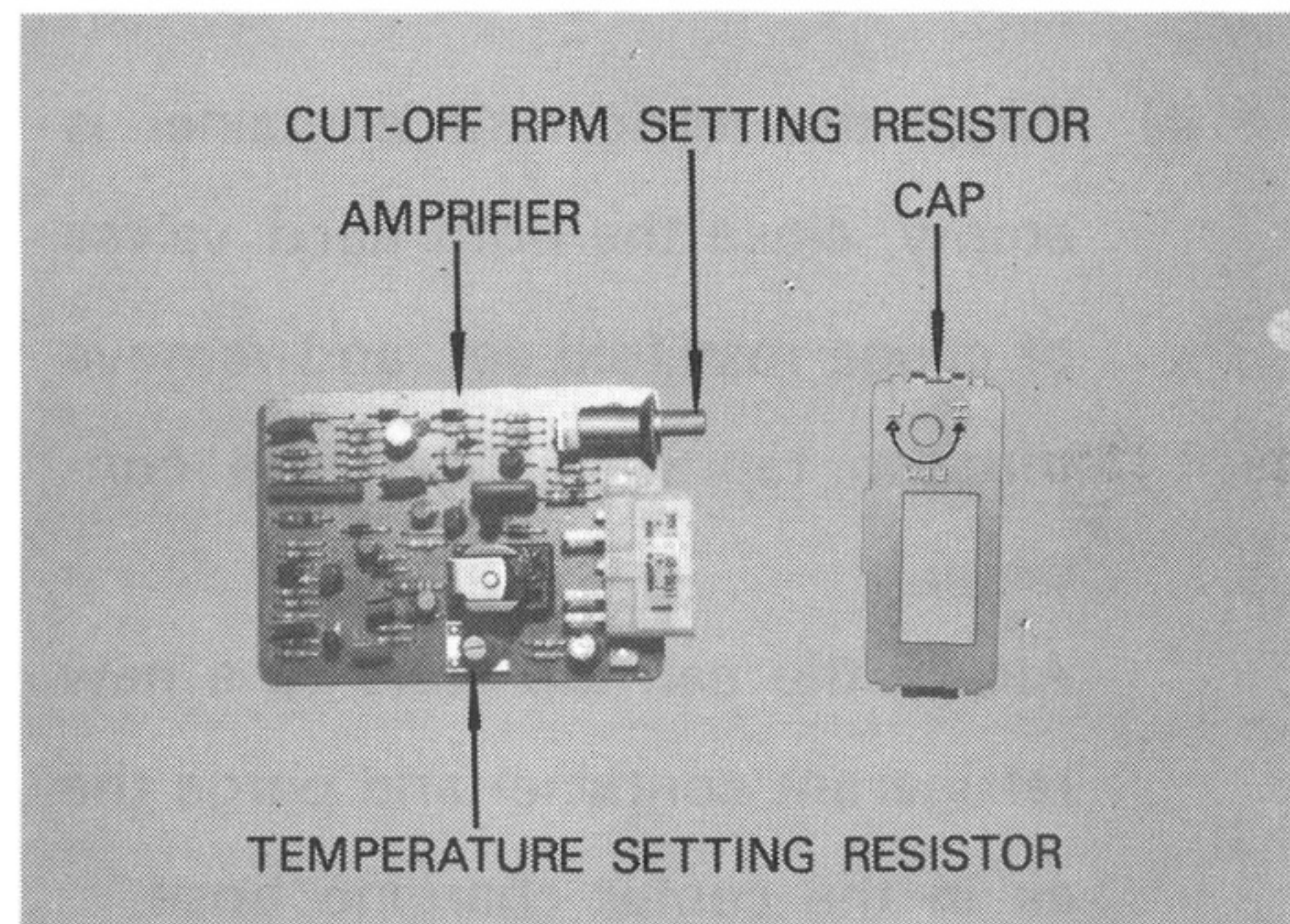

Fig. 8

2. VARIOUS INSPECTIONS

- 1) Check if :
 - A) the ventilators will close completely.
 - B) component parts of the car operate normally.
 - C) any abnormal noise occurs when running.

- 2) Adjust the belt tension if required.

Now, the air conditioner is ready for use.

Be sure to explain operation and maintenance to owner.

Refer to "Owner's Manual".