

TOYOTA

2F ENGINE

REPAIR MANUAL

TOYOTA MOTOR CORPORATION

Pub. No. 89-27E

TOYOTA

2F ENGINE

REPAIR MANUAL

TOYOTA MOTOR CORPORATION

Pub. No. 98126E

TOYOTA

4A ENGINE

INTAKE MANIFOLD

INTAKE MANIFOLD

©1991 TOYOTA MOTOR CORPORATION
All rights reserved. This book may not be reproduced or copied, in whole or in part, without the written permission of Toyota Motor Corporation.

FOREWORD

This manual describes the repair procedures for the 2F engine equipped on the TOYOTA LAND CRUISER and TRUCKS.

Under DISASSEMBLY and ASSEMBLY, you will find disassembled views which carry numbers indicating the sequence of operation procedure. The operations can be accomplished by following these numbers. To facilitate understanding, there are also some figure numbers after operation numbers showing the locations of work details. The texts have different symbol marks which supersede the figure explanation.

This manual provides complete information on the maintenance and service of this engine, and it is hoped that it will see much use.

Specifications contained herein are based on the December, 1974 production model. For specifications on other models, please refer to the respective Specification Manual.

Also for vehicles equipped with an emission control device, please refer to the Emission Control Repair Manual.

TOYOTA MOTOR CORPORATION

CONTENTS

| NAME | SECTION |
|---------------------------------|-----------|
| GENERAL | 1 |
| ENGINE TUNE-UP | 2 |
| ENGINE SERVICE | 3 |
| LUBRICATING SYSTEM | 4 |
| COOLING SYSTEM | 5 |
| FUEL SYSTEM | 6 |
| STARTING SYSTEM | 7 |
| IGNITION SYSTEM | 8 |
| CHARGING SYSTEM | 9 |
| SST & SPECIFICATIONS | 10 |

GENERAL

Page

GENERAL REPAIR INSTRUCTIONS.....1-2

ABBREVIATIONS USED IN THIS MANUAL1-3

SYMBOL MARKS.....1-4

1

GENERAL REPAIR INSTRUCTIONS

1. Use fender, seat and floor covers to keep the car clean and prevent damage.
2. During disassembly, keep parts in order to facilitate reassembly.
3. Before performing electrical work, disconnect the cable from the battery terminal.
4. Always replace cotter pins, gaskets and O rings with new ones.
5. When necessary, use a sealer on gaskets to prevent leaks.
6. Carefully observe all specifications for bolt tightening torques. Always use a torque wrench.
7. Use genuine Toyota parts.
8. When replacing fuses, be sure the new fuse is the correct amperage rating. DO NOT exceed the fuse amp rating or use one of a lower rating.
9. If the vehicle is to be jacked up only at the front or rear end, be sure to block the wheels in order to ensure safety.
10. After the vehicle is jacked up, be sure to support it on stands. It is extremely dangerous to do any work on the vehicle raised on jack alone, even for a small job that can be finished quickly.
11. Use of a special service tool (SST) may be required, depending on the nature of the repair. Be sure to use SST where specified and follow the proper work procedure. A list of SST can be found at the back of this manual.









ABBREVIATIONS USED IN THIS MANUAL

For convenience, the following codes are used in this manual.

| Abbreviation | Term | Definition |
|--------------|------------------------|--|
| SST | Special Service Tool | This term designates tools that have been manufactured specially for the servicing of this vehicle. Their part numbers are shown in the text enclosed by [] . |
| STD | Standard | This term refers to the dimension of the part when originally manufactured. |
| O/S | Oversize | Sizes larger than STD are indicated as O/S. |
| U/S | Undersize | Sizes smaller than STD are indicated as U/S. |
| MP | Multipurpose | Use in the case of MP grease. |
| BTDC | Before Top Dead Center | |
| T/M | Transmission | |

SYMBOL MARKS

The following symbols have been adapted for simplicity and for easy comprehension.

| | | | |
|---|--------------------|--|--|
|  | ASSEMBLE | | |
|  | DISASSEMBLE | | |
|  | INSTALL | | |
|  | REMOVE | | |
|  | INSPECT | | |
|  | MEASURE | | |
|  | TIGHTEN | | |
|  | CLEAN | | |
|  | IMPORTANT | | |

HERITAGE CRUISER
TECHNICAL SERVICE MANUAL
1964-1966
1967-1968
1969-1970

ENGINE TUNE-UP

| | Page |
|---------------------------|------|
| ENGINE OIL | 2- 2 |
| COOLING SYSTEM | 2- 3 |
| DRIVE BELT | 2- 4 |
| AIR CLEANER | 2- 5 |
| HEAT CONTROL VALVE | 2- 5 |
| BATTERY | 2- 6 |
| SPARK PLUG | 2- 6 |
| HIGH TENSION CORD | 2- 7 |
| DISTRIBUTOR | 2- 8 |
| VALVE CLEARANCE..... | 2-10 |
| CARBURETOR | 2-11 |
| INITIAL IDLE SPEED..... | 2-12 |
| FAST IDLE | 2-14 |
| THROTTLE POSITIONER | 2-14 |
| COMPRESSION PRESSURE..... | 2-15 |

Fig. 2-1

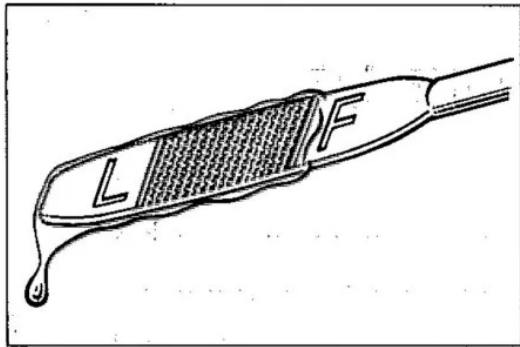

Fig. 2-2

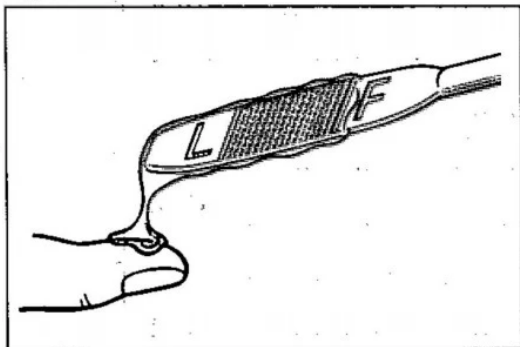

Fig. 2-3

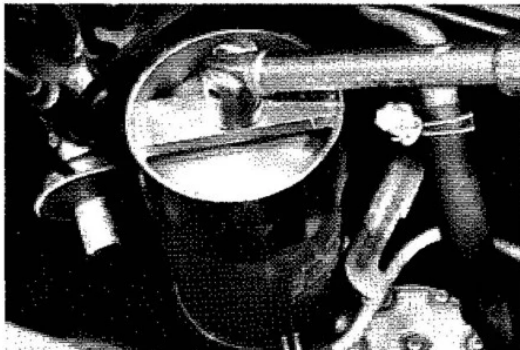

Fig. 2-4



ENGINE OIL

LEVEL CHECK and REPLENISHMENT

Oil level should be up to the F line on the level gauge. If low, add oil up to the F line. Use API service SE classification engine oil.



QUALITY CHECK

Pull out the oil level gauge and examine the oil adhering on the graduated part. The oil should not be discolored or thin.



OIL FILTER REPLACEMENT

1. Remove the oil filter by using SST [09228-44010].
2. For installation, tighten firmly the oil filter by hand.



3. After starting the engine, check for oil leak and recheck the oil level.



Fig. 2-5

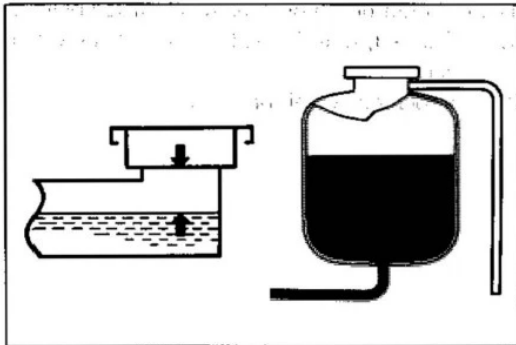

COOLING SYSTEM COOLANT LEVEL CHECK and REPLENISHMENT

If coolant is low, fill reservoir tank up to "Full" line.

Fig. 2-6

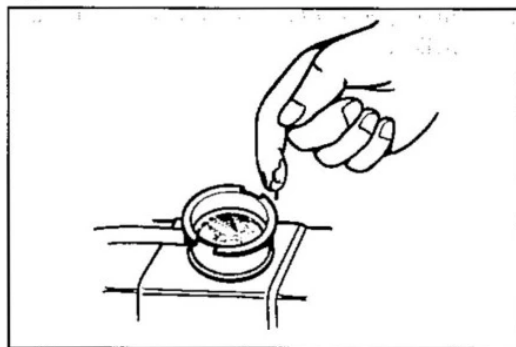

COOLANT QUALITY CHECK

There should not be any excessive deposit of rust or scales around the radiator cap or radiator filler hole, and the coolant should also be free from oil. Replace the coolant if excessively dirty.

Fig. 2-7

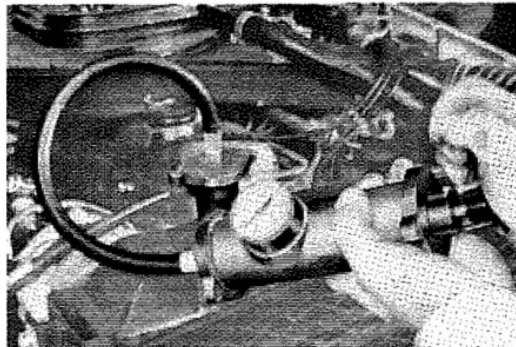

INSPECTION of COOLING SYSTEM PARTS

There should be no defects such as listed below:

1. Damage, deterioration, or loose clamps in radiator hoses, water hoses.
2. Leakage due to corrosion or damage in radiator core.
3. Leakage due to loose water drain cock.
4. Leakage from water pump.

Fig. 2-8

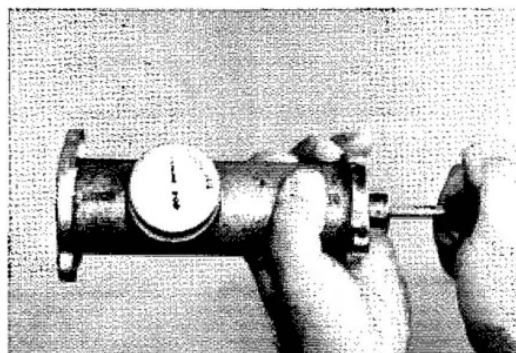

5. Faulty operation of radiator cap.

Inspect the radiator cap pressure regulating and vacuum valves for spring tension and seating condition. If the valve opens at a pressure level below the specified value or is otherwise defective, replace the radiator cap.

Valve opening pressure limit

0.6 kg/cm² (8.5 psi)

Standard

0.9 kg/cm² (12.8 psi)

Fig. 2-9

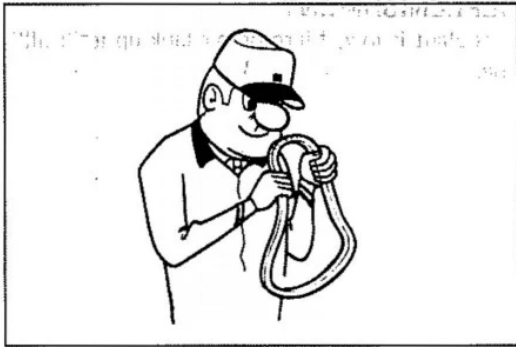

Fig. 2-10

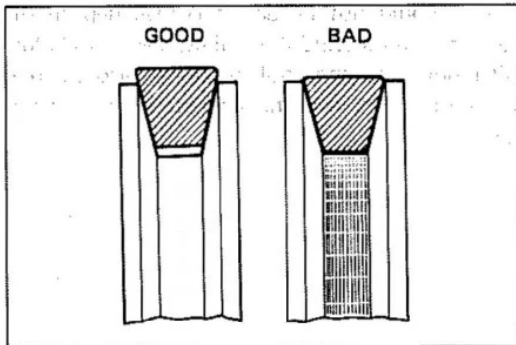

Fig. 2-11

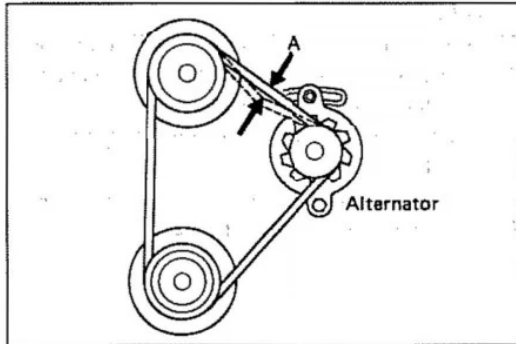
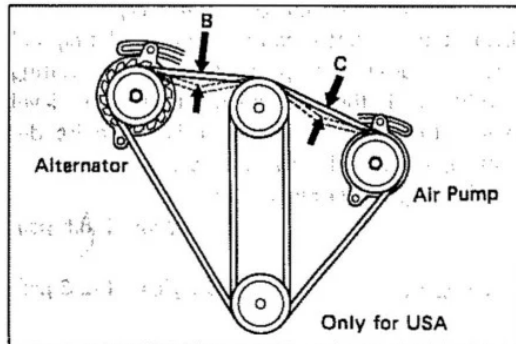

Fig. 2-12



DRIVE BELT VISUAL CHECK

There should be no defects such as listed below:



1. Cracked, deteriorated, stretched, or worn belt.
2. Adherence of oil or grease.



3. Improper contacting of belt against the pulley.

TENSION CHECK and ADJUSTMENT



When the belt is pressed down with 10 kg (22 lb) force, the belt should deflect the specified amount.

- A : 7–10 mm (0.28–0.39 in)
- B : 13–15 mm (0.51–0.59 in)
- C : 7–10 mm (0.28–0.39 in)



Fig. 2-13

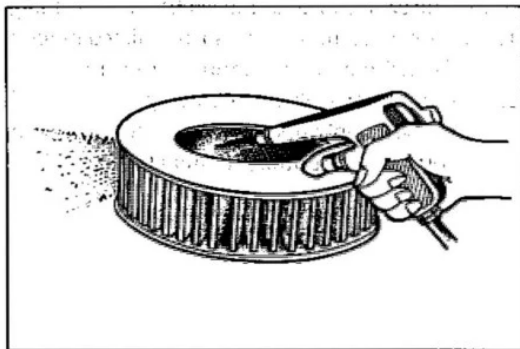

AIR CLEANER ELEMENT CLEANING

1. In removing the air cleaner or element, and after removal, use care not to drop dirt and dust down into the carburetor.
2. In cleaning the element, blow air from the inner side.
3. In case the element is torn or excessively dirty, replace with new one.



Fig. 2-14

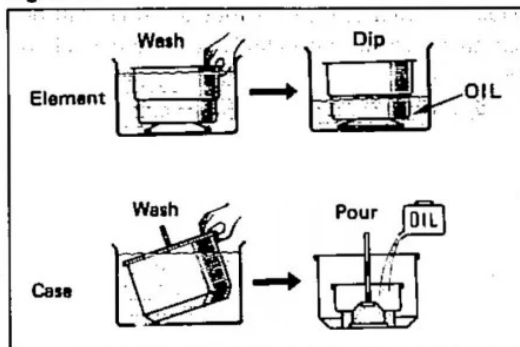

Oil Bath Type

Wash the element and case with cleaning solvent, and dry them thoroughly before reuse. Fill the case with engine oil to its specified level.



Fig. 2-15

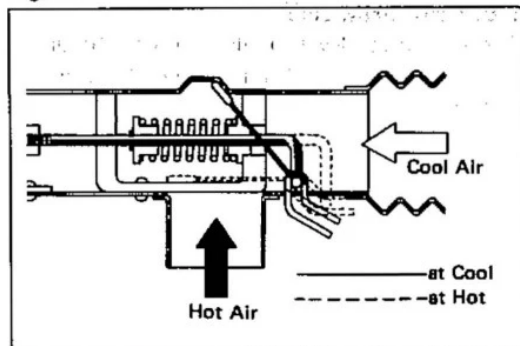

HOT AIR INTAKE

Check air control valve operation. Valve should close cold air intake when cold, hot air intake when warm.



Fig. 2-16

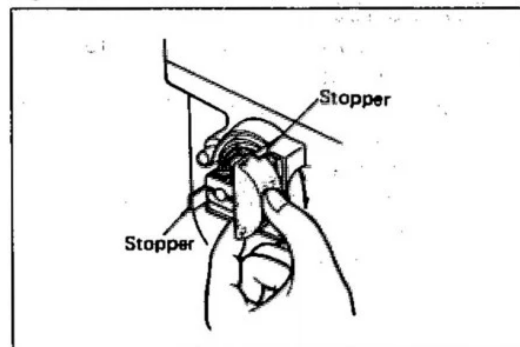

HEAT CONTROL VALVE INSPECTION

When the heat control valve shaft is turned by hand, the valve should move smoothly to the stopper, and when released, it should return to the other stopper.



Fig. 2-17

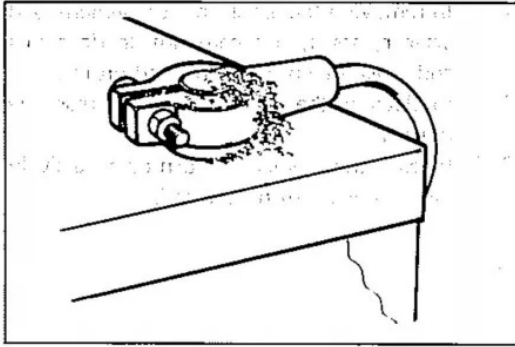

Fig. 2-18

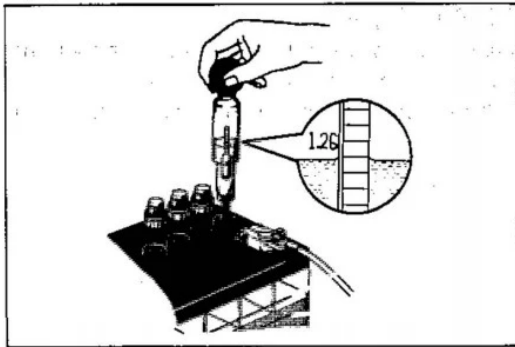

Fig. 2-19

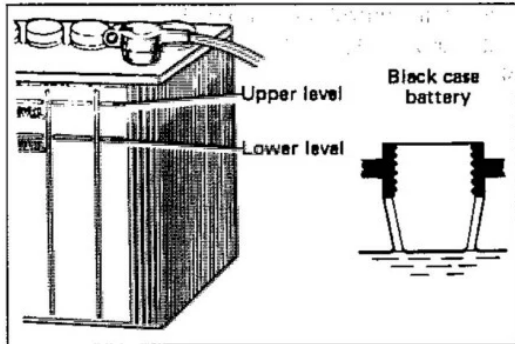
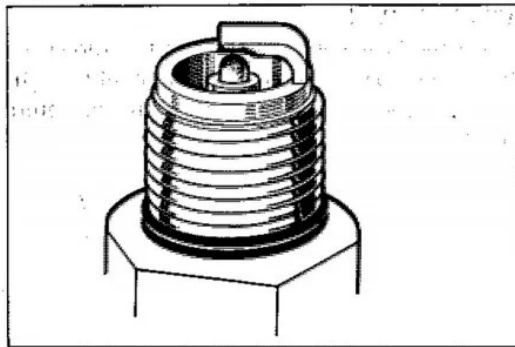

Fig. 2-20



BATTERY VISUAL CHECK



If very dirty, remove and clean before checking. There should be no defects such as listed below:

1. Rusted battery mounting hardware.
2. Damage or leakage in battery.
3. Loose connection, rusting, deterioration or corrosion of battery terminals.

SPECIFIC GRAVITY MEASUREMENT



Hold the hydrometer so that the float will not contact against the cylinder wall and read the graduation.

Specific gravity 1.25–1.27

ELECTROLYTE LEVEL CHECK and REPLENISHMENT



The electrolyte level should be up to the upper level. If low, add distilled water (or purified water).

SPARK PLUG VISUAL CHECK



Condition is good if none of the following defects are present.

1. Cracks or damages in the threads or insulator.
2. Wear on the electrodes.
3. Damaged or deteriorated gaskets.
4. Burnt condition of electrode and undesirable carbon deposit.

Fig. 2-21

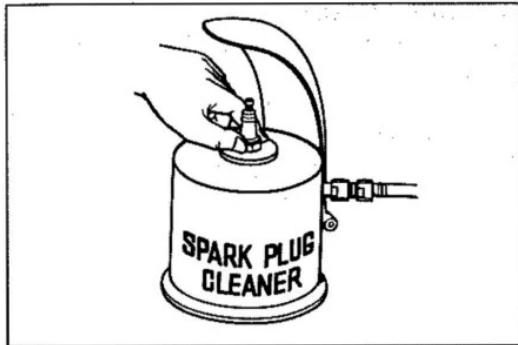

Fig. 2-22

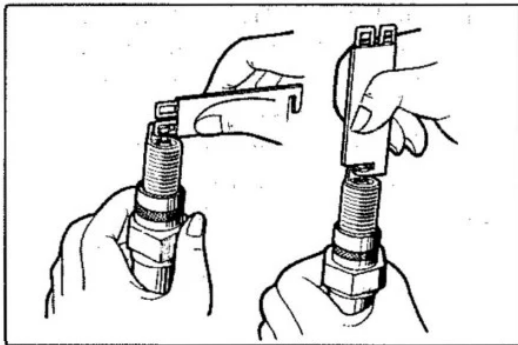

Fig. 2-23

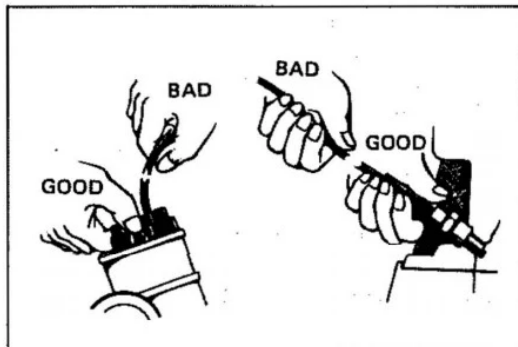
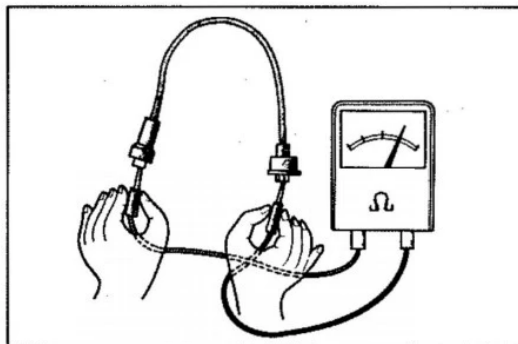

Fig. 2-24

**CLEANING**

1. Do not use spark plug cleaner longer than necessary.
2. Blow off cleaning compound and carbon on the threads thoroughly with air.
3. Clean off dirt from the outer surface of insulator and threads.

GAP ADJUSTMENT

Check the plug gap with plug gap gauge. If not to specified value, adjust by bending the ground (outer) electrode.

Plug gap 0.8 mm (0.031 in)
 1.0 mm (0.039 in) for USA

HIGH TENSION CORD

– Note –

When pulling out the spark plug cord from the plug, always grip the end of plug cord.



Check the resistance of resistivity cord.

Resistance Less than 25 kΩ per cord.

Fig. 2-25

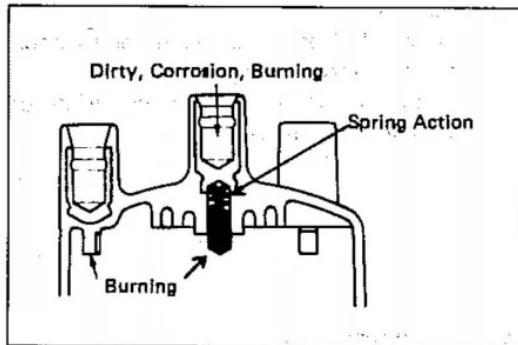

Fig. 2-26

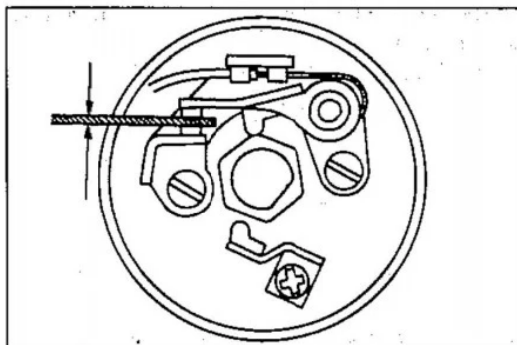

Fig. 2-27

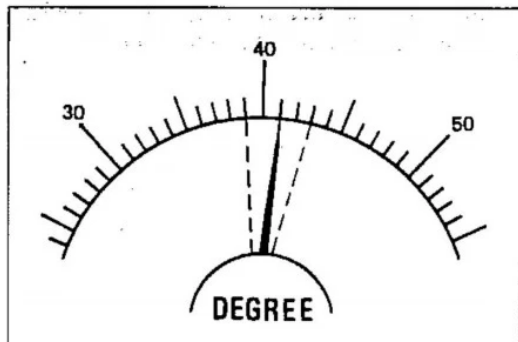
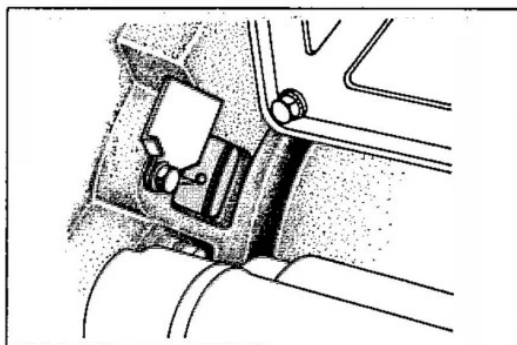

Fig. 2-28



DISTRIBUTOR CAP INSPECTION



Clean the distributor cap and inspect the cap and rotor for:

1. Cracks, damage, dirty cord hole, corrosion, burning.
2. Center piece spring action.
3. Burnt electrode terminal.

POINT GAP ADJUSTMENT (W/O IGNITER)



1. If the points are excessively burnt or pitted, replace the breaker points.
2. Adjust point gap.

Point gap 0.45 mm (0.018 in)

POINT RUBBING BLOCK GAP ADJUSTMENT (W/IGNITER)

Check the dwell angle. If not as specified, correct it by adjusting the point rubbing block gap.

DWELL ANGLE



Check if dwell angle is within the specified value.

Dwell angle 41° (38 – 44°)

Variation

Within 3° (at idling to 2000 rpm)

— Caution —

On the vehicle equipped with transistorized ignition system, do not connect dwell tacho tester lead to distributor terminal, but to ignition coil terminal to prevent misfire.

IGNITION TIMING



Set the engine revolution at idle speed and align the timing marks by turning distributor body.

Ignition timing

7° BTDC (at idle speed)

The octane selector must be set at standard position.

Fig. 2-29

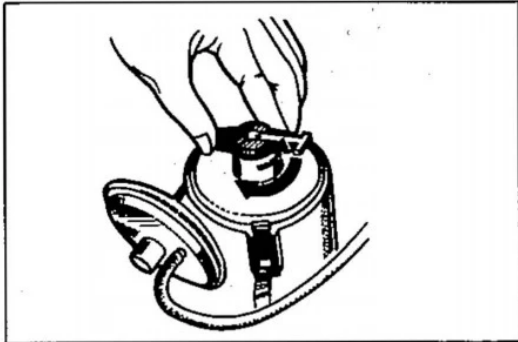
**GOVERNOR OPERATIONAL INSPECTION**

1. Rotor should return quickly when turned clockwise by hand and released.
2. Rotor should not be excessively loose.

Fig. 2-30

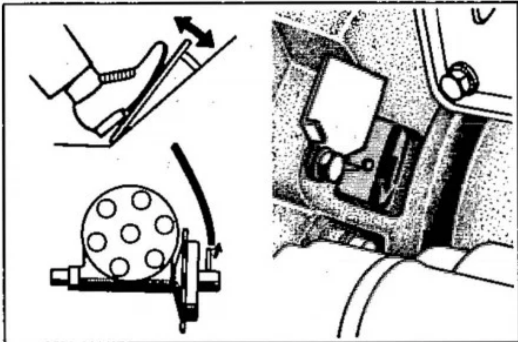

3. Start the engine and disconnect the vacuum hose from the distributor. The timing mark should vary in accordance with the opening and closing of throttle valve.

Fig. 2-31

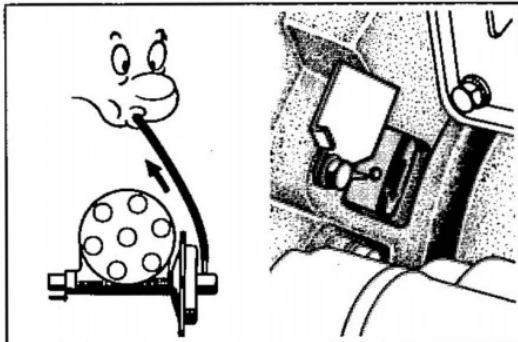
**VACUUM ADVANCE OPERATIONAL INSPECTION (Except for USA)**

Disconnect the distributor vacuum hose and suck the hose with mouth while the engine is idling. Check if timing advances when sucked.

Fig. 2-32

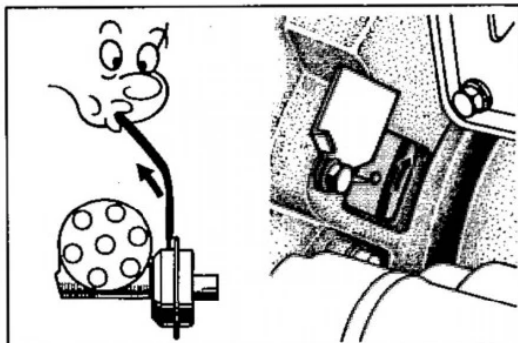
**VACUUM RETARD OPERATIONAL INSPECTION (For USA)**

Disconnect the distributor vacuum hose and suck the hose with mouth while the engine is idling. Check if timing retards when sucked.

Fig. 2-33

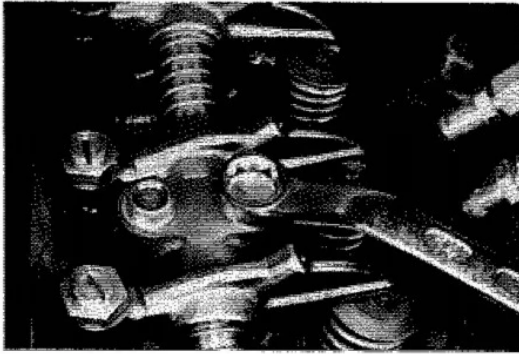

Fig. 2-34

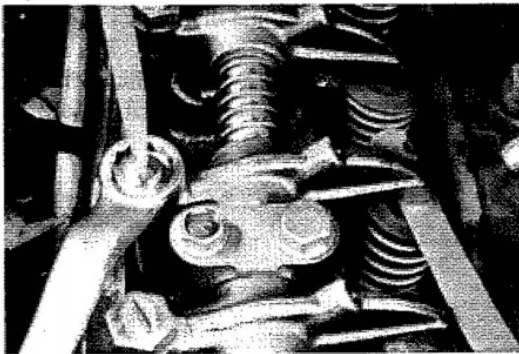

Fig. 2-35

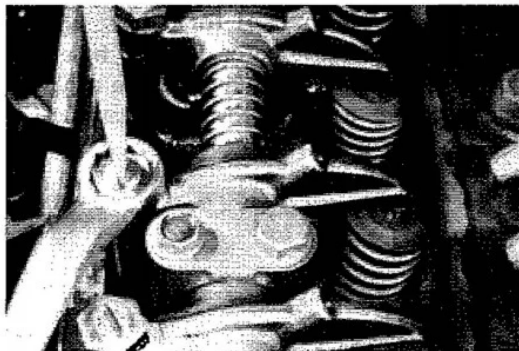
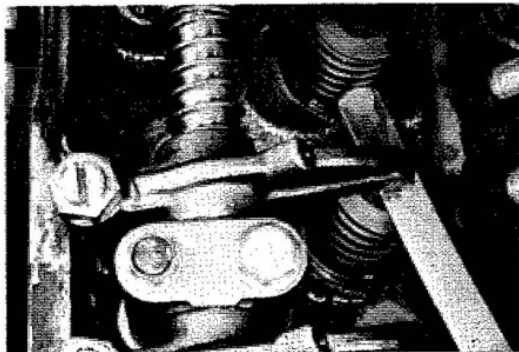

Fig. 2-36



VALVE CLEARANCE



1. Check the coolant temperature, 80°C (180°F)
2. Tighten the rocker support bolts to specified torque.

Torque

3-4.5 kg-m (22-33 ft-lb)



3. Make adjustment.
 - (1) Set the engine at idle speed, and check the valve clearance. Adjust if necessary. Valve clearance (Hot)

| | |
|----------------|---------------------------|
| Intake | 0.20 mm (0.008 in) |
| Exhaust | 0.35 mm (0.014 in) |



- (2) Retighten the lock nuts securely after adjustment.



- (3) Recheck the valve clearance.

Fig. 2-37

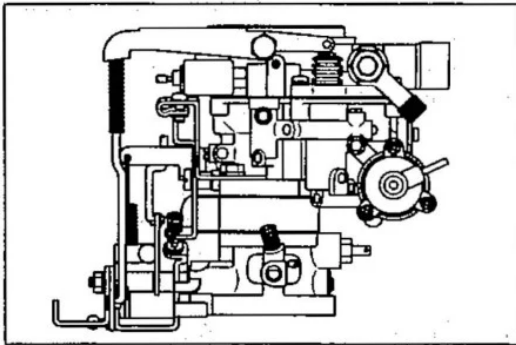

CARBURETOR LOOSENESS and OPERATIONAL CHECK

1. The various set screw, plugs and union bolts should be in properly tightened and correctly installed state.
2. The links should be free from excessive wear, the snap rings (ring pins) should all be present, and the throttle shaft should not be worn.

Fig. 2-38

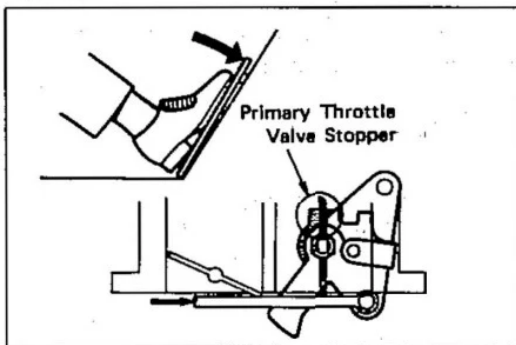

3. Check throttle valve full open. The throttle valve should open fully when the accelerator pedal is stepped all the way down.

Fig. 2-39

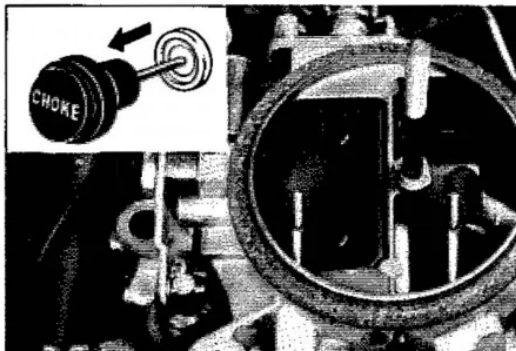

4. Check choke valve action.
 - (1) Choke valve should be fully closed when the choke button is fully pulled.
 - (2) At this time, open choke valve with finger and release it. It should close fully.

Fig. 2-40

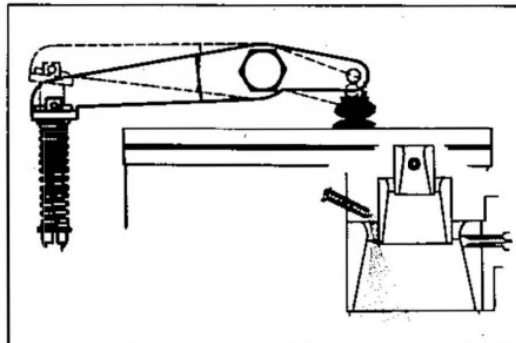

5. Check the accelerating pump operation. Gasoline should shoot out with good force from the jet when the throttle valve is opened.

Fig. 2-41

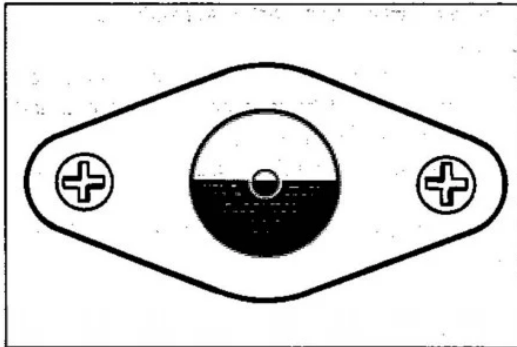

6. Check float level. Float level is satisfactory if the fuel level is up to the standard line when the engine is idling. For adjustment, refer to carburetor section.

INITIAL IDLE SPEED

Check the following items beforehand.

1. Coolant temperature –
Approximately 80°C (180°F)
2. Choke valve – Full open
3. Accessory parts (wipers, heater, lights, air conditioner, etc.,)
– All switched off.
4. Vacuum lines – All lines connected.
5. Ignition timing – Initial set position
6. Transmission – In "N"

BEST IDLE (Except for USA and ECE)

1. Set to 650 rpm by turning the idle speed adjusting screw.

Fig. 2-42

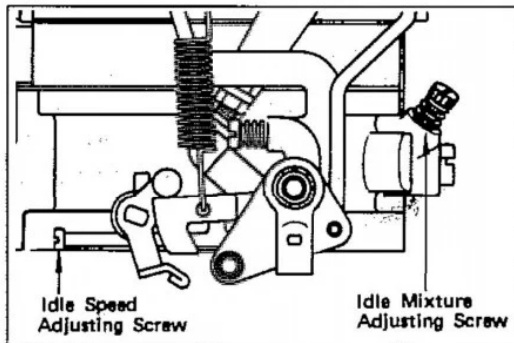
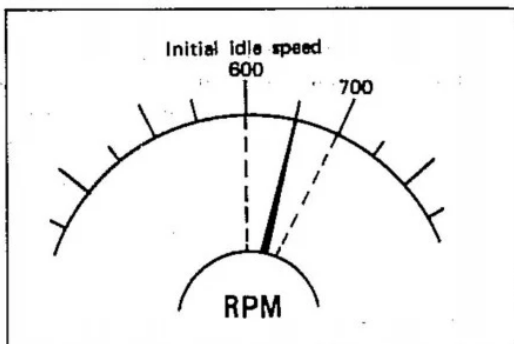

Fig. 2-43



2. Set to the max. speed or max. vacuum by turning the idle mixture adjusting screw.
3. Repeat the above adjustments until the specified rpm and maximum vacuum will be obtained.

Idle speed 650 ± 50 rpm
Vacuum 420 mmHg (16.5 inHg)

Fig. 2-44

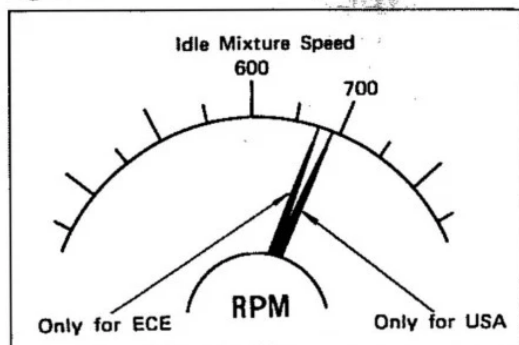

Fig. 2-45

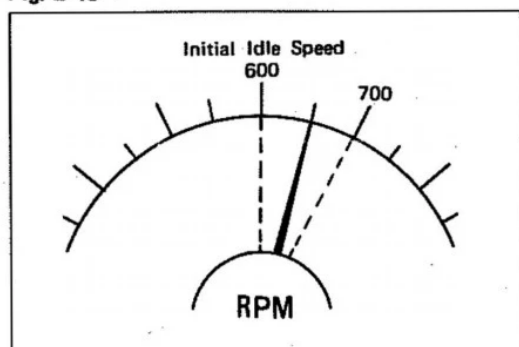

Fig. 2-46

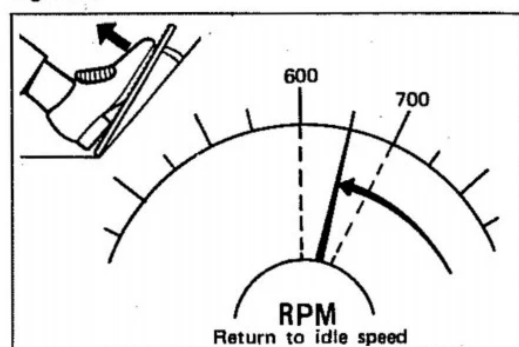
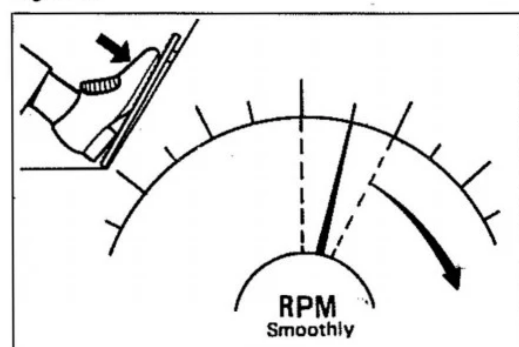

Fig. 2-47



LEAN DROP IDLE (Only for USA and ECE)

1. Set to the maximum speed by turning the idle mixture adjusting screw.
2. Set to the idle mixture speed by turning the idle speed adjusting screw.
3. Keep on repeating the adjustments (1) and (2) until the maximum speed will not rise any further no matter how much the idle mixture adjusting screw is adjusted before moving to the next step.

Idle mixture speed

690 rpm For USA

675 rpm For ECE

4. Set to the initial idle speed by screwing in the idle mixture adjusting screw.

Initial idle speed 650 ± 50 rpm



5. Check if the engine returns to idle speed when suddenly and slowly accelerated.



6. Check the engine condition. Opening throttle valve gradually should cause engine to speed up smoothly in relation to amount of valve opening.

Fig. 2-48

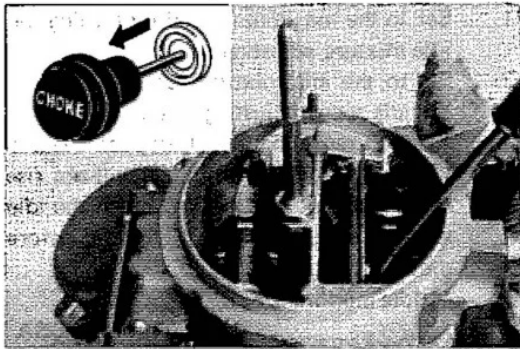

Fig. 2-49

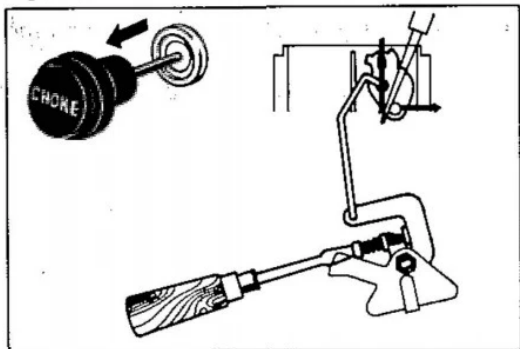

Fig. 2-50

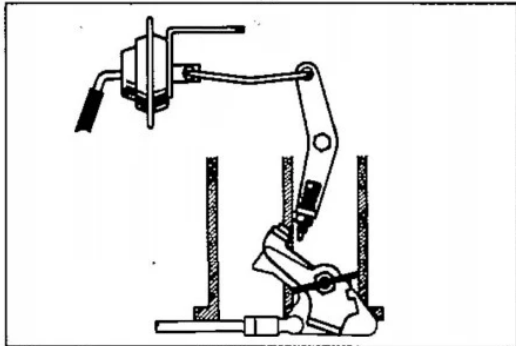
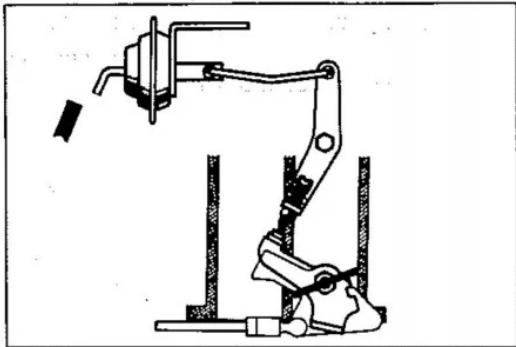

Fig. 2-51



FAST IDLE

1. Pull the choke button fully.
2. Open choke valve with a screwdriver and start the engine.

3. Set to the specified rpm by turning the fast idle adjusting screw.

Fast idle speed 1800 rpm

THROTTLE POSITIONER



1. Warm up the engine and check the idle speed.



2. Disconnect the TP diaphragm hose.
3. Open throttle valve slightly and release it. TP adjusting screw should hook on to the throttle valve lever.

Fig. 2-52

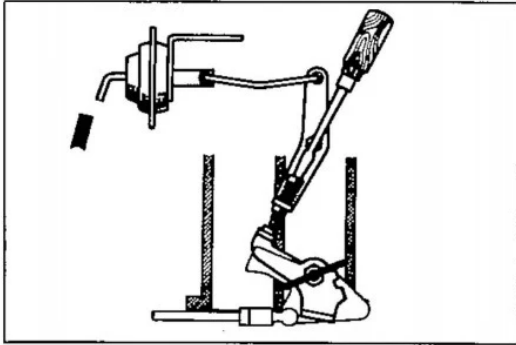

4. Check the engine speed.
If not at specified rpm, adjust by turning the TP adjusting screw.
TP setting speed 1200 rpm

Fig. 2-53

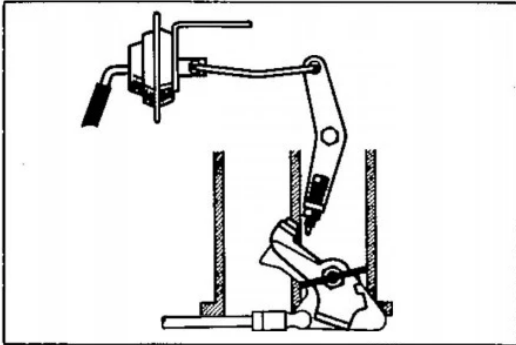

5. Reconnect the TP diaphragm hose.
6. Open throttle valve slightly and release it. Engine should return to idle speed.

Fig. 2-54



COMPRESSION PRESSURE



1. Warm up the engine.
2. Remove all spark plugs.
3. Disconnect the high tension cord from ignition coil to cut-off the secondary circuit.

Fig. 2-55

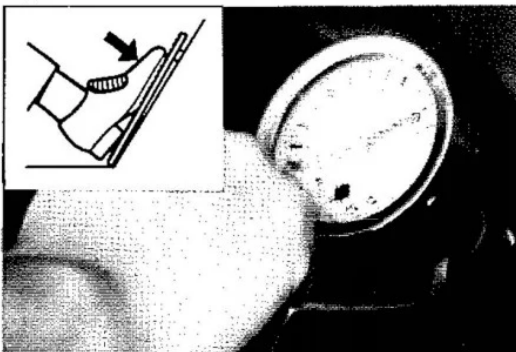

4. Insert a compression gauge into the spark plug hole, open the throttle valve fully, and measure the compression pressure while cranking the engine with starter motor.

Compression Pressure

10.5 kg/cm² (149.3 psi)

Limit

8.0 kg/cm² (113.8 psi)

(at 200 rpm)

[Faint, illegible text, likely bleed-through from the reverse side of the page]

MEMO

ENGINE SERVICE

| | Page |
|---|-------------|
| CYLINDER HEAD | 3- 4 |
| Includes: Cylinder Head, Valve and Spring Rocker Arm, Manifold | |
| DISASSEMBLY | 3- 4 |
| INSPECTION & REPAIR | 3- 7 |
| ASSEMBLY | 3-15 |
| TIMING GEAR | 3-19 |
| Includes: Valve Lifter, Camshaft Timing Gear | |
| DISASSEMBLY | 3-19 |
| INSPECTION & REPAIR | 3-22 |
| ASSEMBLY | 3-25 |
| CYLINDER BLOCK | 3-29 |
| Includes: Cylinder Block, Piston and Ring Crankshaft and Bearing Cylinder Boring, Camshaft Bearing Input Shaft Bearing Crankshaft Rear Oil Seal | |
| DISASSEMBLY | 3-29 |
| INSPECTION & REPAIR | 3-32 |
| ASSEMBLY | 3-40 |

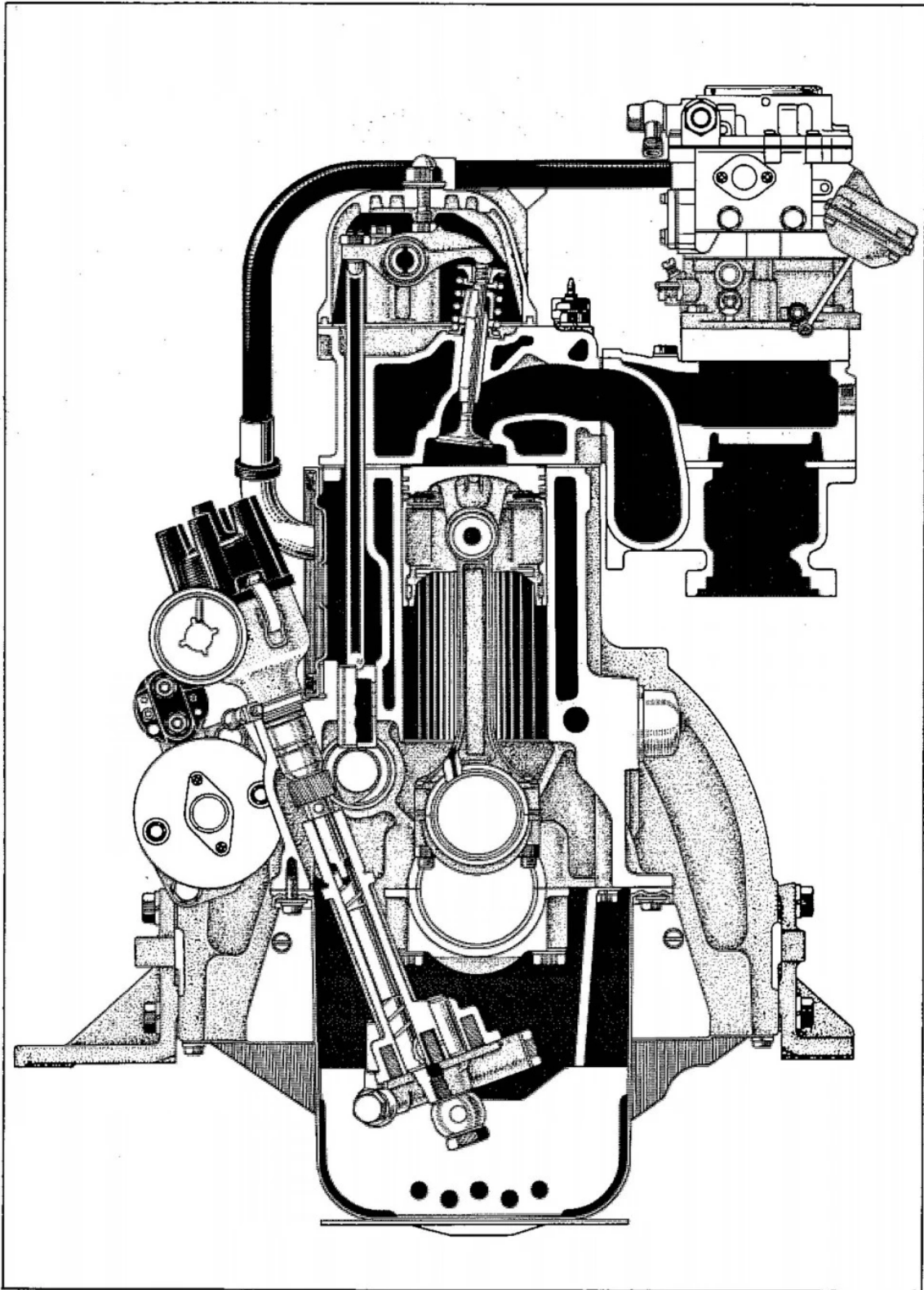

Fig. 3-1

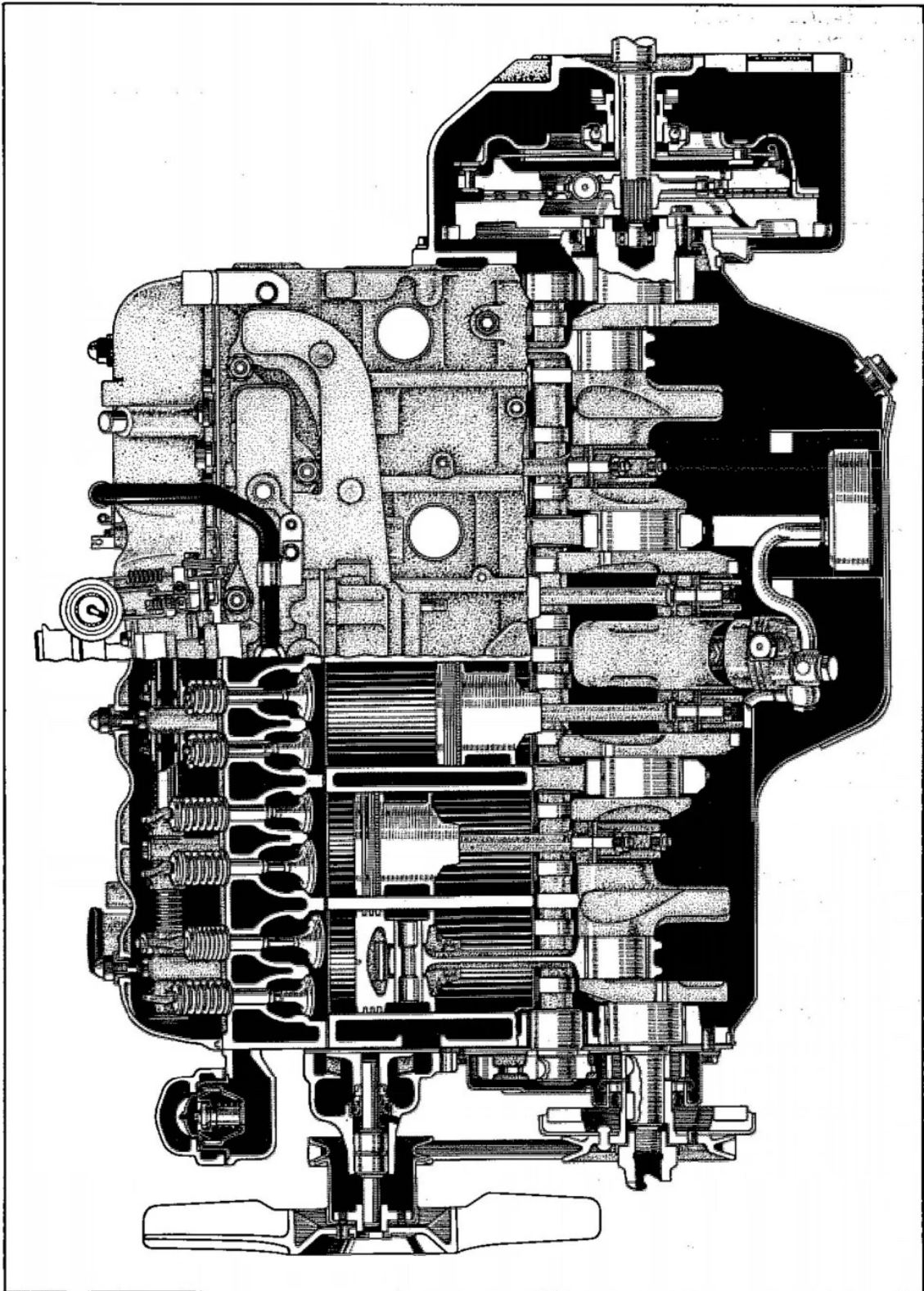

Fig. 3-2

CYLINDER HEAD DISASSEMBLY

Disassemble in numerical order.

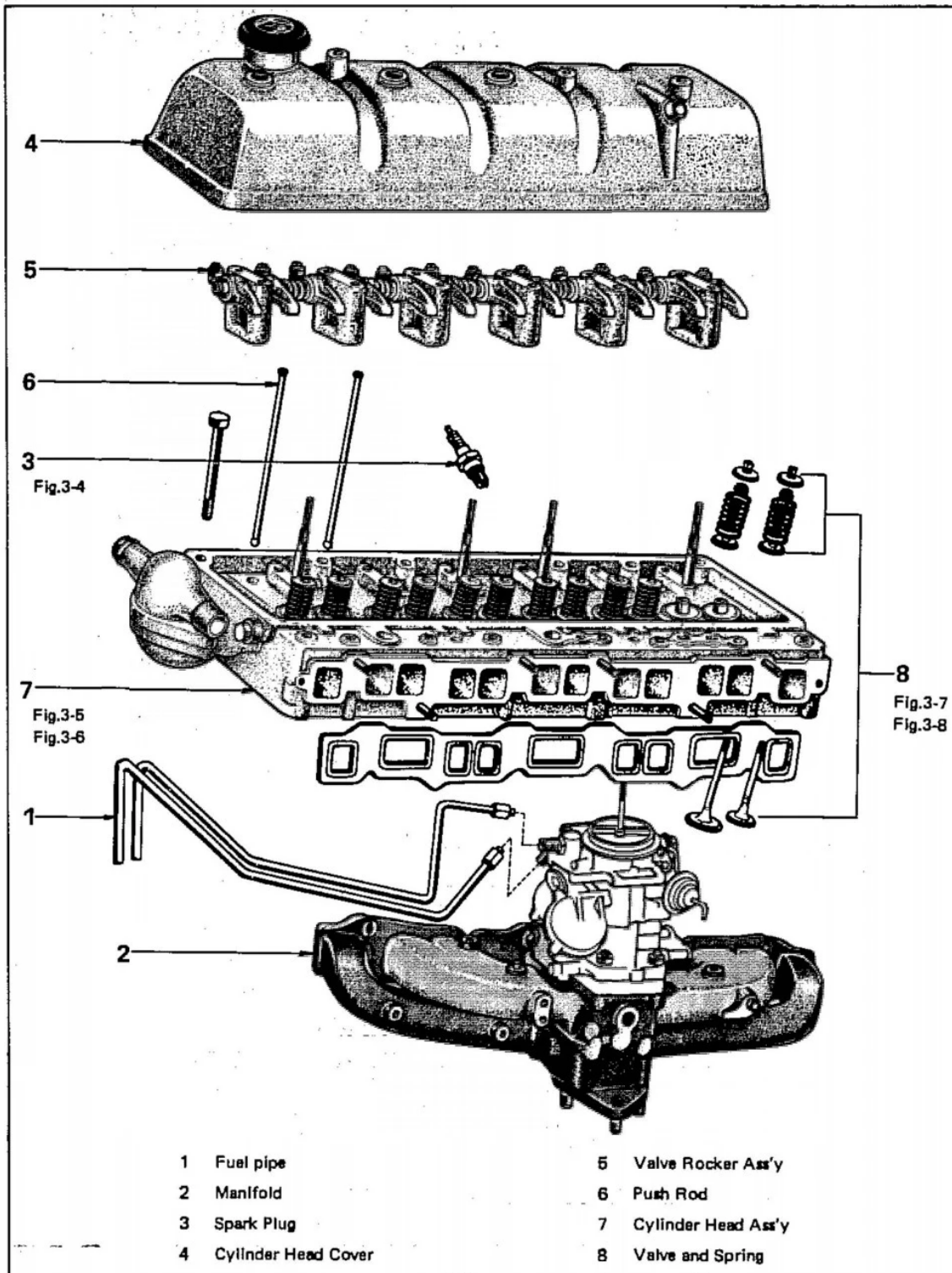
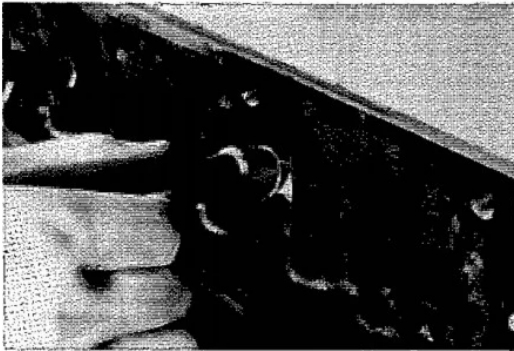

Fig. 3-3

Fig. 3-4



Remove carefully plug cords by pulling rubber boot.

Fig. 3-5

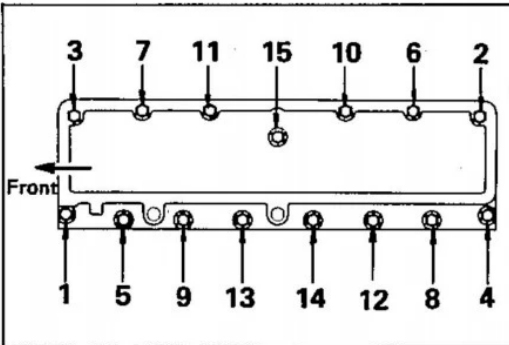

Gradually loosen cylinder head bolts in two to three stages in the sequence as shown.

Fig. 3-6

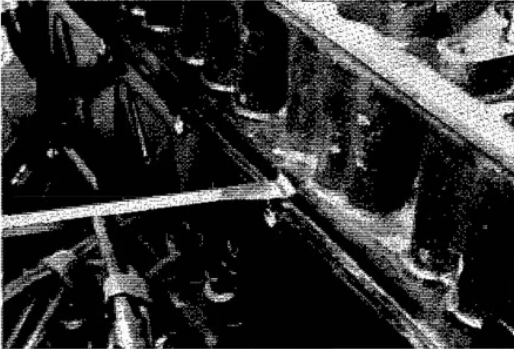

If difficult to lift up cylinder head, insert a screw driver into the notch and pry off as shown.

Fig. 3-7

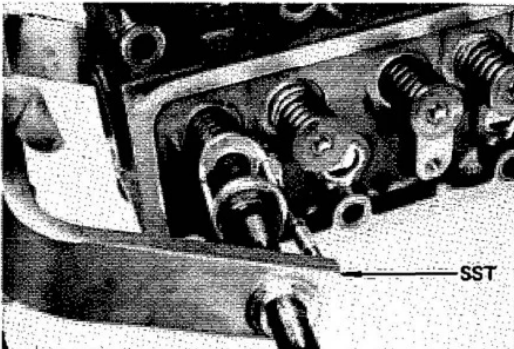

Compress the valve spring with SST [09202-43012].

Fig. 3-8

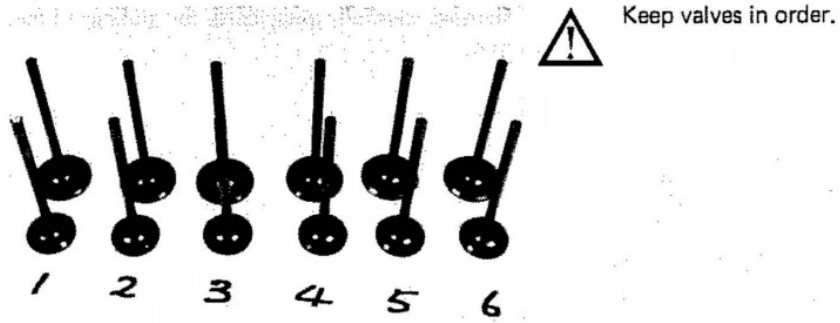
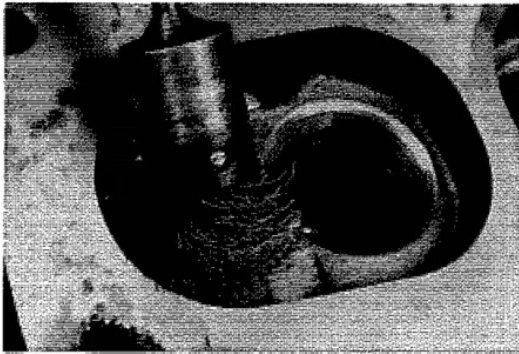

Fig. 3-9



INSPECTION & REPAIR

Cylinder Head

1. Clean combustion chamber and remove all gasket material from manifold and head surface.

Fig. 3-10

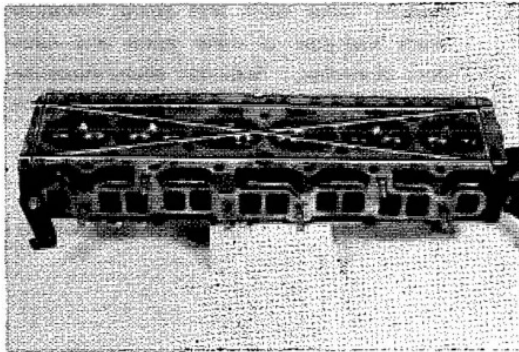

2. Using a precision straight edge, check head surface for flatness.

Fig. 3-11

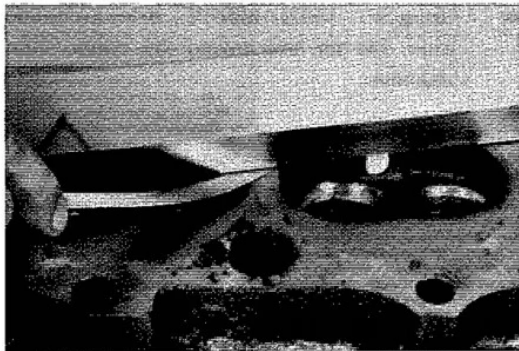

3. If warpage exceeds limit, correct by machining or replace head.

Head surface warpage limit
0.15 mm (0.0059 in)

Maximum refacing limit
0.2 mm
(0.008 in.)

Fig. 3-12



Valve, Guide and Seat

1. Clean valves.

Fig. 3-13

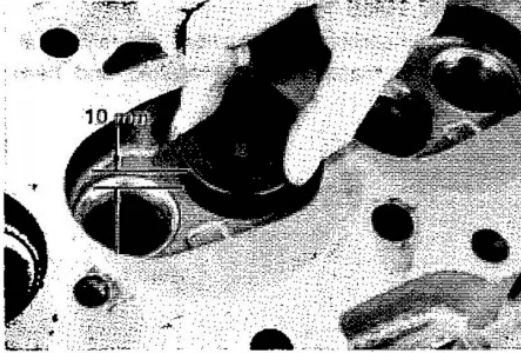

2. Quick-check valve stem and guide wear by inserting correct valve in guide and moving valve as shown. If movement exceeds 0.25 mm (0.01 in) for intake and exhaust, additional measurements are necessary.

Fig. 3-14

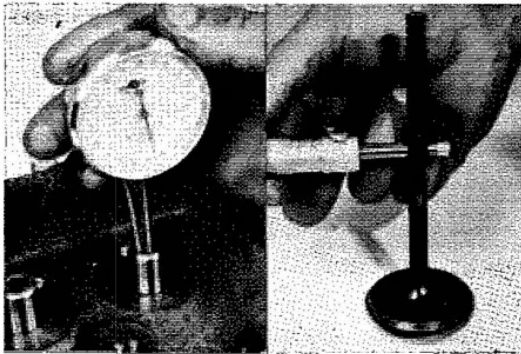

3. Measure valve stem and guide. Measure inside diameter of valve guide and valve stem diameter. Subtract stem measurement. Replace guide and valve if clearance exceeds limit.

Clearance limit

| | |
|---------|---------------------|
| Intake | 0.10 mm (0.0039 in) |
| Exhaust | 0.12 mm (0.0047 in) |

Fig. 3-15

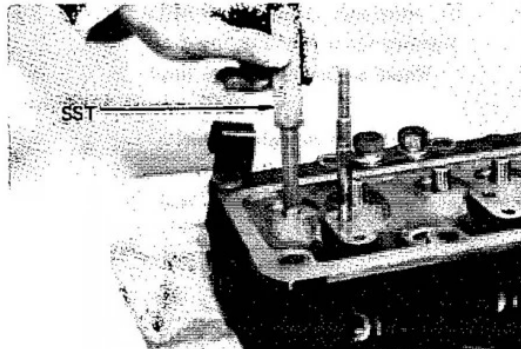

4. Using SST [09201-60011], drive out guide from the top end toward the combustion chamber.

Fig. 3-16

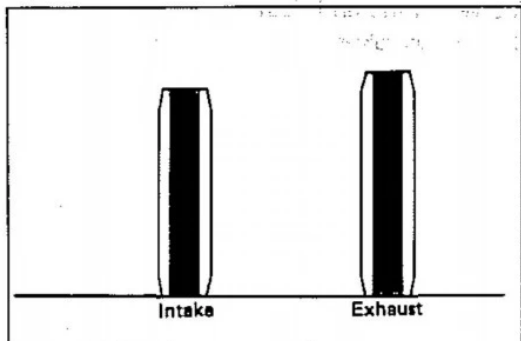

There are two types of valve guides and lengths are below.

| | |
|-----------|-----------------|
| Intake : | 54 mm (2.13 in) |
| Exhaust : | 59 mm (2.32 in) |

Fig. 3-17

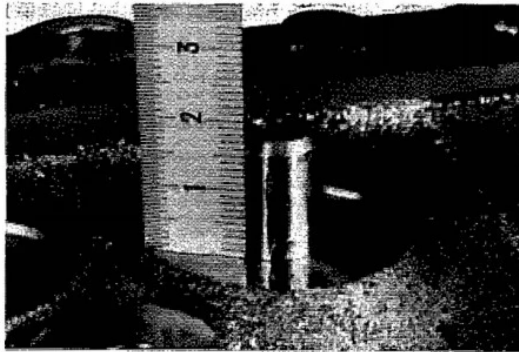

Fig. 3-18

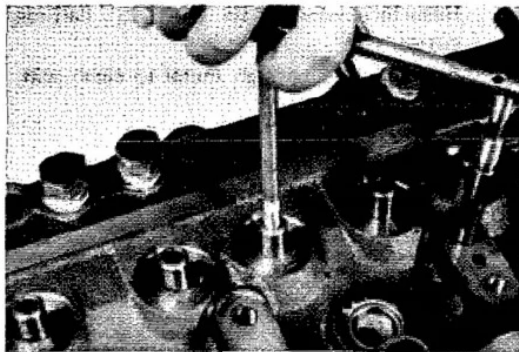

Fig. 3-19

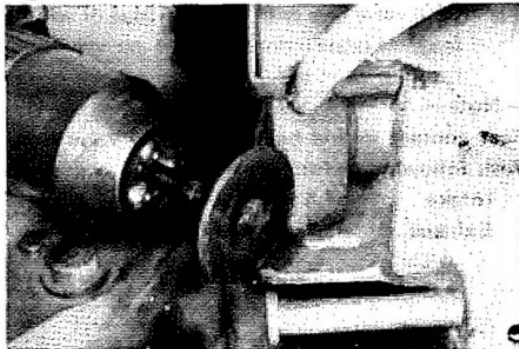
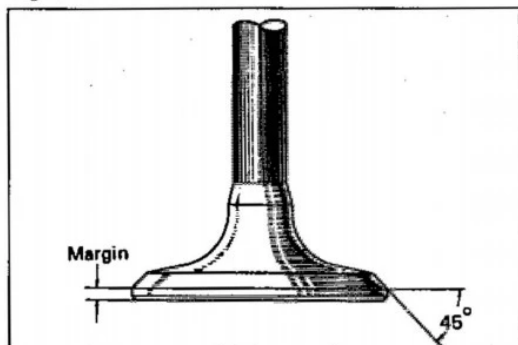

Fig. 3-20



5. Using SST [09201-60011], drive in new guide until its end projects from cylinder head the distance noted below.

Projection distance

17 mm (0.67 in)

6. Using a sharp 8 mm reamer, ream guide to obtain specified clearance.

Intake

0.03-0.06 mm (0.0012-0.0024 in)

Exhaust

0.04-0.07 mm (0.0016-0.0028 in)

7. Grind all valves. Remove only enough metal to remove pits and carbon.

Valve face angle : 45°

8. Check margin.
If valve head margin is less than specification, replace valve.

Margin limit

Intake 0.8 mm (0.031 in)

Exhaust 1.0 mm (0.039 in)

Fig. 3-21

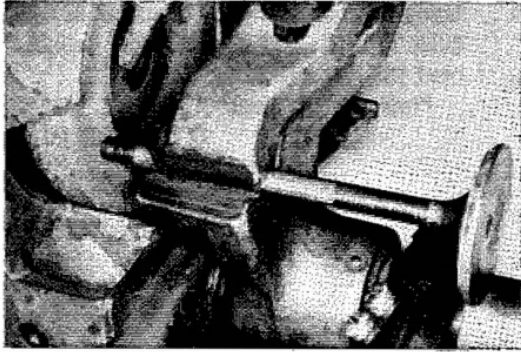

Fig. 3-22

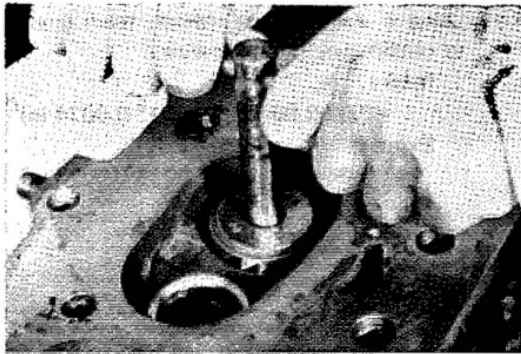

Fig. 3-23

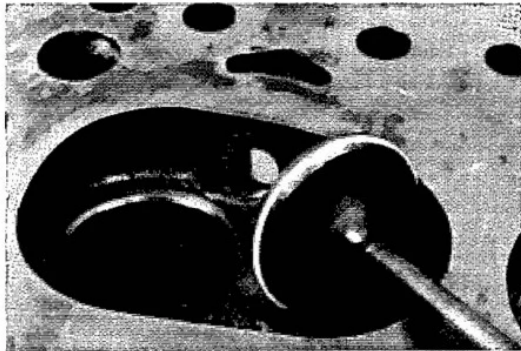
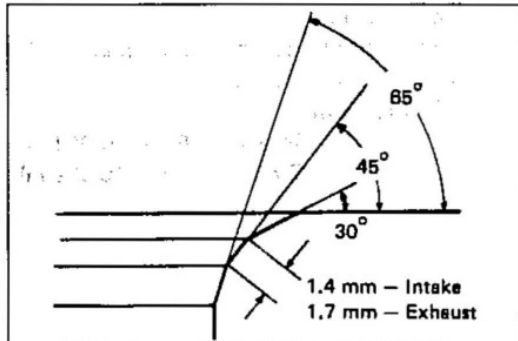

Fig. 3-24



9. If valve stem tip has been worn by rocker arm, resurface with valve grinder. Do not grind more than 0.5 mm (0.02 in).

10. Resurface valve seats with 45° carbide cutter. Remove only enough metal to clean seat.

11. Coat valve face with prussion blue or white lead. Locate contact point on valve by rotating valve against seat.

– Note –

Seat contact should be in middle of valve face with following width:

| | |
|---------|-------------------|
| Intake | 1.4 mm (0.055 in) |
| Exhaust | 1.7 mm (0.067 in) |

12. Correct seat position.
To correct seating that is too high, use 30° and 45° cutters. If seating is too low, use 65° and 45° cutters.

Fig. 3-25

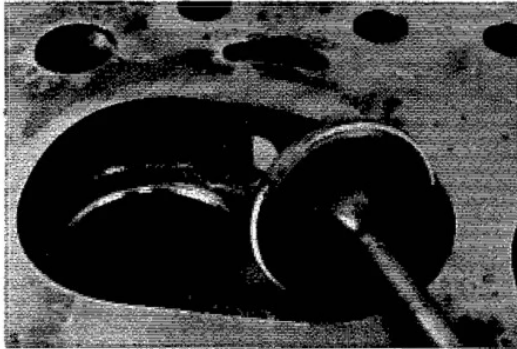

Fig. 3-26

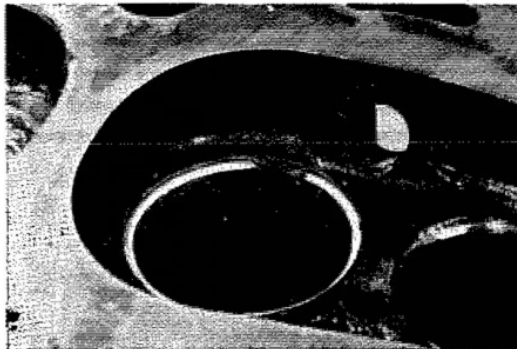

Fig. 3-27

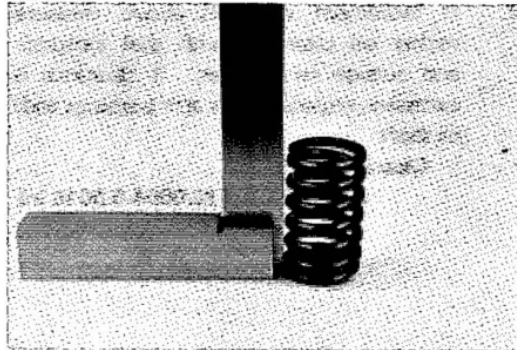
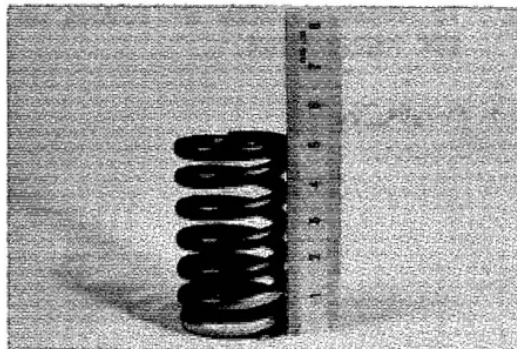

Fig. 3-28



13. Check valve concentricity.
Lightly coat seat with prussian blue. Install valve and rotate. If blue appears 360° around face, valve stem and face are concentric. If not, replace valve.

14. Check seat/guide concentricity.
Apply a light coat of prussian blue on valve face. Install and rotate valve. If blue appears 360° around valve seat, guide and seat are concentric. If not, recut seat.



Valve Spring

1. Check squareness of valve springs with steel square. If spring is out of square more than limit, replace.

**Limit (intake and exhaust)
2 mm (0.079 in)**



2. Measure free height of all springs. Replace any spring that is out of specification.

Free height 51.5 mm (2.028 in)

Fig. 3-29

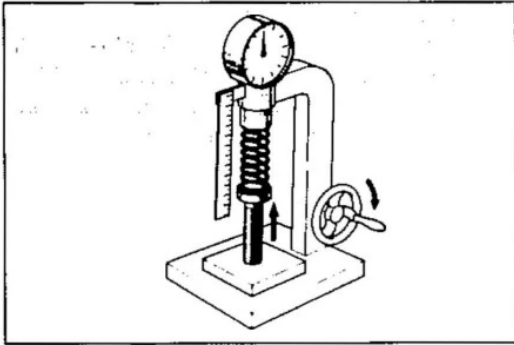

3. Using a spring tester, measure tension of each spring at the specified installed height. Replace any spring that does not meet specification.

Limit 27 kg (59.5 lb)
Standard 32.5 kg (71.6 lb)

Fig. 3-30

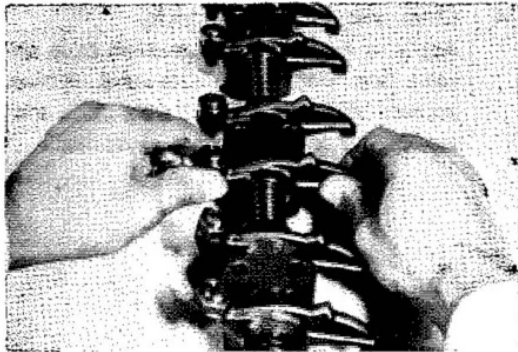

Rocker Arm and Shaft

1. Check rocker arm to shaft clearance by moving rocker arm as shown. Little or no movement should be indicated. If movement is felt, disassemble and inspect.

Fig. 3-31

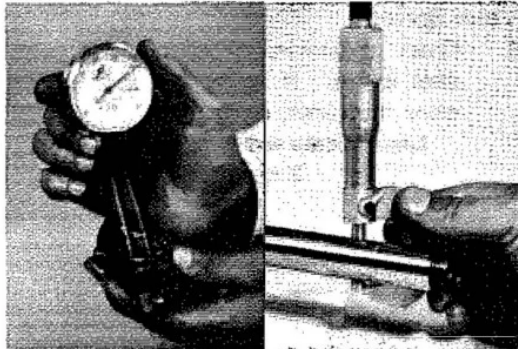

2. If movement was felt above, measure rocker oil clearance with dial indicator and outside micrometer. If clearance is excessive, replace rocker arm bushings and/or shaft.

Clearance
 0.01-0.04 mm (0.0004-0.0016 in)

Fig. 3-32

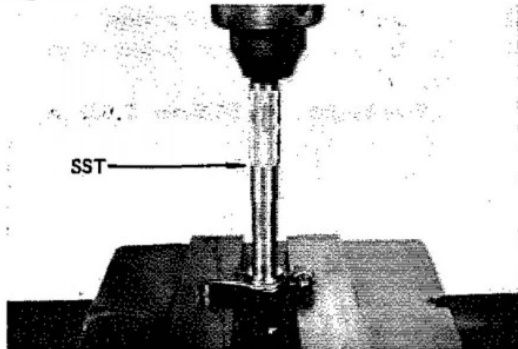

3. To remove the rocker arm bushing, use SST [09222-30010].

Fig. 3-33

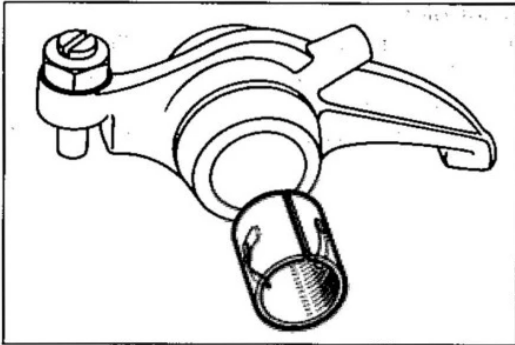

4. When assembling bushing, align oil hole with that of the rocker arm. After assembling, ream bushing to obtain specified oil clearance.

Fig. 3-34

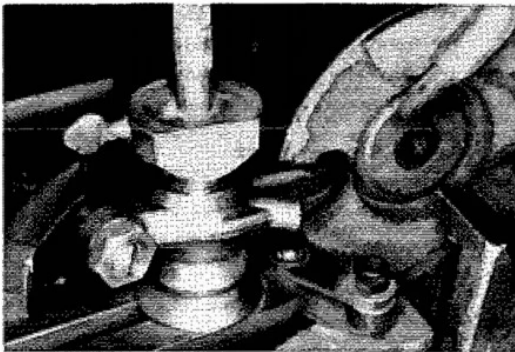

5. If the valve rocker arm surface contacting the valve stem end is worn excessively, replace the rocker arm. If only a light ridged wear, correct with valve refacer and oil stone.

Fig. 3-35

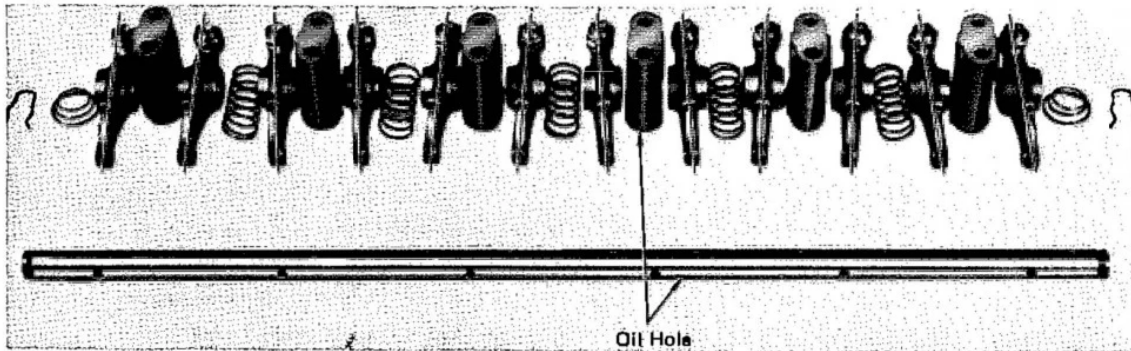

6. Assemble rockers and shaft. There are two types of rocker arms and rocker supports. Boss of rocker supports should be pointed front. Oil hole is provided on fourth support. These should be assembled as shown.

Fig. 3-36

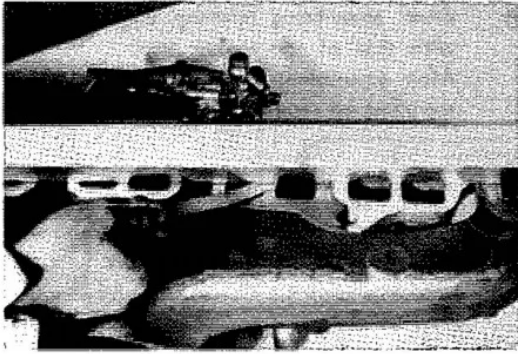
**Manifolds**

1. Inspect surfaces contacting cylinder head for warpage, and replace if warped over the limit.

Warpage limit 2 mm (0.08 in)

Fig. 3-37

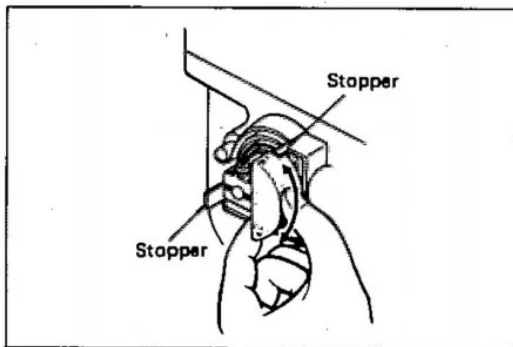

2. When the heat control valve shaft is turned by hand, the valve should move smoothly to the stopper, and when released, it should return to the other stopper.

ASSEMBLY

Assemble in numerical order.

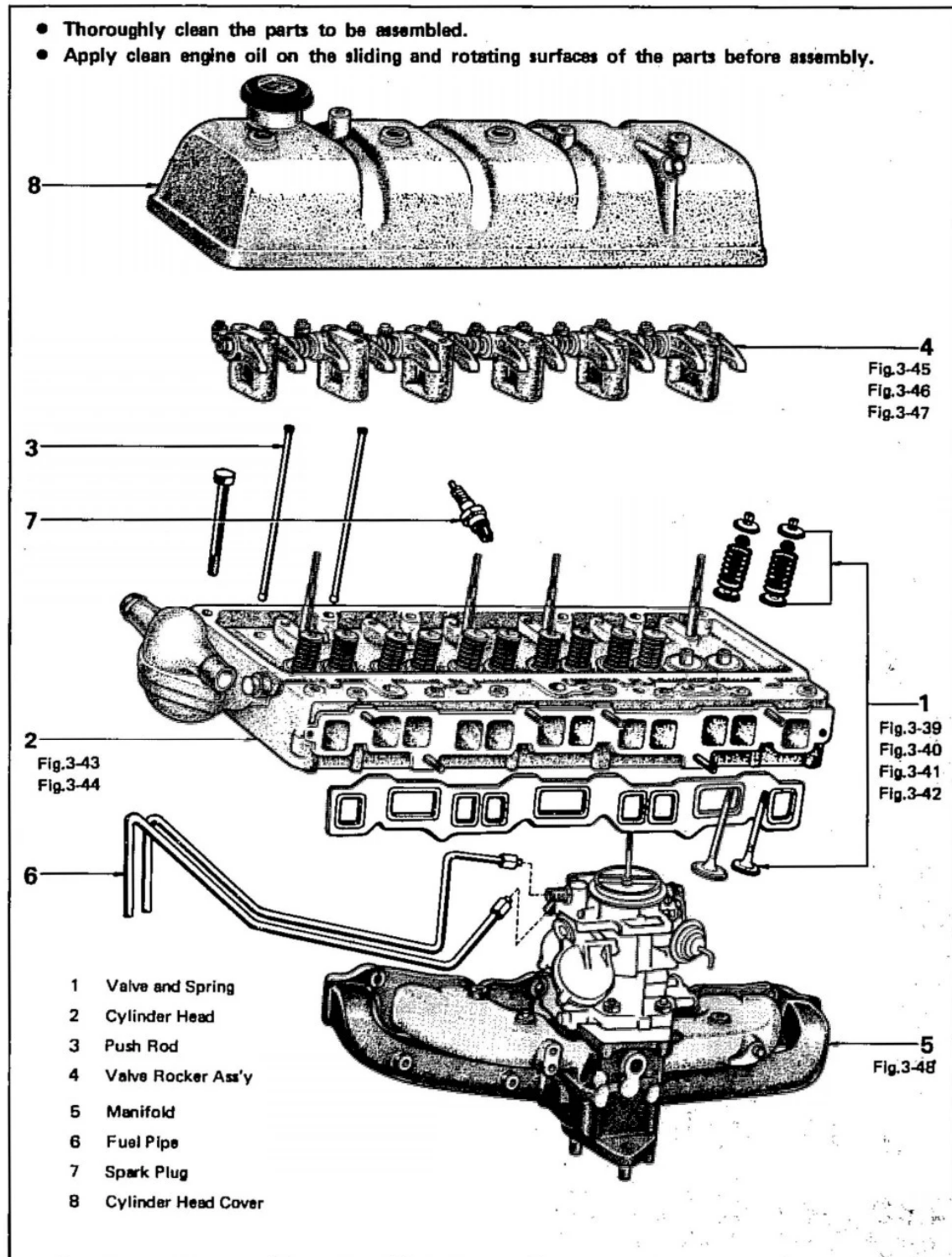
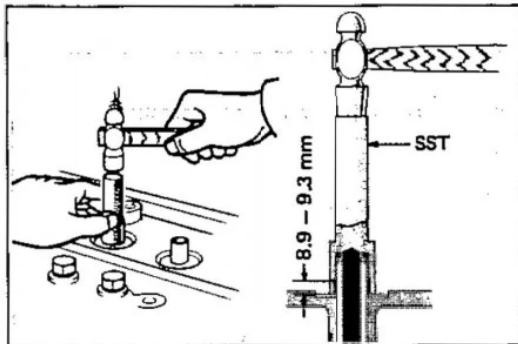

Fig. 3-38

Fig. 3-39



Assemble spring seat and drive in the oil seal with SST [09201-31010].

Drive in distance: 8.9 – 9.3 mm
(0.35 – 0.37 in.)

– Note –

1. A new oil seal should be used whenever the valve is disassembled.
2. Coat the oil seal lip with engine oil.

Fig. 3-40

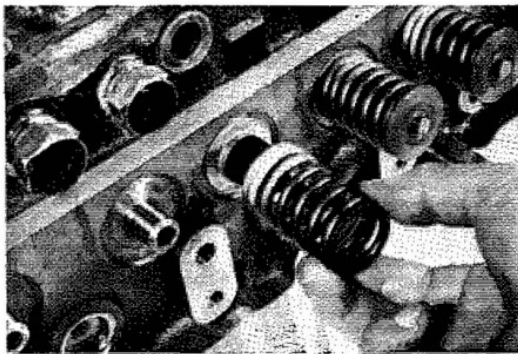

Install valve spring in direction as shown. Painted surface should be pointed toward the cylinder head.

Fig. 3-41

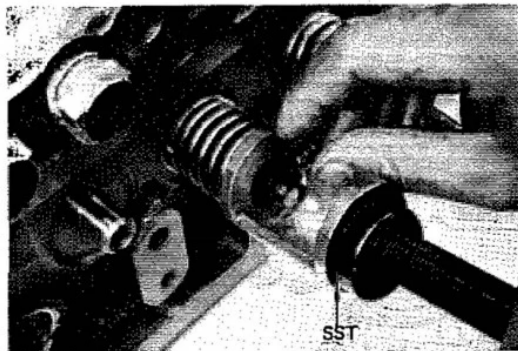

Compress the valve spring with SST [09202-43012] and install retainer locks.

Fig. 3-42

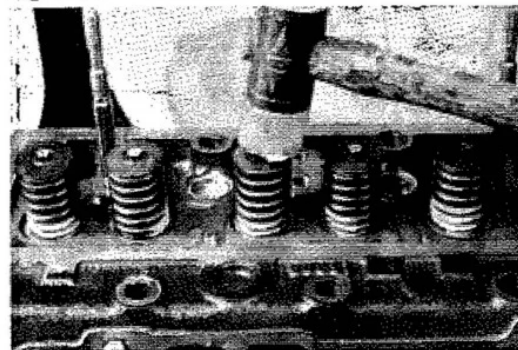

After assembling valve spring, tap stem lightly to assure proper fit.

Fig. 3-43

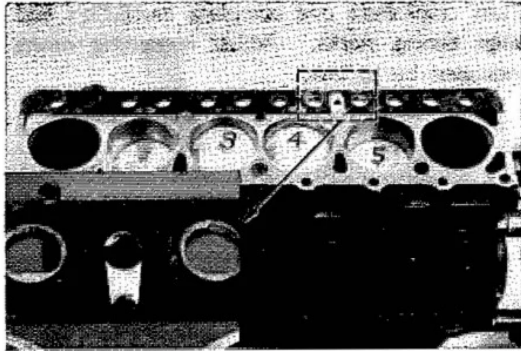

Put head gasket on cylinder block, mating oil hole as shown.

Fig. 3-44

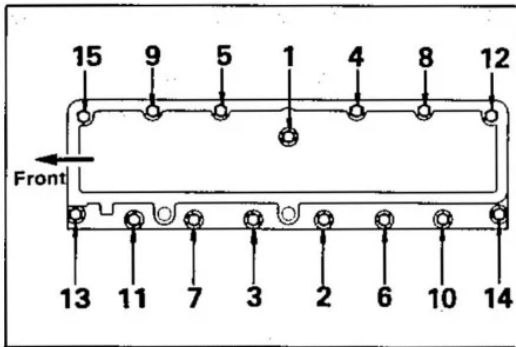

Gradually tighten cylinder head bolts in two to three stages in the sequence as shown.

Torque **11.5-13.5 kg-m**
 (83-98 ft-lb)

Fig. 3-45

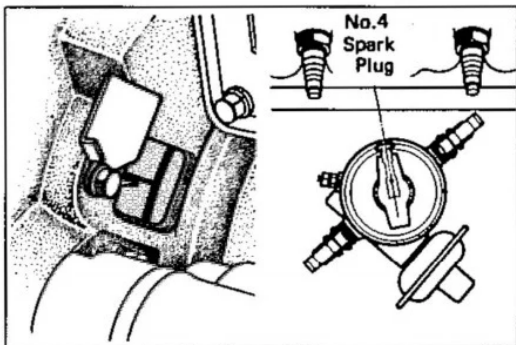

Set No. 1 cylinder to TDC/compression. Align Timing mark (groove) with pointer. The distributor rotor should face toward the position as shown.

Fig. 3-46

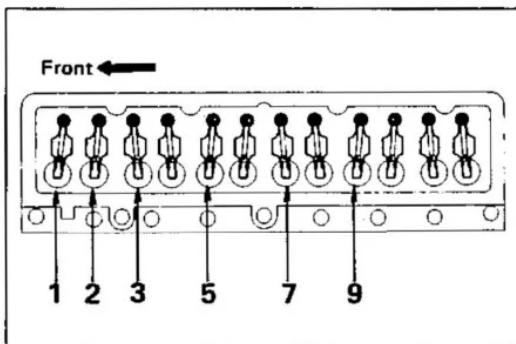

Adjust valve clearances indicated by arrows only.

Clearance (Hot)
Intake **0.20 mm (0.008 in)**
Exhaust **0.35 mm (0.014 in)**

Fig. 3-47

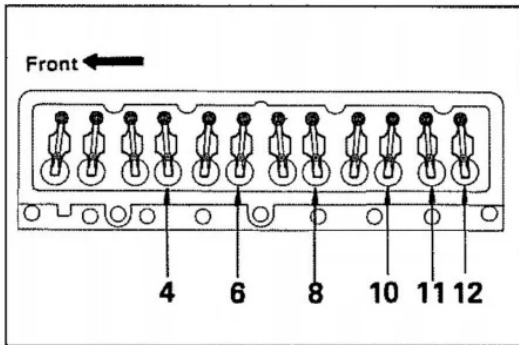

Turn crankshaft one complete revolution and align timing marks. Adjust remaining valves indicated by arrows.

Fig. 3-48

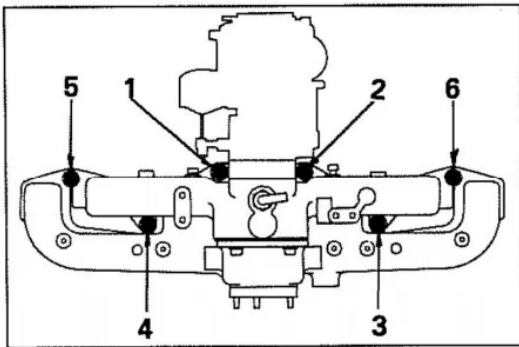

Tighten the manifold securing nuts in the sequence as shown.

Torque 3.9-5.1 kg-m (28-37 ft-lb)
 5.0-7.0 kg-m (36.2-50.6 ft-lb)
 For Calif. only.

TIMING GEAR DISASSEMBLY

Disassemble in numerical order.

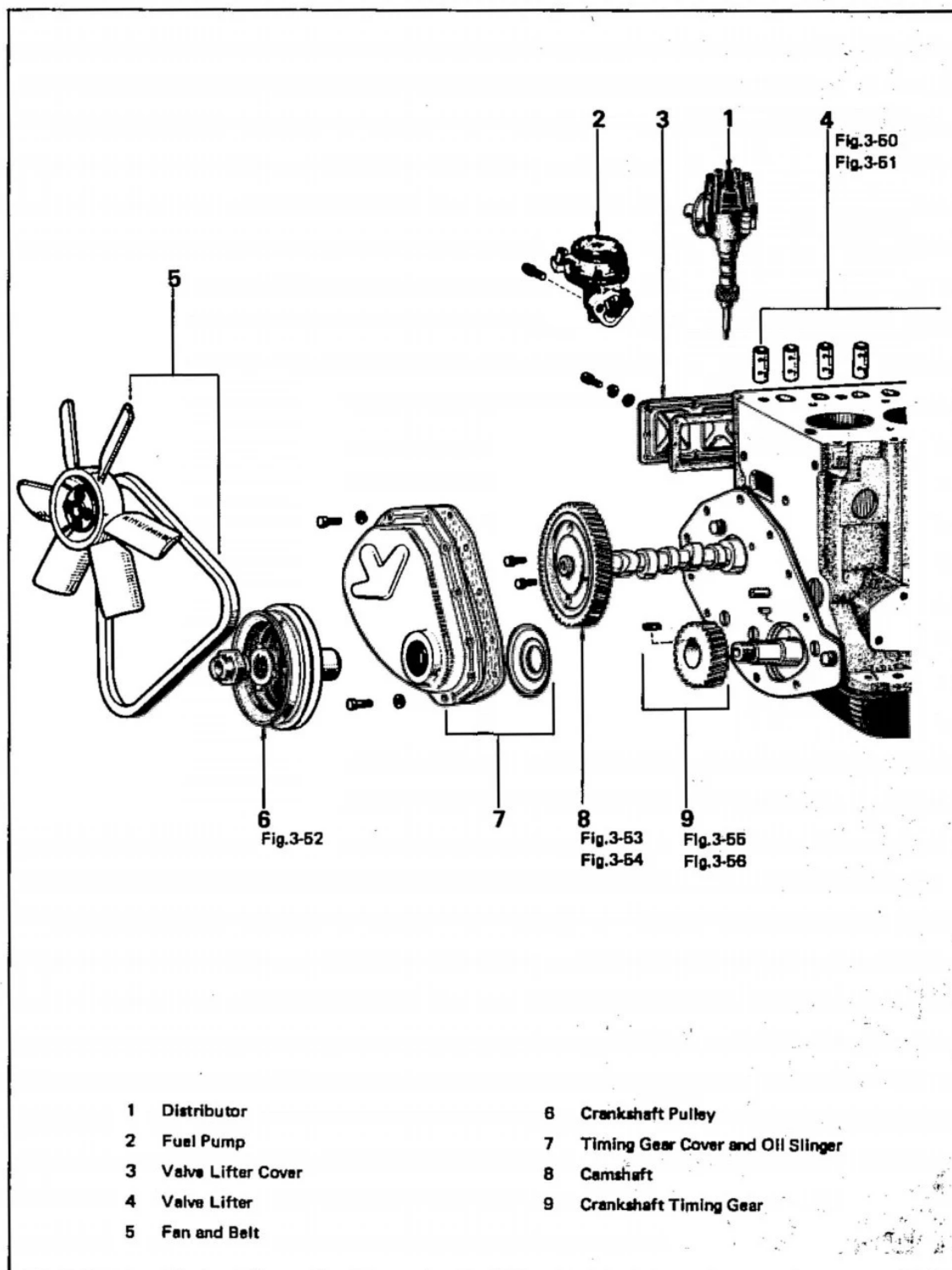
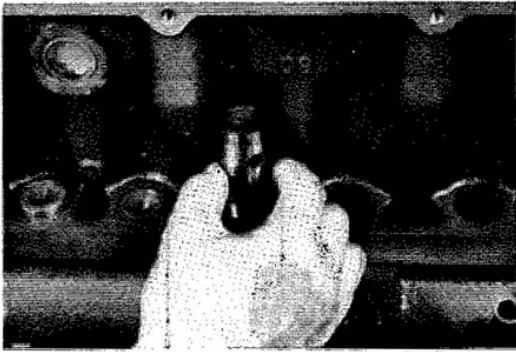

Fig. 3-49

Fig. 3-50



Pull out valve lifter.
Turn crankshaft to lift up lifters.

Fig. 3-51

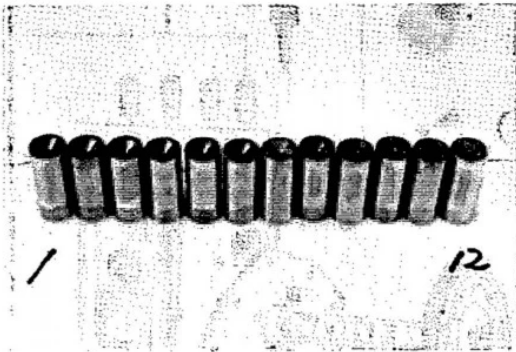

Keep lifters in order.

Fig. 3-52

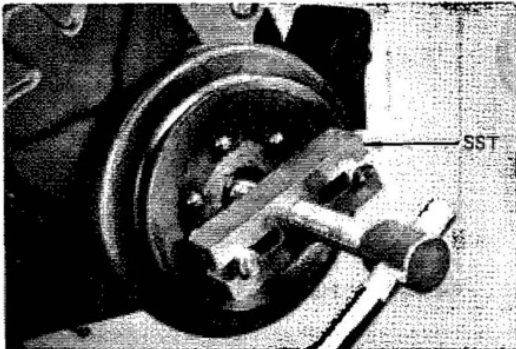

Using SST [09213-60016], pull out crankshaft pulley.

Fig. 3-53

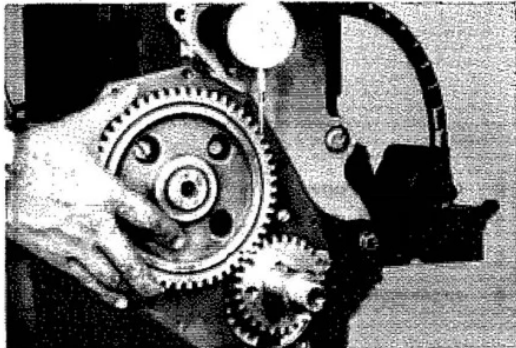

Measure Timing gear backlash. If it exceeds limit, replace both cam and crank gears.

Backlash limit 0.2 mm (0.008 in)

Standard

0.05-0.13 mm (0.0020-0.0051 in)

Fig. 3-54

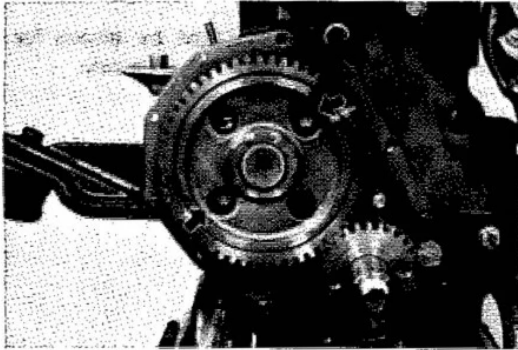

Remove two bolts indicated by arrows and slide out camshaft.

– Note –

Take care not to damage camshaft bearing.

Fig. 3-55

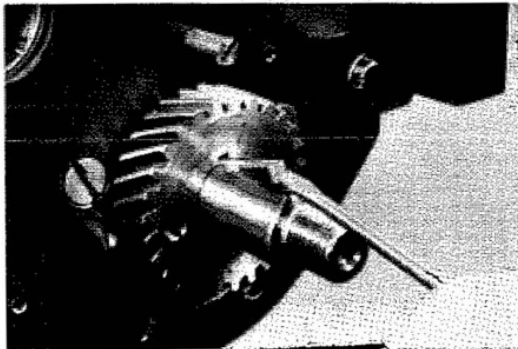

Remove pulley key from crankshaft before removing crankshaft gear.

Fig. 3-56

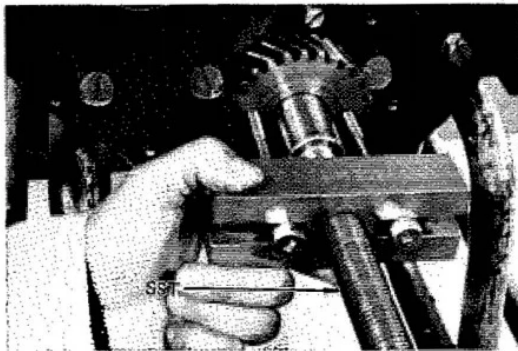

Using SST [09213-60016], pull out crankshaft gear.

Fig. 3-57

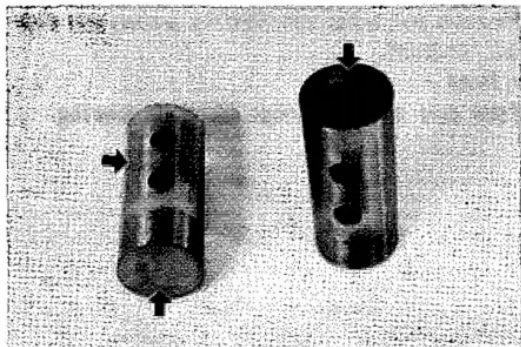
**INSPECTION & REPAIR****Valve Lifter**

Inspect lifter surfaces indicated by arrows for wear and pitting, and, replace if necessary.

Fig. 3-58

**Crankshaft Front Oil Seal**

Inspect oil seal lip for wear and deformation. Replace oil seal using SST [09515-35010].

Fig. 3-59

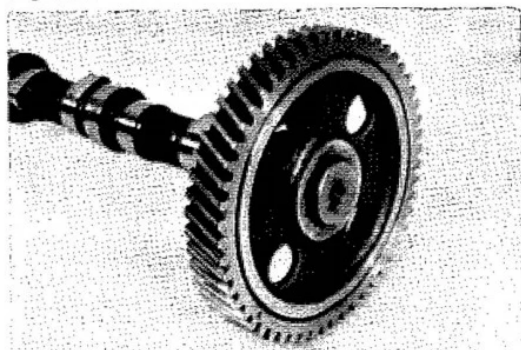
**Timing Gear**

Inspect gear for cracks, wear and chipped teeth. If damaged, replace both timing gears.

Fig. 3-60

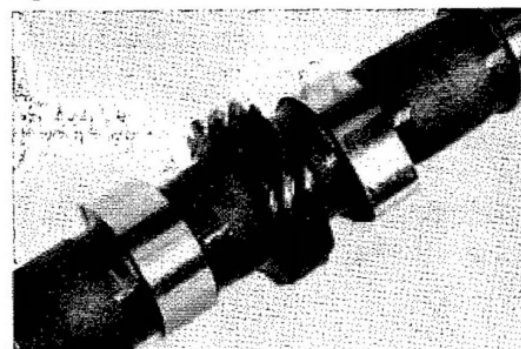
**Camshaft**

1. Inspect distributor drive gear. If damaged, replace, and also inspect distributor gear.

Fig. 3-61

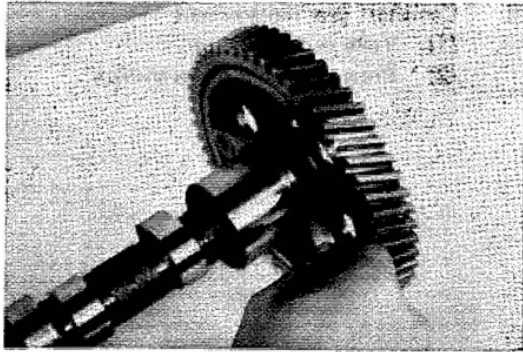

2. Measure thrust clearance. If it exceeds limit, replace thrust plate.

Thrust clearance limit

0.2 mm (0.008 in)

Standard

0.09-0.15 mm (0.0035-0.0059 in)

Fig. 3-62

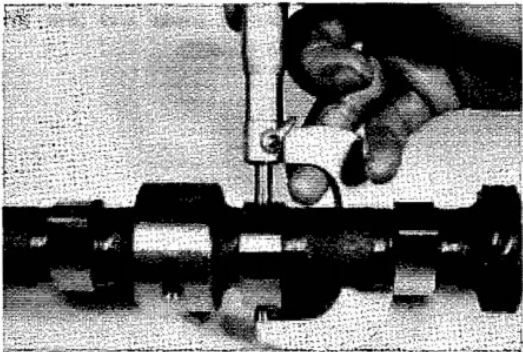

3. Measure cam lobe height. If wear exceeds limit, replace camshaft.

Height limit Intake

38.0 mm (1.496 in)

Exhaust

37.9 mm (1.492 in)

Fig. 3-63

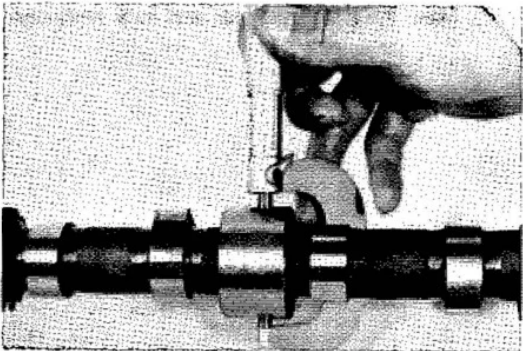

4. Measure camshaft journal. If wear is excessive, camshaft should be reground or replaced.

Journal diameter (STD)

No.1 47.955-47.975mm(1.8880-1.8888 in)

No.2 46.455-46.475mm(1.8289-1.8297 in)

No.3 44.955-44.975mm(1.7699-1.7707 in)

No.4 43.455-43.475mm(1.7108-1.7116 in)

For u/s bearing, refer to page 3-38.

Fig. 3-64

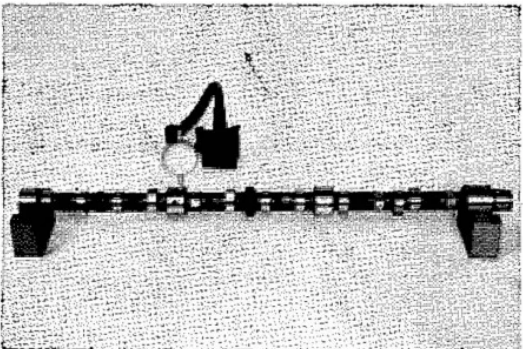

5. Measure runout. If it exceeds limit, replace camshaft.

Runout limit 0.15 mm (0.0059 in)

Fig. 3-65

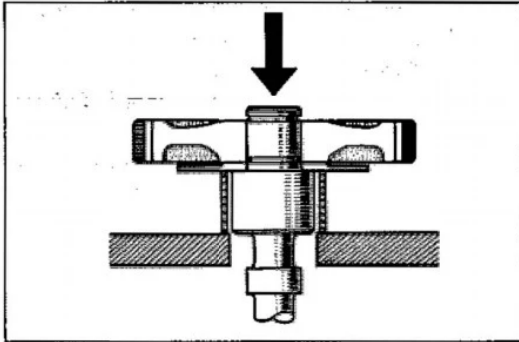

6. Camshaft gear replacement
 (1) Take out snap ring.
 (2) Press out camshaft as shown.

Fig. 3-66

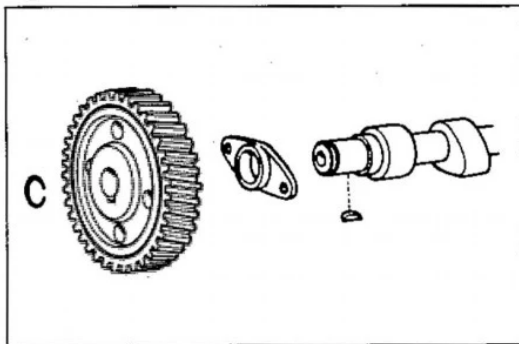

- (3) Assemble thrust plate and gear in direction as shown.

Fig. 3-67

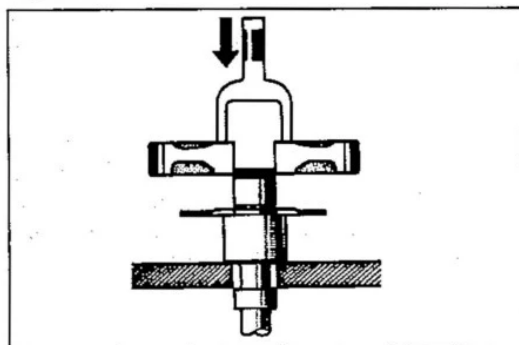

- (4) Press in cam gear and lock with new snap ring.

ASSEMBLY

Assemble in numerical order.

- Thoroughly clean the parts to be assembled.
- Apply clean engine oil on the sliding and rotating surfaces of the parts before assembly.

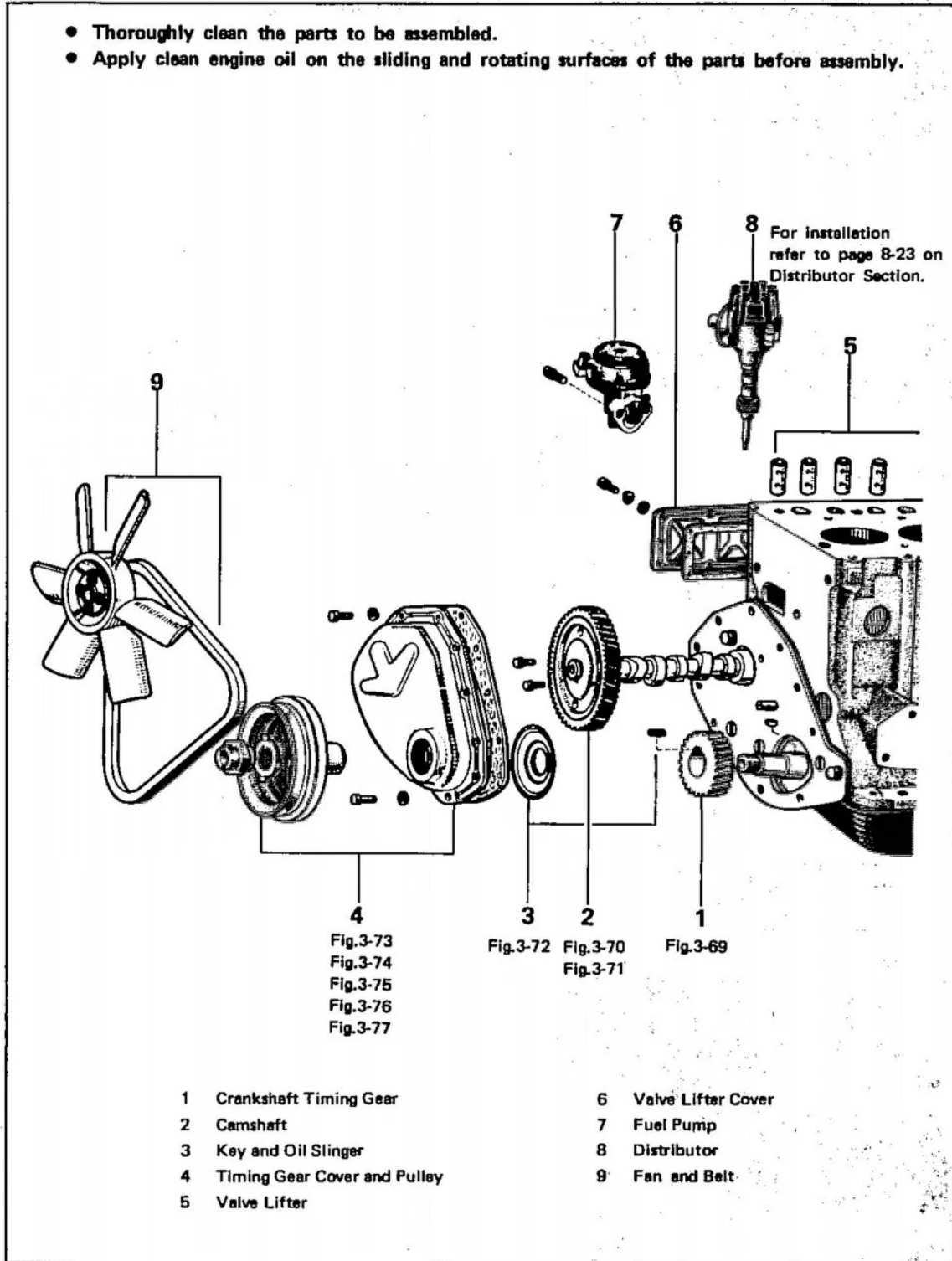
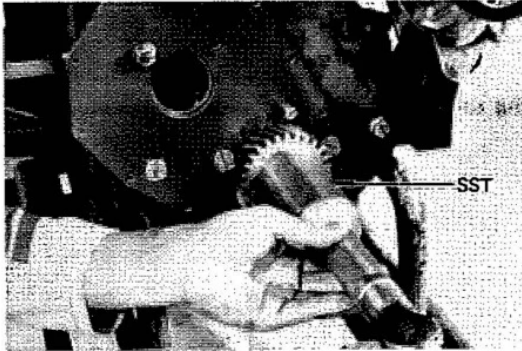

Fig. 3-68

Fig. 3-69



Use SST [09214-60010].
Timing mark stamped on gear should be faced toward front.

Fig. 3-70

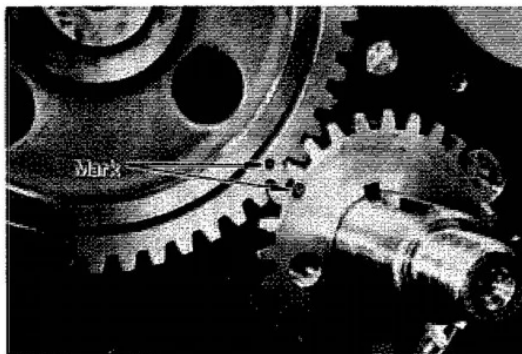

Carefully insert camshaft and mesh gears matching timing marks. Bolt on thrust plate and check gear backlash.

Torque 1-1.6 kg-m (7-12 ft-lb)
Backlash 0.05-0.13 mm (0.0020-0.0051 in)

– Note –
At this time, No.6 cylinder is at TDC/compression.

Fig. 3-71

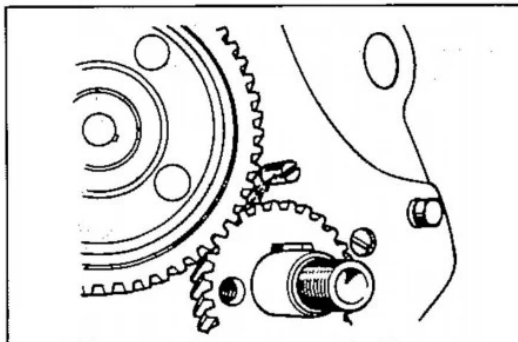

If oil nozzle was removed, screw in and stake the plate at two places.
Oil hole should be faced to position shown.

Fig. 3-72

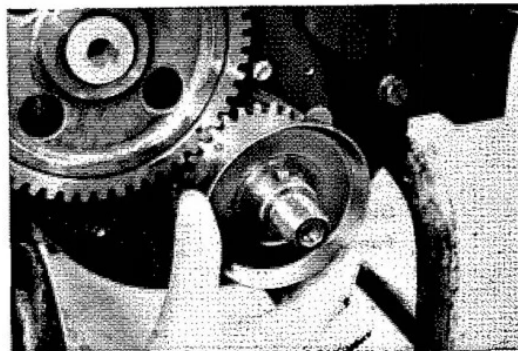

Fit pulley key to crankshaft and install oil slinger in direction as shown.

Fig. 3-73

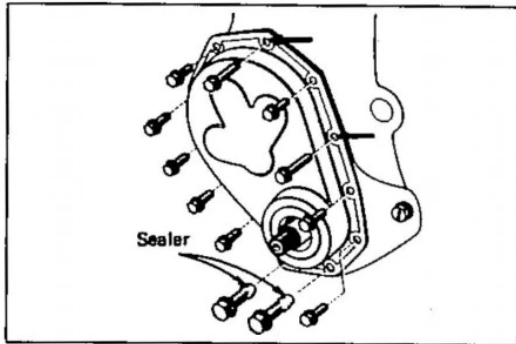

Install timing gear cover and pulley as follows:

Bolts locations

Bolt length – Longer bolt

Apply liquid sealer onto lower two bolts threads.

Fig. 3-74

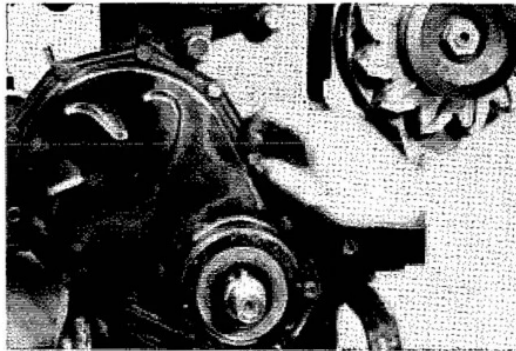

(1) Screw in all bolts to finger tightness.

Fig. 3-75

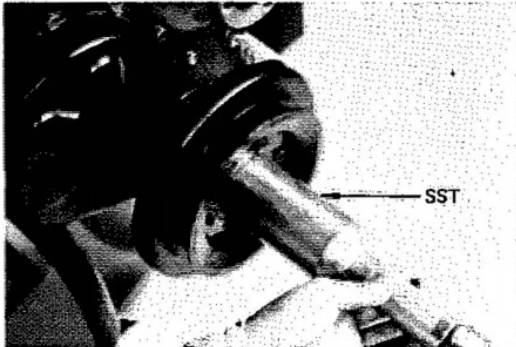

(2) Using SST [09214-60010], drive in pulley to locate the timing gear cover correctly.

Fig. 3-76

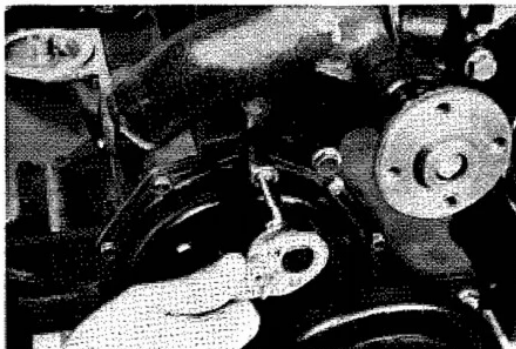

(3) After installing the pulley, tighten cover bolts.

Fig. 3-77

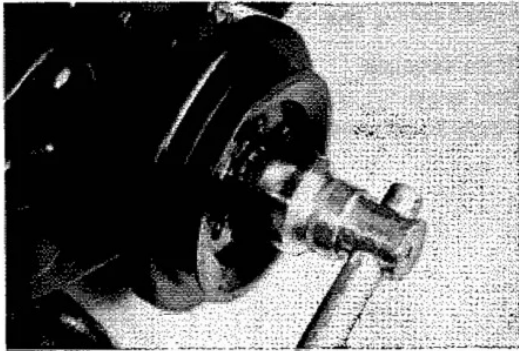

- (4) Tighten claw nut and lock with lock plate.
Torque **16-20 kg-m**
 (116-145 ft-lb)

CYLINDER BLOCK DISASSEMBLY

Disassemble in numerical order

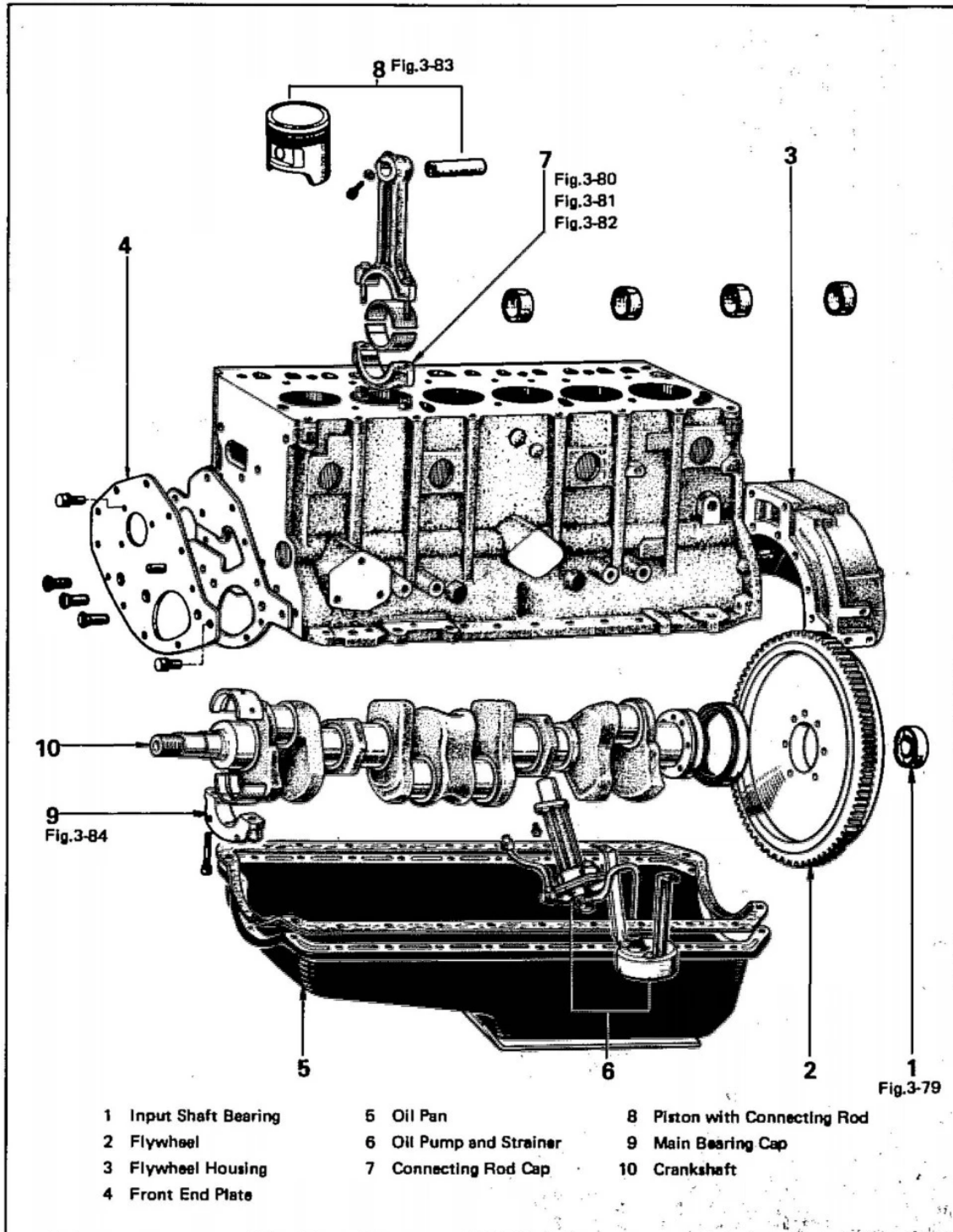
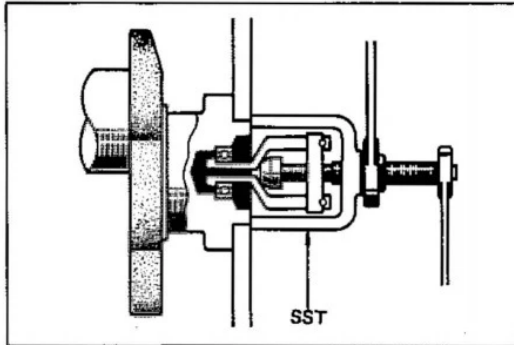

Fig. 3-78

Fig. 3-79



Using SST [09303-55010], remove input shaft bearing.

Fig. 3-80



Measure connecting rod thrust clearance. If it exceeds limit, replace connecting rod.

Thrust clearance limit

0.3 mm (0.012 in)

Standard

0.11-0.23 mm (0.0043-0.0091 in)

Fig. 3-81



Mark connecting rod and cap for correct reassembly.

Fig. 3-82

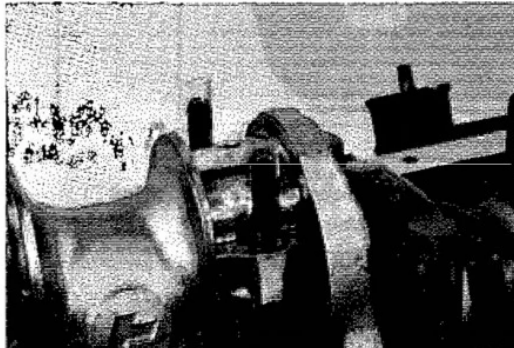

Cover rod bolts with a short length of hose to protect crankshaft from damage.

Fig. 3-83

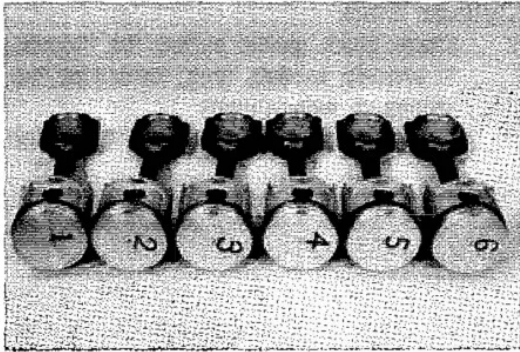

Keep connecting rod and bearing in order.

Fig. 3-84

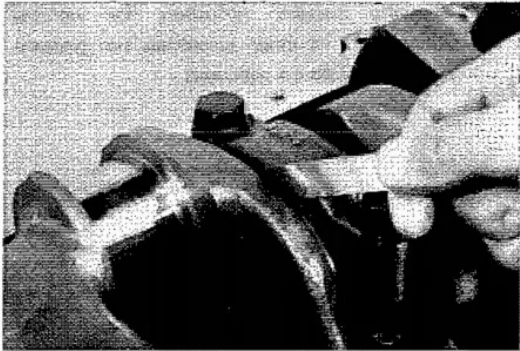

Measure crankshaft thrust clearance. If it exceeds limit, replace bearing as a set.

Thrust clearance limit

0.3 mm (0.012 in)

Standard

0.06-0.16 mm (0.0024-0.0063 in)

Fig. 3-85

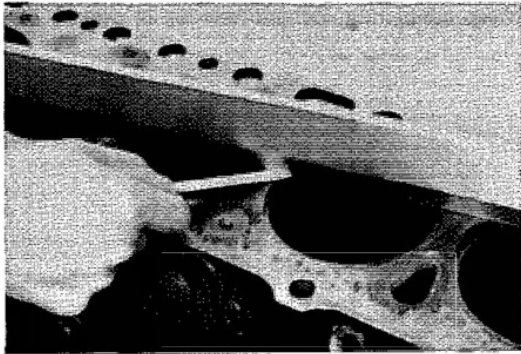

Fig. 3-86

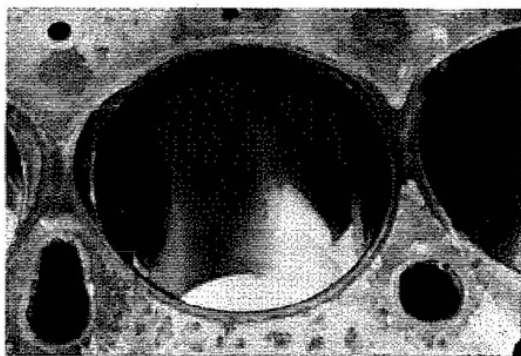

Fig. 3-87

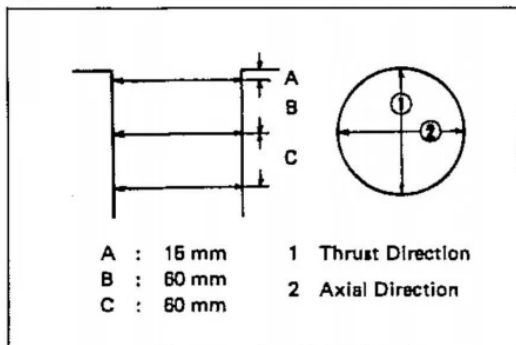

Fig. 3-88

**INSPECTION & REPAIR****Cylinder Block**

1. Check block gasket surface for flatness. If warpage exceeds limit, correct by machining or replace block.

Warpage limit **0.15 mm (0.0059 in)**



2. Visually inspect cylinders for vertical scratches. If deep scratches are present, cylinder must be rebored.

3. Measure cylinders at the top, middle, and bottom as shown. If cylinder exceeds specification, it must be rebored.

Wear limit **0.2 mm (0.008 in)**

Standard bore **94.00-94.05 mm
(3.7008-3.7027 in)**

Piston and Ring

1. Check pin fit by trying to rock piston at right angle to pin. If any movement is felt, piston with pin must be replaced.

Fig. 3-89

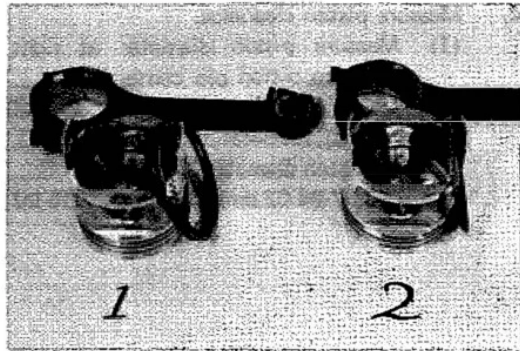

After disassembling, keep piston, pin, ring and rod in order.

Fig. 3-90

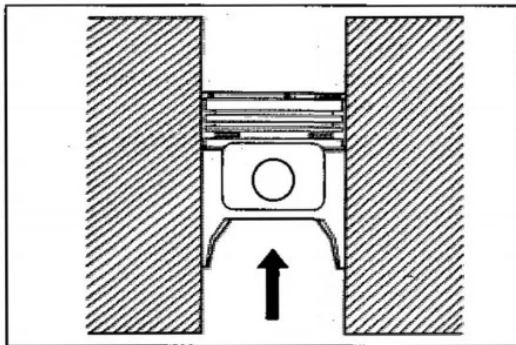

2. Measure ring end gap.
 - (1) Insert ring into cylinder using a piston.

Fig. 3-91

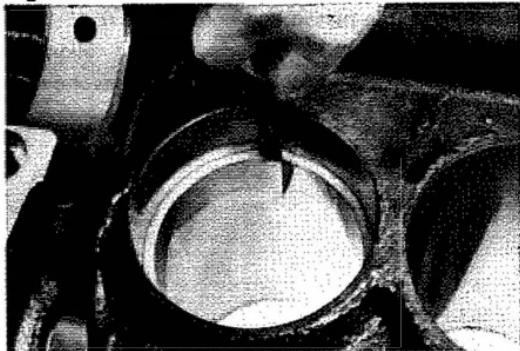

- (2) Measure end gap. If it exceeds specification, ring must be replaced.

Top

0.20 – 0.56 mm (0.0079 – 0.0220 in)

2nd

0.20 – 0.58 mm (0.0079 – 0.0228 in)

Oil for NPR

0.20 – 0.88 mm (0.0079 – 0.0346 in)

for RIKEN

0.20 – 0.58 mm (0.0079 – 0.0228 in)

Fig. 3-92

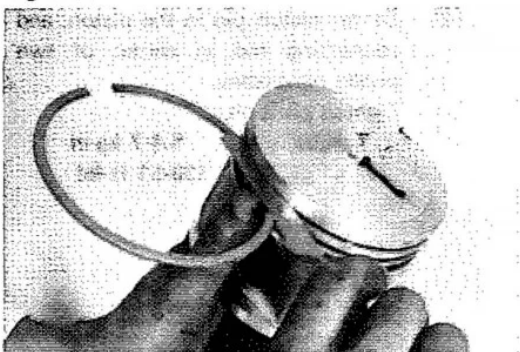

3. Measure ring groove clearance. If it exceeds specification, replace ring and/or piston.

Top ring

0.03-0.06 mm (0.0012-0.0024 in)

2nd ring

0.02-0.06 mm (0.0008-0.0024 in)

Fig. 3-93

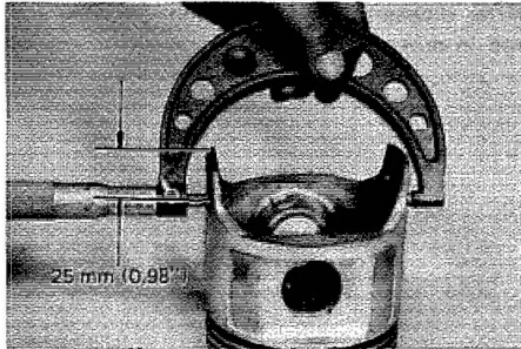

4. Measure piston clearance.
- (1) Measure piston diameter at right angle to piston pin center line. Measurement must be made at normal temperature (20°C or 68°F).
Piston diameter (STD)
93.97-94.02 mm (3.6996-3.7016 in)

Fig. 3-94

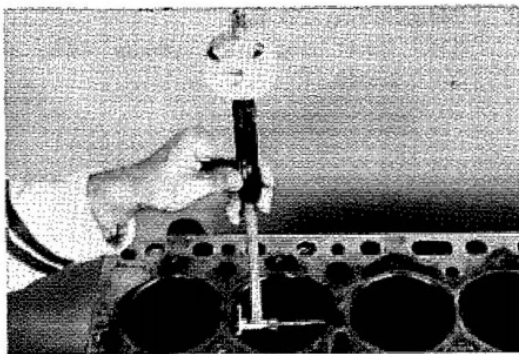

- (2) Measure cylinder bore and subtract piston measurement. If clearance exceeds specification, replace piston.
Piston clearance
0.03-0.05 mm (0.0012-0.0020 in)

Fig. 3-95

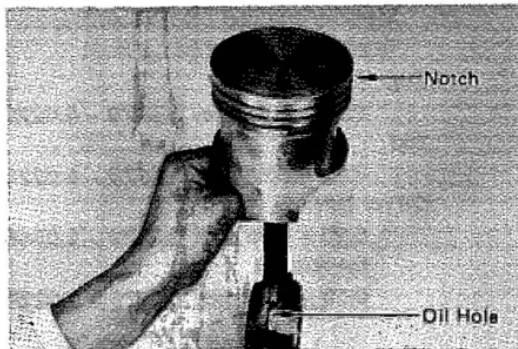

5. Assemble piston and connecting rod.
- (1) Assemble piston and rod aligning piston notch and rod hole as shown.

Fig. 3-96

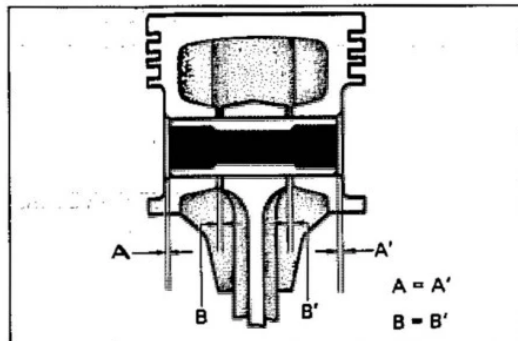

- (2) Center piston pin in the piston, and connecting rod in center of two piston pin bosses. Tighten pin bolt.
Torque **5.4-7 kg-m**
(39-51 ft-lb)

Fig. 3-97

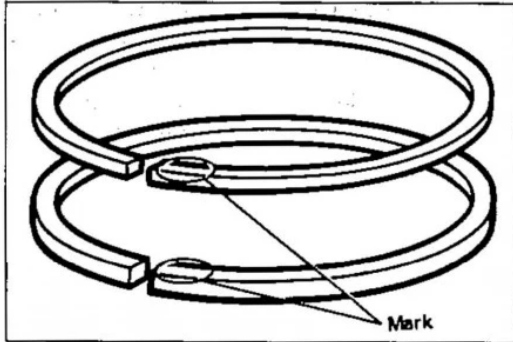

6. Position two compression rings with code marks facing up. Assemble rings.

Fig. 3-98

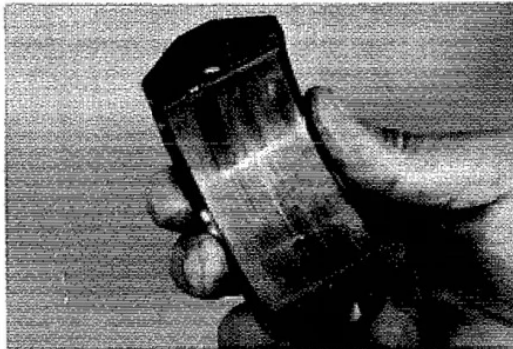

Crankshaft and Bearing

1. Inspect bearings for flaking or scoring. If bearings are damaged, replace.

Fig. 3-99

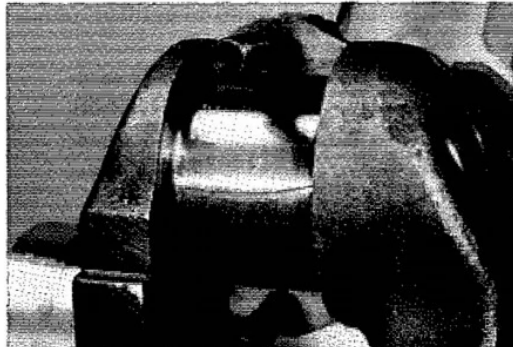

2. Measure crankpin oil clearance.
 - (1) Lay strip of plastigage across pin.

Fig. 3-100

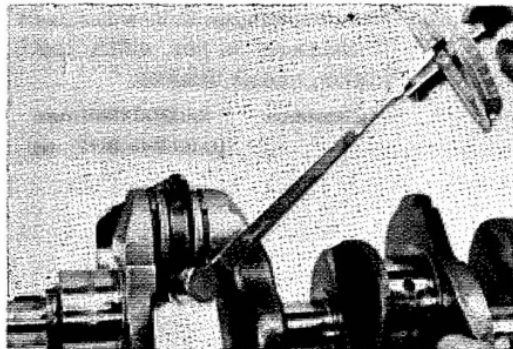

- (2) Tighten cap nuts to specified torque.

| | |
|---------------|----------------------|
| Torque | 4.8-7.6 kg-m |
| | (35-55 ft-lb) |

– Note –
Do not turn connecting rod.

Fig. 3-101

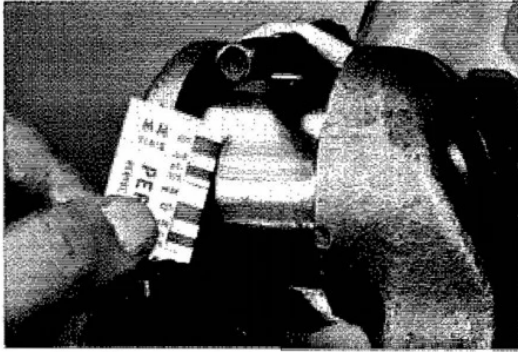

- (3) Measure plastigage at its widest point. If clearance is not within specification, replace bearings.

Clearance **0.02-0.06 mm**
 (0.0008-0.0024 in)

Fig. 3-102

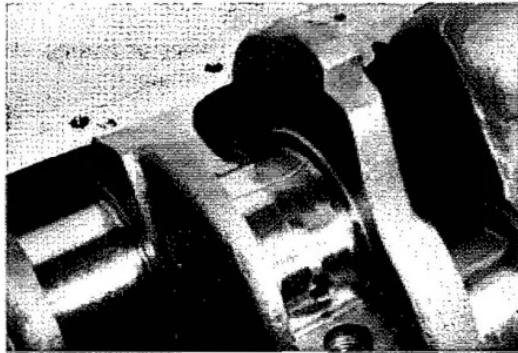

3. Measure main journal oil clearance.
 (1) Lay strip of plastigage across main journal.

Fig. 3-103

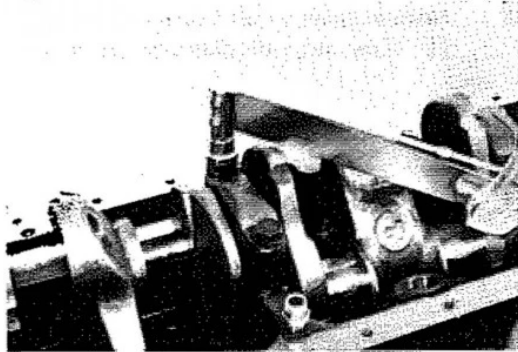

- (2) Tighten cap bolts to specified torque.

Torque

No.1–No.3: 12.5-15 kg-m
 (90-108 ft-lb)

No.4 : 10.5-13 kg-m
 (76-94 ft-lb)

Fig. 3-104



- (3) Measure plastigage at its widest point. If clearance is not within specification, replace bearings.

Clearance **0.020-0.044 mm**
 (0.0008-0.0017 in)

Fig. 3-105

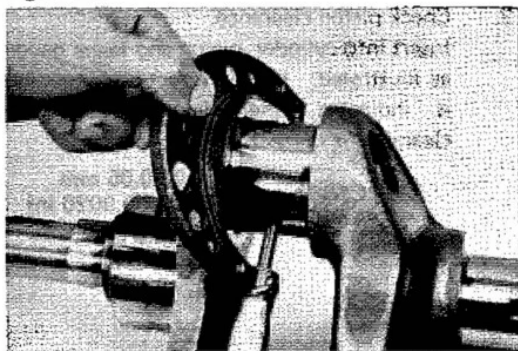

4. Measure crankpin and main journals. If wear is excessive, crankshaft must be reground or replaced.

Standard

Main Journal

| | |
|---------------|--|
| Front | 66.972-66.996 mm (2.6367-2.6376 in) |
| Second | 68.472-68.496 mm (2.6957-2.6967 in) |
| Third | 69.972-69.996 mm (2.7548-2.7557 in) |
| Rear | 71.472-71.496 mm (2.8139-2.8148 in) |

| | |
|--------------------|--|
| Pin journal | 53.98-54.00 mm (2.1252-2.1260 in) |
|--------------------|--|

Crank pin and main journal U/S bearings.

U/S bearing sizes:
 U/S 0.05
 U/S 0.25
 U/S 0.50

Fig. 3-106

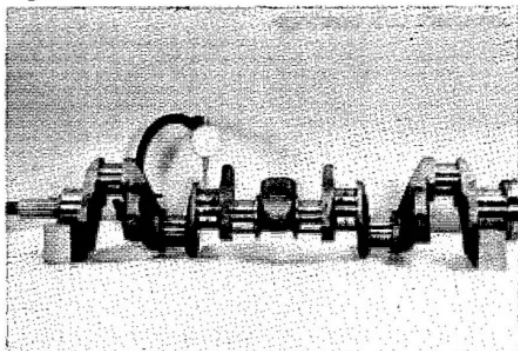

5. Check crankshaft for runout and if it exceeds limit, replace.

Runout limit 0.1 mm (0.004 in)

Piston sizes:

| | |
|-----------------|--|
| O/S 0.50 | 94.46-94.51 mm (3.7189-3.7209 in) |
| O/S 1.00 | 94.96-95.01 mm (3.7386-3.7405 in) |
| O/S 1.50 | 95.46-95.51 mm (3.7583-3.7602 in) |

CYLINDER BORING

1. If cylinder bore is worn or tapered over limit or if cylinder wall is scored, rebore all six cylinders and install oversized pistons.
2. O/S pistons with pins are available in the sizes listed. Replace pistons in matched sets based on cylinder to be rebored.

Fig. 3-107

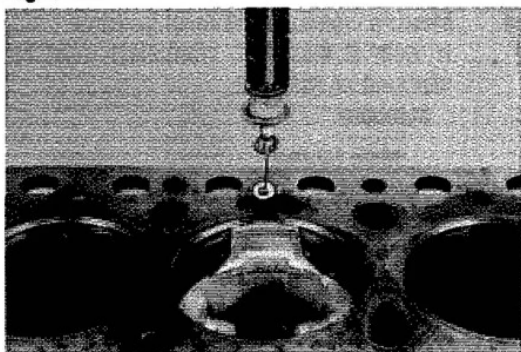

3. Check piston clearance.
Insert into cylinder, piston and feeler gauge as illustrated. If the correct scale reading is indicated, the piston to cylinder clearance is correct.

| | |
|---------------------|--|
| Feeler gauge | 0.03-0.05 mm (0.0012-0.0020 in) |
| Scale pull | 1.0-2.5 kg (2.2-5.5 lb) |

Fig. 3-108

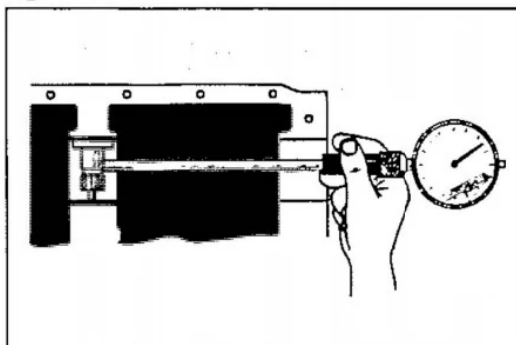

CAMSHAFT BEARING

1. Inspect bearing surface for flaking, melting, and burning, and replace if damaged.
2. Inspect the oil clearance by measuring the difference between the camshaft journal diameter and the bearing inner diameter. If clearance exceeds specification, replace bearing and/or reground camshaft.

| | |
|------------------|--|
| Clearance | 0.025-0.075 mm (0.0010-0.0030 in) |
|------------------|--|

U/S bearing sizes:
U/S 0.25
U/S 0.50

Camshaft U/S bearings

Fig. 3-109

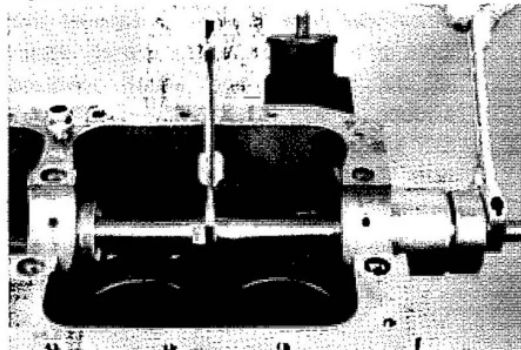

Camshaft Bearing Replacement

1. Drive out plug from cylinder block.
2. Using SST [09215-60010], remove front and second bearings towards front, third and rear bearings towards rear.

Fig. 3-110

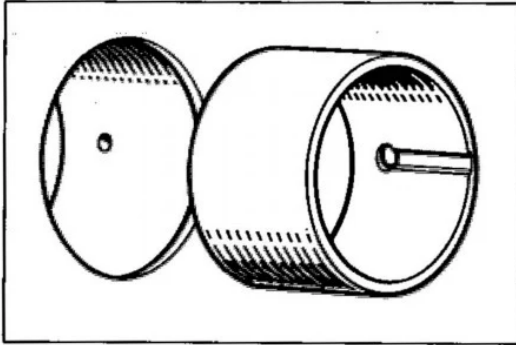

3. Align the bearing oil hole, install new selected bearings using SST [09215-60010]. If bearings are correctly installed, only a slight reaming is required.
4. Install new plug applied with liquid sealer.

ASSEMBLY

Assemble in numerical order.

- Thoroughly clean the parts to be assembled.
- Apply clean engine oil on the sliding and rotating surfaces of the parts before assembly.

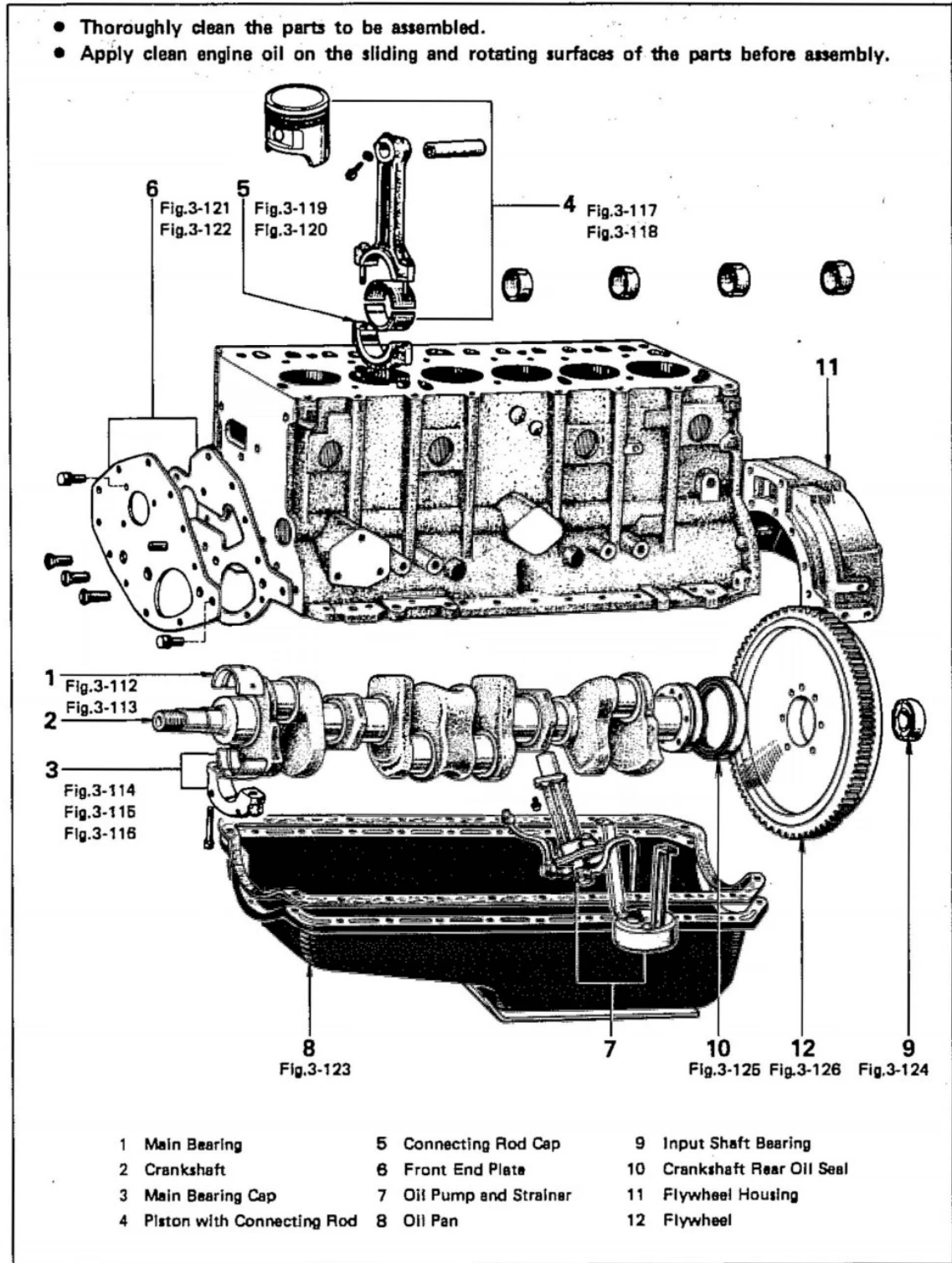
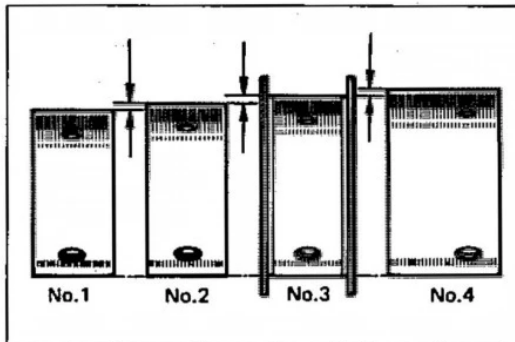

Fig. 3-111

Fig. 3-112



All main bearings are different. Install bearings in block and caps, lubricating face only.

Fig. 3-113

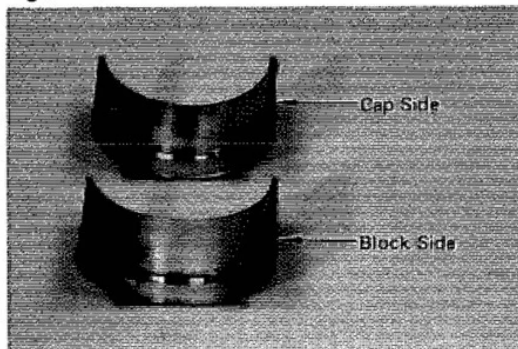

Front (No.1) and rear (No.4) bearings provided oil hole must be installed at cylinder block side.

Fig. 3-114

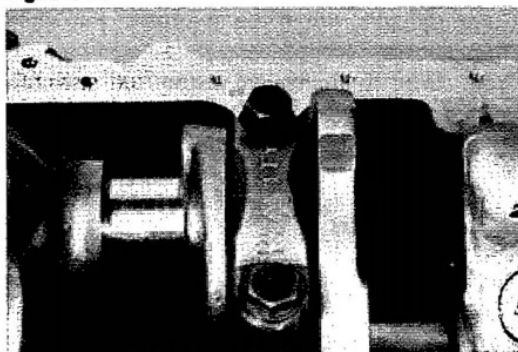

Face the arrow mark toward front.

Fig 3-115

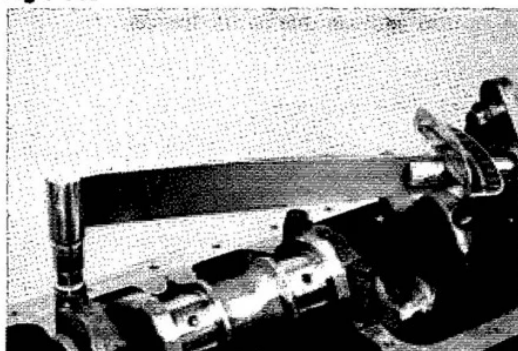

Tighten bearing cap to specified torque.

Torque No.1–No.3 : 12.5-15 kg-m
(90-108 ft-lb)
No.4 : 10.5-13 kg-m
(76-94 ft-lb)

Fig. 3-116

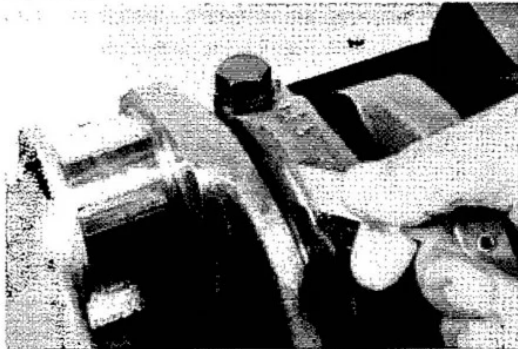

Check crankshaft thrust clearance.

Thrust clearance **0.06-0.16 mm**
(0.0024-0.0063 in)

Make sure the crankshaft rotates smoothly.

Fig. 3-117

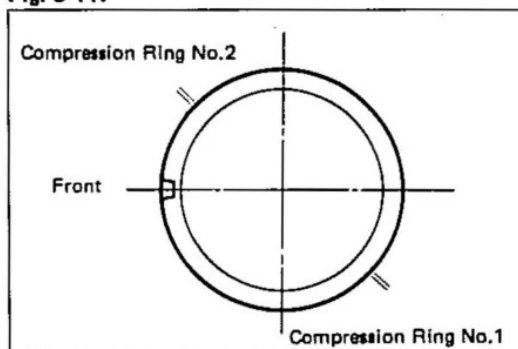

Position ring gap in direction as shown.

Fig. 3-118

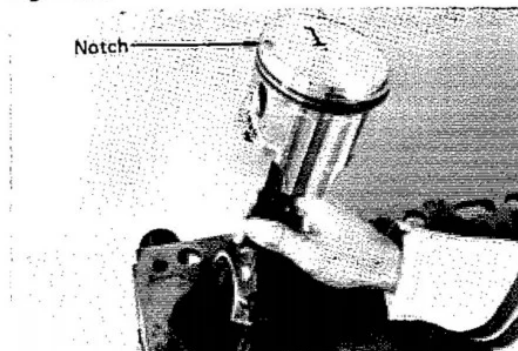

Cover rod bolts with a hose to protect crankshaft from damage.

Push correctly numbered piston/rod assembly with notch forward.

⊕ mark on connecting rod should face rearward.

Fig. 3-119

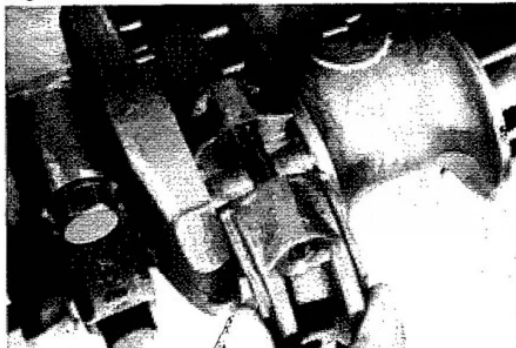

Align rod and cap marks, fit the cap.

Fig. 3-120

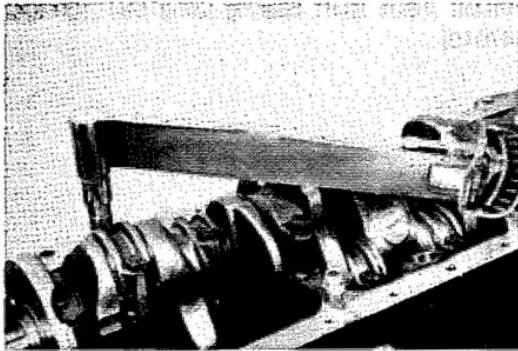

Tighten rod cap to specified torque and check rod thrust clearance.

Torque 4.8-7.6 kg-m (35-55 ft-lb)
Thrust clearance 0.11-0.23 mm
 (0.0043-0.0091 in)

Make sure the crankshaft rotates smoothly.

Fig. 3-121

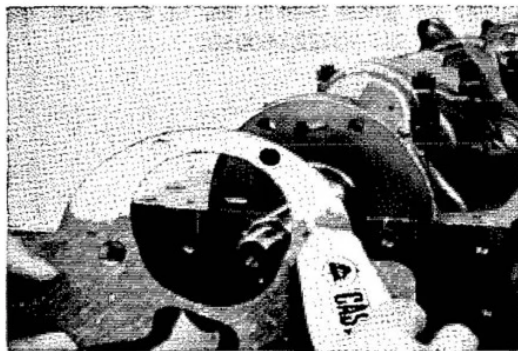

Apply liquid sealer onto end plate gasket both surfaces.

Fig. 3-122

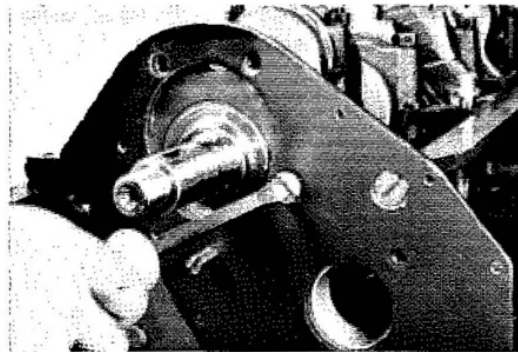

Tighten the undercut flat head screws to locate end plate correctly, then tighten the bolt.

Fig. 3-123

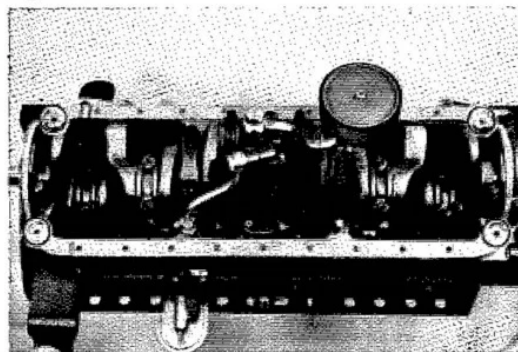

Apply liquid sealer at four places as shown.

Fig. 3-124

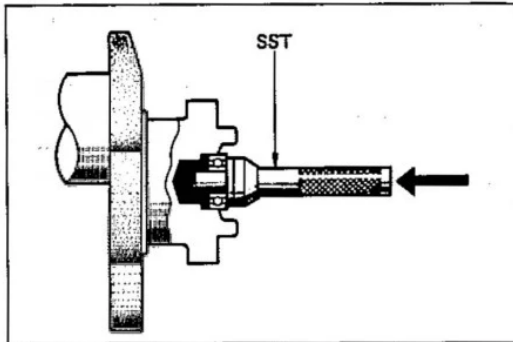

Install input shaft bearing using SST [09304-47010].

Fig. 3-125

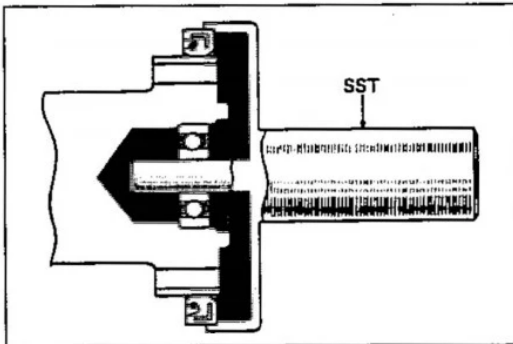

Apply MP grease onto oil seal lip and install oil seal using SST [09223-60010].

Fig. 3-126

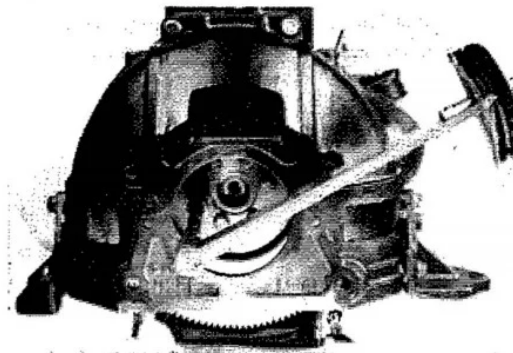

Coat flywheel bolt threads with liquid sealer. Tighten flywheel to specified torque.

Torque

**8.1-8.5 kg-m
(59-61 ft-lb)**

LUBRICATING SYSTEM

| | Page |
|----------------------------------|------|
| LUBRICATING SYSTEM CIRCUIT | 4-2 |
| OIL PUMP | 4-3 |
| DISASSEMBLY | 4-3 |
| INSPECTION | 4-4 |
| ASSEMBLY | 4-6 |

LUBRICATING SYSTEM CIRCUIT

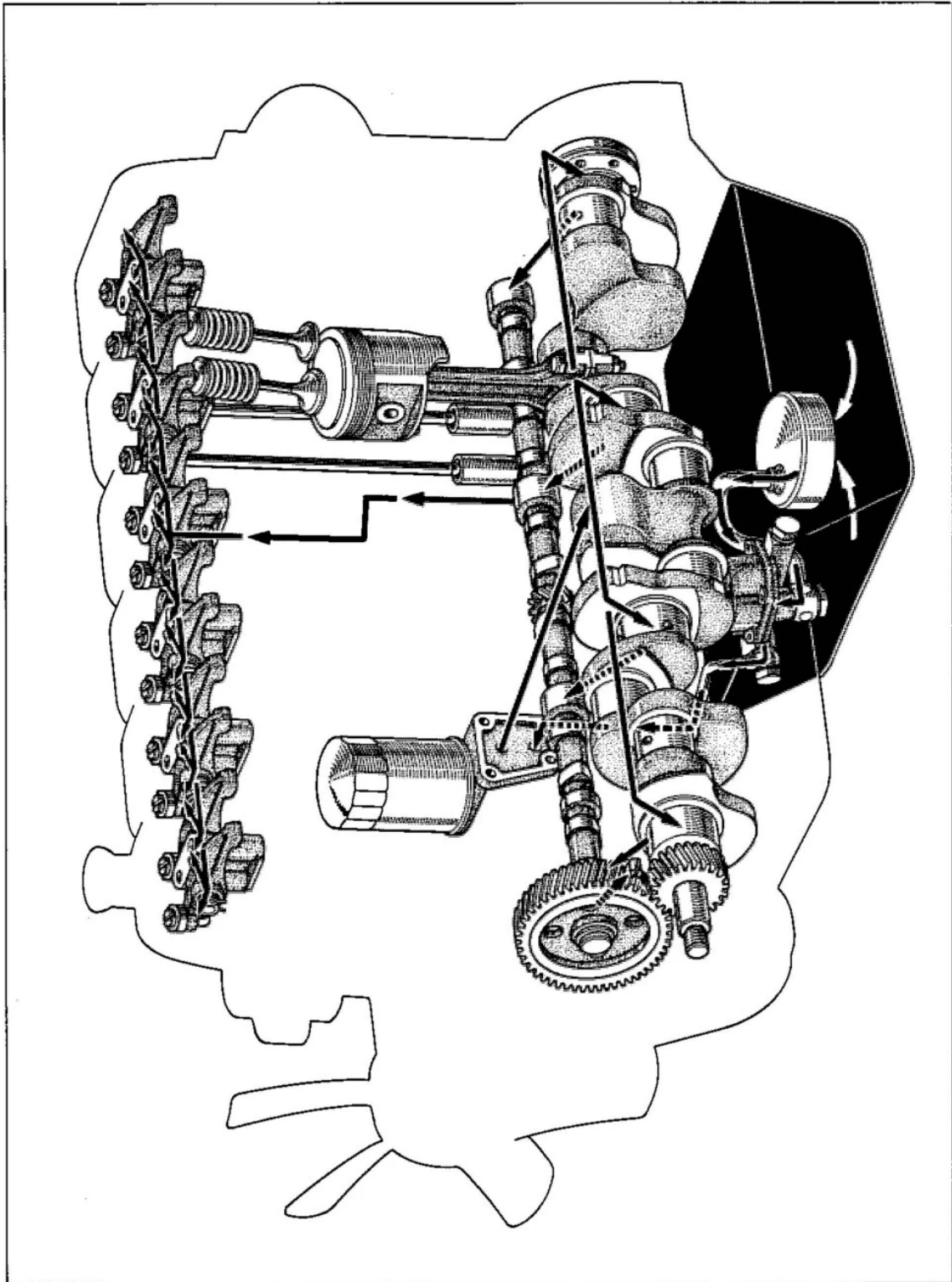

Fig. 4-1

OIL PUMP DISASSEMBLY

Disassemble in numerical order.

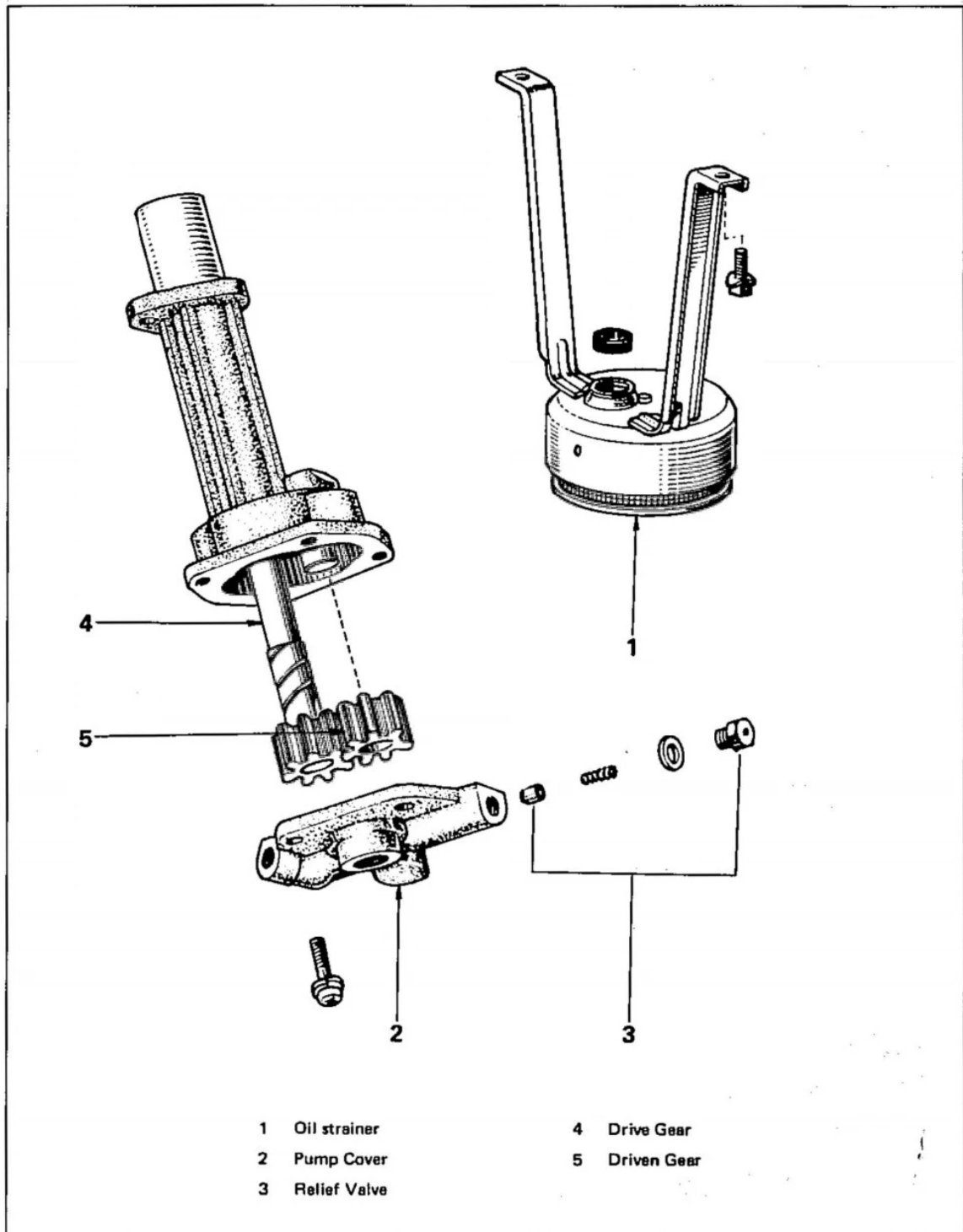
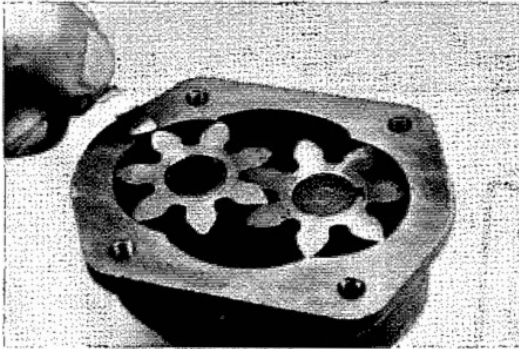

Fig. 4-2

Fig. 4-3

**INSPECTION**

1. Measure tip clearance. If it exceeds limit, replace gear and/or pump assembly.

Limit

0.2 mm (0.008 in)

Standard

0.03—0.11 mm (0.0012—0.0043 in)

Fig. 4-4

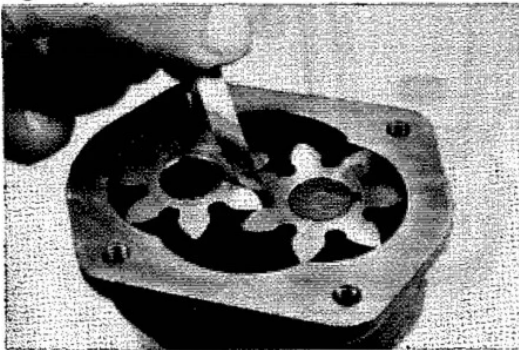

2. Measure backlash. If it exceeds limit, replace gears.

Limit

0.95 mm (0.0374 in)

Standard

0.05—0.07 mm (0.0020—0.0028 in)

Fig. 4-5

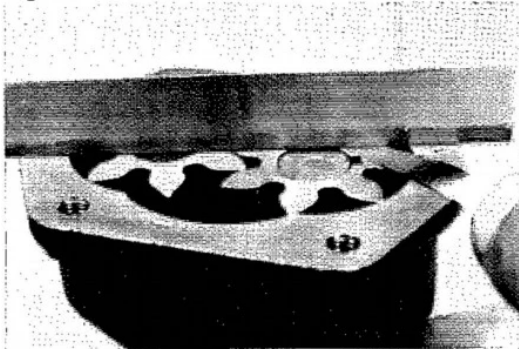

3. Measure side clearance. If it exceeds limit, replace gear and/or pump assembly.

Limit

0.15 mm (0.0059 in)

Standard

0.03—0.09 mm (0.0012—0.0035 in)

Fig. 4-6

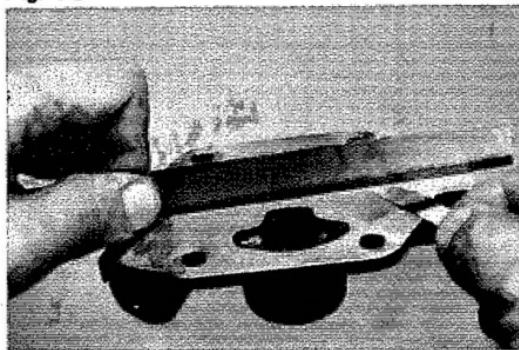

4. Measure cover wear. If the clearance exceeds limit, replace cover.

Limit

0.15 mm (0.0059 in)

Fig. 4-7

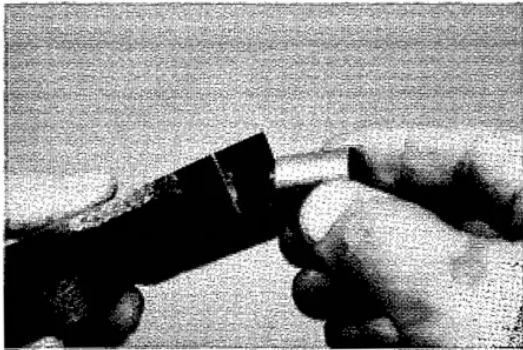

5. Inspect relief valve for scoring and wear. If damaged, replace valve or pump assembly.

Fig. 4-8

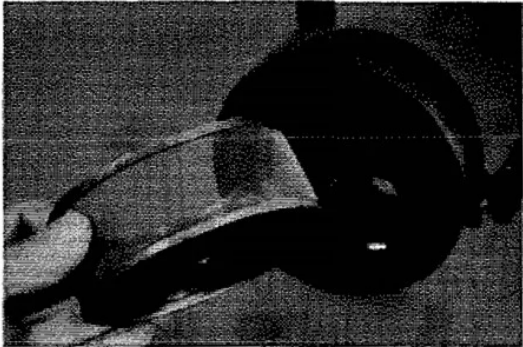

6. Inspect oil strainer for rust, tear and clog. If damaged, replace.

ASSEMBLY

Assemble in numerical order.

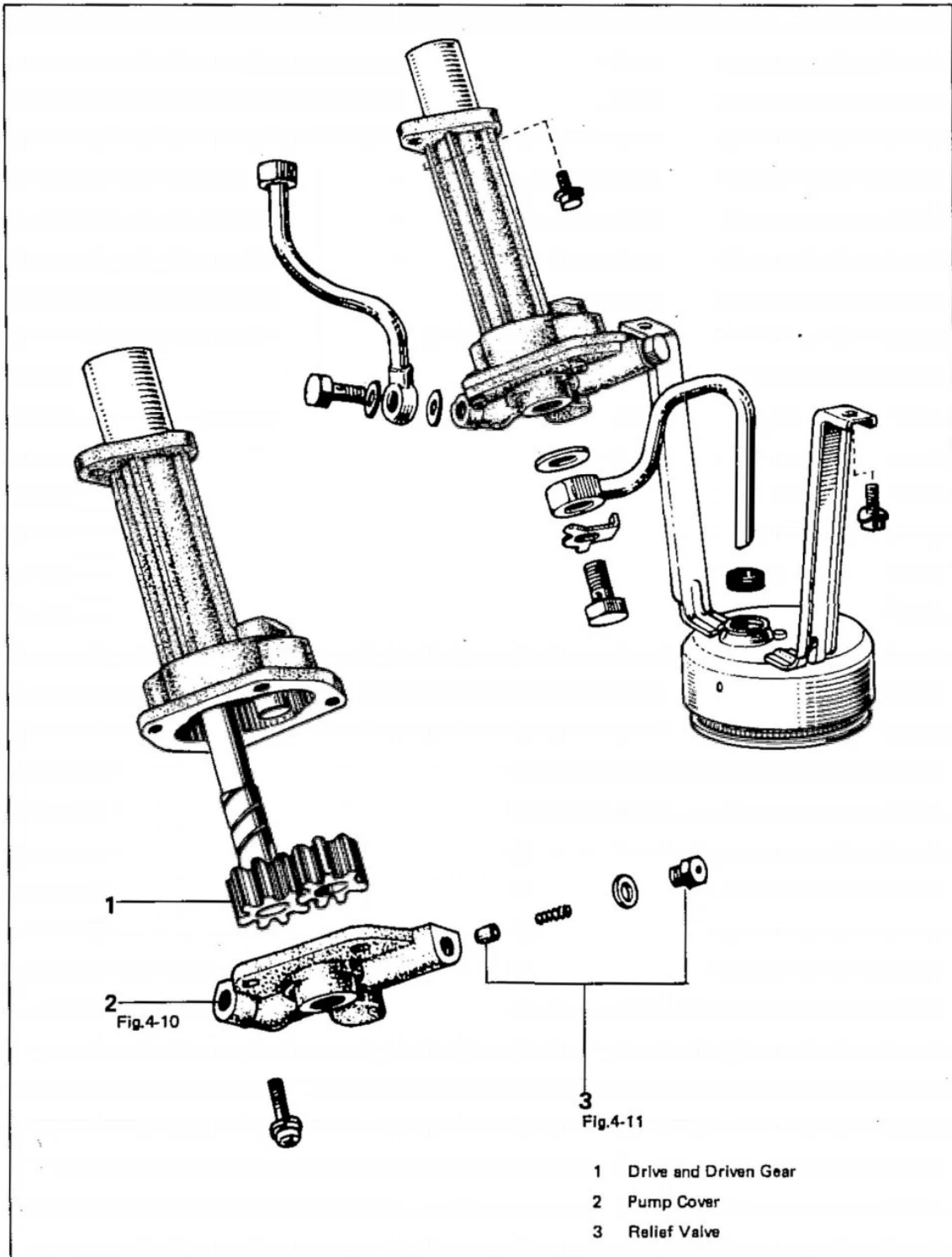
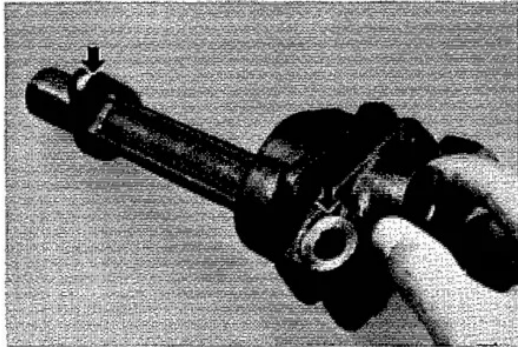

Fig. 4-9

Fig. 4-10



Install pump cover in direction as shown. Discharge hole should be pointed toward pump body bolt hole.

Fig. 4-11

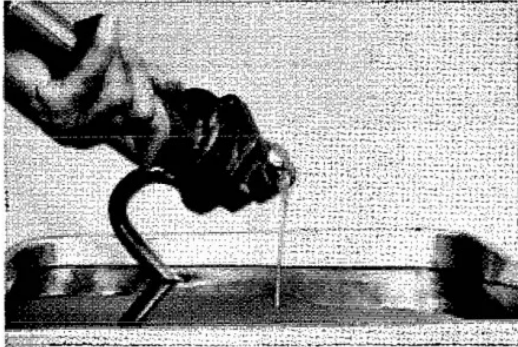

Check pump operation. Submerge pump inlet pipe into fresh engine oil, and turn the shaft clockwise with a screwdriver. This should cause the oil to come out from discharge hole. Close the discharge hole with thumb, and turn the shaft as before. Make sure that the shaft becomes heavy.

MEMO

COOLING SYSTEM

| | Page |
|-----------------------------|------|
| COOLING SYSTEM CIRCUIT..... | 5-2 |
| WATER PUMP | 5-3 |
| DISASSEMBLY | 5-3 |
| ASSEMBLY | 5-4 |
| FLUID COUPLING | 5-6 |
| RADIATOR | 5-7 |
| THERMOSTAT | 5-7 |

COOLING SYSTEM CIRCUIT

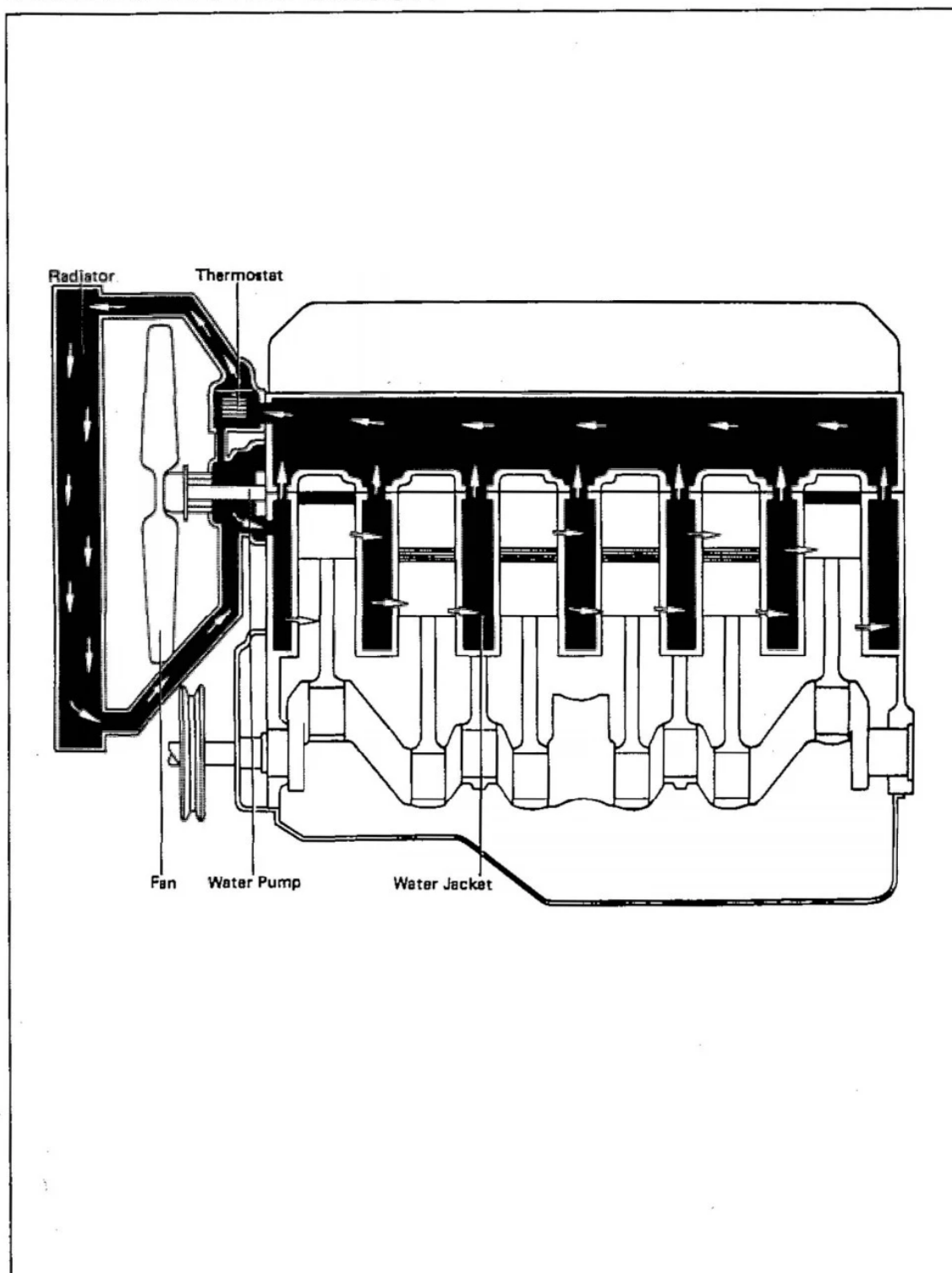

Fig. 5-1

WATER PUMP DISASSEMBLY

Disassemble in numerical order.

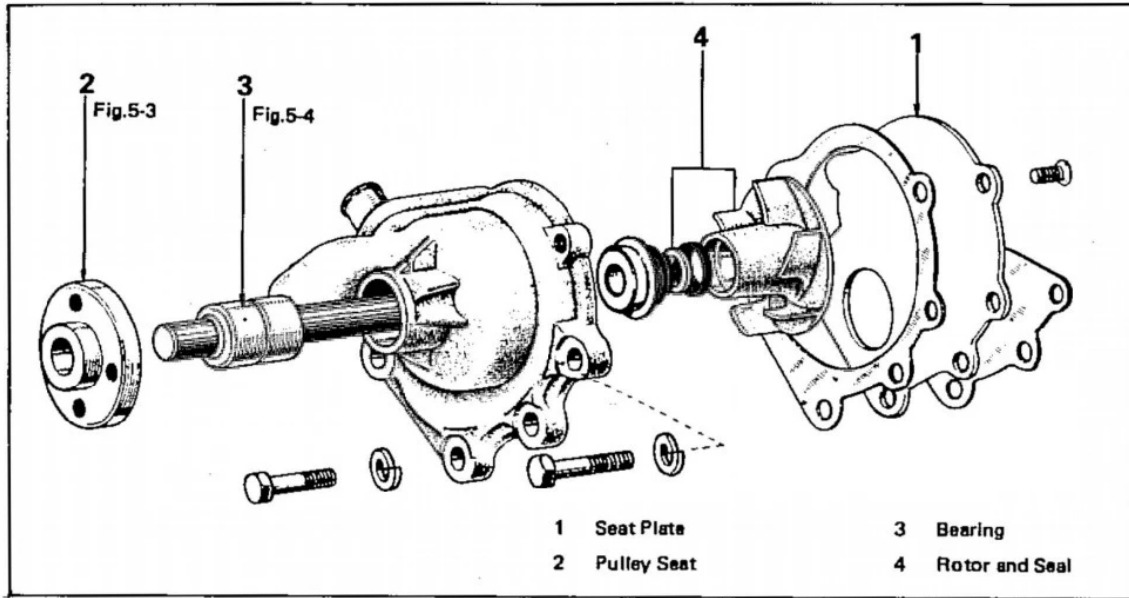
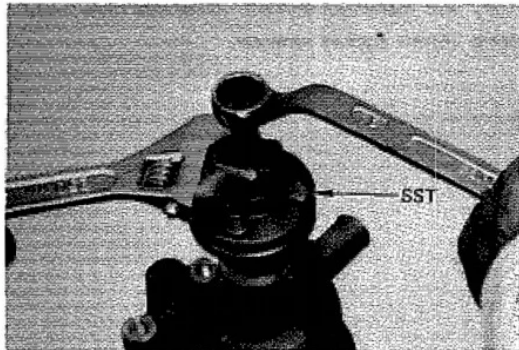

Fig. 5-2

Fig. 5-3



Using SST [09235-60010], remove pulley seat.

Fig. 5-4

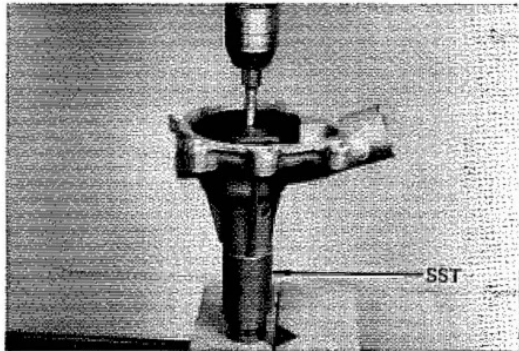

Using SST [09238-40010], press bearing out of the pump body.

ASSEMBLY

Assemble in numerical order.

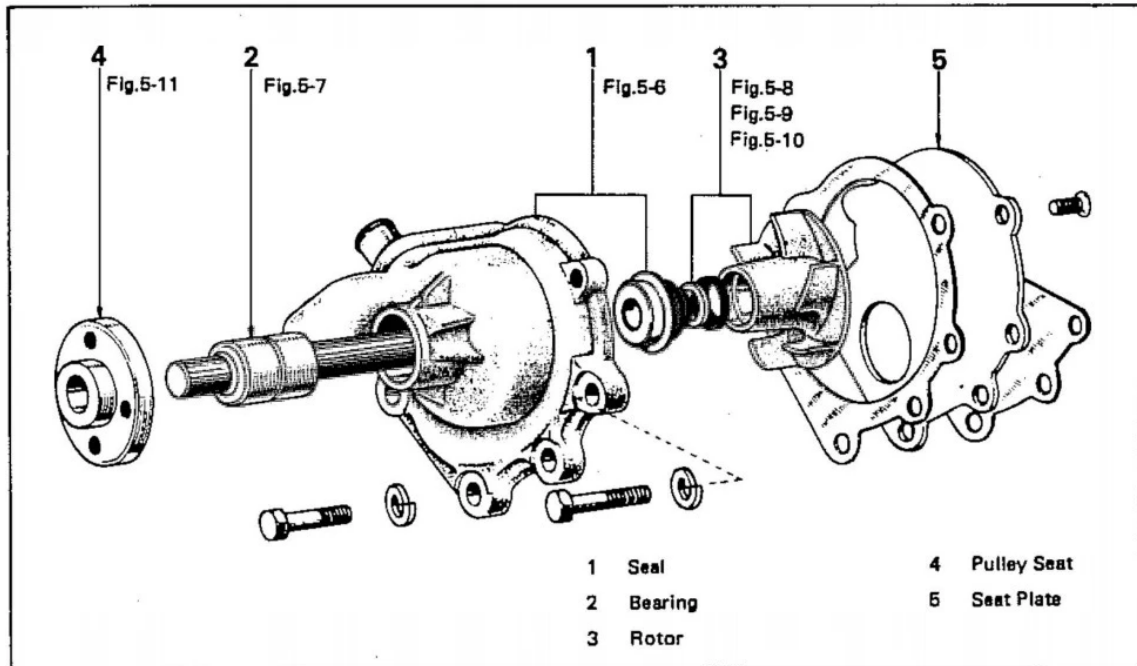
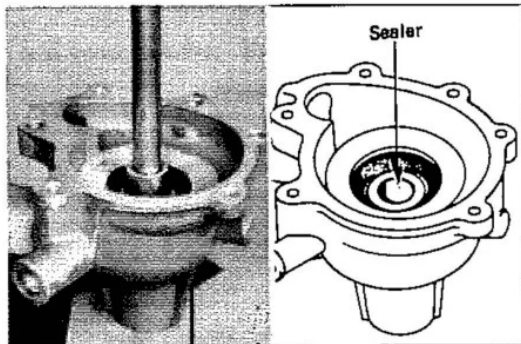

Fig. 5-5

Fig. 5-6



Apply a small amount of liquid sealer to pump body seal installing surface, press seal into body, using 26mm socket wrench.

Fig. 5-7

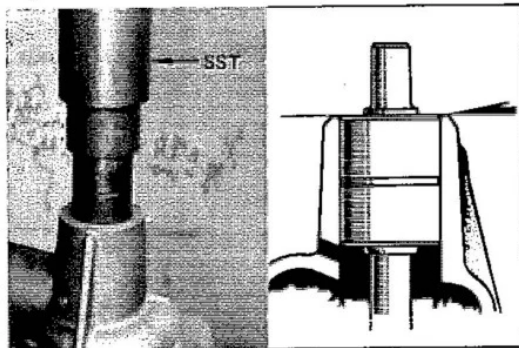

Using SST [09238-40010], press new bearing into body until its end surface is flush with body end.

Fig. 5-8



Assemble rubber seal and thrust plate into rotor.

Fig. 5-9

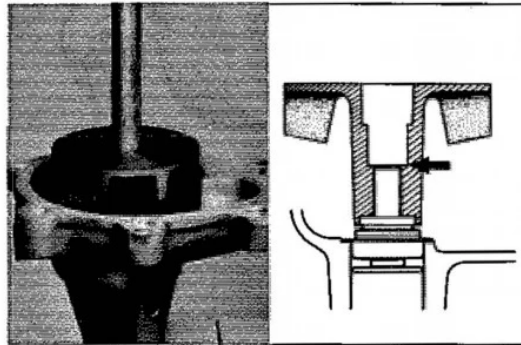

Apply a small amount of silicone oil or engine oil to the seal surfaces. Press in rotor until its surface indicated by arrow is flush with bearing shaft end.

Fig. 5-10

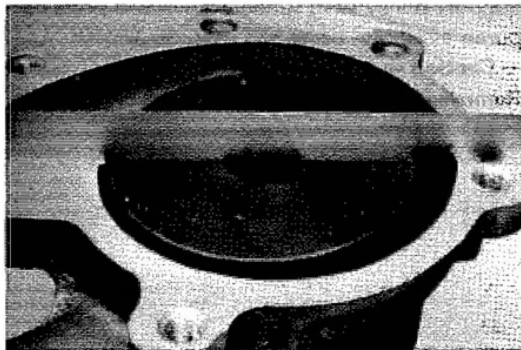

Make sure that the rotor end is flush with pump body end surface.

Fig. 5-11

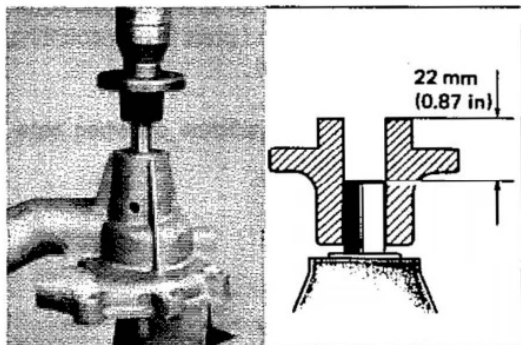

Support the shaft from the rotor end with a suitable bar and press in pulley seat to the depth as shown.

– Note –

After assembling the rotor, check it for smooth rotation with the water pump plate in installed condition.

FLUID COUPLING

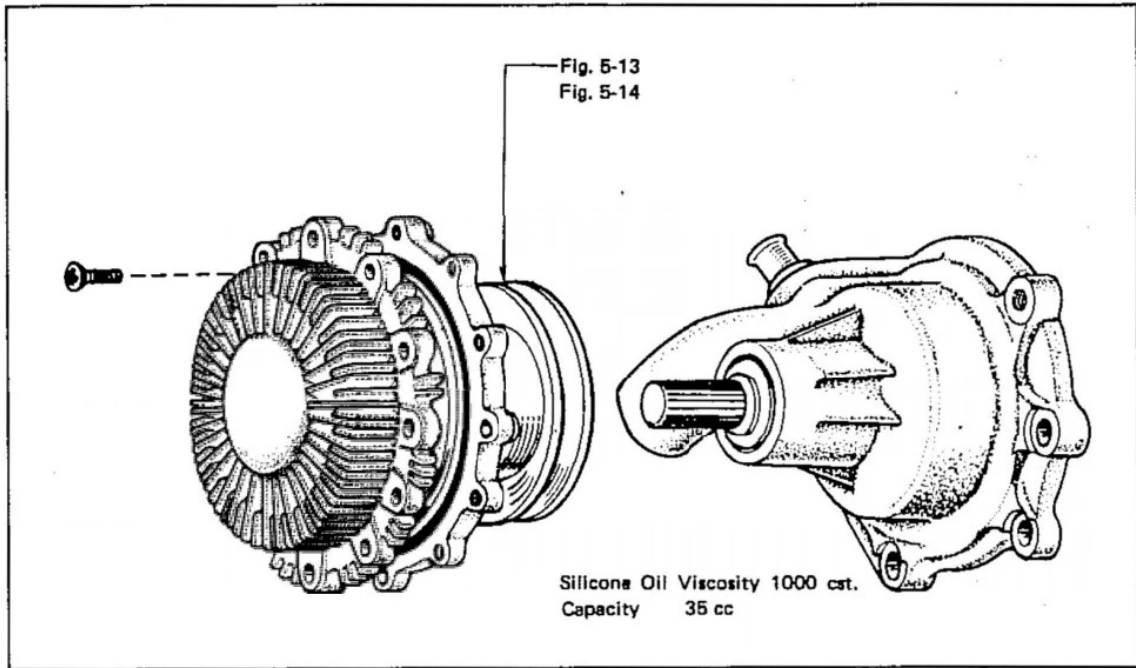

Fig. 5-12

Fig. 5-13

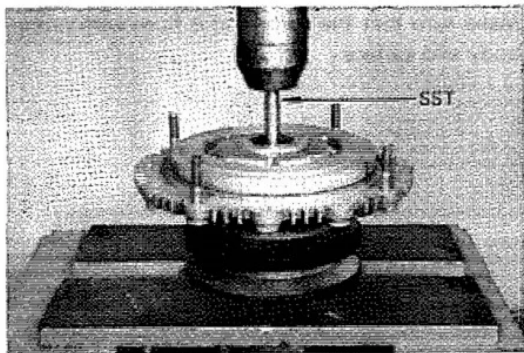
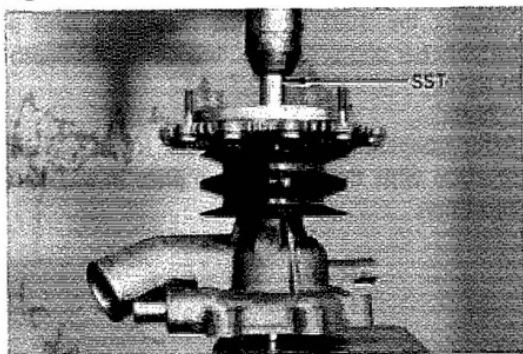

Fig. 5-14



Support pulley with suitable anvils and press out pump assembly, using SST [09236-36010].

— Caution —

Removed coupling cannot be reused.



Support pump bearing shaft end from the rotor end with a suitable bar and press in new coupling, using SST [09236-36010].

— Note —

Take care not to drop silicone oil when separating new coupling.

Fig. 5-15

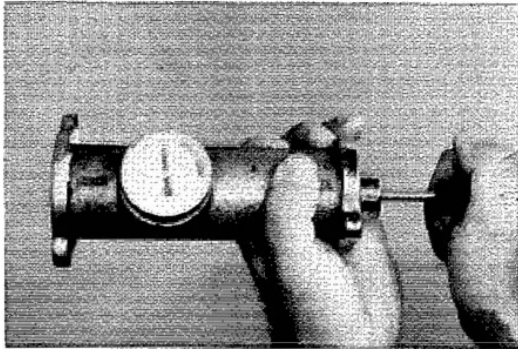

Fig. 5-16

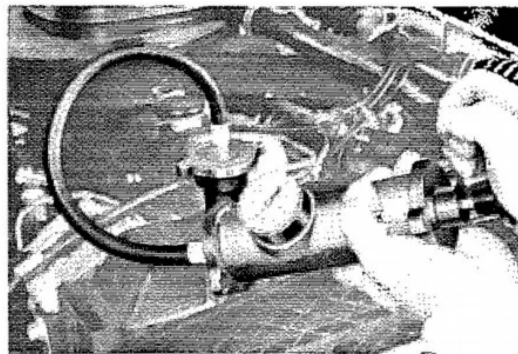
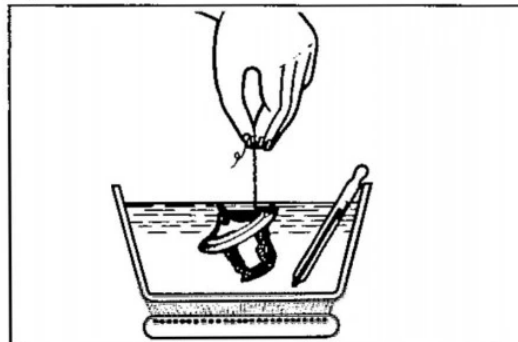

Fig. 5-17



RADIATOR INSPECTION



1. Inspect the radiator cap regulation pressure, and vacuum valves for spring tension and seating. If the pressure gauge drops rapidly and excessively, replace the radiator cap.

Valve opening pressure limit

0.6 kg/cm² (8.5 psi)

Standard

0.9 kg/cm² (12.8 psi)



2. Inspect the cooling system for leaks. Attach the pressure tester to the radiator, pump the tester to the specified pressure. If the pressure gauge drops, inspect all hoses and fittings for an external leak. If no external leak is found an internal intake manifold, block or heater core leak should be suspected.

THERMOSTAT INSPECTION



1. Replace if the valve remains open at normal temperature or does not have proper tightness when fully closed.
2. Immerse the thermostat in the water, and check the valve opening temperatures by heating the water gradually.

The valve is satisfactory if it starts to open at 80.5° to 83.5°C (177° to 182°F) and opens to more than 8mm (0.31 in.) at 95°C (203°F).

Replace if necessary.

FUEL SYSTEM

| | Page |
|----------------------------------|------|
| FUEL PUMP | 6- 2 |
| DISASSEMBLY | 6- 2 |
| INSPECTION | 6- 3 |
| ASSEMBLY | 6- 3 |
| CARBURETOR | 6- 6 |
| CARBURETOR CIRCUITS | 6- 6 |
| DISASSEMBLY | 6- 8 |
| INSPECTION | 6-13 |
| ASSEMBLY | 6-17 |
| ADJUSTMENT | 6-24 |

FUEL PUMP

DISASSEMBLY

Disassemble in numerical order.

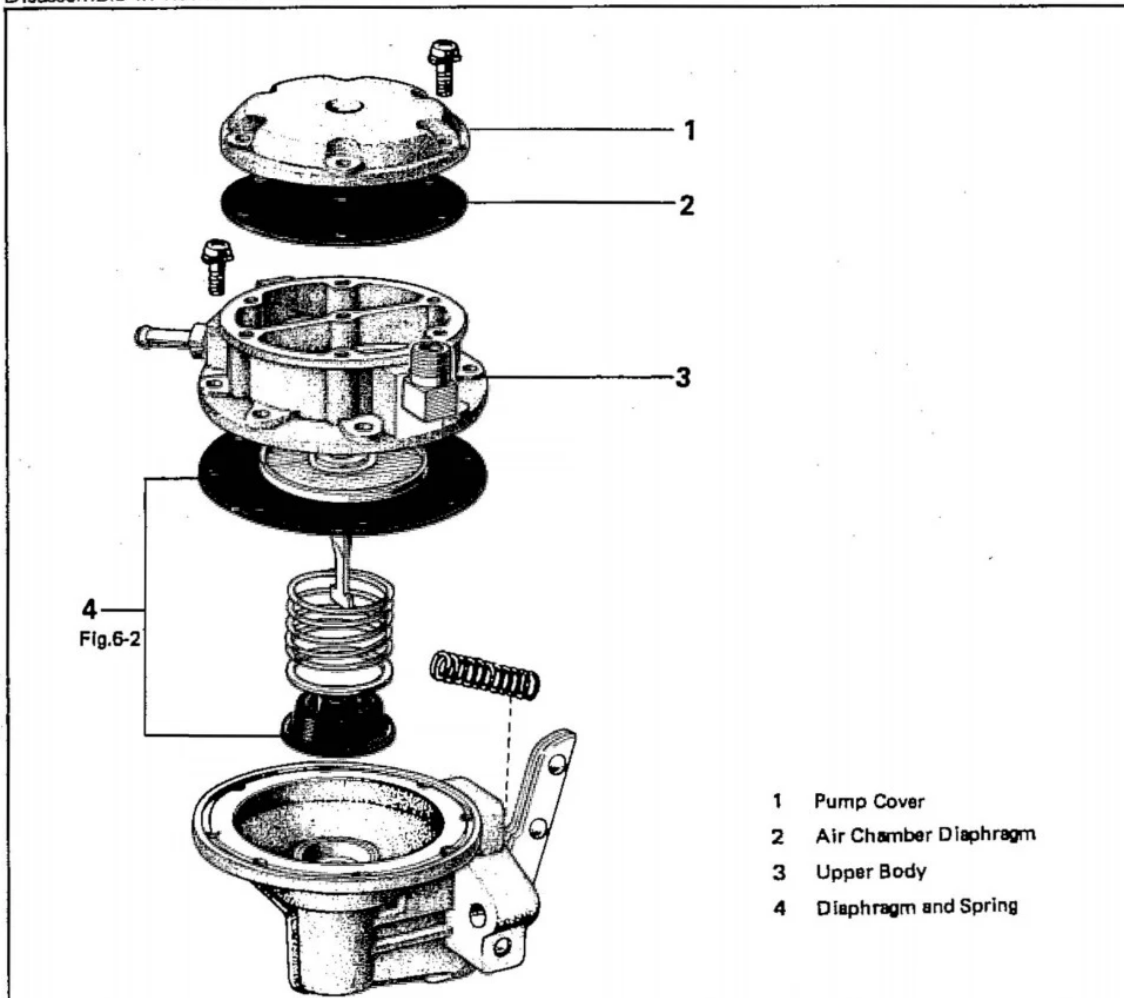

Fig. 6-1

Fig. 6-2



Remove diaphragm by turning it 90 degrees clockwise or counterclockwise while pushing.

Fig. 6-3

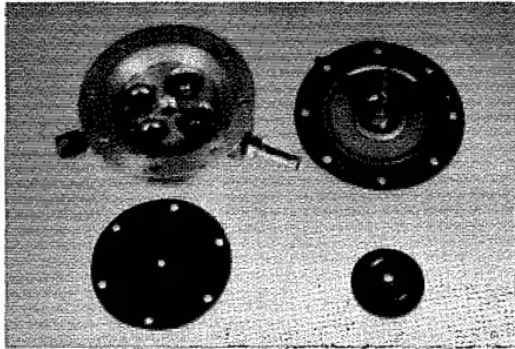

INSPECTION

Inspect diaphragms for tear and check valves for defective operation. Replace if damaged.

ASSEMBLY

Assemble in numerical order.

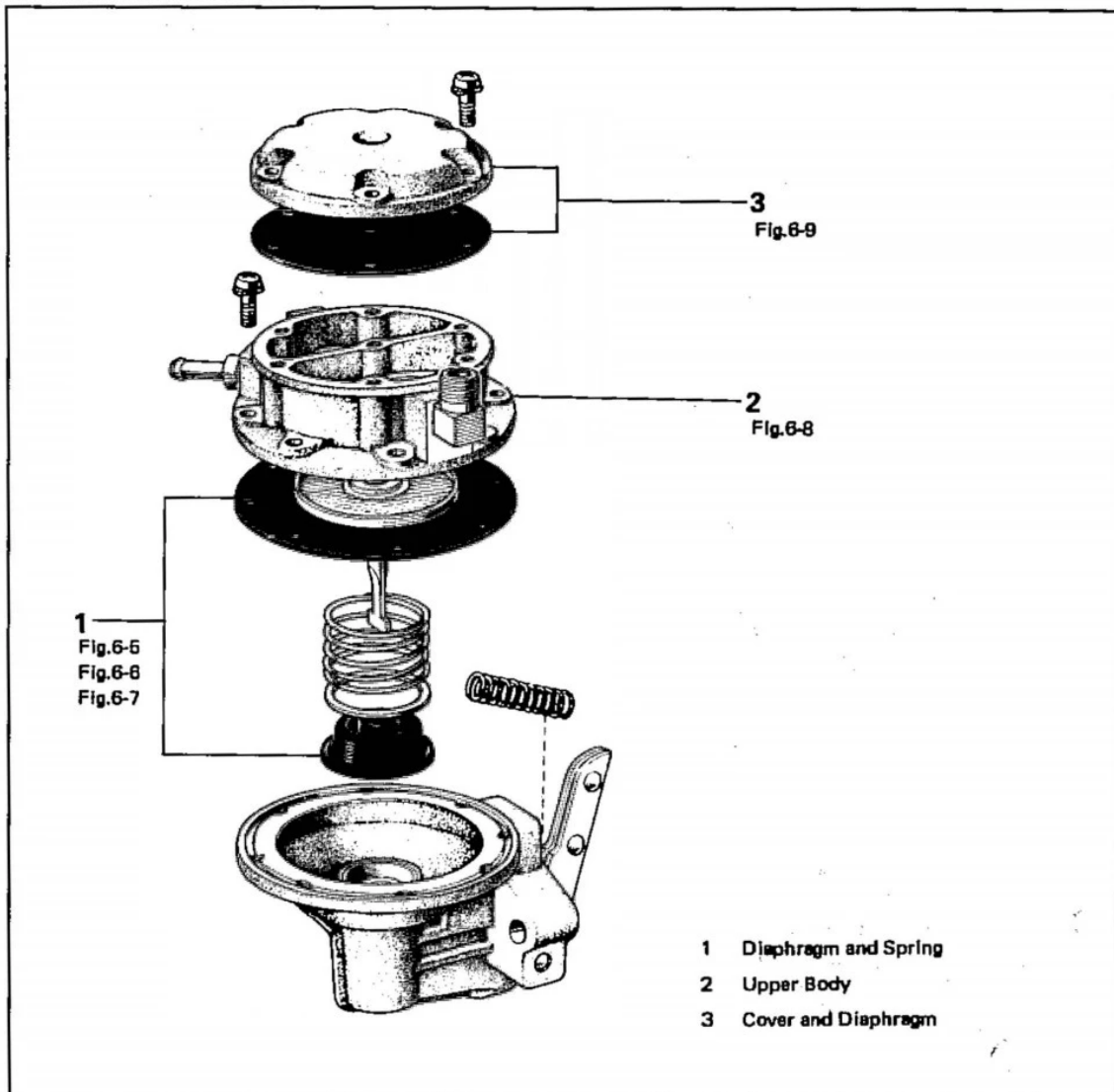
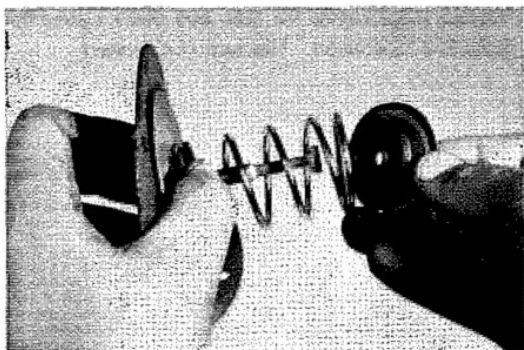

Fig. 6-4

Fig. 6-5



Assemble spring, retainer and oil seal onto diaphragm rod.

Fig. 6-6



Insert diaphragm rod into lower body hole. While compressing the spring turn diaphragm 90 degrees clockwise or counterclockwise to mesh the rod and rocker arm.

Fig. 6-7



After assembling, the tab of diaphragm must face the position indicated by arrow.

Fig. 6-8

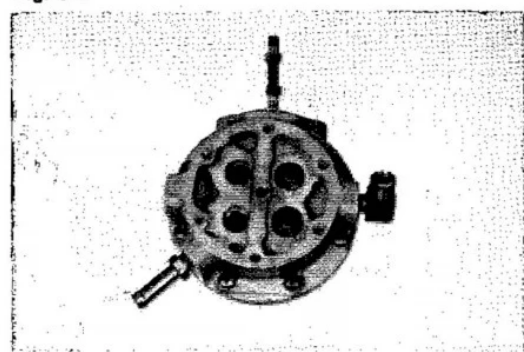

Assemble lower and upper body in direction as shown.

Fig. 6-9

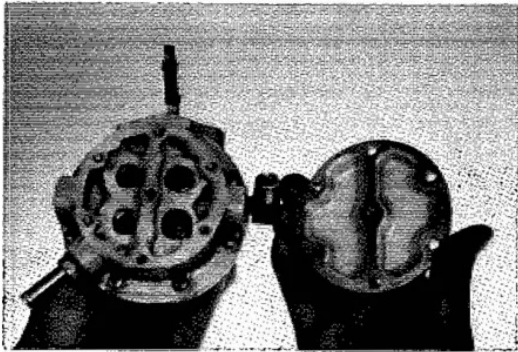

Assemble upper body and cover over the diaphragm.
Inlet and outlet chamber separating walls should be aligned.

Fig. 6-10

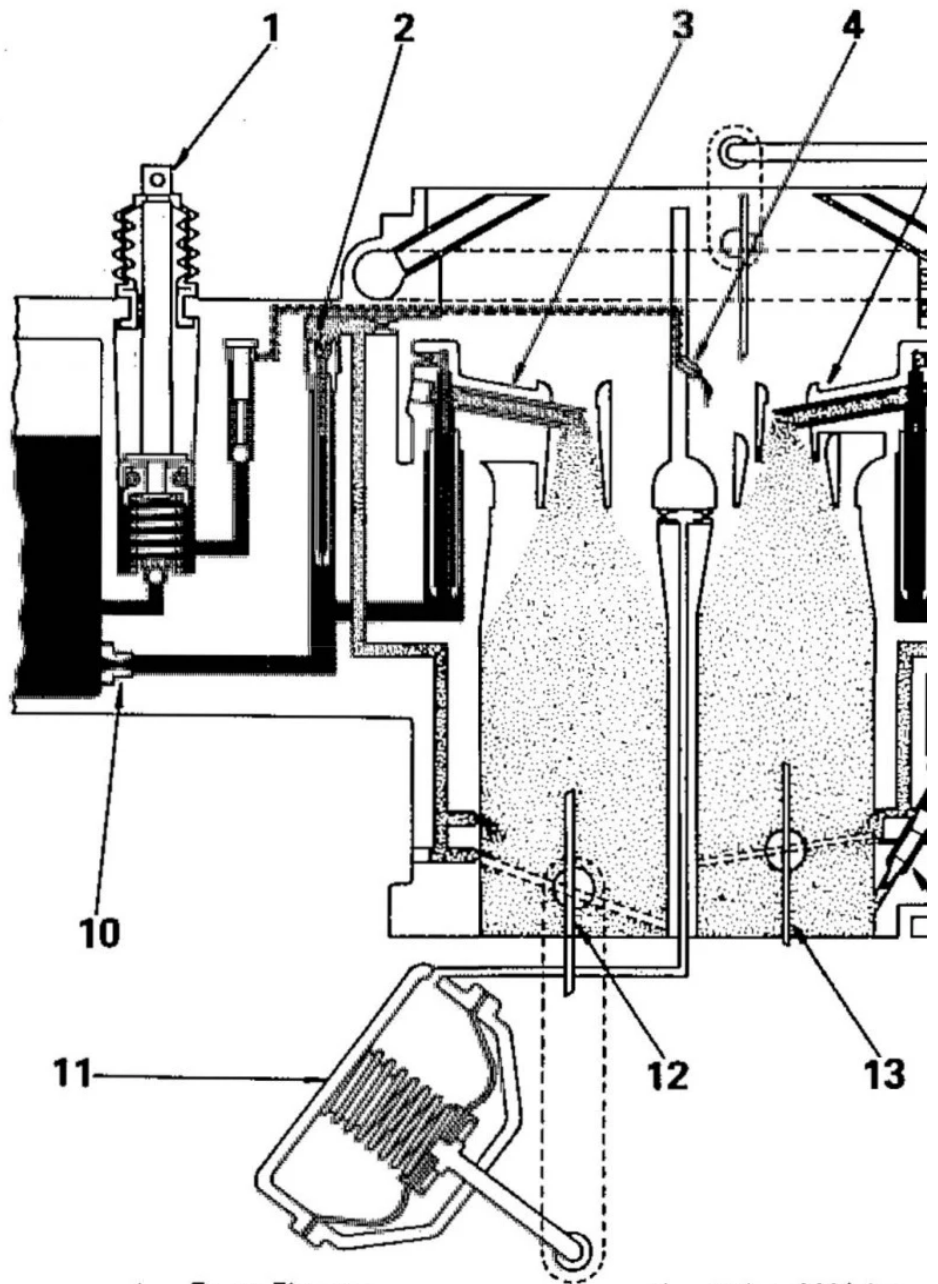

- | | | | |
|---|-----------------|----|------------------|
| 1 | Pump Plunger | 7 | Solenoid Valve |
| 2 | 2nd Slow Jet | 8 | Power Piston |
| 3 | 2nd Main Nozzle | 9 | Needle Valve |
| 4 | Pump Jet | 10 | 2nd Main Jet |
| 5 | 1st Main Nozzle | 11 | Diaphragm |
| 6 | Choke Breaker | 12 | 2nd Throttle Val |

CARBURETOR

CARBURETOR CIRCUITS (Except for USA)

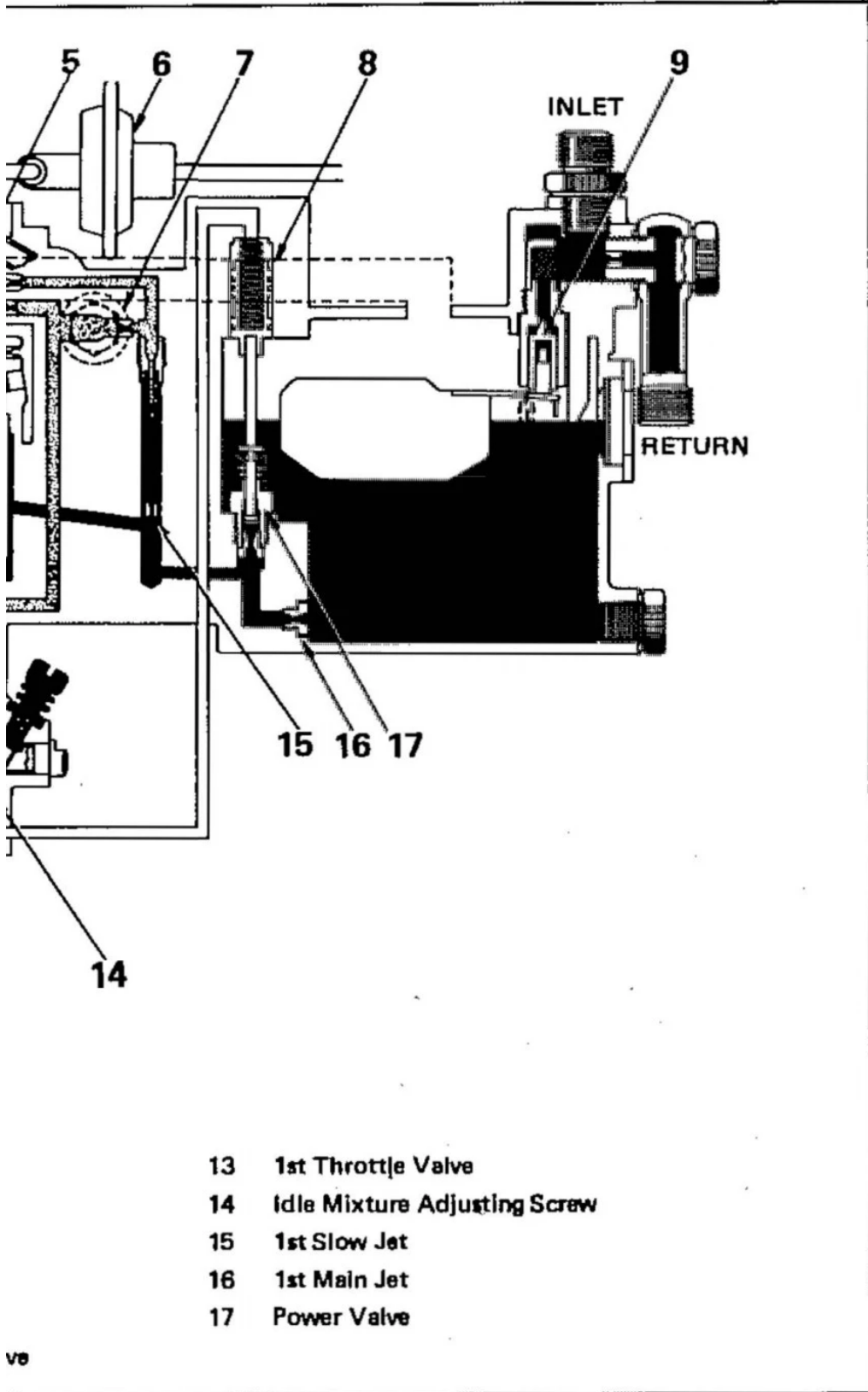

- 13 1st Throttle Valve
- 14 Idle Mixture Adjusting Screw
- 15 1st Slow Jet
- 16 1st Main Jet
- 17 Power Valve

vs

Fig. 6-11

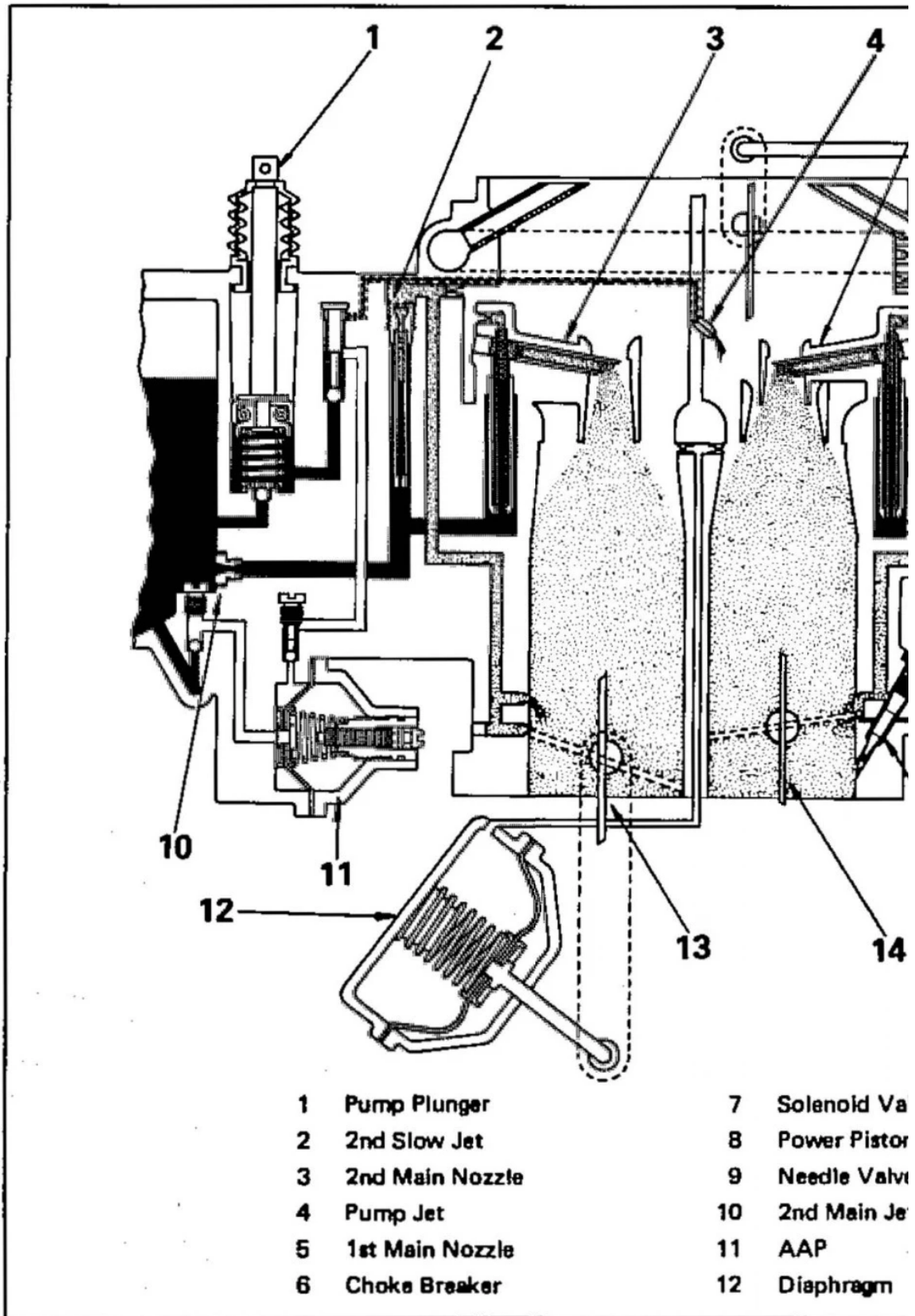

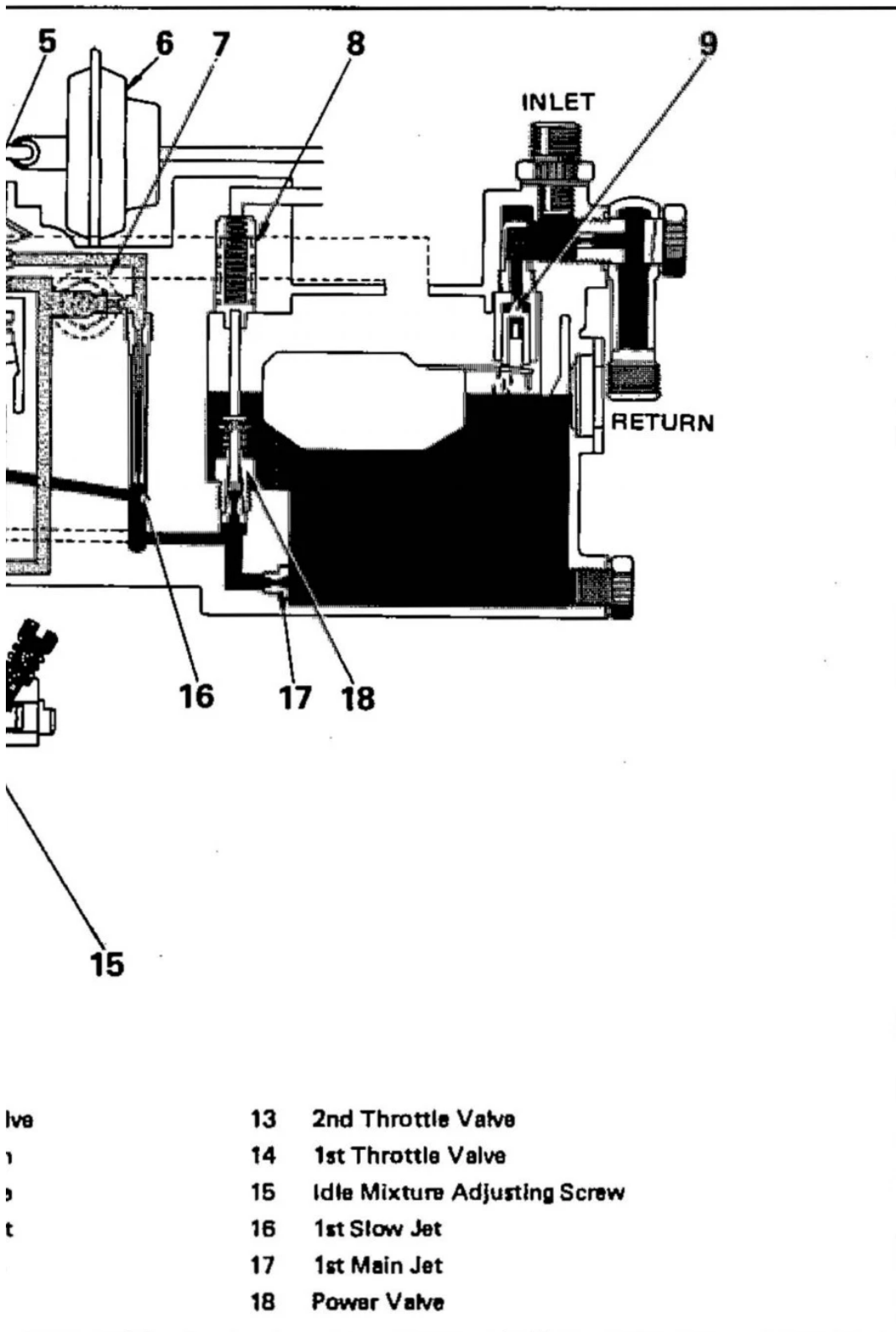

- 13 2nd Throttle Valve
- 14 1st Throttle Valve
- 15 Idle Mixture Adjusting Screw
- 16 1st Slow Jet
- 17 1st Main Jet
- 18 Power Valve

DISASSEMBLY

Disassemble in numerical order.

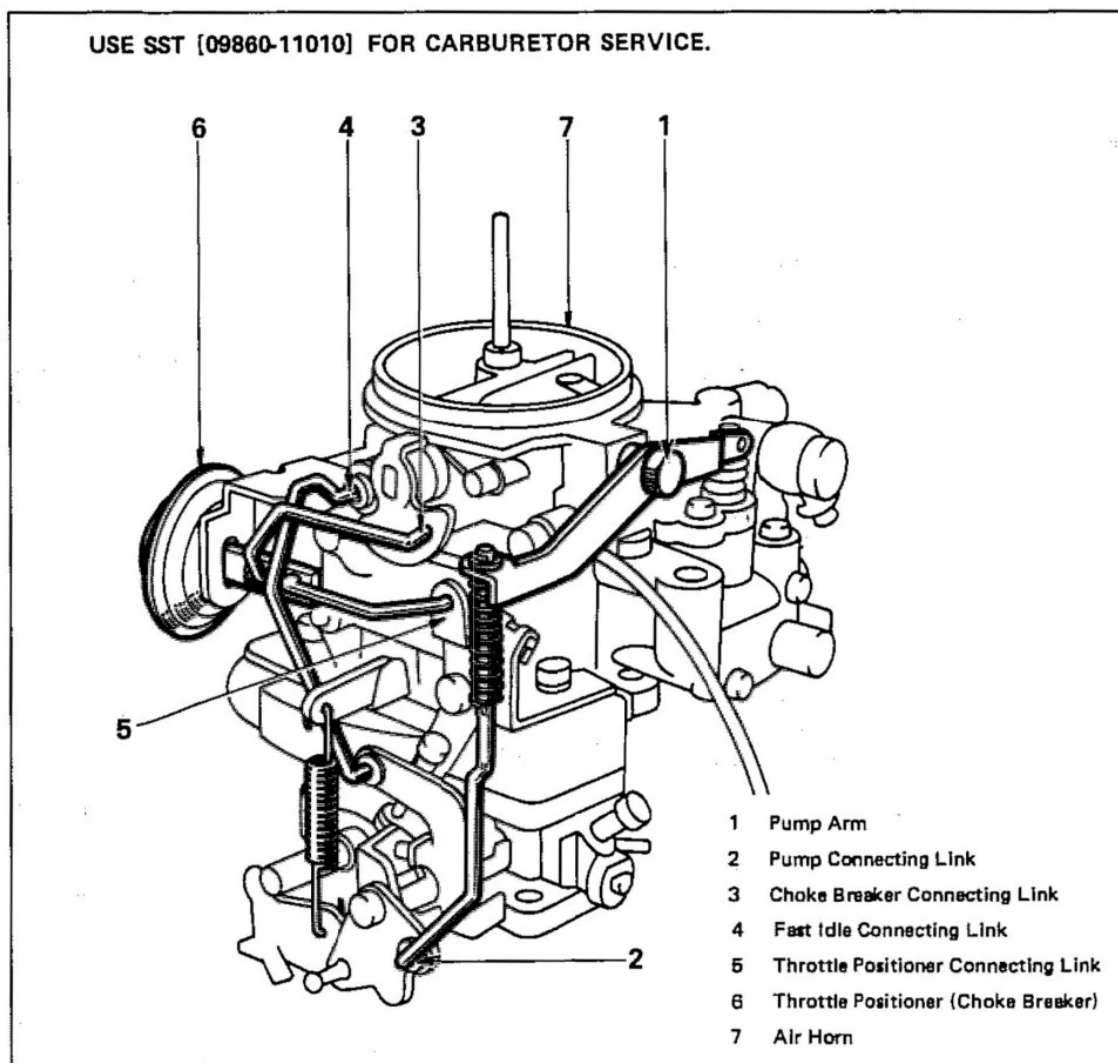
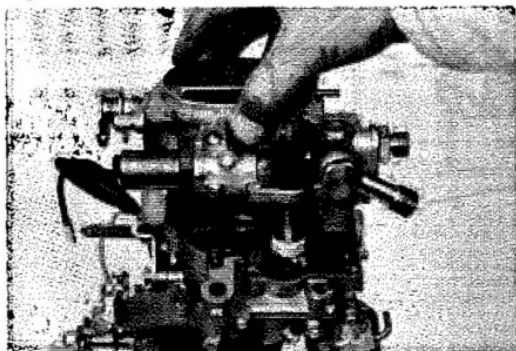

Fig. 6-12

Fig. 6-13



Lift out air horn.

AIR HORN

Disassemble in numerical order.

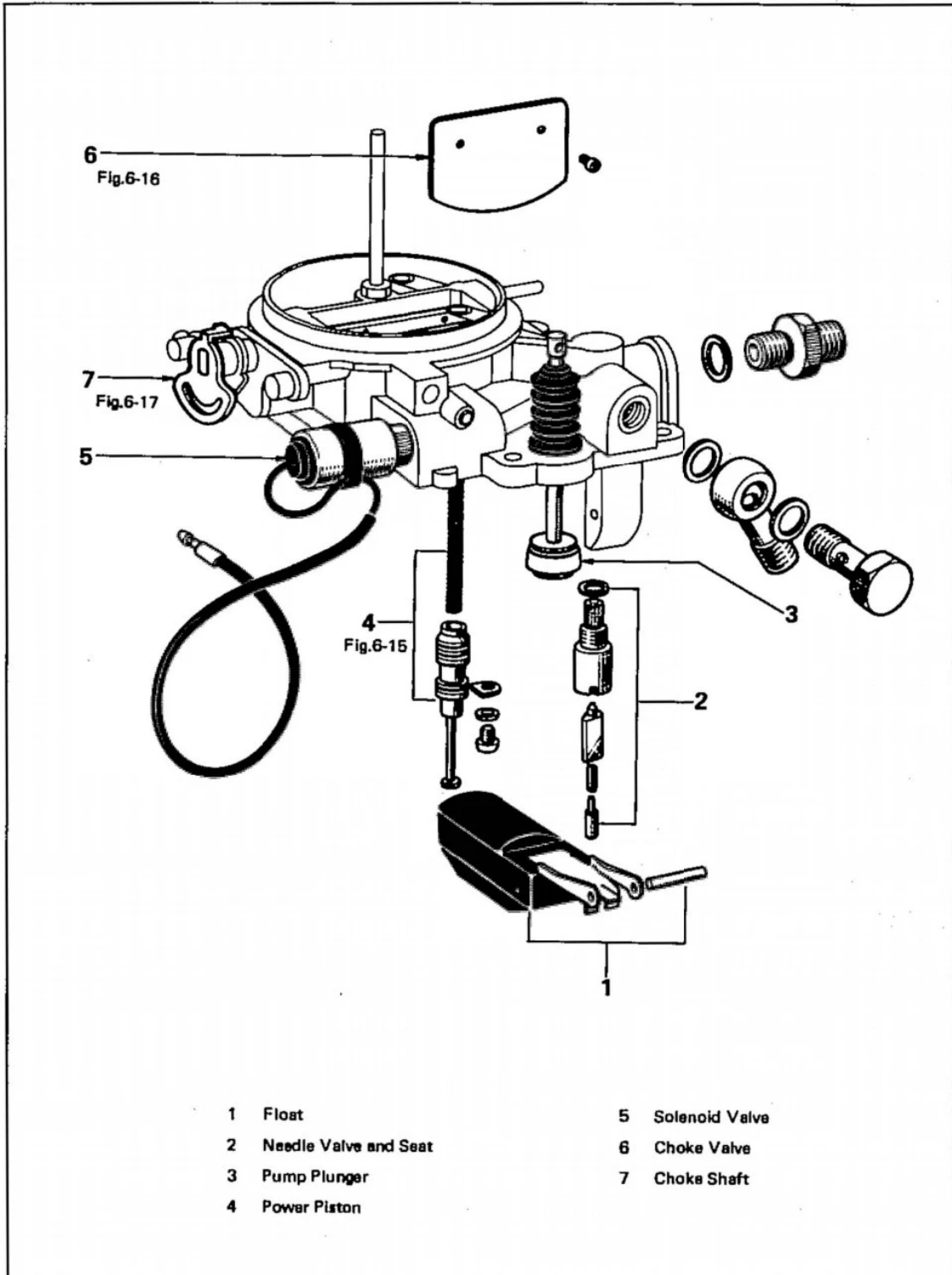
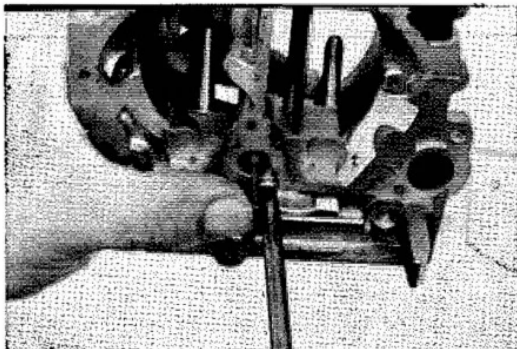

Fig. 6-14

Fig. 6-15



Remove power piston and spring. Take care not to lose the spring.

Fig. 6-16

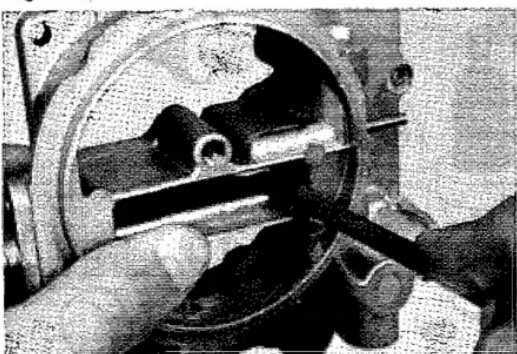

Unpeen set screws and remove choke valve.

Fig. 6-17



Unhook spring and pull out choke shaft.

BODY

Disassemble in numerical order.

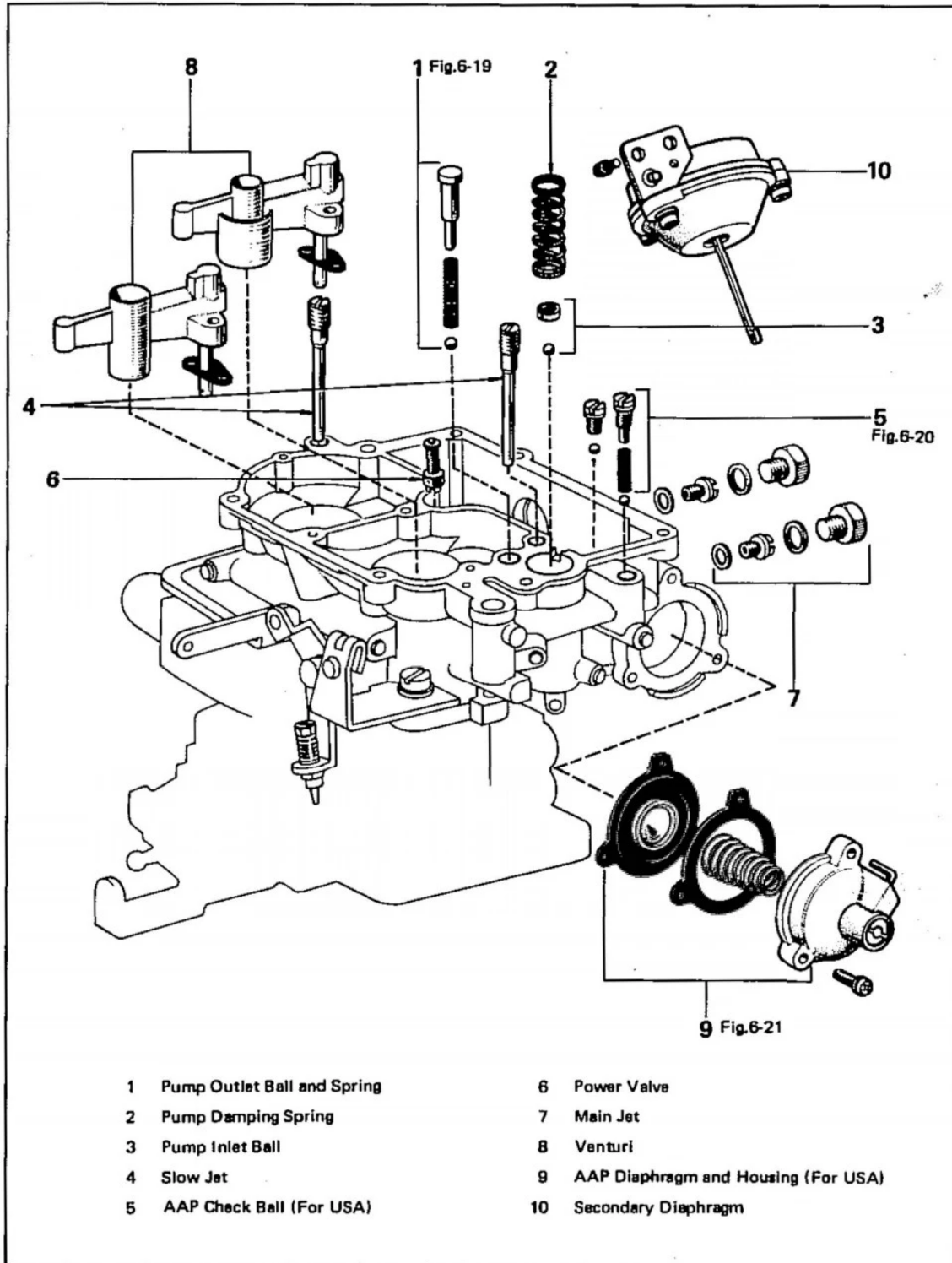
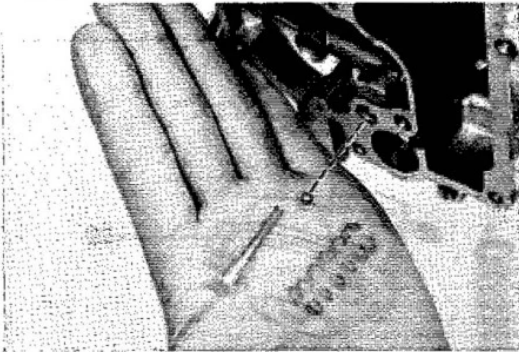

Fig. 6-18

Fig. 6-19



Drop out pump outlet ball and springs.

Fig. 6-20

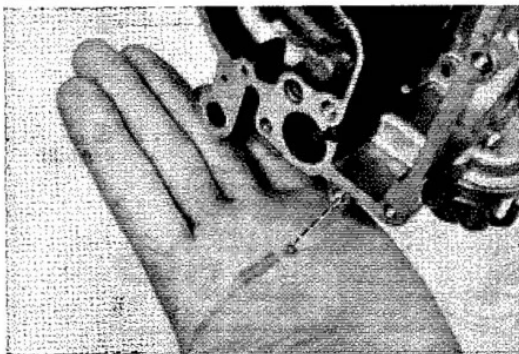

Loosen screw plug and drop out AAP outlet ball and spring.

Fig. 6-21

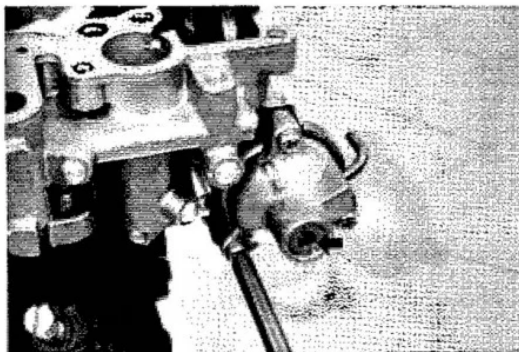

Remove AAP housing and diaphragm.
Do not turn the AAP adjusting screw (Arrow).

INSPECTION**– Precaution –**

1. Before inspecting the parts, wash them thoroughly in carburetor cleaner. Using compressed air, blow all dirt and other foreign matter from the jets and similar parts, and from the fuel passages and restrictions in the body.
2. Never clean the jets or orifices with wire or a drill. This could enlarge the openings and result in excessive fuel consumption.

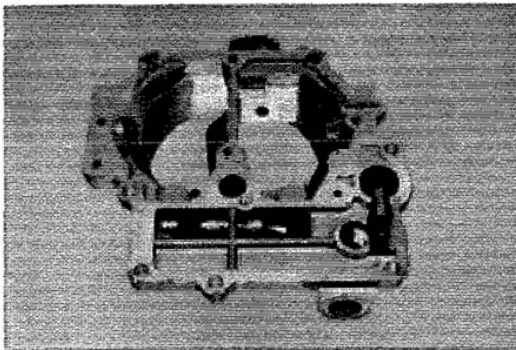
Fig. 6-22

Inspect the following parts and replace any part damaged.

Air Horn Parts

1. Air horn: Cracks, damaged threads, and wear on choke shaft bores.

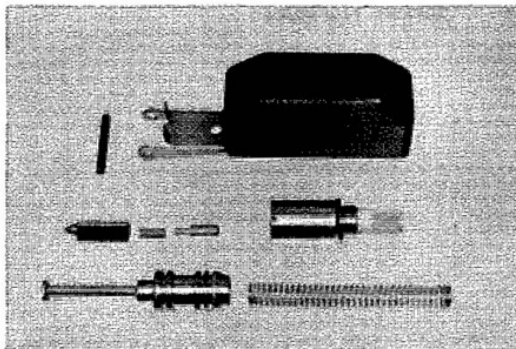
Fig. 6-23

2. Float: Broken lip, wear in float pivot pin holes.
3. Needle valve surface contacting valve seat.
4. Strainer: Rust, breaks.
5. Power piston: Scratches, excessive wear. Power piston spring broken or deformed.

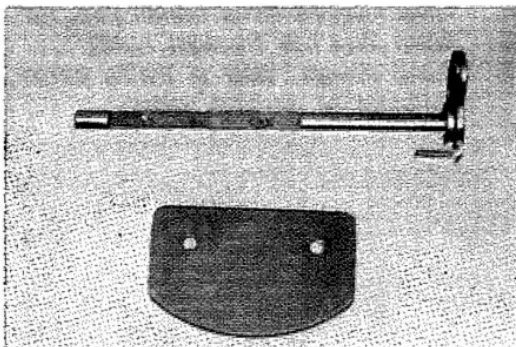
Fig. 6-24

6. Choke valve: Deformation. Choke shaft worn, bent, or not fitting properly into housing.

Fig. 6-25

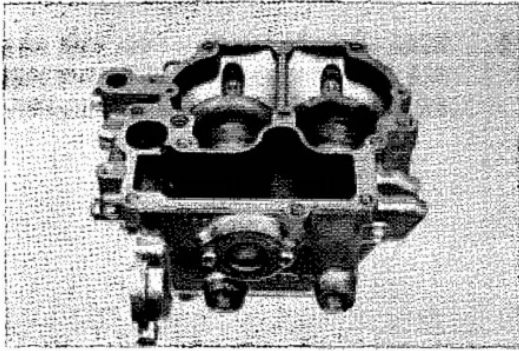
**Body Parts**

1. Body: Cracks, scored mounting surfaces, damaged threads.

Fig. 6-26

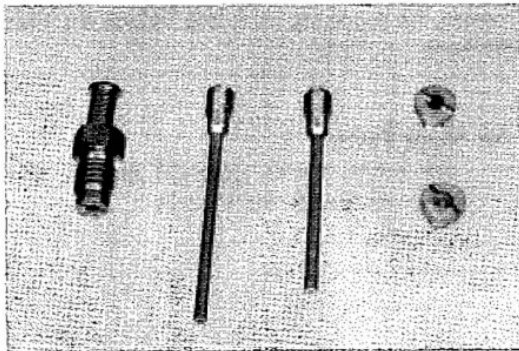

2. Jets: Damaged contacting surface, damaged threads and screwdriver slots.
3. Power valve: Faulty opening and closing action, damaged contacting surface and threads.

Fig. 6-27

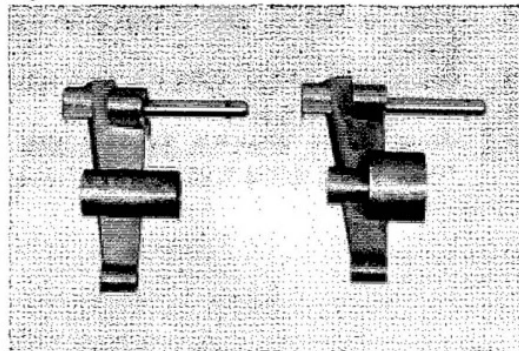

4. Venturi: Damaged.

Fig. 6-28

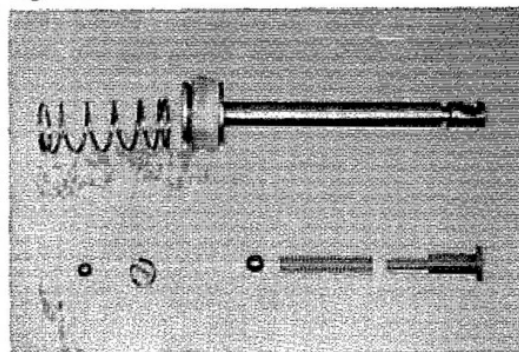

5. Pump damping spring: Deformation, rust.
6. Pump check ball: Damaged, rusted.
7. Pump plunger: Wear at sliding surface, deformed or damaged leather.

Fig. 6-29

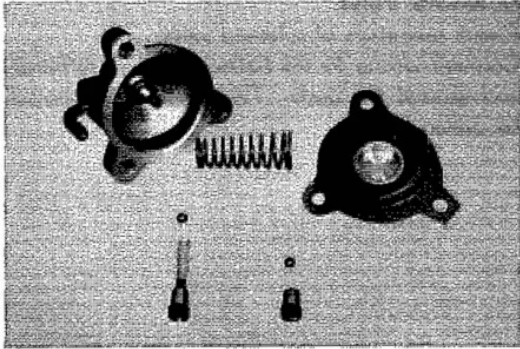

- 8. AAP check ball: Faulty opening and closing action or damaged diaphragm.

Fig. 6-30

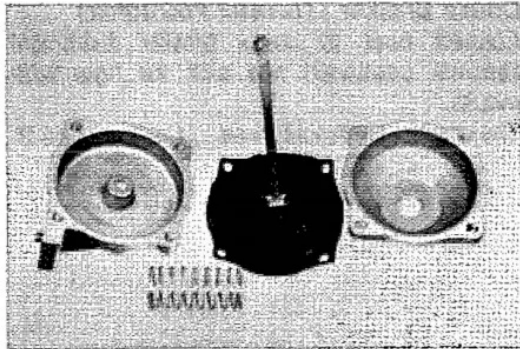

- 9. Secondary diaphragm: Damaged.

Fig. 6-31

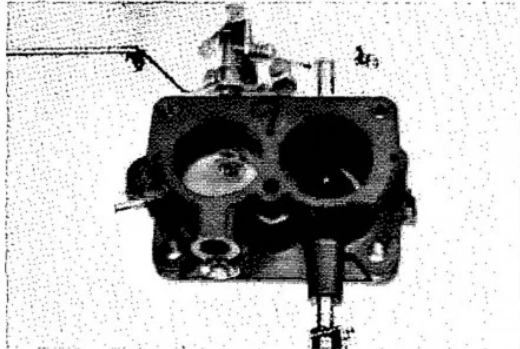

Flange Parts

- 1. Flange: Cracks, injured mounting surfaces, damaged threads, wear at throttle shaft bearings.
- 2. Throttle valves: Wear or deformation in valves. Wear, bending, twisting, or faulty movement inside housing of shaft.

Fig. 6-32

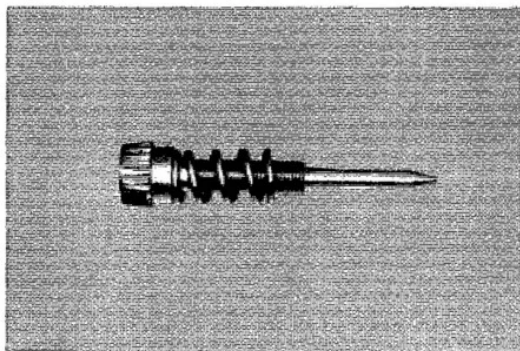

- 3. Idle mixture adjusting screw: Damage at tapered tip or threads.

Fig. 6-33

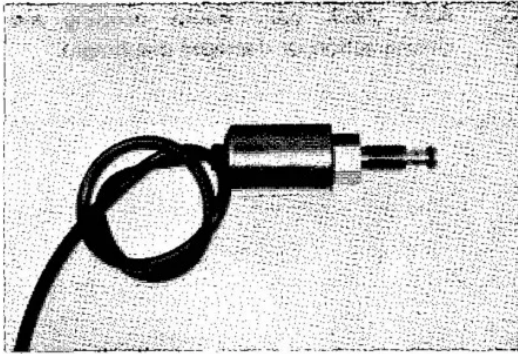
**Solenoid Valve**

Check operation of solenoid valve.

Connect wiring to the battery positive terminal and ground the body. The needle valve should be pulled in.

Fig. 6-34

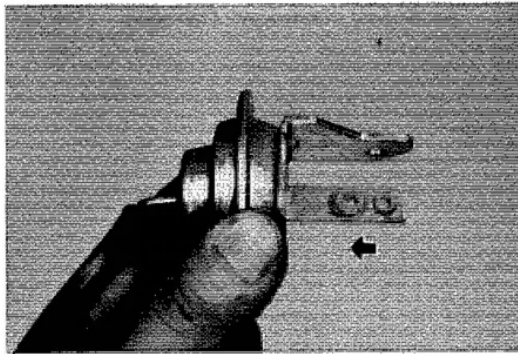
**Choke Breaker (Throttle Positioner)**

Connect hose to choke breaker diaphragm (throttle positioner) and suck the hose with mouth.

The diaphragm should move. If not, replace it.

ASSEMBLY

AIR HORN

Assemble in numerical order.

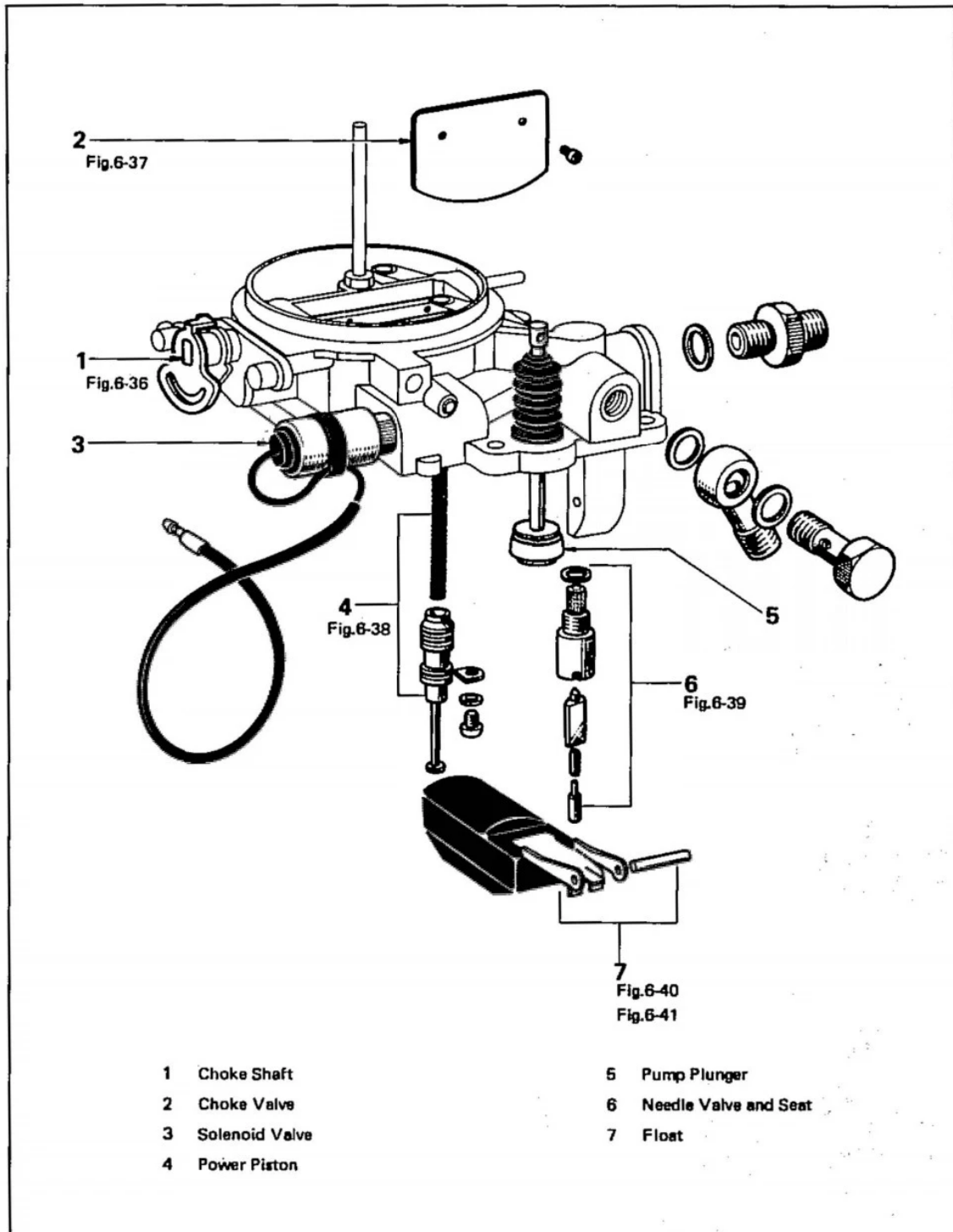
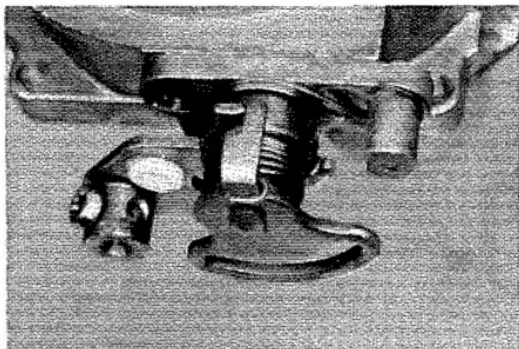

Fig. 6-35

Fig. 6-36



Insert choke shaft and hook the spring as shown.

Fig. 6-37

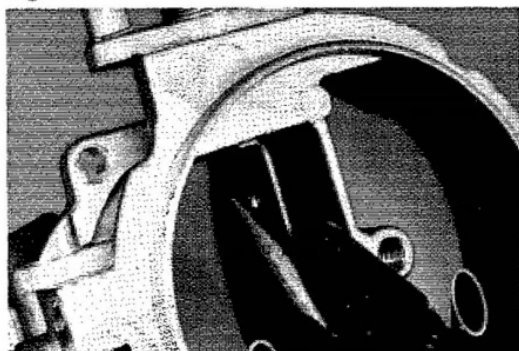

Install choke valve, then peen screws.

Fig. 6-38

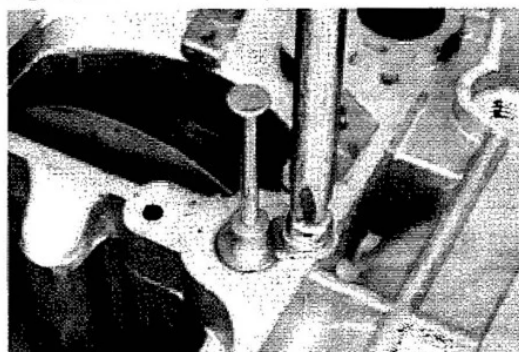

Install power piston and spring.
Make sure that the piston moves smoothly.

Fig. 6-39

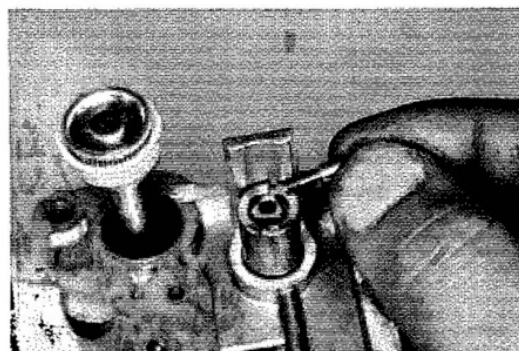

Fit needle valve, spring and plunger in order.

Fig. 6-40

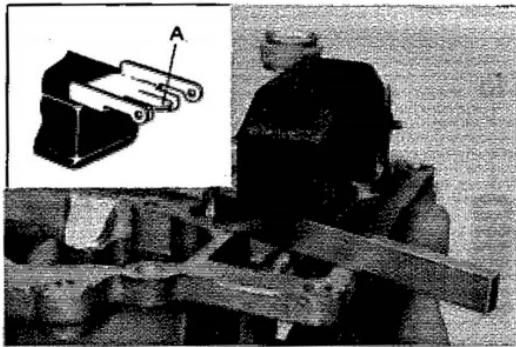

Adjust float level.

Allow the float to hang down by its own weight. Then check the clearance between the float tip and air horn with SST [09240-00013]. Adjust by bending the (A) part of float lip.

Standard **7.5 mm (0.295 in)**

– Note –

This measurement is always made without any gasket on air horn.

Fig. 6-41

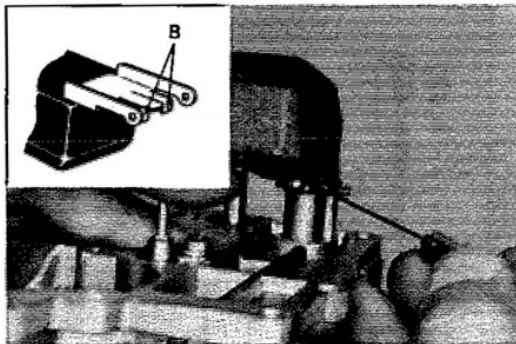

Adjust lowered position.

Lift up the float and check the clearance between the needle valve plunger and float lip with SST [09240-00011]. Adjust by bending the (B) part of float lip.

Standard **1.1 mm (0.043 in)**

BODY

Assemble in numerical order.

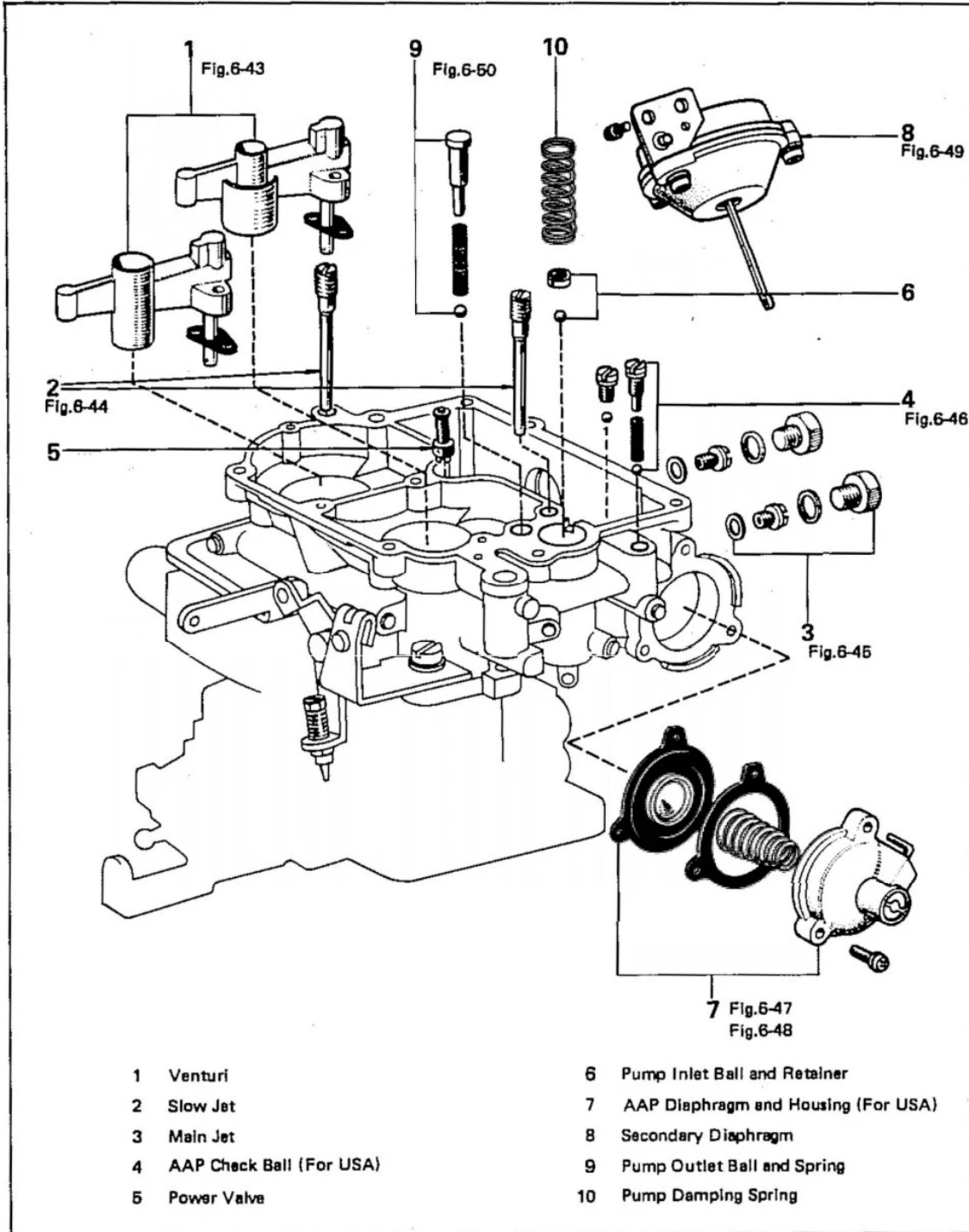
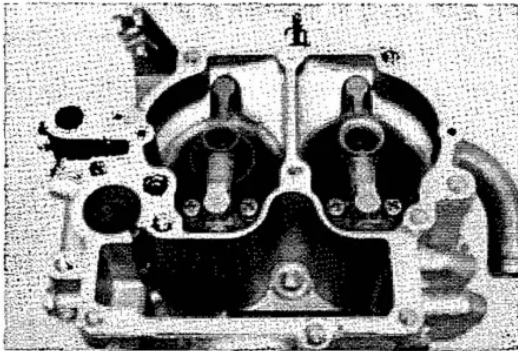

Fig. 6-42

Fig. 6-43



Install venturis over gasket.
 Primary and secondary venturis are different.
Primary ——— **Triple venturi**
Secondary ——— **Double venturi**

Fig. 6-44

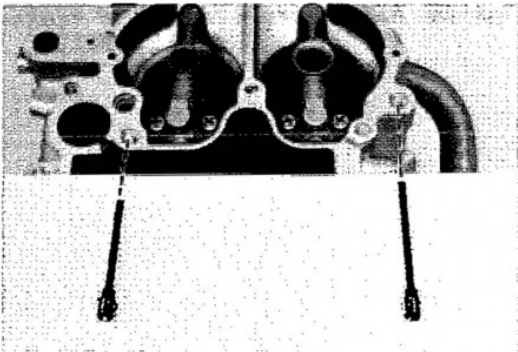

Install slow jets.
 Longer or larger size jet should be installed at secondary side.

Fig. 6-45

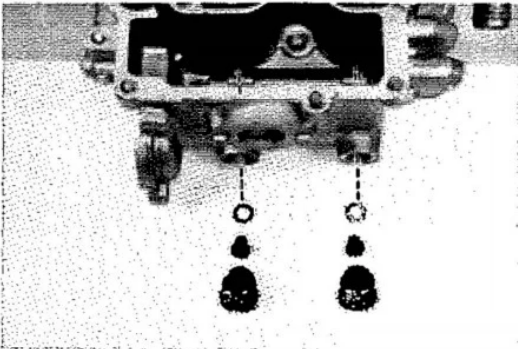

Install main jets over gasket.
Primary jet ——— **Brass colored**
Secondary jet ——— **Chrome colored**

Fig. 6-46

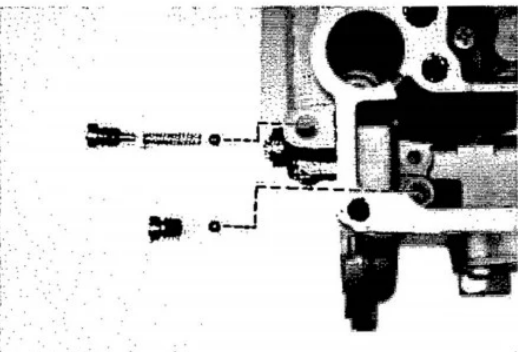

Install AAP check balls.
 — Note —
 There are two sizes of balls.
Smaller ball: For AAP and pump inlet
Larger ball: For Pump outlet

Fig. 6-47

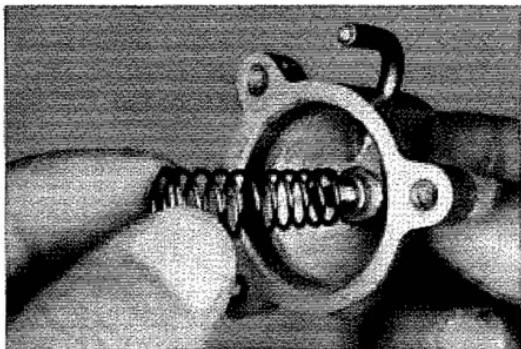

Fit AAP spring in direction as shown.

Fig. 6-48

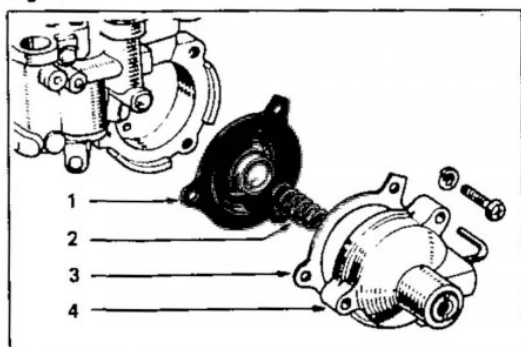

Assemble AAP diaphragm in order as shown.

Fig. 6-49

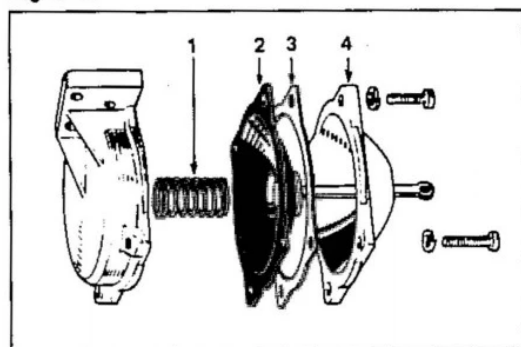

Assemble secondary diaphragm in order as shown.

Fig. 6-50

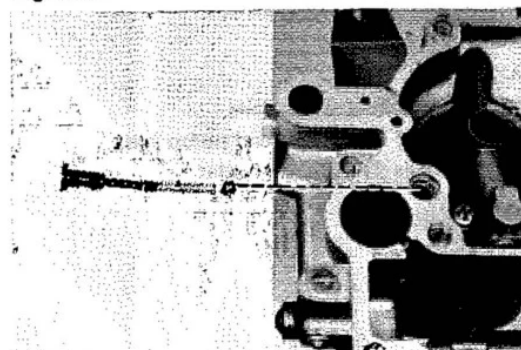

Install pump outlet ball and spring.

BODY AND AIR HORN

Assemble in numerical order.

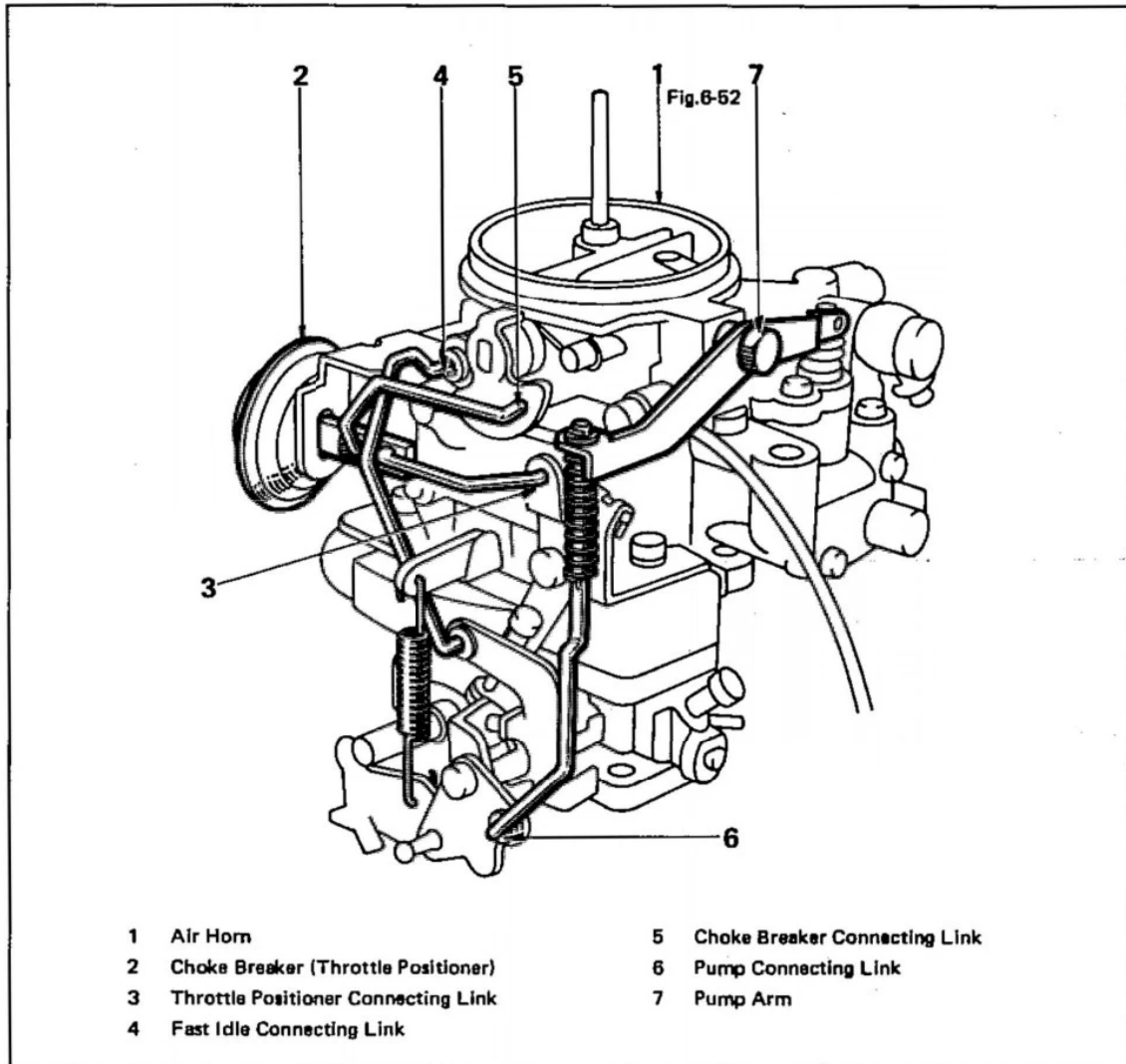
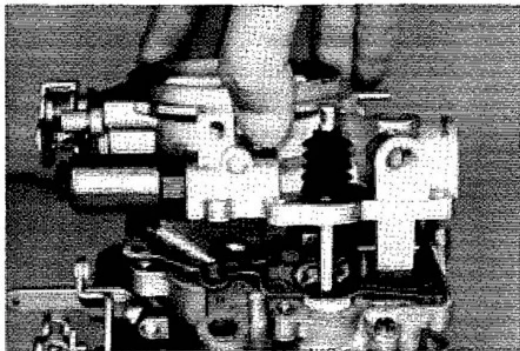

Fig. 6-51

Fig. 6-52



Assemble body and air horn over new gasket. Take care not to damage pump plunger leather.

Fig. 6-53

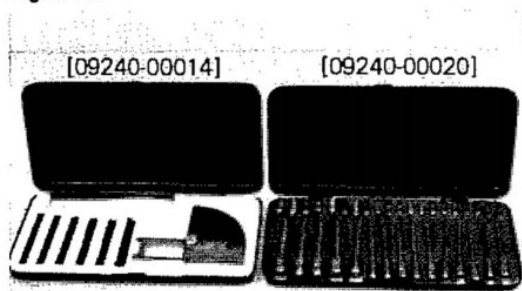
**ADJUSTMENT**

Use SST [09240-00014] and [09240-00020] to make adjustments.

Fig. 6-54

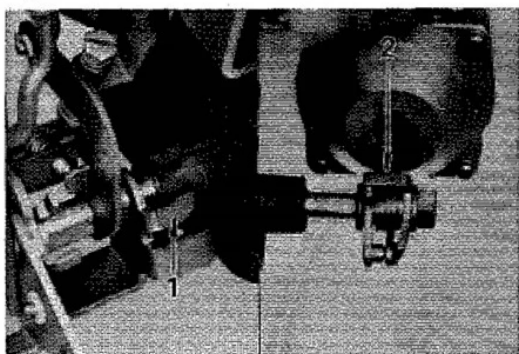

1. Throttle valve openings
Open the primary and secondary throttle valves separately and check if the throttle valves will be perpendicular to the flange surface when fully opened. Adjust by bending the respective throttle lever stoppers at the primary (1) and secondary sides (2).

Fig. 6-55

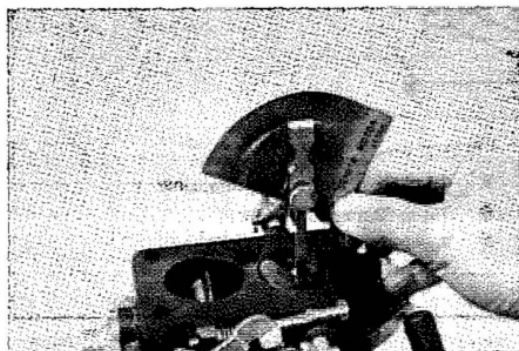

2. Kick up
With the primary throttle valve fully opened, check the secondary throttle valve opening. Adjust by bending secondary throttle lever.
Standard 28° from bore
25° from bore
(Only for California)

Fig. 6-56

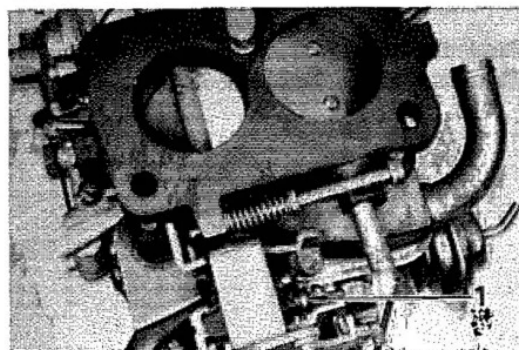

3. Fast idle
With choke valve fully closed, check the clearance between bore and primary throttle valve. Adjust by turning fast idle adjusting screw (1).
Standard clearance 1.3 mm (0.051 in)

Fig. 6-57

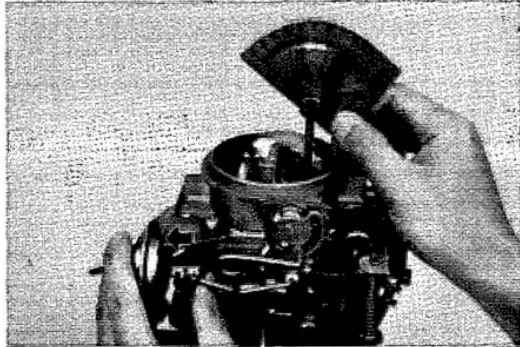

4. Choke breaker
 Push in choke breaker rod to open choke valve and check the choke valve angle. Adjust by bending the choke breaker link.
Standard 38° from bore

Fig. 6-58

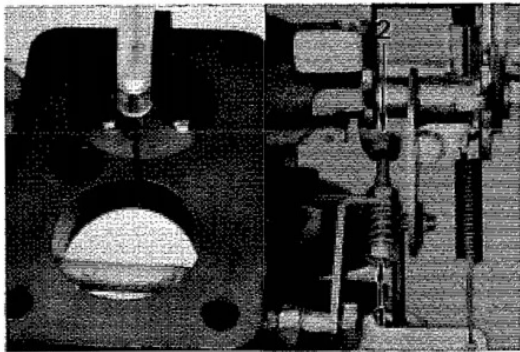

5. Throttle positioner
 Contact throttle positioner adjusting screw (1) to throttle lever tab (2), check the clearance between bore and primary throttle valve. Adjust by turning the adjusting screw.
Standard clearance 0.8 mm (0.031 in)

Fig. 6-59

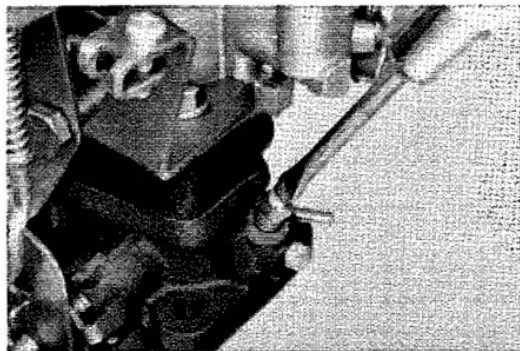

6. Idle mixture adjusting screw
 Screw in the idle mixture adjusting screw and then unscrew it by the following amount.
**Standard (Reference only)
 Returned about 1½ turns from full closed**

— Caution —
 Take care not to screw in too tightly and damage the screw tip.

Fig. 6-60

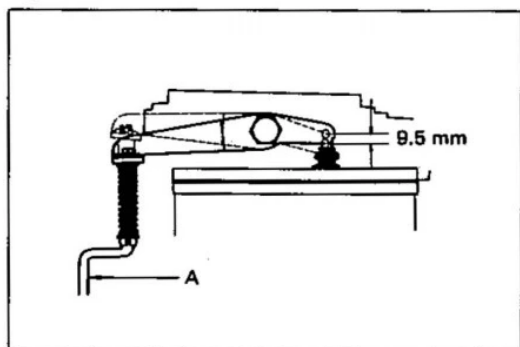

7. Accelerating pump
 Adjust the pump stroke by bending part A.
Standard 9.5 mm (0.374 in)

— Note —
 After adjustment is made, be sure to check the linkage to see that it operates smoothly.

MEMO

STARTING SYSTEM

| | Page |
|---------------------------------------|-------------|
| STARTING SYSTEM CIRCUITS | 7- 2 |
| STARTER | 7- 3 |
| DISASSEMBLY | 7- 3 |
| INSPECTION AND REPAIR | 7- 6 |
| ASSEMBLY..... | 7-13 |
| PERFORMANCE TEST..... | 7-17 |

STARTING SYSTEM CIRCUITS

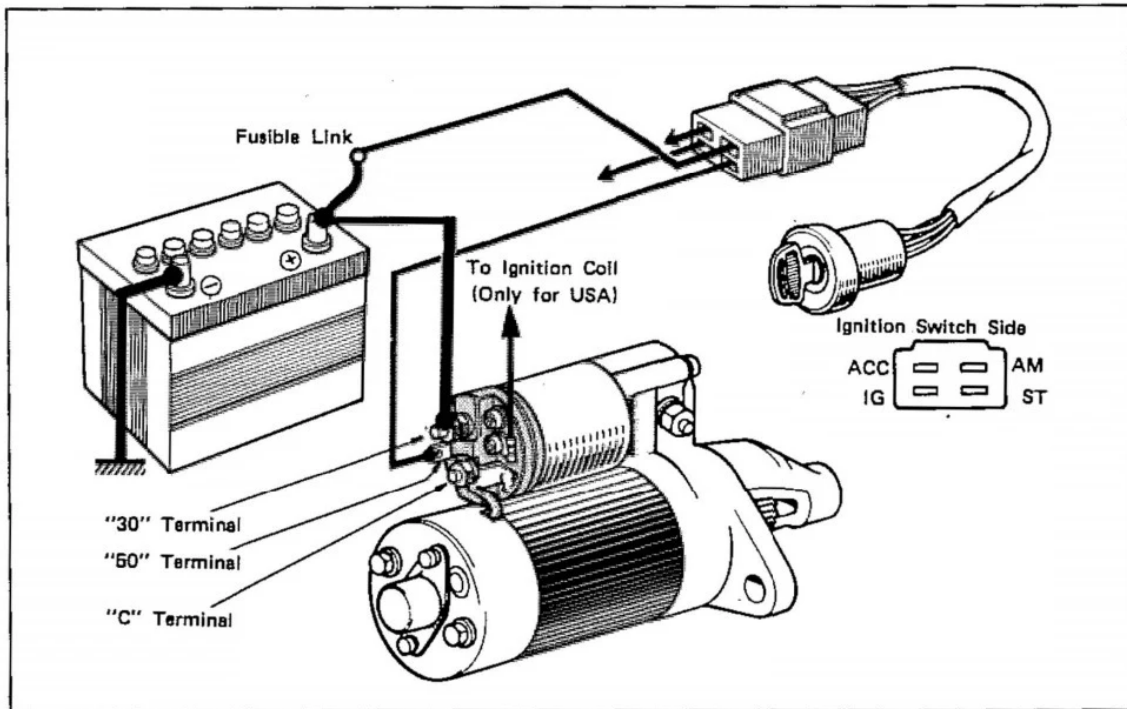

Fig. 7-1

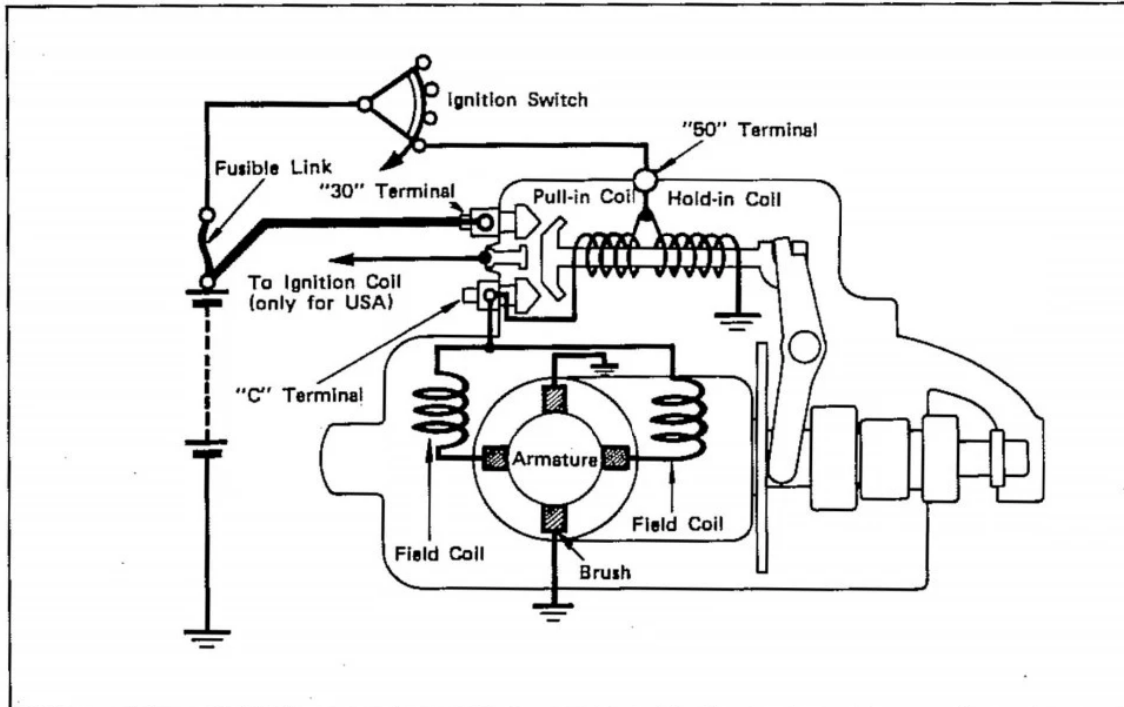

Fig. 7-2

STARTER

DISASSEMBLY

Disassemble in numerical order.

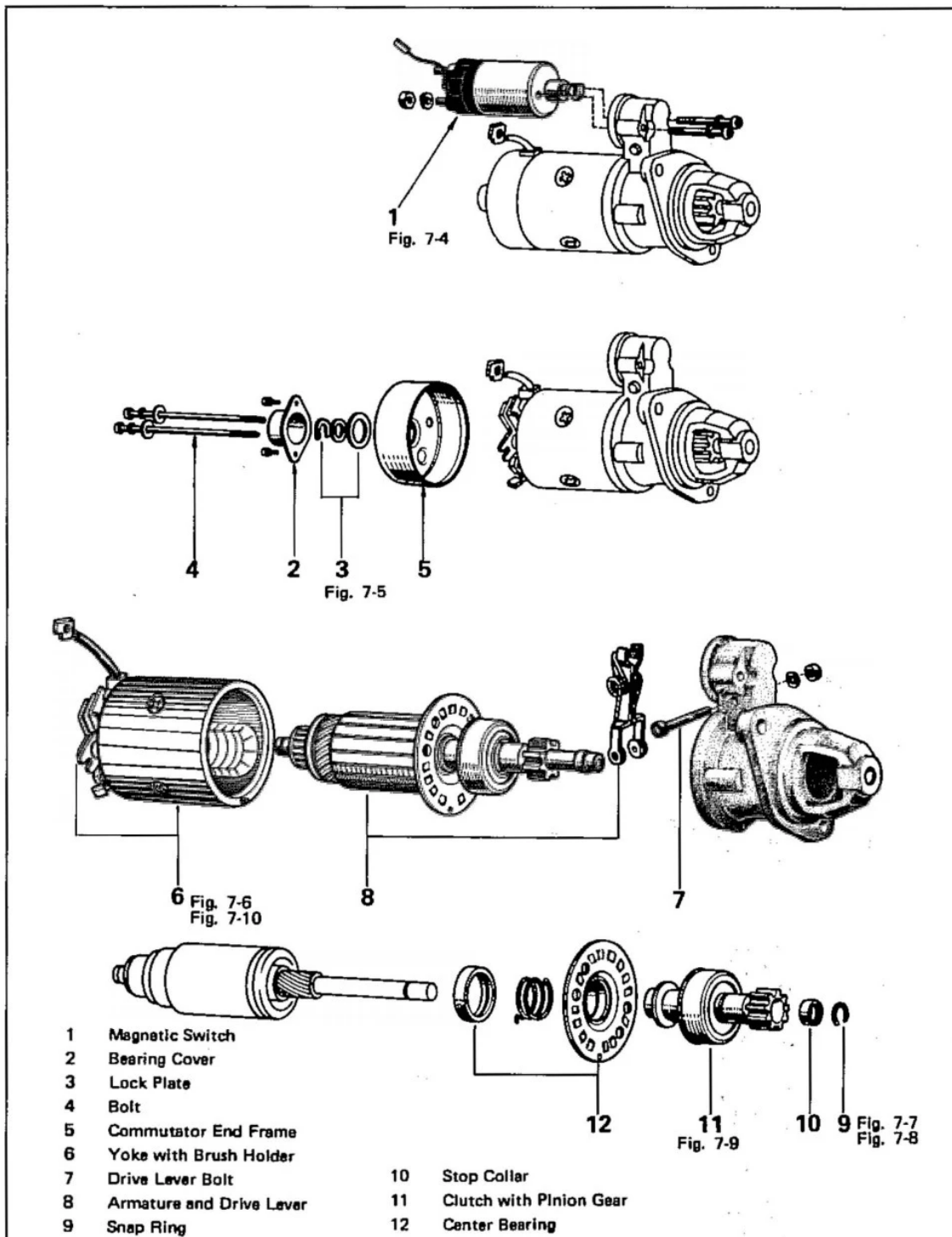

Fig. 7-3

Fig. 7-4



Disconnect lead wire before removing magnetic switch.

Fig. 7-5

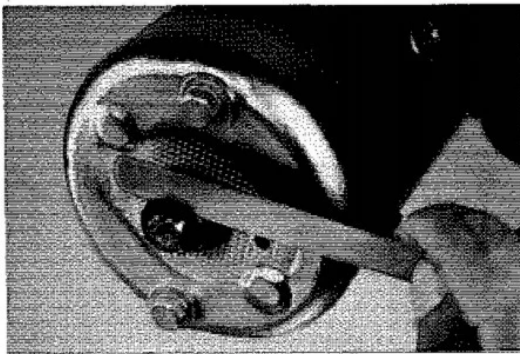

Check the armature shaft thrust clearance.

Thrust clearance **0.05-0.35 mm**
(0.002-0.0138 in)

Fig. 7-6

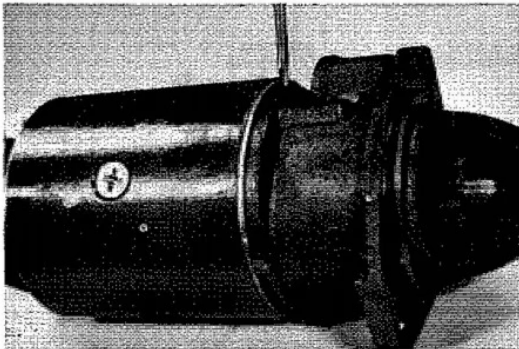

Pry off the yoke, using a screwdriver.

Fig. 7-7

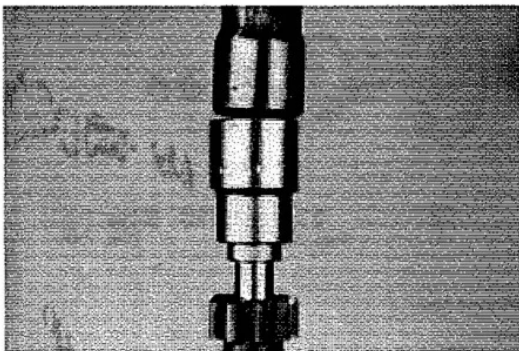

Tap in stop collar, using a socket wrench.

Fig. 7-8

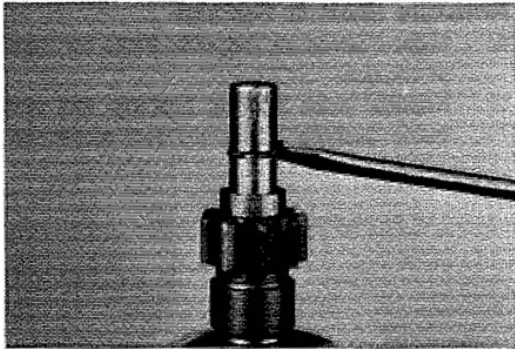

Pry the snap ring, using a screwdriver.

Fig. 7-9

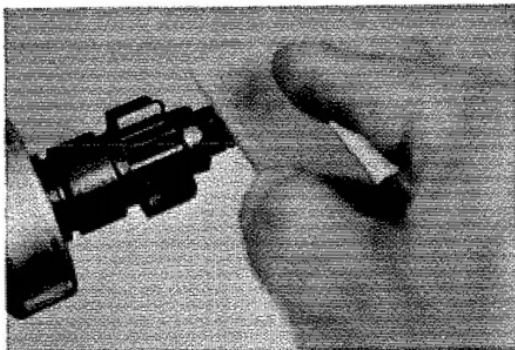

If difficult to pull out the pinion, repair the shaft with an oil stone.

Fig. 7-10

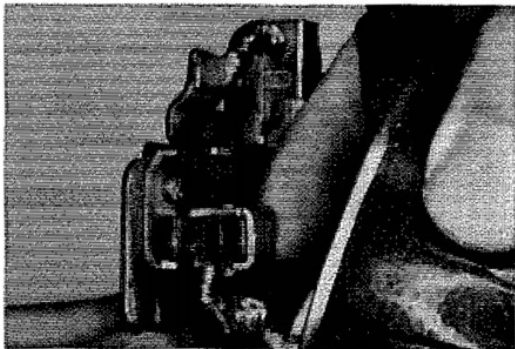

Take off brushes and remove brush holder.

Fig. 7-11

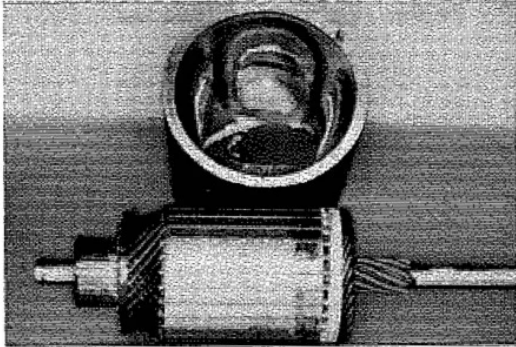

Fig. 7-12

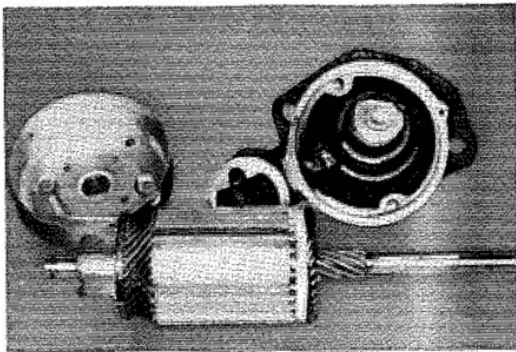

Fig. 7-13

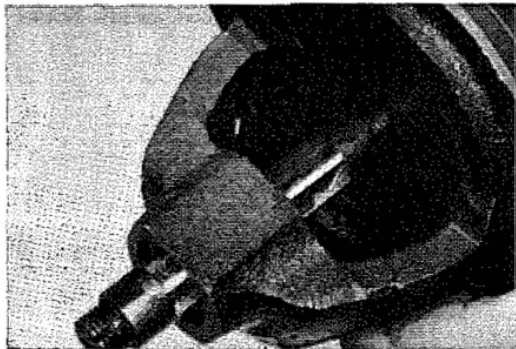

Fig. 7-14



INSPECTION AND REPAIR

Armature Shaft & Bearings



1. Inspect armature and pole shoes for signs of contact.

Replace drive housing bushing and end frame bushing if any contact suspected.



2. Inspect armature shaft end, drive housing bushing and end frame bushing for wear or damage.

Oil clearance limit

0.2 mm (0.008 in)

3. BUSHING REPLACEMENT

- (1) Pry out the bushing cover and press out the bushing.
- (2) Press in new bushing and ream to obtain the specified clearance.

Oil clearance

0.05 mm (0.0020 in)



- (3) Clean the bore, and install new bushing cover.

Fig. 7-15

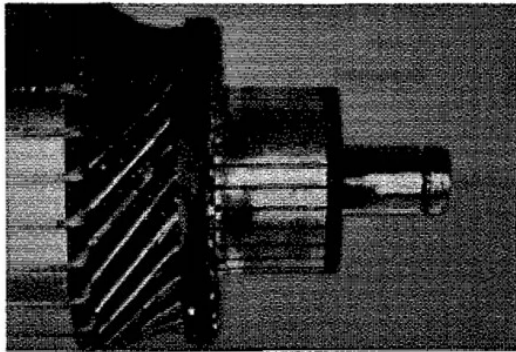

Commutator

Inspect for the following items and repair or replace.

1. Dirty or burnt surface.
Correct by sandpaper or lathe if necessary.

Fig. 7-16

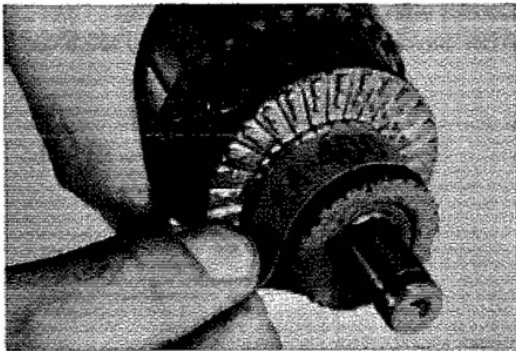

Use # 400 sandpaper.

Fig. 7-17

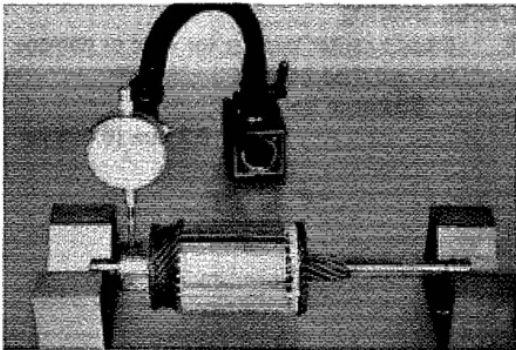

2. Runout: Correct on a lathe if it exceeds the limit.

| | |
|---------------------|----------------------------|
| Runout limit | 0.4 mm (0.016 in) |
| Standard | 0.05 mm (0.0020 in) |

Fig. 7-18

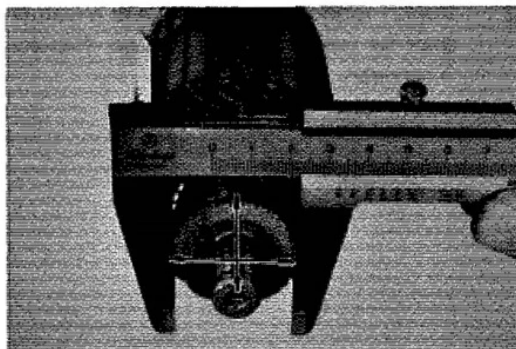

3. Surface wear: If below the limit, replace armature.

| | |
|-----------------|---------------------------|
| Limit | 31 mm (1.22 in) |
| Standard | 32.7 mm (1.287 in) |

Fig. 7-19

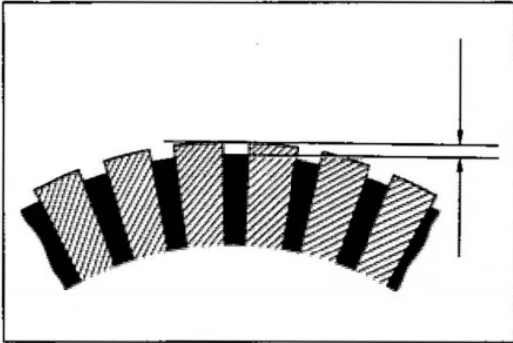

4. Depth of segment mica.
- | | |
|-----------------|--|
| Limit | 0.2 mm (0.008 in) |
| Standard | 0.5-0.8 mm (0.020-0.031 in) |

Fig. 7-20

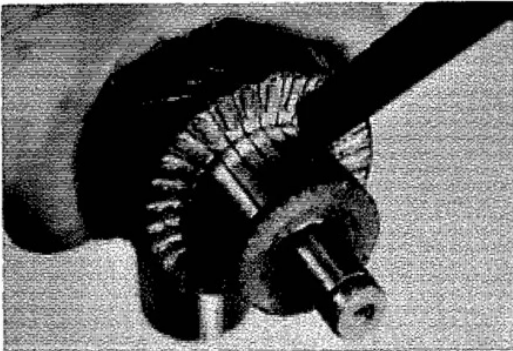

Correct with a hacksaw blade.
After correcting, eliminate chips using sandpaper.

Fig. 7-21

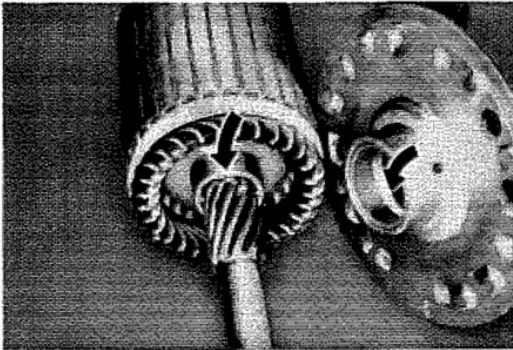

- Center Bearing**
1. Inspect center bearing for wear or damage. Replace if necessary.
Clearance limit
0.2 mm (0.008 in)

Fig. 7-22

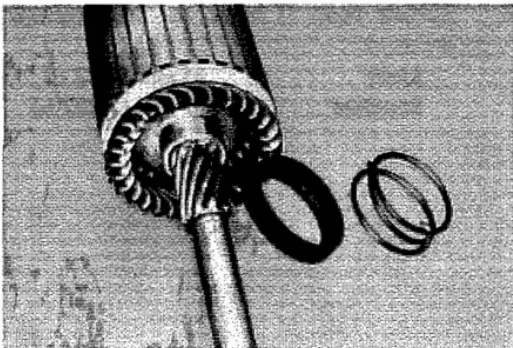

2. Inspect spring holder, spring and armature shaft for cracks, wear or damage. Replace if necessary.

Fig. 7-23

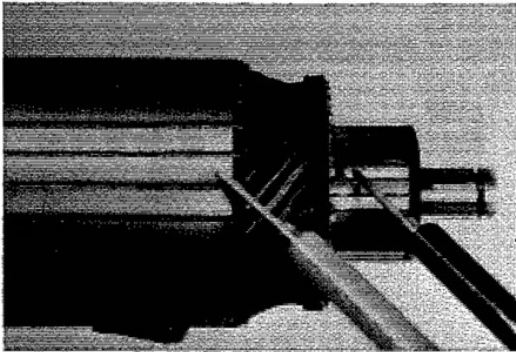
**Armature Coil**

1. Ground test
Check commutator and armature coil core. If there is continuity, the armature is grounded and must be replaced.

Fig. 7-24

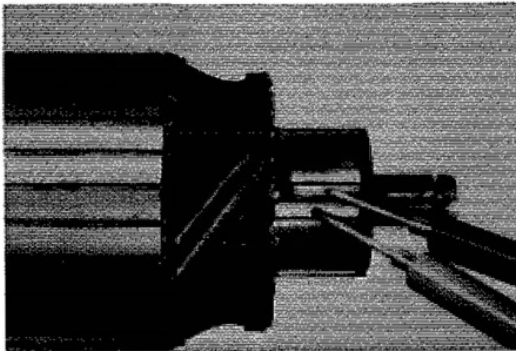

2. Open-circuit test
Check for continuity between the segments. If there is no continuity at any test point, there is an open-circuit and armature must be replaced.

Fig. 7-25

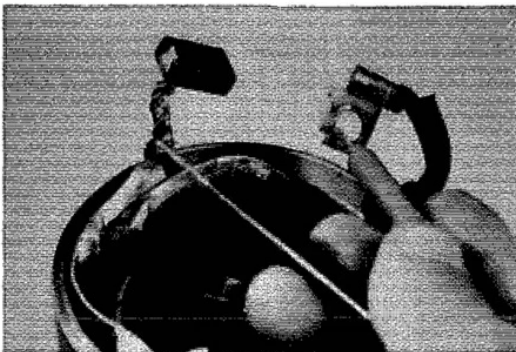
**Field Coil**

1. Open-circuit test
Check for continuity between the lead wire and field coil brush soldered connection. If there is no continuity, there is an open-circuit in the field coil, and it should be replaced.

Fig. 7-26

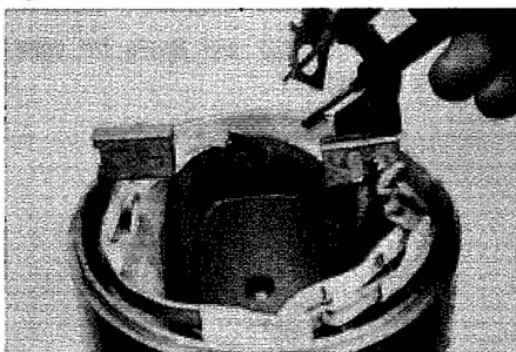

2. Ground test
Check for continuity between field coil end and field frame. If there is continuity, repair or replace the field coil.

Fig. 7-27

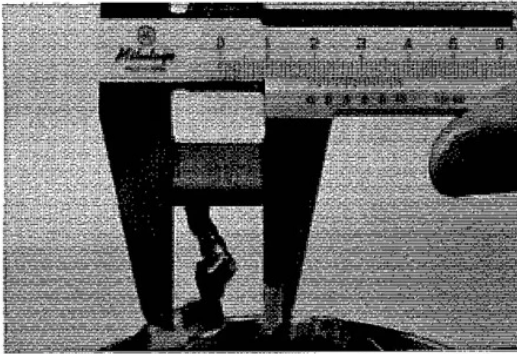
**Brushes**

Measure the brush length and replace if below the limit.

Limit

13 mm (0.51 in)

Standard

19 mm (0.75 in)

Fig. 7-28

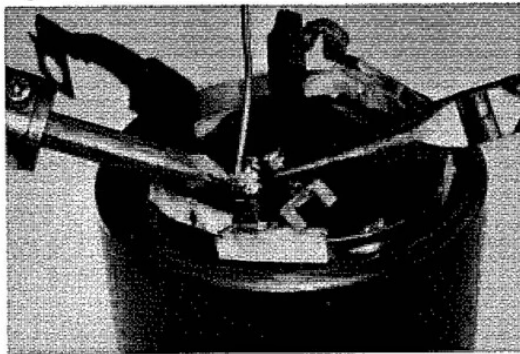
**Brush Replacement**

Solder brush lead firmly.

Fig. 7-29

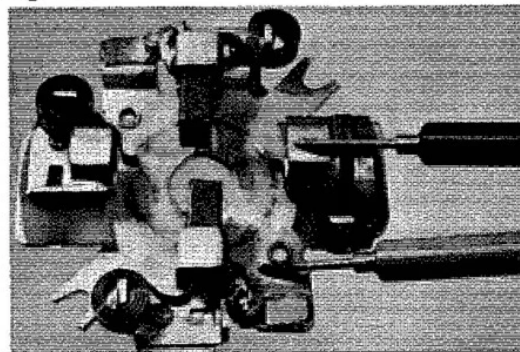
**Brush Holder**

Check insulation between the (-) brush holder and (+) brush holder. Repair or replace if continuity is indicated.

Fig. 7-30

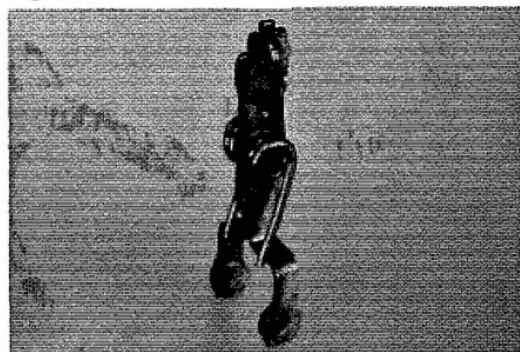
**Drive Lever**

Inspect the drive lever and spring for wear. Replace if necessary.

Fig. 7-31

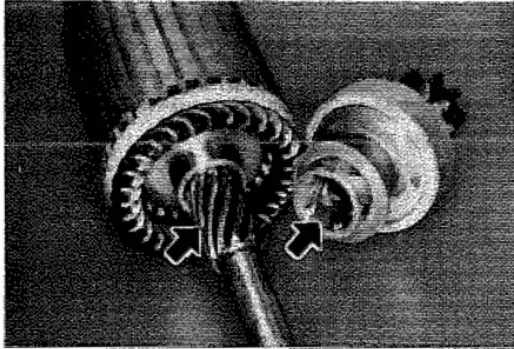

Starter Clutch and Pinion Gear

1. Inspect spline teeth for wear and damage. Replace if necessary.
2. Inspect pinion for smooth movement.

Fig. 7-32

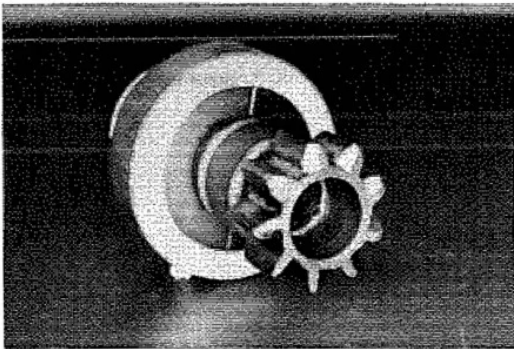

3. Inspect pinion gear teeth and chamfer if worn or damaged.

Fig. 7-33



4. Rotate pinion. It should turn free in clockwise direction and lock when turned counterclockwise.

Fig. 7-34

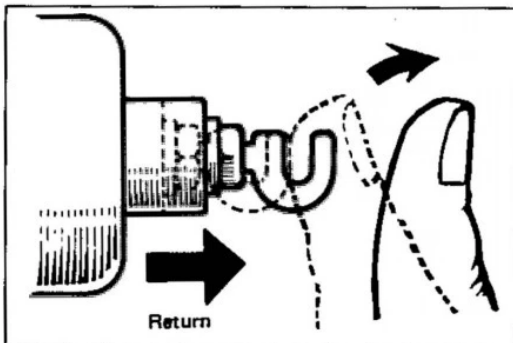

Magnetic Switch

1. Push in plunger and release it. The plunger should return quickly to its original position.

Fig. 7-35

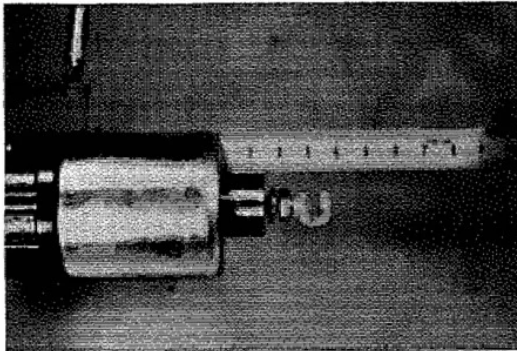

2. Measure distance from switch mounting surface to stud end.

Standard approx. 34 mm (1.34 in)

To adjust, loosen the lock nut and screw stud in or out.

Fig. 7-36

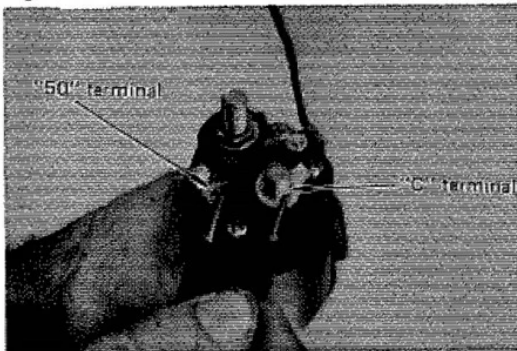

3. Pull-in coil open circuit test.
Check for continuity between the "50" terminal and "C" terminal.

Fig. 7-37

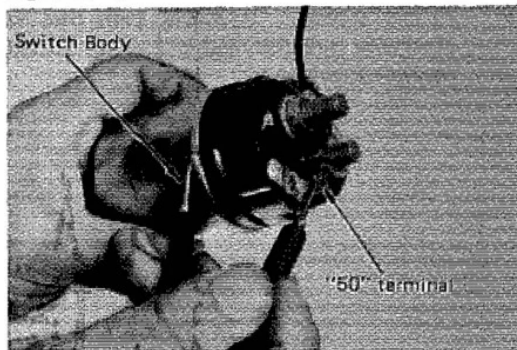

4. Hold-in coil open circuit test.
Check for continuity between the "50" terminal and switch body.

Fig. 7-38

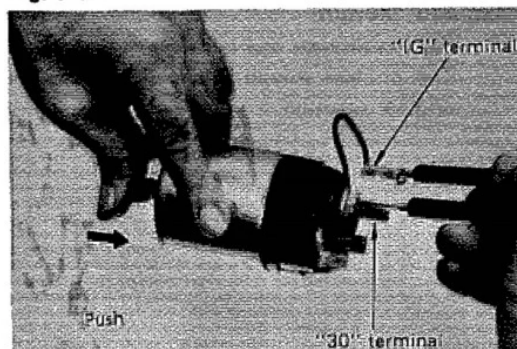

5. I.G. terminal continuity test.
Push in plunger until it stops. Check for continuity between "30" terminal and lead wire.

Perform the switch operation test after assembling it to the motor.

See page 7-17.

ASSEMBLY

Assemble in numerical order.

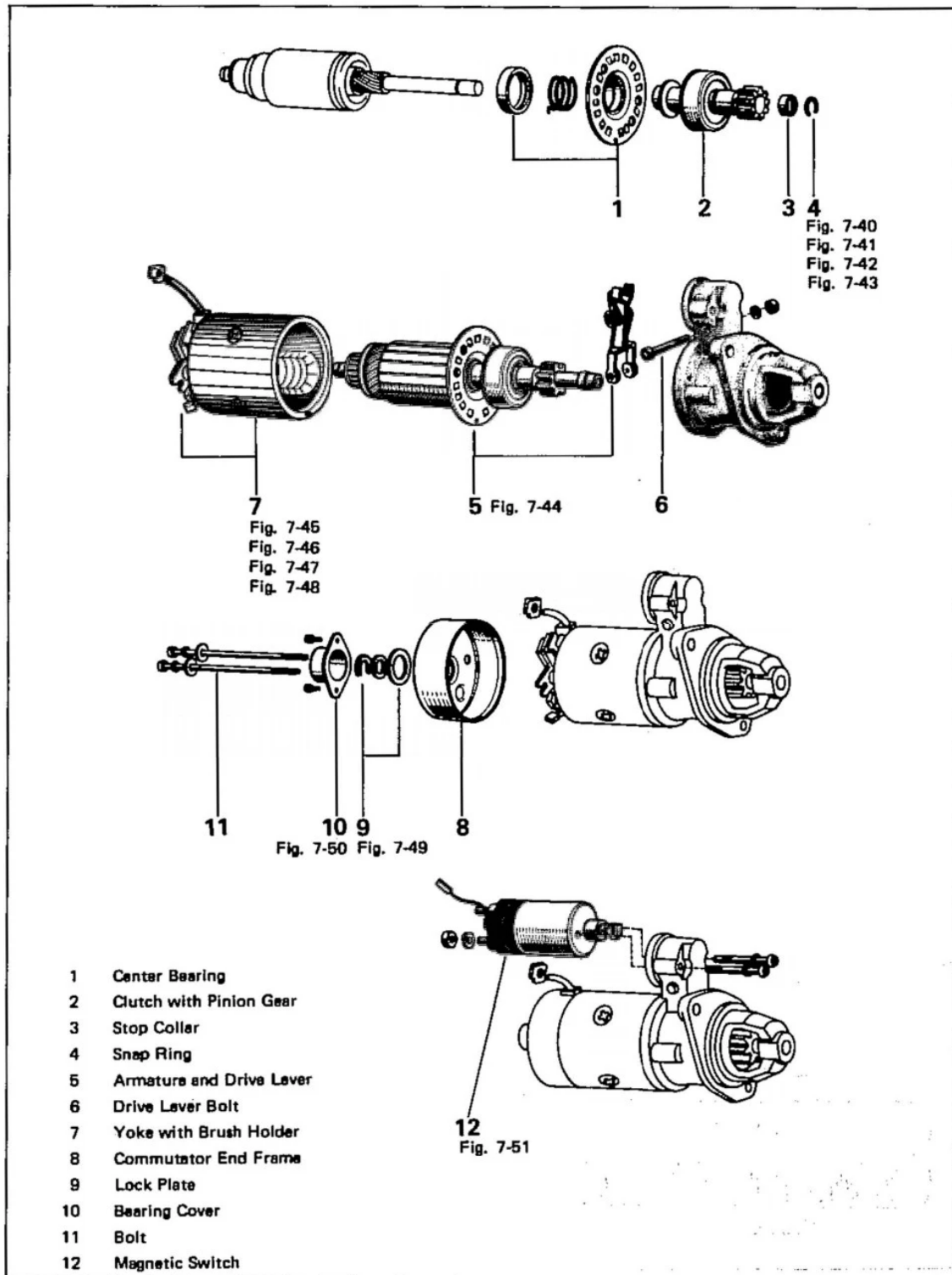
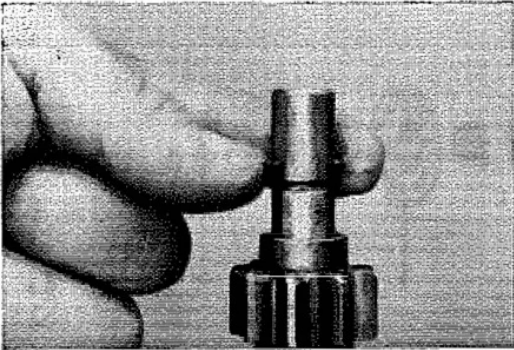

Fig. 7-39

Fig. 7-40



Fit snap ring into shaft groove.

Fig. 7-41

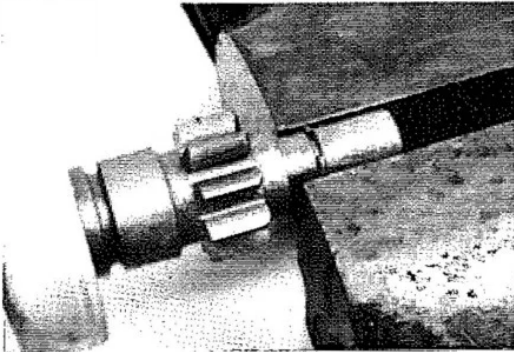

Compress the snap ring with a vise.

Fig. 7-42

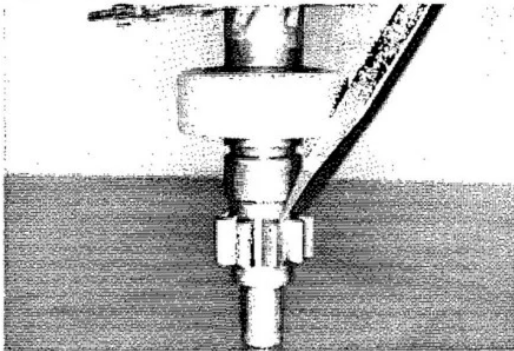

Tap pinion to slide the stop collar onto snap ring.

Fig. 7-43

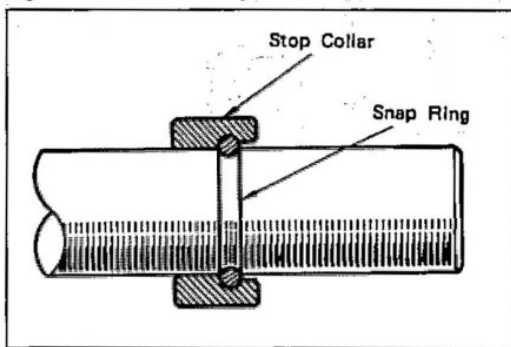

Make sure that the snap ring fits correctly.

Fig. 7-44

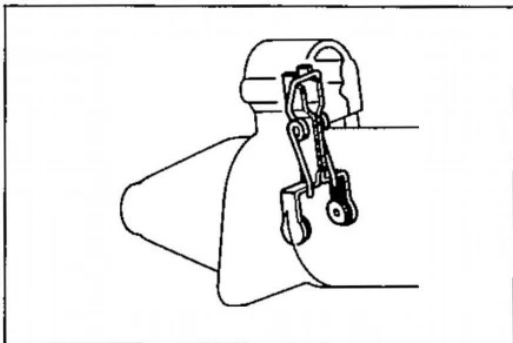

Assemble drive lever in direction as shown.

Fig. 7-45

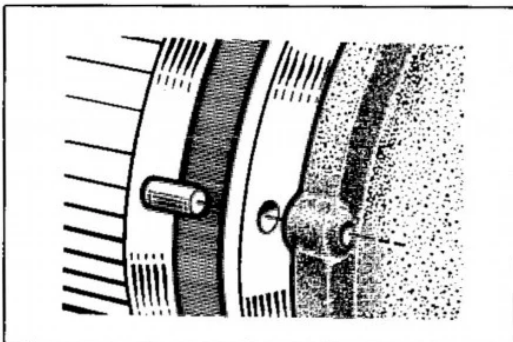

Align the dowel with holes of center bearing support and drive end housing.

Fig. 7-46

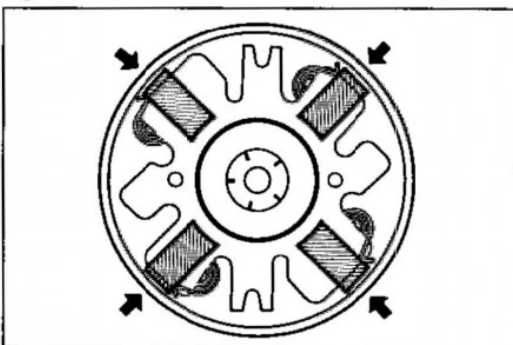

Assemble brushes, being careful not to damage them.

Fig. 7-47

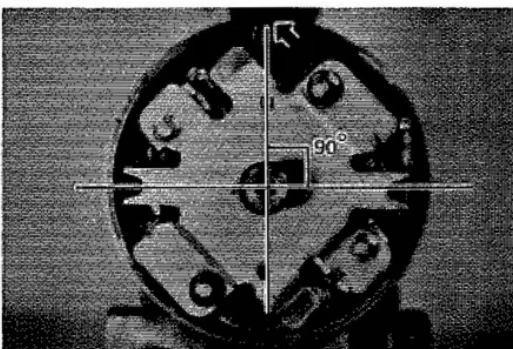

After installation, position the holder as shown.

– Precaution –

These tests must be performed in short time (3-5 seconds) to prevent the coil from burning. Disconnect the field coil lead from "C" terminal.

PERFORMANCE TEST

Check the magnetic switch performance and pinion gap as follows:

Fig. 7-52

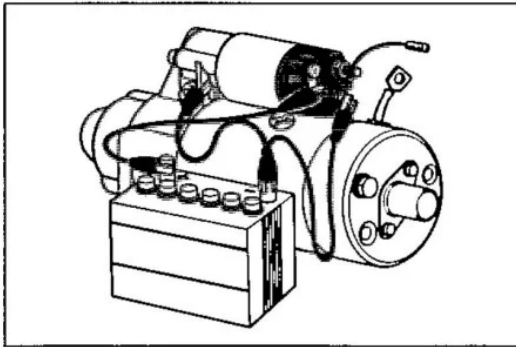

1. Pull-in test
Connect magnetic switch to battery as shown. (negative side to "C" terminal and switch body; positive side to "50" terminal). If the pinion has definitely jumped out, the pull-in coil is satisfactory.

Fig. 7-53

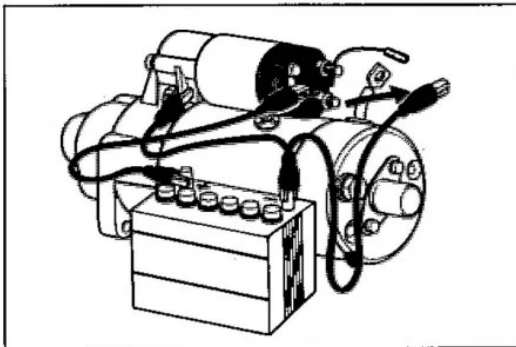

2. Hold-in test
Next disconnect the "C" terminal. The pinion should remain in jumped-out condition.

Fig. 7-54

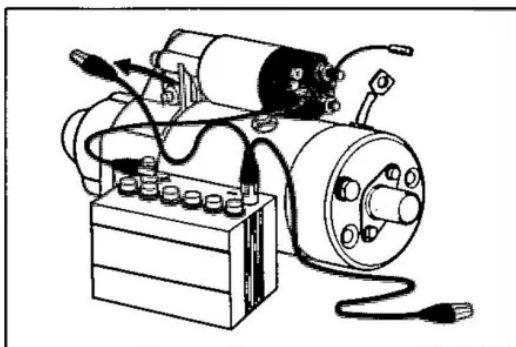

3. Check the plunger return.
When disconnecting the switch body, the pinion should return quickly.

Fig. 7-55

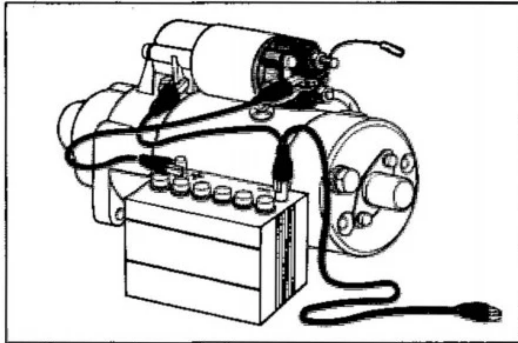

4. Check the pinion clearance.
- (1) Connect the magnetic switch to battery as shown.
Field coil lead to "C" terminal
Battery negative side to body
Battery positive side to 50 terminal

Fig. 7-56

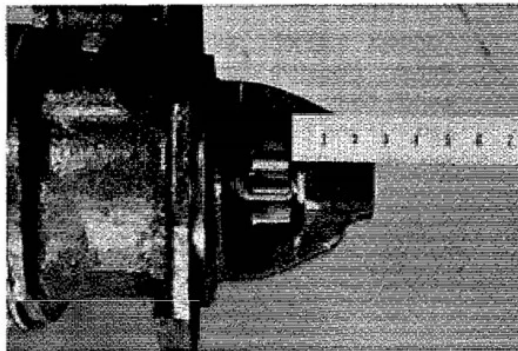

- (2) Move the pinion to armature side to eliminate the slack, and check the clearance between the pinion end and stop collar.

Standard clearance

0.2-4.0 mm
(0.008-0.16 in)

Fig. 7-57

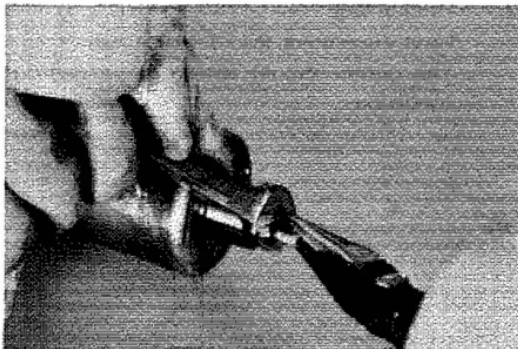

- (3) Adjust if necessary after loosening lock nut.

| <u>Clearance</u> | | <u>Stud</u> |
|------------------|---|-------------|
| Too large | → | Screw in |
| Too small | → | Screw out |

Fig. 7-58

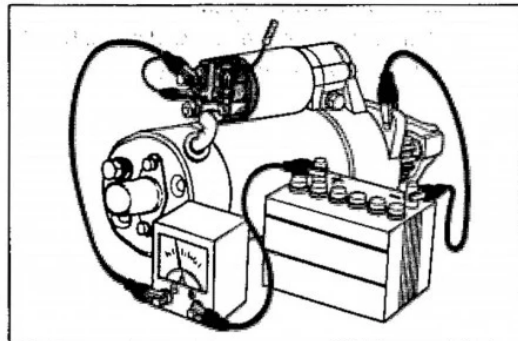

5. No-load performance test
Connect the field coil lead to the "C" terminal, making sure that the lead wire is not grounded.
Connect starter to battery. If the starter shows smooth and steady rotation with the pinion jumping out and draws less than specified current, it is satisfactory.

Specified current

Less than 50 A

IGNITION SYSTEM

| | Page |
|---------------------------------------|-------------|
| IGNITION SYSTEM CIRCUITS | 8- 2 |
| DISTRIBUTOR | 8- 4 |
| DISASSEMBLY | 8- 4 |
| INSPECTION & REPAIR | 8- 6 |
| ASSEMBLY | 8-10 |
| ADJUSTMENT | 8-12 |
| DISTRIBUTOR (W/IGNITER) | 8-13 |
| DISASSEMBLY | 8-13 |
| INSPECTION & REPAIR | 8-15 |
| ASSEMBLY | 8-19 |
| ADJUSTMENT | 8-21 |
| INSTALLATION | 8-23 |
| IGNITION COIL | 8-24 |
| HIGH TENSION CORD | 8-25 |
| SPARK PLUG | 8-26 |
| IGNITER..... | 8-27 |

IGNITION SYSTEM CIRCUITS

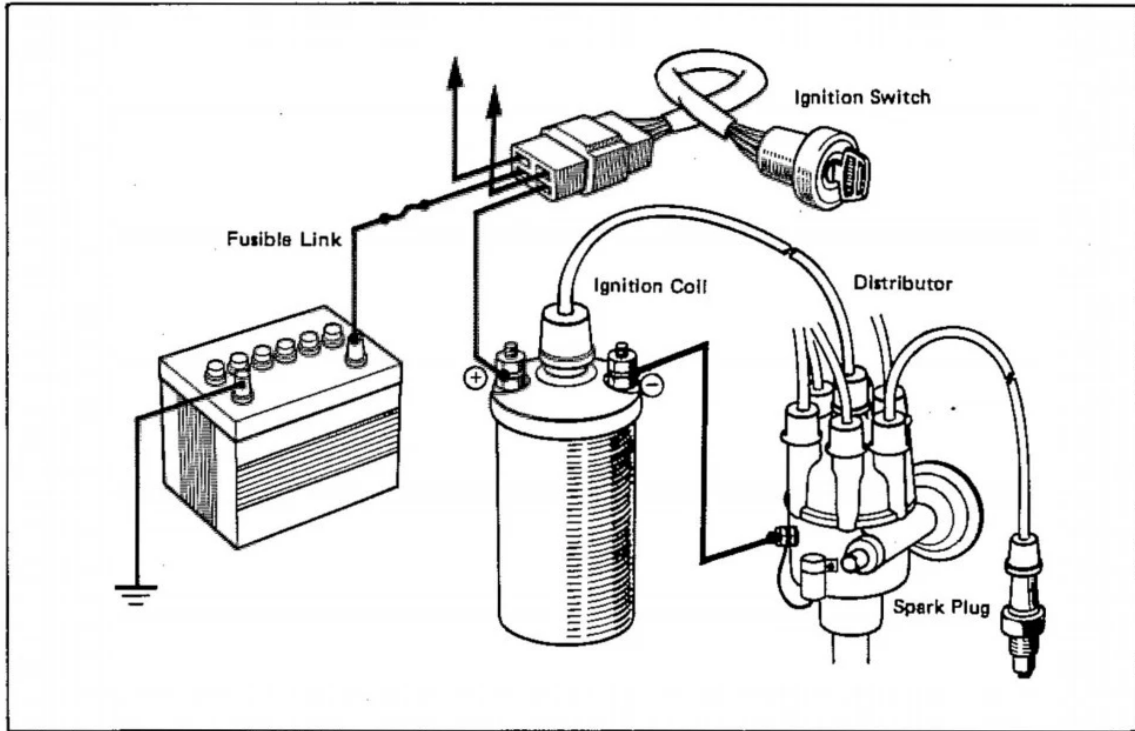

Fig. 8-1

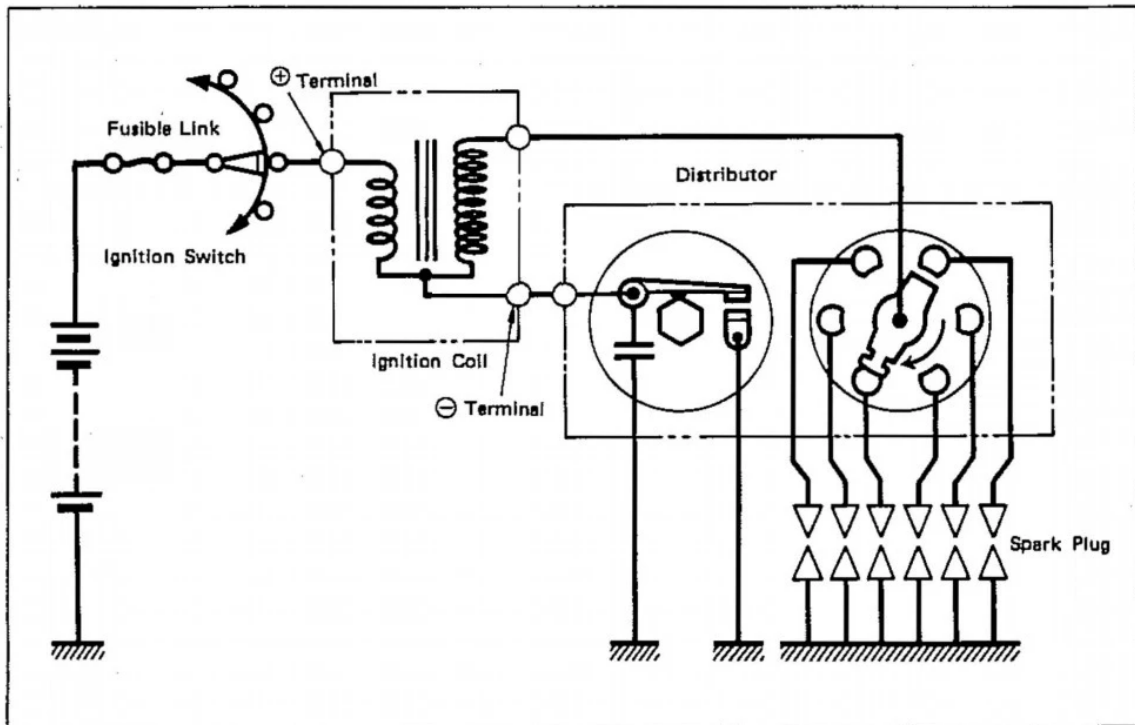

Fig. 8-2

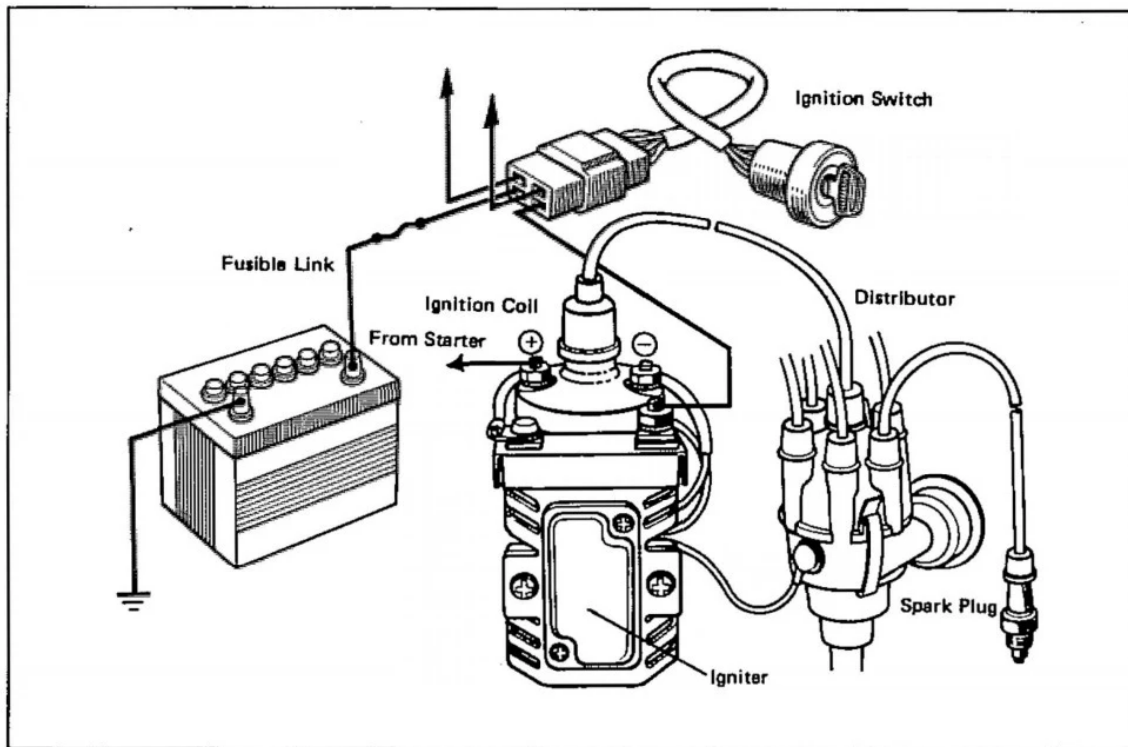

Fig. 8-3

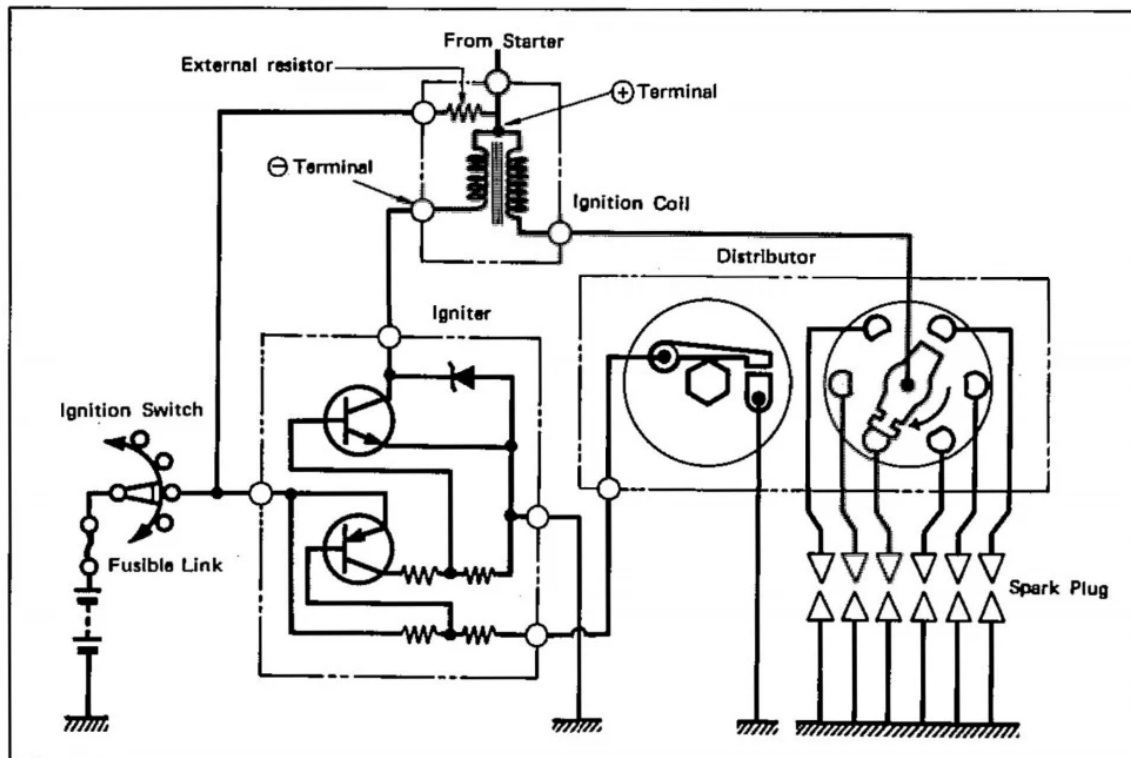

Fig. 8-4

DISTRIBUTOR**DISASSEMBLY**

Disassemble in numerical order.

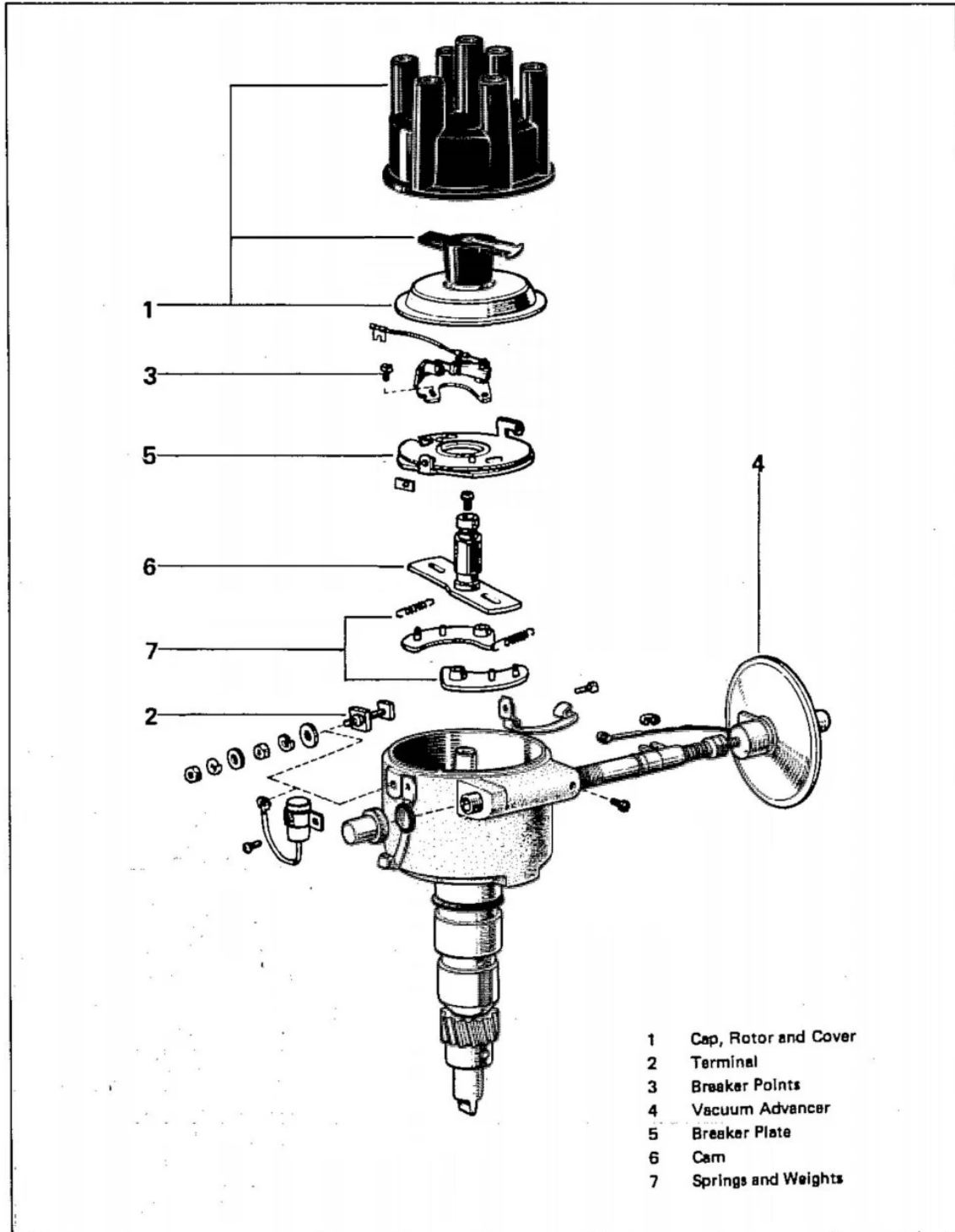

Fig. 8-5

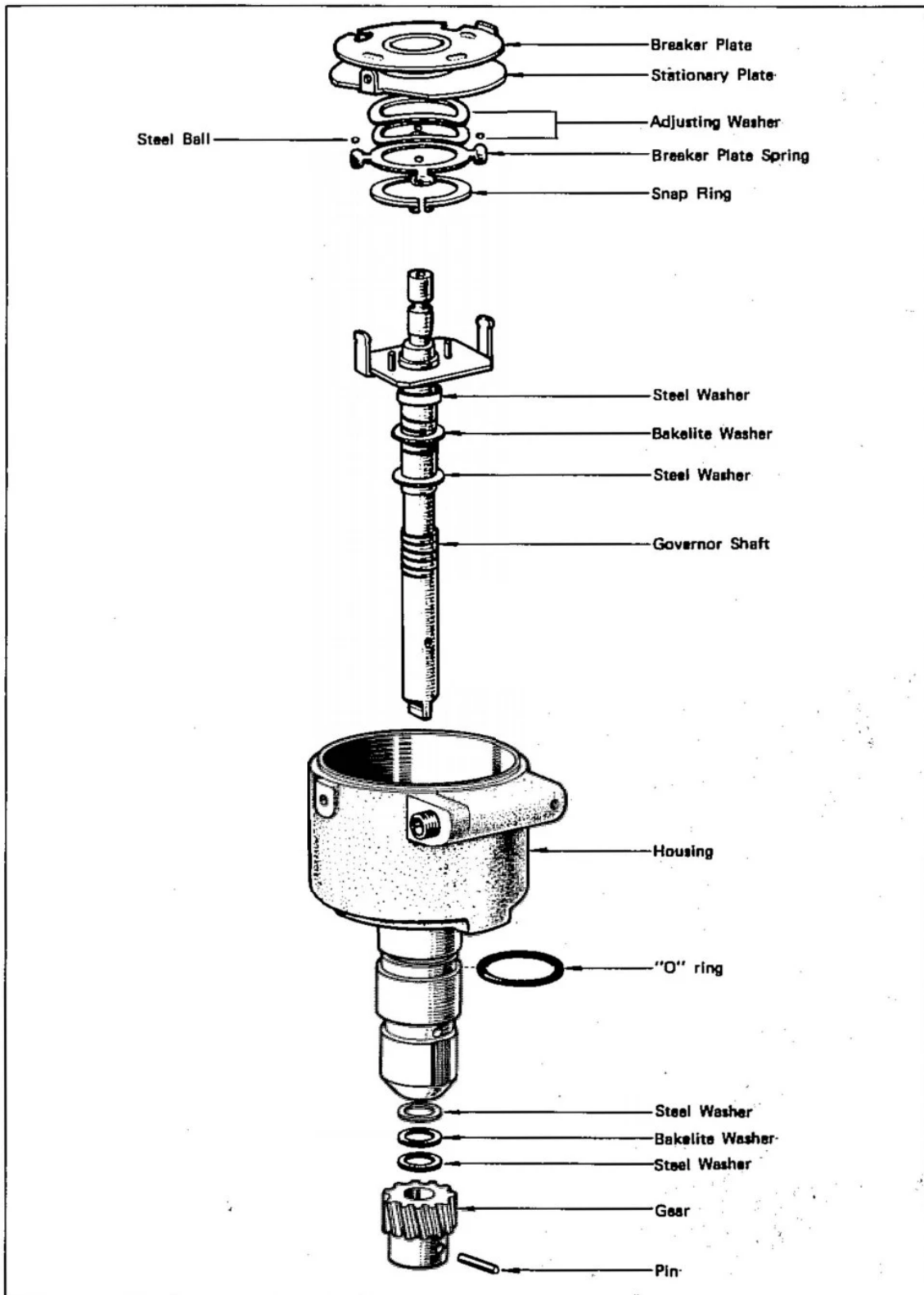

Fig. 8-6

Fig. 8-7

**INSPECTION & REPAIR****Cap**

Inspect for cracks, carbon tracks, burnt or corroded terminals, and check center contact for wear.

Fig. 8-8

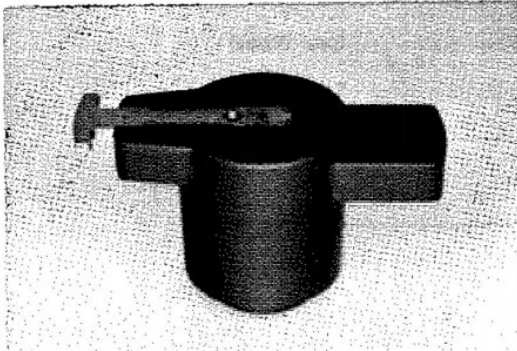
**Rotor**

Inspect for cracks, carbon tracks, burnt or corroded terminals.

Fig. 8-9

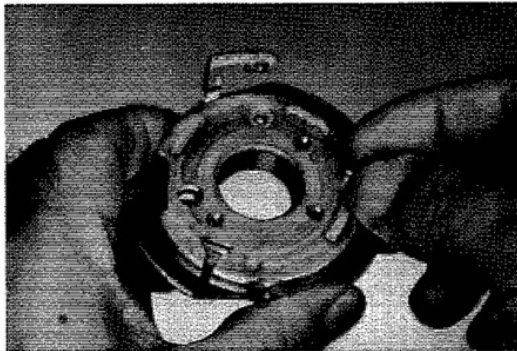
**Breaker Plate**

Check breaker plate for smooth rotation.

Fig. 8-10

**Governor Weights and Pin**

Check the fitting portions of governor weights with support pins for binding.

Fig. 8-15

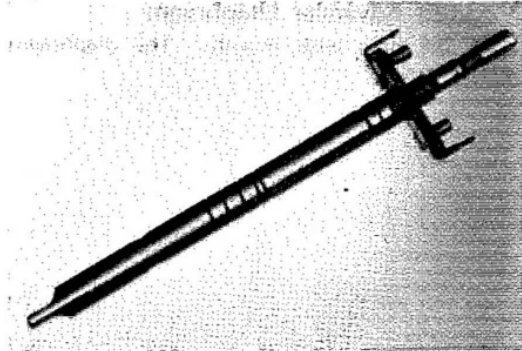

3. Inspect governor shaft for wear and damage.

Fig. 8-16

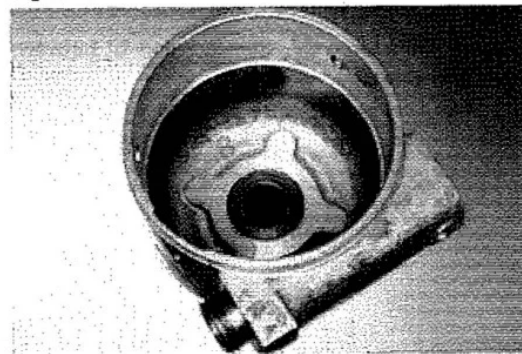

4. Inspect housing bushings, and O ring for wear, deformation, and damage.

Fig. 8-17

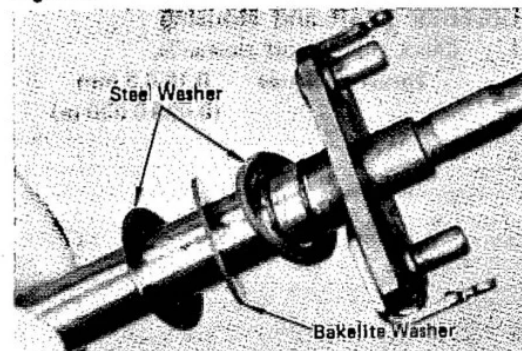

5. Assemble washers in order as shown.

Fig. 8-18

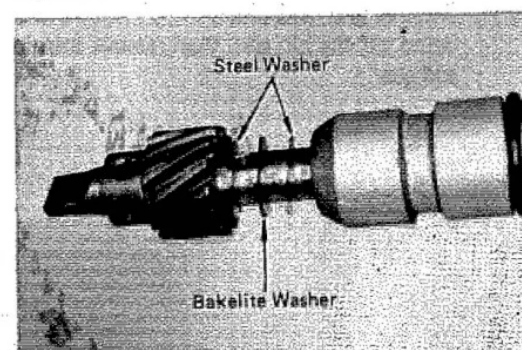

6. Assemble washers and gear in order as shown and check thrust clearance. If it exceeds specified value, adjust the clearance with steel washer.

Fig. 8-19

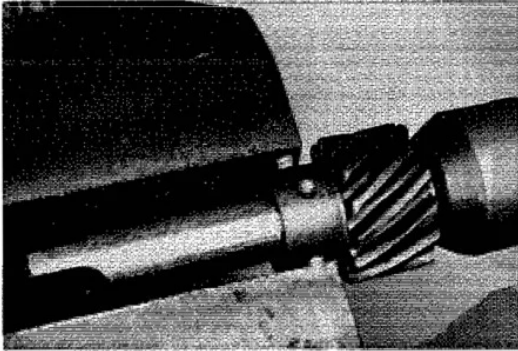

7. Peen both pin ends with a vise.

ASSEMBLY

Assemble in numerical order.

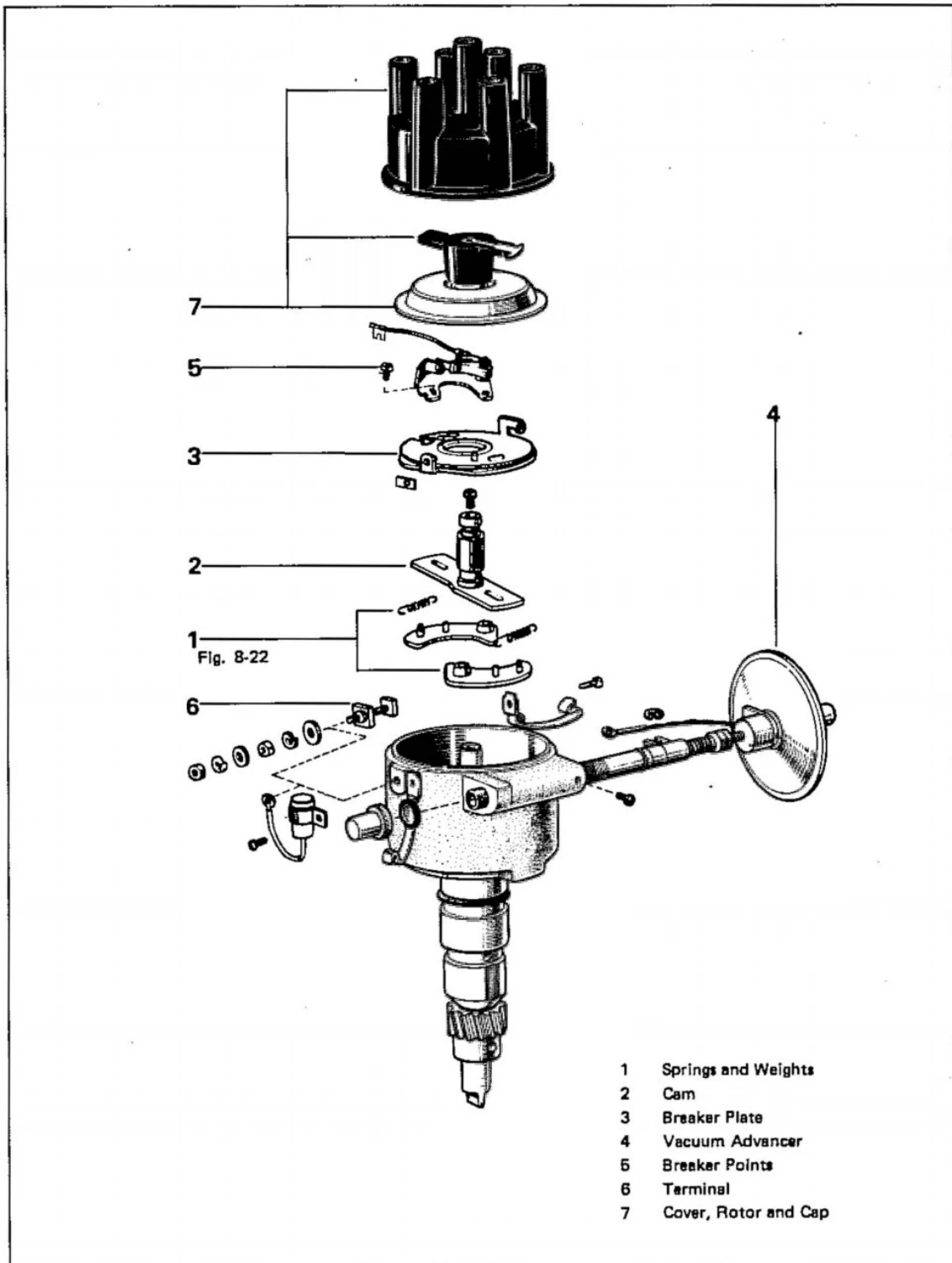

- 1 Springs and Weights
- 2 Cam
- 3 Breaker Plate
- 4 Vacuum Advancer
- 5 Breaker Points
- 6 Terminal
- 7 Cover, Rotor and Cap

Fig. 8-20

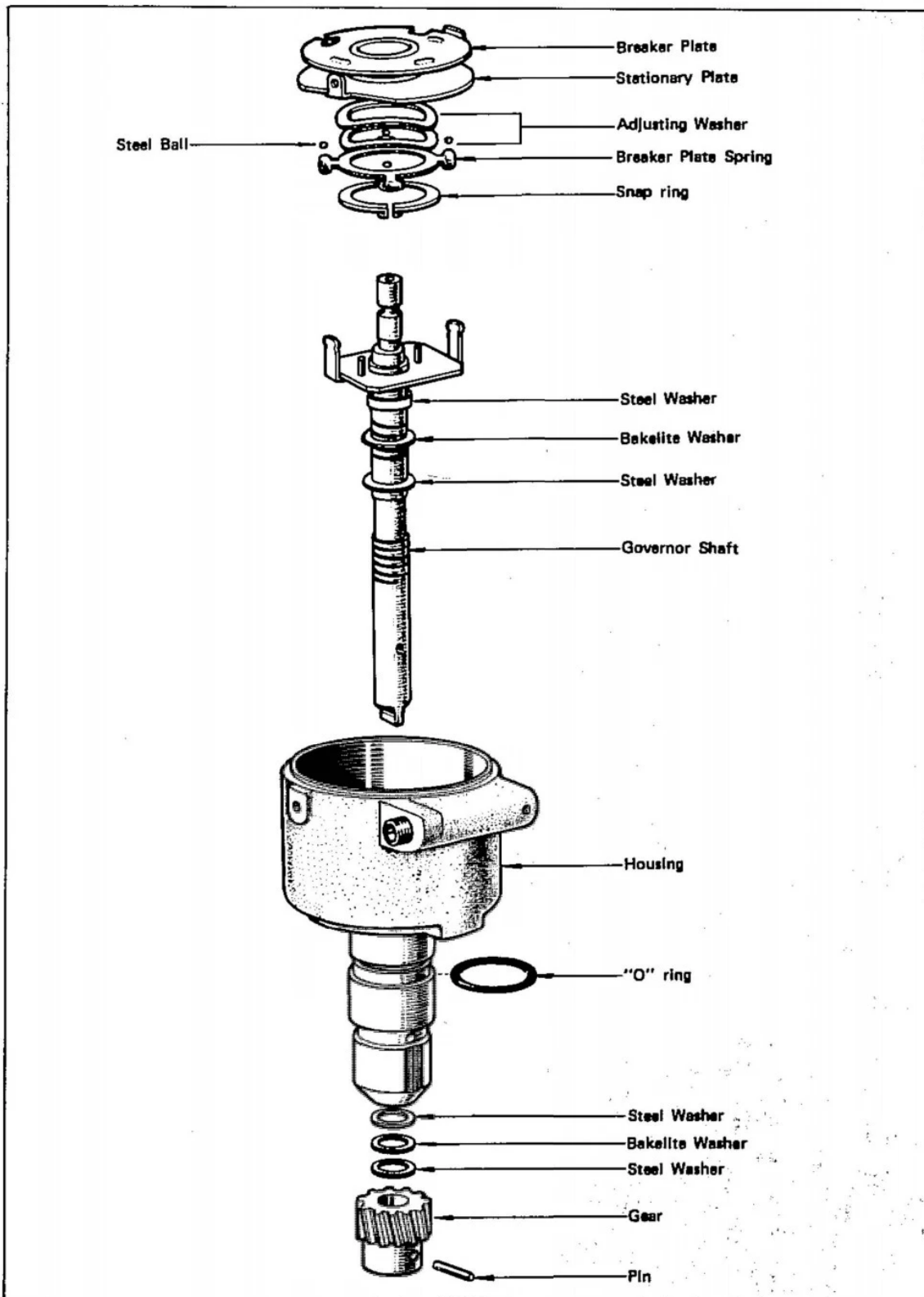
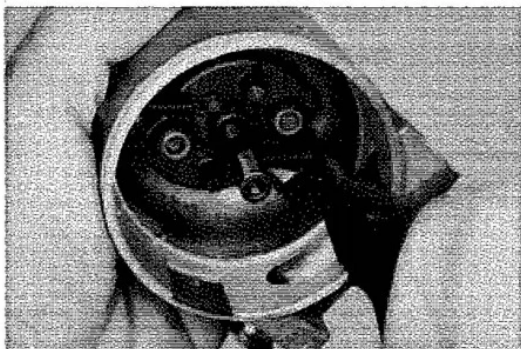

Fig. 8-21

Fig. 8-22



Install governor springs in direction as shown.

Fig. 8-23

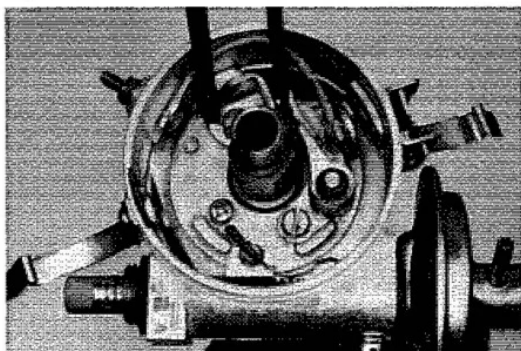
**ADJUSTMENT**

Install breaker points and adjust the gap.

Point gap 0.45 mm (0.018 in)

Fig. 8-24

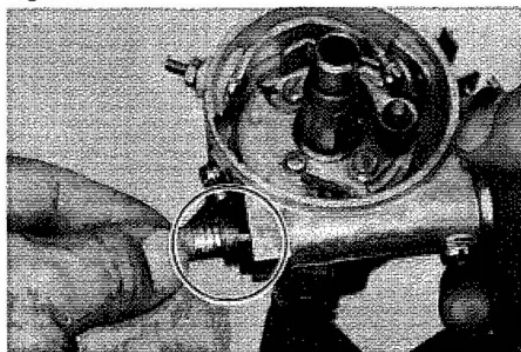

Set the octane selector at standard line.

Fig. 8-25

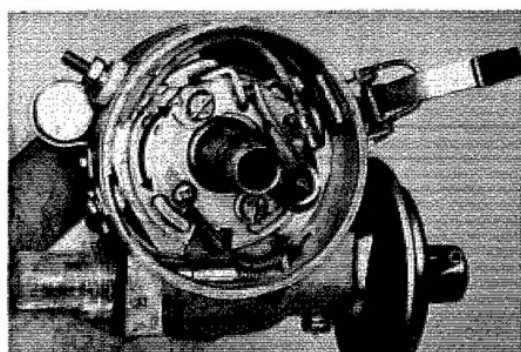

Check breaker plate for smooth rotation.
For installation, refer to page 8-23.

DISTRIBUTOR (W/IGNITER)

DISASSEMBLY

Disassemble in numerical order.

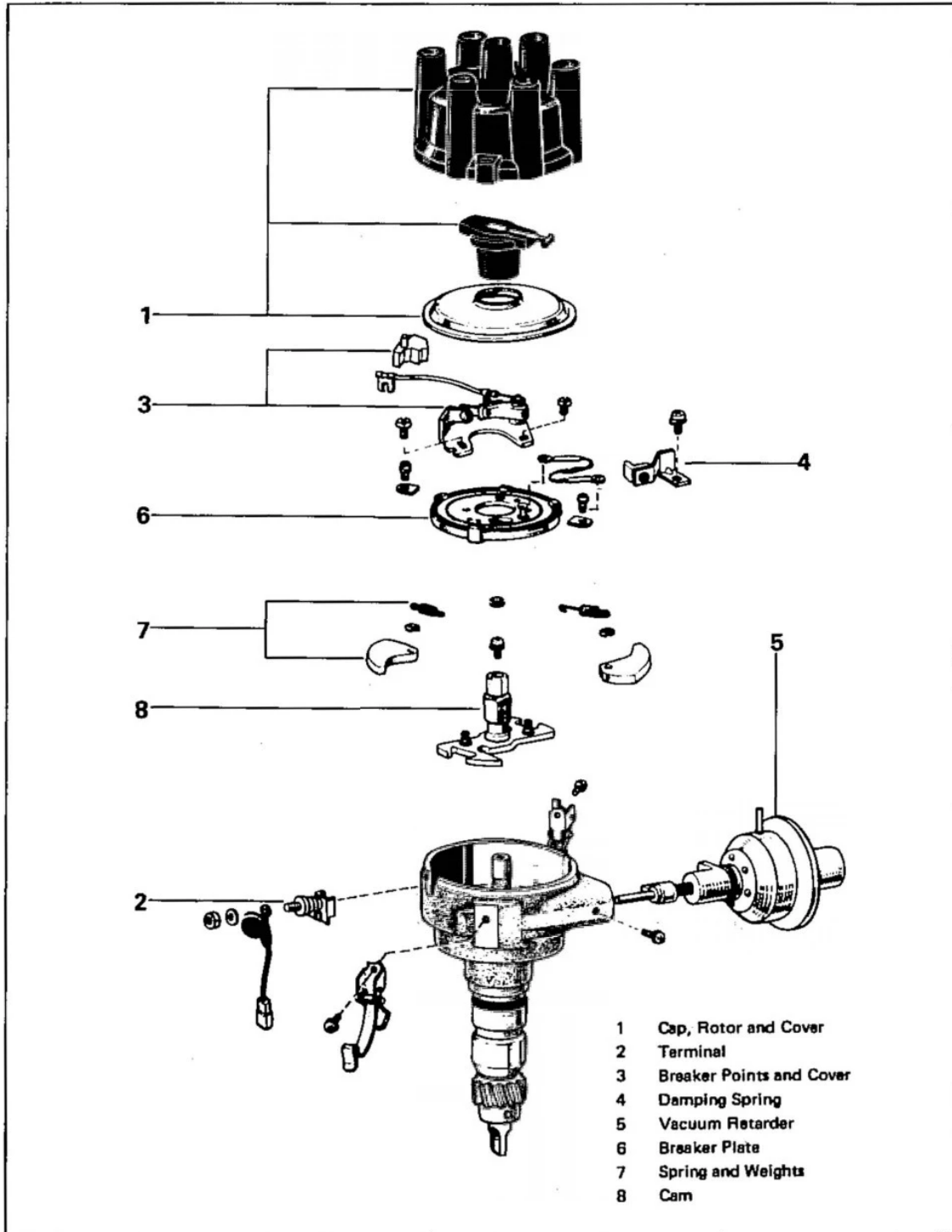

Fig. 8-26

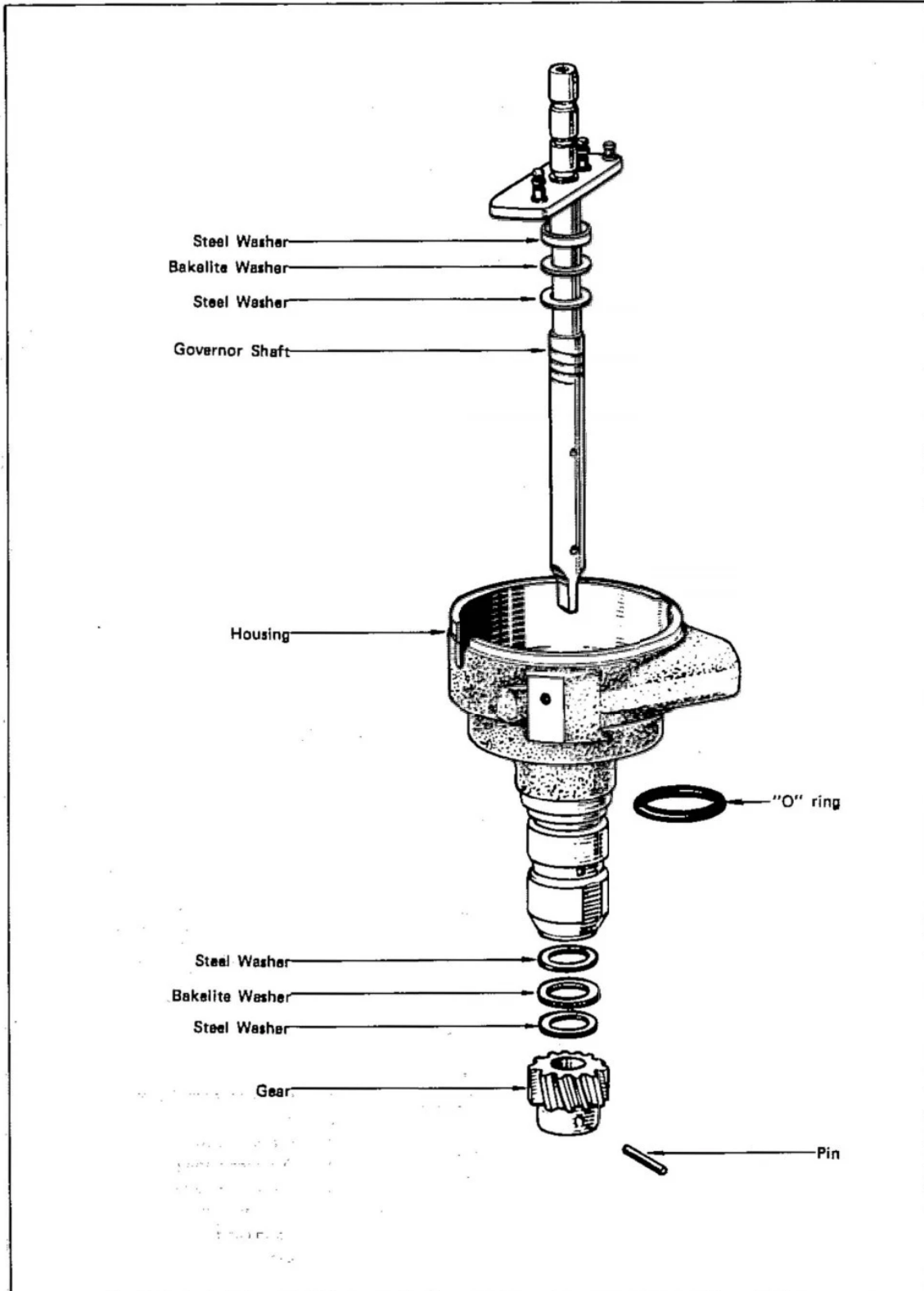
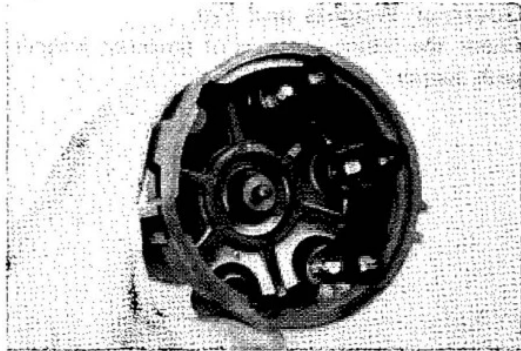

Fig. 8-27

Fig. 8-28



INSPECTION & REPAIR

Cap

Inspect for cracks, carbon tracks, burnt or corroded terminals, and check center contact for wear.

Fig. 8-29

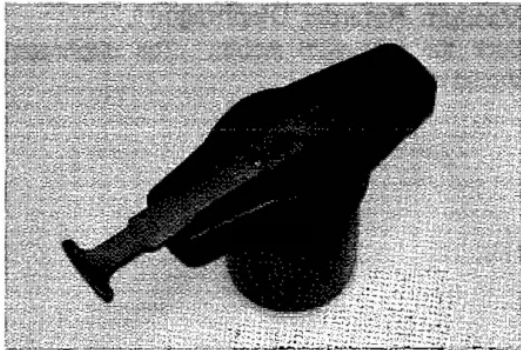

Rotor

Inspect for cracks, carbon tracks, burnt or corroded terminals.

Fig. 8-30

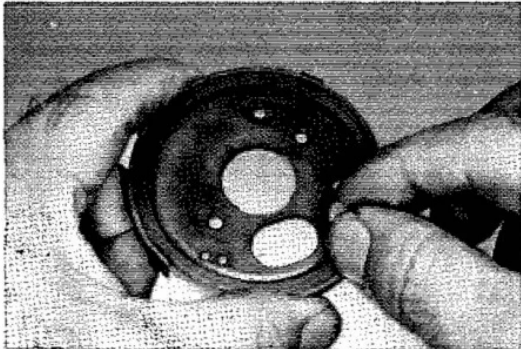

Breaker Plate

Check breaker plate for smooth rotation.

Fig. 8-31

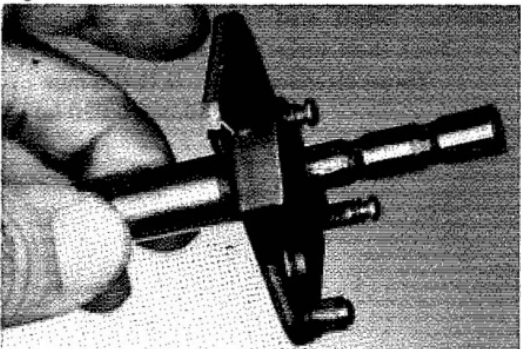

Governor Weights

Inspect governor weights for damage.

Fig. 8-36

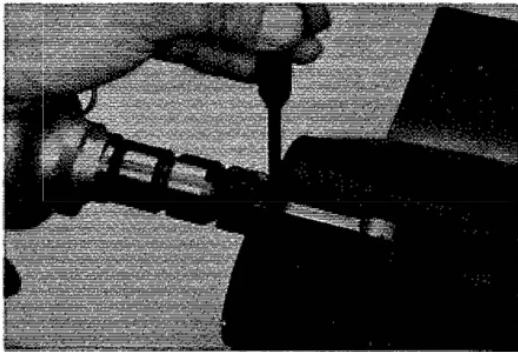

2. Remove gear and pin
Grind off the pin end, then remove the pin and gear.

Fig. 8-37

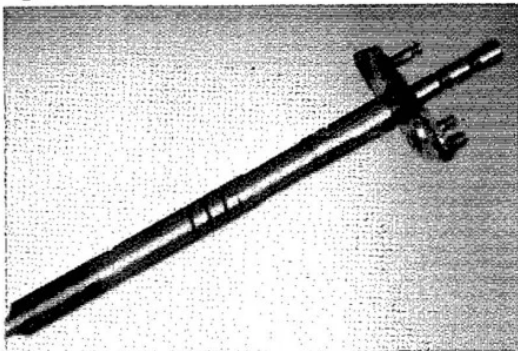

3. Inspect governor shaft for wear and damage.

Fig. 8-38

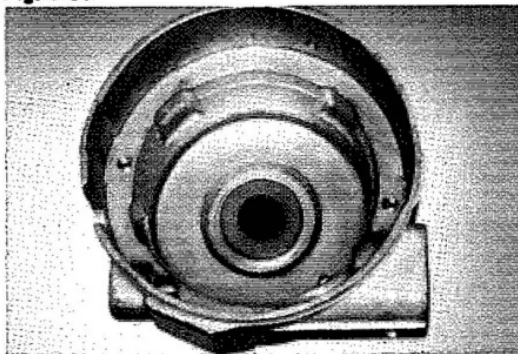

4. Inspect housing bushings, and O ring for wear, deformation, and damage.

Fig. 8-39

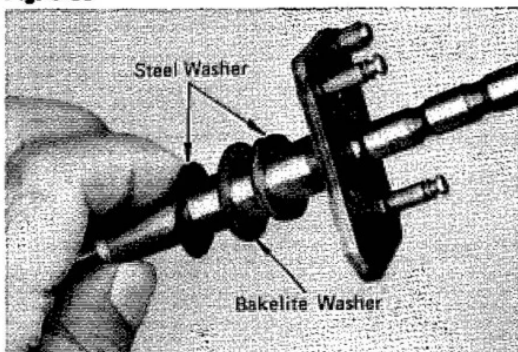

5. Assemble washers in order as shown.

Fig. 8-40

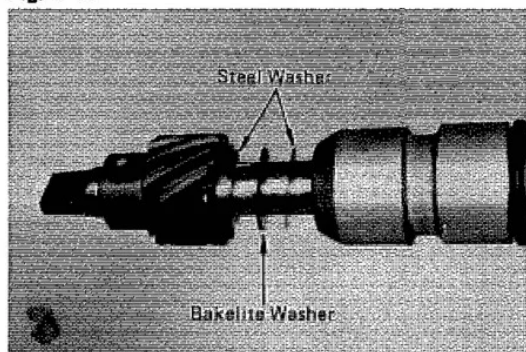

6. Assemble washers and gear in order as shown and check thrust clearance. If it exceeds specified value, adjust the clearance with steel washer.

Fig. 8-41

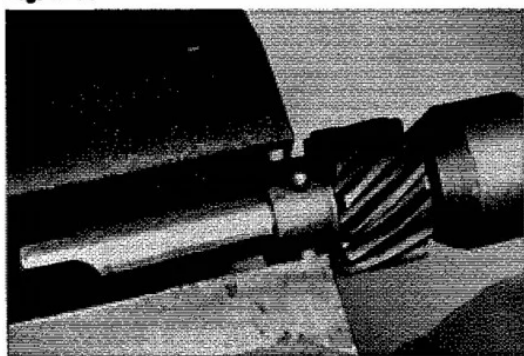

7. Peen both pin ends with a vise.

ASSEMBLY

Assemble in numerical order.

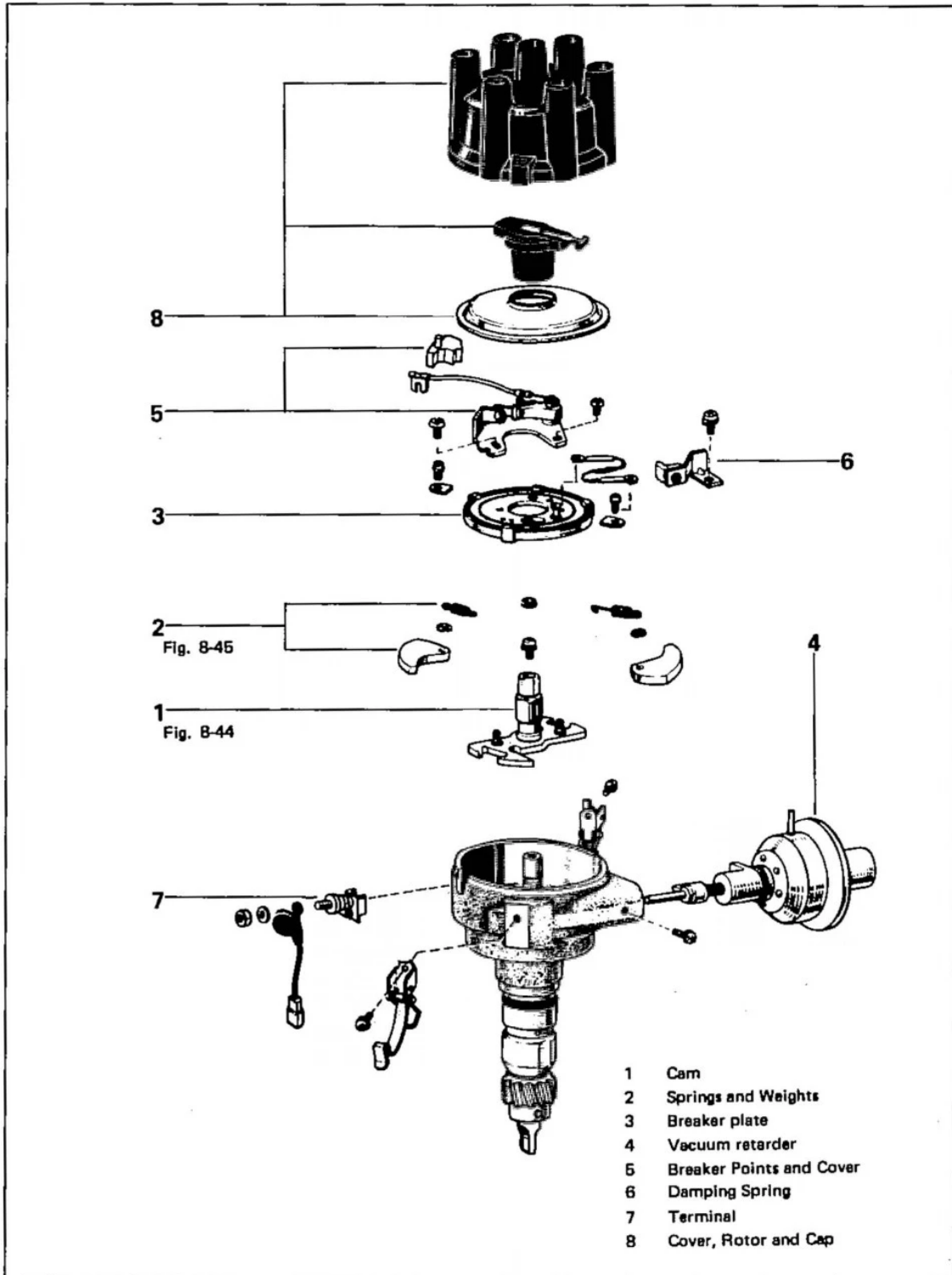

Fig. 8-42

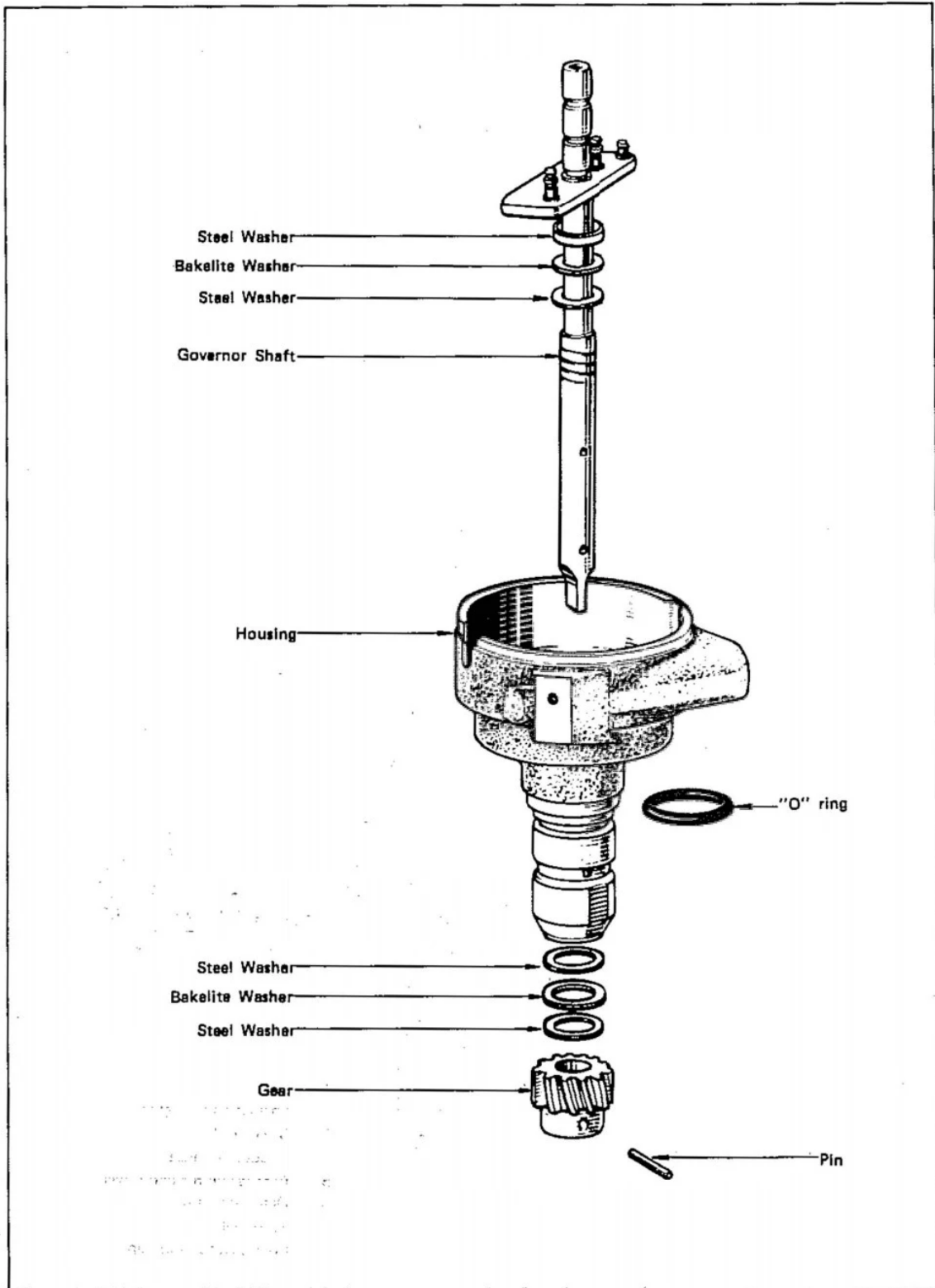
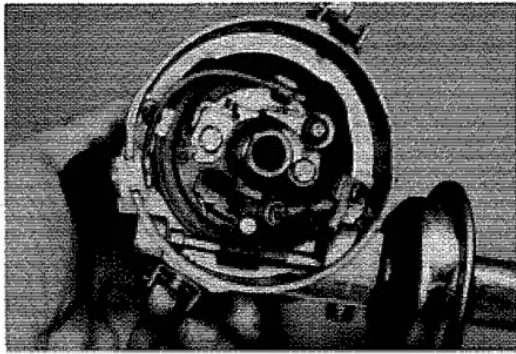

Fig. 8-43

Fig. 8-48



Check breaker plate for smooth rotation.

Fig. 8-49

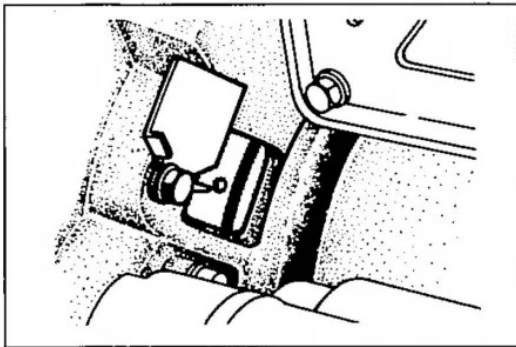

Fig. 8-50

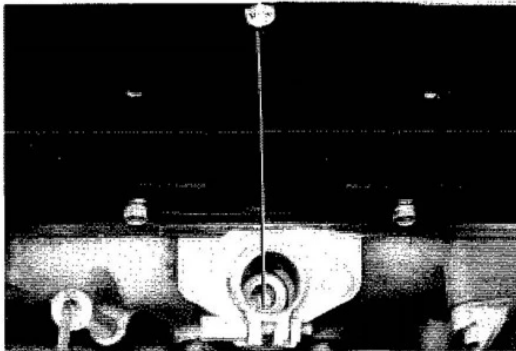

Fig. 8-51

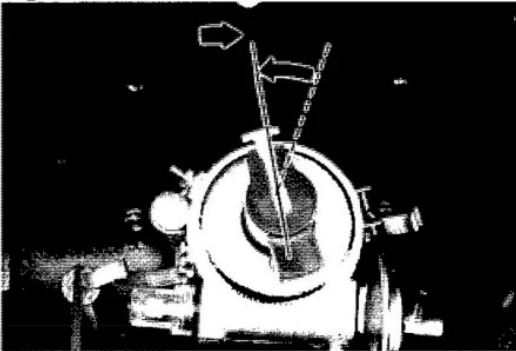
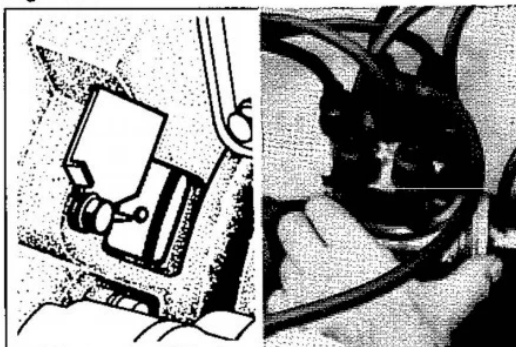

Fig. 8-52

**INSTALLATION**

1. Set No. 1 cylinder to 7° BTDC/compression. Align the timing ball with pointer. At this time, rocker arms on No. 1 cylinder should be loose and rockers on No. 6 should be tight.

2. Set the oil pump shaft slot in direction as shown.

3. Begin insertion of distributor with diaphragm and rotor pointing the position as shown. When fully installed, rotor should point toward the bolt (arrow). Rotate distributor body to the position where the points are just opening.

4. Check ignition timing in idling condition. For adjustment, turn distributor body and align timing ball with pointer. Make sure that there is oil pressure at engine running.

Fig. 8-53

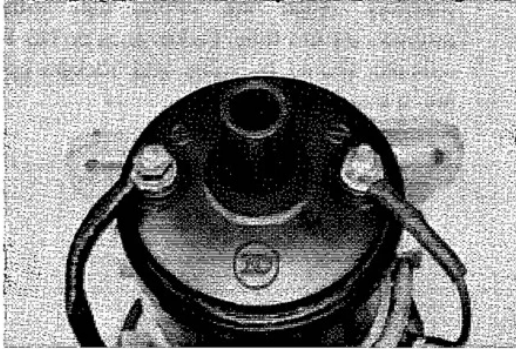

Fig. 8-54

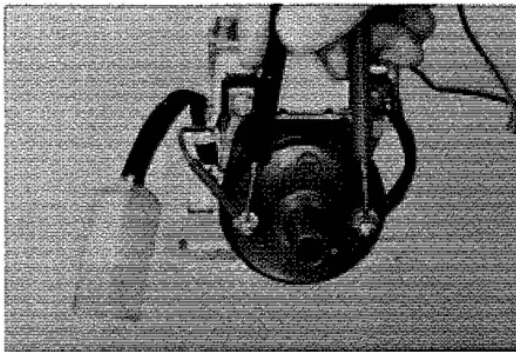

Fig. 8-55

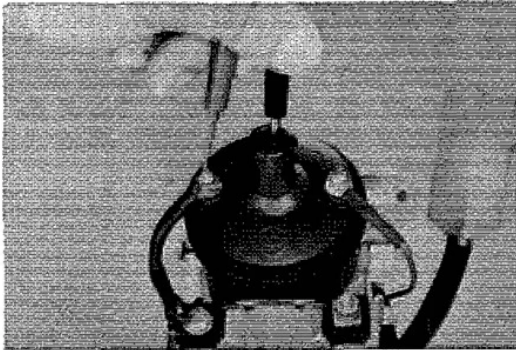
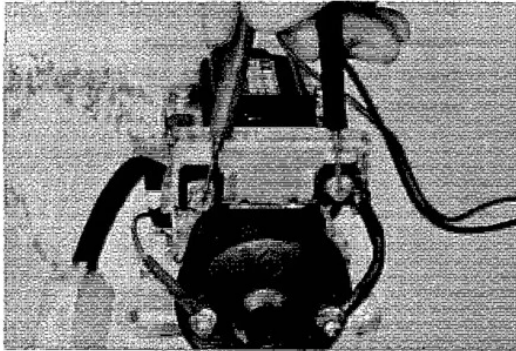

Fig. 8-56



IGNITION COIL INSPECTION



1. Clean the coil and inspect it for carbon paths around the terminals, and check the outside body for cracks.
2. Inspect the high tension cord insertion hole for carbon deposit or corrosion.



3. Measure the following resistances. If the reading is not within the specified resistance, replace coil.

Primary coil resistance (Reference only)

W/O resistor type 2.6-4.0Ω

W/ resistor type 1.3-1.6Ω



Secondary coil resistance

(Reference only)

W/O resistor type 6.0-9.0kΩ

W/ resistor type 9.5-14.5kΩ



External resistor resistance

(Reference only)

1.3-1.7Ω

Fig. 8-57

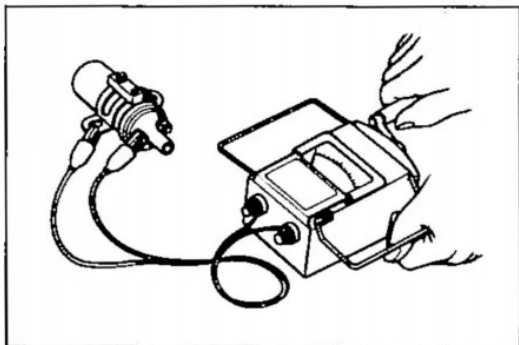

Insulation resistance Over 10MΩ at 500V

Fig. 8-58



HIGH TENSION CORD

— Caution —

1. Remove carefully high tension cords by pulling the rubber boot.

Fig. 8-59

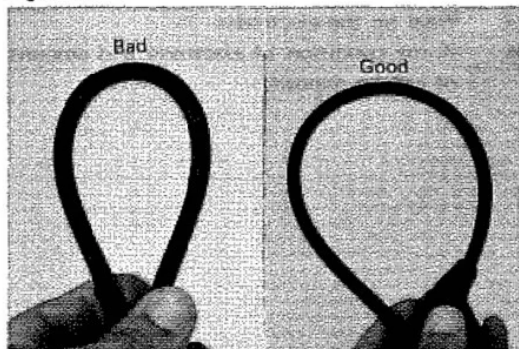

2. Do not bend cords so as to conductor from broken.

Fig. 8-60

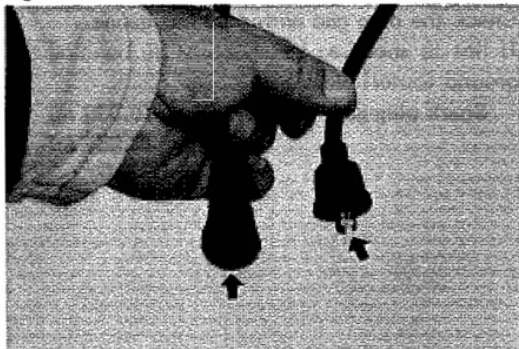

INSPECTION

1. Check the condition of the cord terminal. If any terminal is corroded, clean it, and if it is broken or distorted, replace the cord.

Fig. 8-61

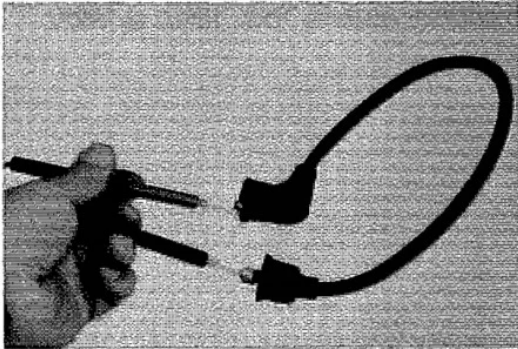

2. Check the resistance of each cord between both ends. If the reading exceeds the limit, replace the cord.

Resistance **Less than 25 k Ω**

Fig. 8-62

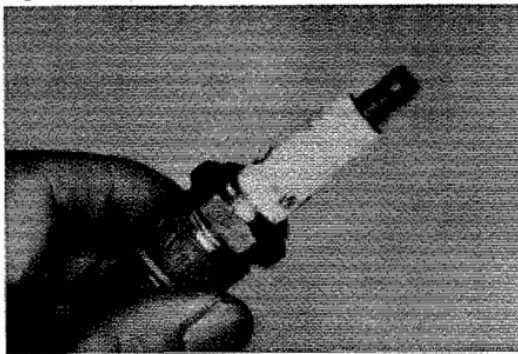

SPARK PLUG INSPECTION

Inspect for the following items. Clean or replace plugs if necessary.

1. Cracks or damages in the threads or insulator.
2. Damaged or deteriorated gaskets.

Fig. 8-63

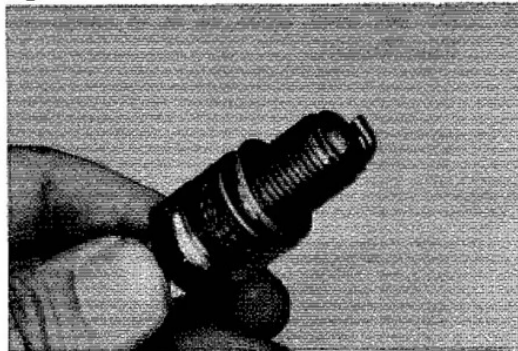

3. Wear on the electrodes.
4. Burnt condition of electrode and amount of carbon deposit.

Fig. 8-64

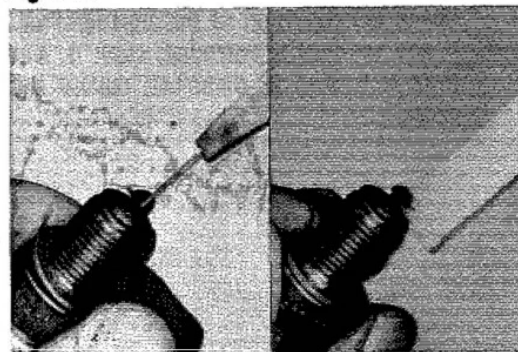

GAP ADJUSTMENT

Check the plug gap with plug gap gauge.

If not to specified value, adjust by bending the ground (outer) electrode.

| | |
|-----------------------|--------------------------|
| Spark plug gap | 0.8 mm (0.031 in) |
| | 1.0 mm (0.039 in) |
| | for USA |

IGNITER INSPECTION

Fig. 8-65

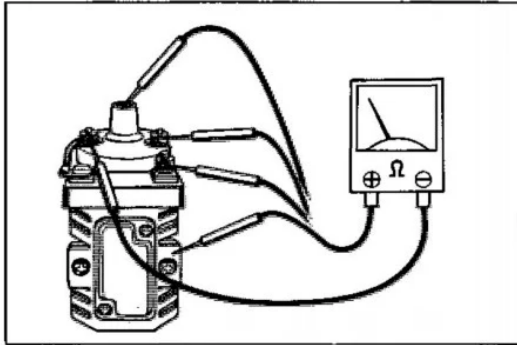

1. Inspect ignition coil resistance beforehand. Refer to Ignition Coil section.

Fig. 8-66

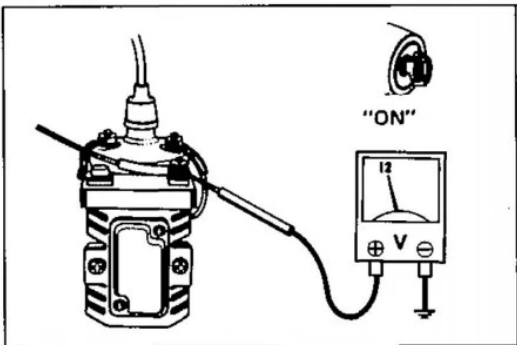

2. Turn the ignition key to ON position.
3. Check if there is battery voltage at resistor terminal as shown.
12V — GOOD
If not — Check ignition switch or wiring harness.

Fig. 8-67

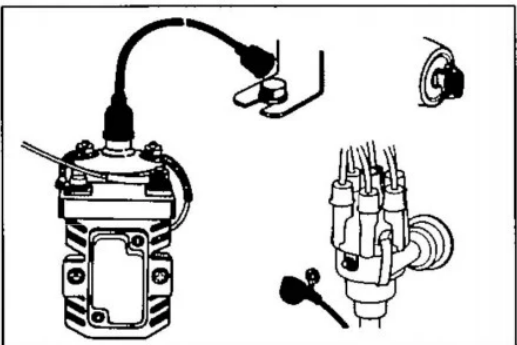

4. Disconnect primary ignition wire and high tension cord from distributor.
5. Keep the cord end to ground distance about 5 mm (0.2 in).

Fig. 8-68

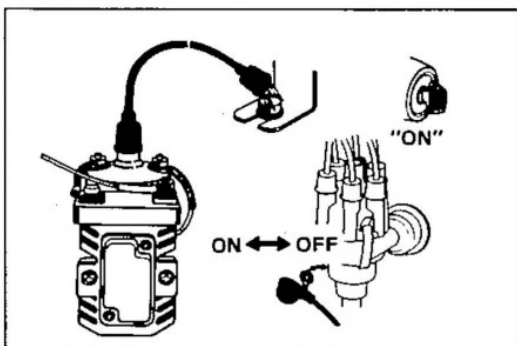

6. Make primary ignition wire ON-OFF contacts with ground.
7. Check if spark is produced at this time.
Spark is produced — Igniter is satisfactory.
Spark is not produced — Igniter is unsatisfactory.

MEMO

[Faint, illegible text, likely bleed-through from the reverse side of the page]

CHARGING SYSTEM

| | Page |
|---|------|
| CHARGING SYSTEM CIRCUITS | 9- 2 |
| ON-VEHICLE INSPECTION | 9- 4 |
| ALTERNATOR (Conventional Type)..... | 9- 9 |
| DISASSEMBLY | 9- 9 |
| INSPECTION AND REPAIR..... | 9-12 |
| ASSEMBLY | 9-15 |
| ALTERNATOR (Heavy Duty Type)..... | 9-21 |
| ALTERNATOR (With Vacuum Pump Type)..... | 9-29 |
| ALTERNATOR REGULATOR | 9-37 |
| INSPECTION AND ADJUSTMENT | 9-37 |

CHARGING SYSTEM CIRCUITS

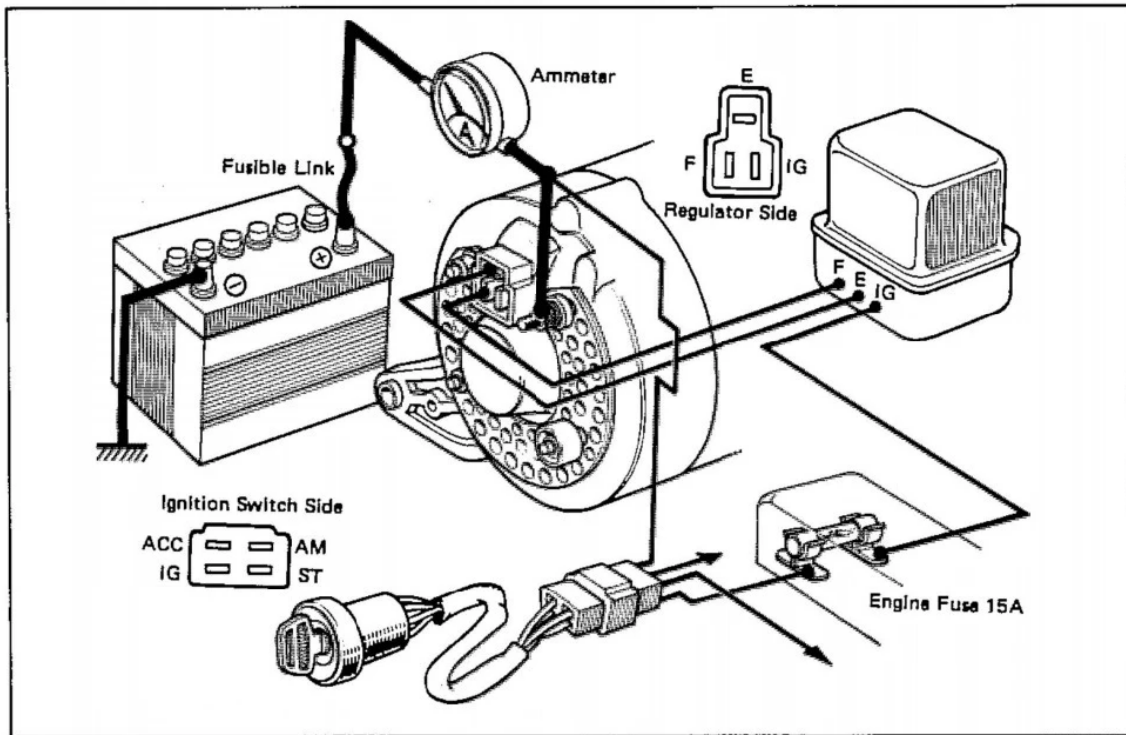

Fig. 9-1

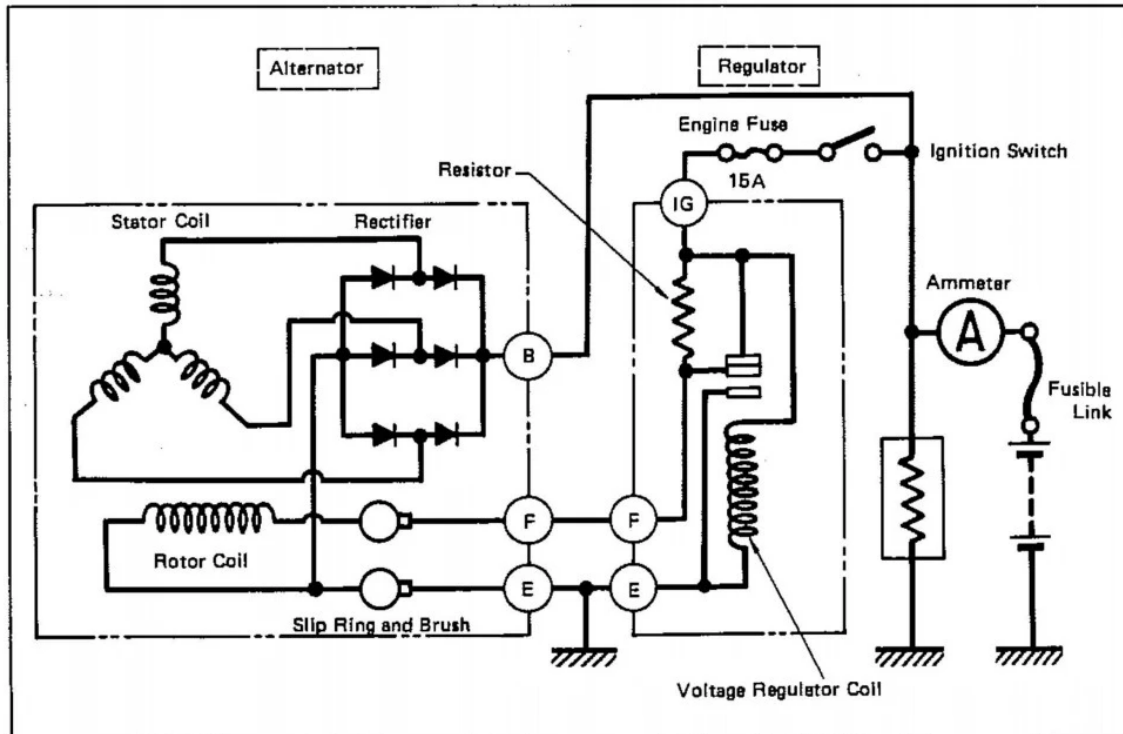

Fig. 9-2

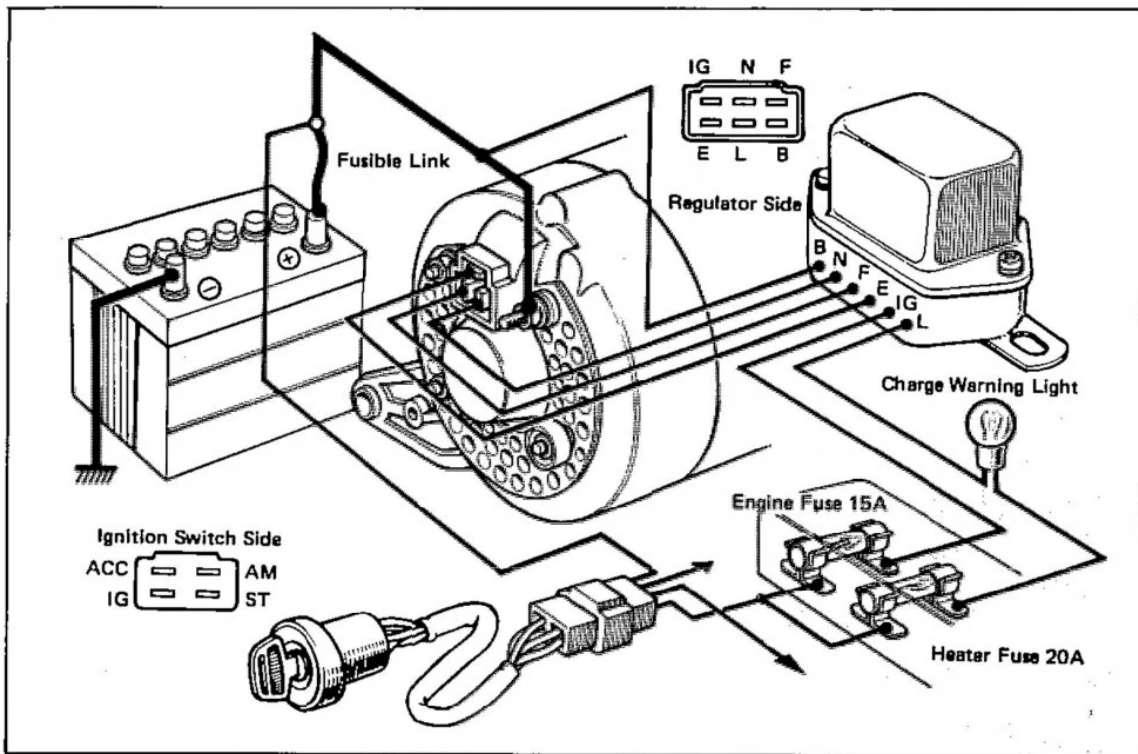

Fig. 9-3

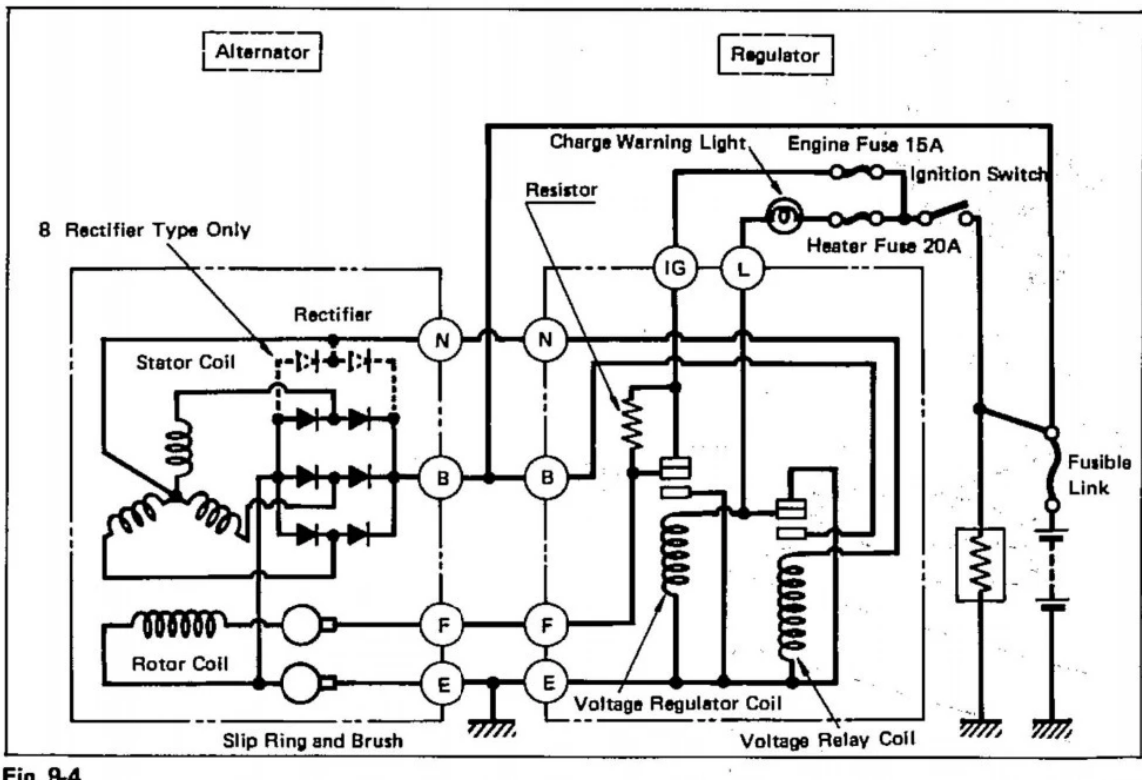
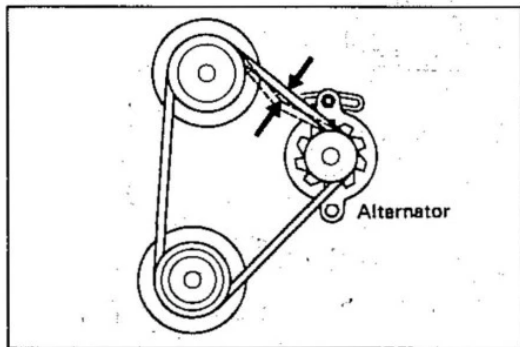

Fig. 9-4

Fig. 9-5



ON-VEHICLE INSPECTION



Inspect system components as follows.

1. Drive belt tension

Fig. 9-6

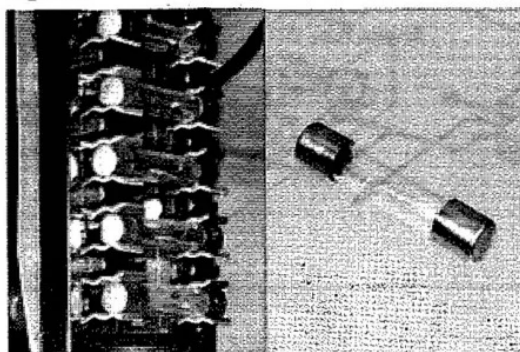

2. Fuses

| | |
|-------------|-----|
| Engine fuse | 15A |
| Heater fuse | 20A |

Fig. 9-7



3. Installed condition of wiring for alternator and regulator.

Fig. 9-8

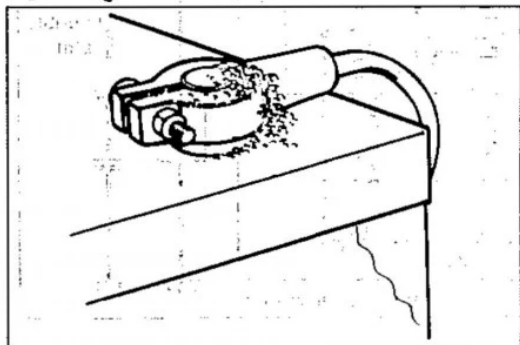

4. Battery terminal and fusible link.
 - Loose
 - Corroded
 - Burnt

Fig. 9-9

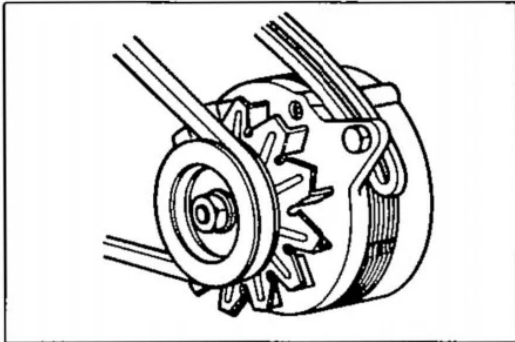

5. Alternator on-vehicle condition
Abnormal noise from alternator when engine is running.

Fig. 9-10

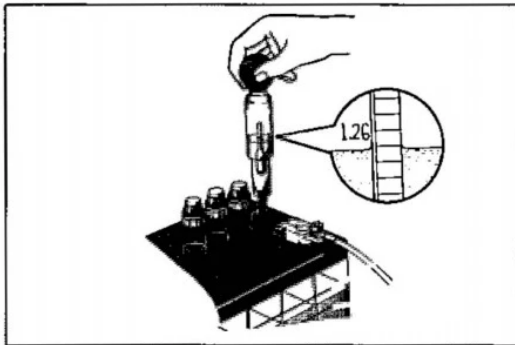

6. Specific gravity 1.25-1.27

Fig. 9-11

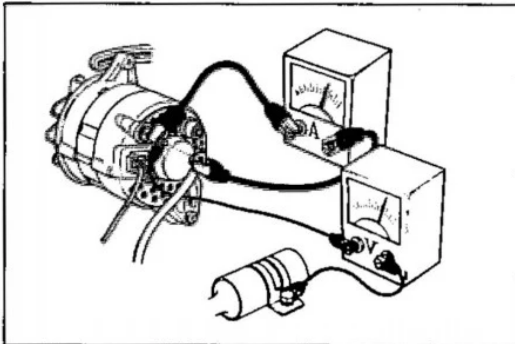

PERFORMANCE TEST USING VOLT-METER AND AMMETER

Connect voltmeter and ammeter as illustrated, and switch off all accessory parts.

Fig. 9-12

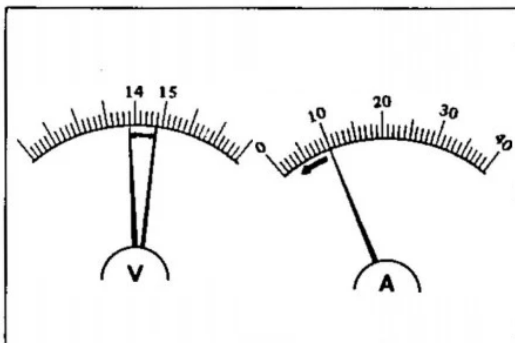

No-load Performance test

- | | |
|-------------------|---------------------|
| Regulated voltage | 13.8 ~ 14.8 V |
| Current | Less than 10 A |
| Engine speed | Idling to 2000 rpm. |

Fig. 9-13

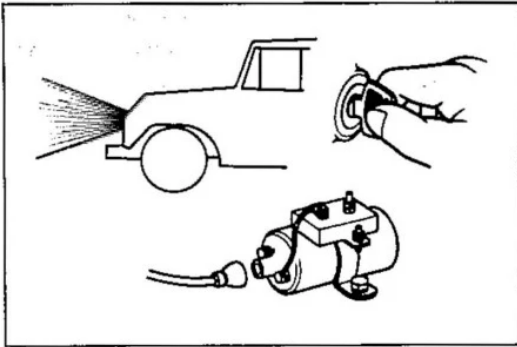

Load Performance test

1. Crank the engine with ignition coil high tension cord disconnected for about 5 to 10 seconds.
2. Turn on headlights and accessories.

Fig. 9-14

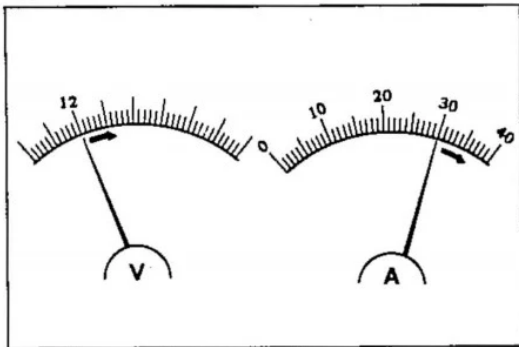

3. Start engine, and run it at approximately 2000 rpm.

| | |
|--------------------------|-----------------------|
| Regulated voltage | 12 V |
| Current | More than 30 A |

Fig. 9-15

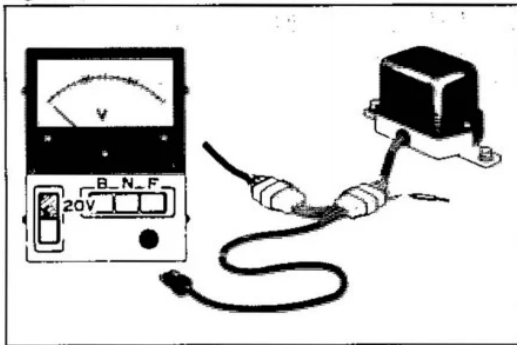

PERFORMANCE TEST BY ALTERNATOR CHECKER

1. Unplug the alternator regulator connector and plug in the checker connector.
Push "20V" switch.

Fig. 9-16

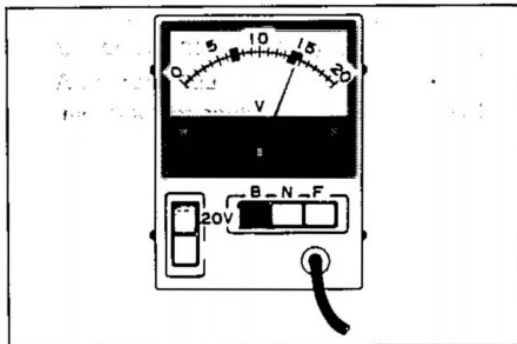

2. Check "B" terminal voltage.
Push "B" switch.
Raise engine speed from idling to 2000 rpm.
Standard voltage 13.8 to 14.8 V

Fig. 9-17

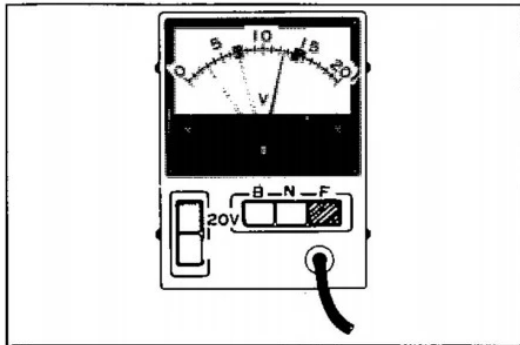

3. Check "F" terminal voltage.
Push "F" switch.
Gradually raise engine speed. The checker reading should gradually decrease from 12 volt to 3 volt.

Fig. 9-18

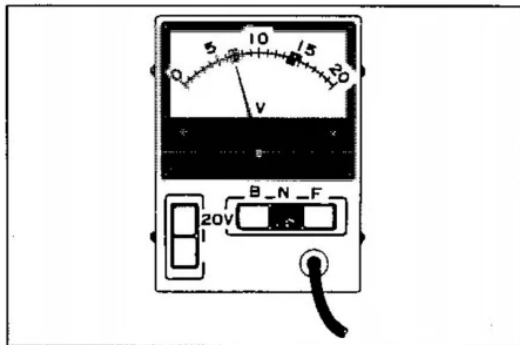

4. Check "N" terminal voltage.
Push "N" switch.
Maintain engine speed at approx. 1500 rpm. The pointer should be at a half of "B" terminal voltage.

Fig. 9-19

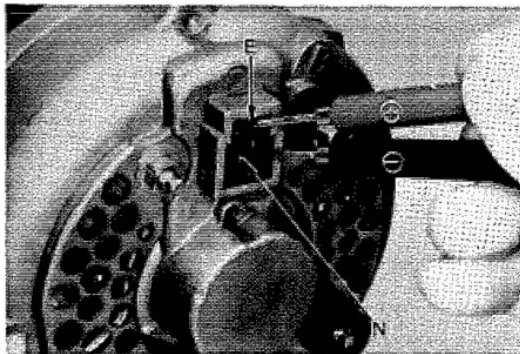

ALTERNATOR INSPECTION

1. Negative side rectifier short test.
Connect an ohmmeter (-) lead to N terminal and (+) lead to E terminal.
Meter should indicate infinity.

Fig. 9-20

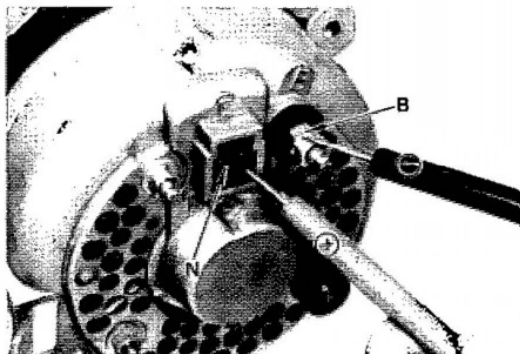

2. Positive side rectifier short test.
Connect an ohmmeter (-) lead to B terminal and (+) lead to N terminal.
Meter should indicate infinity.

Fig. 9-21

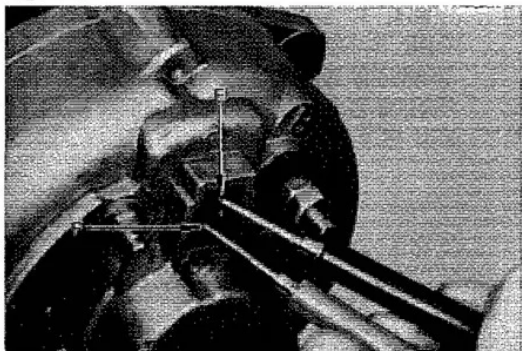

3. Check rotor coil resistance.
Resistance 5-9 Ω

Fig. 9-22

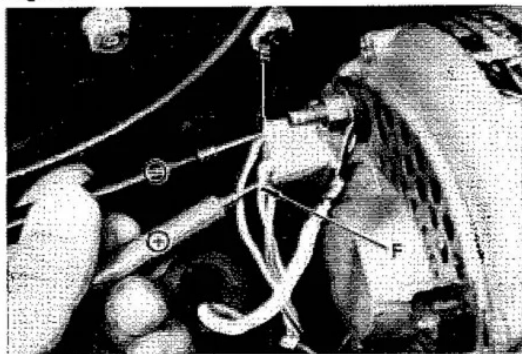

4. Turn ignition switch to ON position, and check if there is battery voltage at F terminal. If not, check ENGINE fuse.

ALTERNATOR (Conventional Type)

DISASSEMBLY

Disassemble in numerical order.

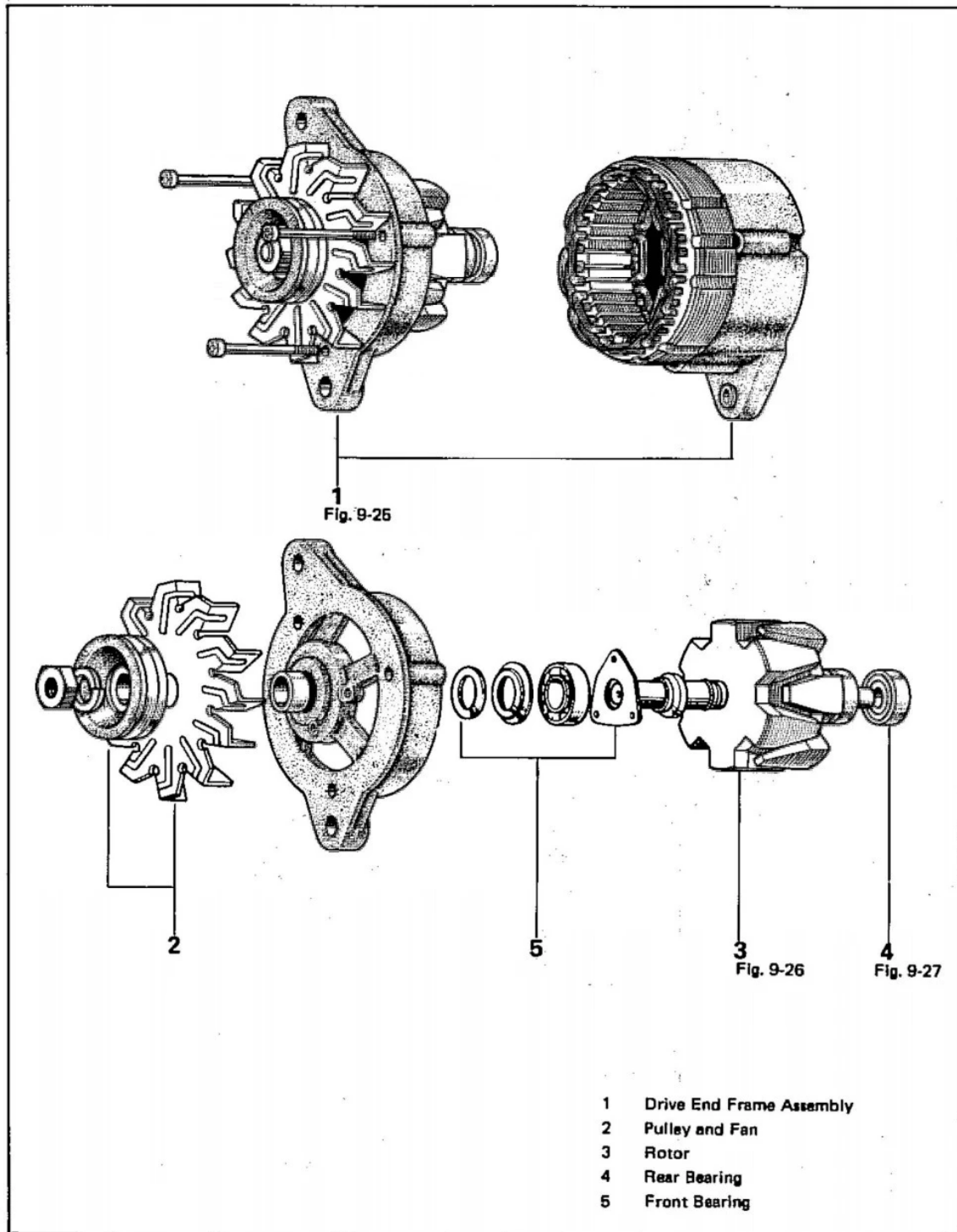

Fig. 9-23

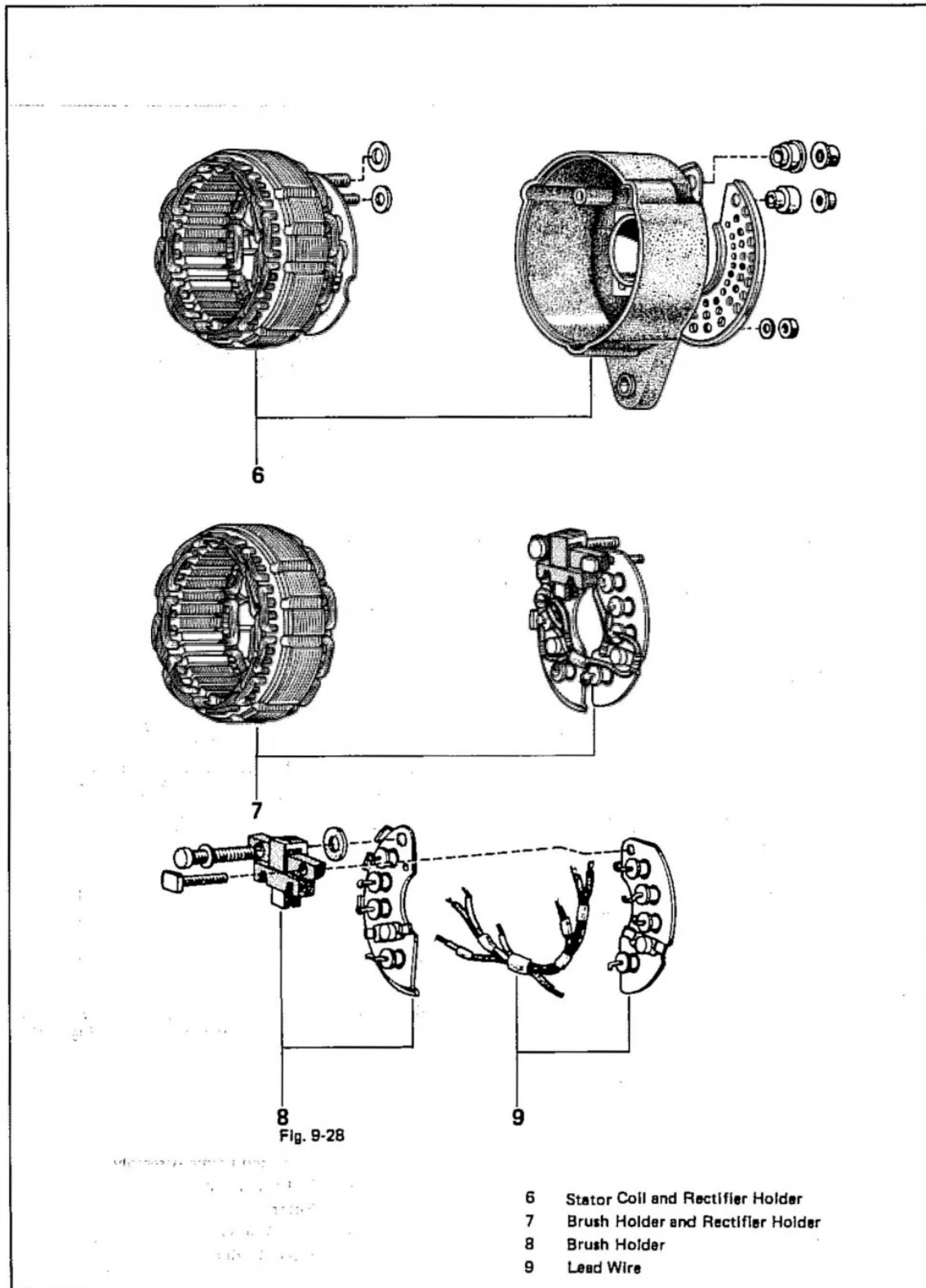
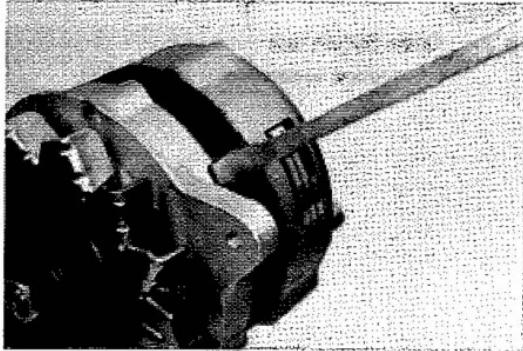

Fig. 9-24

Fig. 9-25



Pry drive end frame from stator.
Do not pry coil wires.

Fig. 9-26

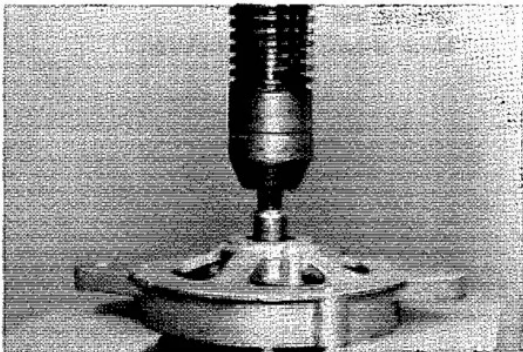

Remove rotor from drive end frame using a press.

Fig. 9-27

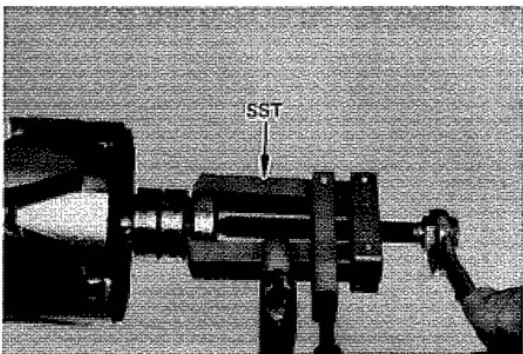

Remove rotor shaft rear bearing using SST [09286-46011].

Fig. 9-28

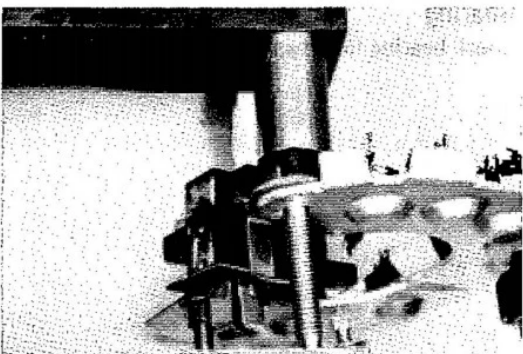

Remove brush holder assembly using a 10 mm socket wrench and vise.

Fig. 9-29

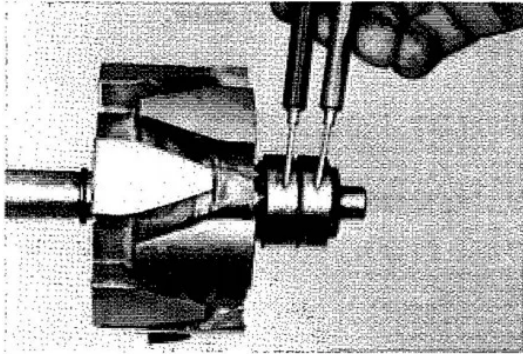

Fig. 9-30

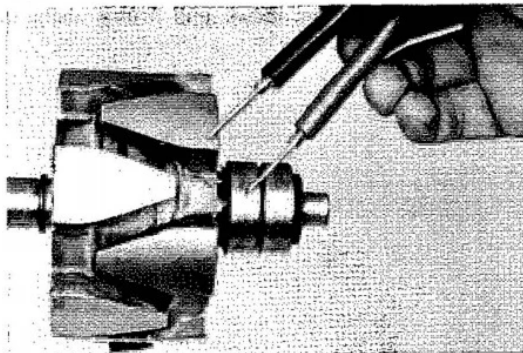

Fig. 9-31

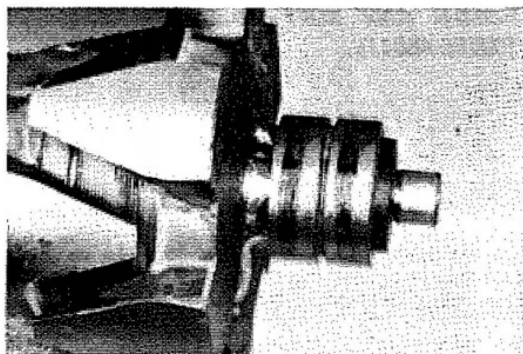

Fig. 9-32



INSPECTION AND REPAIR



Rotor

1. Open circuit test
Standard resistance 4.1-4.3Ω



2. Ground test
Meter should indicate infinity.



3. Check slip ring for being dirty or burnt.



Bearing

- Check bearing for wear or roughness.

Fig. 9-37

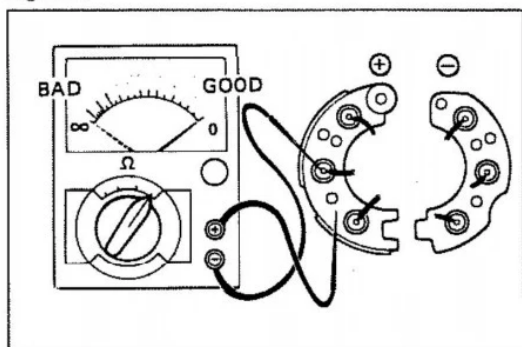
**Rectifier**

1. Rectifier holder positive side
Connect an ohmmeter (+) lead to the rectifier holder, and the (-) lead of the meter to the rectifier terminal. If there is no continuity, rectifier assembly must be replaced.

Fig. 9-38

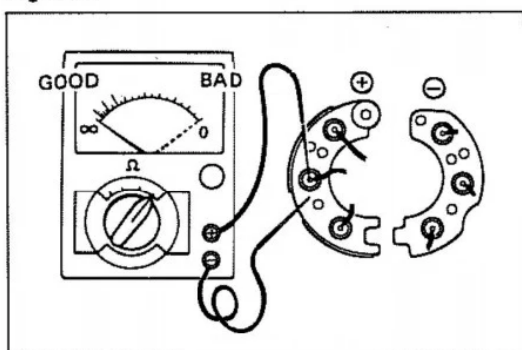

Reverse polarity of test leads and check again. If there is continuity, rectifier assembly must be replaced.

Fig. 9-39

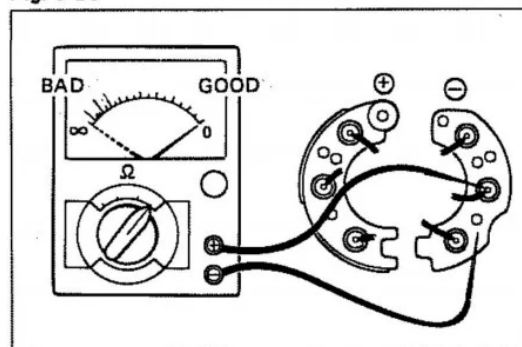

2. Rectifier holder negative side
Connect an ohmmeter (+) lead to the rectifier terminal, and the (-) lead of the meter to the rectifier holder. If there is no continuity, rectifier assembly must be replaced.

Fig. 9-40

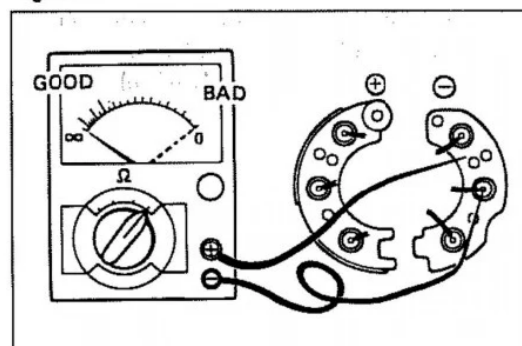

Reverse polarity of test leads and check again. If there is continuity, rectifier assembly must be replaced.

ASSEMBLY

Assemble in numerical order.

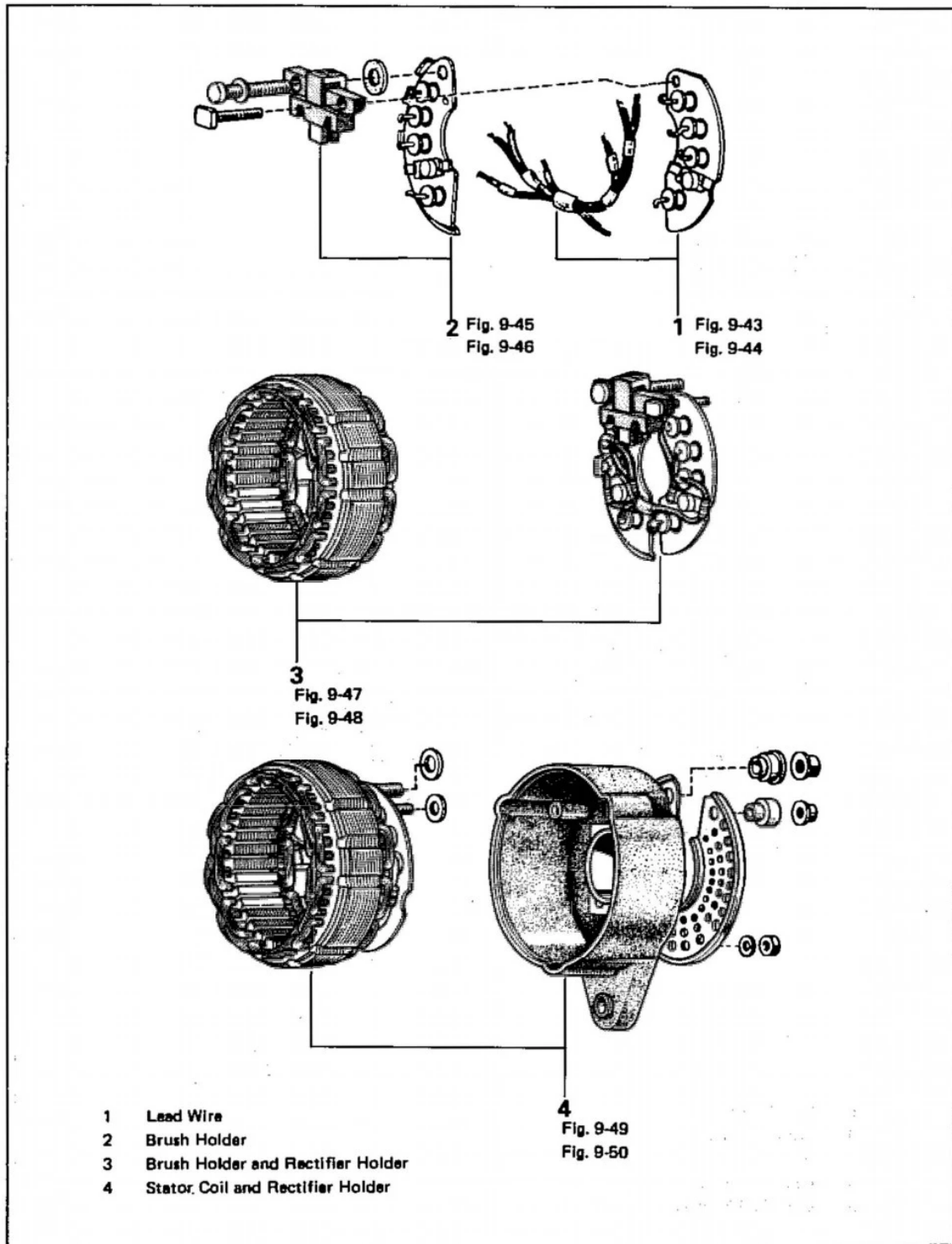

Fig. 9-41

2-3.plt

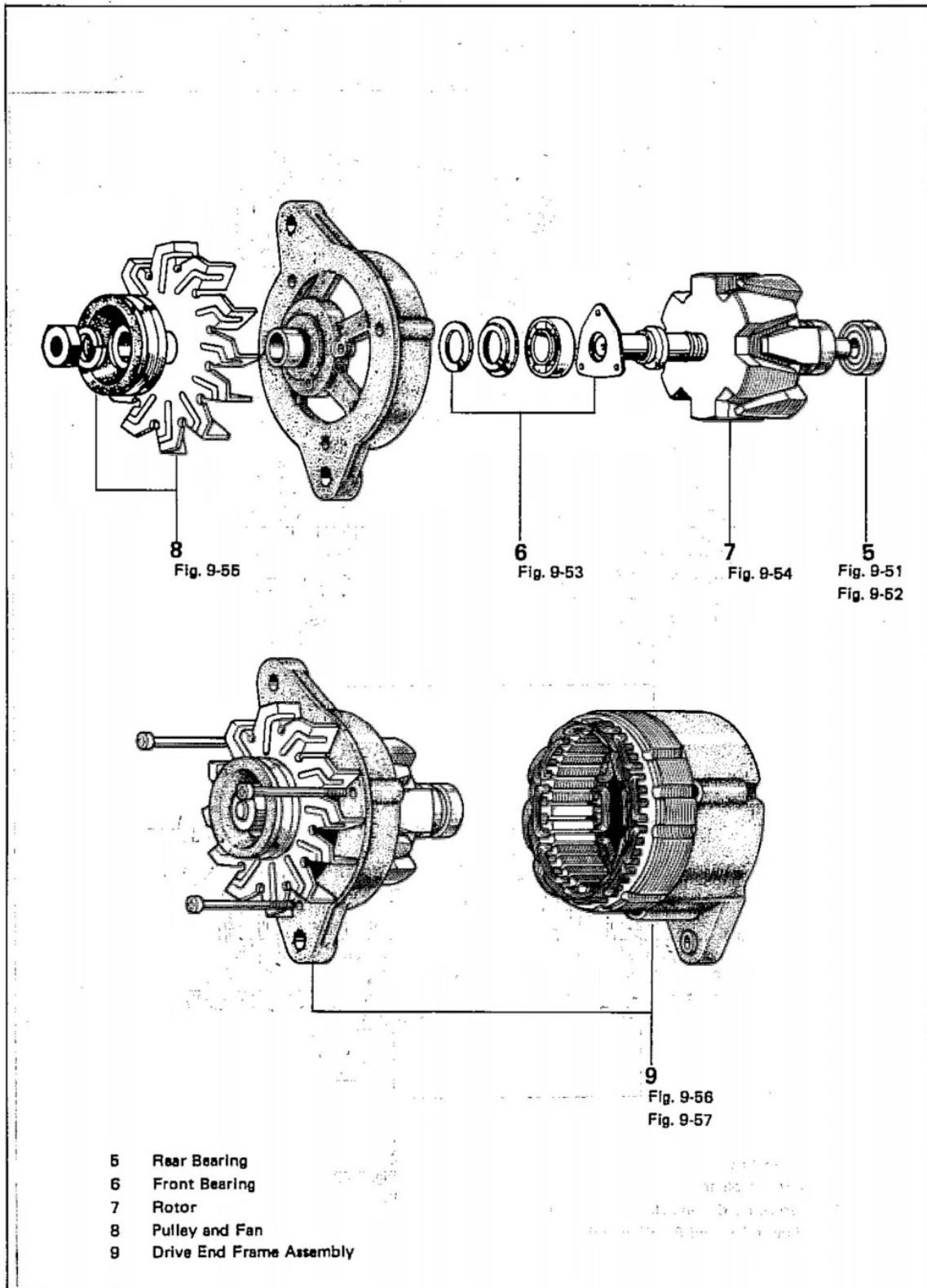
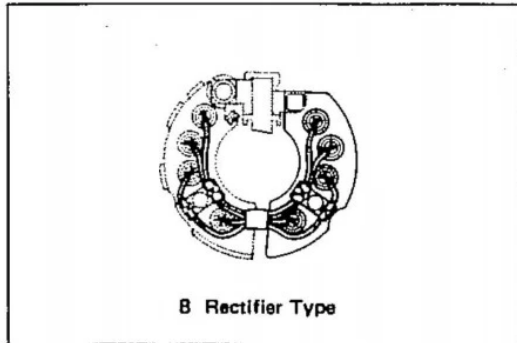

Fig. 9-42

Fig. 9-43



Solder negative side rectifiers.

Fig. 9-44

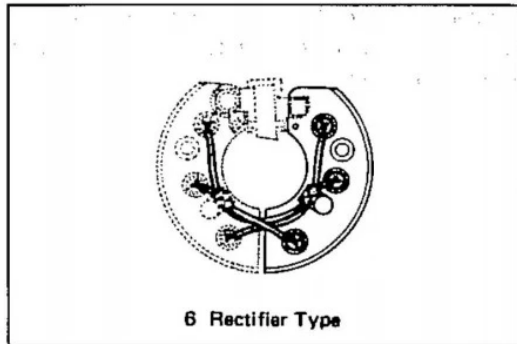
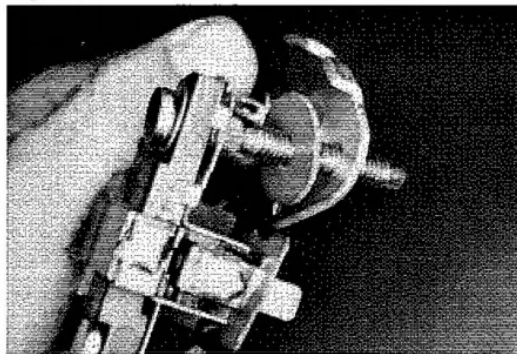
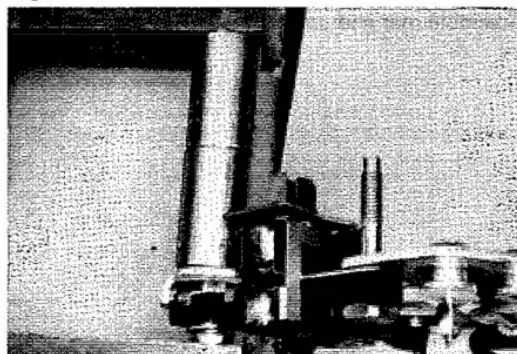

Fig. 9-45



Insert insulator between positive rectifier holder and brush holder.

Fig. 9-46



Install brush holder onto rectifier holder using socket wrench and a vise.

Fig. 9-47

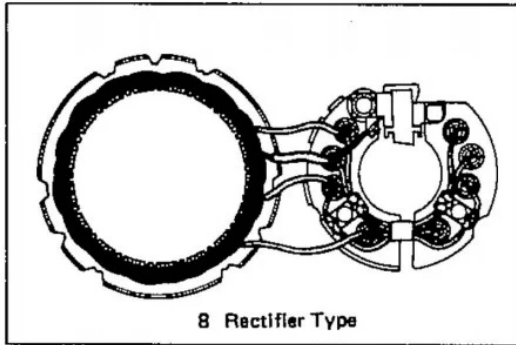

Connect stator coil "N" lead onto (+) rectifier terminal and brush holder terminal.
(8 Rectifier Type)

Fig. 9-48

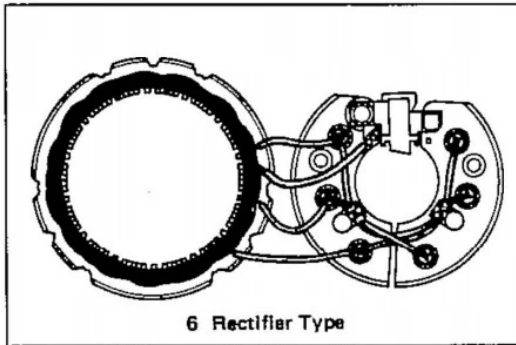

Connect stator coil "N" lead onto brush holder terminal, and solder each stator lead and rectifier lead to positive rectifier.

Fig. 9-49

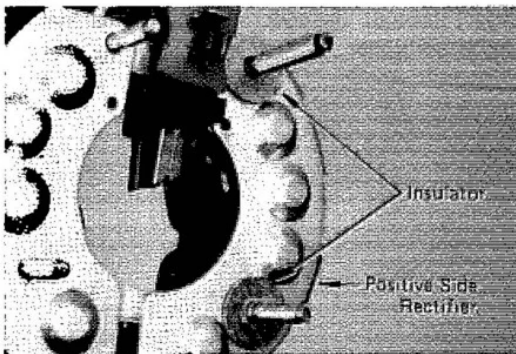

Assemble rear end frame and rectifier holder with insulators.

Fig. 9-50

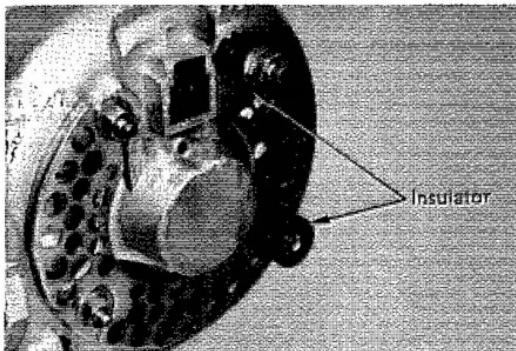

Assemble rear end cover with insulators.

Fig. 9-51



Install rear bearing facing its sealed side forward.

Fig. 9-52

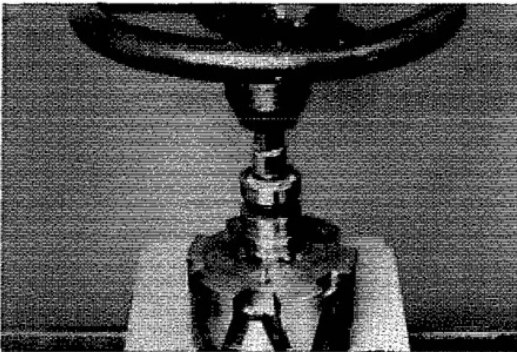

Press rear bearing onto rotor shaft, using a press.

Fig. 9-53

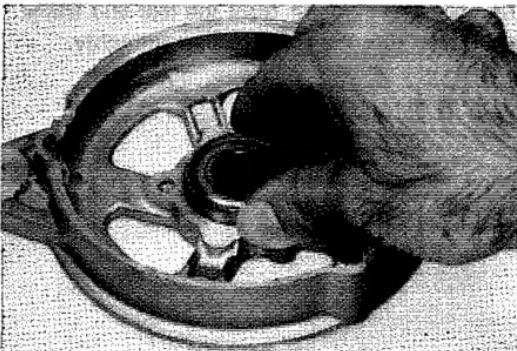

Install the front bearing facing its sealed side rearward.

Fig. 9-54

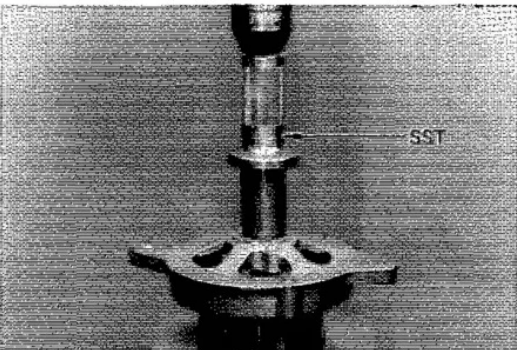

Press drive end frame assembly onto rotor shaft, using SST [09325-12010].

Fig. 9-55

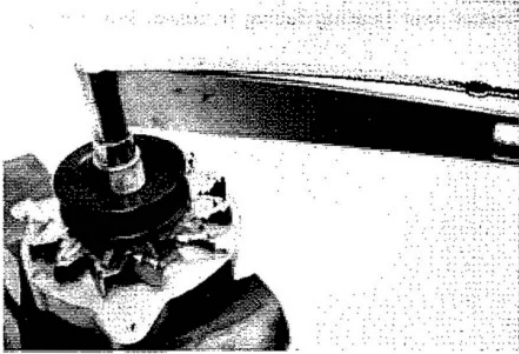

Tighten nut to specified torque.

Torque 5-6.5 kg-m (36-47 ft-lb)

Fig. 9-56

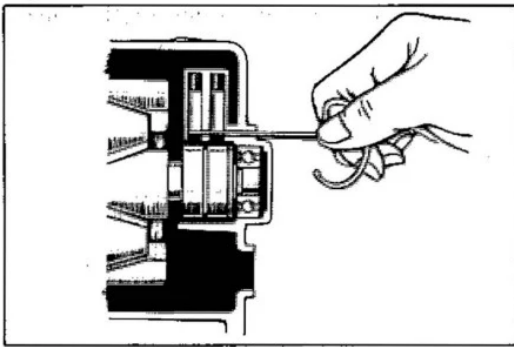

Push in brushes and temporarily lock in place with wire inserted through access hole in end frame.

Position lead wires to clear rotor.

Fig. 9-57

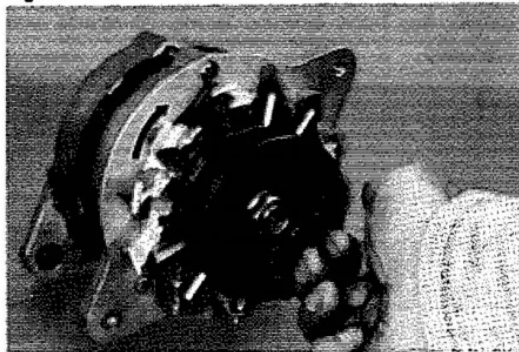

Remove locking wire from the rear end frame and make sure the rotor rotates smoothly.

ALTERNATOR (Heavy Duty Type) DISASSEMBLY

Disassemble in numerical order.

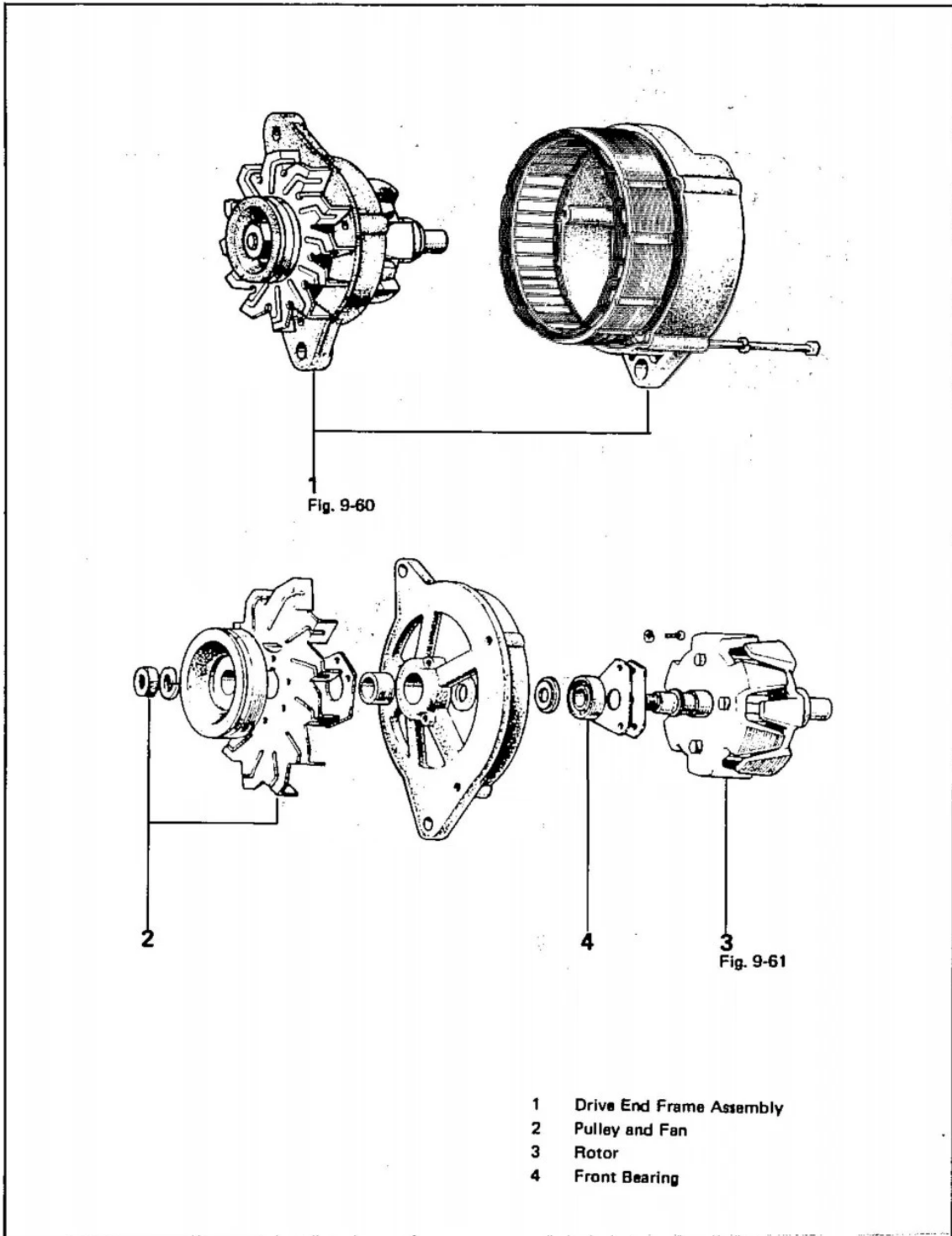

Fig. 9-58

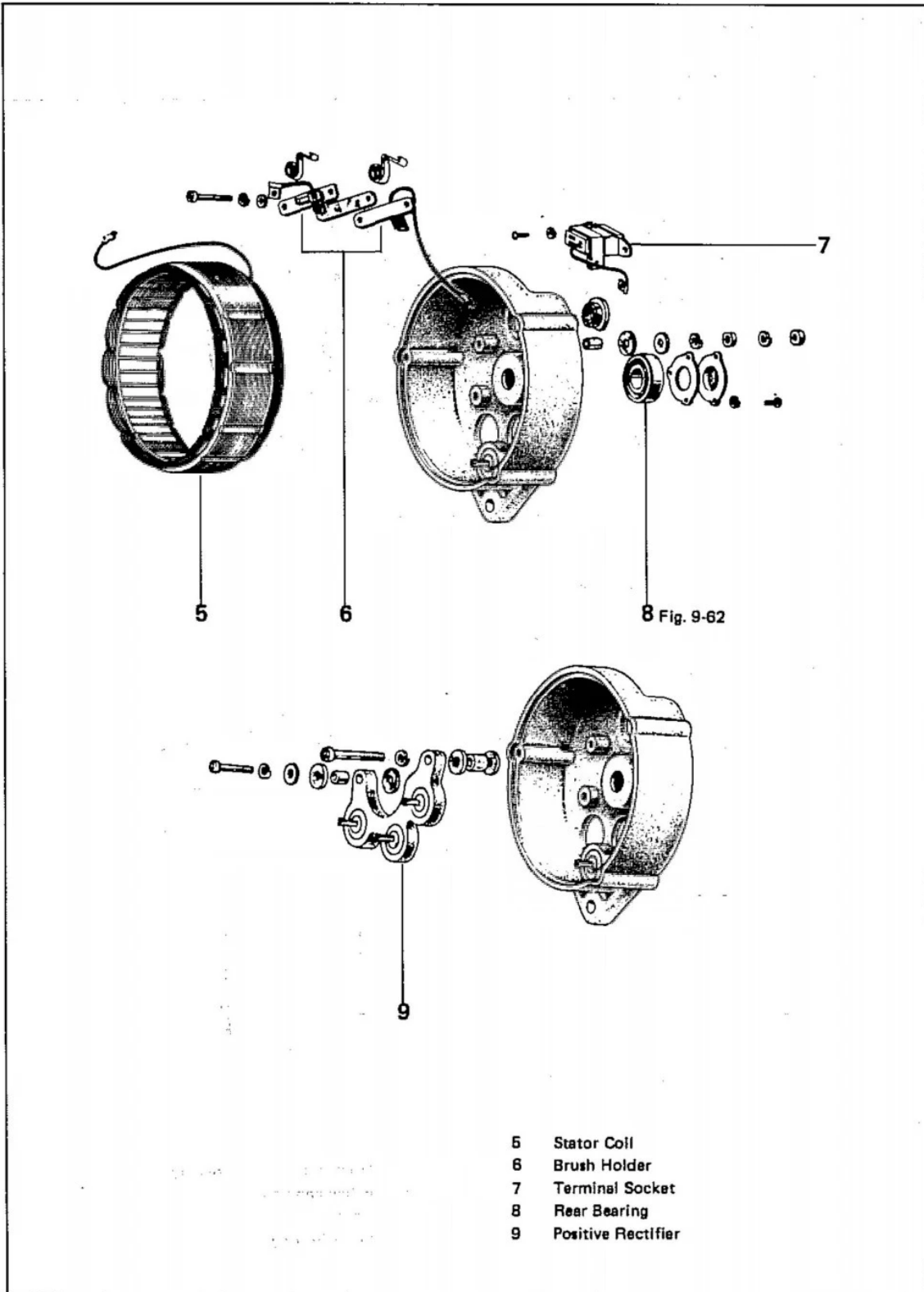
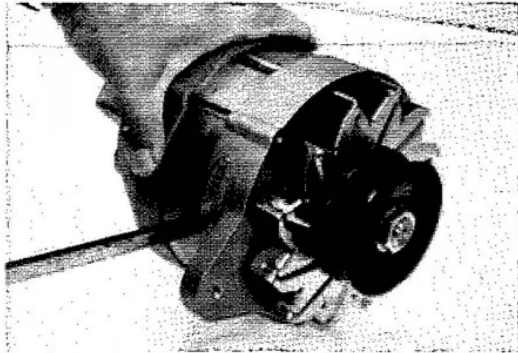

Fig. 9-59

Fig. 9-60



Pry drive end frame from stator.
Do not pry coil wires.

Fig. 9-61

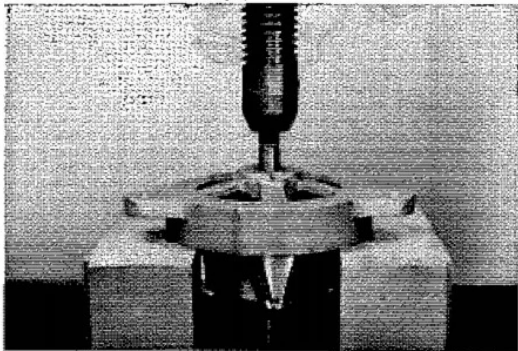

Remove rotor from drive end frame using a press.

Fig. 9-62

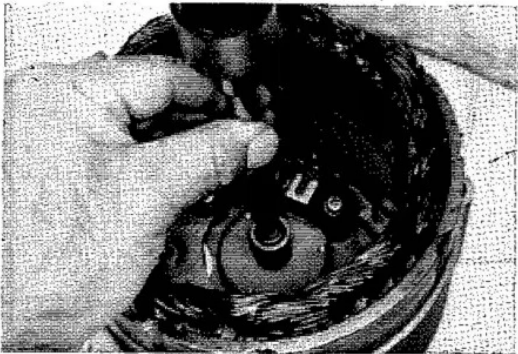

Tap out rear bearing, using a socket wrench.

Fig. 9-63

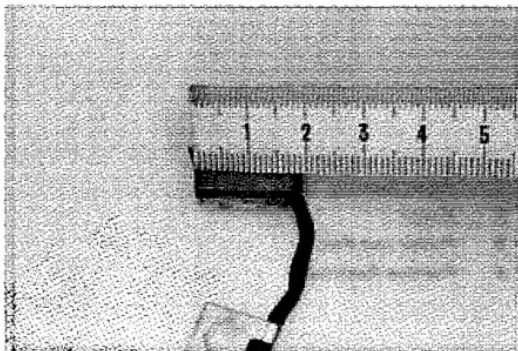

INSPECTION

Check brush length and replace if below the limit.

| | |
|-----------------|--------------------------|
| Standard | 18.5 mm (0.73 in) |
| Limit | 8 mm (0.31 in) |

For other items, see INSPECTION section of Conventional Type Alternator.

ASSEMBLY

Assemble in numerical order.

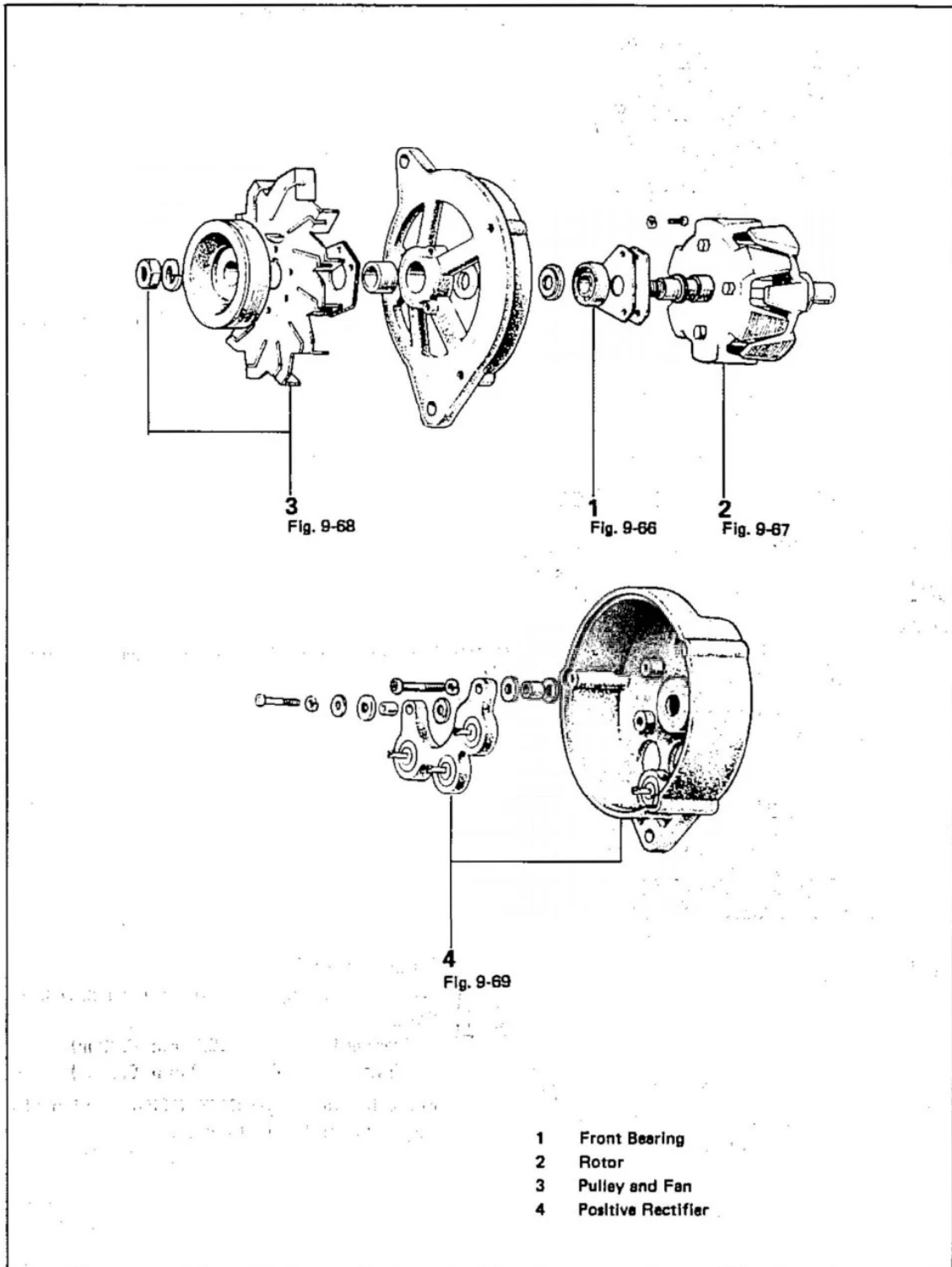

Fig. 9-64

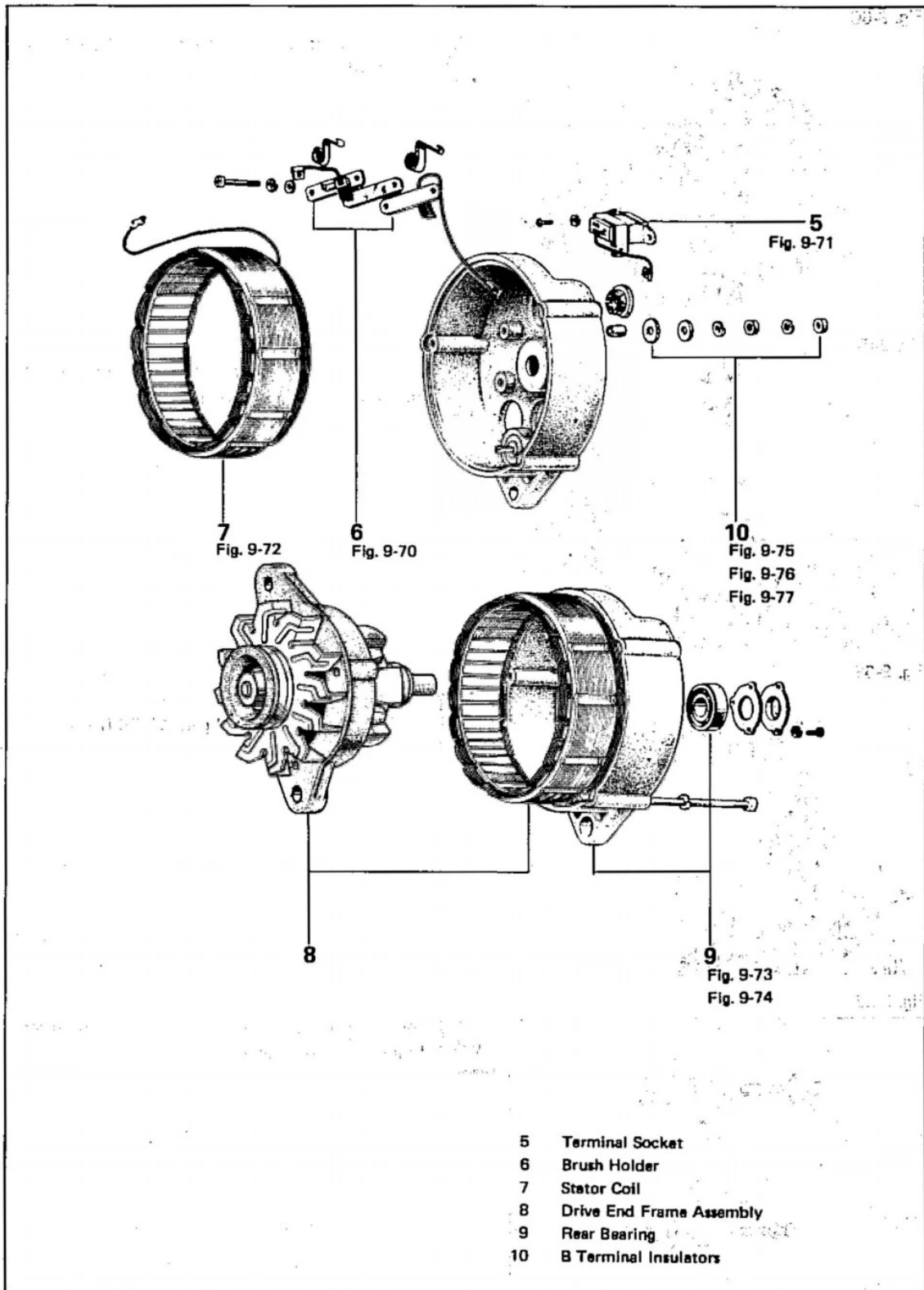
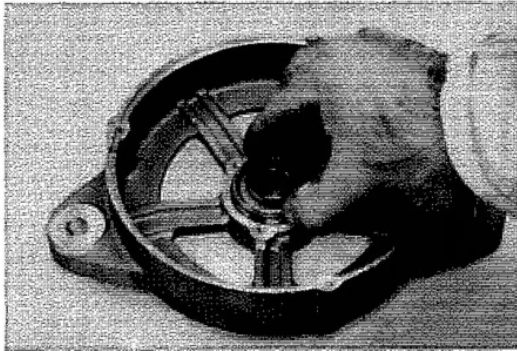

Fig. 9-65

Fig. 9-66



Install front bearing facing its sealed side rearward.

Fig. 9-67

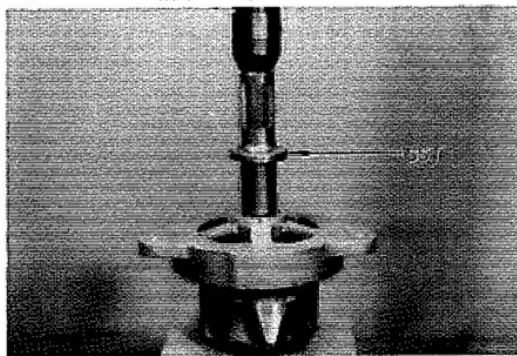

Press drive end frame assembly onto shaft, using SST [09325-12010].

Fig. 9-68

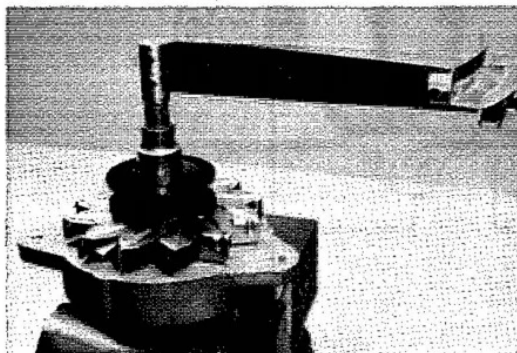

Tighten nut to specified torque.
Torque 3.5-8 kg-m (25-58 ft-lb)

Fig. 9-69

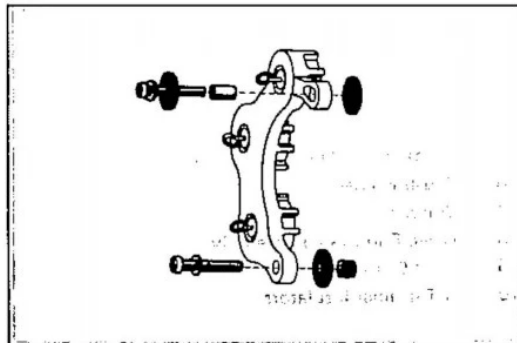

Insert insulators between positive rectifier holder and end frame.

Fig. 9-70

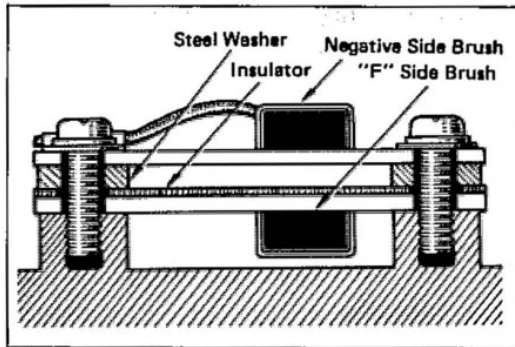

Assemble brush holder with insulators onto rear end frame as shown. Have the brushes lifted up.

Fig. 9-71



Insert the "F", "N" and "E" lead terminals into the connector socket as shown.

Fig. 9-72

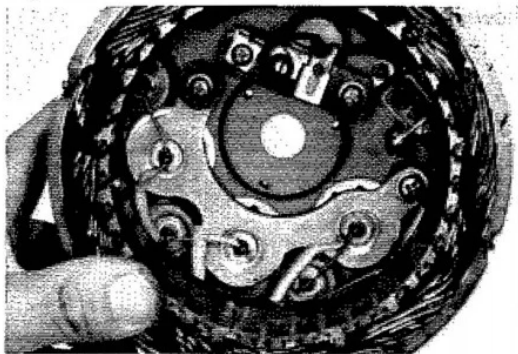

Connect stator coil leads onto positive and negative side rectifier terminals.

Fig. 9-73

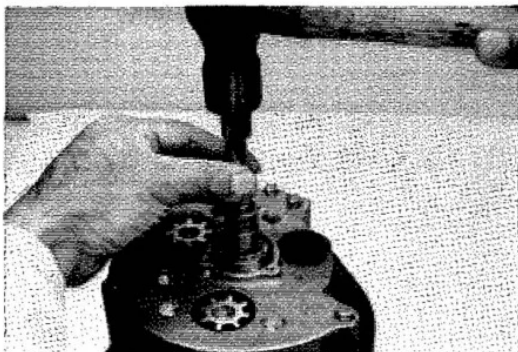

Install rear bearing, facing its sealed side front.

Fig. 9-74

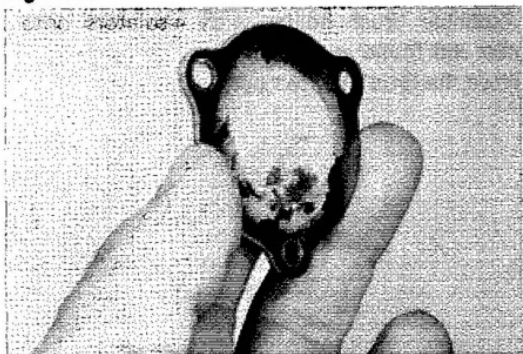

Install rear bearing cover not more than half full of grease.

Fig. 9-75

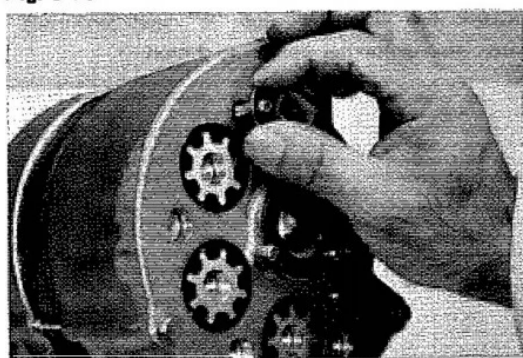

Assemble insulators onto B terminal bolt.

Fig. 9-76

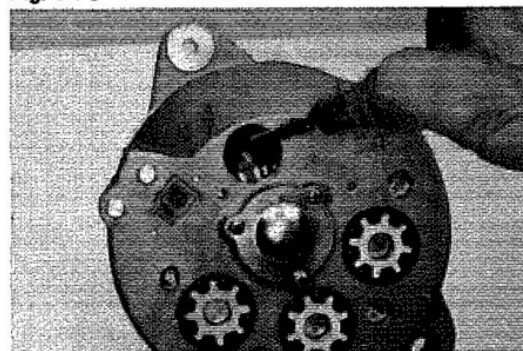

Lower brushes and hold with springs.

Fig. 9-77

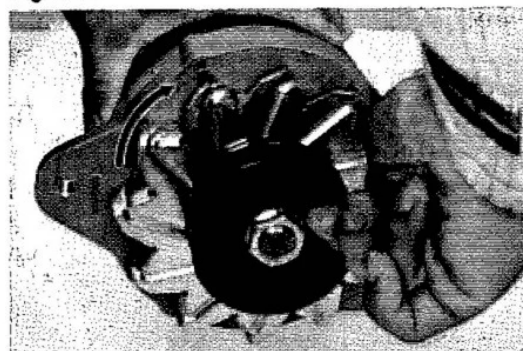

Make sure the rotor rotates smoothly.

ALTERNATOR (With Vacuum Pump Type) DISASSEMBLY

Disassemble in numerical order.

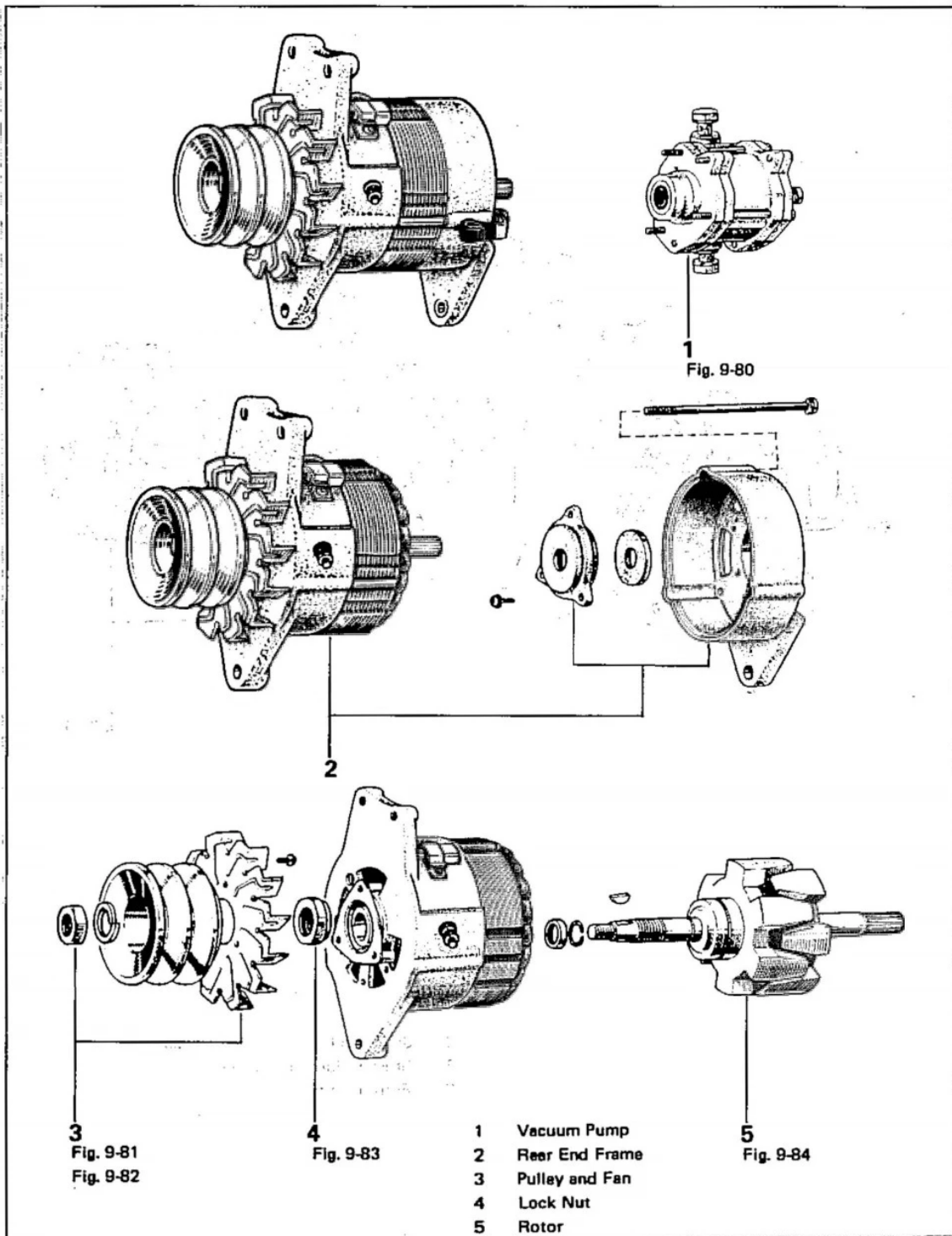
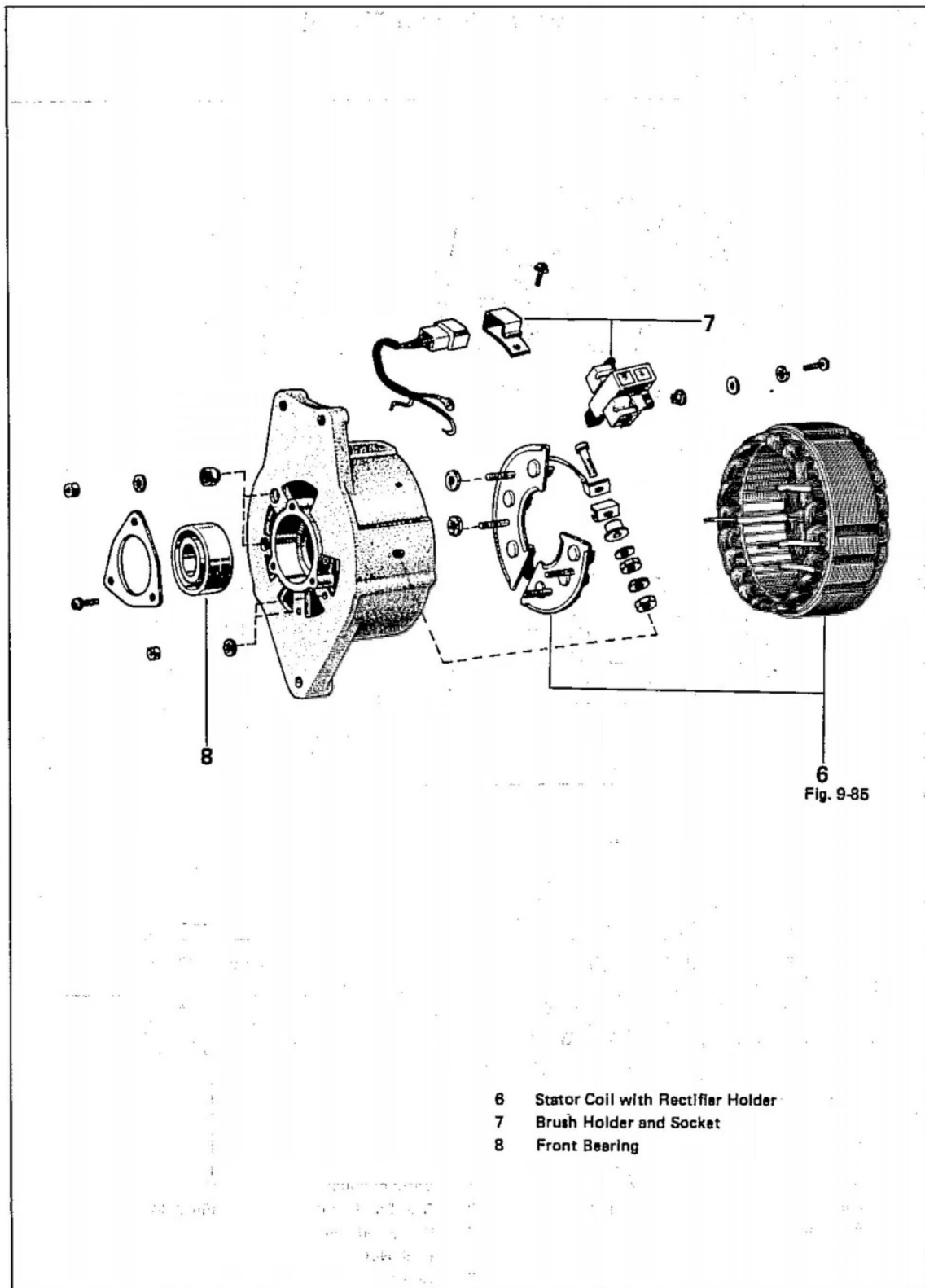

Fig. 9-78

97-9.gif



- 6 Stator Coil with Rectifier Holder
- 7 Brush Holder and Socket
- 8 Front Bearing

Fig. 9-79

Fig. 9-80

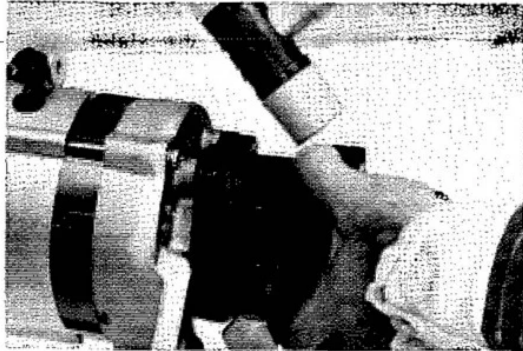

Lightly tap the vacuum pump with a plastic hammer to remove it.

Fig. 9-81

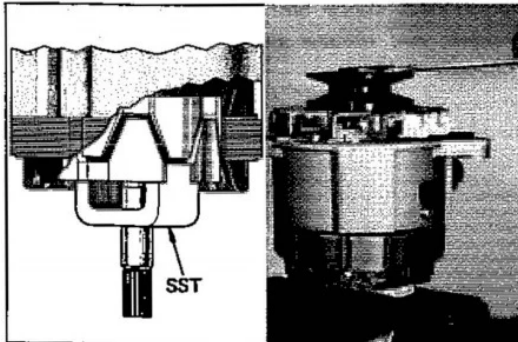

Secure SST [09841-56010] in a vise, and secure the rotor core onto the SST.

– Note –

Take care not to damage the stator coil.

Loosen pulley nut.

Fig. 9-82

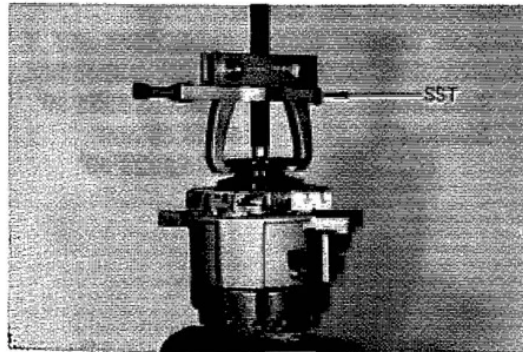

Remove pulley with fan, using SST [09950-20014].

Fig. 9-83

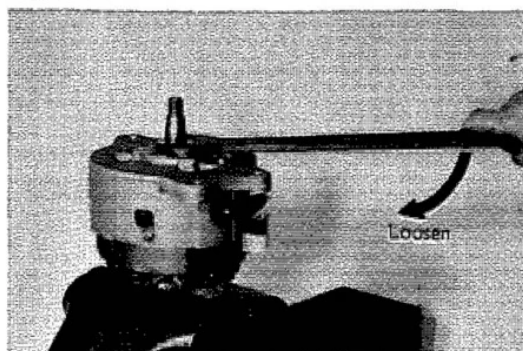

Remove bearing lock nut.

The lock nut has left-hand thread.

Fig. 9-84

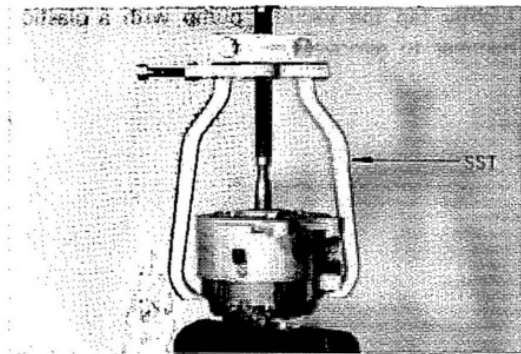

Remove rotor with SST [09950-20013].
Take care not to damage the stator coil.

Fig. 9-85

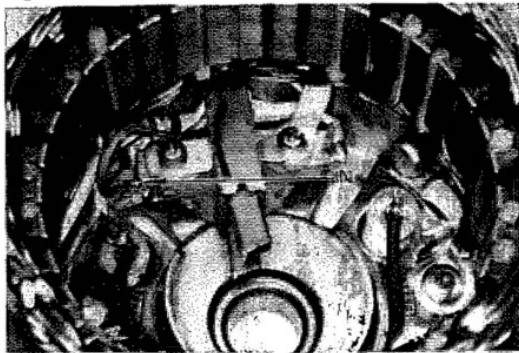

Disconnect stator coil "N" lead from brush holder, and remove stator coil with rectifier holders.

Fig. 9-86

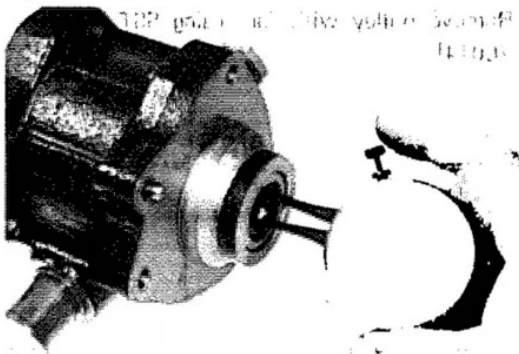
**INSPECTION**

Inspect oil seal and bearing.
Measure vacuum pump bearing bore and if exceeds limit, replace vacuum pump assembly.

| | |
|------------|--------------------------------------|
| Bore limit | 16.14 mm (0.6354 in) |
| Standard | 16.04-16.06 mm (0.6315-0.6323 in) |

**FOR OTHER ITEMS,
SEE INSPECTION SECTION
OF CONVENTIONAL TYPE
ALTERNATOR.**

ASSEMBLY

Assemble in numerical order.

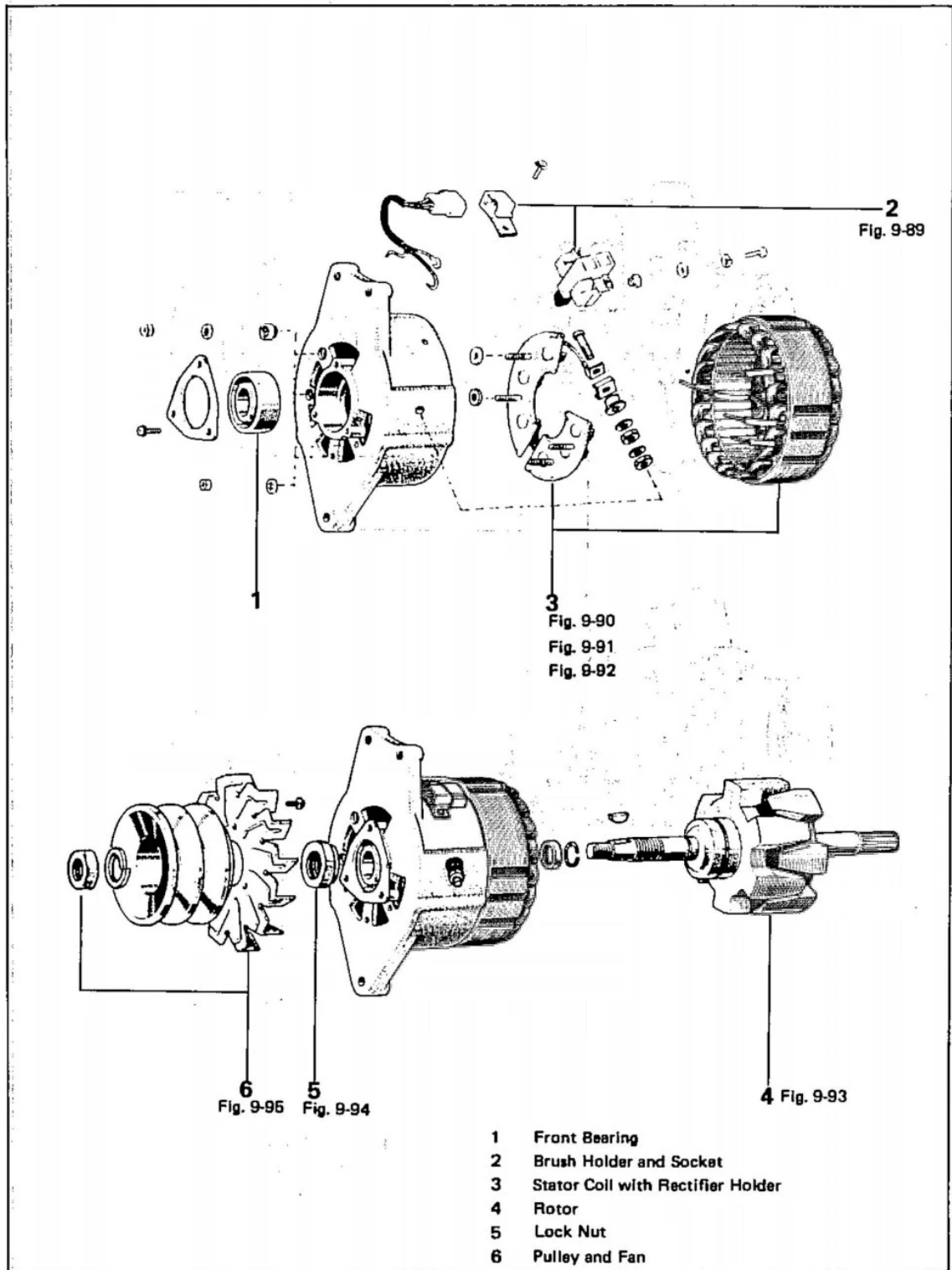

Fig. 9-87

80-e 37

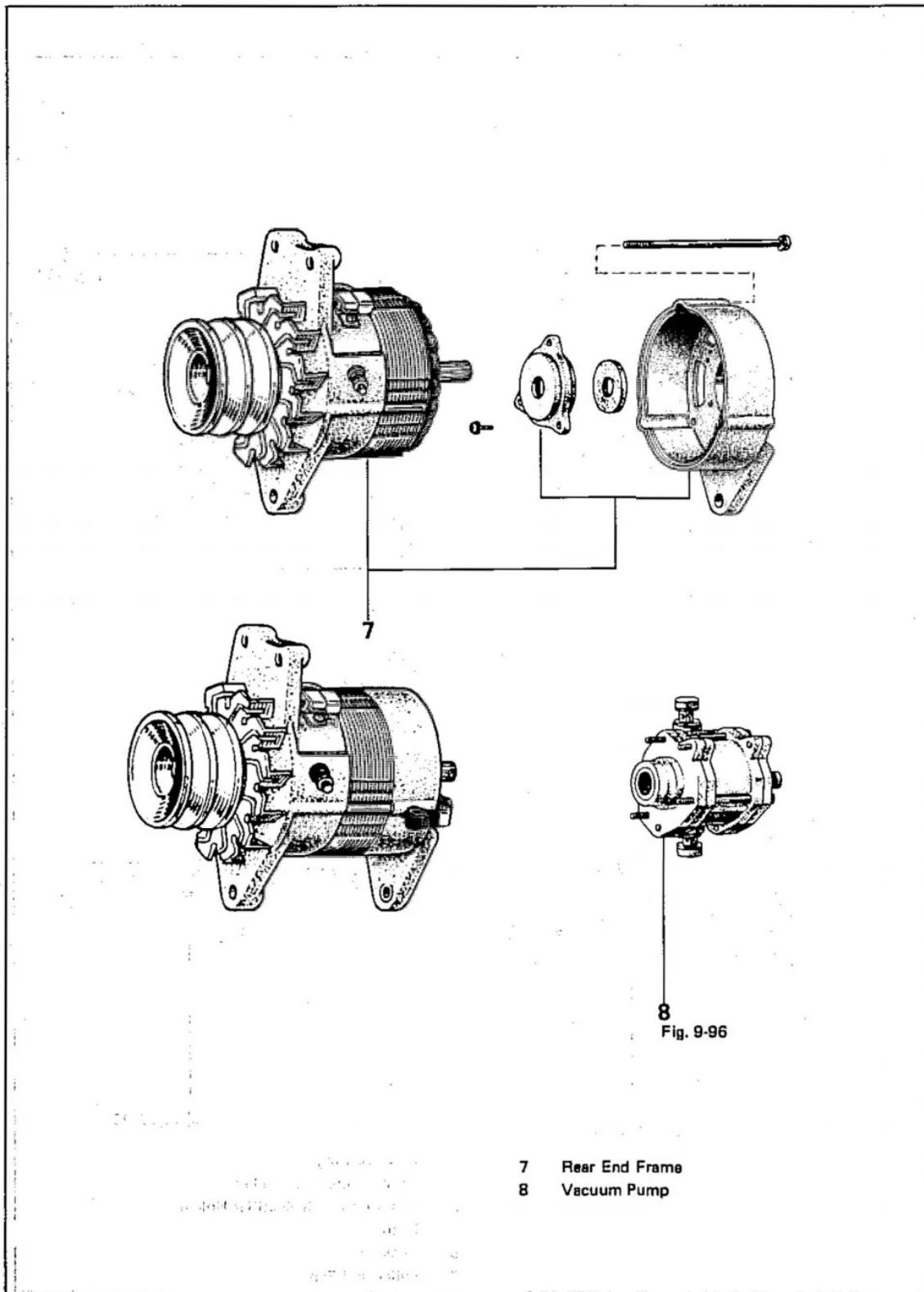
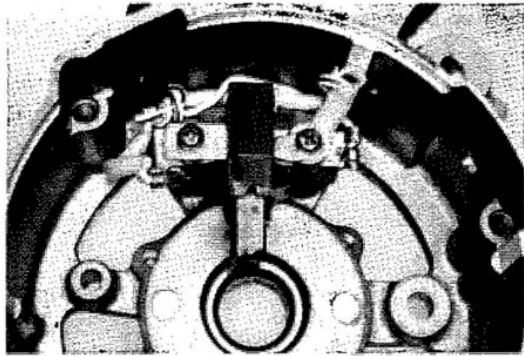

Fig. 9-88

Fig. 9-89



Tie the lead wires and solder the "F" terminal onto the brush holder. Connect "E" terminal.

Fig. 9-90

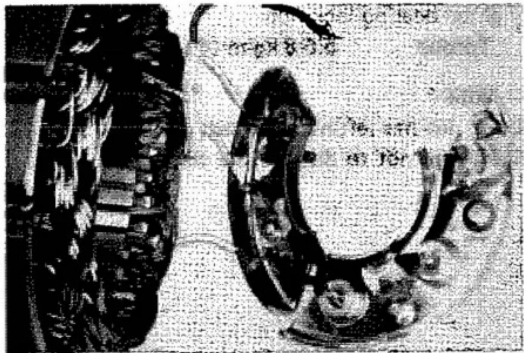

Solder rectifier leads onto stator coil.

Fig. 9-91

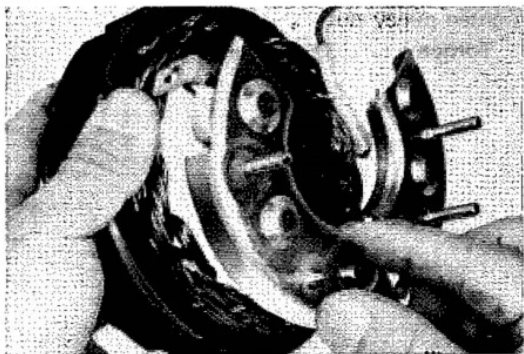

Assemble the rectifier holders and stator coil with insulators onto the drive end frame. Position insulators between B terminal and drive end frame, then install B terminal bolt.

Fig. 9-92

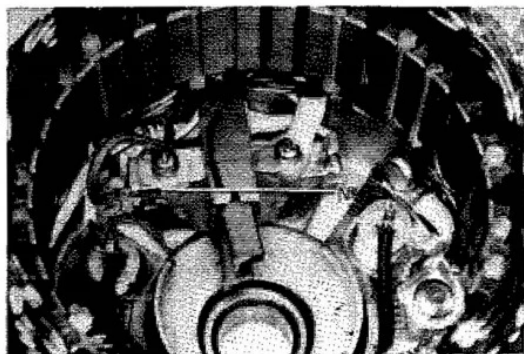

Solder the stator coil "N" lead and socket "N" lead onto brush holder.

Fig. 9-93

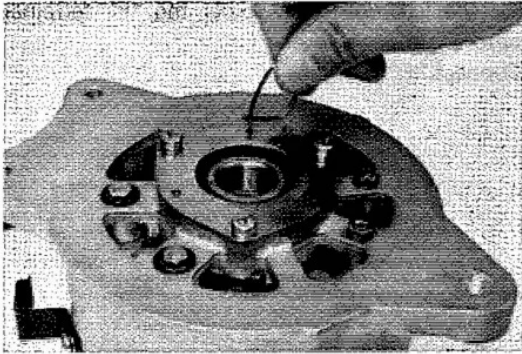

Lift up brushes and lock with a wire.

Fig. 9-94

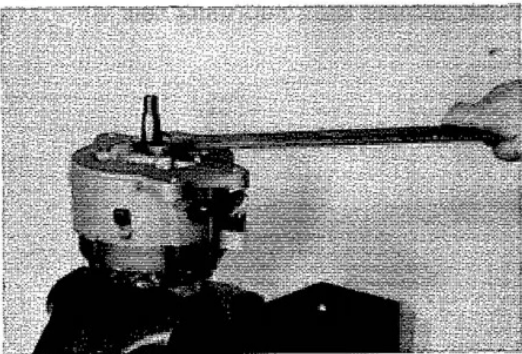

Tighten bearing lock nut.

Torque 5.6-8 kg-m (41-58 ft-lb)

— Note—

Lock nut has left-hand thread.

Take care not to damage the stator coil.

Fig. 9-95

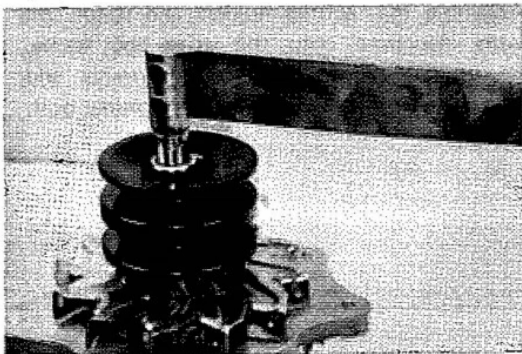

Tighten pulley nut.

Torque 3.5-8 kg-m (25-58 ft-lb)

Fig. 9-96

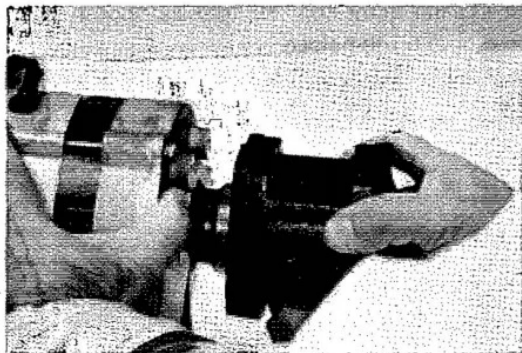

Align the vacuum pump rotor spline hole against the rear cover hole and then fit in the alternator rotor shaft spline.

ALTERNATOR REGULATOR

Fig. 9-97

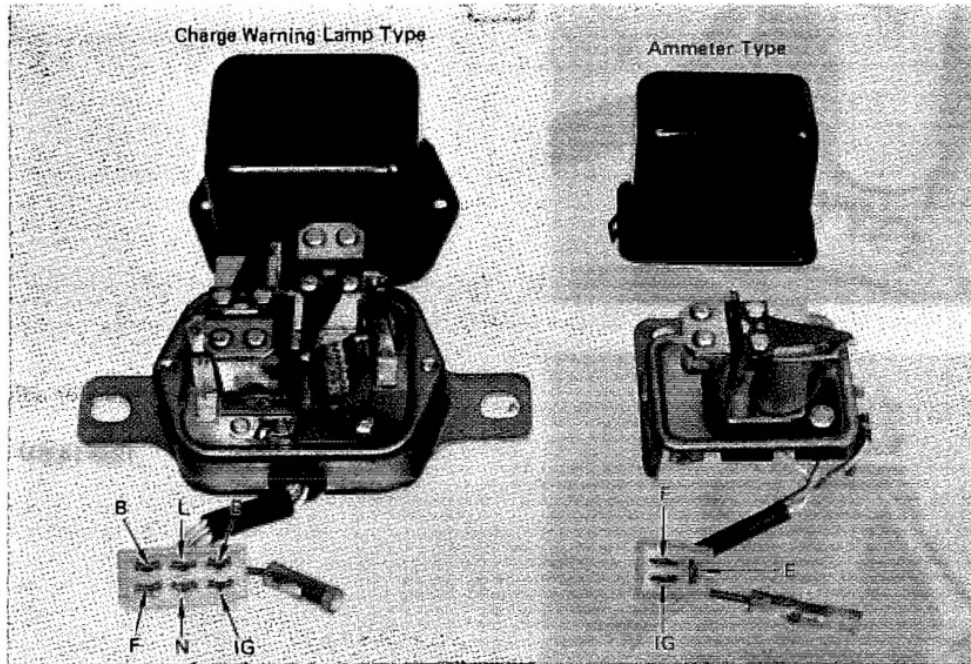
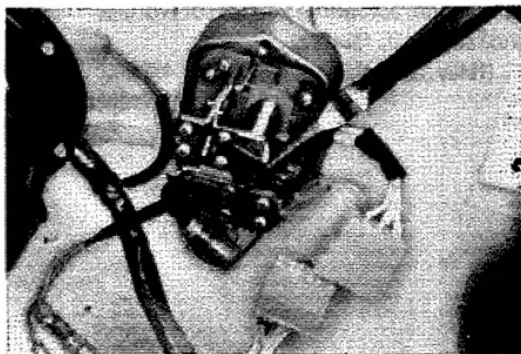

Fig. 9-98



Fig. 9-99



INSPECTION AND ADJUSTMENT



Check connector fitting condition before inspecting regulator.



Always be sure to have the regulator connector pulled out when inspecting and adjusting.

Fig. 9-100

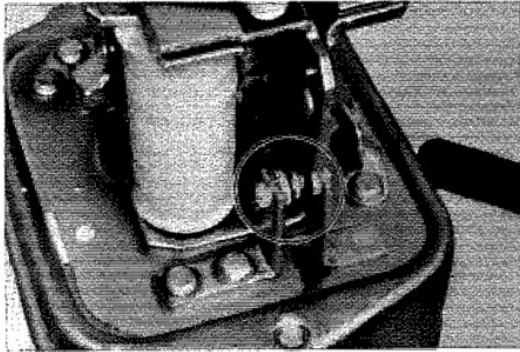

Inspect each point surface for burn or excessive damage. Replace if defective.

Fig-101

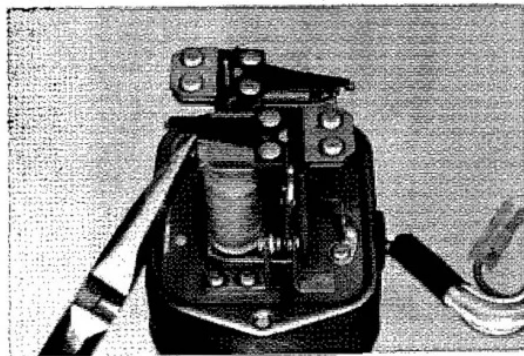

Voltage adjustment

To adjust, bend the voltage regulator adjusting arm.

Regulated voltage

13.8-14.8V

Fig. 102

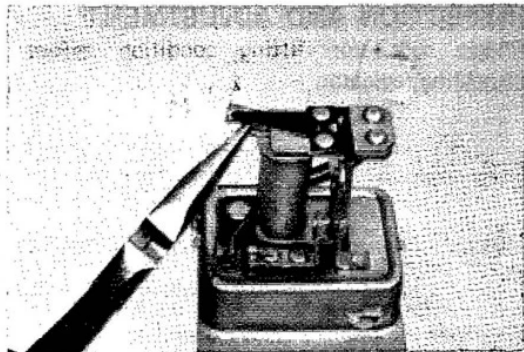
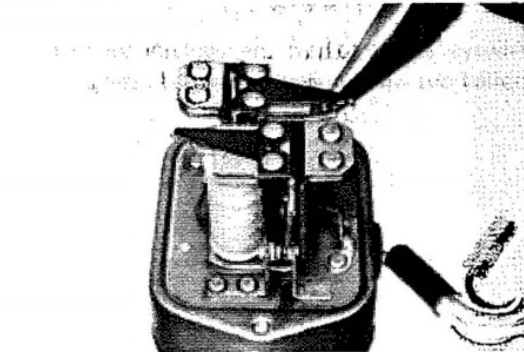

Fig. 9-103



Voltage relay adjustment

Check the actuating voltage of voltage relay and adjust if faulty.

Relay actuating voltage

4.5-5.8 V

(Reference only)

Fig. 9-104

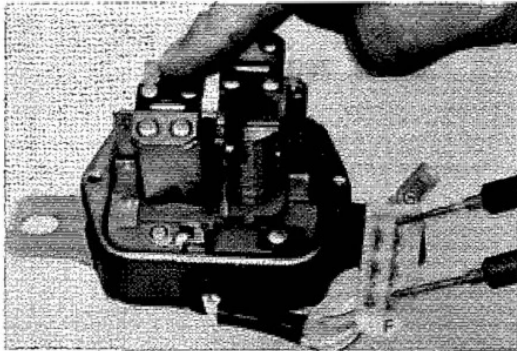

Resistance measurement between terminals.
Charge warning light type.

IG-F

| | | |
|-------------------|-----------|-------------|
| Voltage Regulator | At rest | 0Ω |
| | Pulled in | approx. 11Ω |

Fig. 9-105

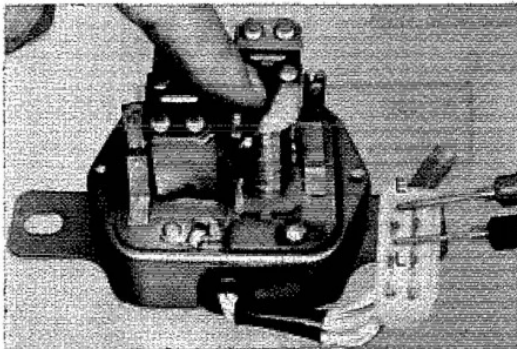

L-E

| | | |
|---------------|-----------|--------------|
| Voltage Relay | At rest | 0Ω |
| | Pulled in | approx. 100Ω |

Fig. 9-106

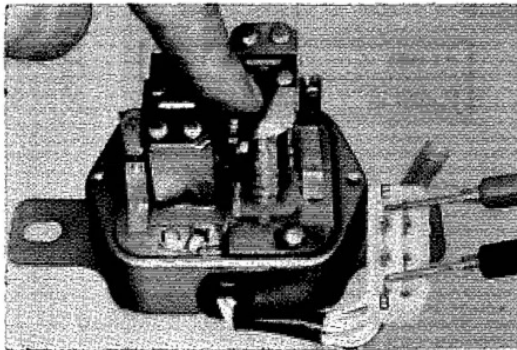

B-E

| | | |
|---------------|-----------|--------------|
| Voltage Relay | At rest | infinity |
| | Pulled in | approx. 100Ω |

Fig. 9-107

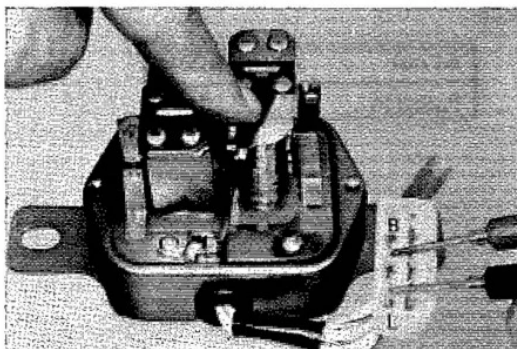

B-L

| | | |
|---------------|-----------|----------|
| Voltage Relay | At rest | infinity |
| | Pulled in | 0Ω |

Fig. 9-108

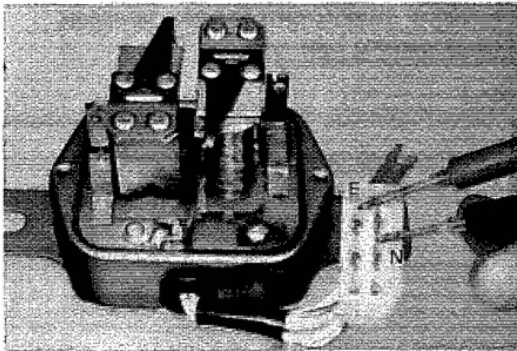

N-E

approx. 25Ω

Fig. 9-109

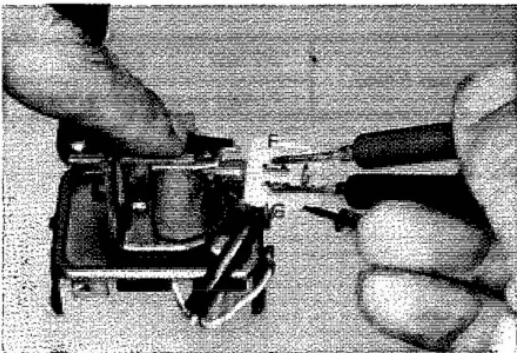

Ammeter type

IG-F

| | |
|-----------|--------------------|
| At rest | 0Ω |
| Pulled in | approx. 11Ω |

Fig. 9-110

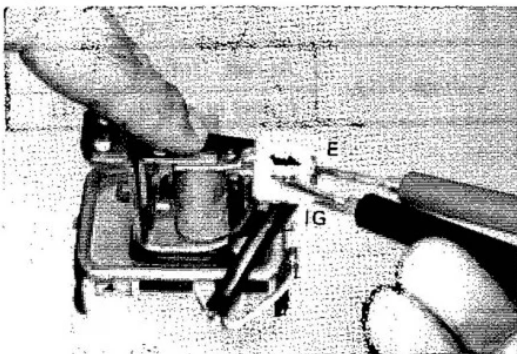

IG-E

| | |
|-----------|---------------------|
| At rest | approx. 100Ω |
| Pulled in | infinity |

Fig. 9-111

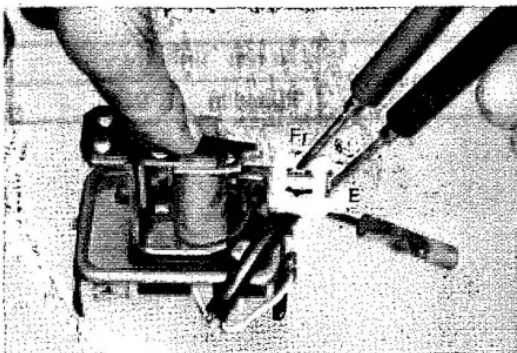









F-E

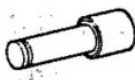

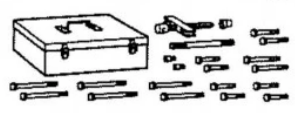

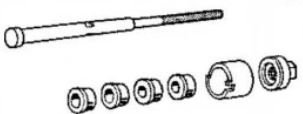



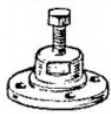

| | |
|-----------|---------------------|
| At rest | approx. 100Ω |
| Pulled in | 0Ω |

SST & SPECIFICATIONS

| | Page |
|---|-------------|
| SST (SPECIAL SERVICE TOOL) | 10-2 |
| STANDARD BOLT TIGHTENING TORQUE..... | 10-4 |
| MAIN PARTS TIGHTENING TORQUE..... | 10-5 |
| ENGINE SPECIFICATIONS | 10-5 |
| SERVICE SPECIFICATIONS..... | 10-6 |

SST (SPECIAL SERVICE TOOL)

| Illustration | Tool Number | Tool Name |
|---|-------------|---|
|  | 09081-00011 | Alternator Checker |
|  | 09201-31010 | Valve Stem Oil Seal Replacer |
|  | 09201-60011 | Valve Stem Guide Remover & Replacer |
|  | 09202-43012 | Valve Spring Compressor |
|  | 09213-60016 | Crankshaft Pulley & Gear Puller |
|  | 09214-60010 | Crankshaft Pulley & Gear Replacer |
|  | 09215-60010 | Camshaft Bearing Remover & Replacer |
|  | 09222-30010 | Connecting Rod Bushing Remover & Replacer |
|  | 09223-60010 | Crankshaft Rear Oil Seal Replacer |
|  | 09228-44010 | Oil Filter Wrench |
|  | 09235-60010 | Water Pump Pulley Seat Puller |

| Illustration | Tool Number | Tool Name |
|---|-------------|--|
|  | 09236-36010 | Water Pump Overhaul Tool (For Fluid Coupling Service) |
|  | 09238-40010 | Water Pump Bearing Remover & Replacer |
|  | 09240-00014 | Carburetor Adjusting Gauge Set |
|  | 09240-00020 | Wire Gauge Set |
|  | 09286-46011 | Injection Pump Spline Shaft Puller (For Alternator Service) |
|  | 09303-55010 | Input Shaft Front Bearing Puller |
|  | 09304-47010 | Input Shaft Front Bearing Replacer |
|  | 09325-12010 | Transmission Oil Plug (For Alternator Service) |
|  | 09515-35010 | Rear Wheel Bearing Replacer (For Crankshaft Front Oil Seal Installation) |
|  | 09841-56010 | Alternator Stand |
|  | 09860-11011 | Carburetor Driver Set |

STANDARD BOLT TIGHTENING TORQUE

STANDARD BOLT CLASSIFICATION

91111-40620 — Parts Number
 — Length of Bolt: 20 mm
 — Basic Major Dia. of Thread: 6 mm
 — Bolt Head Mark*

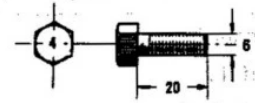

* Bolt Head Mark has the following indications.

STANDARD BOLT TIGHTENING TORQUE

| Class | Basic Dia. | Pitch | Standard Torque | | Torque Limit | |
|-------|------------|------------|-----------------|---------|--------------|------------------|
| | | | kg-m | (ft-lb) | kg-m | (ft-lb) |
| 4T | 6 | 1 | 0.47 | (3.4) | 0.4 to 0.7 | (2.9 to 5.0) |
| | 8 | 1.25 | 1.11 | (8.0) | 1.0 to 1.6 | (7.3 to 11.6) |
| | 10 | 1.25 | 2.25 | (16.3) | 1.9 to 3.1 | (13.7 to 22.4) |
| | 10 | 1.5 | 2.14 | (15.5) | 1.8 to 3.0 | (13.0 to 21.7) |
| | 12 | 1.25 (ISO) | 4.40 | (31.8) | 3.5 to 5.5 | (25.3 to 39.8) |
| | 12 | 1.5 | 3.89 | (28.1) | 3.5 to 5.5 | (25.3 to 39.8) |
| | 12 | 1.75 | 3.74 | (27.0) | 3.0 to 5.0 | (21.7 to 36.2) |
| | 13 | 1.5 | 5.08 | (36.8) | 4.5 to 7.0 | (32.5 to 50.6) |
| | 14 | 1.5 | 6.33 | (45.8) | 5.0 to 8.0 | (36.2 to 57.8) |
| | 14 | 2 | 5.93 | (42.8) | 4.7 to 7.7 | (34.0 to 55.7) |
| | 16 | 1.5 | 9.57 | (69.2) | 7.5 to 11.0 | (54.2 to 79.6) |
| | 16 | 2 | 9.10 | (65.8) | 7.1 to 10.6 | (51.3 to 76.7) |
| 5T | 6 | 1 | 0.71 | (5.1) | 0.6 to 0.9 | (4.4 to 6.5) |
| | 8 | 1.25 | 1.66 | (12.0) | 1.5 to 2.2 | (10.9 to 15.9) |
| | 10 | 1.25 | 3.34 | (24.1) | 3.0 to 4.5 | (21.7 to 32.5) |
| | 10 | 1.5 | 3.22 | (23.3) | 2.7 to 4.2 | (19.5 to 30.4) |
| | 12 | 1.25 (ISO) | 6.60 | (47.7) | 5.0 to 8.0 | (36.2 to 57.8) |
| | 12 | 1.5 | 5.84 | (42.2) | 5.0 to 7.0 | (36.2 to 50.6) |
| | 12 | 1.75 | 5.61 | (40.6) | 4.8 to 6.8 | (34.7 to 49.2) |
| | 13 | 1.5 | 7.63 | (55.2) | 6.5 to 9.0 | (47.0 to 65.1) |
| | 14 | 1.5 | 8.90 | (65.3) | 7.5 to 11.0 | (54.2 to 79.6) |
| | 14 | 2 | 9.50 | (68.7) | 7.0 to 10.5 | (50.6 to 75.9) |
| | 16 | 1.5 | 14.36 | (103.8) | 12.0 to 17.0 | (86.8 to 123.0) |
| | 16 | 2 | 13.58 | (98.1) | 11.5 to 16.5 | (83.2 to 119.2) |
| 7T | 6 | 1 | 0.95 | (6.9) | 0.8 to 1.2 | (5.8 to 8.6) |
| | 8 | 1.25 | 2.21 | (16.1) | 2.0 to 3.0 | (14.5 to 21.7) |
| | 10 | 1.25 | 4.49 | (32.5) | 4.0 to 5.5 | (28.9 to 39.8) |
| | 10 | 1.5 | 4.29 | (31.0) | 3.7 to 5.2 | (26.8 to 37.6) |
| | 12 | 1.25 | 8.80 | (63.5) | 7.5 to 10.5 | (54.1 to 75.8) |
| | 12 | 1.5 | 7.78 | (56.2) | 7.0 to 9.0 | (50.6 to 65.1) |
| | 12 | 1.75 | 7.48 | (54.1) | 6.0 to 8.5 | (43.3 to 61.4) |
| | 13 | 1.5 | 10.17 | (73.5) | 8.0 to 12.0 | (57.8 to 86.8) |
| | 14 | 1.5 | 12.67 | (91.6) | 10.0 to 15.0 | (72.3 to 108.5) |
| | 14 | 2 | 11.86 | (85.8) | 9.5 to 14.0 | (68.7 to 101.2) |
| | 16 | 1.5 | 19.15 | (138.5) | 15.0 to 23.0 | (108.5 to 166.2) |
| | 16 | 2 | 18.11 | (131.0) | 14.0 to 22.0 | (101.2 to 159.0) |

— Note —

The above specified tightening torque is applicable only for female threads cut into a steel material.

If the female threads are cut in other materials than steel, and also tightening surfaces are encountered to heat or vibrations, these specified tightening torques must be reconsidered.

MAIN PARTS TIGHTENING TORQUE

| Tightening Parts | Tightening Torque | kg-m (ft-lb) |
|------------------------|-------------------|--------------|
| Cylinder head bolt | 11.5-13.5 | (83- 98) |
| Manifold | 3.9-5.1 | (28- 37) |
| For Calif. only | 5.0-7.0 | (36.2-50.6) |
| Camshaft thrust plate | 1-1.6 | (7- 12) |
| Crankshaft pulley | 16-20 | (116-145) |
| Piston pin | 5.4-7 | (39- 51) |
| Connecting rod cap | 4.8-7.6 | (35- 55) |
| Crankshaft bearing cap | No. 1-No. 3 | (90-108) |
| No. 4 | 10.5-13 | (76- 94) |
| Flywheel | 8.1-8.5 | (59- 61) |

ENGINE SPECIFICATIONS

| | |
|-------------------|-----------------------------------|
| Engine model | 2F |
| Type | 6-cylinder, in-line, 4 cycle, OHV |
| Bore and stroke | 94 x 101.6 mm (3.70 x 4.00 in) |
| Displacement | 4230 cc (257.9 cu.in) |
| Compression ratio | 7.8 to 1 |
| Firing order | 1-5-3-6-2-4 |

SERVICE SPECIFICATIONS

| ENGINE TUNE-UP | | | | |
|-------------------------------------|--------------------------|---------------------------|---------|-----------|
| Drive belt tension at 10 kg (22 lb) | mm (in) | | | |
| Fan pulley – Alternator | | 13 – 15 (0.51 – 0.59) | | |
| Fan pulley – Air pump (USA) | | 7 – 10 (0.28 – 0.39) | | |
| Alternator belt (USA) | | 13 – 15 (0.51 – 0.59) | | |
| Battery specific gravity | | 1.25 – 1.27 | | |
| Coolant capacity | | Liter | US gal. | Imp. gal. |
| | FA | approx. 25.5 | 6.7 | 5.6 |
| | FJ 40 | approx. 16 | 4.2 | 3.5 |
| | FJ 55 | approx. 16.5 | 4.4 | 3.6 |
| Engine oil capacity | | Liter | US qt. | Imp. qt. |
| | Total | 8 | 8.5 | 7.0 |
| | Crankcase | 7 | 7.4 | 6.2 |
| Recommended spark plug | | (ND) | (NGK) | |
| | Conventional type | W14EP | B5ES | |
| | Resistive type | W14EPR | BR5ES | |
| | For USA | W14EX | BP5EZ | |
| Spark plug gap | mm (in) | 0.8 (0.031) | | |
| | | 1.0 (0.039) For USA | | |
| Dwell angle | | 38° – 44° | | |
| Distributor point gap | mm (in) | 0.45 (0.018) | | |
| Condenser capacity | μF | 0.22 (Except for USA) | | |
| Valve clearance (Hot) | mm (in) | | | |
| | Intake | 0.20 (0.008) | | |
| | Exhaust | 0.35 (0.014) | | |
| Ignition timing at idling | | 7° BTDC | | |
| Initial idle speed at T/M in N | rpm | 650 ± 50 | | |
| Manifold vacuum at idling | mmHg (inHg) | 420 (16.5) | | |
| Fast idle | rpm | 1800 | | |
| TP setting speed | rpm | 1200 | | |
| | For Calif. rpm | 1400 | | |
| Compression pressure at 200 rpm | kg/cm ² (psi) | | | |
| | STD | 10.5 (149.3) | | |
| | Limit | 8.0 (113.8) | | |

CYLINDER HEAD

| | | |
|-------------------------------------|---------|---------------|
| Head surface warpage limit | mm (in) | 0.15 (0.0059) |
| Valve seat contacting surface angle | | 45° |
| Valve seat contacting width | mm (in) | |
| | Intake | 1.4 (0.055) |
| | Exhaust | 1.7 (0.067) |

VALVE GUIDE BUSHING

| | | | |
|---------------------|-------------------------|---------------------------|--|
| | | mm (in) | |
| Length | Intake | 54 (2.13) | |
| | Exhaust | 59 (2.32) | |
| Inner diameter | Both intake and exhaust | 8.01–8.03 (0.3154–0.3161) | |
| Projection distance | | 17 (0.67) | |

VALVE

| | | | |
|----------------------------|---------|----------------------------|--|
| | | mm (in) | |
| Valve head diameter | Intake | 46 (1.81) | |
| | Exhaust | 37.5 (1.48) | |
| Valve face angle | | 45° | |
| Stem diameter | Intake | 7.97–7.985 (0.3138–0.3144) | |
| | Exhaust | 7.96–7.975 (0.3134–0.3140) | |
| Stem oil clearance | Intake | 0.03–0.06 (0.0012–0.0024) | |
| | Exhaust | 0.04–0.07 (0.0016–0.0028) | |
| Stem oil clearance limit | Intake | 0.10 (0.0039) | |
| | Exhaust | 0.12 (0.0047) | |
| Margin limit | Intake | 0.8 (0.031) | |
| | Exhaust | 1.0 (0.039) | |
| Valve tip correcting limit | | 0.5 (0.020) | |

VALVE SPRING

| | | |
|----------------------|---------|--------------|
| Free height | mm (in) | 51.5 (2.028) |
| Installed height | mm (in) | 43.0 (1.693) |
| Installed load | kg (lb) | 32.5 (71.6) |
| Installed load limit | kg (lb) | 27 (59.5) |
| Squareness limit | mm (in) | 2.0 (0.079) |

ROCKER ARM AND SHAFT

mm (in)

| | |
|------------------------|-------------------------------|
| Rocker shaft diameter | 18.479–18.495 (0.7275–0.7281) |
| Shaft to arm clearance | 0.01–0.04 (0.0004–0.0016) |

MANIFOLD

mm (in)

| | |
|--------------------------------|------------|
| Manifold surface warpage limit | 2.0 (0.08) |
|--------------------------------|------------|

TIMING GEAR

mm (in)

| | |
|----------------|---------------------------|
| Backlash | 0.05–0.13 (0.0020–0.0051) |
| Backlash limit | 0.2 (0.008) |

CAMSHAFT

mm (in)

| | |
|---------------------------------|-------------------------------|
| Thrust clearance | 0.09–0.15 (0.0035–0.0059) |
| Thrust clearance limit | 0.2 (0.008) |
| Journal oil clearance | 0.025–0.075 (0.0010–0.0030) |
| Camshaft runout limit | 0.15 (0.0059) |
| Camshaft journal diameter (STD) | |
| Front | 47.955–47.975 (1.8880–1.8888) |
| Second | 46.455–46.475 (1.8289–1.8297) |
| Third | 44.955–44.975 (1.7699–1.7707) |
| Rear | 43.455–43.475 (1.7108–1.7116) |
| Camshaft U/S bearings | 0.25/0.50 |
| Cam lobe height | |
| Intake | 38.36–38.46 (1.5102–1.5142) |
| Exhaust | 38.25–38.35 (1.5059–1.5098) |
| Cam lobe height limit | |
| Intake | 38.0 (1.496) |
| Exhaust | 37.9 (1.492) |

CYLINDER BLOCK

mm (in)

| | |
|------------------------------|-----------------------------|
| Cylinder bore diameter (STD) | 94.00–94.05 (3.7008–3.7027) |
| Cylinder bore wear limit | 0.2 (0.008) |
| Gasket surface warpage limit | 0.15 (0.0059) |

PISTON AND RING

| | | mm (in) |
|--------------------------------------|-------------|-----------------------------|
| Piston diameter | STD | 93.97–94.02 (3.6996–3.7016) |
| | O/S 0.50 | 94.46–94.51 (3.7189–3.7209) |
| | O/S 1.00 | 94.96–95.01 (3.7386–3.7405) |
| | O/S 1.50 | 95.46–95.51 (3.7583–3.7602) |
| Piston clearance | | 0.03–0.05 (0.0012–0.0020) |
| Piston ring end gap | Top | 0.20–0.56 (0.0079–0.0220) |
| | 2nd | 0.20–0.58 (0.0079–0.0228) |
| Piston ring to ring groove clearance | Oil for NPR | 0.20–0.88 (0.0079–0.0346) |
| | for RIKEN | 0.20–0.58 (0.0079–0.0228) |
| Piston pin to piston oil clearance | Top | 0.03–0.06 (0.0012–0.0024) |
| | 2nd | 0.02–0.06 (0.0008–0.0024) |

CONNECTING ROD AND BEARING

| | | mm (in) |
|---------------------------------------|--|---------------------------|
| Connecting rod thrust clearance | | 0.11–0.23 (0.0043–0.0091) |
| Connecting rod thrust clearance limit | | 0.3 (0.012) |
| Bearing (crank pin) oil clearance | | 0.02–0.06 (0.0008–0.0024) |
| U/S bearings | | 0.05 0.25 0.50 |

CRANKSHAFT AND BEARING

| | | mm (in) |
|-----------------------------------|--------|-------------------------------|
| Crankshaft thrust clearance | | 0.06–0.16 (0.0024–0.0063) |
| Crankshaft thrust clearance limit | | 0.3 (0.012) |
| Runout limit | | 0.1 (0.004) |
| Main journal oil clearance | | 0.020–0.044 (0.0008–0.0017) |
| Crank pin diameter (STD) | | 53.98–54.00 (2.1252–2.1260) |
| Main journal diameter (STD) | Front | 66.972–66.996 (2.6367–2.6376) |
| | Second | 68.472–68.496 (2.6957–2.6967) |
| | Third | 69.972–69.996 (2.7548–2.7557) |
| | Rear | 71.472–71.496 (2.8139–2.8148) |
| Main journal U/S bearings | | 0.05 0.25 0.50 |

OIL PUMP

mm (in)

| | | |
|---------------------------------|--------------------------|---------------------------|
| Gear backlash | | 0.05–0.07 (0.0020–0.0028) |
| Gear backlash limit | | 0.95 (0.0374) |
| Tip clearance | | 0.03–0.11 (0.0012–0.0043) |
| Tip clearance limit | | 0.2 (0.008) |
| Side clearance | | 0.03–0.09 (0.0012–0.0035) |
| Side clearance limit | | 0.15 (0.0059) |
| Cover wear limit | | 0.15 (0.0059) |
| Relief valve operating pressure | kg/cm ² (psi) | 3.5–4.5 (49.8–64) |

RADIATOR

kg/cm² (psi)

| | | |
|----------------------------------|--|------------|
| Cap valve opening pressure | | 0.9 (12.8) |
| Cap valve opening pressure limit | | 0.6 (8.5) |

FLUID COUPLING

| | | | |
|------------------------|--------------|------------|----------|
| Silicone oil viscosity | FJ40 For USA | cst | 1000 |
| Silicone oil capacity | FJ40 For USA | cst | 3000 |
| | | cc (cu.in) | 35 (2.1) |
| | | cc (cu.in) | 50 (3.1) |

THERMOSTAT

| | | |
|---------------------------|---------|----------|
| Valve opening temperature | | |
| Start to open at | °C (°F) | 82 (180) |
| Fully opens at | °C (°F) | 95 (203) |
| Valve opening travel | mm (in) | 8 (0.31) |

FUEL PUMP

| | | |
|---------------------------------------|--------------------------|---------------------------------------|
| Discharge pressure | kg/cm ² (psi) | 0.24–0.34 (3.4–4.8) |
| Suction vacuum | mmHg (inHg) | 450 (17.7) |
| Discharge capacity at engine 2000 rpm | | More than 2400 cc (146.5 cu. in)/min. |

CARBURETOR

| | | |
|--|---------|---------------------|
| Float raised position | mm (in) | 7.5 (0.295) |
| Float lowered position | mm (in) | 1.1 (0.043) |
| Throttle valve full open angle | | 90° |
| Seco-touch angle | | 57° |
| Kick up | | 28° from bore |
| | | 25° from bore |
| Fast idle | mm (in) | 1.3 (0.051) |
| Choke breaker | | 38° from bore |
| Throttle positioner | mm (in) | 0.8 (0.031) |
| Idle mixture adjusting screw initial setting (Reference only) | | Screw out 1½ turns. |
| Accelerating pump stroke | mm (in) | 9.5 (0.374) |

STARTER

| | | mm (in) |
|--|---------|--------------------------|
| Starter part number | | 28100-60041, 28100-60061 |
| No load characteristics | Ampere | Less than 50 |
| | RPM | More than 5000 |
| | Voltage | 11 |
| Armature shaft to bushing clearance | | 0.05 (0.0020) |
| Limit | | 0.2 (0.008) |
| Armature shaft thrust clearance | | 0.05–0.35 (0.002–0.0138) |
| Brush length | | 19 (0.75) |
| Brush length limit | | 13 (0.51) |
| Commutator runout | | Less than 0.05 (0.0020) |
| Commutator runout limit | | 0.4 (0.016) |
| Commutator diameter | | 32.7 (1.287) |
| Commutator diameter limit | | 31 (1.22) |
| Mica depth | | 0.5–0.8 (0.020–0.031) |
| Mica depth limit | | 0.2 (0.008) |
| Pinion end to stop collar clearance | | 0.2–4.0 (0.008–0.16) |
| Magnetic switch stud length (Reference only) | | 34 (1.34) |
| Armature shaft thrust adjusting shim thickness | | 0.5 (0.02) |

DISTRIBUTOR

mm (in)

| | |
|------------------------|------------------------|
| Shaft thrust clearance | 0.15-0.5 (0.006-0.020) |
| Point gap | 0.45 (0.018) |
| Dwell angle | 39° - 43° |
| Damping spring gap | 0.1-0.4 (0.004-0.016) |

Advance characteristics

| Part No. 19100-61010 | Vacuum mmHg (inHg) | Dis. advance angle Degree |
|-------------------------------------|--------------------|---------------------------|
| 19100-61030 Vacuum advance angle | 100 (3.94) | Advance begins |
| | 200 (7.87) | 5 |
| | 300 (11.8) | 8.5 |
| Governor advance angle | Distributor rpm | Dis. advance angle Degree |
| | 450 | Advance begins |
| | 900 | 9 |
| 1600 | 15 | |

| Part No. 19100-60090 | Vacuum mmHg (inHg) | Dis. advance angle Degree |
|------------------------|---------------------|---------------------------|
| Vacuum advance angle | 130-170 (5.12-6.69) | Advance begins |
| | 220 (8.66) | 3-5.6 |
| | 300 (11.8) | 7.5-9.5 |
| Governor advance angle | Distributor rpm | Dis. advance angle Degree |
| | 370-530 | Advance begins |
| | 900 | 8.2-9.8 |
| 1600 | 11-13 | |

| Part No. 19100-61020 | Vacuum mmHg (inHg) | Dis. retard angle Degree |
|------------------------|--------------------|---------------------------|
| Vacuum retard angle | 80 (3.15) | Retard begins |
| | 120 (4.72) | 4.0 |
| Governor advance angle | Distributor rpm | Dis. advance angle Degree |
| | 490 | Advance begins |
| | 900 | 7.0 |
| 1800 | 15.0 | |

| | | | | |
|------------------------|-------------|-------------|--------------------|--------|
| Part No. 19100-61021 | Vacuum | mmHg (inHg) | Dis. retard angle | Degree |
| | | 100 (3.94) | Retard begins | |
| Vacuum retard angle | | 160 (6.30) | 5 | |
| | Distributor | rpm | Dis. advance angle | Degree |
| Governor advance angle | | 600 | Advance begins | |
| | | 900 | 6.5 | |
| | | 1900 | 10 | |

| | | | | |
|------------------------|-------------|-------------|--------------------|--------|
| Part No. 19100-61060 | Vacuum | mmHg (inHg) | Dis. advance angle | Degree |
| | | 100 (3.94) | Advance begins | |
| Vacuum advance angle | | 160 (6.30) | 5 | |
| | Distributor | rpm | Dis. advance angle | Degree |
| Governor advance angle | | 500 | Advance begins | |
| | | 1600 | 10 | |
| Vacuum retard angle | Vacuum | mmHg (inHg) | Dis. advance angle | Degree |
| | | 80 (3.15) | Advance begins | |
| | | 140 (5.51) | 5 | |

IGNITION COIL (Reference only)

| | | |
|--------------------------------|-------------------|--------------|
| Primary coil resistance | W/O resistor type | 2.6 – 4.0 Ω |
| | W/ resistor type | 1.3 – 1.6 Ω |
| Secondary coil resistance | W/O resistor type | 6.9 – 9.0 Ω |
| | W/ resistor type | 9.5 – 14.5 Ω |
| External resistor resistance | | 1.3 – 1.7 Ω |
| Insulation resistance at 500 V | | Over 10 MΩ |

HIGH TENSION CORD

| | | |
|-----------------------|--|-----------------|
| End to end resistance | | Less than 25 kΩ |
|-----------------------|--|-----------------|

SPARK PLUG

| | | |
|------------------------|-------------------|---------------------------|
| Spark plug gap | mm (in) | 0.8 (0.031) |
| Recommended spark plug | | 1.0 (0.039) . . . For USA |
| | | (ND) (NGK) |
| | Conventional type | W14EP B5ES |
| | For USA | W14EX BP5EZ |
| | Resistive type | W14EPR BR5ES |

ALTERNATOR

| Part number | Conventional Type | | | W/Vacuum pump | Heavy Duty Type | | |
|----------------------|-------------------|-------------------|-------|---------------|-----------------|-------------------|----|
| | 27020-60010 | 60020 | 60071 | 60080 | 60030 | 60040 | |
| Maximum output | Ampere | 40 | 50 | 40 | 40 | 50 | 55 |
| Brush exposed length | | 12.5 mm (0.49 in) | | | | | |
| Limit | | 5.5 mm (0.22 in) | | | | | |
| Brush length | | | | | | 18.5 mm (0.73 in) | |
| Limit | | | | | | 8.0 mm (0.31 in) | |

ALTERNATOR REGULATOR (Reference only)

| Part number | 27700-36010 | 27700-60080 |
|-----------------------------------|---------------|-------------|
| Regulating voltage | 13.8 – 14.8 V | ← |
| Relay operating voltage | 4.0 – 5.8 V | – |
| Voltage relay coil resistance | 25 Ω | – |
| Voltage regulator coil resistance | approx. 100Ω | ← |
| Regulator resistor resistance | approx. 11Ω | ← |

MEMO

MEMO

MEMO

MEMO

MEMO

MEMO

MEMO

MEMO

MEMO

MEMO

MEMO

MEMO

MEMO

MEMO

MEMO

MEMO

TOYOTA
QUALITY SERVICE

OVERSEAS SERVICE DIVISION
TOYOTA MOTOR CORPORATION

PRINTED IN JAPAN ©
First Printing: Dec. 30, 1974 01-741230-00-1
21st Printing: Apr. 11, 1991 21-913411-00-2