

TOYOTA

B SERIES ENGINE

REPAIR MANUAL

Aug., 1980

**INCLUDES
B, 2B & 3B**

 **TOYOTA MOTOR SALES CO., LTD**

Pub. No. 36047

FOREWORD

This repair manual has been prepared to provide information covering general service repair for the B, 2B and 3B engines equipped on the TOYOTA DYNA, COASTER and LAND CRUISER.

*Applicable models: BU 20, 30 series
BB 10 series
BJ 40, 42, 43, 45, 46, 60 series*

For instructions on how to use this manual, please refer to page 1-4. Specifications contained herein are based on the August, 1980 production model. For specifications on other models, please refer to the respective Service Specification Manual.

TOYOTA MOTOR SALES CO.,LTD.

SECTION INDEX

NAME	SECTION
INTRODUCTION	1
ENGINE TUNE-UP	2
ENGINE SERVICE	3
LUBRICATION SYSTEM	4
COOLING SYSTEM	5
FUEL SYSTEM	6
EDIC SYSTEM	7
STARTING SYSTEM	8
CHARGING SYSTEM	9
SST & SERVICE SPECIFICATIONS	10

INTRODUCTION

	Page
GENERAL REPAIR INSTRUCTIONS	1-2
ABBREVIATIONS USED IN TOYOTA REPAIR MANUALS	1-3
HOW TO USE THIS MANUAL	1-4
SYMBOLS	1-6
FRONT CAB TILT PROCEDURE (FOR DYNA SERIES)	1-7

GENERAL REPAIR INSTRUCTIONS

1. Use fender, seat and floor covers to keep the car clean and prevent damage.
2. During disassembly, keep parts in order to facilitate reassembly.
3. Before performing electrical work, disconnect the cable from the battery terminal.
4. Always replace cotter pins, gaskets and O rings with new ones.
5. When necessary, use a sealer on gaskets to prevent leaks.
6. Carefully observe all specifications for bolt tightening torques. Always use a torque wrench.
7. Use genuine Toyota parts.
8. When replacing fuses, be sure the new fuse is the correct amperage rating. DO NOT exceed the fuse amp rating or use one of a lower rating.
9. If the vehicle is to be jacked up only at the front or rear end, be sure to block the wheels in order to ensure safety.
10. After the vehicle is jacked up, be sure to support it on stands. It is extremely dangerous to do any work on the vehicle raised on a jack alone, even for a small job that can be finished quickly.
11. Use of a special service tool (SST) may be required, depending on the nature of the repair. Be sure to use SST where specified and follow the proper work procedure. A list of SST can be found at the back of this manual.

ABBREVIATIONS USED IN TOYOTA REPAIR MANUALS

For convenience, the following abbreviations are used in Toyota repair manuals.

Abbreviation	Term	Abbreviation	Term
A/T	Automatic Transmission	OPT	Option
BDC	Bottom Dead Center	O/S	Oversize
BTDC	Before Top Dead Center	RH	Right-hand
DHAC	Diesel High Altitude Compensator	RHD	Right-hand Drive
EDIC	Electrical Diesel Injection Control	SST	Special Service Tool
EX	Exhaust	STD	Standard
IN	Intake	T	Tightening Torque
LH	Left-hand	TDC	Top Dead Center
LHD	Left-hand Drive	U/S	Undersize
MP	Multipurpose	W/	With
M/T	Manual Transmission	W/O	Without

HOW TO USE THIS MANUAL

1. OVERVIEW ILLUSTRATION

Many service operations begin with an overview illustration as a general guide.

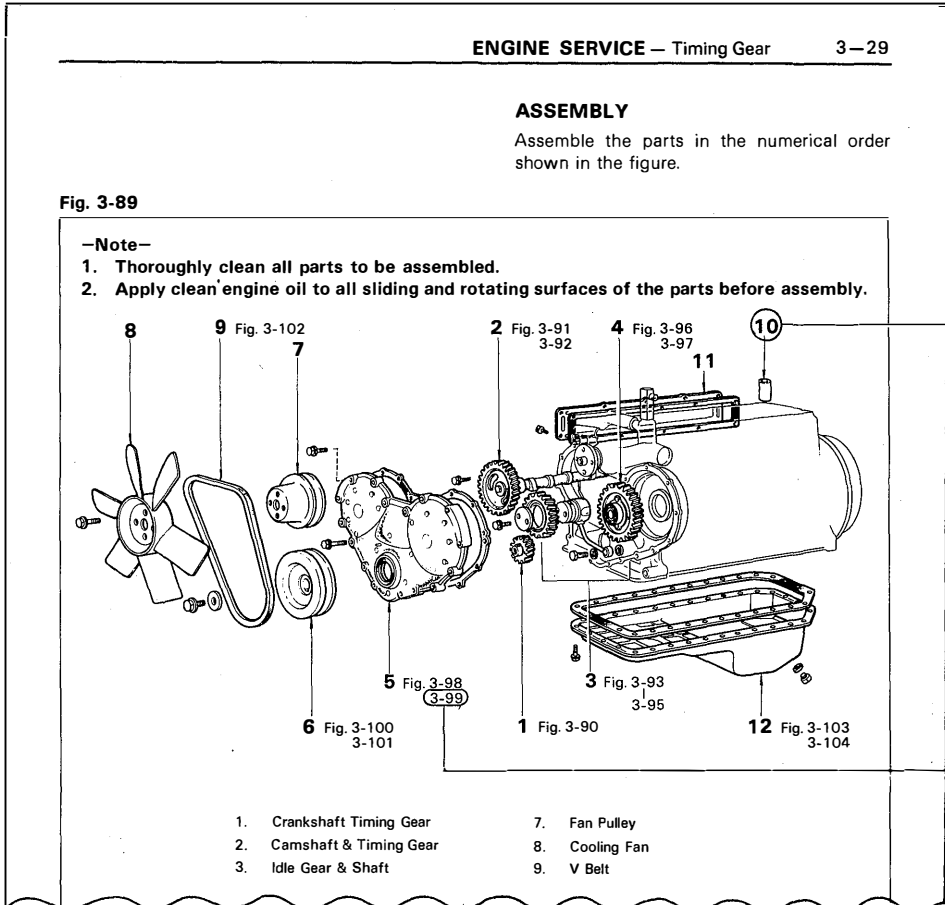

A : The bold numbers indicate the order in which the work is to be done.

B : The figure numbers refer you to more detailed instructions and specifications.

2. ILLUSTRATED INSTRUCTIONS

All important steps in every service job are illustrated. Obvious steps are omitted to save space. Experienced technicians may only need to glance at the overview illustration and/ or specifications.

3-32 **ENGINE SERVICE — Timing Gear**

Fig. 3-99

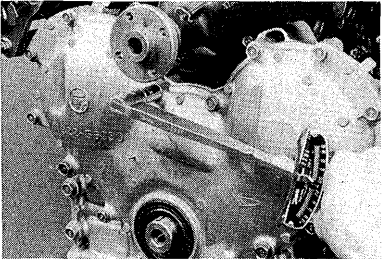

Tighten the timing gear cover.
Tightening torque:
8 mm bolt 1.5 - 2.2 kg-m
(11 - 15 ft-lb)
10 mm bolt 3.0 - 4.5 kg-m
(22 - 32 ft-lb)

Fig. 3-100

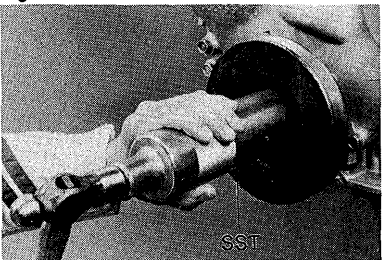

Drive in the crankshaft pulley with SST.
SST [09316-60010]

Fig. 3-101



Tighten the retaining bolt.
Tightening torque: 20.0 - 24.0 kg-m
(145 - 173 ft-lb)

- (C)** : The pictures give basic information on what to do in each step.
- (D)** : A symbol is often used to explain the action required.
- (E)** : The text explains how to perform the step.
- (F)** : Specifications, Notes and Cautions are given in bold type so you won't miss them.

SYMBOLS

The following symbols have been adopted for simplicity and for easy comprehension.



REMOVE or DISASSEMBLE



INSTALL or ASSEMBLE



INSPECT



MEASURE



TIGHTEN



CLEAN



IMPORTANT

FRONT CAB TILT PROCEDURE (FOR DYNA SERIES)

Fig. 1-1

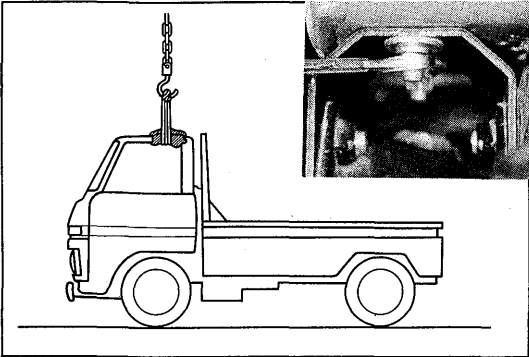

When it is necessary to tilt the cab to perform major maintenance procedures, either of the following two methods may be used.

—Note—
Insure working safety at all times.

HOIST METHOD

1. Remove the cab mounting bolts.
2. Install the hoist to the cab.
3. Insuring that the hoist is kept perpendicular, tilt the cab by slowly pushing the vehicle backwards.

—Note—
Be careful not to damage any wiring or hoses.

Fig. 1-2

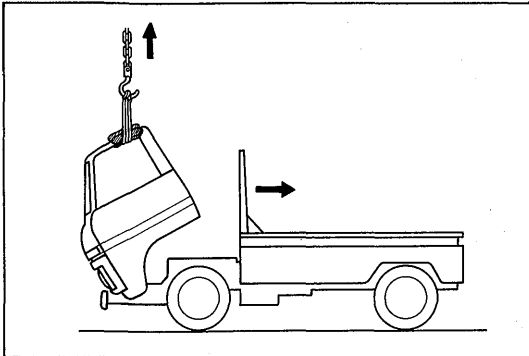
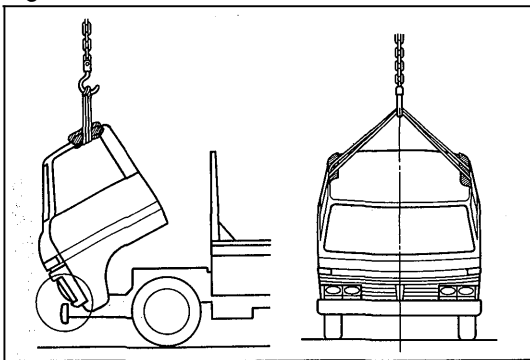

Fig. 1-3



4. Insure that there is no interference between the front grill and bumper.

—Note—
Always keep the cab supported by the hoist during work.

Fig. 1-4

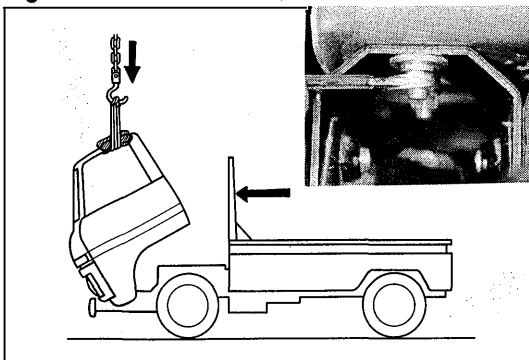

5. To lower the cab, slowly push the vehicle forward.
6. Install the mounting bolts after the cab has fully returned to its original position.

Fig. 1-5

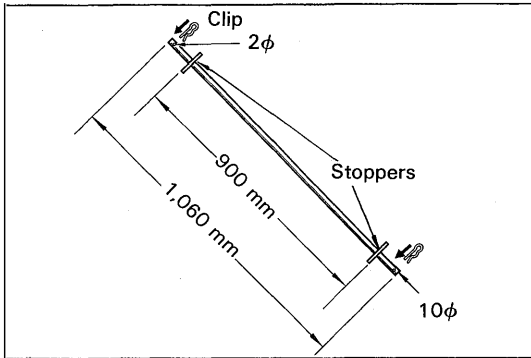

Fig. 1-6

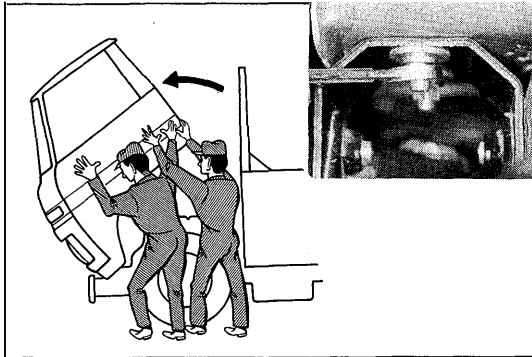

Fig. 1-7

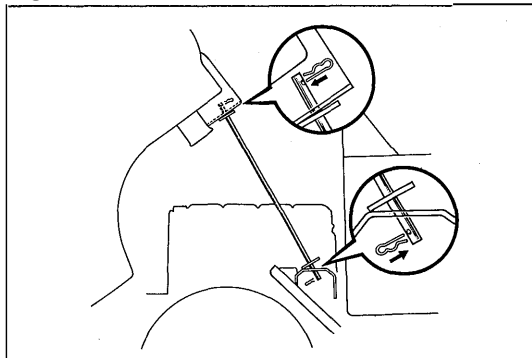
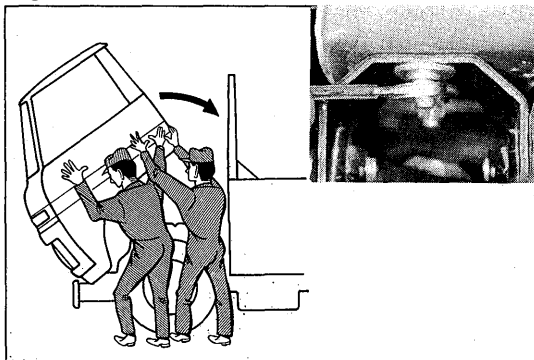

Fig. 1-8

**LOCKING STAY METHOD**

1. In advance, prepare a locking stay as shown in the figure.
 - Thickness 10 mm (0.39 in.)
 - Length 1,060 mm (41.73 in.)
 - Clip (clutch release bearing clip) part no. 31232-30010
 - Weld two stoppers positioned 900 mm (35.43 in.) apart.
 - Drill a 2 mm hole at each end.

2. Remove the cab mounting bolts.
3. With 2 persons on both the left and right side, lift the upward.

—Note—

Be careful not to damage any wiring or hoses.

4. Insuring that there is no interference between the front bumper and grill, install the locking stay in the mounting bolt holes.

—Note—

Be careful that the cab does not overturn.

5. After necessary work is completed, the cab should be lowered slowly by four persons.
6. Install the mounting bolts after the cab has been fully lowered to its original position.

ENGINE TUNE-UP

	Page
ENGINE TUNE-UP ITEMS	2-2
COOLING SYSTEM	2-4
DRIVE BELT	2-5
AIR CLEANER	2-6
BATTERY	2-7
OIL FILTER	2-8
ENGINE OIL	2-9
FUEL FILTER	2-9
INJECTION PUMP	2-11
COMPRESSION PRESSURE	2-11
INJECTION NOZZLE	2-13
INJECTION TIMING	2-15
VALVE CLEARANCE	2-17
IDLE SPEED & MAXIMUM SPEED	2-18

ENGINE TUNE-UP ITEMS

ITEM		REMARKS
1	COOLING SYSTEM Coolant level Coolant quality Leakage Radiator cap valve opening pressure STD Limit Coolant capacity (w/ Heater) BJ40, 42, 43, 45 & 46 Series BJ60 Series BU20, 30 Series BB10 Series	Full line 0.75 – 1.05 kg/cm ² (10.7 – 14.9 psi) 0.6 kg/cm ² 8.5 psi 12.5 liters 13.2 US qt 11.0 Imp.qt 13.3 liters 14.1 US qt 11.7 Imp.qt 13.1 liters 13.8 US qt 11.5 Imp.qt 14.5 liters 15.3 US qt 12.8 Imp.qt
2	DRIVE BELT (For General) Deflection at 10kg (22lb) force w/o Air con. New belt Used belt w/ Air con. (BB10) New belt Used belt (For Canada) Borroughs belt tension gauge No. BT-33-73F New belt Used belt	8 – 12 mm 0.31 – 0.47 in. 11 – 14 mm 0.43 – 0.55 in. 10 – 13 mm 0.39 – 0.51 in. 12 – 15 mm 0.47 – 0.59 in. 120 – 170 lb 80 – 120 lb
3	AIR CLEANER Clean element Oil capacity (Oil bath type)	Indicated level
4	BATTERY Specific gravity Electrolyte level	1.25 – 1.27 at 20°C (68°F)
5	OIL FILTER Replacement Cartridge type Paper element type	SST [09228-44010]
6	ENGINE OIL Oil level Oil quality Replenishment Oil capacity Dry fill Drain & refill w/ Oil filter w/o Oil filter	F line API service CC-CD classification 7.3 liters 7.7 US qt 6.4 Imp.qt 6.7 liters 7.1 US qt 5.9 Imp.qt 5.8 liters 6.1 US qt 5.1 Imp.qt

ITEM		REMARKS
7	FUEL FILTER Replacement Cartridge type Element type Air bleeding	SST [09228-34010]
8	INJECTION PUMP Lubricate diaphragm housing	3 or 4 drops of diaphragm oil
9	COMPRESSION PRESSURE at 250 rpm STD Limit Difference between each cylinder	30.0 kg/cm ² 427 psi 20.0 kg/cm ² 284 psi Less than 2.0 kg/cm ² (28 psi)
10	INJECTION NOZZLE Opening pressure New nozzle Reused nozzle Spray condition Leakage test Cleaning	115 – 125 kg/cm ² (1,636 – 1,778 psi) 105 – 125 kg/cm ² (1,493 – 1,778 psi) 4° conical form at 90 kg/cm ² 1,280 psi
11	INJECTION TIMING Stationary Air bleeding Fuel filter Injection pump High pressure pipe	14° BTDC
12	VALVE CLEARANCE Hot Intake Exhaust	0.20 mm 0.008 in. 0.36 mm 0.014 in.
13	IDLE SPEED	650 rpm
14	MAXIMUM SPEED No-load	4,050-4,100 rpm
15	PREHEATING SYSTEM Glow time at 0°C (32°F) Load current per one glow plug BJ60 12V type 24V type others 12V type 24V type Glow plug resistance BJ60 12V type 24V type others 12V type 24V type	About 15 seconds 7.2 – 9.8 A 3.8 – 5.2 A 7.6 – 10.4 A 4.1 – 5.5 A 1.2 Ω 5.1 Ω 0.9 Ω 4.3 Ω

Fig. 2-1

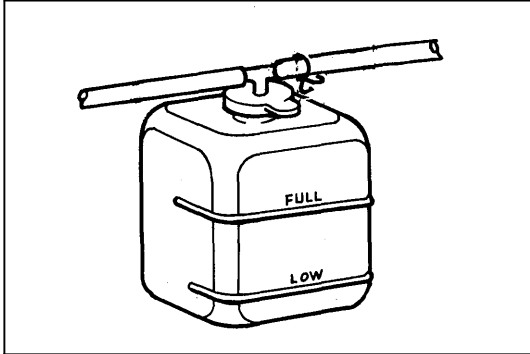

COOLING SYSTEM

CHECK COOLANT LEVEL

If low, fill reservoir to FULL line.

—Note—

To maintain freeze protection, use a recommended anti-freeze.

Fig. 2-2

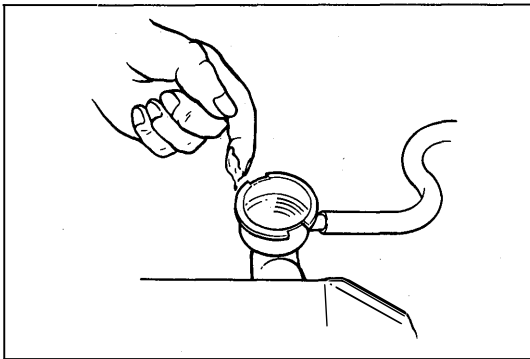

CHECK COOLANT QUALITY

Check for:

1. Coolant cleanliness.
2. Rust or scale deposits around the radiator cap and filler neck.
3. Entry of oil.

Fig. 2-3

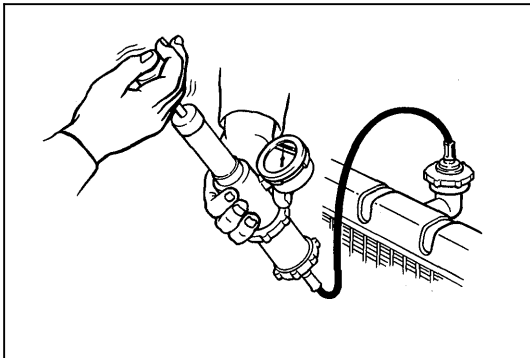

CHECK COOLING SYSTEM PARTS

Check for:

1. Damaged or deteriorated radiator and water hoses.
2. Loose hose clamps.
3. Damaged or corroded radiator core.
4. Leakage from the water pump, radiator core or loose water drain cock.

Fig. 2-4

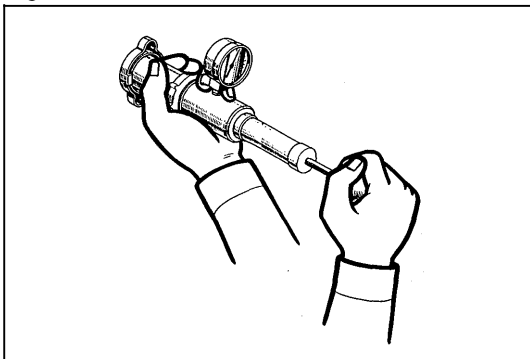

5. Faulty operation of radiator cap. Inspect the spring tension and seating condition of the radiator cap vacuum valves. If the valve opens at a pressure below specification or is otherwise defective, replace the radiator cap.

Valve opening pressure:

STD 0.75 – 1.05 kg/cm²
(10.7 – 14.9 psi)

Limit 0.6 kg/cm²
(8.5 psi)

Fig. 2-5

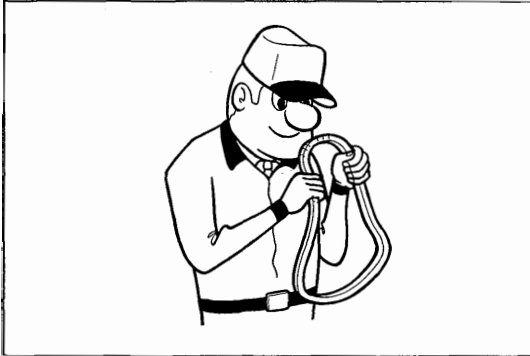

DRIVE BELT

VISUAL CHECK

Check for:

1. Cracks, deterioration, stretching or wear.
2. Adherence of oil or grease.

Fig. 2-6

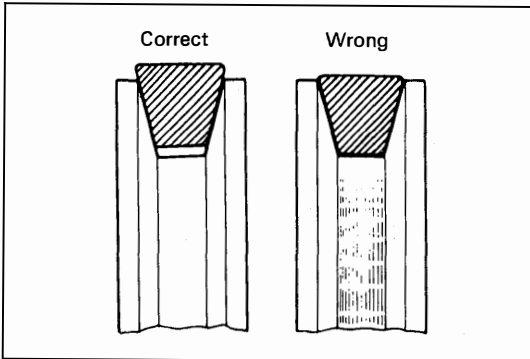

3. Improper belt-to-pulley contact.

Fig. 2-7

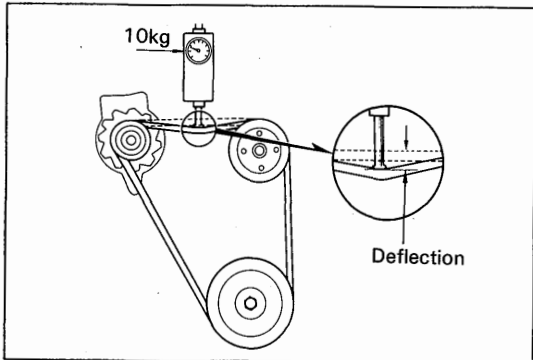

CHECK BELT TENSION

For General Destination

Press on the belt at the point indicated in the figure with 10 kg (22 lb) of force. The belt should deflect the amount specified.

Drive belt tension:

w/o Air con.

New belt 8 – 12 mm
(0.31 – 0.47 in.)

Used belt 11 – 14 mm
(0.43 – 0.55 in.)

w/ Air con. (BB10)

New belt 10 – 13 mm
(0.39 – 0.51 in.)

Used belt 12 – 15 mm
(0.47 – 0.59 in.)

Fig. 2-8

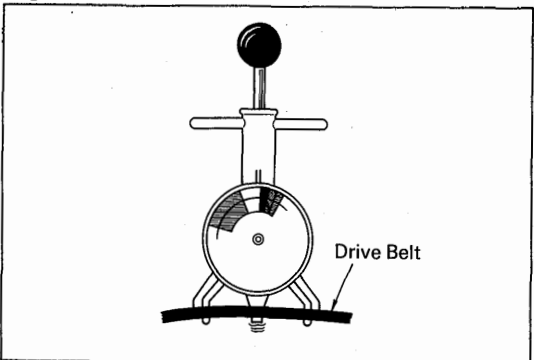

For Canada:

Using a time borroughs tension gauge, BT-33-73F, adjust the following value.

Drive belt tension:

New belt 120 – 170 lb

Used belt 80 – 120 lb

Fig. 2-9

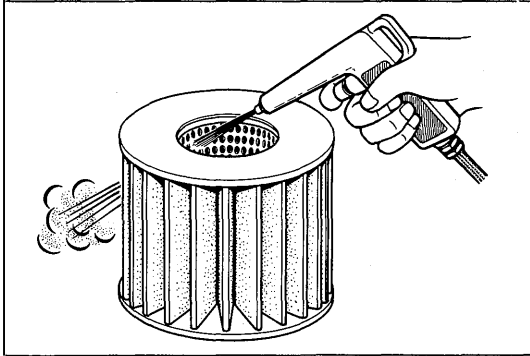

AIR CLEANER

[Paper Element & Cyclone Type]

CLEAN ELEMENT

1. Remove the air cleaner.
2. Remove the element and blow compressed air from inside
3. Replace the element with a new one if torn or excessively dirty.

Fig. 2-10

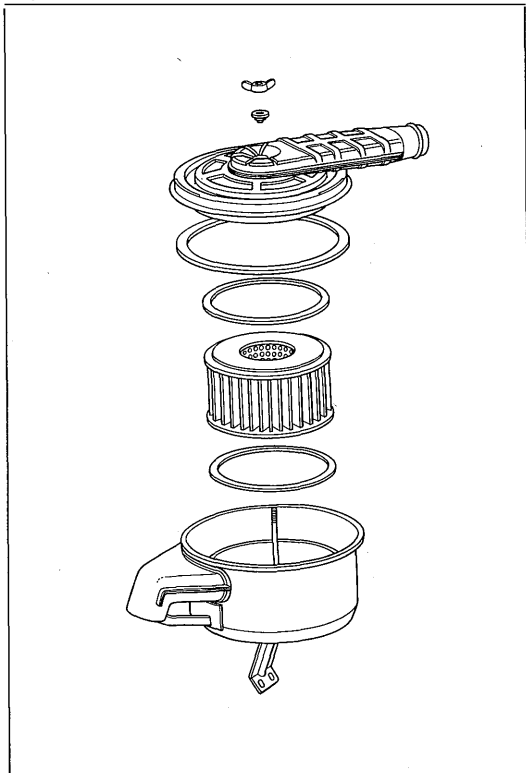

VISUAL CHECK

Check for:

1. Damaged, worn or deteriorated gaskets.
2. Damaged or worn seal washer.



INSTALL AIR CLEANER

1. Install the gaskets.
2. Finger tighten the stay.
3. After installing the element, set the air cleaner cap.
4. Tighten the wing nut and stay.
5. Connect the hoses to air cleaner.

Fig. 2-11

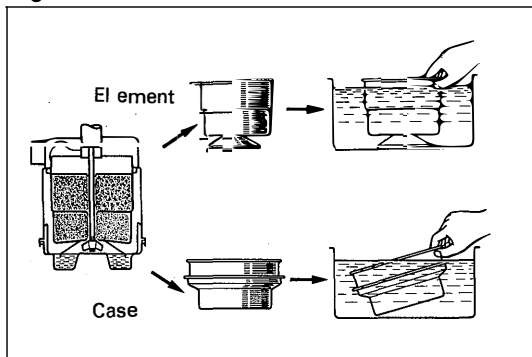

[Oil Bath Type]

CLEAN ELEMENT

1. Remove the air cleaner and element.
2. Wash the element and case with kerosene and dry them thoroughly.

Fig. 2-12

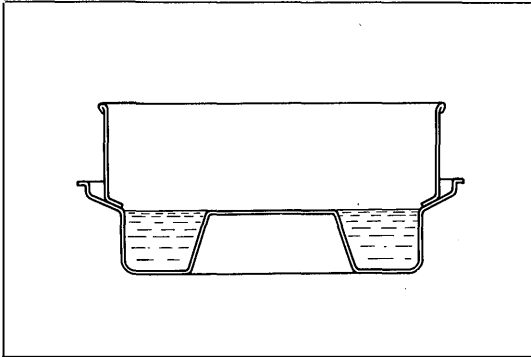

INSTALL AIR CLEANER



1. Refill the cap up to the indicated level with clean engine oil.
2. Saturate the element with clean engine oil.
3. Install the cap and element.
4. Tighten the air cleaner on the air cleaner support and connect the hoses to air cleaner.

Fig. 2-13

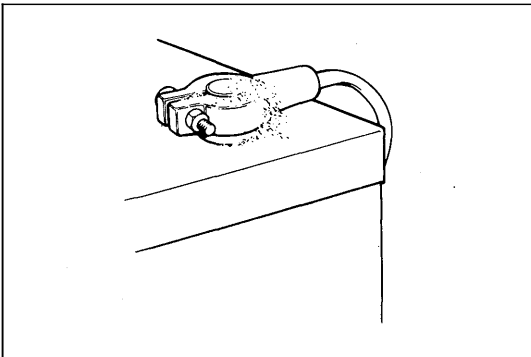

**BATTERY
VISUAL CHECK**



Check for:

1. Rusted battery support.
2. Loose terminal connections.
3. Rusted or deteriorated terminals.
4. Damaged or leaking battery.

Fig. 2-14

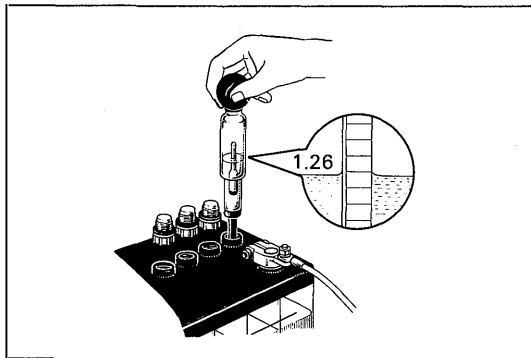

MEASURE SPECIFIC GRAVITY



Check the specific gravity of electrolyte with a hydrometer.

Specific gravity:

1.25 – 1.27 at 20°C

(68°F)

Fig. 2-15

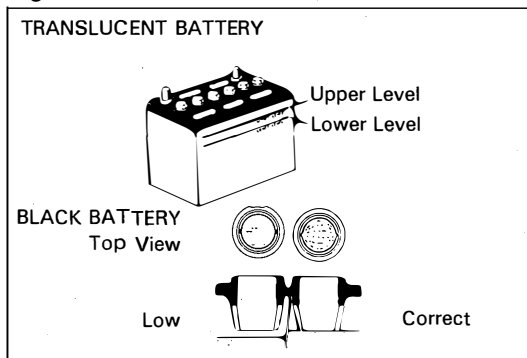

CHECK ELECTROLYTE LEVEL



Check the electrolyte quantity.
Refill with distilled water, if insufficient.

Fig. 2-16

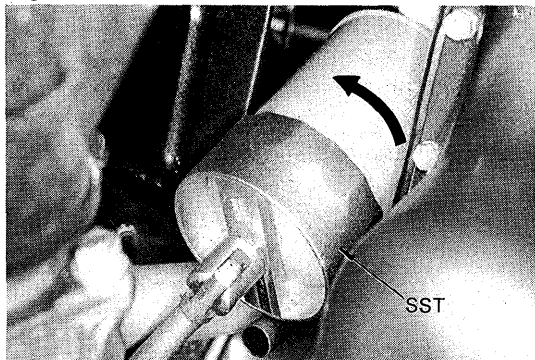

Fig. 2-17

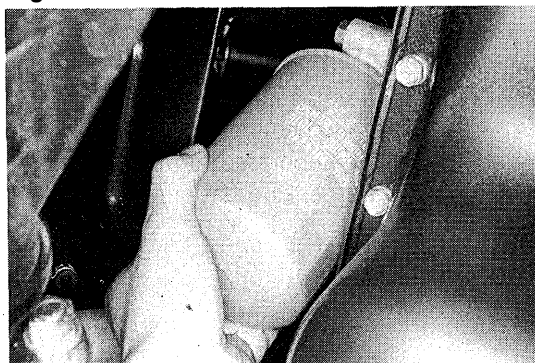
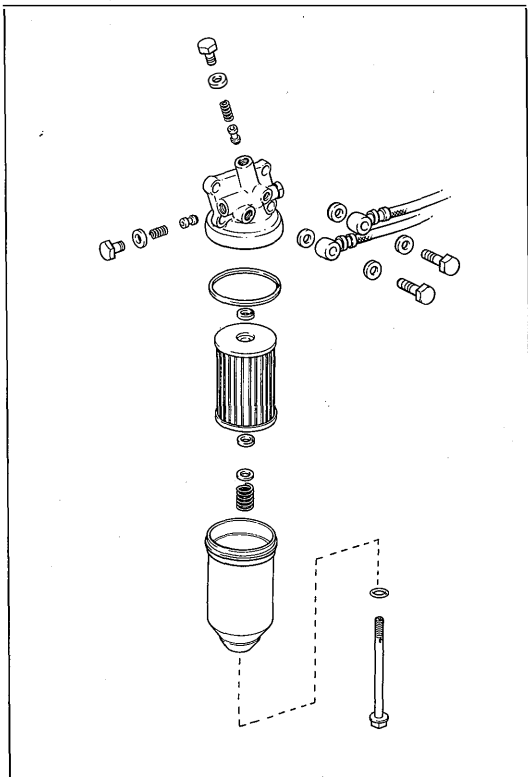

Fig. 2-18



OIL FILTER

REPLACEMENT

[Cartridge Type]

1. Remove the oil filter with SST.



2. Install a new filter and tighten it firmly by hand.



—Note—

Do not tighten the filter with SST or a wrench.

3. Start the engine and check for oil leakage.
4. Stop the engine and recheck the oil level.

[Paper Element Type]

Refer to LUBRICATION SYSTEM section.



—Note—



1. Use new gaskets. Assemble the filter body gasket with the rounded end facing upward (toward cap).
2. After starting the engine, check for oil leaks and recheck the oil level.

Fig. 2-19

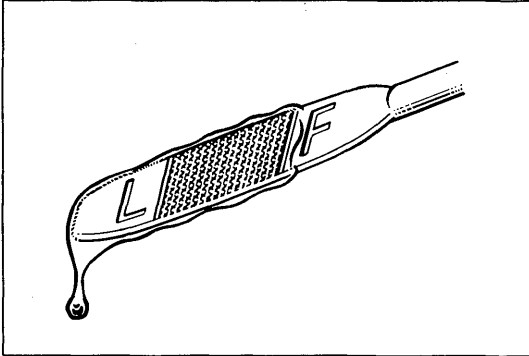

Fig. 2-20

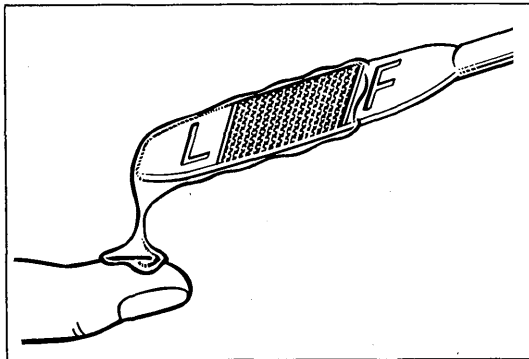

Fig. 2-21

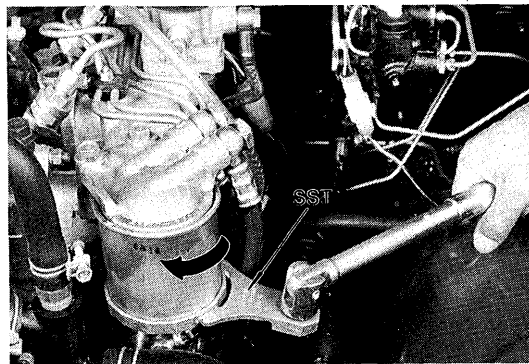
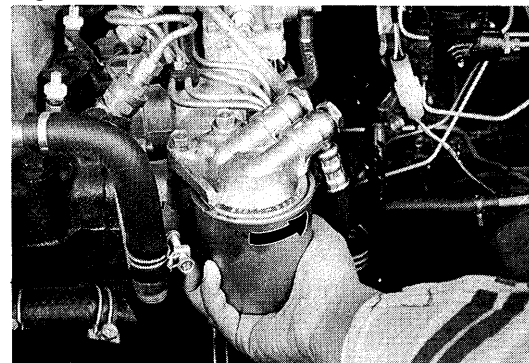

Fig. 2-22



ENGINE OIL



CHECK OIL LEVEL

The oil level should be between the L and F lines. If low, check for leakage and add oil up to the F mark.

—Note—

Use API service CC-CD classification engine oil.



CHECK OIL QUALITY

Check for:

1. Deterioration.
2. Entry of water.
3. Discoloration or thinning.



FUEL FILTER

REPLACE FUEL FILTER

[Cartridge Type]

1. Remove the fuel filter with SST.
SST [09228-34010]



2. Install a new filter and tighten it by hand.

—Note—

1. After bleeding the air, tighten the filter firmly by hand.
2. Be careful that fuel does not splash onto the radiator hose.

Fig. 2-23

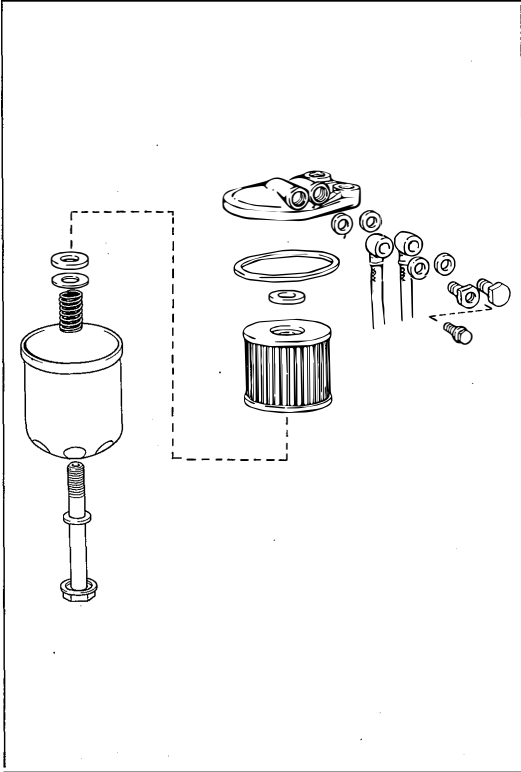
**[Element Type]**

Refer to FUEL SYSTEM section.

—Note—

1. Use new gaskets.
2. Do not damage the element by over-tightening the filter case set bolt.

Fig. 2-24

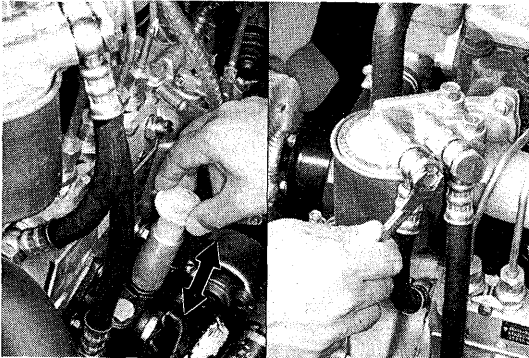
**BLEED AIR
[for Both Types]**

1. Bleed the air from fuel filter by operating the priming pump.
2. After starting the engine, check for oil leaks.

Fig. 2-25

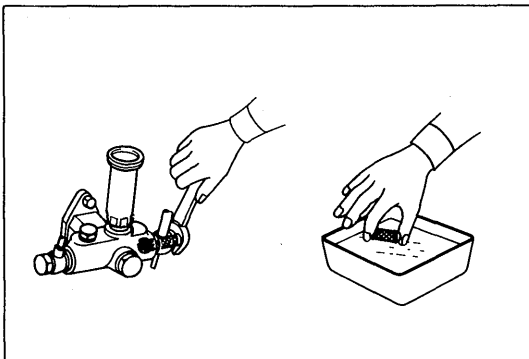
**[Feed Pump Filter]**

Remove the inlet union and clean the filter.

Fig. 2-26

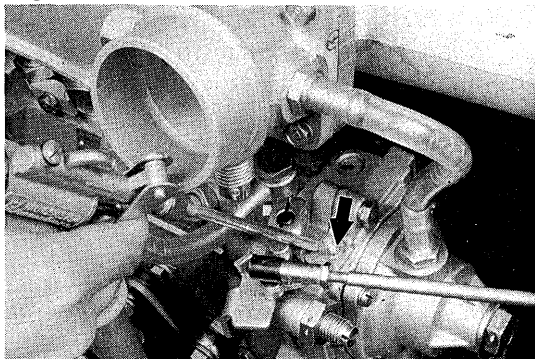

Fig. 2-27

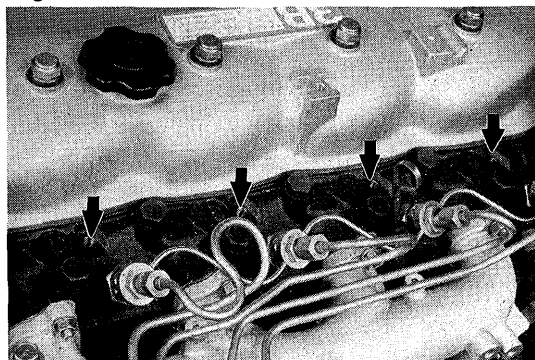

Fig. 2-28

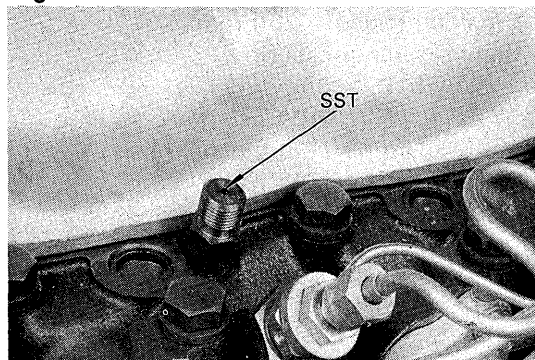
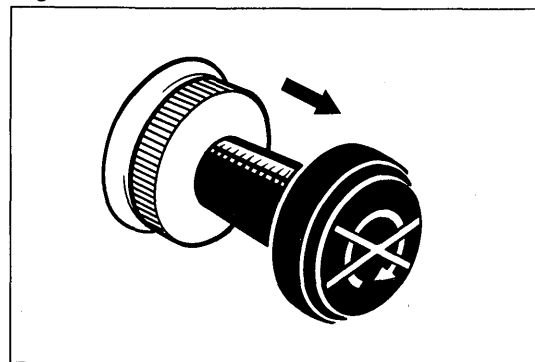

Fig. 2-29



INJECTION PUMP

LUBRICATE DIAPHRAGM HOUSING

Place 3 or 4 drops of diaphragm oil to the diaphragm.

—Note—

Before lubricating the diaphragm, make sure that there is no fuel nor engine oil in the governor chamber. If necessary, drain the fuel or engine oil by loosening the drain bolt.

COMPRESSION PRESSURE



1. Warm-up the engine.
2. Remove all glow plugs.

—Note—

Make sure that the lead wire is not grounded.

3. Install SST to the glow plug mounting hole and insert a compression gauge. SST [09992-00021]

[Without EDIC System]

4. Pull the stop button all the way out.

Fig. 2-30

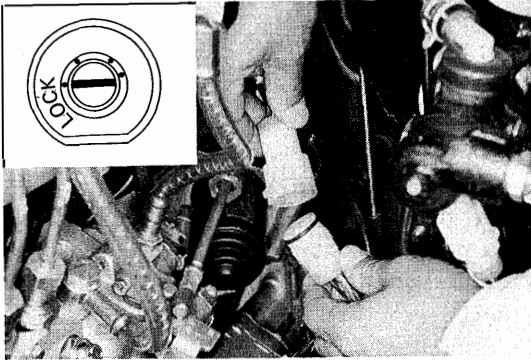
**[With EDIC System]**

4. Turn the starter switch to LOCK position and then disconnect the EDIC motor wire connector.

Fig. 2-31

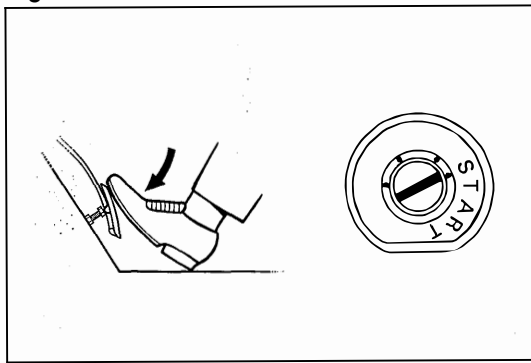

5. Depress the accelerator pedal all the way down.
6. Measure the compression pressure while cranking the engine with the starter motor.

—Note—

Keep pressure measuring time to a minimum.

Fig. 2-32

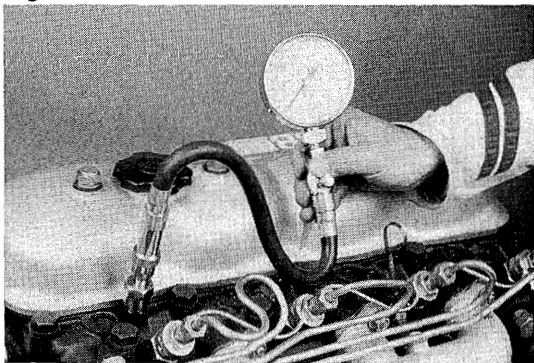

Cranking speed: 250 rpm

Compression pressure:

**STD 30.0 kg/cm²
(427 psi)**

**Limit 20.0 kg/cm²
(284 psi)**

Difference between each cylinder:

**Less than 2.0 kg/cm²
(28 psi)**

Fig. 2-33

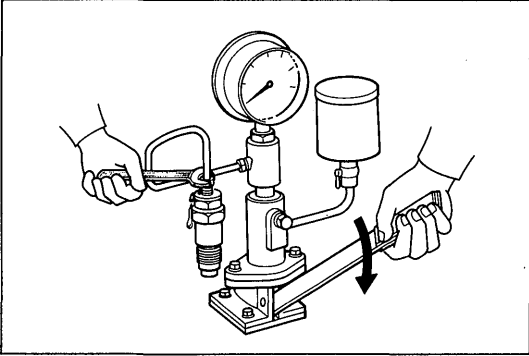

Fig. 2-34

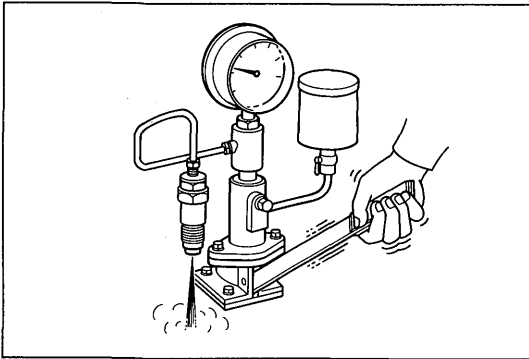

Fig. 2-35

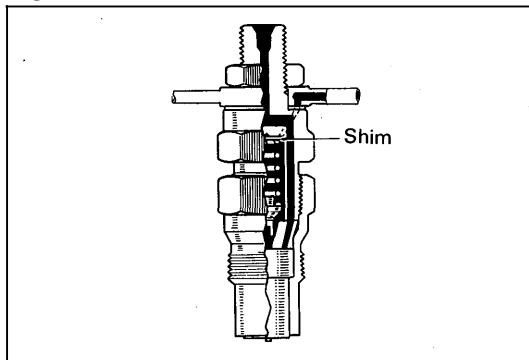
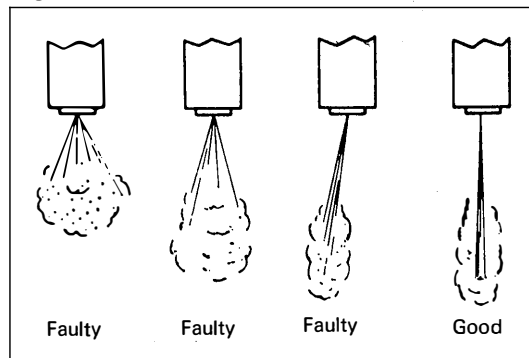

Fig. 2-36



INJECTION NOZZLE

(SPRAY TEST)

1. Install the nozzle to an injection nozzle hand tester and bleed air from the union nut.
2. Check injection pressure.
 - (1) Pump the tester handle 50 – 60 times per minute by hand.
 - (2) Read the injection starting pressure.

Opening pressure:

New nozzle

115 – 125 kg/cm²
(1,636 – 1,778 psi)

Reused nozzle

105 – 125 kg/cm²
(1,493 – 1,778 psi)

—Note—

1. Proper nozzle operation can be determined by a swishing sound.
2. If an overhauled nozzle is being used, adjust the injection starting pressure to 110 – 125 kg/cm² (1,565 – 1,778 psi).
3. To adjust the injection pressure, change the shim on the top of pressure spring.

—Note—

1. Shims are available in 20 sizes, in increments of 0.05 mm (0.0020 in.), from 1.00 – 1.95 mm (0.0394 – 0.0768 in.).
2. Varying the adjusting shim thickness by 0.05 mm (0.0020 in.) changes the injection pressure by about 5 kg/cm² (71 psi).

4. Check spray patterns.

- (1) Check the spray patterns when pumping the tester handle 50 – 60 times per minute by hand.

Fig. 2-37

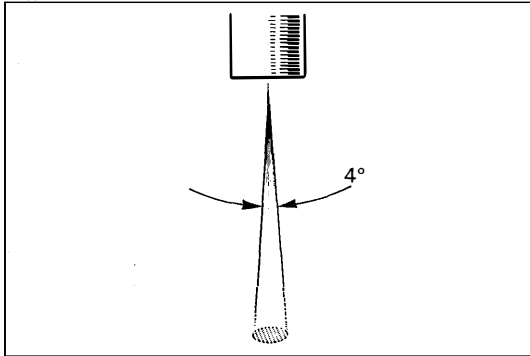

- (2) Spray should spread evenly down the nozzle center line in 4° conical form.
- (3) Place a white sheet of paper about 30 cm (11.8 in.) away from the nozzle to check if spray pattern is in circular form.

Fig. 2-38

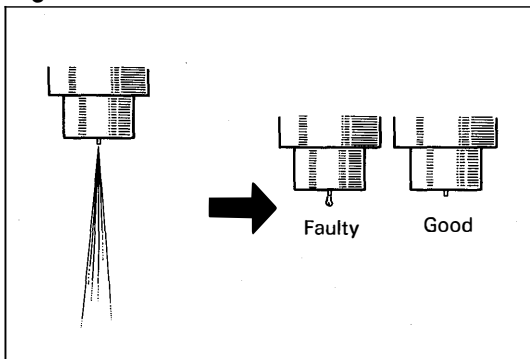

5. There should be no dripping after injection.

Fig. 2-39

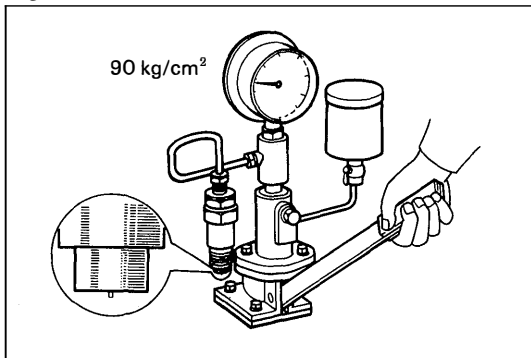

6. Test leakage. Apply 90 kg/cm² (1,280 psi) of fuel pressure, and check for leaks at the nozzle valve seat and retaining nut.

Fig. 2-40

**SEE
FUEL SYSTEM
NOZZLE CLEANING SECTION**

Fig. 6-32 to 6-38

NOZZLE CLEANING

Disassemble the nozzle holder and clean it with a nozzle cleaning kit.

Fig. 2-41

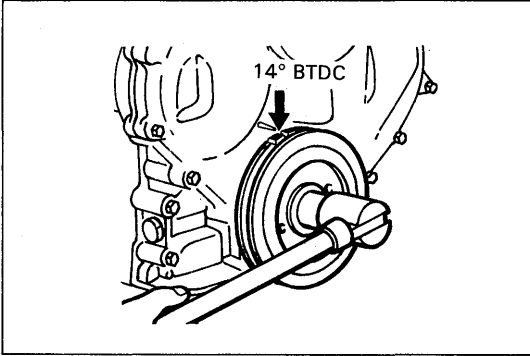

Fig. 2-42

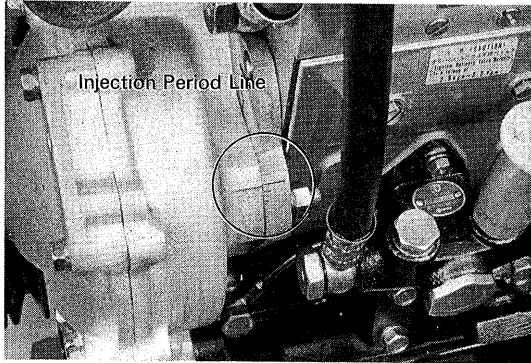

Fig. 2-43

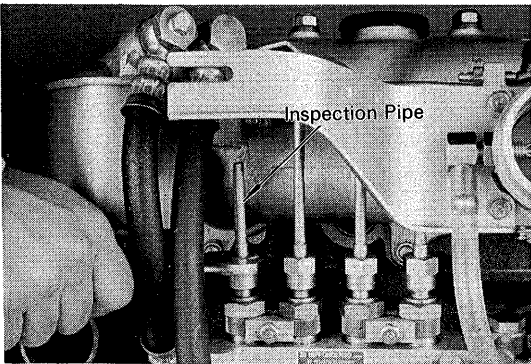
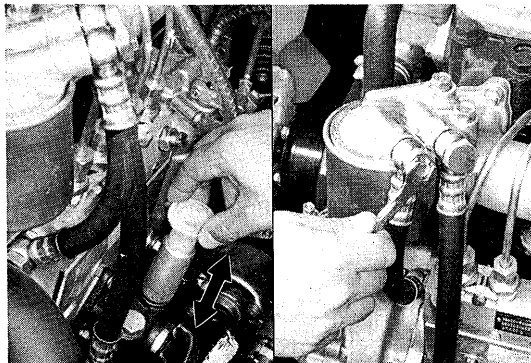

Fig. 2-44



INJECTION TIMING INSPECTION & ADJUSTMENT



1. Set the No.1 cylinder piston to the specified position.

Injection timing:

14° BTDC/compression



2. Set the aligning mark on the injection pump flange against the index mark on the timing gear case.

3. Check the injection timing.
 - (1) Install the inspection pipe on the No.1 delivery valve holder.

–Note–

Use as short an inspection pipe as possible.



- (2) Bleed air from the fuel filter by operating the priming pump.

Fig. 2-45

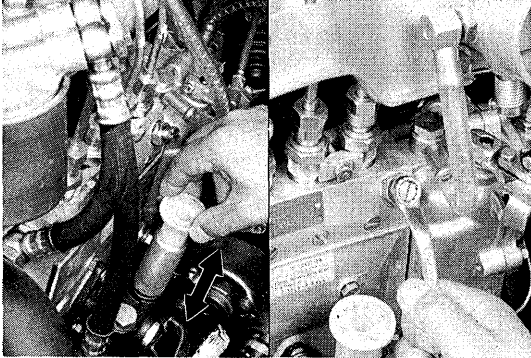

- (3) Bleed air from the injection pump by operating the priming pump.

Fig. 2-46

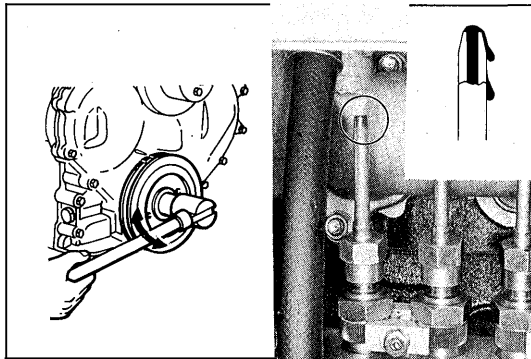

- (4) Rotate the crank pulley slightly to left and right. Repeat this action until fuel surfaces from the inspection pipe.

Fig. 2-47

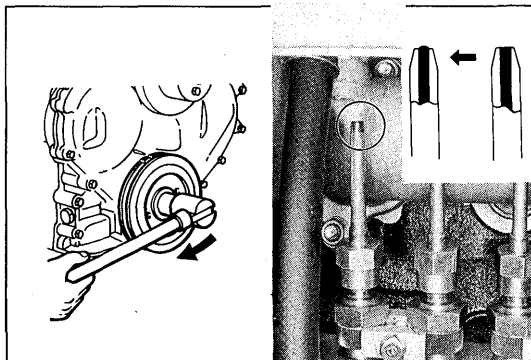

- (5) Slowly rotate the crank pulley. The fuel level in the inspection pipe should start to rise when the No.1 piston is at the specified position.

Injection timing:

14° BTDC/Compression

Fig. 2-48

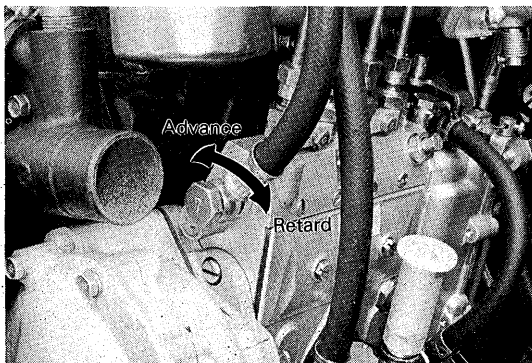

4. Adjust the injection timing by tilting the injection pump body slightly.
 To advance → Push upper part of the pump.
 To retard ← Pull upper part of the pump.
5. Recheck the injection timing.

—Note—

This operation should be repeated at least two or three times.

Fig. 2-49

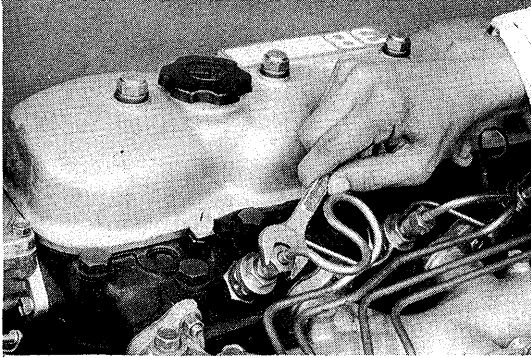

6. Remove the inspection pipe and install the No.1 injection pipe.

Fig. 2-50

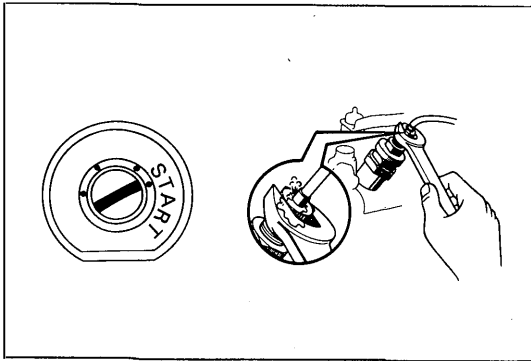

7. Bleed air from the injection pipe by activating the starter motor.
8. Start the engine and inspect all pipe lines for fuel leaks.

Fig. 2-51

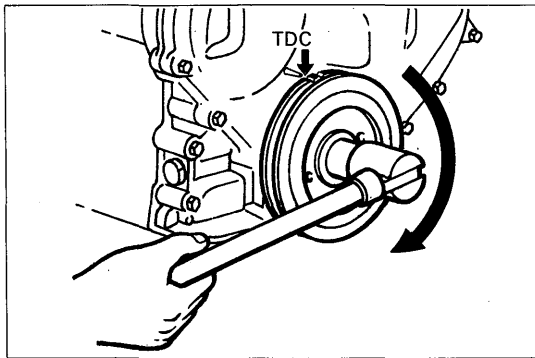

VALVE CLEARANCE ADJUSTMENT

1. Warm-up the engine.
2. Set No.1 cylinder to TDC/compression.
3. Retighten the head bolts and rocker support bolts.

Tightening torque:

Cylinder head bolts
 11.5 – 12.0 kg-m
 (84 – 86 ft-lb)

Rocker support bolts
 1.5 – 2.2 kg-m
 (11 – 15 ft-lb)

Fig. 2-52

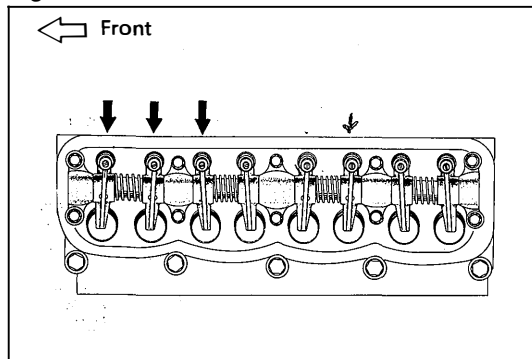

4. Adjust the valve clearance. The valve clearance is measured between the valve stem and rocker arm adjusting screw.

Adjust only the valves indicated by arrows.

Valve clearance:

IN 0.20 mm
 (0.008 in.)

EX 0.35 mm
 (0.014 in.)

Fig. 2-53

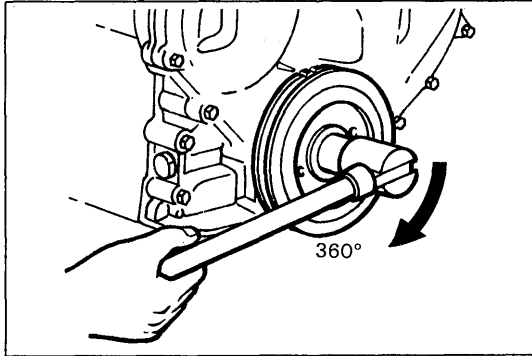

5. Rotate the crankshaft 360°.

Fig. 2-54

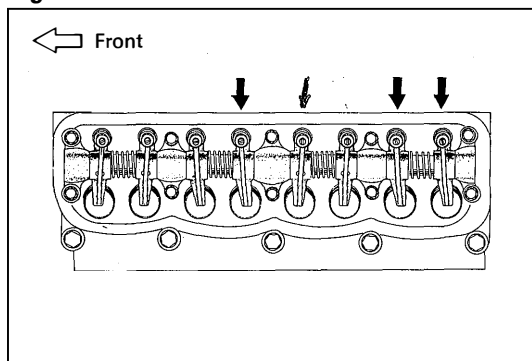

6. Adjust the remaining valves indicated by arrows.

Fig. 2-55

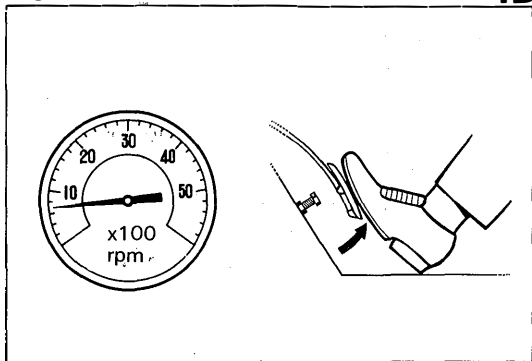

IDLE SPEED & MAXIMUM SPEED



INSPECTION & ADJUSTMENT

1. Warm-up the engine.
2. Check the engine idle speed.

Idle speed: 650 rpm

Fig. 2-56

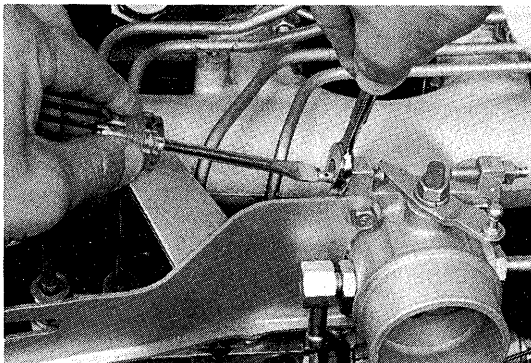

3. If necessary adjust the idle speed by turning the stop plate adjusting screw.

To rev up —→ Screw in

To reduce —→ Screw out

—Note—

After adjusting, be sure to lock the stop plate adjusting screw with a lock nut.

Fig. 2-57

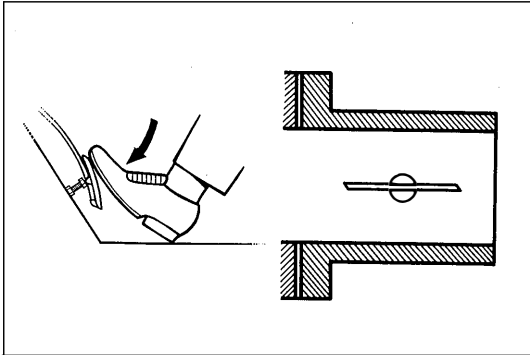

4. Make sure that the throttle valve is fully open when the accelerator pedal is depressed all the way.

Fig. 2-58

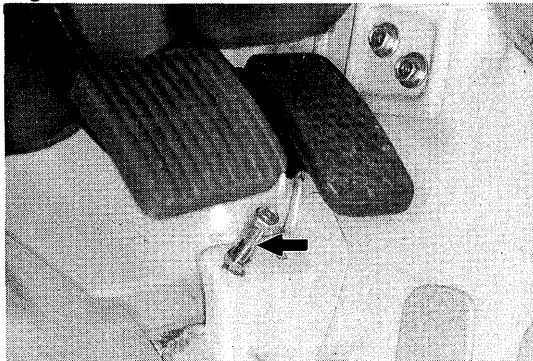

5. Make the full open adjustment through the accelerator pedal stop bolt.

Fig. 2-59

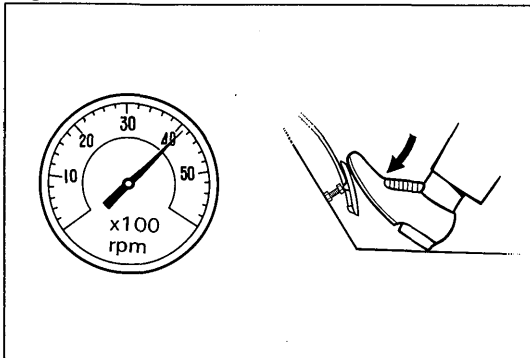

6. Check the engine maximum speed when the accelerator pedal is depressed all the way.

Maximum speed:
4,050 – 4,100 rpm

Fig. 2-60

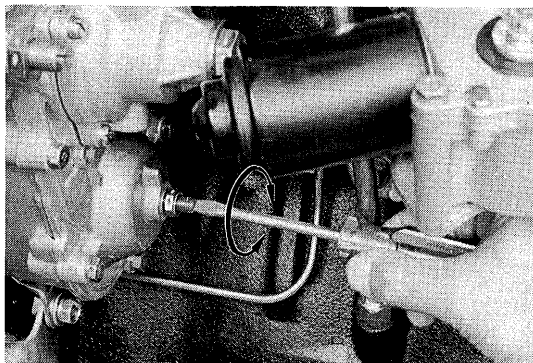

Adjust the maximum speed by turning the adjusting bolt if necessary.

To increase rpm → Screw in
To decrease rpm → Screw out

—Note—

After adjusting, be sure to lock the adjusting bolt with the lock nut and tighten the cap nut.

Then, seal the cap nut with wire.

ENGINE SERVICE

	Page
CUTAWAY VIEW	3-2
CYLINDER HEAD	3-4
TIMING GEAR	3-23
CYLINDER BLOCK	3-34

CUTAWAY VIEW

Fig. 3-1

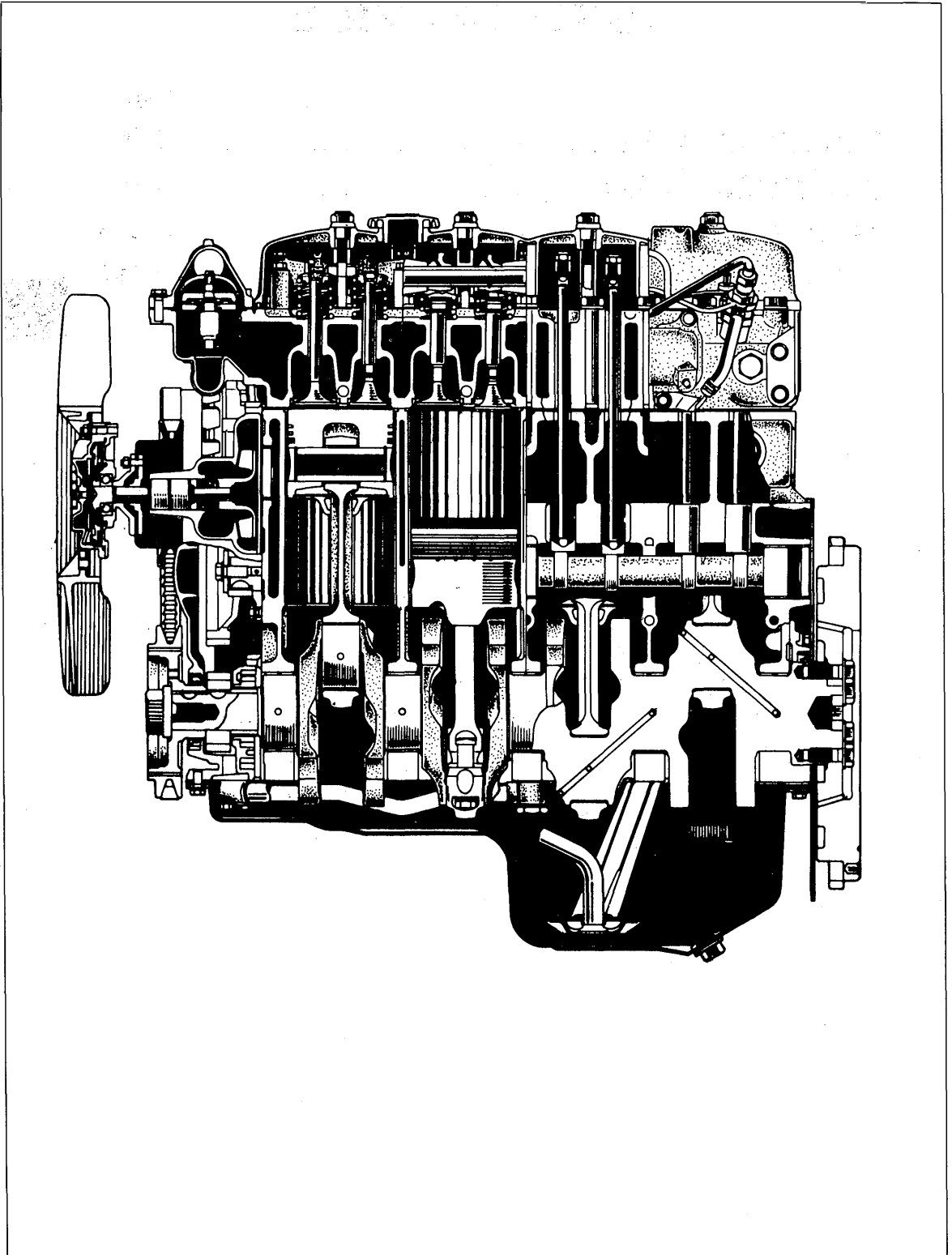
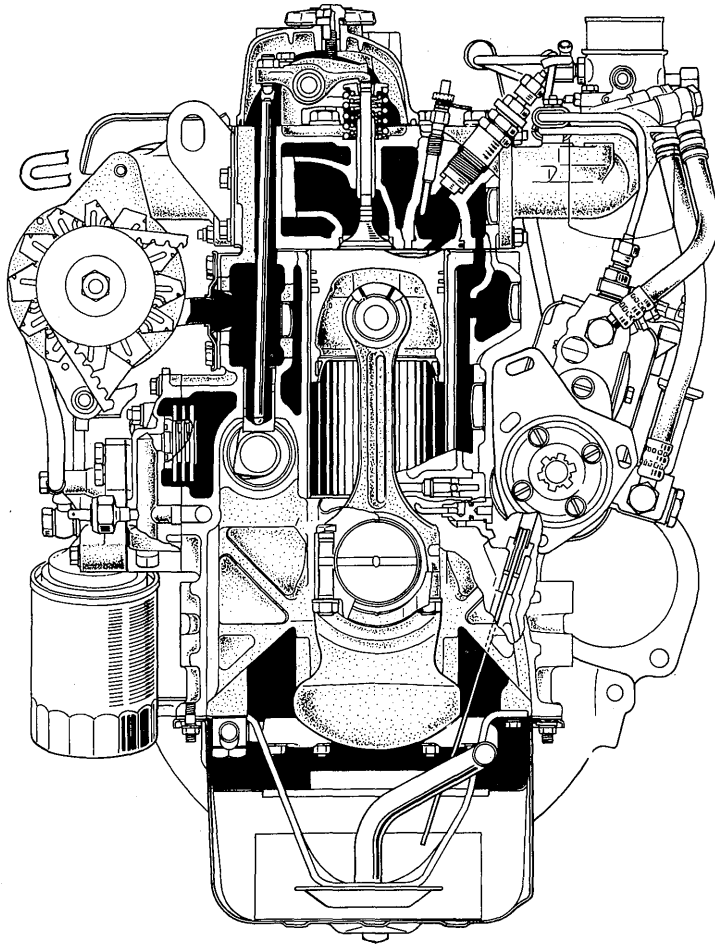

Fig. 3-2



CYLINDER HEAD

DISASSEMBLY

Disassemble the parts in the numerical order shown in the figure.

Fig. 3-3

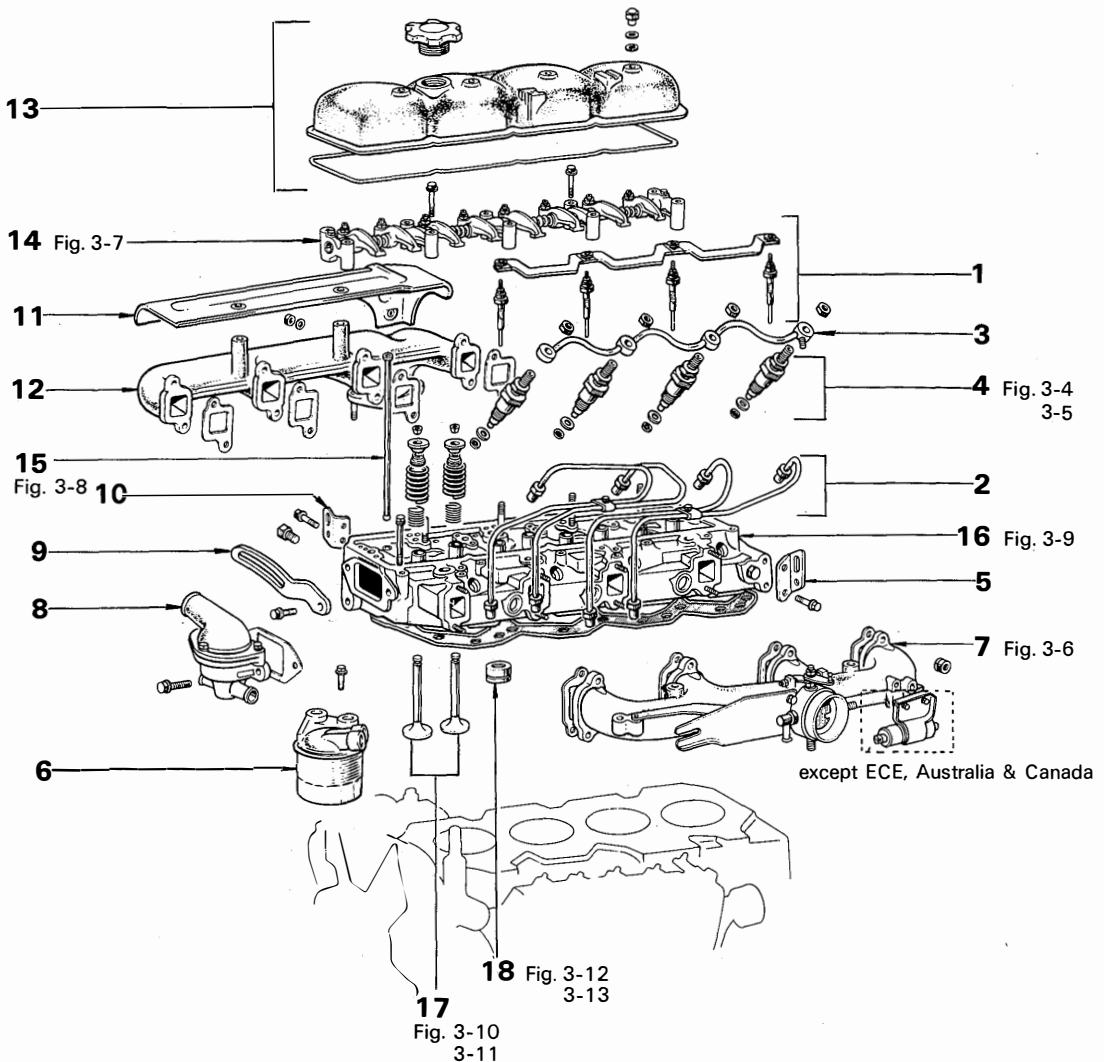

- | | |
|--|----------------------------------|
| 1. Glow Plug & Glow Plug Connector | 10. Front Engine Hanger |
| 2. Injection Pipe | 11. Heat Insulator (for 3B) |
| 3. Leakage Pipe | 12. Exhaust Manifold |
| 4. Injection Nozzle Holder & Gasket | 13. Cylinder Head Cover & Gasket |
| 5. Rear Engine Hanger | 14. Valve Rocker Shaft Assembly |
| 6. Fuel Filter | 15. Valve Push Rod |
| 7. Intake Manifold with Overinjection Magnet | 16. Cylinder Head |
| 8. Water Outlet Housing | 17. Valve & Compression Spring |
| 9. V Belt Adjusting Bar | 18. Combustion Chamber |

Fig. 3-4



Remove the injection nozzle holders with SST. SST (09268-46011) of set [09260-46011]

Fig. 3-5

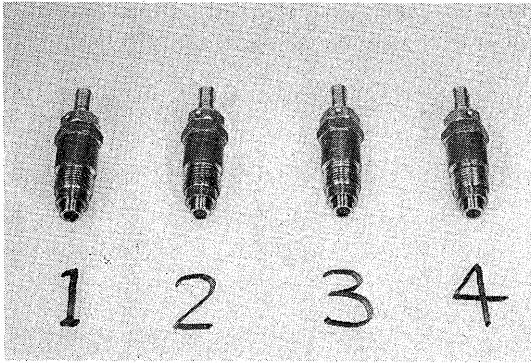

Keep the nozzle holders in correct order.

Fig. 3-6

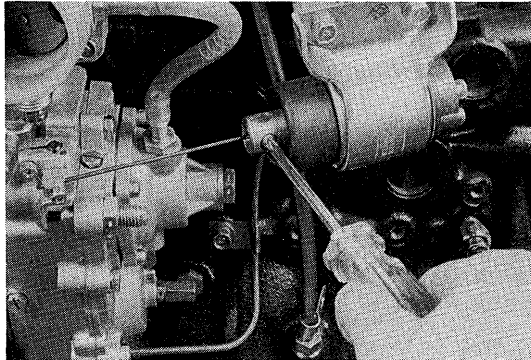

Disconnect the overinjection magnet connecting wire and remove the intake manifold.

—Note—

The overinjection magnet is not equipped on vehicles for ECE, Australia and Canada.

Fig. 3-7

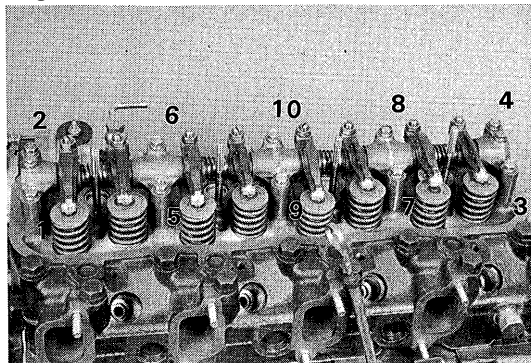

Loosen each rocker support bolt a little at a time in the sequence shown in the figure.

Fig. 3-8

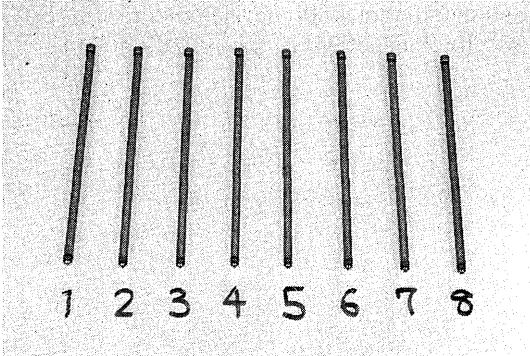

Keep the push rods in correct order.

Fig. 3-9

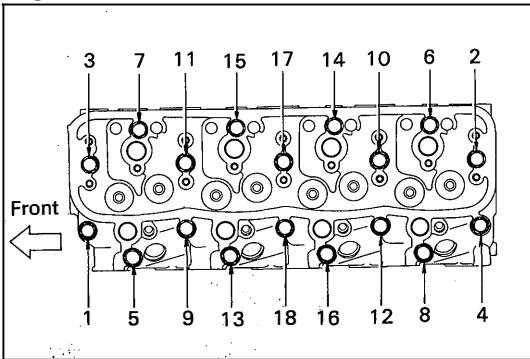

Loosen each cylinder head bolt a little at a time in the sequence shown in the figure.

Fig. 3-10

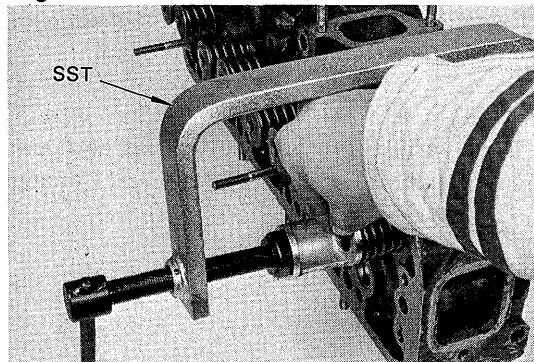

Compress the valve spring with SST and remove the spring retainer locks. SST [09202-43012]

Fig. 3-11

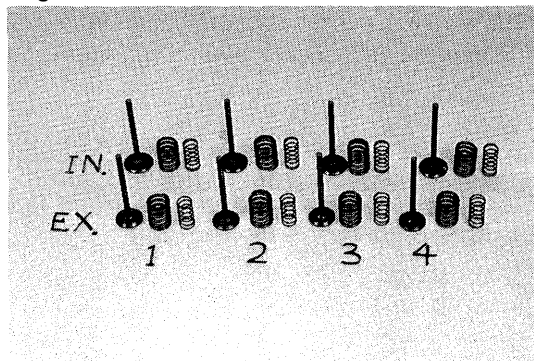

Keep the valves and springs in correct order.

Fig. 3-12

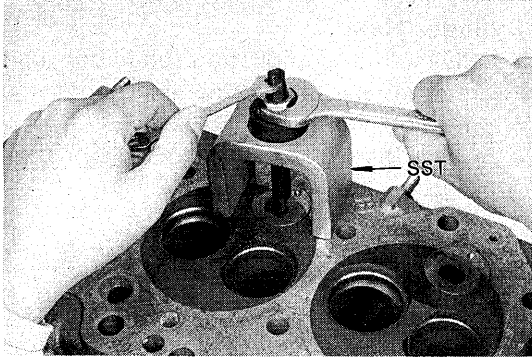

Pull out the combustion chamber with SST.
SST [09208-48010]

-Note-

Be careful not to damage the hole.

Fig. 3-13

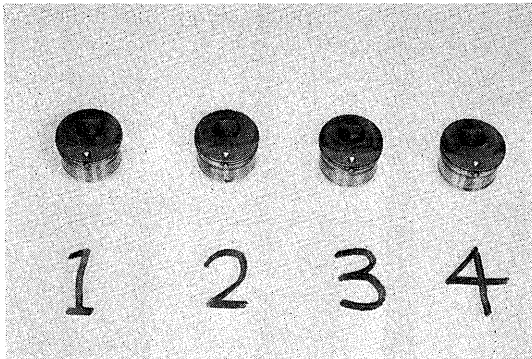

Keep the combustion chambers in correct order.

Fig. 3-14

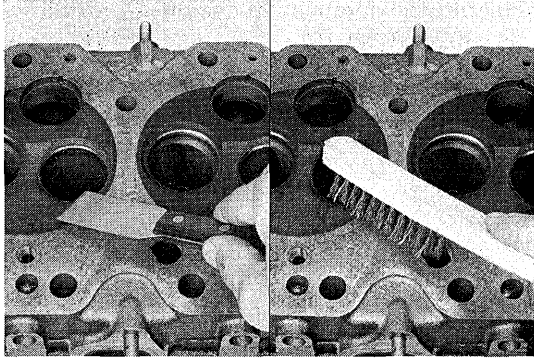
**INSPECTION & REPAIR****Cylinder Head**

1. Clean the combustion chamber and remove any gasket material from the manifold and head surface.

Check the cylinder head for cracks or scoring.

Fig. 3-15

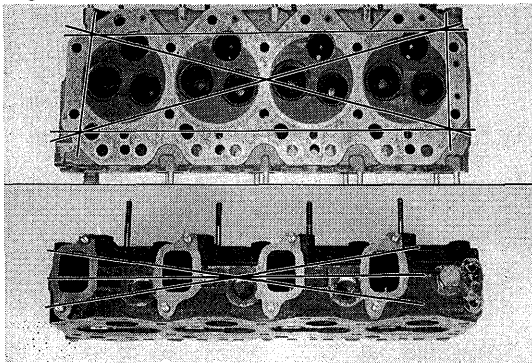

2. Check the surface along the indicated areas for warp.

Fig. 3-16

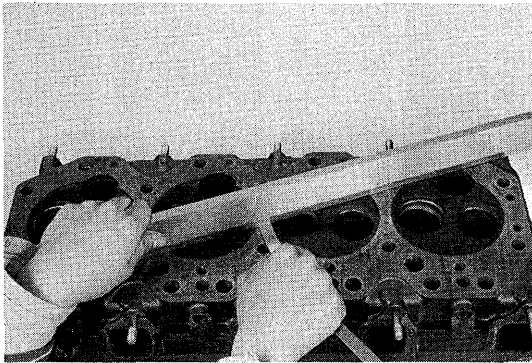

- (1) Using a precision straight-edge and thickness gauge, check the cylinder head surface for warpage.

Underside surface warpage:

**Limit 0.2 mm
(0.008 in.)**

Fig. 3-17

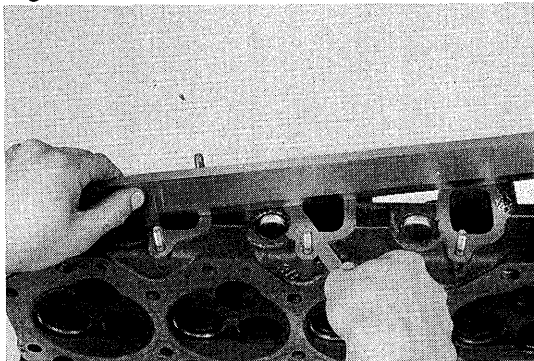

- (2) Check the intake and exhaust manifold mounting surfaces for warpage.

Manifold mounting surface warpage:

**Limit 0.2 mm
(0.008 in.)**

3. If the warp exceeds the limit, replace the cylinder head.

Fig. 3-18

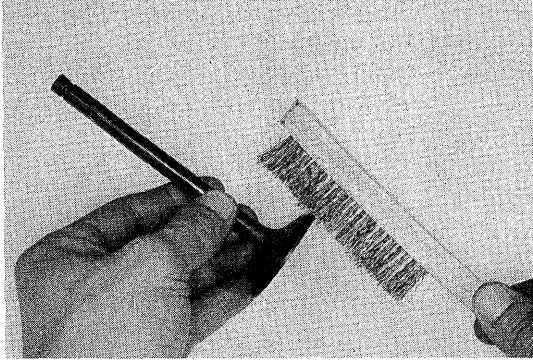

Valve & Guide

1. Clean the valve and check for wear, scoring and bending.

Fig. 3-19

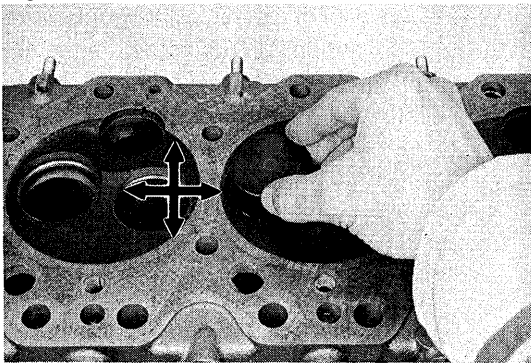

2. Check the valve stem to valve guide clearance.
 - (1) Insert the valve stem into the guide.
 - (2) Move the valve back and forth and check the clearance as shown in the figure.

Fig. 3-20

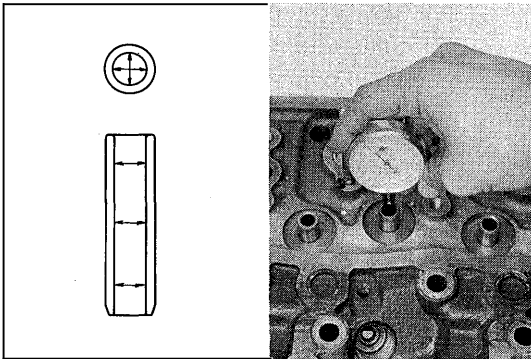

3. Check the valve stem oil clearance.
 - (1) Measure the inside diameter of the valve guide at several places with an inside dial gauge.

Guide inside diameter:

STD IN & EX

9.01 – 9.03 mm

(0.3547 – 0.3555 in.)

- (2) Measure the valve stem diameter.

Stem diameter:

STD IN 8.968 – 8.984 mm

(0.3531 – 0.3537 in.)

EX 8.954 – 8.970 mm

(0.3525 – 0.3531 in.)

Fig. 3-21

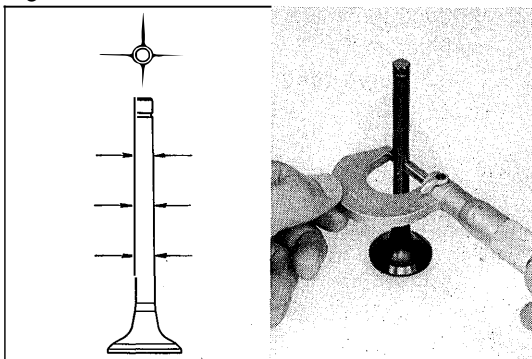

- (3) Calculate the valve stem oil clearance.

Stem oil clearance:

STD IN 0.026 – 0.062 mm

(0.0010 – 0.0024 in.)

EX 0.040 – 0.076 mm

(0.0016 – 0.0030 in.)

Limit IN 0.10 mm (0.0039 in.)

EX 0.12 mm (0.0047 in.)

—Note—

Measure at several places and use the maximum wear for calculation.

Fig. 3-22

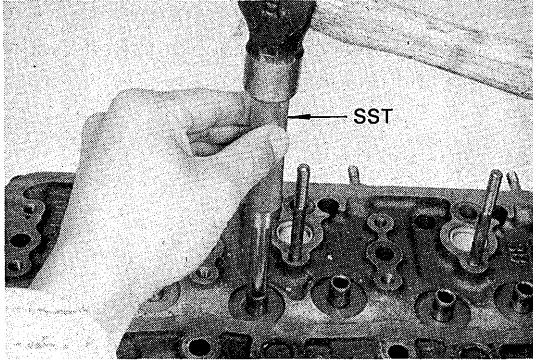

4. If the oil clearance exceeds the limit, replace both the guide and valve.

- (1) Using SST, drive out the valve guide from the top end toward the combustion chamber.
SST [09201-60011]

Fig. 3-23

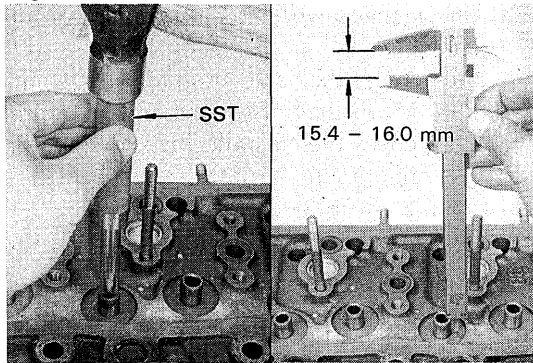

- (2) Drive in the new valve guide with SST until its tip projects from the top of the cylinder head by the length specified below.
SST [09201-60011]

Protrusion from cylinder head:

15.4 - 16.0 mm
(0.606 - 0.630 in.)

Fig. 3-24

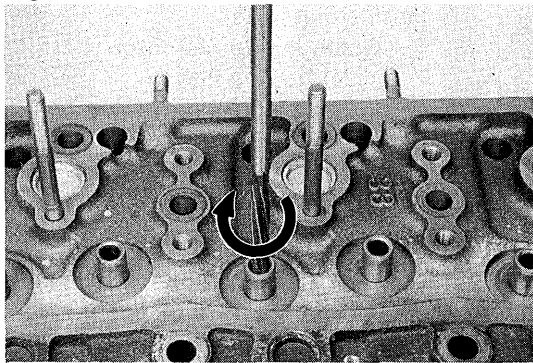

- (3) With a sharp reamer, ream the valve guide to obtain specified clearance.

Oil clearance:

IN 0.026 - 0.062 mm
(0.0010 - 0.0024 in.)
EX 0.040 - 0.076 mm
(0.0016 - 0.0030 in.)

Fig. 3-25

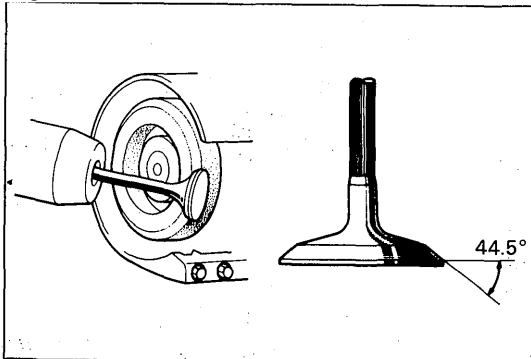

5. Reface the valve seating face with a valve refacer.

Valve face angle: 44.5°

Fig. 3-26

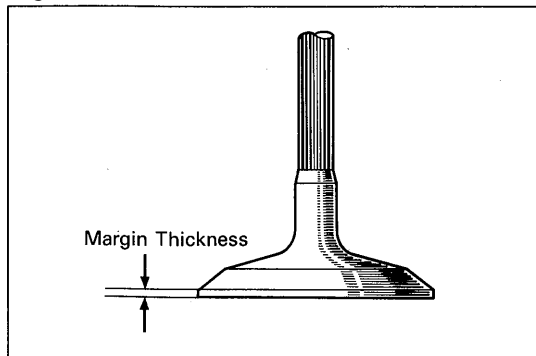

6. Check the valve head margin thickness.

Margin thickness:

Limit IN	0.9 mm
	(0.035 in.)
EX	1.3 mm
	(0.051 in.)

Fig. 3-27

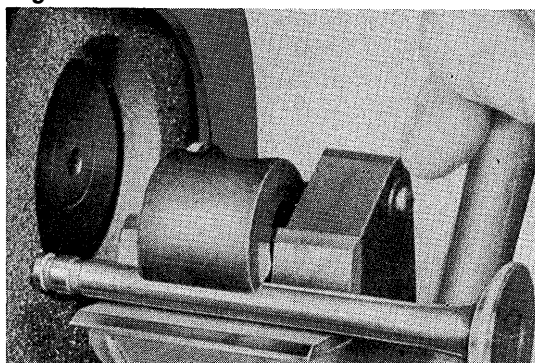

7. Check the valve stem tip.
If necessary, resurface the valve stem tip with a valve grinder.

Stem tip resurfacing:

Limit	0.5 mm
	(0.020 in.)

Overall length:

IN	127.95 mm
	(5.0374 in.)
EX	127.75 mm
	(5.0295 in.)

Fig. 3-28

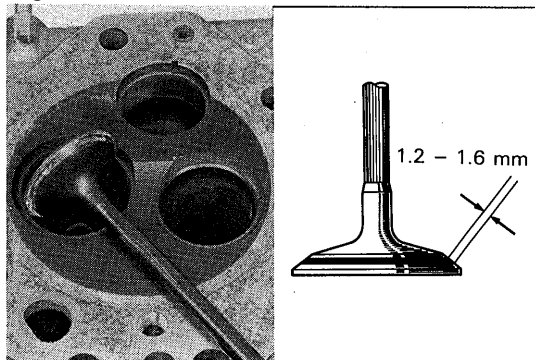

Valve Seat

1. Check the valve seat contact. Coat the valve face with prussian blue or red lead. Locate contact point on valve by rotating the valve against seat.

Contact width:

1.2 - 1.6 mm
(0.047 - 0.063 in.)

Contact position:

Middle of valve face

Fig. 3-29

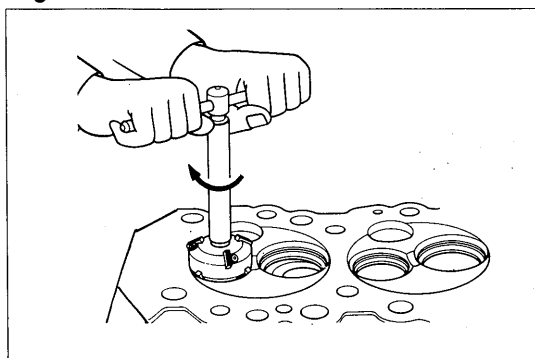

2. Resurface the valve seat with a 45° cutter.

Fig. 3-30

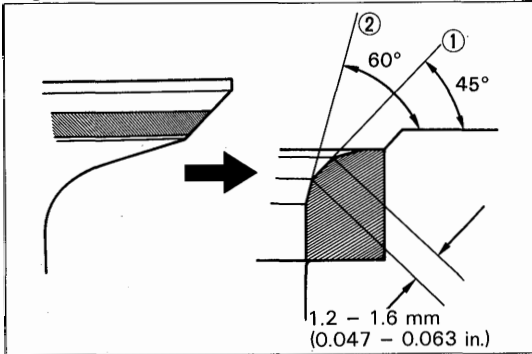

3. Correct the seat position.
 - (1) If the seat position is too high, use 45° and 60° cutters in the order indicated in the figure.

Fig. 3-31

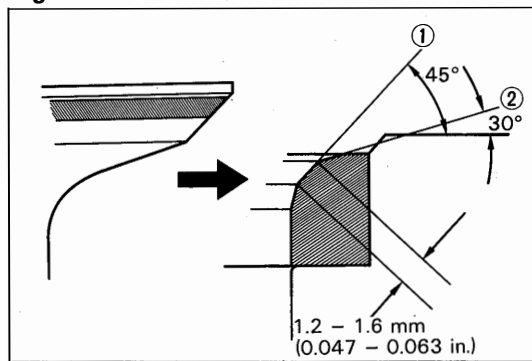

- (2) If the seat position is too low, use 45° and 30° cutters in the order indicated in the figure.

Fig. 3-32

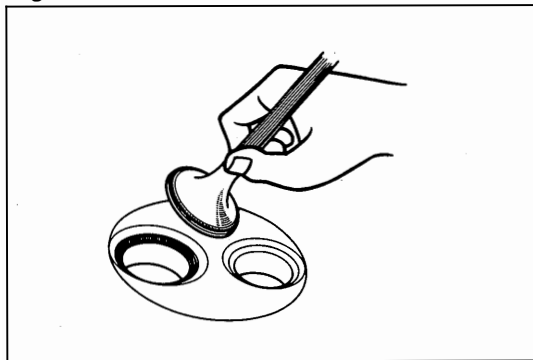

4. Check the valve concentricity.
 - (1) Lightly coat the seat with prussian blue.
 - (2) Install the valve and rotate it. If blue appears 360° around face, the valve stem and face are concentric. If not, replace the valve.

Fig. 3-33

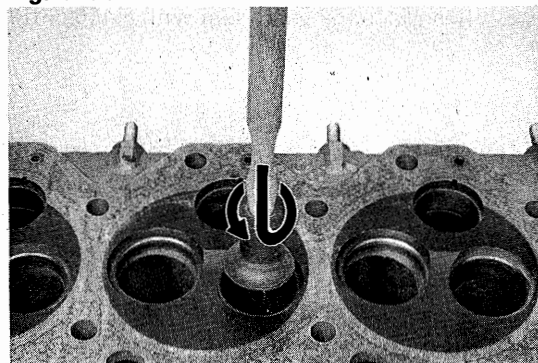

5. After correction, the valve and valve seat should be lapped lightly with a lapping compound.

Fig. 3-34

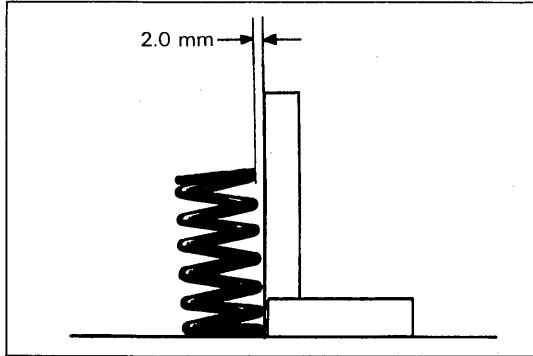
**Valve Spring**

1. Check the squareness of the valve spring with a square.

Squareness:

Limit 2.0 mm
(0.079 in.)

Fig. 3-35

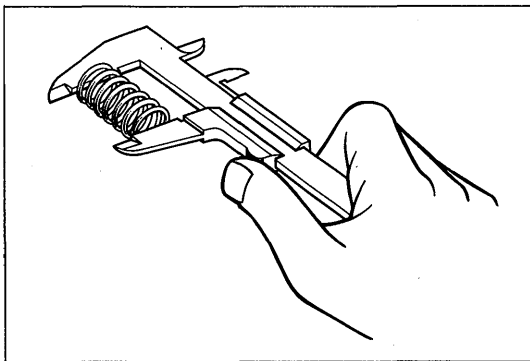

2. Measure free length of the spring.

Free length:

Outer 45.5 mm
(1.791 in.)

Inner 47.5 mm
(1.870 in.)

Fig. 3-36

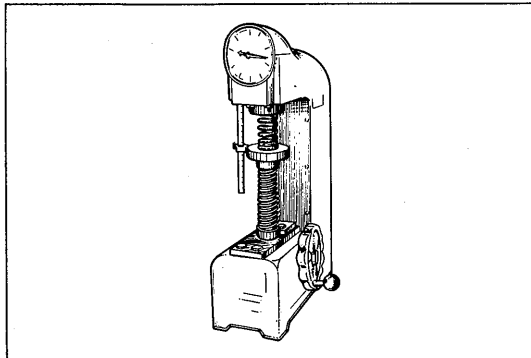

3. Using a spring tester, measure the tension of each spring at the specified installed length. Replace any spring that does not meet specification.

Installed length:

Outer 39.6 mm (1.559 in.)

Inner 36.1 mm (1.421 in.)

Installed load:

STD Outer 25.6kg (56.4 lb)

Inner 5.95kg (13.1 lb)

Limit Outer 21.0kg (46.3 lb)

Inner 4.9kg (10.8 lb)

Fig. 3-37

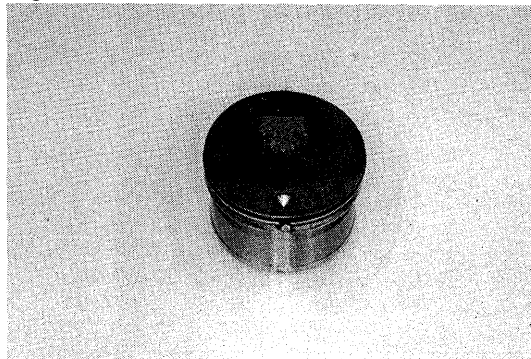
**Combustion Chamber**

Clean or check for cracks or damages.

Fig. 3-38

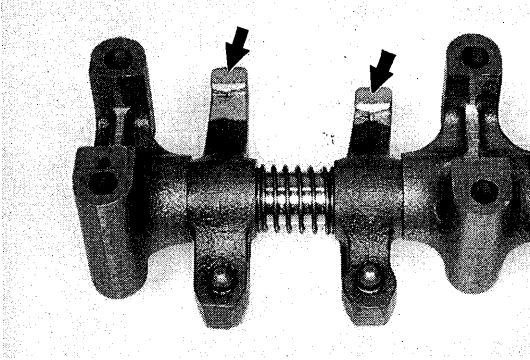
**Rocker Arm & Shaft**

1. Check the valve contacting surface of the rocker arm for wear. Correct or replace if necessary.

Fig. 3-39

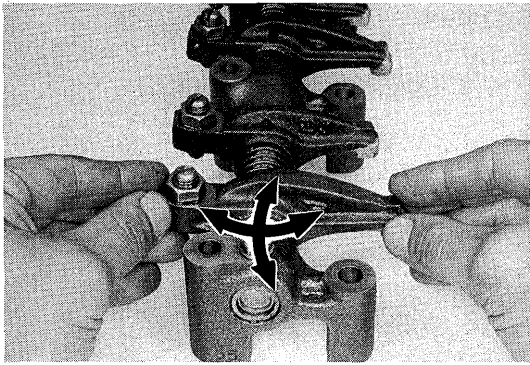

2. Check the rocker arm to shaft clearance. If worn excessively, disassemble and inspect.

3. Disassemble the valve rocker shaft assembly in the numerical order shown in the figure.

—Note—

Keep the rocker arms in correct order.

Fig. 3-40

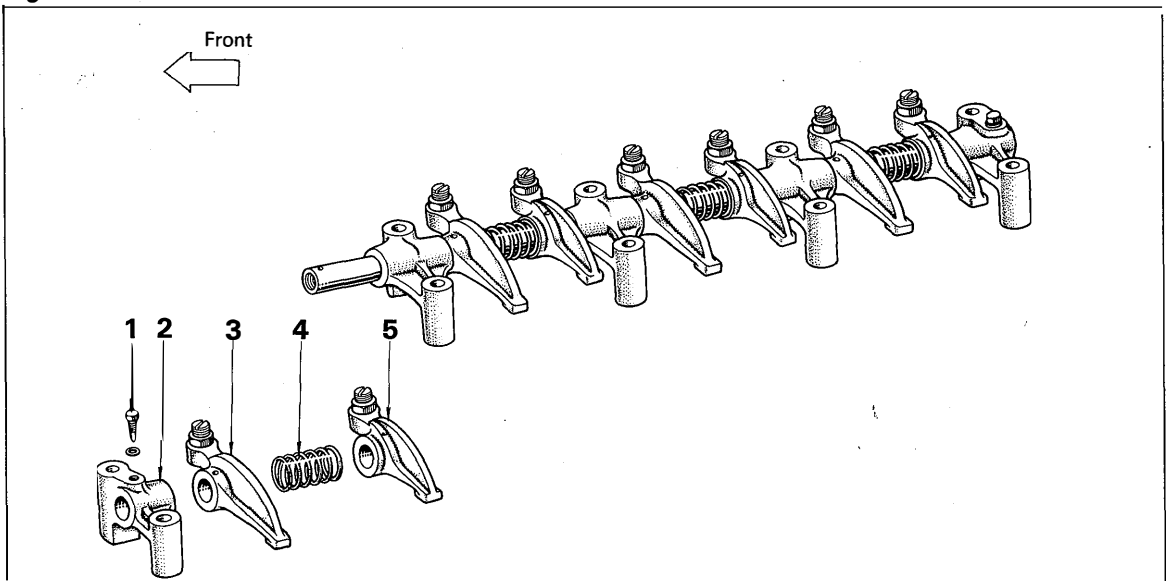

Fig. 3-41

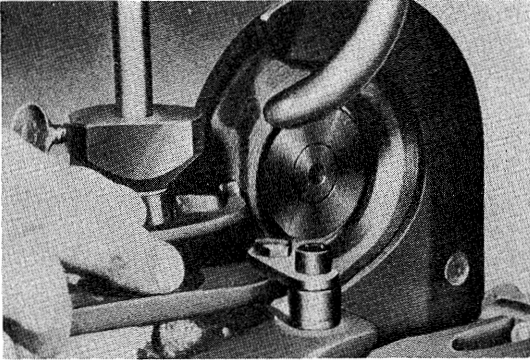
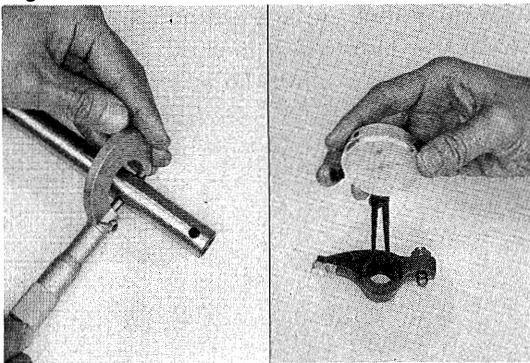

Fig. 3-42



4. If only a light ridged wear, correct the valve contacting surface of the rocker arm with a valve refacer and oil stone.

5. Measure oil clearance between the rocker arm and shaft.

Shaft diameter:

Limit 18.44 mm
(0.7260 in.)

Rocker arm bore:

Limit 18.60 mm
(0.7323 in.)

Oil clearance:

STD 0.02 – 0.06 mm
(0.0008 – 0.0024 in.)

Limit 0.1 mm
(0.004 in.)

6. Assemble the valve rocker shaft assembly in the numerical order shown in the figure

—Note—

Align the oil hole of front rocker support with the oil hole of the shaft.

Fig. 3-43

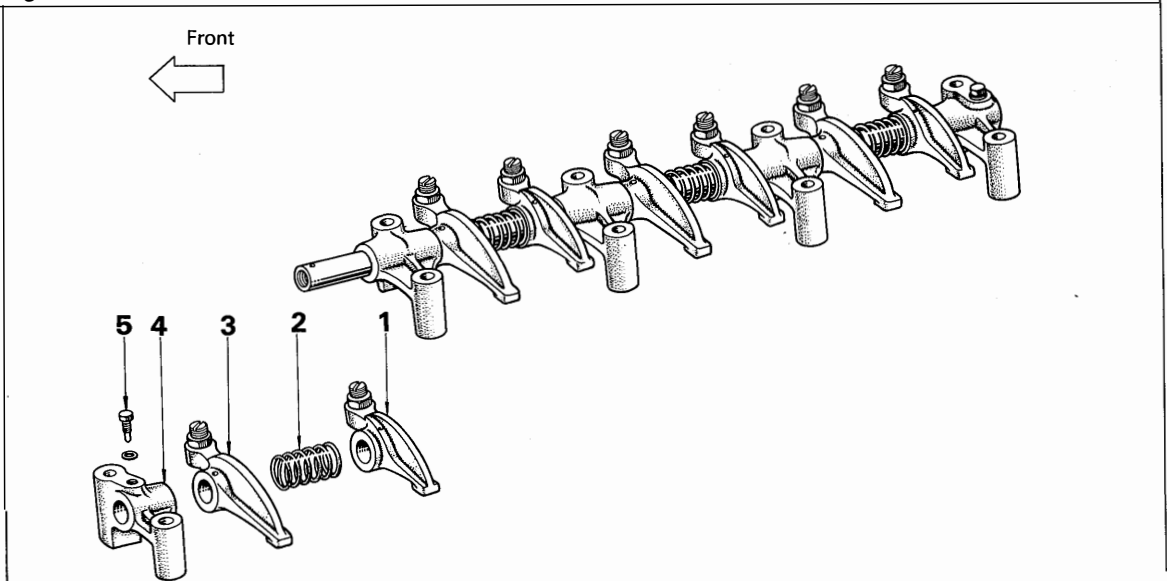
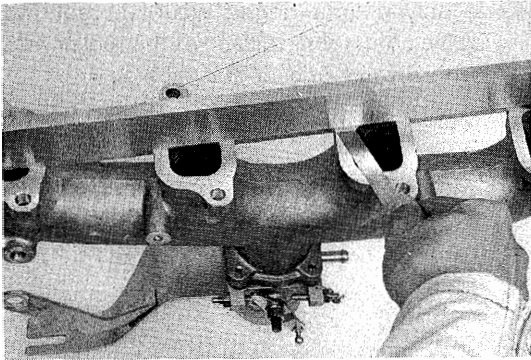

Fig. 3-44

**Manifold**

Using a straight edge and thickness gauge, check the cylinder head contacting surfaces for warpage.

Replace the manifold if it exceeds the limit.

Fig. 3-45

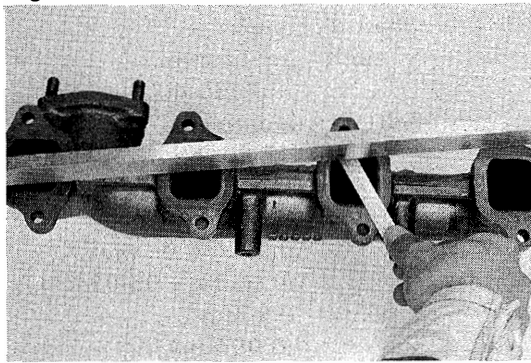
**Installing surface warpage:**

Limit 0.4 mm

(0.016 in.)

Fig. 3-46

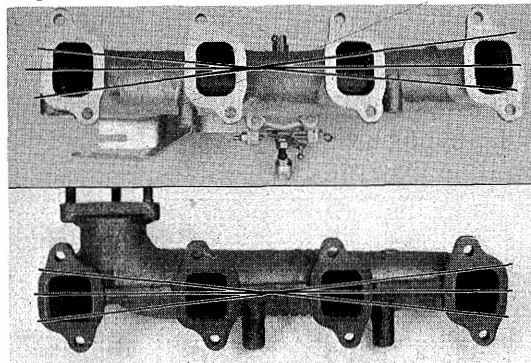

—Note—

Check at three positions as shown in the figure.

ASSEMBLY

Assemble the parts in the numerical order shown in the figure.

Fig. 3-47

-Note-

1. Thoroughly clean all parts to be assembled.
2. Apply clean engine oil to all sliding and rotating surfaces of the parts before assembly.

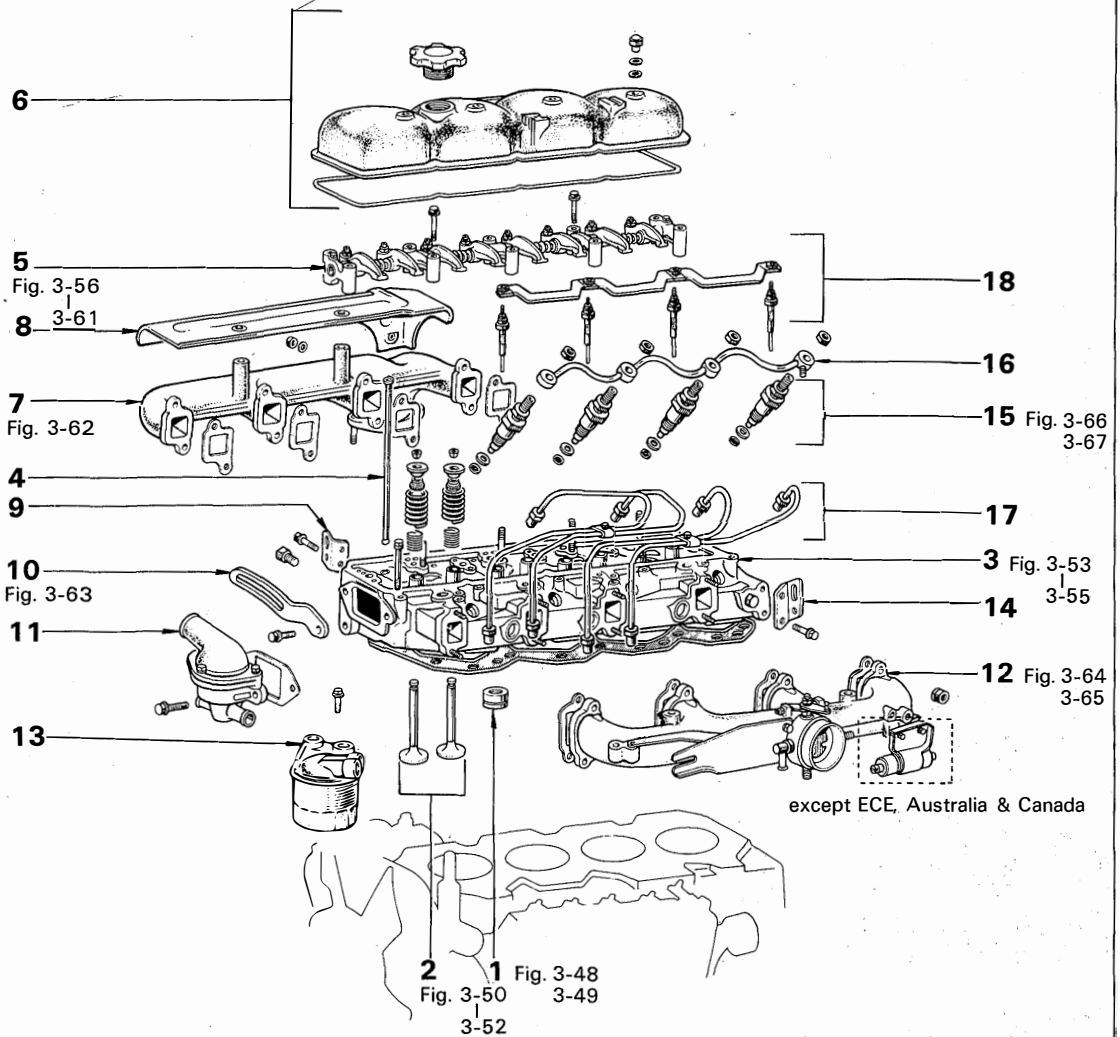

except ECE, Australia & Canada

- | | |
|---------------------------------|---|
| 1. Combustion Chamber | 11. Water outlet Housing |
| 2. Valve & Compression Spring | 12. Intake Manifold with Overinjection Magnet |
| 3. Cylinder Head | 13. Fuel Filter |
| 4. Valve Push Rod | 14. Rear Engine Hanger |
| 5. Valve Rocker Shaft Assembly | 15. Injection Nozzle Holder & Gasket |
| 6. Cylinder Head Cover & Gasket | 16. Leakage Pipe |
| 7. Exhaust Manifold | 17. Injection Pipe |
| 8. Heat Insulator (for 3B) | 18. Glow Plug & Glow Plug Connector |
| 9. Front Engine Hanger | |
| 10. V Belt Adjusting Bar | |

Fig. 3-48

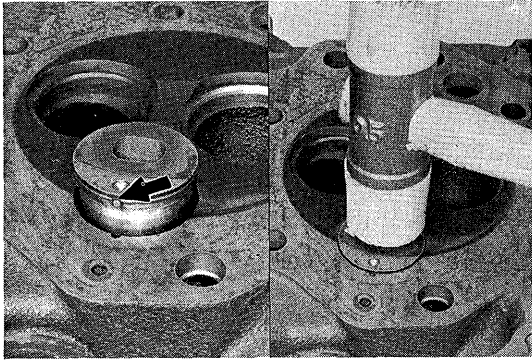

Match the combustion chamber knock pin with the cylinder head cutout and drive in the combustion chamber.

Fig. 3-49

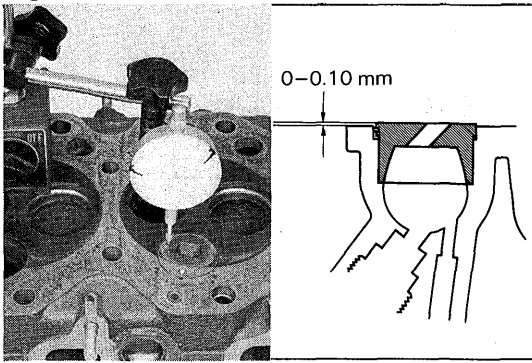

Check the combustion chamber protrusion.

Combustion chamber protrusion:

0 – 0.10 mm
(0 – 0.0039 in.)

Fig. 3-50

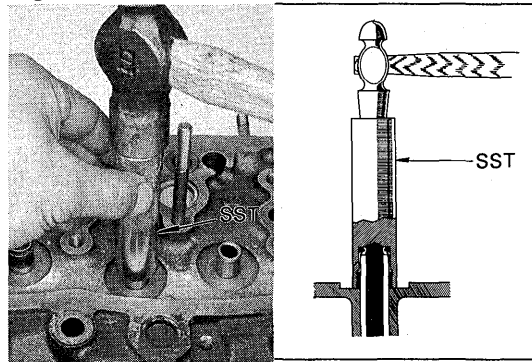

Drive in the oil seal with SST.
SST [09201-54010]

—Note—

1. A new oil seal should be used whenever the valve is disassembled.
2. Coat the oil seal lip with engine oil.

Fig. 3-51

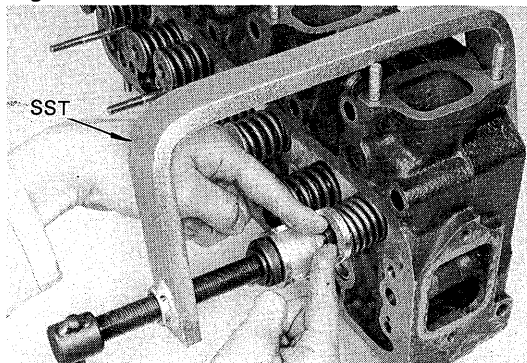

Compress the valve spring with SST and insert the spring retainer locks.
SST [09202-43012]

Fig. 3-52

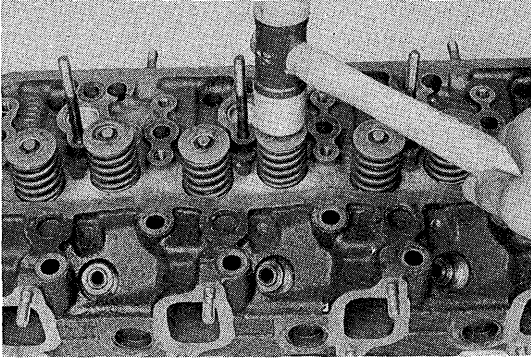

After installing the springs, lightly tap on the stem ends and allow the springs to settle down snugly.

Fig. 3-53

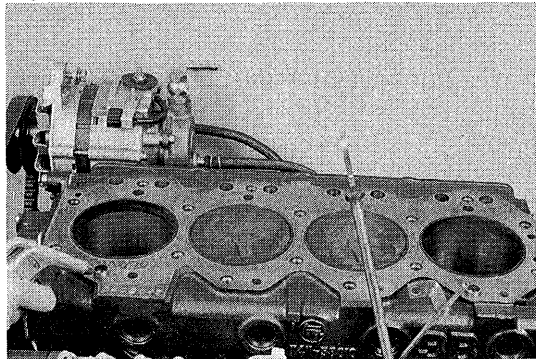

Place the cylinder head gasket on the cylinder block and align the bolt holes.

—Note—

1. Clean the cylinder block bolt holes with compressed air.
2. Clean the cylinder block upper surface with a scraper before installing the head gasket.

Fig. 3-54

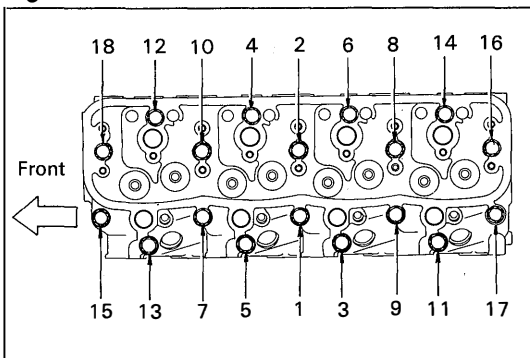

Tighten each cylinder head bolt a little at a time in the sequence shown in the figure.

—Note—

Apply a light coating of engine oil on the bolt threads and under the bolt head before installing.

Fig. 3-55

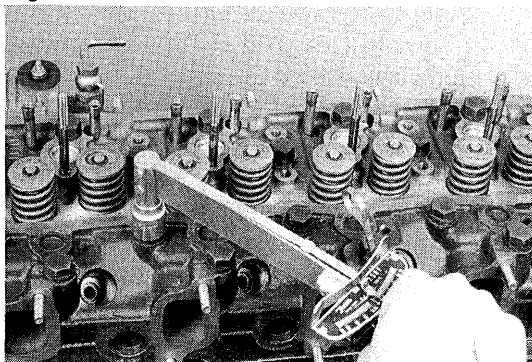

Tighten the cylinder head bolts to specified torque.

Tightening torque:

11.5 – 12.0 kg-m
(84 – 86 ft-lb)

Fig. 3-56

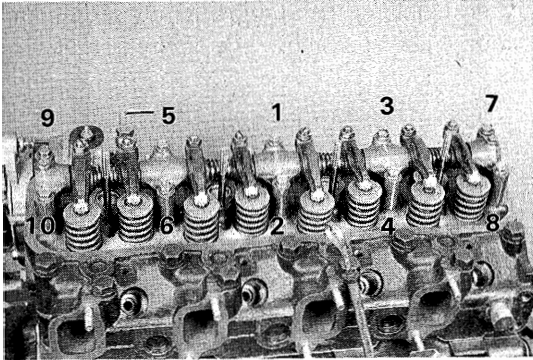

Tighten the valve rocker support bolts to specified torque.

—Note—

Do not keep the valve push rods apart from the adjusting screws while tightening the bolts.

Fig. 3-57

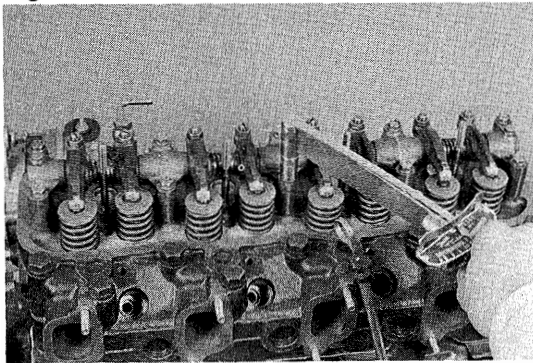

Tighten the valve rocker support bolts to specified torque.

**Tightening torque: 1.5 – 2.2 kg-m
(11 – 15 ft-lb)**

Fig. 3-58

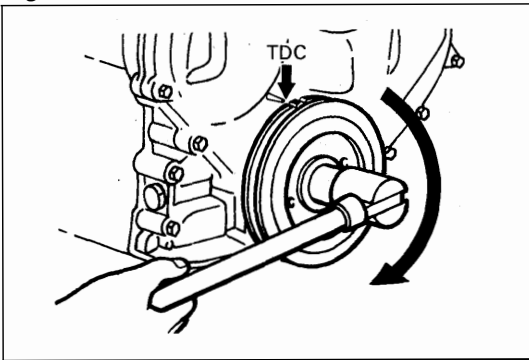

Temporarily adjust the valve clearance.

1. Set No. 1 cylinder to TDC/compression.

Fig. 3-59

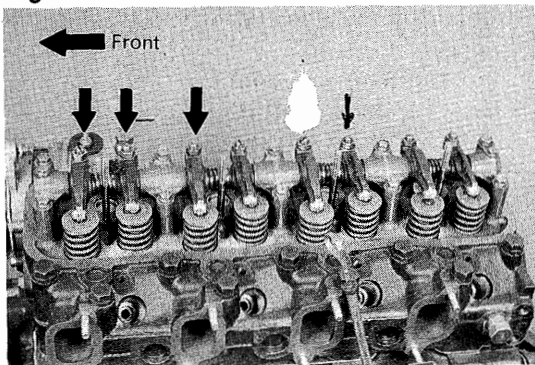

2. Adjust the valve clearance. The valve clearance is measured between the valve stem and rocker arm adjusting screw.

Adjust only the valves indicated by arrows.

Valve clearance:

**IN 0.20 mm
(0.008 in.)**

**EX 0.36 mm
(0.014 in.)**

Fig. 3-60

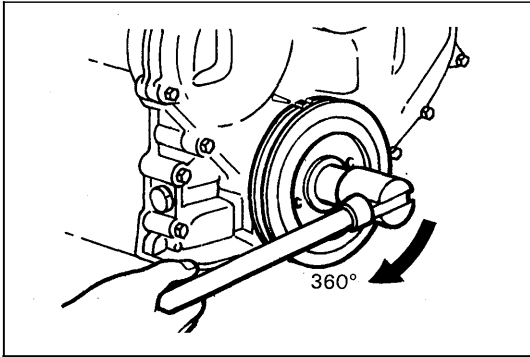

3. Rotate the crankshaft 360°.

Fig. 3-61

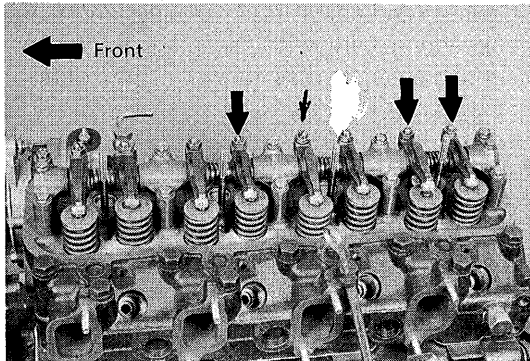

4. Adjust the remaining valves indicated by arrows.

Fig. 3-62

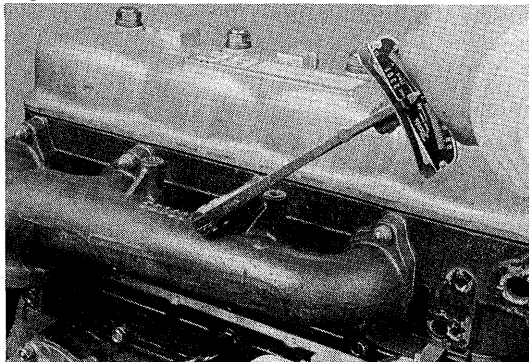

Install the exhaust manifold.

**Tightening torque: 3.0 – 4.5 kg-m
(22 – 32 ft-lb)**

Fig. 3-63

SEE
ENGINE TUNE-UP
SECTION
Fig. 2-7 & 2-8

Adjust drive belt tension.

Fig. 3-64

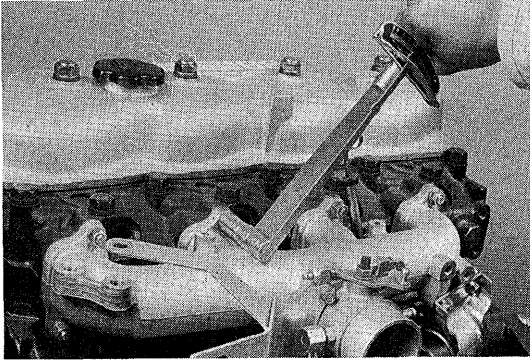

Install the intake manifold.

Tightening torque: 1.5 – 2.2 kg-m
(11 – 15 ft-lb)

Fig. 3-65

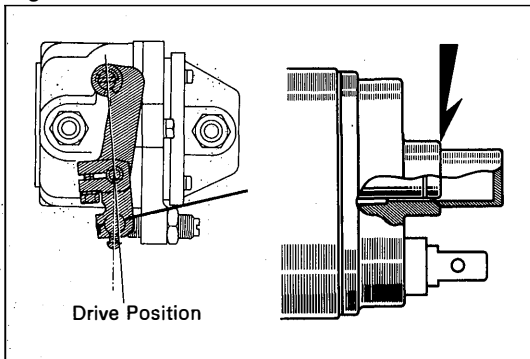

Connect and adjust the overinjection magnet connecting wire with the magnet core end surface positioned as shown in the figure.

—Note—

The overinjection magnet is not equipped on vehicles for ECE, Australia and Canada.

Fig. 3-66

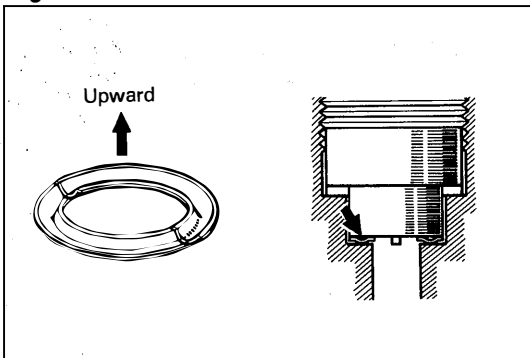

Note the orientation of the nozzle seat gasket as shown in the figure.

—Note—

Be sure to check the gasket before installing the nozzle holder.

Fig. 3-67

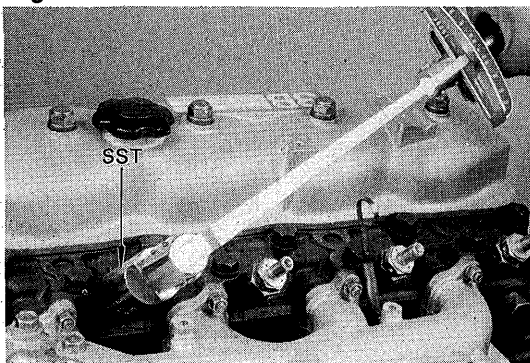

Tighten the nozzle holders with SST.

SST (09268-46011) of set [09260-46011]

Tightening torque: 6.0 – 8.0 kg-m
(44 – 57 ft-lb)

TIMING GEAR

DISASSEMBLY

Disassemble the parts in the numerical order shown in the figure.

Fig. 3-68

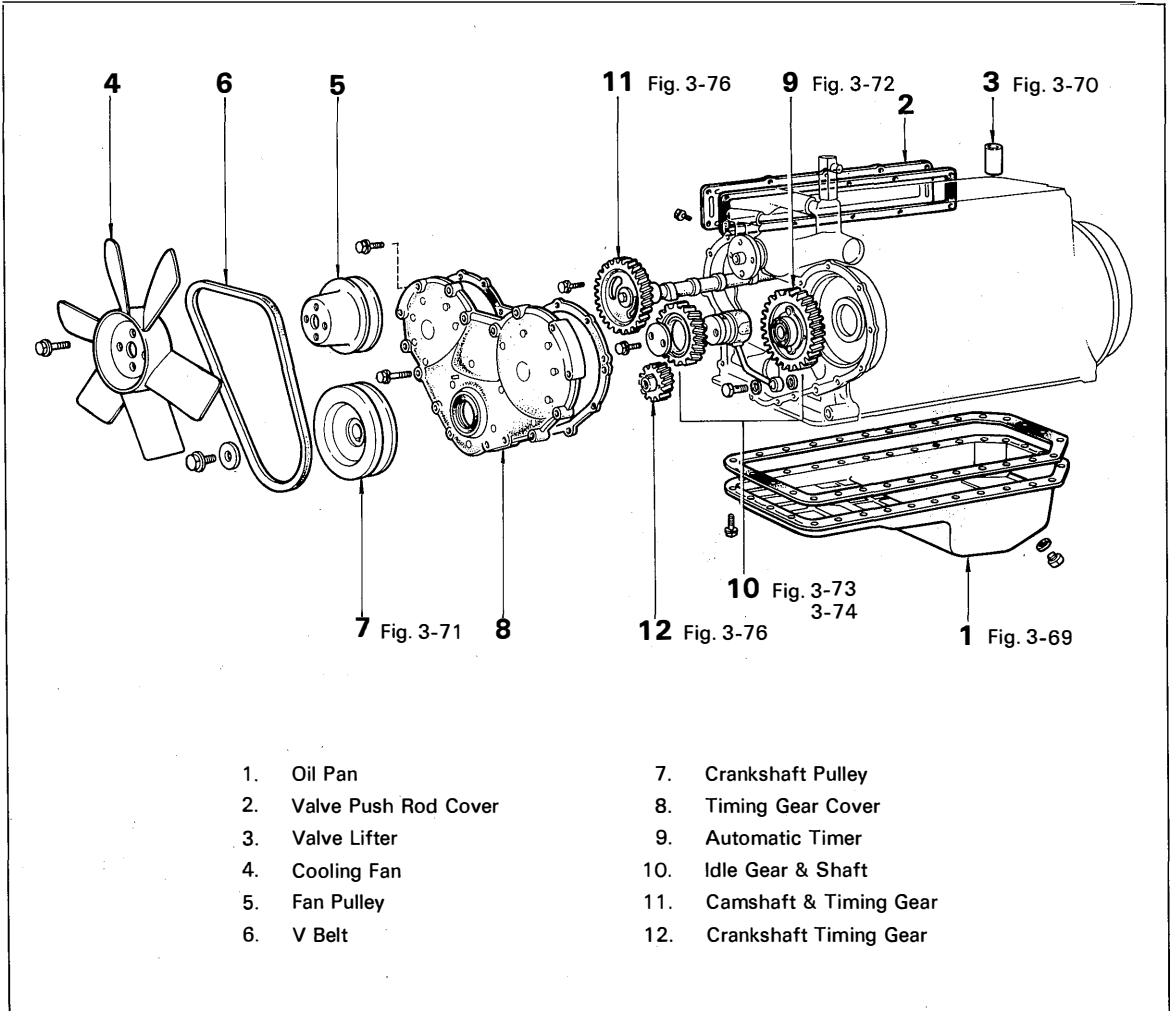
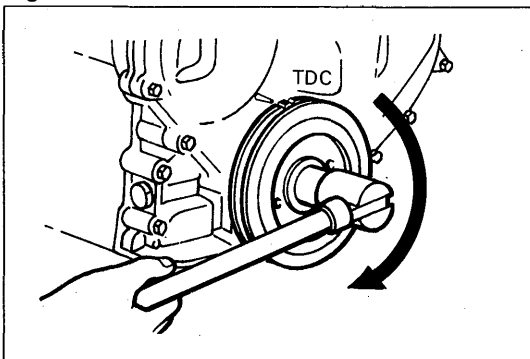
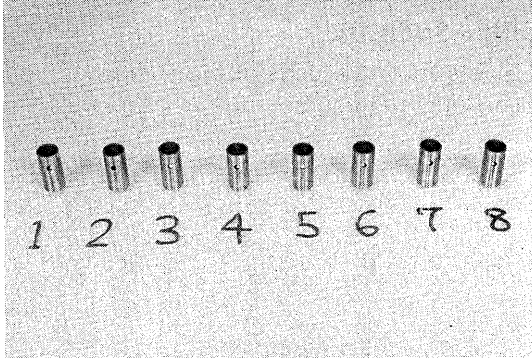

Fig. 3-69



Before starting work, set No. 1 cylinder piston to TDC/compression.

Fig. 3-70



Keep the valve lifters in correct order.

Fig. 3-71

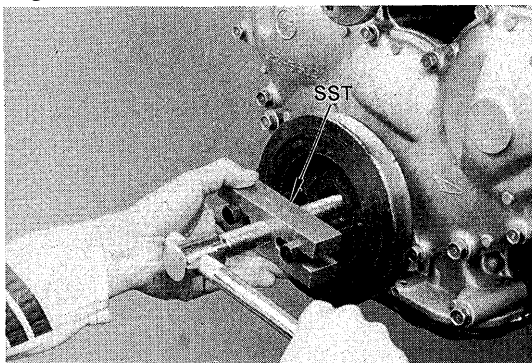

Pull out the crankshaft pulley with SST.
SST [09213-60016]

Fig. 3-72

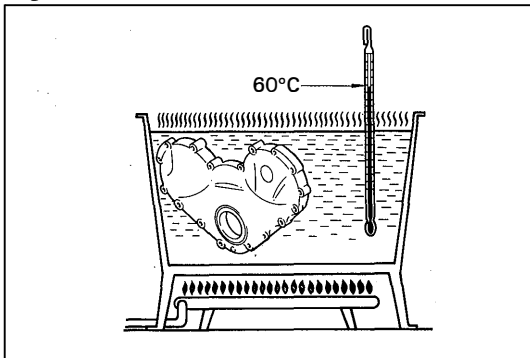

Remove the automatic timer from the timing gear cover after heating the cover to about 60°C (140°F).

—Note—

For disassembly and assembly of the automatic timer, refer to the FUEL SYSTEM section.

Fig. 3-73

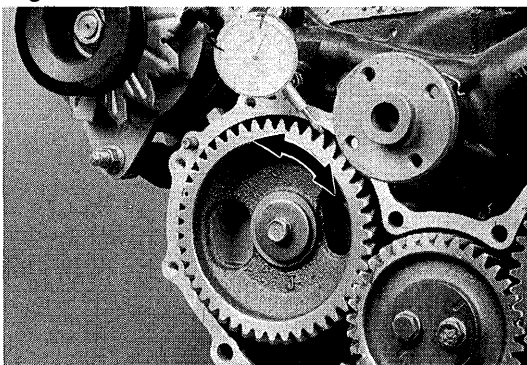

Install the automatic timer to the injection pump spline shaft and measure the timing gear backlashes.

Gear backlash:

Idle gear to cam gear, timer drive gear

STD 0.06 – 0.09 mm
(0.0024 – 0.0035 in.)

Limit 0.3 mm (0.012 in.)

Crankshaft to idle gear

STD 0.06 – 0.10 mm
(0.0024 – 0.0039 in.)

Limit 0.3 mm (0.012 in.)

Fig. 3-74

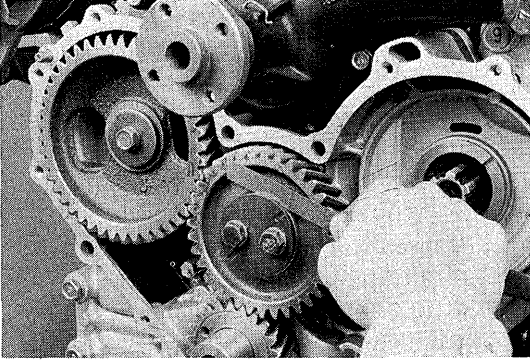

Measure the idle gear thrust clearance.

Thrust clearance:

STD 0.08 – 0.20 mm
(0.0031 – 0.0079 in.)

Limit 0.3 mm
(0.012 in.)

Fig. 3-75

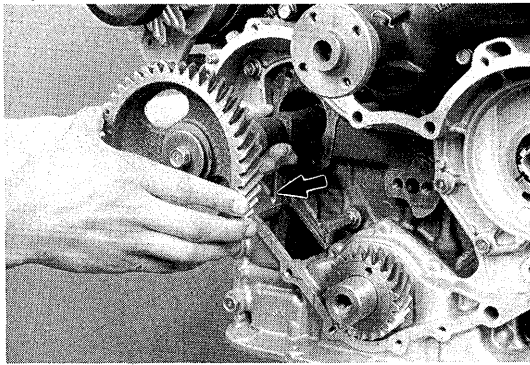

Pull out the camshaft, using care not to damage the camshaft bearings.

Fig. 3-76

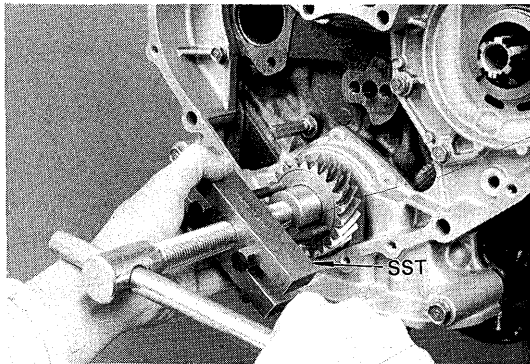

Pull out the crankshaft timing gear with SST.
SST [09213-60016]

Fig. 3-77

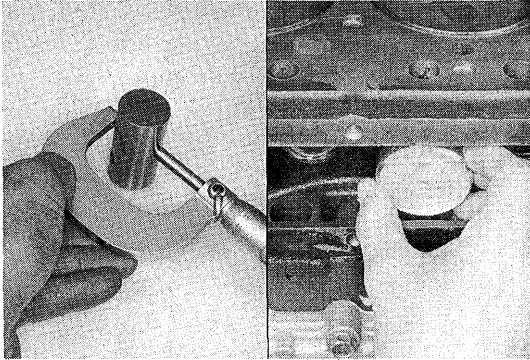
**INSPECTION & REPAIR****Valve Lifter**

Check the lifters and lifter bores for wear or damage.

Measure the oil clearance.

Valve lifter outer diameter:

23.972 – 23.985 mm

(0.9438 – 0.9443 in.)

Valve lifter bore diameter:

24.00 – 24.02 mm

(0.9449 – 0.9457 in.)

Oil clearance:

STD 0.02 – 0.05 mm

(0.0008 – 0.0020 in.)

Limit 0.1 mm (0.004 in.)

Fig. 3-78

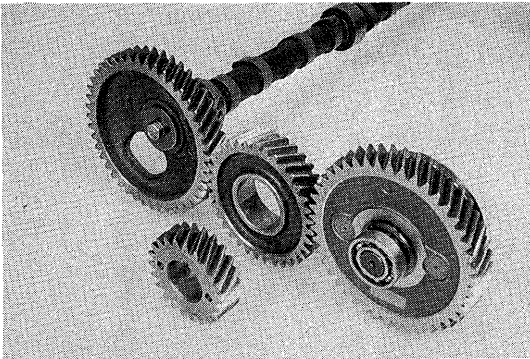
**Timing Gears**

Check for cracks, wear and chipped teeth.

If damaged, replace the gear along with its mate.

Fig. 3-79

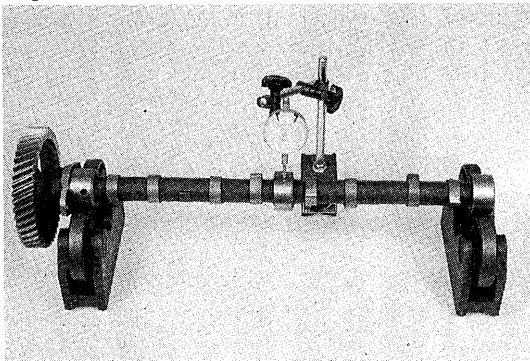
**Camshaft**

1. Check for straightness and for wear or damage.
2. Measure the runout.

Circle runout:

Limit 0.04 mm

(0.0016 in.)

Fig. 3-80

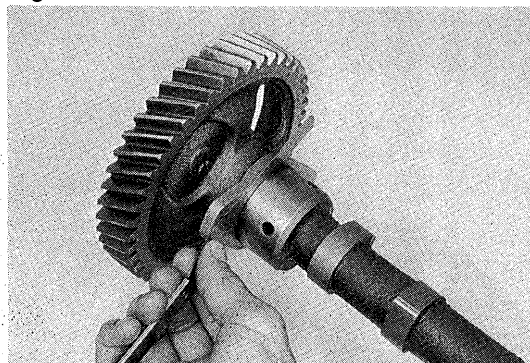

3. Measure the camshaft thrust clearance.

Thrust clearance:

STD 0.06 – 0.13 mm

(0.0024 – 0.0051 in.)

Limit 0.3 mm

(0.012 in.)

Fig. 3-81

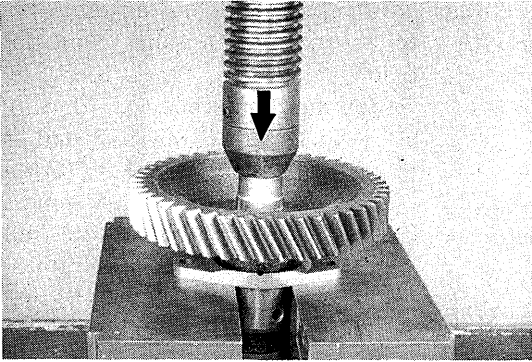

4. Replace the thrust plate if the thrust clearance exceeds the limit.
- (1) Using a press and 19 mm socket wrench, press out the timing gear from the camshaft.

Fig. 3-82

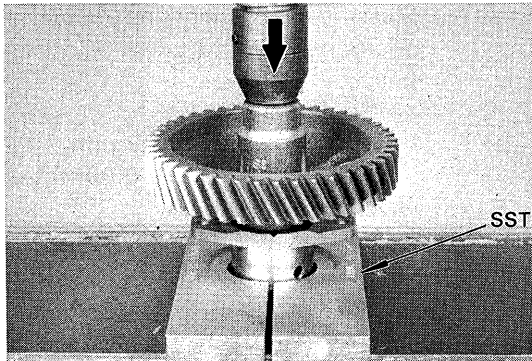

- (2) Using a press, 29 mm socket wrench and SST, press in the timing gear. SST [09527-21011]

Fig. 3-83

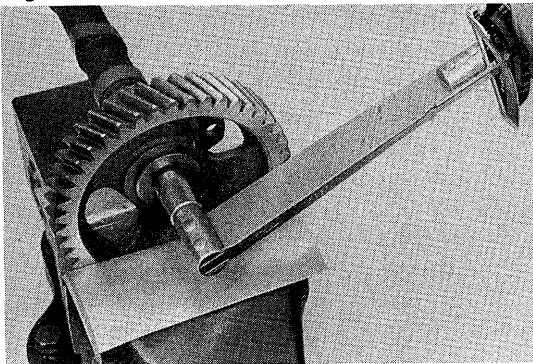

- (3) Tighten the retaining bolt.
Tightening torque:
3.0 – 4.5 kg-m
(22 – 32 ft-lb)

—Note—

Apply a light coat of engine oil on the bolt threads and under the bolt head before installing.

Fig. 3-84

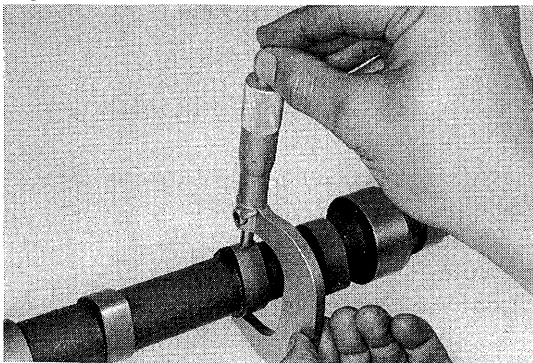

5. Measure the cam height.

Cam height:

STD	39.47 – 39.56 mm (1.5539 – 1.5575 in.)
Limit	39.0 mm (1.535 in.)

Fig. 3-85

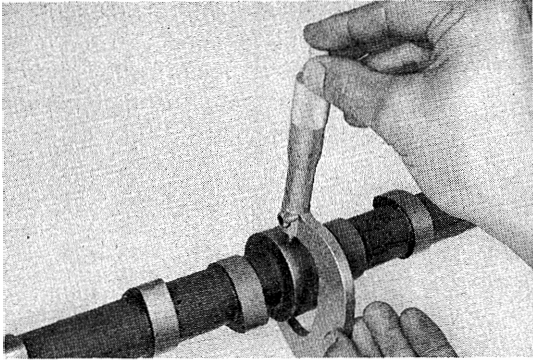

5. Measure the journal oil clearance.
 (1) Measure the camshaft journal diameter.

Journal diameter:

No.1	47.16 – 47.18 mm (1.8567 – 1.8575 in.)
No.2	46.96 – 46.98 mm (1.8488 – 1.8496 in.)
No.3	46.76 – 46.78 mm (1.8409 – 1.8417 in.)

Fig. 3-86

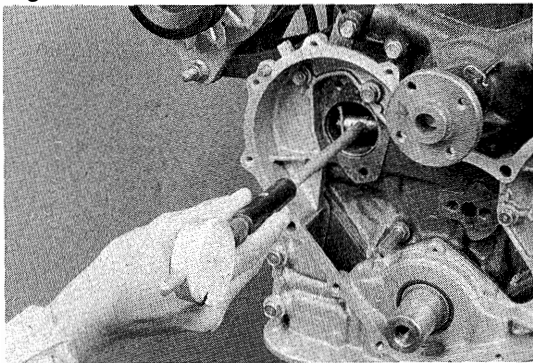

- (2) Measure the bearing inner diameter, referring to CYLINDER BLOCK section.

Oil clearance:

STD	0.03 – 0.07 mm (0.0012 – 0.0028 in.)
Limit	0.1 mm (0.004 in.)

Fig. 3-87

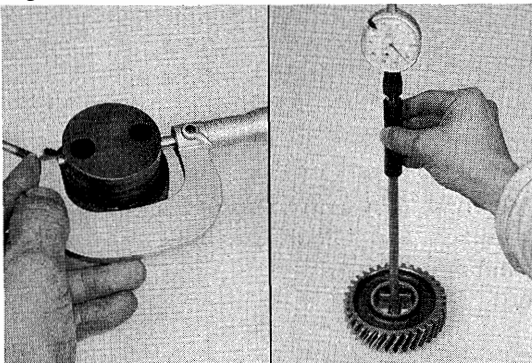
**Idle Gear**

Measure the idle gear oil clearance.

Idle gear shaft diameter:

44.94 – 44.96 mm
(1.7693 – 1.7701 in.)

Idle gear bore:

45.00 – 45.03 mm
(1.7717 – 1.7728 in.)

Oil clearance:

STD 0.04 – 0.09 mm
(0.0016 – 0.0035 in.)

Limit 0.3 mm (0.012 in.)

Fig. 3-88

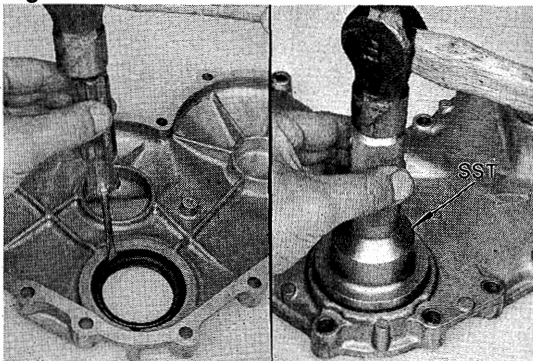
**Crankshaft Front Oil Seal**

1. Check for wear or damage.
2. Replace the oil seal with SST.
 - (1) Remove the oil seal with a screwdriver.
 - (2) Install a new oil seal with SST. SST [09223-46011]

—Note—

Coat the oil seal lip with MP grease.

ASSEMBLY

Assemble the parts in the numerical order shown in the figure.

Fig. 3-89

—Note—

1. Thoroughly clean all parts to be assembled.
2. Apply clean engine oil to all sliding and rotating surfaces of the parts before assembly.

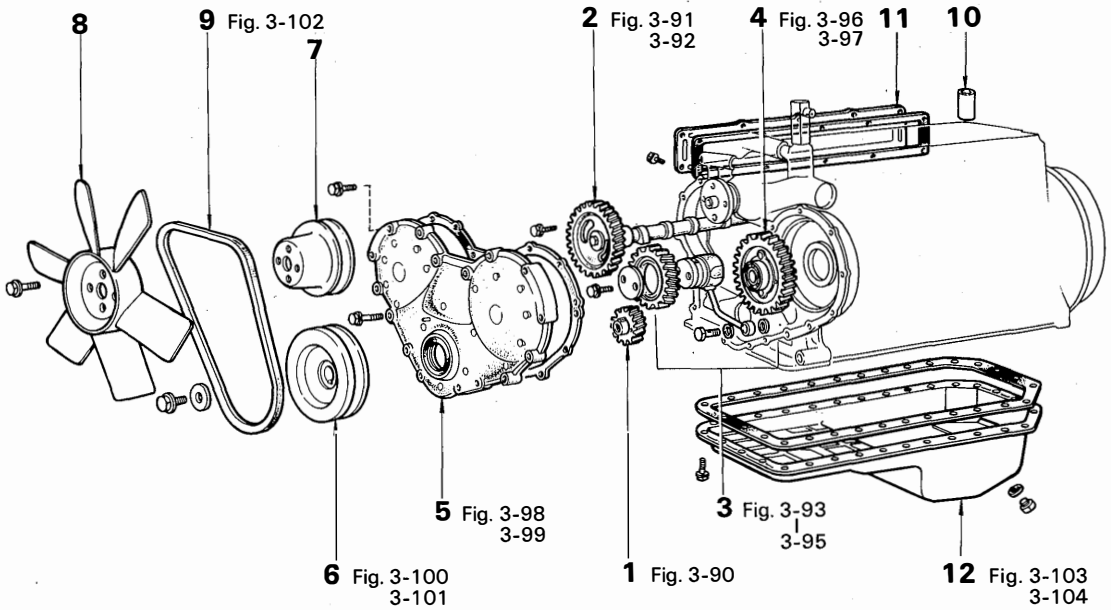

- | | |
|---------------------------|--------------------------|
| 1. Crankshaft Timing Gear | 7. Fan Pulley |
| 2. Camshaft & Timing Gear | 8. Cooling Fan |
| 3. Idle Gear & Shaft | 9. V Belt |
| 4. Automatic Timer | 10. Valve Lifter |
| 5. Timing Gear Cover | 11. Valve Push Rod Cover |
| 6. Crankshaft Pulley | 12. Oil Pan |

Fig. 3-90

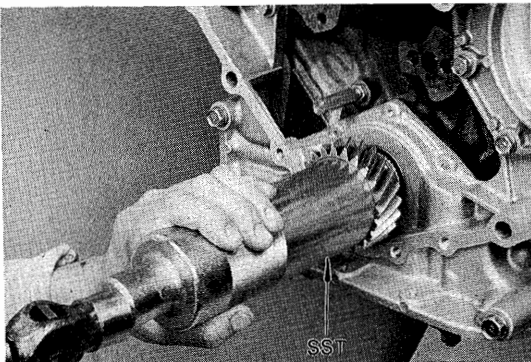

Drive in the crankshaft timing gear with SST. SST [09316-60010]

Fig. 3-91

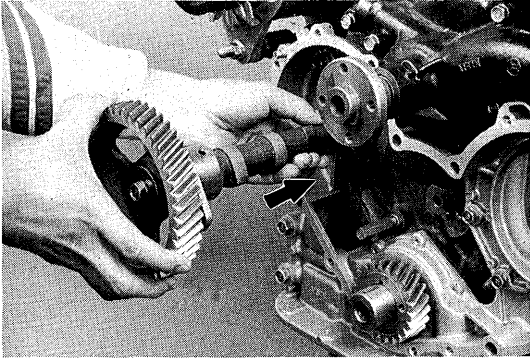

Insert the camshaft, using care not to damage the camshaft bearings.

Fig. 3-92

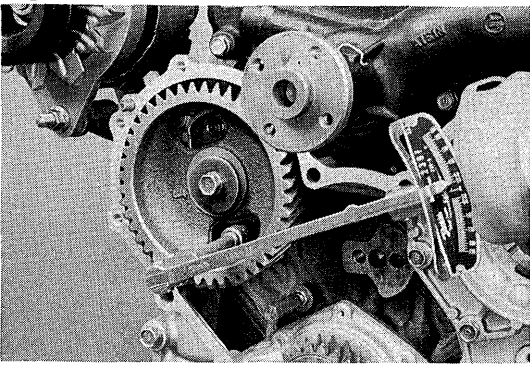

Tighten the camshaft thrust plate.

**Tightening torque: 1.5 – 2.2 kg-m
(11 – 15 ft-lb)**

Fig. 3-93

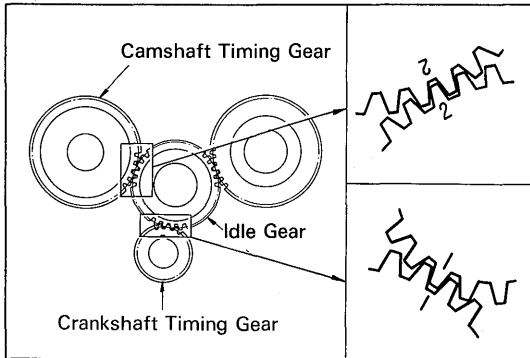

Set the idle gear aligning marks 1 and 2 respectively against crankshaft gear mark 1 and camshaft gear mark 2.

Fig. 3-94

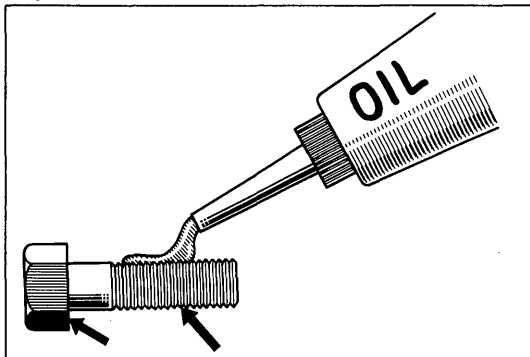

Apply a light coat of engine oil on the bolt threads and under the bolt head before installing.

Fig. 3-95

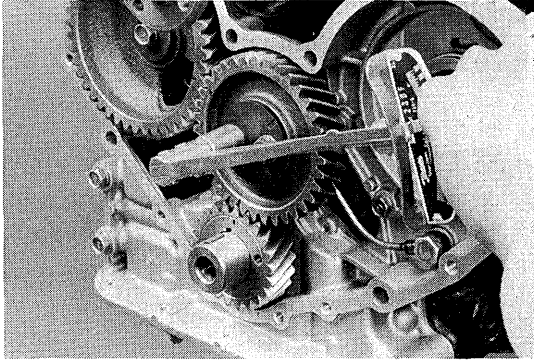

Tighten the idle gear and shaft.

**Tightening torque: 4.0 – 5.5 kg-m
(29 – 39 ft-lb)**

Fig. 3-96

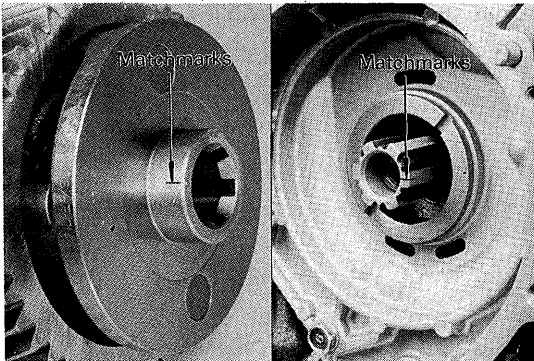

When installing the automatic timer, align the matchmarks on injection pump spline shaft and timer drive shaft.

–Note–

Coat the splines and bearing with MP grease.

Fig. 3-97

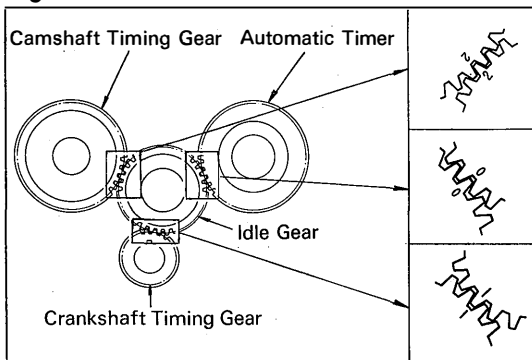

Align the idle gear 0 mark against the timer drive gear 0 mark.

Fig. 3-98

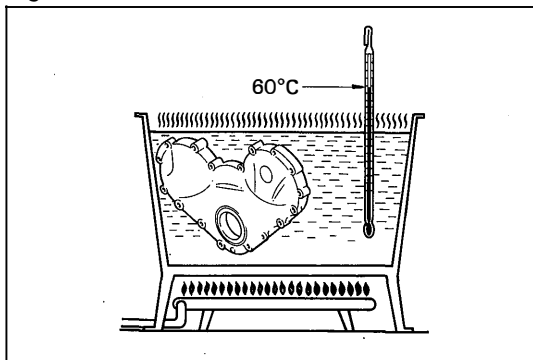

Heat the timing gear cover to about 60°C (140°F) before installing.

Fig. 3-99

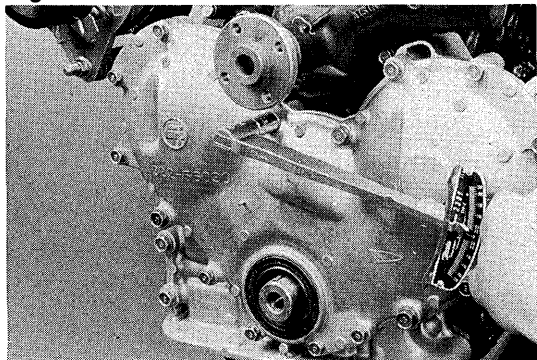

Tighten the timing gear cover.

Tightening torque:

8 mm bolt 1.5 – 2.2 kg-m
(11 – 15 ft-lb)

10 mm bolt 3.0 – 4.5 kg-m
(22 – 32 ft-lb)

Fig. 3-100

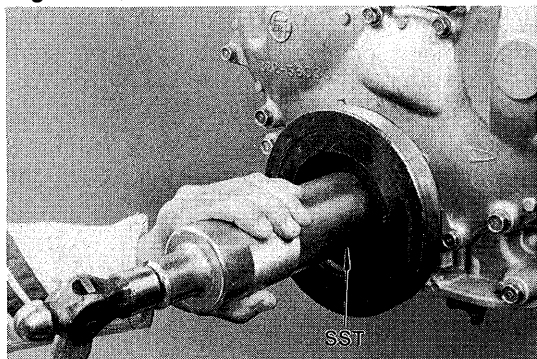

Drive in the crankshaft pulley with SST.
SST [09316-60010]

Fig. 3-101

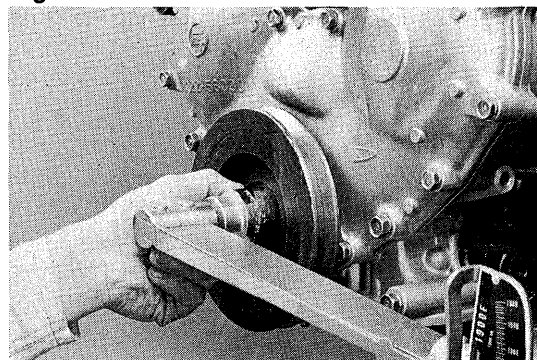

Tighten the retaining bolt.

Tightening torque: 20.0 – 24.0 kg-m
(145 – 173 ft-lb)

—Note—

Apply a light coat of engine oil on the bolt threads and under the bolt head before installing.

Fig. 3-102

SEE
ENGINE TUNE-UP
SECTION
Fig. 2-7 & 2-8

Adjust drive belt tension.

Fig. 3-103

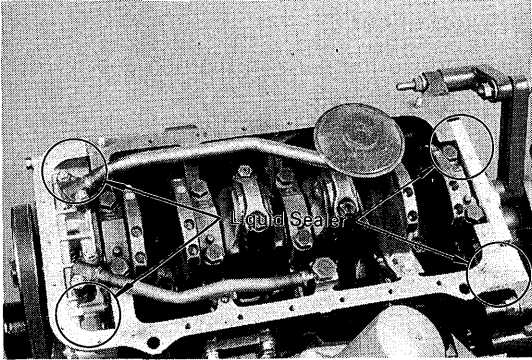

Apply liquid sealer to the cylinder block and gear cover at the areas shown in the figure.

Fig. 3-104

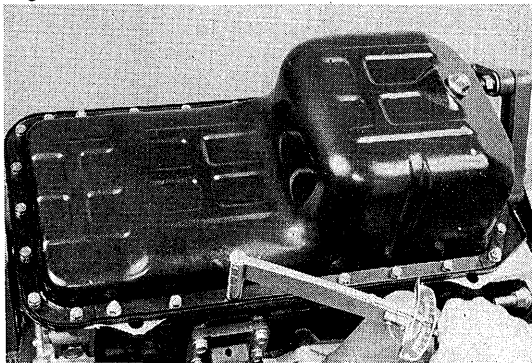

Install the oil pan.

Tightening torque: 0.7 – 1.3 kg-m
(61 – 112 in.-lb)

CYLINDER BLOCK DISASSEMBLY

Disassemble the parts in the numerical order shown in the figure.

Fig. 3-105

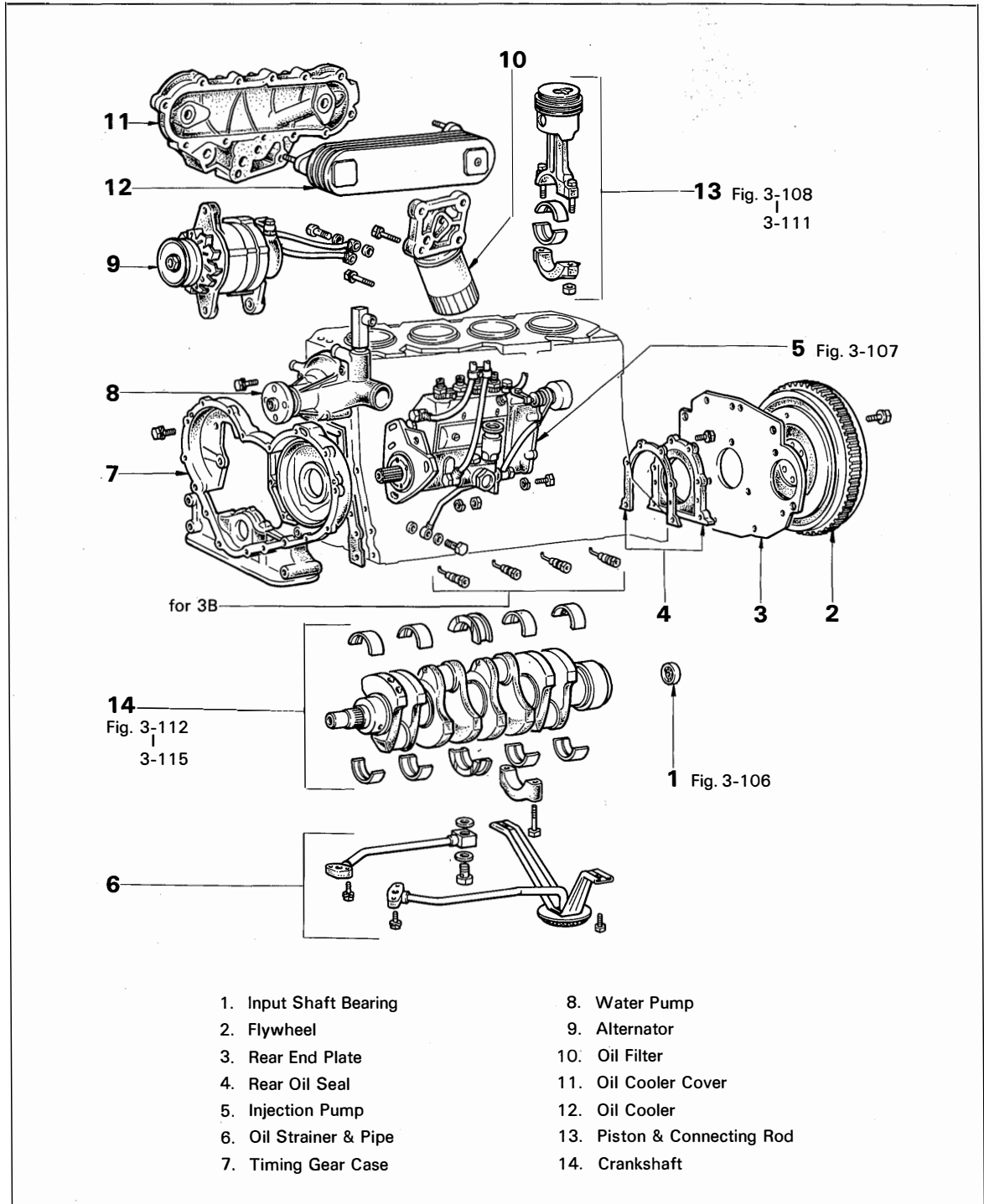

- | | |
|------------------------|-----------------------------|
| 1. Input Shaft Bearing | 8. Water Pump |
| 2. Flywheel | 9. Alternator |
| 3. Rear End Plate | 10. Oil Filter |
| 4. Rear Oil Seal | 11. Oil Cooler Cover |
| 5. Injection Pump | 12. Oil Cooler |
| 6. Oil Strainer & Pipe | 13. Piston & Connecting Rod |
| 7. Timing Gear Case | 14. Crankshaft |

Fig. 3-106

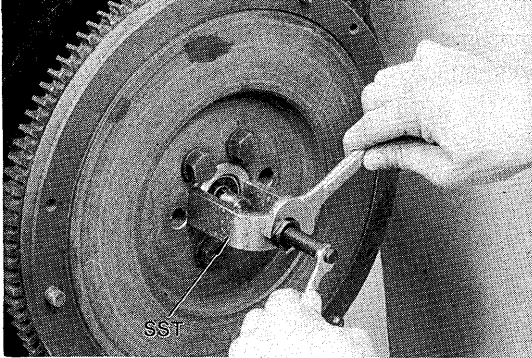

Remove the input shaft bearing with SST.
SST [09303-35010]

Fig. 3-107

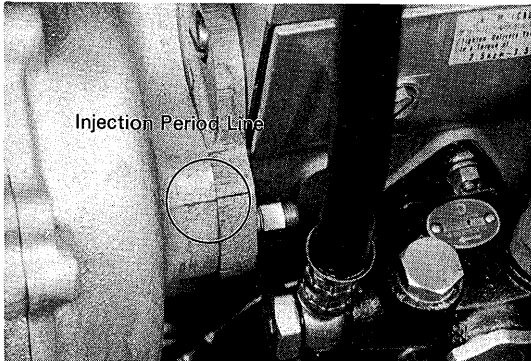

Check the position of injection period line
before removing the injection pump.

Fig. 3-108

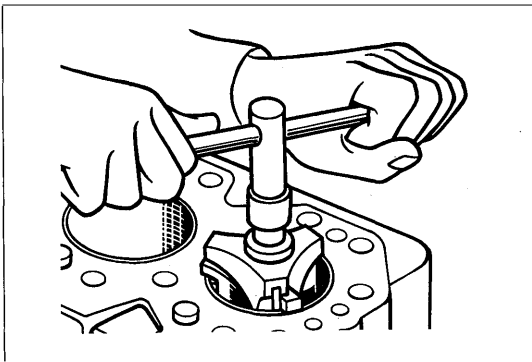

—Note—

If carbon has accumulated on the top of the
bore, remove it with a ridge reamer before
removing the piston.

Fig. 3-109

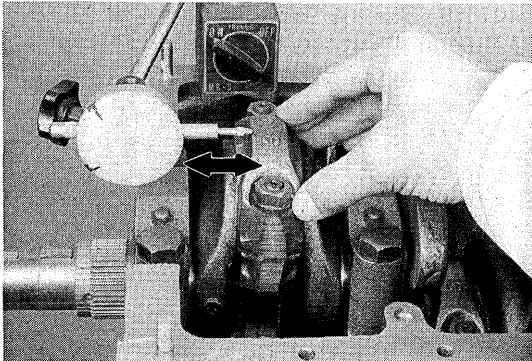

Measure the connecting rod thrust clearance.
If it exceeds the limit, replace the connecting
rod.

Thrust clearance:

STD 0.08 – 0.20 mm
(0.0031 – 0.0079 in.)

Limit 0.3 mm
(0.012 in.)

Fig. 3-110

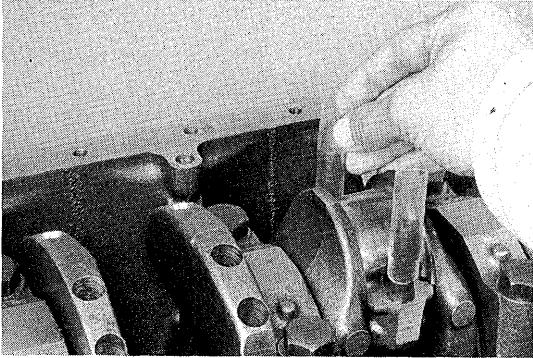

Cover the connecting rod bolts with short hoses to protect the crankshaft pins from damage.

Fig. 3-111

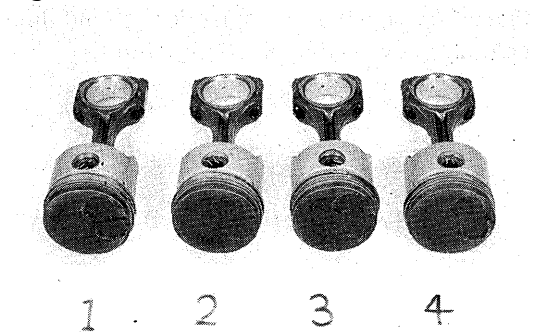

Keep the pistons and connecting rod caps in correct order.

Fig. 3-112

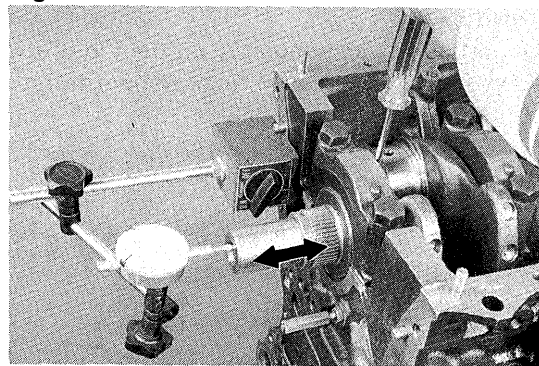

Measure the crankshaft thrust clearance. If it exceeds the limit, replace the bearings as a set.

Thrust clearance:

STD 0.07 – 0.18 mm
(0.0028 – 0.0071 in.)

Limit 0.3 mm
(0.012 in.)

U/S bearing type 0.25, 0.50, 1.00

Fig. 3-113

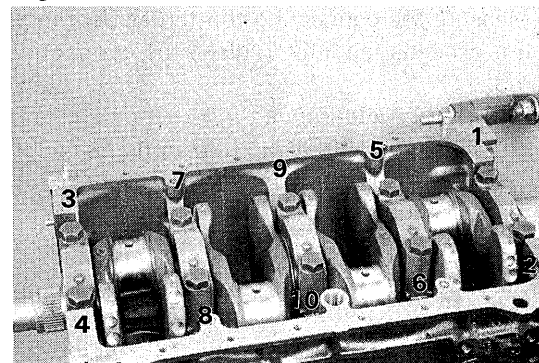

Loosen each crankshaft bearing bolt a little at a time in the sequence shown in the figure.

Fig. 3-114

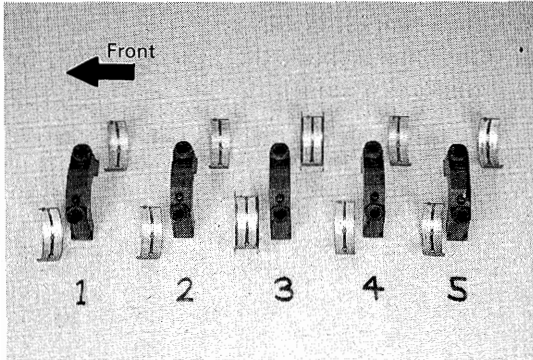

Keep the crankshaft bearings and caps in correct order.

Fig. 3-115

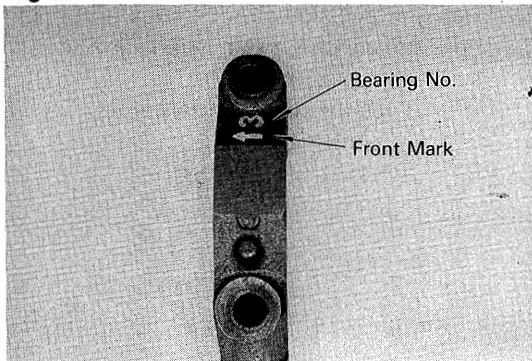

—Note—

The number and front side of each bearing should be marked.

Fig. 3-116

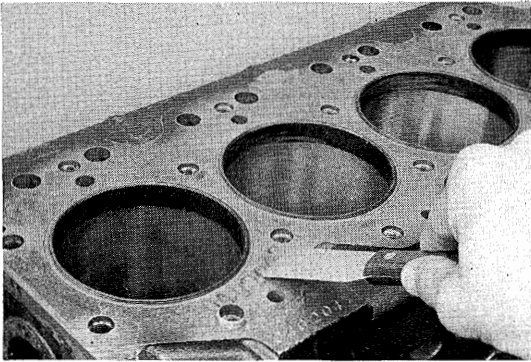
**INSPECTION & REPAIR****Cylinder Block & Liner**

1. Clean and check the cylinder block for cracks or scoring.

Fig. 3-117

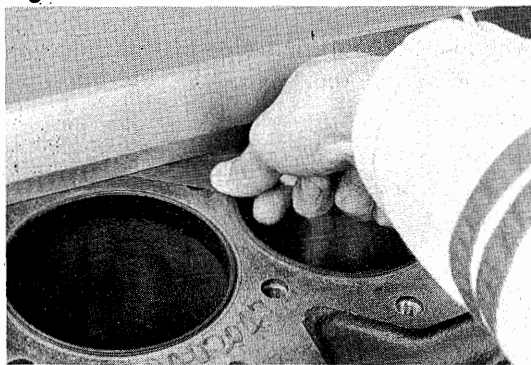

2. Using a precision straight edge and thickness gauge, check the cylinder block top-side surface for warpage.

Topside surface warpage:

**Limit 0.2 mm
(0.008 in.)**

Fig. 3-118

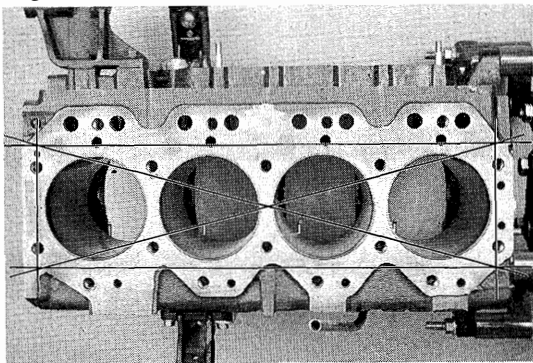

3. Check for warp along the indicated lines.

Fig. 3-119

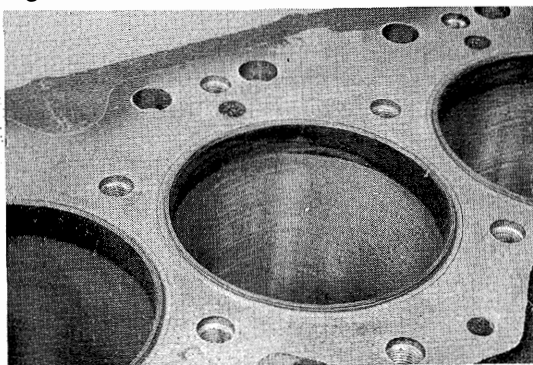

4. Visually check the cylinder for vertical scratches. If there are deep scratches, the cylinder liner must be rebored or replaced. Refer to Fig. 3-123 to 3-132.

—Note—

When reboring the liner, rebore all cylinders to the same size.

Fig. 3-120

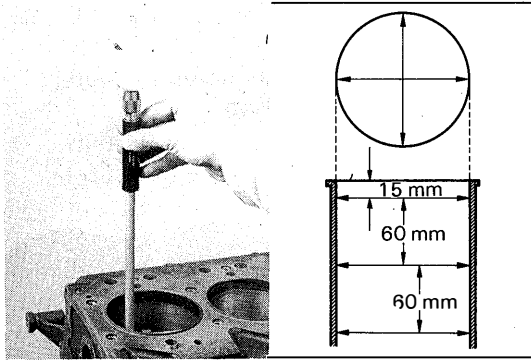

Fig. 3-121

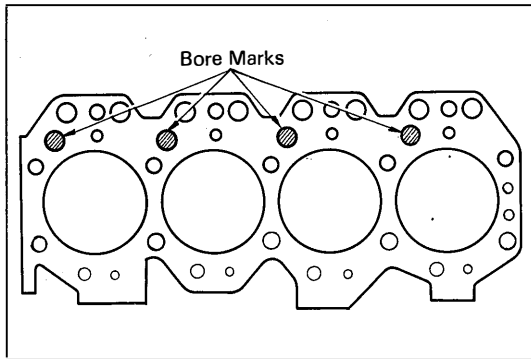

Fig. 3-122

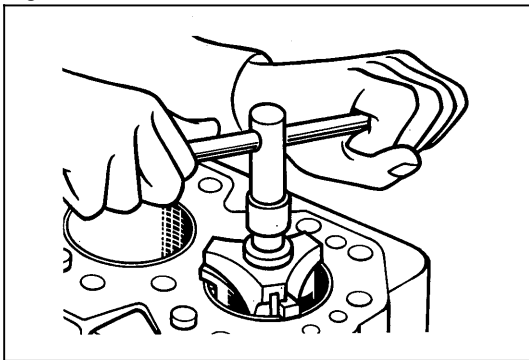
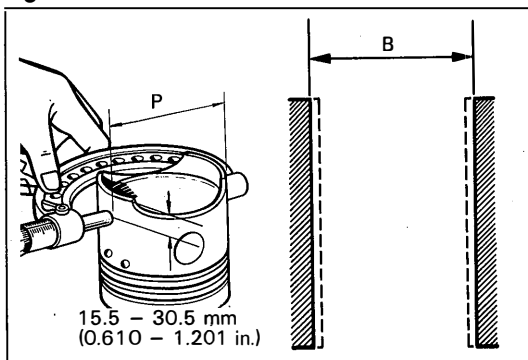

Fig. 3-123



5. Measure the cylinder bore at the top, middle and bottom as shown in the figure. If wear exceeds the limit, the liner must be rebored or replaced. Refer to Fig. 3-123 to 3-132.

Wear:

Limit 0.3 mm (0.012 in.)

Mark	Size mm (in.)		
	B	2B	3B
1	95.00-95.01 (3.7402-3.7405)	98.00-98.01 (3.8583-3.8587)	102.00-102.01 (4.0157-4.0161)
2	95.01-95.02 (3.7405-3.7409)	98.01-98.02 (3.8587-3.8590)	102.01-102.02 (4.0161-4.0165)
3	95.02-95.03 (3.7409-3.7413)	98.02-98.03 (3.8590-3.8594)	102.02-102.03 (4.0165-4.0169)



-Note-

The bore marks are stamped on cylinder block top surface as shown in the figure.

6. If wear is less than 0.3 mm (0.012 in.), machine the piston ring ridge at the top of the bore with a ridge reamer.



7. If wear exceeds the limit, rebore the cylinder liner. (for B engine)

- (1) Use following equation to determine the reboring diameter.

$$B = P + C - H$$

B: Reboring diameter

P: O/S piston diameter

C: Piston oil clearance

0.11 - 0.13 mm
(0.0043 - 0.0051 in.)

H: Honing allowance

Less than 0.02 mm
(0.0008 in.)

Fig. 3-124

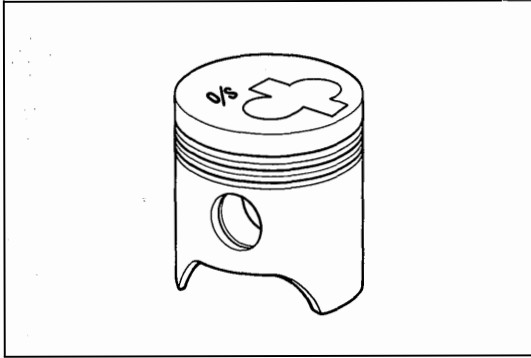

- (2) Use oversize piston after reboring the liner.

Oversize piston diameter:
O/S 1.00
95.88 – 95.91 mm
(3.7748 – 3.7760 in.)

–Note–

If wear is excessive, replace the cylinder liner.

Fig. 3-125

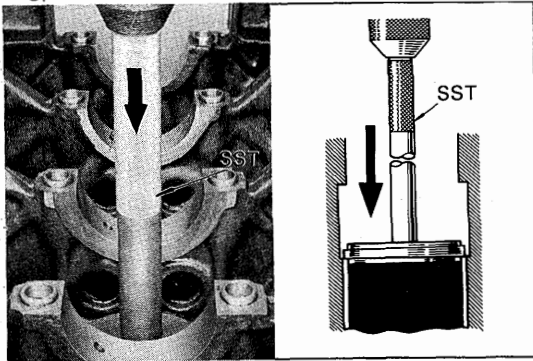

- 8. If wear exceeds the limit, replace the cylinder liner with SST.

For B & 2B

- (1) Press out the cylinder liner with SST. SST [09218-56020]

Fig. 3-126

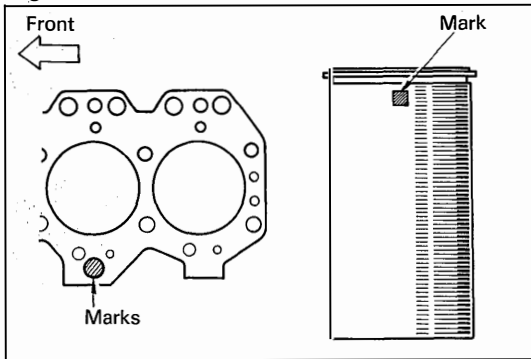

- (2) Select the liner having the same mark as the cylinder block; A or B.

Fig. 3-127

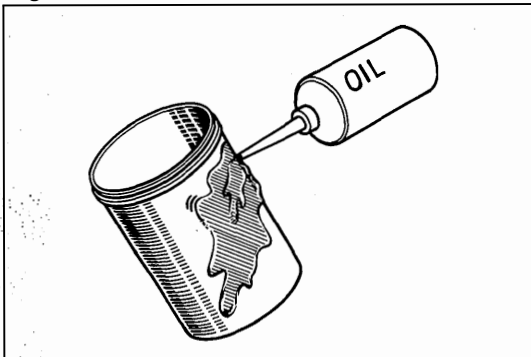

- (3) Lubricate the outside surface of the cylinder liner with engine oil before installing.

Fig. 3-128

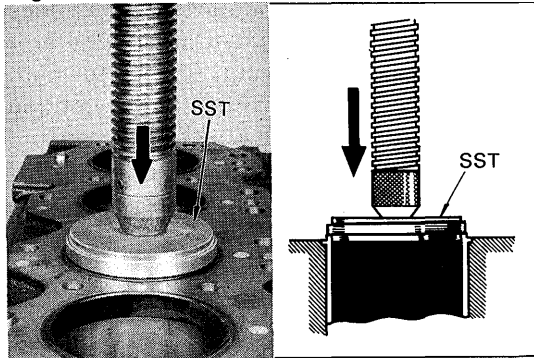

- (4) Press in the cylinder liner with SST.
SST [09218-56020]

**Pressing force: 2,500 kg
(5,500 lb)**

—Note—

After pressing in the liner, rebore and hone the liner bore to fit a standard piston.

Fig. 3-129

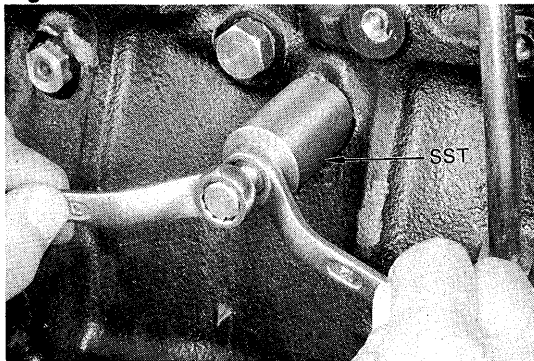

For 3B

- (1) Pull out the oil nozzle from the cylinder block with SST.
SST [09219-56010]

—Note—

- 1. Use care not to damage the nozzle point.**
- 2. Check the nozzle for clogging and, if necessary, replace it with new one.**

Fig. 3-130

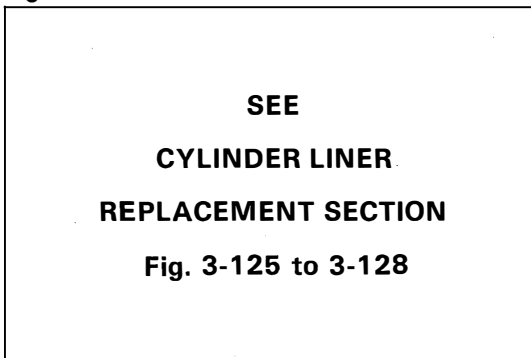

- (2) Replace the cylinder liner with SST in the same manner as for B and 2B engines.
SST [09218-56030]

Fig. 3-131

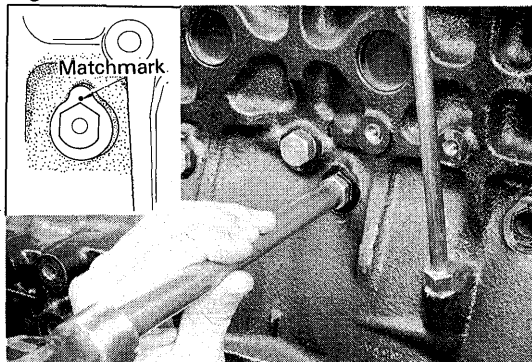

- (3) Drive in the oil nozzle facing its head point toward the matchmark of the cylinder block as shown in the figure.

—Note—

- 1. When installing the oil nozzle, be sure to replace the O ring with new one.**

Fig. 3-132

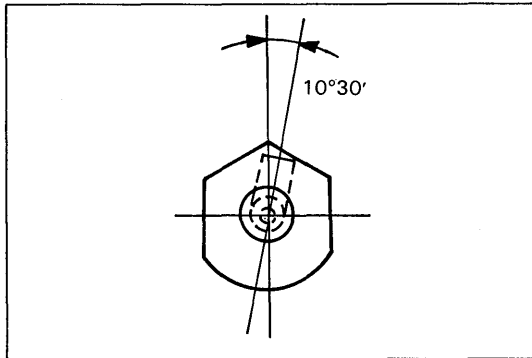

2. Make sure that the nozzle point faces the direction indicated in the figure. If not, the piston may be deformed, resulting in excessive oil consumption and possibly a stuck piston.

Fig. 3-133

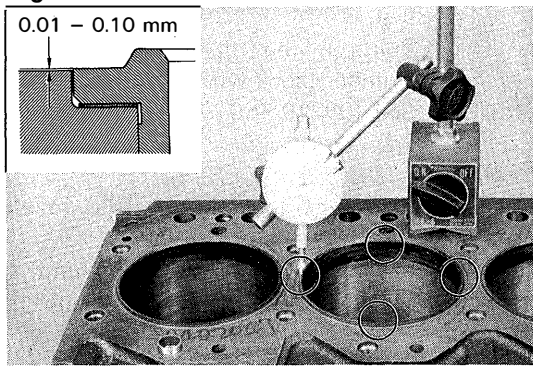

9. After replacing the cylinder liner, measure the protrusion of liner above the cylinder block top surface at four positions.

Protrusion: 0.01 – 0.10 mm
(0.0004 – 0.0039 in.)

Fig. 3-134

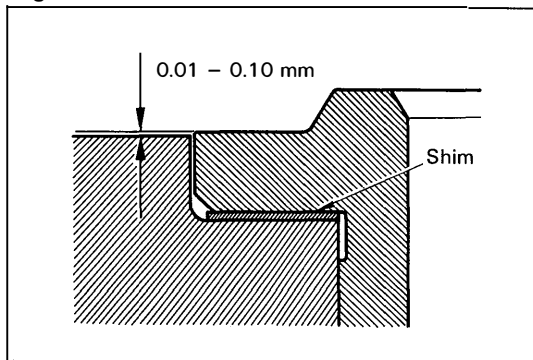

10. Adjust the protrusion of cylinder liner with the cylinder liner shims.

Cylinder liner shim thickness:
0.05, 0.10 mm
(0.0020, 0.0039 in.)

Fig. 3-135



Piston Pin & Connecting Rod

1. Check pin fit by rocking the piston at right angle to the pin. If any movement is felt, replace the piston and pin.

Fig. 3-136

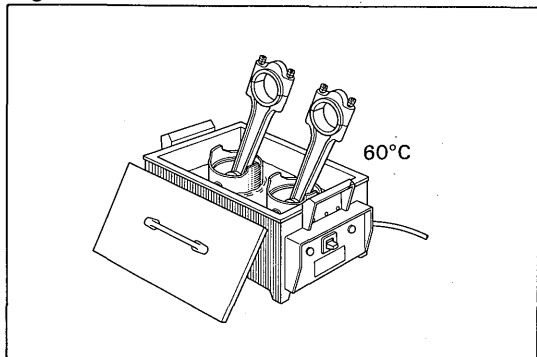

- Heat the piston in a piston heater to about 60°C (140°F) before removing the piston pin.

Fig. 3-137



- Normally, the pin can be pushed out by hand, but if difficult, drive it out with a brass bar or such.

Fig. 3-138

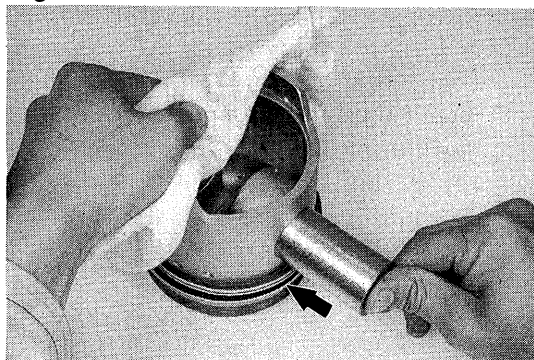

- Check piston pin fitness. Heat the piston to about 60°C (140°F) and coat the piston pin with engine oil. It should be possible to push the pin into the piston hole with your thumb.

Fig. 3-139

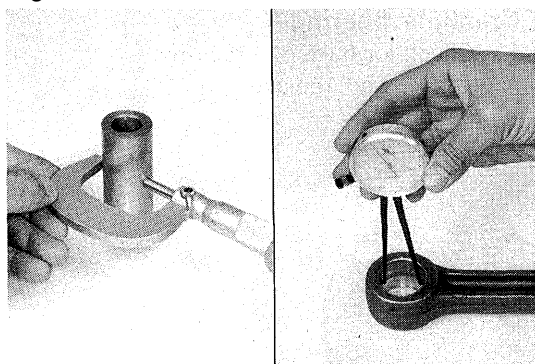

- Measure the oil clearance between the bushing and piston pin.

Bushing oil clearance:

STD	0.004 – 0.014 mm (0.0002 – 0.0006 in.)
Limit	0.05 mm (0.0020 in.)

Fig. 3-140

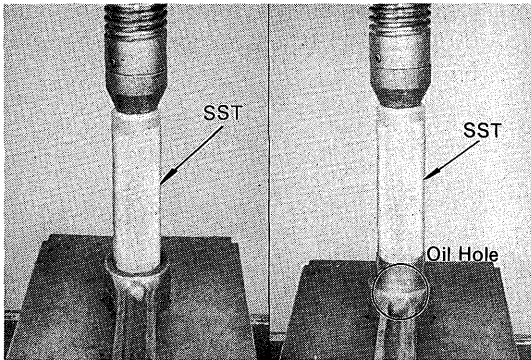

6. Replace the bushing with SST.
SST [09222-66010]



— Note —

Align the oil hole of the bushing with that of the connecting rod.

Fig. 3-141

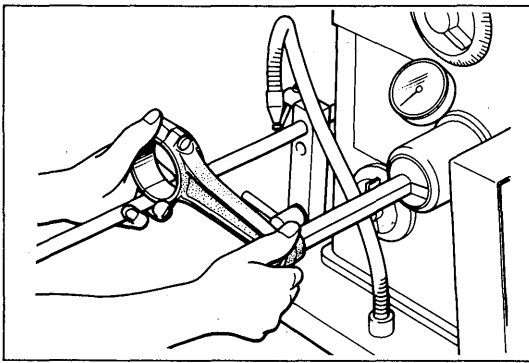

7. After installing the bushing, finish the bushing bore with a pin hole grinder.

Fig. 3-142

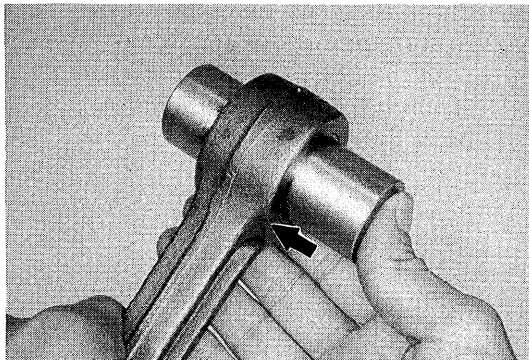

8. Check the fitness between the bushing and pin.
Coat the piston pin with engine oil. At room temperature, the pin can be pushed in with your thumb.

Fig. 3-143

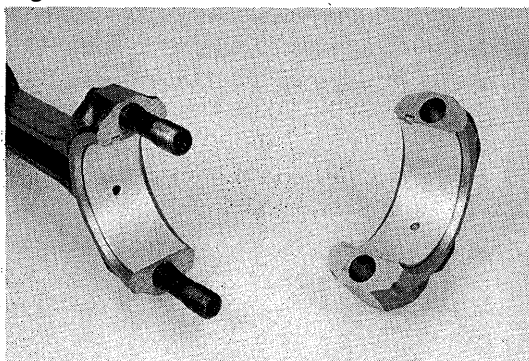

Crankpin Bearing

1. Check for flaking or scoring.
If damaged, replace.

Fig. 3-144

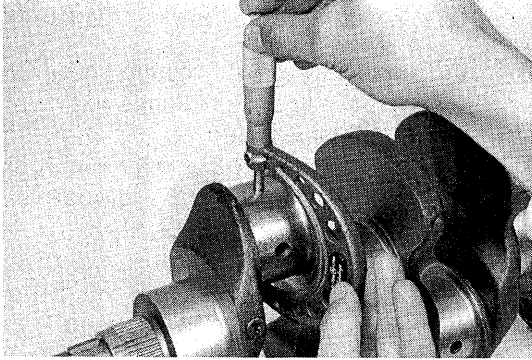

2. Measure the crankpin diameter.
If wear is excessive, the crankshaft must be reground or replaced.

Crankpin diameter:**STD**

B & 2B 58.98 – 59.00 mm
(2.3220 – 2.3228 in.)

3B 60.98 – 61.00 mm
(2.4008 – 2.4016 in.)

Fig. 3-145

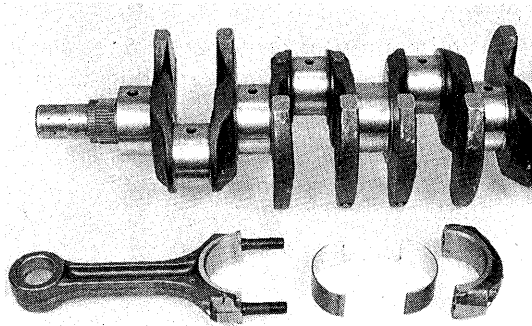

3. Measure the crankpin oil clearance.
(1) Clean the crankshaft pin, connecting rod, cap and bearings.

Fig. 3-146

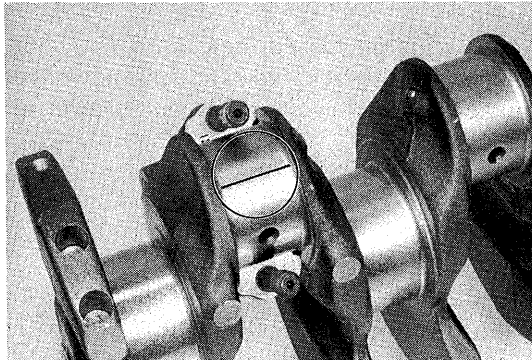

- (2) Lay a strip of plastigage across the pin.

Fig. 3-147

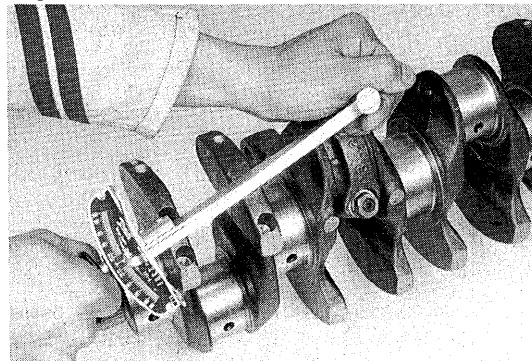

- (3) Tighten the cap nuts to specified torque.

Tightening torque:

B & 2B 6.5 – 7.5 kg-m
(48 – 54 ft-lb)

3B 8.5 – 9.5 kg-m
(62 – 68 ft-lb)

—Note—

Do not turn the connecting rod or crankshaft.

Fig. 3-148

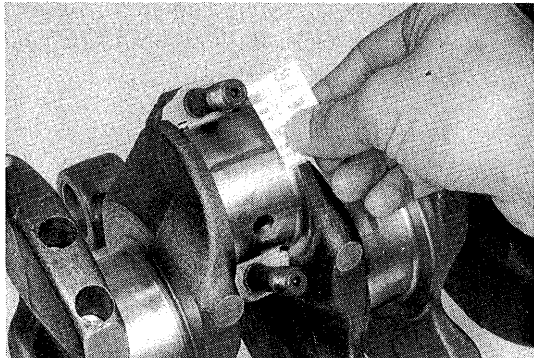

- (4) Measure the plastigage at its widest point.

If clearance is not within specification, replace the bearings.

Oil clearance:

STD 0.03 – 0.07 mm
(0.0012 – 0.0028 in.)

Limit 0.1 mm
(0.004 in.)

U/S bearing type
0.25, 0.50, 1.00

Fig. 3-149

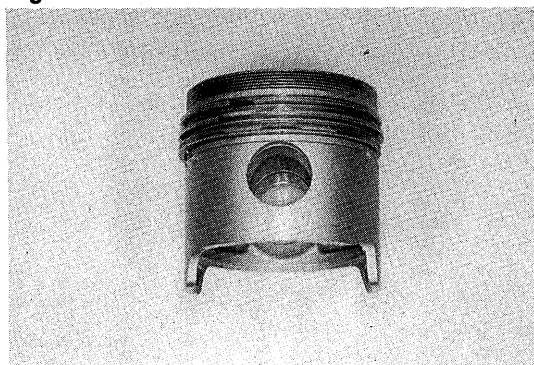

Piston

1. Check for wear or damage, especially in the piston ring grooves and ring lands.

Fig. 3-150

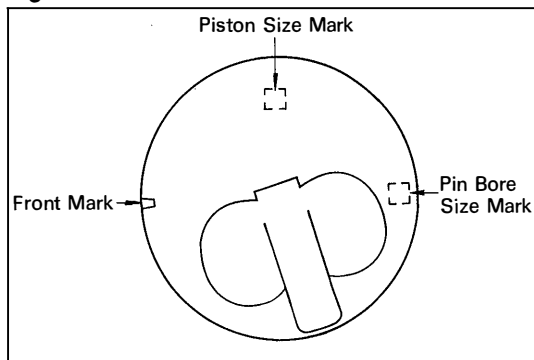

—Note—

At the piston top surface there is a mark indicating the front side and stamped codes indicating piston diameter and piston pin bore.

2. Check the piston clearance.
 - (1) Measure the piston diameter in the thrust direction about 15.5 – 30.5 mm (0.610 – 1.201 in.) up from skirt bottom edge.

This measurement must be made at room temperature, 20°C (68°F).

Fig. 3-151

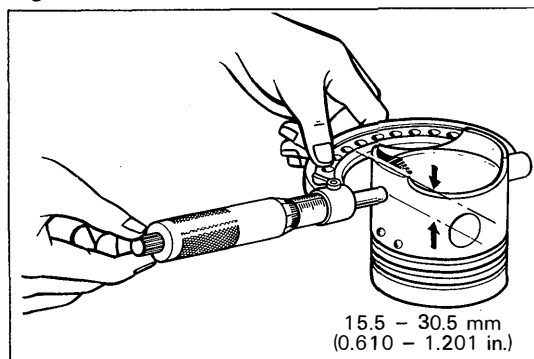

Mark	Piston size mm (in.)		
	B	2B	3B
1	94.88-94.89 (3.7354-3.7358)	97.88-97.89 (3.8535-3.8539)	101.90-101.91 (4.0118-4.0122)
2	94.89-94.90 (3.7358-3.7362)	97.89-97.90 (3.8539-3.8543)	101.91-101.92 (4.0122-4.0126)
3	94.90-94.91 (3.7362-3.7366)	97.90-97.91 (3.8543-3.8547)	101.92-101.93 (4.0126-4.0130)

15.5 – 30.5 mm
(0.610 – 1.201 in.)

Fig. 3-152

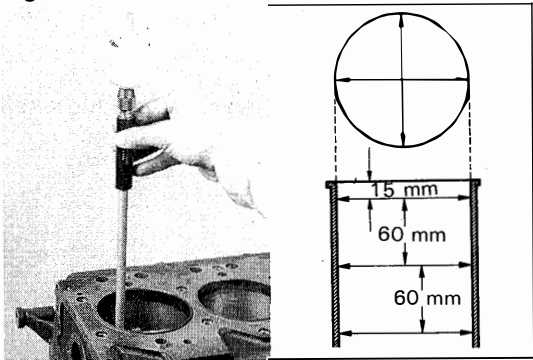

- (2) Measure the cylinder bore and subtract the piston size.

Mark	Size mm (in.)		
	B	2B	3B
1	95.00-95.01 (3.7402-3.7405)	98.00-98.01 (3.8583-3.8587)	102.00-102.01 (4.0157-4.0161)
2	95.01-95.02 (3.7405-3.7409)	98.01-98.02 (3.8587-3.8590)	102.01-102.02 (4.0161-4.0165)
3	95.02-95.03 (3.7409-3.7413)	98.02-98.03 (3.8590-3.8594)	102.02-102.03 (4.0165-4.0169)

Fig. 3-153

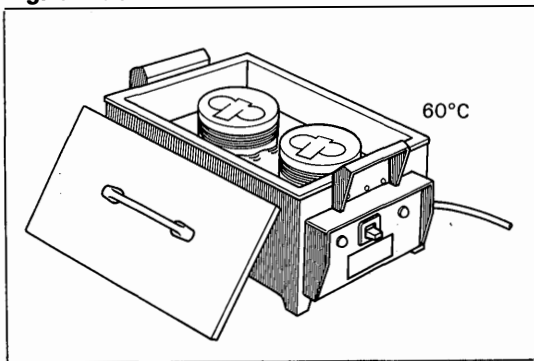

Piston oil clearance:

**0.09 – 0.11 mm
(0.0035 – 0.0043 in.)**

3. Assemble the piston and connecting rod as follows.

- (1) Heat the piston to about 60°C (140°F) before installing the piston pin.

Fig. 3-154

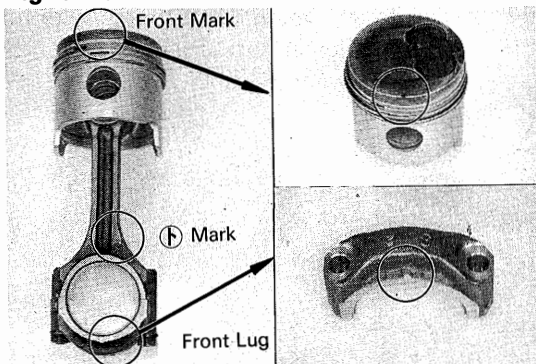

- (2) Align the front mark of the piston and the $\text{\textcircled{T}}$ mark of the connecting rod as shown in the figure.

Fig. 3-155

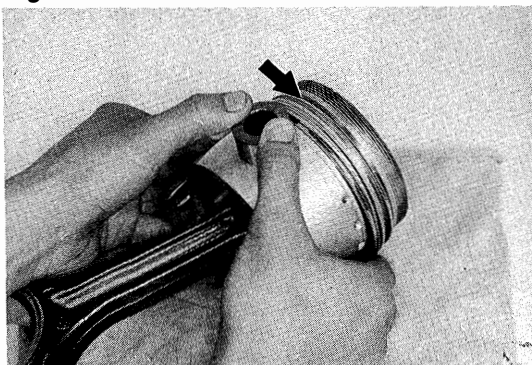

- (3) Normally the pin can be pushed in by hand, but if difficult, drive it in with a brass bar or such.

Fig. 3-156

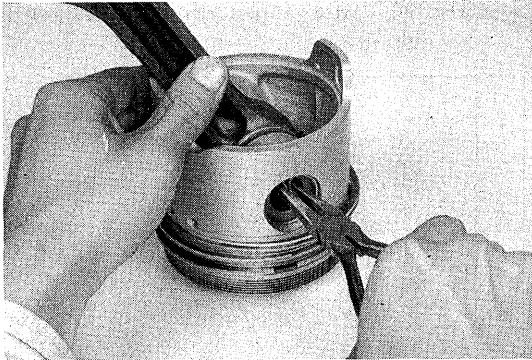

- (4) Install the snap rings on both sides.

—Note—

Make sure that the snap rings are installed correctly in the grooves.

Fig. 3-157

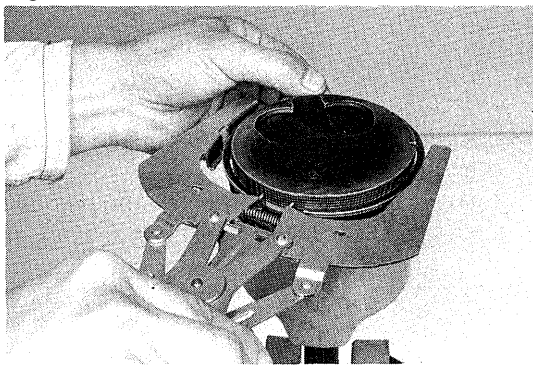

Piston Ring

1. Remove the piston ring with a piston ring expander.

Fig. 3-158

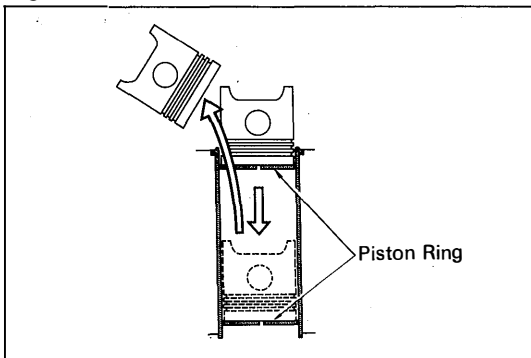

2. Measure the piston ring end gap with the ring at the lower part of the cylinder bore where the wear is least.

—Note—

Use the correct size rings to match the piston size.

Fig. 3-159

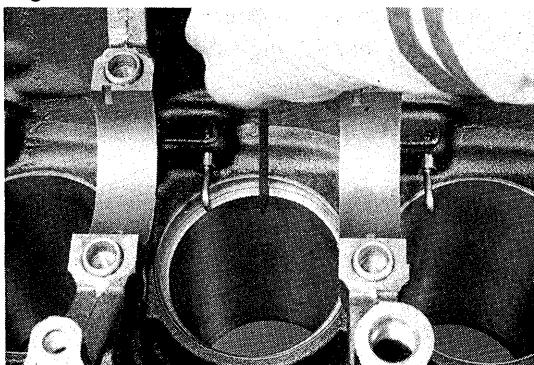

3. Measure the end gaps of No.1, No.2 and oil rings.

End gap:

B engine

0.35 – 0.55 mm
(0.0138 – 0.0217 in.)

2B & 3B engine

0.40 – 0.60 mm
(0.0157 – 0.0236 in.)

Fig. 3-160



4. Clean the ring grooves with a groove cleaning tool or broken ring.

Fig. 3-161

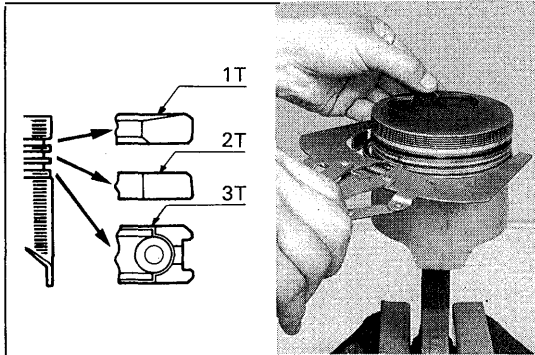

5. Install the piston ring with a piston ring expander.

—Note—

1. Always install the rings with the code marks facing up.

Fig. 3-162

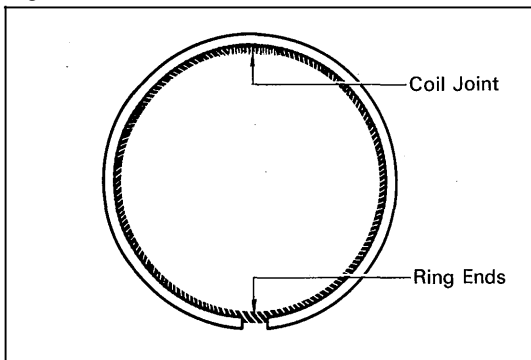

2. To assemble the oil ring and expander coil, make sure that the expander coil joint is at the opposite side of the ring ends.

Fig. 3-163

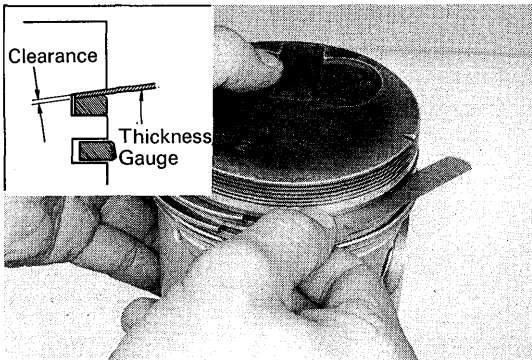

6. Measure the No.1 ring groove clearance with a thickness gauge when the ring is flush with the piston surface. If it exceeds specification, replace the ring and/or piston.

No.1 ring to groove clearance:

0.04 – 0.06 mm

(0.0016 – 0.0024 in.)

Fig. 3-164



7. Measure the No.2 and oil ring groove clearance.

If it exceeds specification, replace the ring and/or piston.

Ring to groove clearance:

No.2 0.04 – 0.06 mm
(0.0016 – 0.0024 in.)

Oil ring 0.03 – 0.07 mm
(0.0012 – 0.0028 in.)

Fig. 3-165

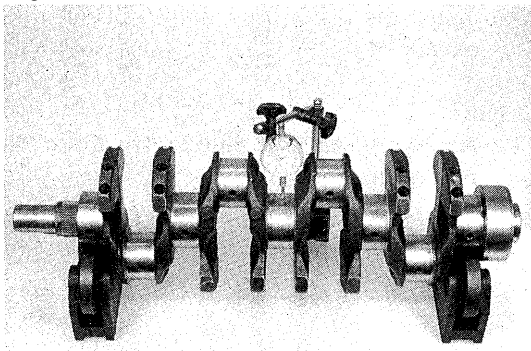

Crankshaft & Bearing

1. Check the crankshaft for runout and if it exceeds limit, replace.

Circle runout:

Limit 0.06 mm
(0.0024 in.)

Fig. 3-166

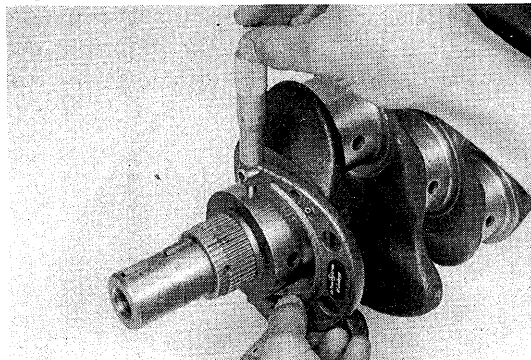

2. Measure the crankshaft main journal. If wear is excessive, the crankshaft must be reground or replaced.

Main journal diameter:

STD 69.98 – 70.00 mm
(2.7551 – 2.7559 in.)

Fig. 3-167

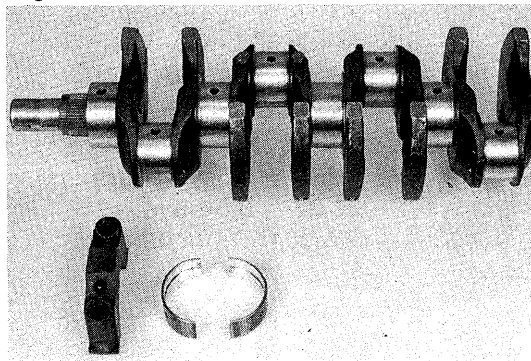

3. Measure the main journal oil clearance.
(1) Clean the journal, cap and bearing.

Fig. 3-168

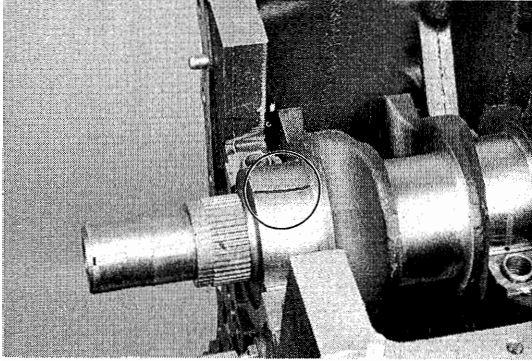

- (2) Lay a strip of plastigage across the journal.

Fig. 3-169

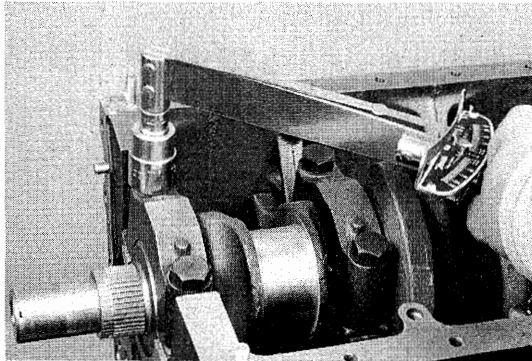

- (3) Tighten the cap bolts to specified torque.

Tightening torque:
12.8 – 14.2 kg-m
(93 – 102 ft-lb)

—Note—
Do not turn the crankshaft.

Fig. 3-170

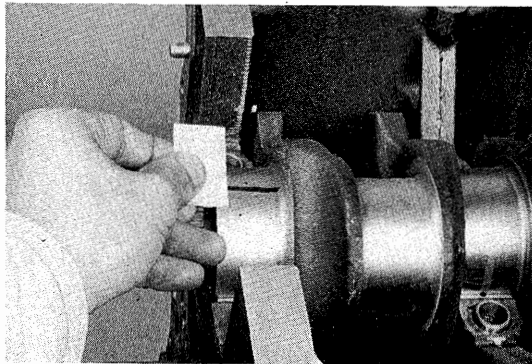

- (4) Measure the plastigage at its widest point. If clearance is not within specification, replace the bearings.

Oil clearance:
STD 0.03 – 0.07 mm
(0.0012 – 0.0028 in.)
Limit 0.1 mm
(0.004 in.)
U/S bearing type
0.25, 0.50, 1.00

Fig. 3-171

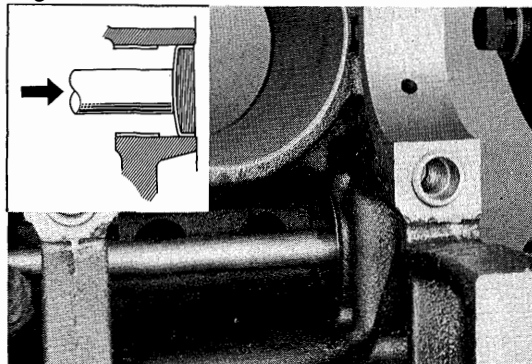

Camshaft Bearing

1. Remove the camshaft rear expansion plug.

Fig. 3-172

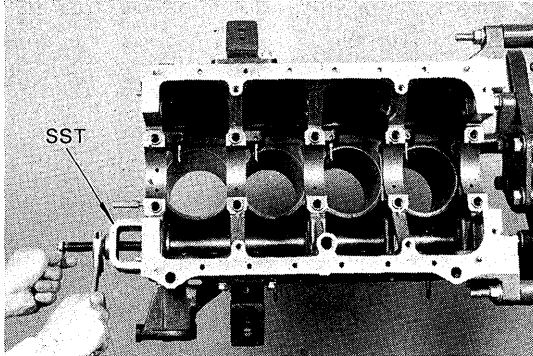

- Remove the camshaft bearings with SST. SST [09215-56010]

—Note—

Remove the bearings one at a time.

Fig. 3-173

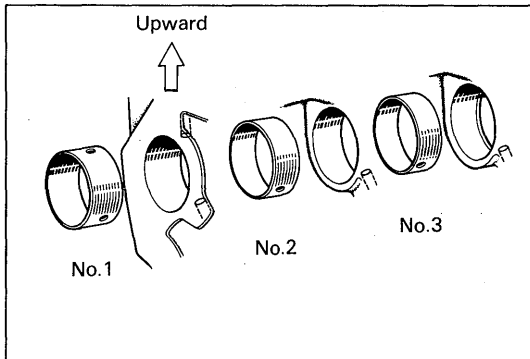

- Align the bearing oil holes.

Fig. 3-174

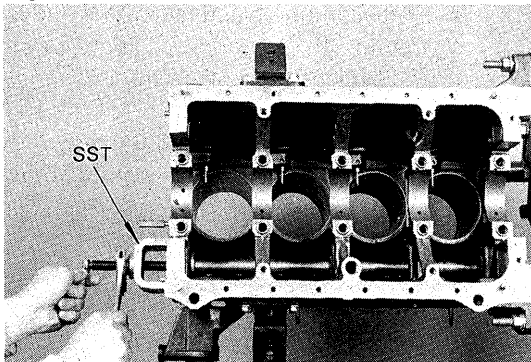

- Install new bearings with SST. SST [09215-56010]

—Note—

Install each bearing one at a time.

Fig. 3-175

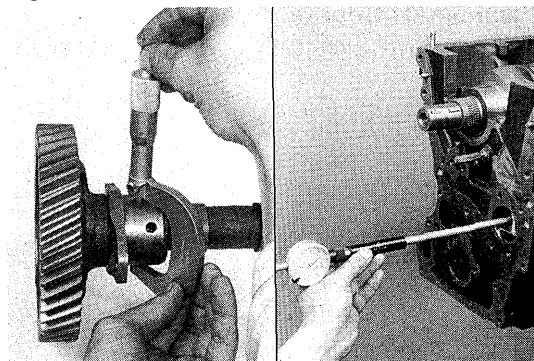

- Check the bearing oil clearance.

Oil clearance:

STD 0.03 – 0.07 mm
(0.0012 – 0.0028 in.)

Limit 0.1 mm
(0.004 in.)

Fig. 3-176

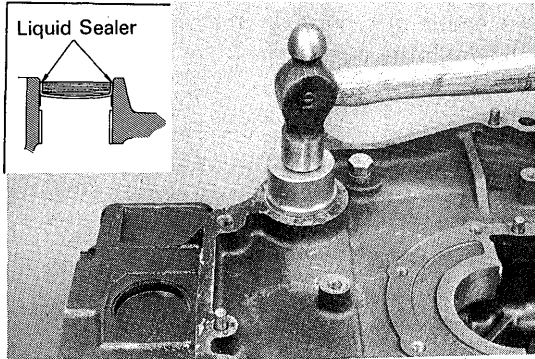

6. Install a new expansion plug with liquid sealer.

Fig. 3-177

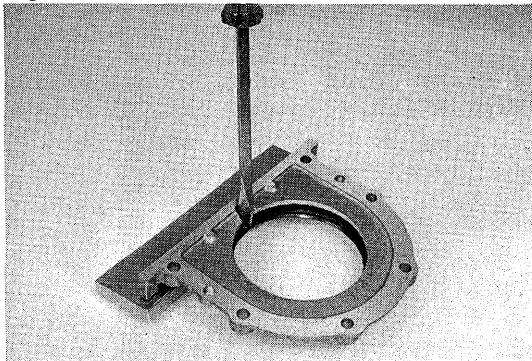
**Crankshaft Rear Oil Seal**

1. Remove the oil seal with a screwdriver.

Fig. 3-178

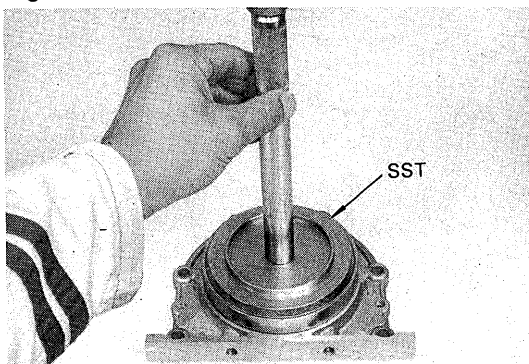

2. Install a new oil seal with SST.
SST [09550-55010]

ASSEMBLY

Assemble the parts in the numerical order shown in the figure.

Fig. 3-179

-Note-

1. Thoroughly clean all parts to be assembled.
2. Apply clean engine oil to all sliding and rotating surfaces of the parts before assembly.

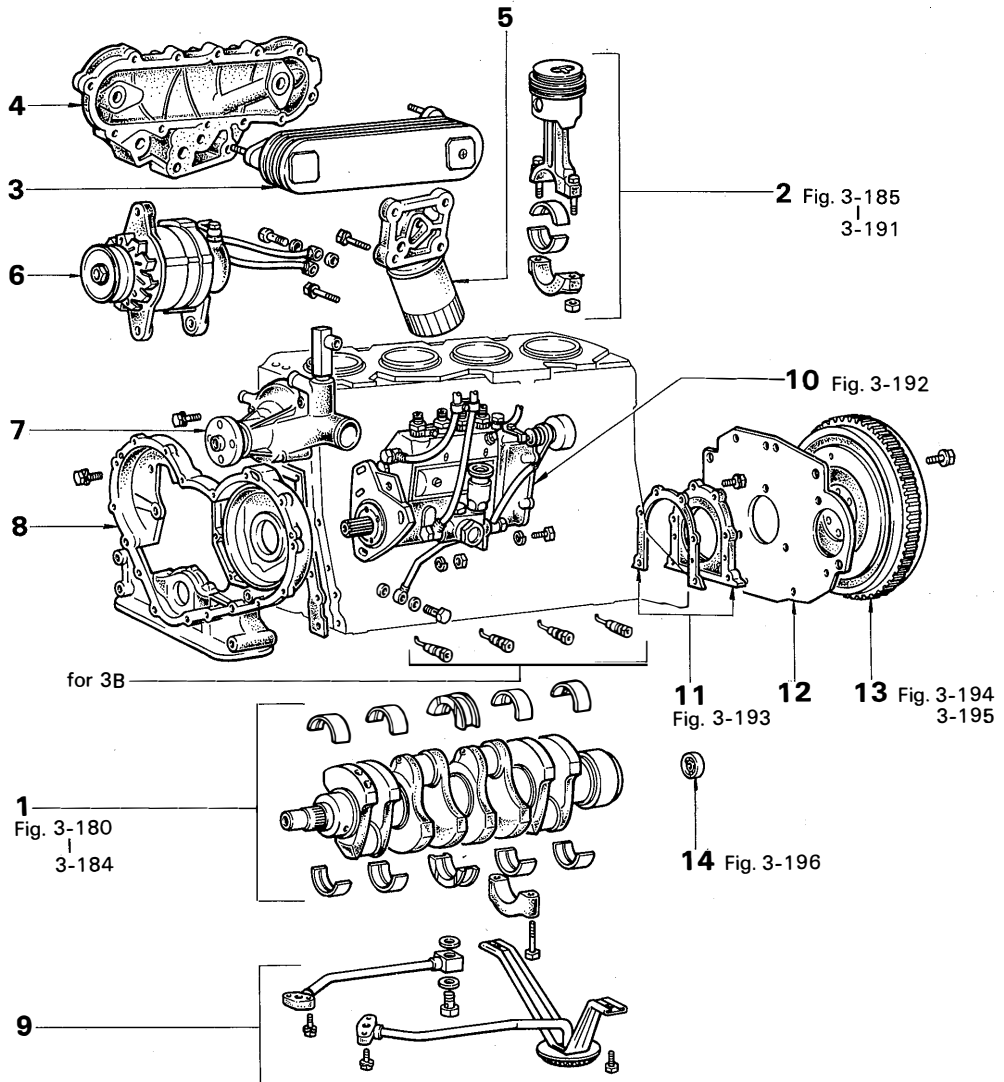

- | | |
|--|---|
| <ol style="list-style-type: none"> 1. Crankshaft 2. Piston & Connecting Rod 3. Oil Cooler 4. Oil Cooler Cover 5. Oil Filter 6. Alternator 7. Water Pump | <ol style="list-style-type: none"> 8. Timing Gear Case 9. Oil Strainer & Connecting Rod 10. Injection Pump 11. Rear Oil Seal 12. Rear End Plate 13. Flywheel 14. Input Shaft Bearing |
|--|---|

Fig. 3-180

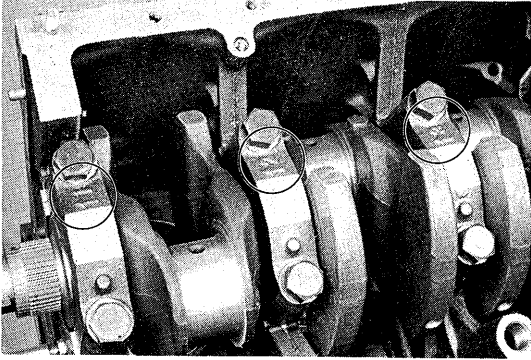

Face the arrow marks toward the front.

Fig. 3-181

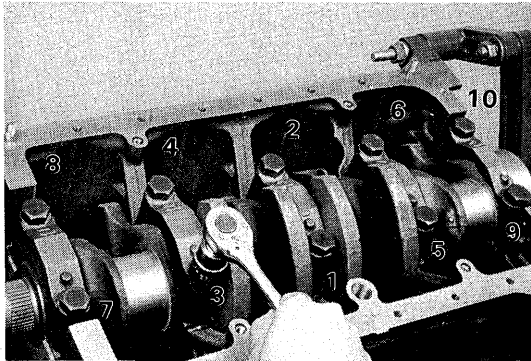

Tighten each bearing cap bolt a little at a time in the sequence shown in the figure.

Fig. 3-182

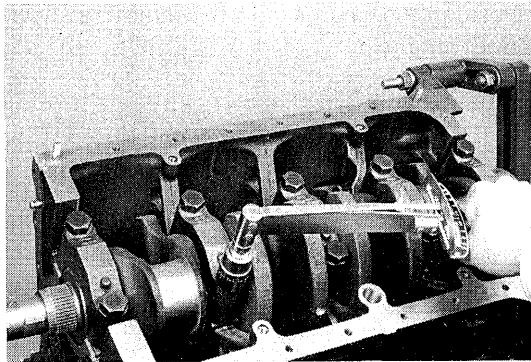

Tighten the bearing caps to specified torque.

Tightening torque:

12.8 – 14.2 kg-m

(93 – 102 ft-lb)

Fig. 3-183

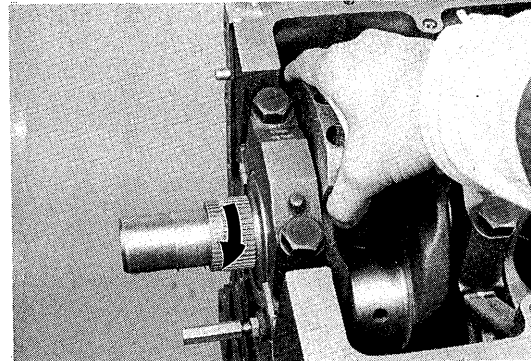

—Note—

Check for tightness of crankshaft rotation after tightening each bearing.

Fig. 3-184

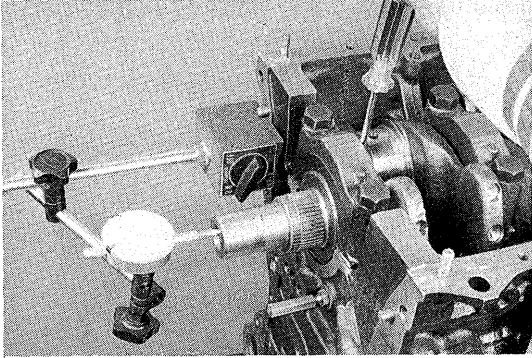

Measure the crankshaft thrust clearance.

Thrust clearance:

STD 0.07 – 0.18 mm
(0.0028 – 0.0071 in.)

Limit 0.3 mm
(0.012 in.)

Fig. 3-185

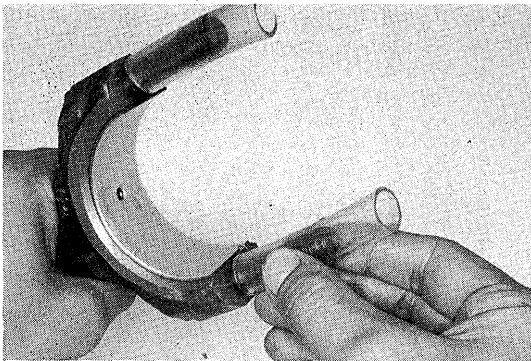

Cover the rod bolts with short hoses to protect crankpins from damage.

Fig. 3-186

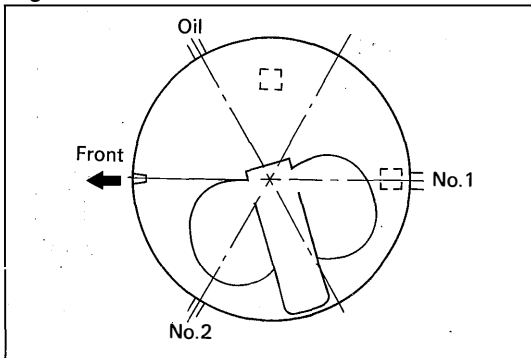

Position the ring gaps in the direction shown in the figure.

Fig. 3-187

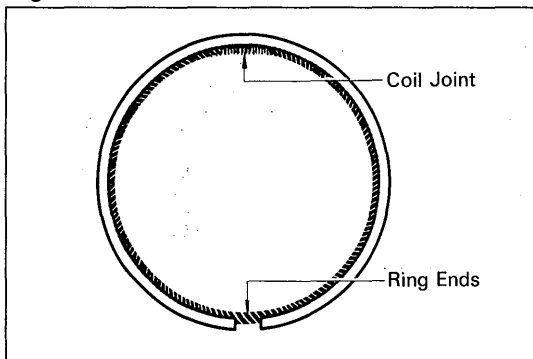

The oil ring ends should be at the opposite side of the expander coil joint.

Fig. 3-188

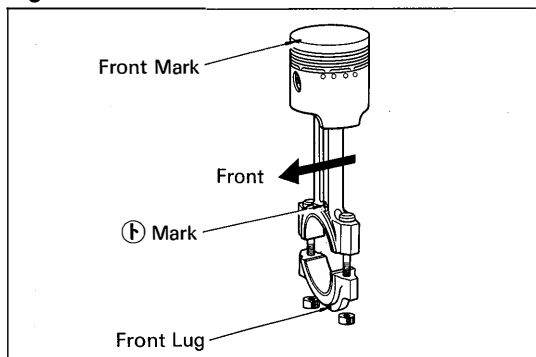

Assemble matching numbered piston/rod assemblies with the notch on the piston and the  mark on the connecting rod facing the front.

Fig. 3-189



Insert the piston into the cylinder while compressing the rings with a piston ring compressor.

—Note—

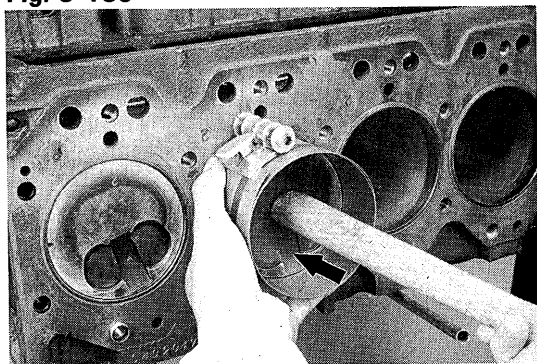
Use care not to break the piston ring. And, as for 3B engine, be careful not to damage the oil nozzle point.

Fig. 3-190

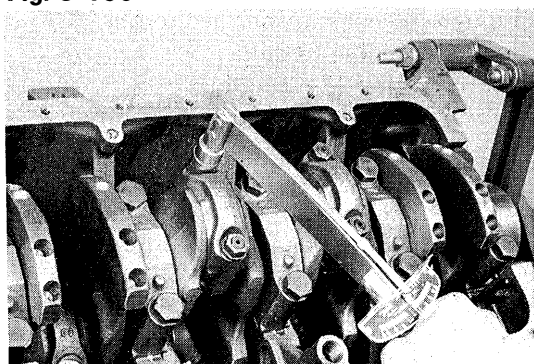

Tighten the connecting rod caps to specified torque.

Tightening torque:

B, 2B	6.5 – 7.5 kg-m (48 – 54 ft-lb)
3B	8.5 – 9.5 kg-m (62 – 68 ft-lb)

—Note—

Check for tightness of crankshaft rotation after tightening each bearing.

Fig. 3-191

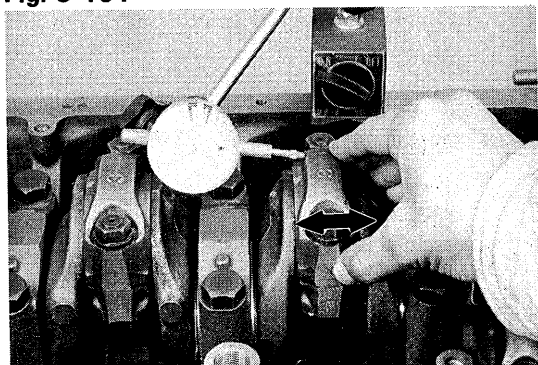

Check the connecting rod thrust clearance.

Thrust clearance:

STD	0.08 – 0.20 mm (0.0031 – 0.0079 in.)
Limit	0.3 mm (0.012 in.)

Fig. 3-192

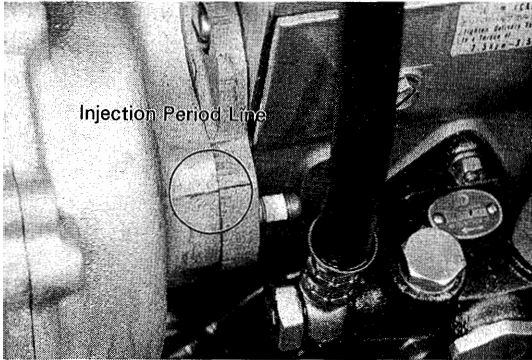

Set the injection period line back to the former position.

Fig. 3-193

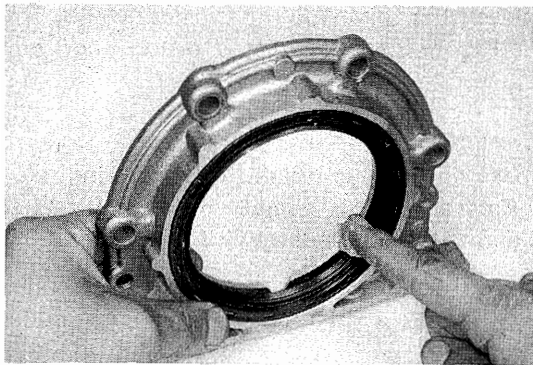

Apply MP grease on the oil seal lip before assembling.

Fig. 3-194

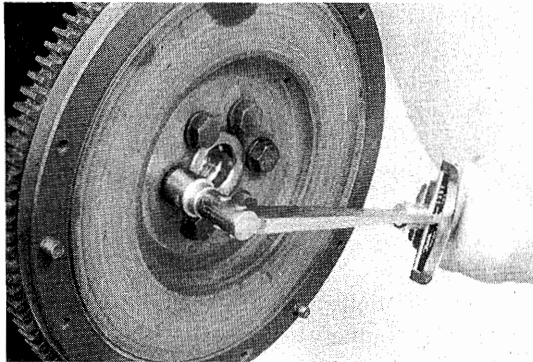

Tighten the bolts to specified torque.

Tightening torque:
12.8 – 14.2 kg-m
(93 – 102 ft-lb)

—Note—

Apply a light coat of engine oil on the bolt threads and under the bolt head before installing.

Fig. 3-195

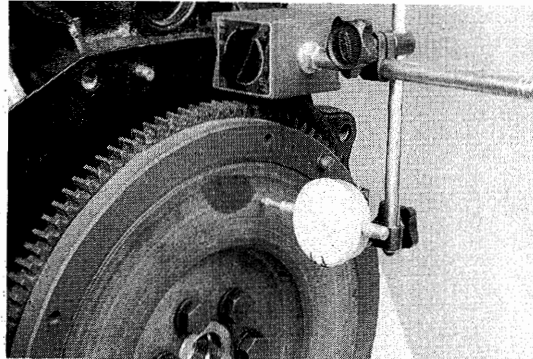

Check the flywheel for runout.

Runout:
Limit 0.2 mm
(0.008 in.)

Fig. 3-196

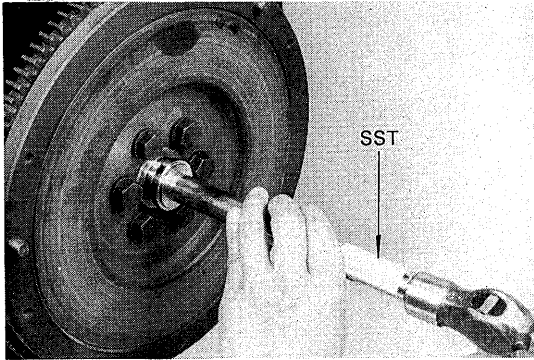

Drive in the input shaft bearing with SST.
SST [09608-20011]

LUBRICATION SYSTEM

	Page
LUBRICATION SYSTEM CIRCUIT	4-2
OIL FILTER	4-3
OIL PUMP	4-7

LUBRICATION SYSTEM CIRCUIT

Fig. 4-1

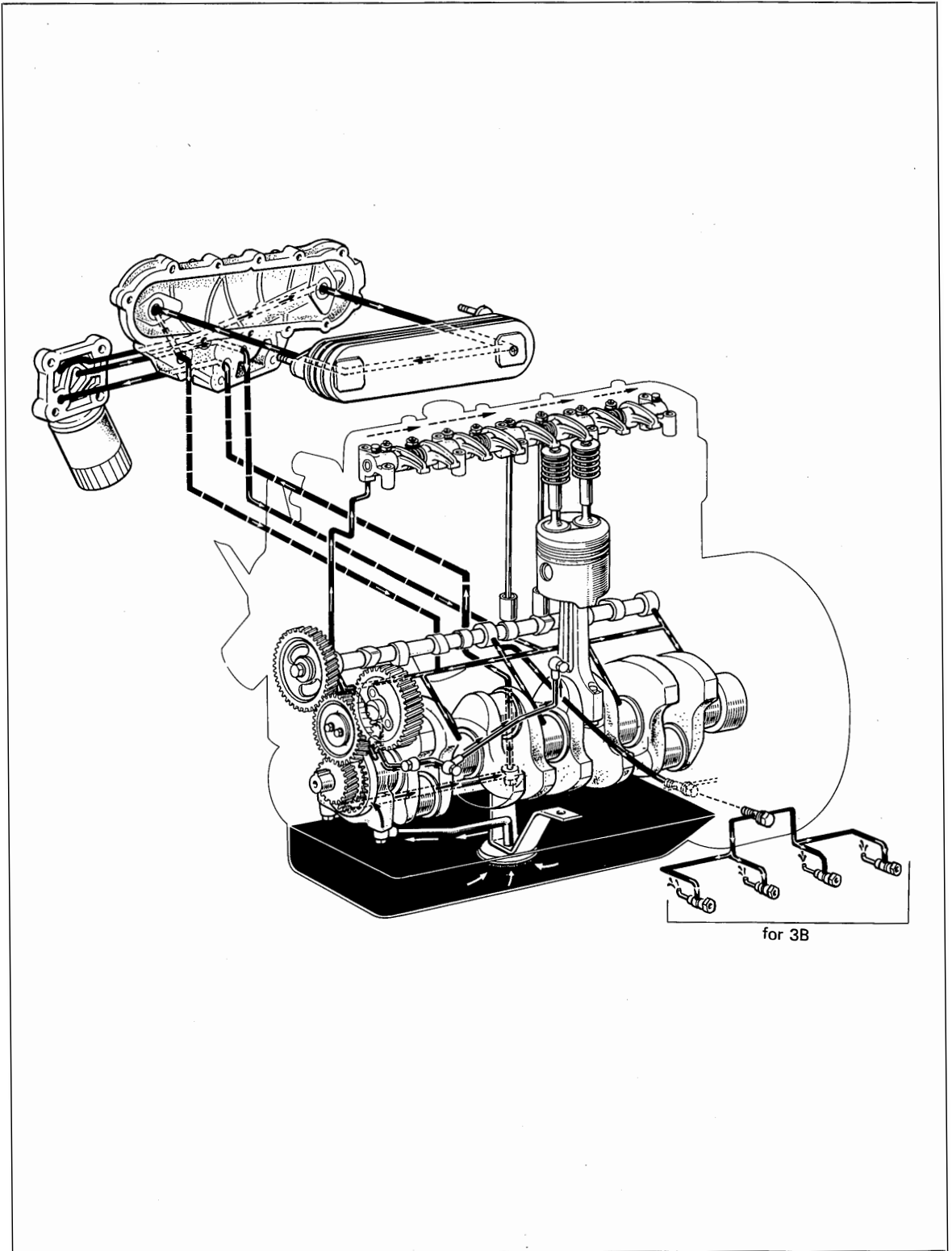

for 3B

OIL FILTER

DISASSEMBLY

Disassemble the parts in the numerical order shown in the figure.

Fig. 4-2

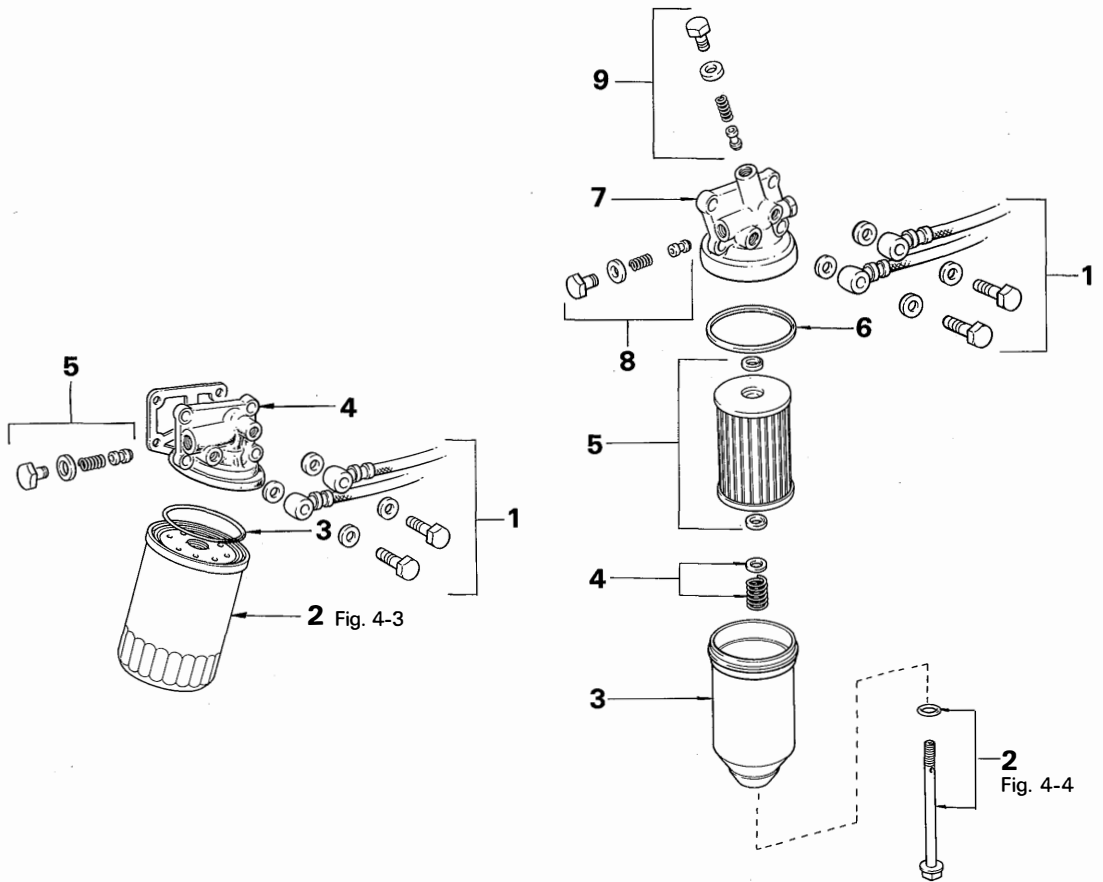

[Cartridge Type]

1. Oil Hose
2. Oil Filter Element
3. Oil Filter Body Gasket
4. Oil Filter Cap
5. Oil Cooler By-pass Valve

[Paper Element Type]

1. Oil Hose
2. Oil Filter Cartridge Guide & Gasket
3. Oil Filter Case
4. Oil Filter Element Support Spring & Washer
5. Oil Filter Element & Gasket
6. Oil Filter Body Gasket
7. Oil Filter Cap
8. Oil Cooler Bypass Valve
9. Oil Filter Bypass Valve

Fig. 4-3

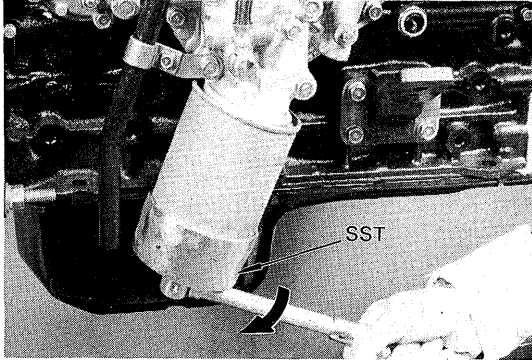

[Cartridge Type]

Remove the oil filter with SST.
SST [09228-44010]

Fig. 4-4

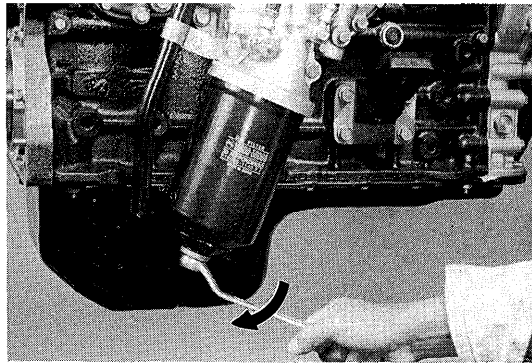

[Paper Element Type]

Remove the oil filter cartridge guide.

Fig. 4-5

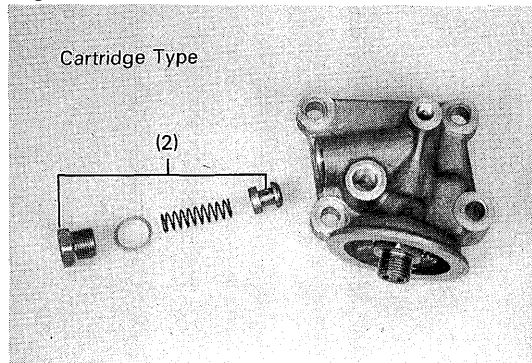

INSPECTION

1. Check the contacting surface of the oil filter cap for scoring and cracks.
2. Check the sliding condition of the following valves.
 - (1) Oil filter bypass valve (for Paper Element Type)
 - (2) Oil cooler bypass valve (for both types)

Fig. 4-6

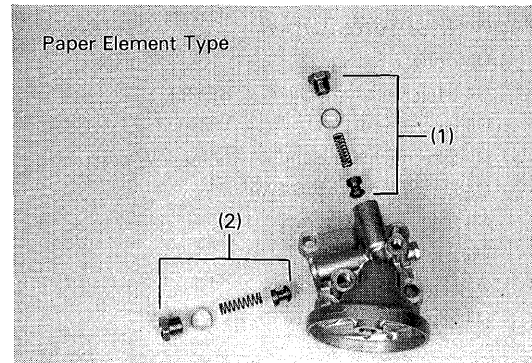

ASSEMBLY

Assemble the parts in the numerical order shown in the figure.

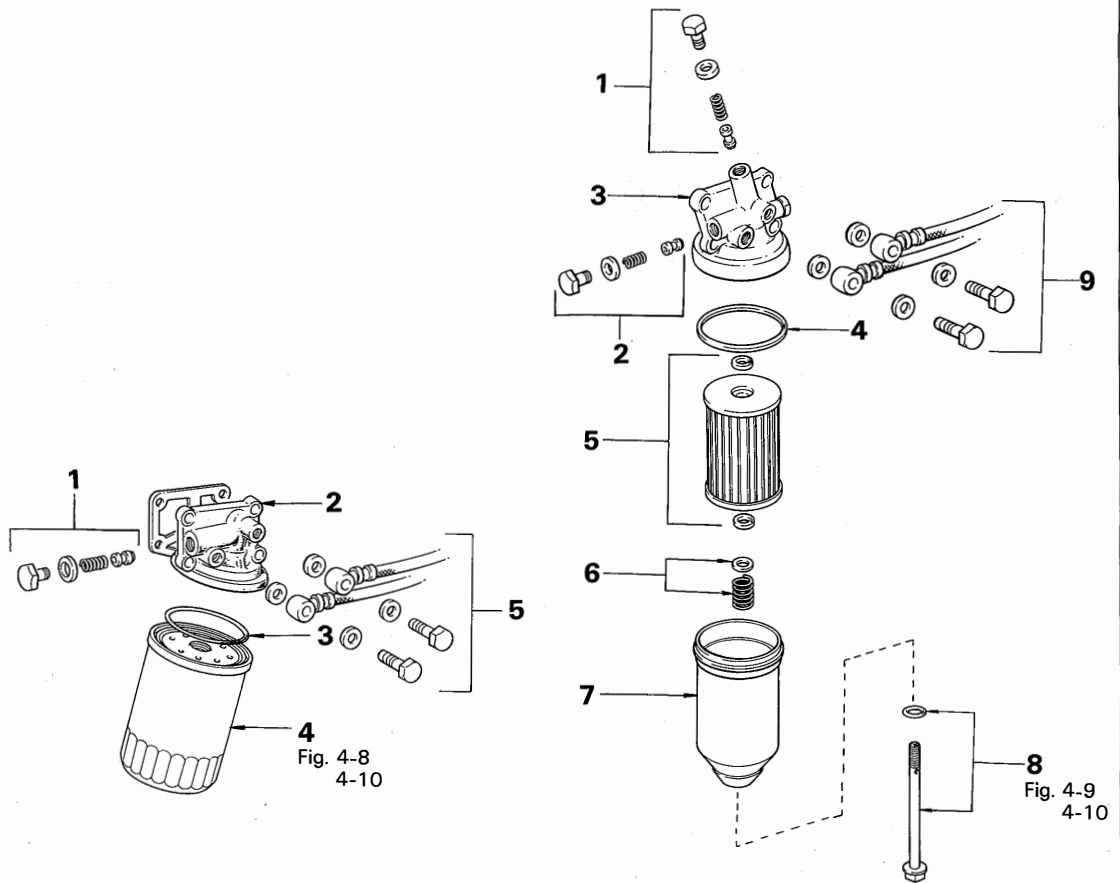
Fig. 4-7**[Cartridge Type]**

1. Oil Cooler By-pass Valve
2. Oil Filter Cap
3. Oil Filter Body Gasket
4. Oil Filter Element
5. Oil Hose

[Paper Element Type]

1. Oil Filter Bypass Valve
2. Oil Cooler Bypass Valve
3. Oil Filter Cap
4. Oil Filter Body Gasket
5. Oil Filter Element & Gasket
6. Oil Filter Element Support Spring & Washer
7. Oil Filter Case
8. Oil Filter Cartridge Guide & Gasket
9. Oil Hose

Fig. 4-8

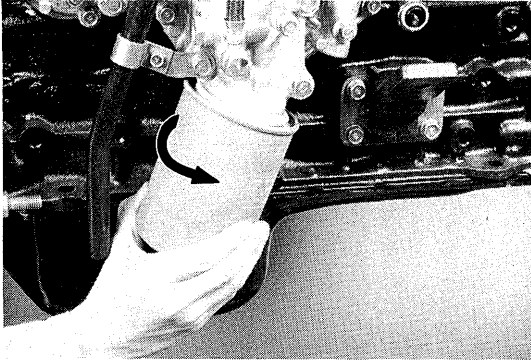
**[Cartridge Type]**

Install the oil filter and tighten it firmly by hand.

–Note–

Do not tighten the filter with SST or a wrench.

Fig. 4-9

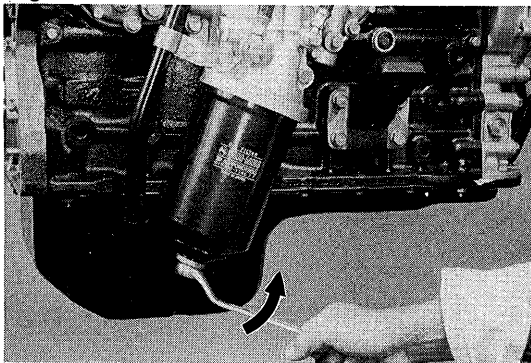
**[Paper Element Type]**

Tighten the oil filter cartridge guide.

–Note–

1. Make sure that the gasket is installed correctly in the groove of the filter cap.
2. Do not damage the element by over-tightening the oil filter cartridge guide.

Fig. 4-10

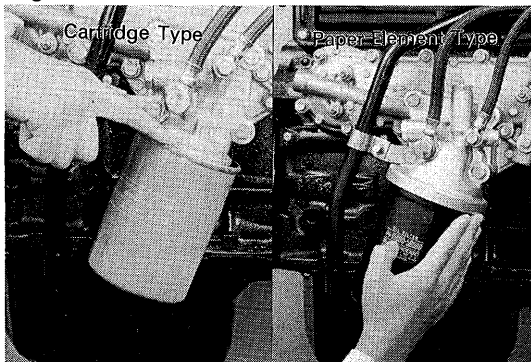
**–Note–**

After installing, start the engine and check for oil leakage.

Then, stop the engine and recheck the oil level.

OIL PUMP**REMOVAL**

Remove the parts in the numerical order shown in the figure.

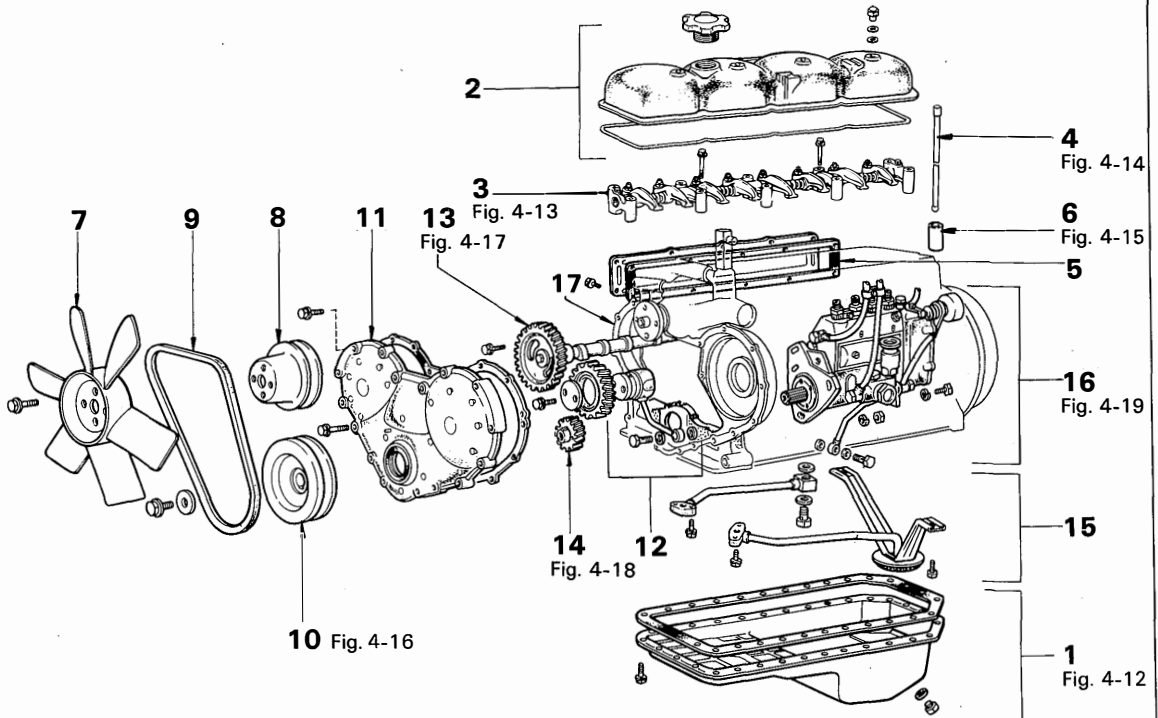
Fig. 4-11

- | | |
|--------------------------------|---|
| 1. Oil Pan | 10. Crankshaft Pulley |
| 2. Cylinder Head Cover | 11. Timing Gear Cover & Automatic Timer |
| 3. Valve Rocker Shaft Assembly | 12. Idle Gear & Shaft |
| 4. Valve Push Rod | 13. Camshaft & Timing Gear |
| 5. Valve Push Rod Cover | 14. Crankshaft Timing Gear |
| 6. Valve Lifter | 15. Oil Strainer & Pipe |
| 7. Cooling Fan | 16. Injection Pump & Oil Pipe |
| 8. Fan Pulley | 17. Timing Gear Case & Oil Pump |
| 9. V Belt | |

Fig. 4-12

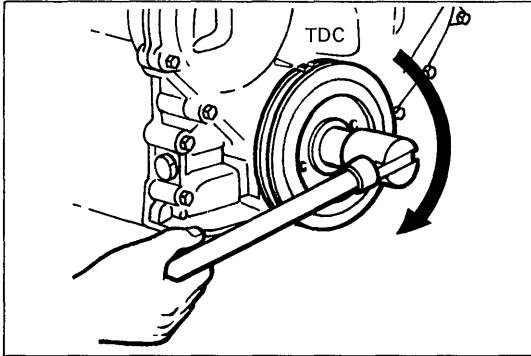

Before starting work, set No.1 cylinder piston to TDC/compression.

Fig. 4-13

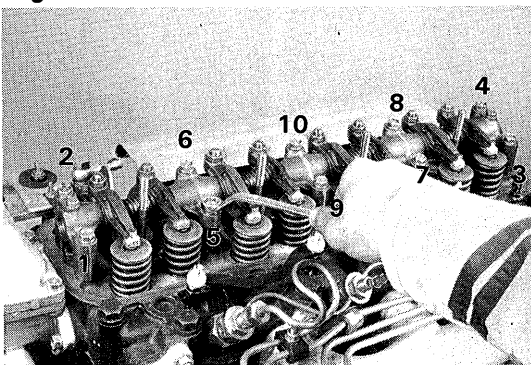

Loosen each rocker support bolt a little at a time in the sequence shown in the figure.

Fig. 4-14

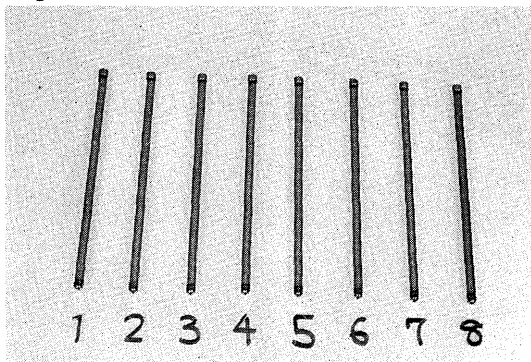

Keep the push rods in correct order.

Fig. 4-15

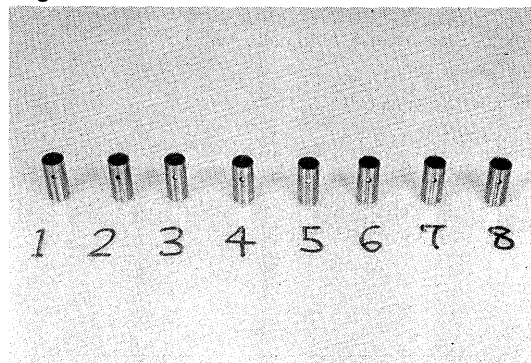

Keep the valve lifters in correct order.

Fig. 4-16

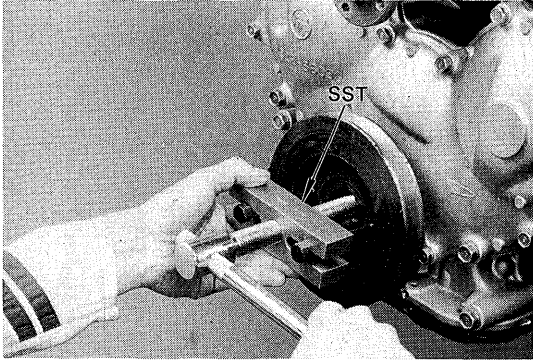

Pull out the crankshaft pulley with SST.
SST [09213-60016]

Fig. 4-17

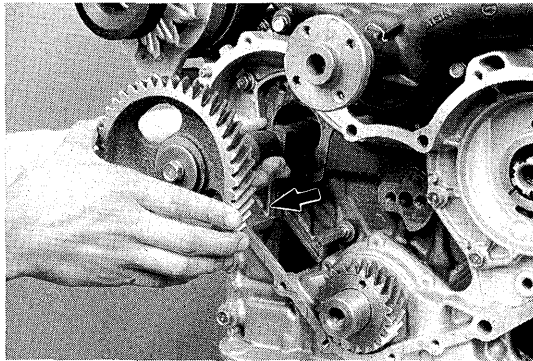

Pull out the camshaft, using care not to
damage the camshaft bearings.

Fig. 4-18

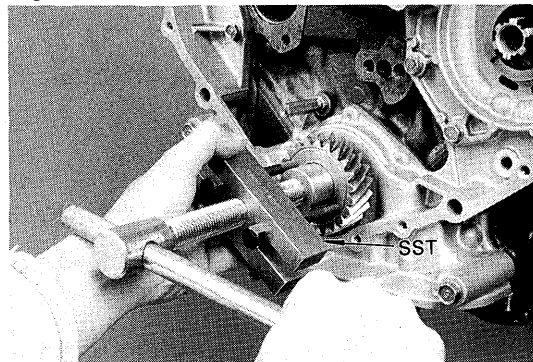

Pull out the crankshaft timing gear with SST.
SST [09213-60016]

Fig. 4-19

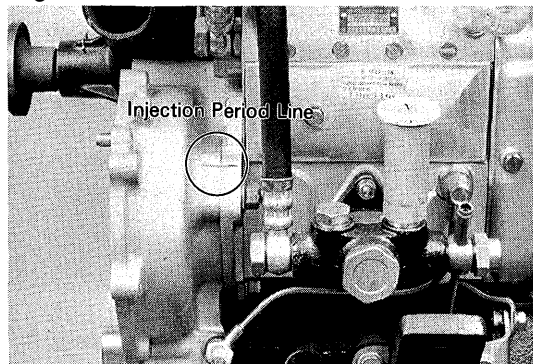

Check the position of the injection period line,
and remove the three injection pump mounting
nuts and oil pipe union bolt.

DISASSEMBLY

Disassemble the parts in the numerical order shown in the figure.

Fig. 4-20

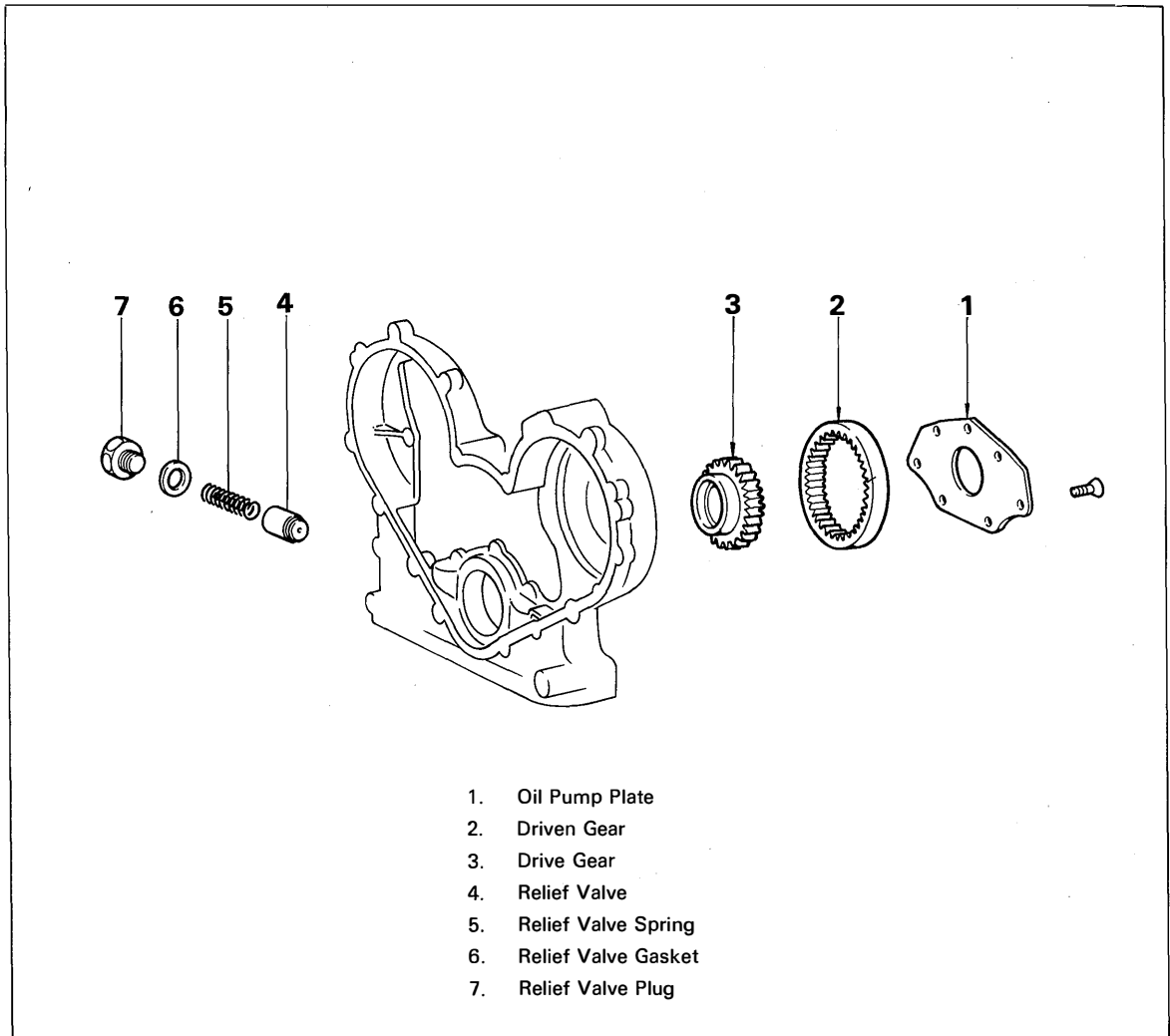
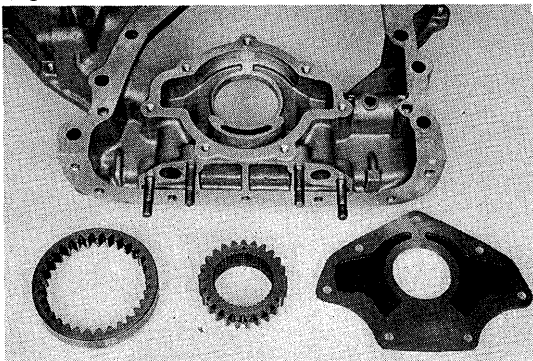
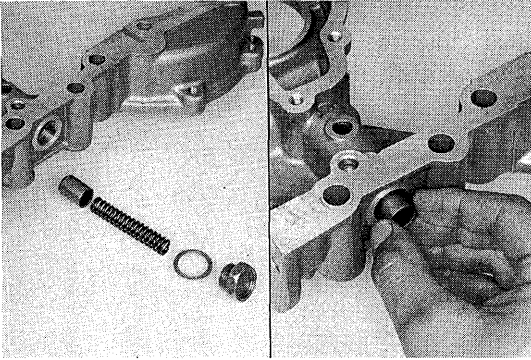

Fig. 4-21

**INSPECTION**

1. Check disassembled parts for wear or damage.

Fig. 4-22



2. Check the relief valve for wear or scoring, and see if it slides smoothly.

Fig. 4-23

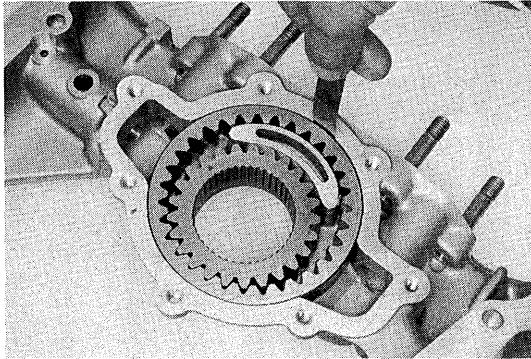

3. Measure the body clearance.

Body clearance:

STD 0.06 – 0.15 mm
(0.0024 – 0.0059 in.)

Limit 0.3 mm
(0.012 in.)

Fig. 4-24

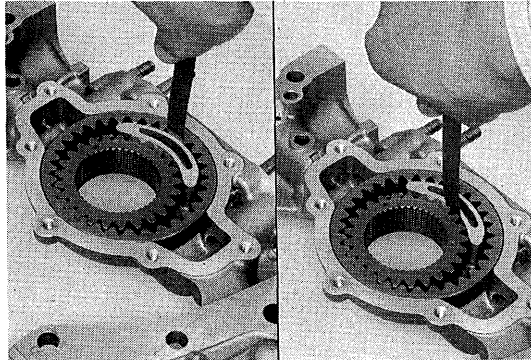

4. Measure the tip clearances.

Tip clearance:**STD**

Driven gear-crescent
0.15 – 0.21 mm
(0.0059 – 0.0083 in.)

Drive gear-crescent
0.22 – 0.25 mm
(0.0087 – 0.0098 in.)

Limit 0.3 mm
(0.012 in.)

Fig. 4-25

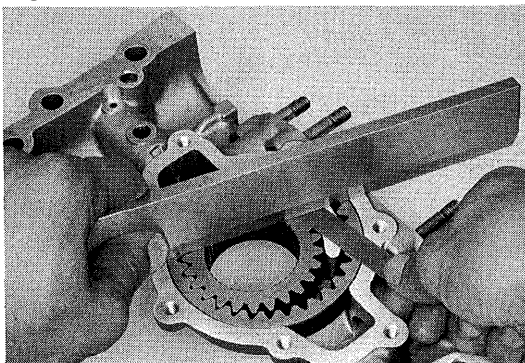

5. Measure the side clearance.

Side clearance:

STD 0.03 – 0.09 mm
(0.0012 – 0.0035 in.)

Limit 0.15 mm
(0.0059 in.)

ASSEMBLY

Assemble the parts in the numerical order shown in the figure.

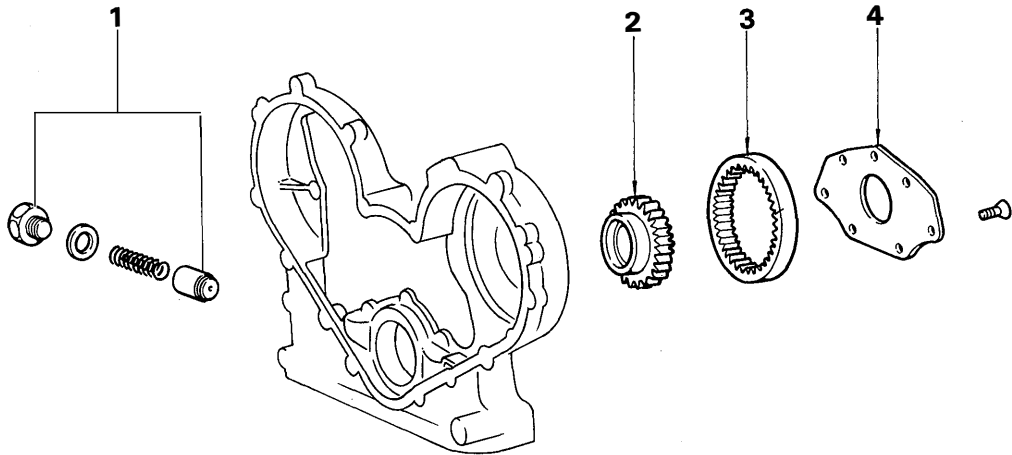
Fig. 4-26

1. Relief Valve
2. Drive Gear
3. Driven Gear
4. Oil Pump Plate

INSTALLATION

Install the parts in the numerical order shown in the figure.

Fig. 4-27

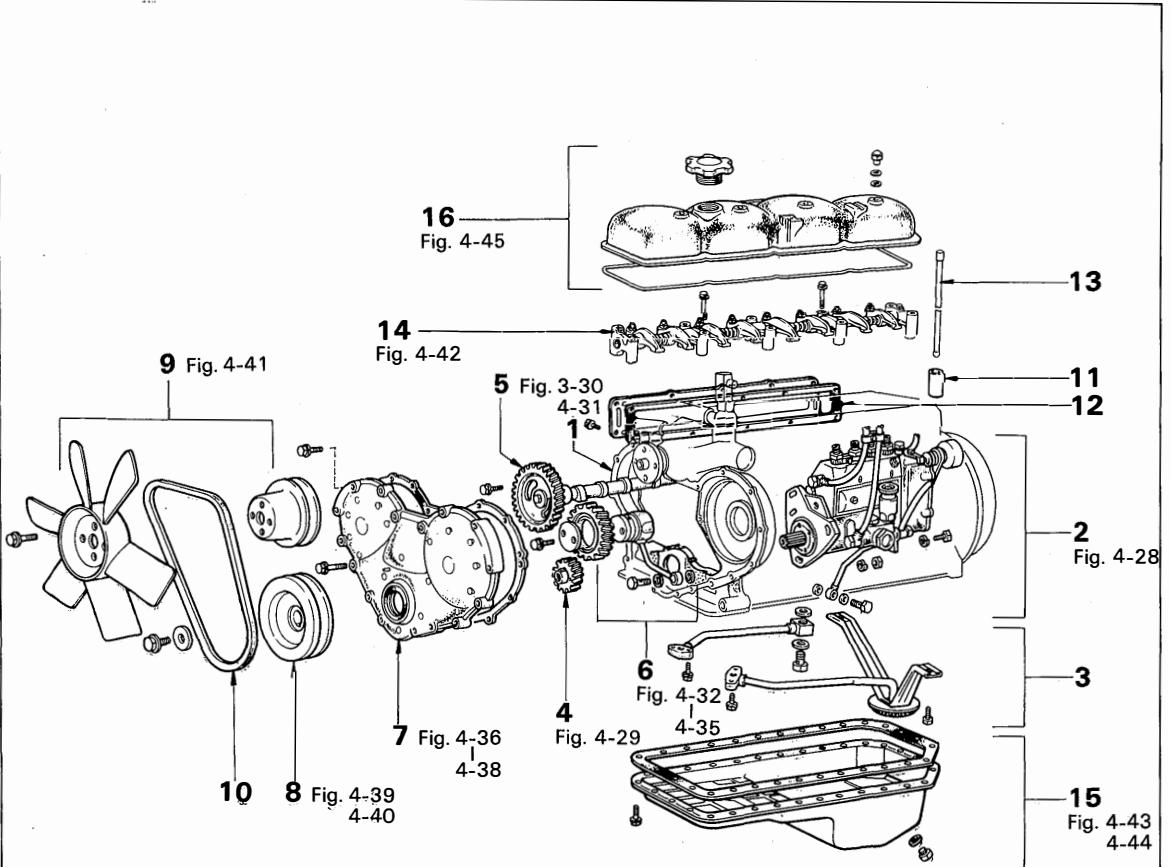

- | | |
|--|---------------------------------|
| 1. Timing Gear Case & Oil Pump | 9. Cooling Fan & Fan Pulley |
| 2. Injection Pump & Oil Pipe | 10. V Belt |
| 3. Oil Strainer & Pipe | 11. Valve Lifter |
| 4. Crankshaft Timing Gear | 12. Valve Push Rod Cover |
| 5. Camshaft & Timing Gear | 13. Valve Push Rod |
| 6. Idle Gear & Shaft | 14. Valve Rocker Shaft Assembly |
| 7. Timing Gear Cover & Automatic Timer | 15. Oil Pan |
| 8. Crankshaft Pulley | 16. Cylinder Head Cover |

Fig. 4-28

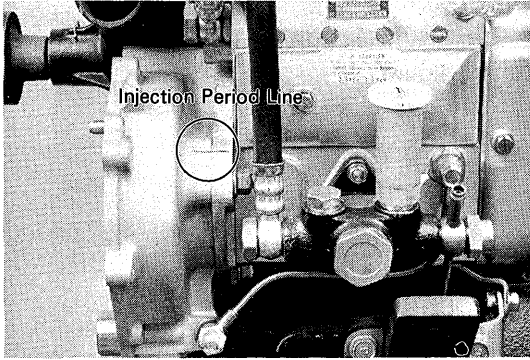

Set the injection period line back to the former position.

Fig. 4-29

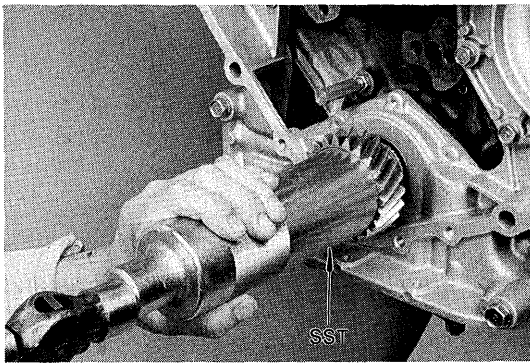

Drive in the crankshaft timing gear with SST.
SST [09316-60010]

Fig. 4-30

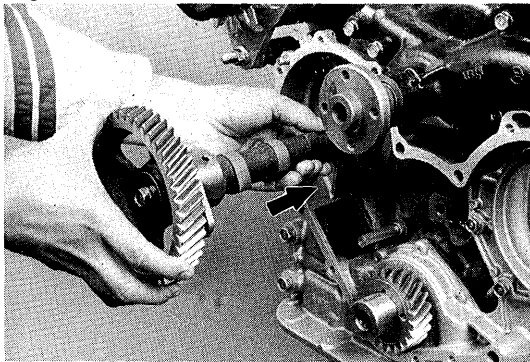

Insert the camshaft, using care not to damage the camshaft bearings.

Fig. 4-31

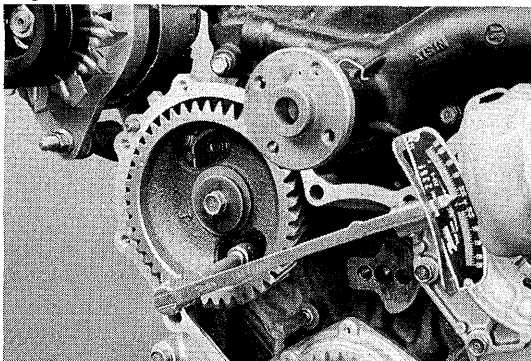

Tighten the camshaft thrust plate.

**Tightening torque: 1.5 – 2.2 kg-m
(11 – 15 ft-lb)**

Fig. 4-32

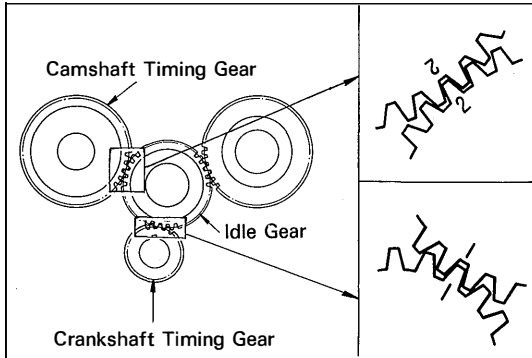

Set the idle gear aligning marks 1 and 2 respectively against crankshaft gear mark 1 and camshaft gear mark 2.

Fig. 4-33

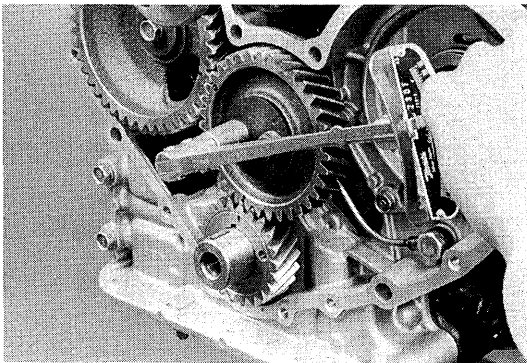

Tighten the idle gear and shaft.

**Tightening torque: 4.0 – 5.5 kg-m
(29 – 39 ft-lb)**

—Note—

Apply a light coat of engine oil on the bolt threads and under the bolt head before installing.

Fig. 4-34

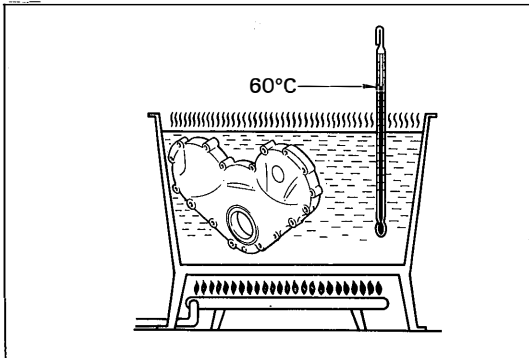

Remove the automatic timer from the timing gear cover after heating the cover to about 60°C (140°F).

Fig. 4-35

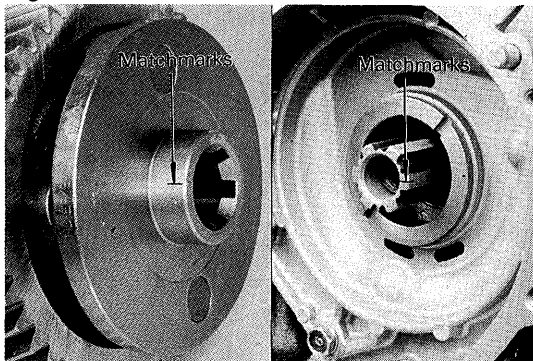

Align the matchmarks on the injection pump spline shaft and timer drive shaft when installing the automatic timer.

—Note—

Coat the splines and bearing with MP grease.

Fig. 4-36

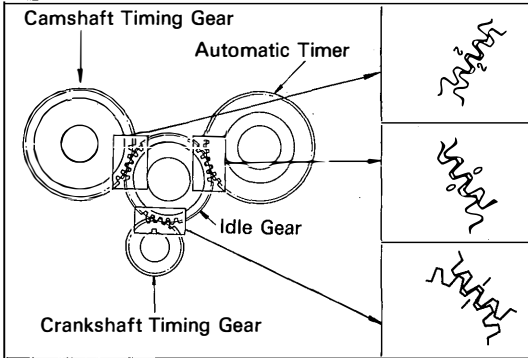

Align the idle gear 0 mark against the timer drive gear 0 mark.

Fig. 4-37

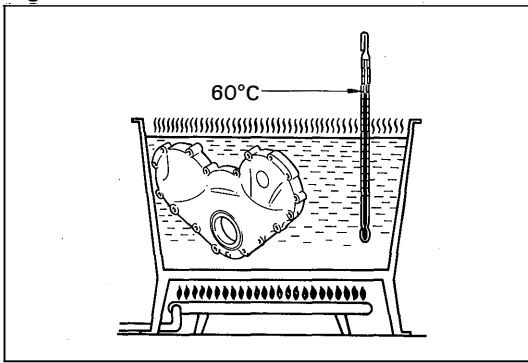

Heat the timing gear cover to about 60°C (140°F) before installing.

Fig. 4-38

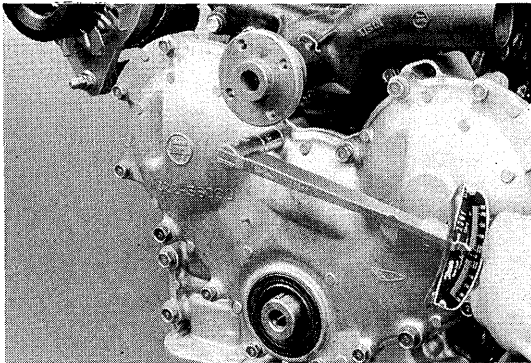

Tighten the timing gear cover.

Tightening torque:

8 mm bolt	1.5 – 2.2 kg-m (11 – 15 ft-lb)
10 mm bolt	3.0 – 4.5 kg-m (22 – 32 ft-lb)

Fig. 4-39

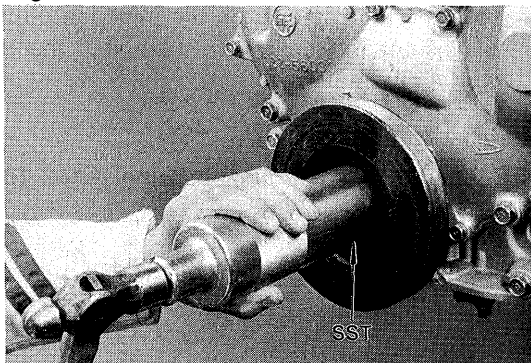

Drive in the crankshaft pulley with SST.
SST [09316-60010]

Fig. 4-40

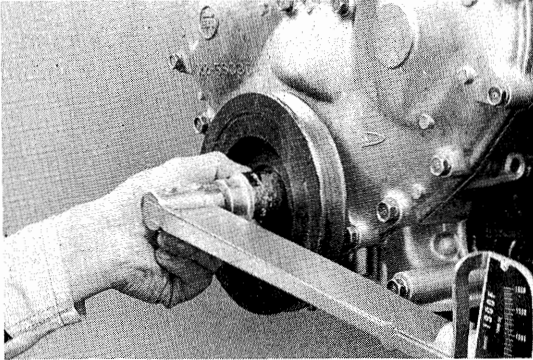

Tighten the retaining bolt.

**Tightening torque: 20.0 – 24.0 kg-m
(145 – 173 ft-lb)**

—Note—

Apply a light coat of engine oil on the bolt threads and under the bolt head before installing.

Fig. 4-41

**SEE
ENGINE TUNE-UP
SECTION
Fig. 2-7 & 2-8**

Adjust drive belt tension.

Fig. 4-42

**SEE
ENGINE SERVICE
SECTION
Fig. 3-56 to 3-61**

Adjust the valve clearance.

Fig. 4-43

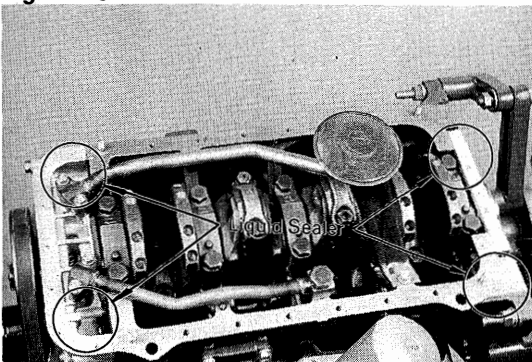

Apply liquid sealer to the cylinder block and gear cover at the areas shown in the figure.

Fig. 4-44

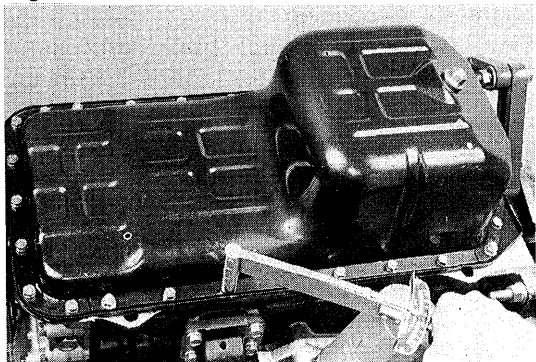

Install the oil pan.

Tightening torque: 0.7 – 1.3 kg-m
(61 – 112 in.-lb)

Fig. 4-45

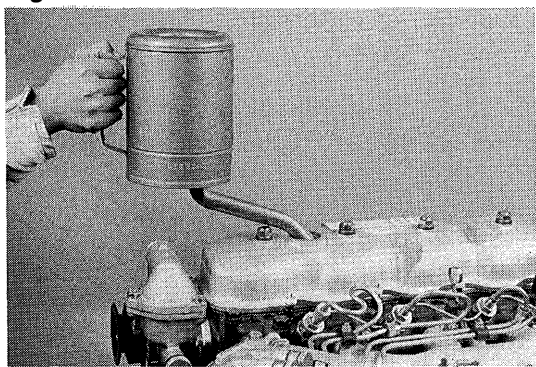

Fill the engine with engine oil.

Oil grade: API service CC-CD

Oil capacity:
(Dry refill, w/ Oil filter)

7.3 liters

(7.7 US qt, 6.4 Imp.qt)

COOLING SYSTEM

	Page
COOLING SYSTEM CIRCUIT	5-2
WATER PUMP CUTAWAY VIEW	5-2
WATER PUMP	5-3
RADIATOR	5-8
THERMOSTAT	5-8

COOLING SYSTEM CIRCUIT

Fig. 5-1

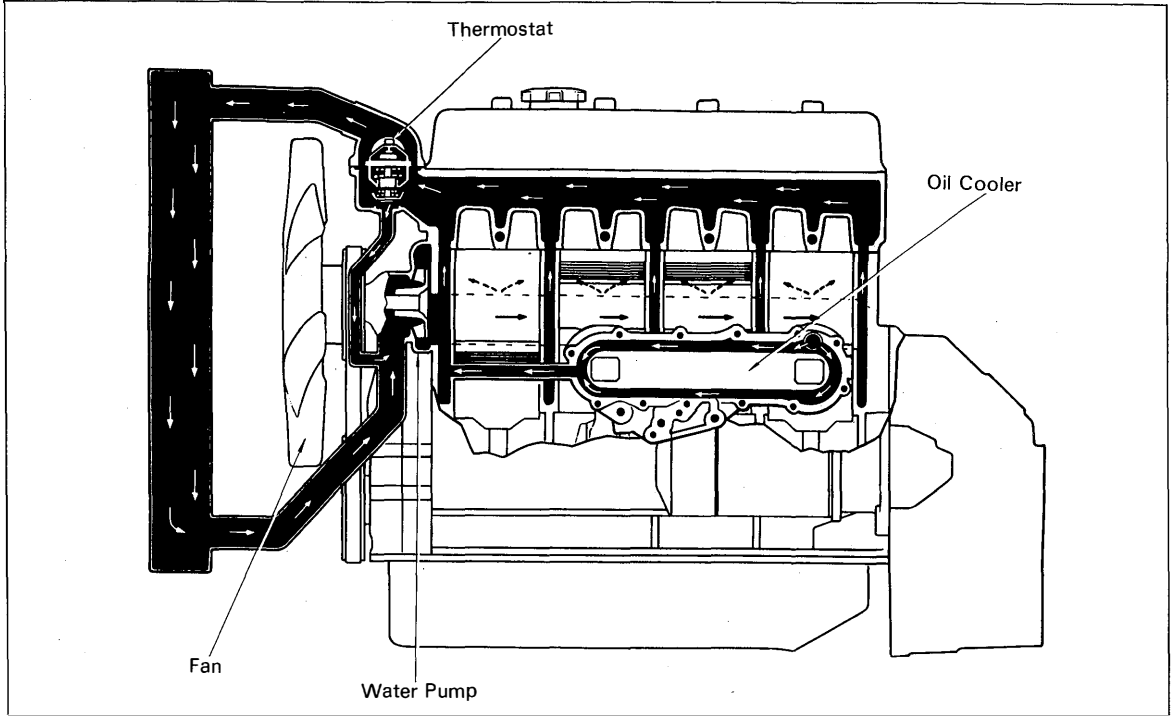

WATER PUMP CUTAWAY VIEW

Fig. 5-2

w/ Fluid Coupling

w/o Fluid Coupling

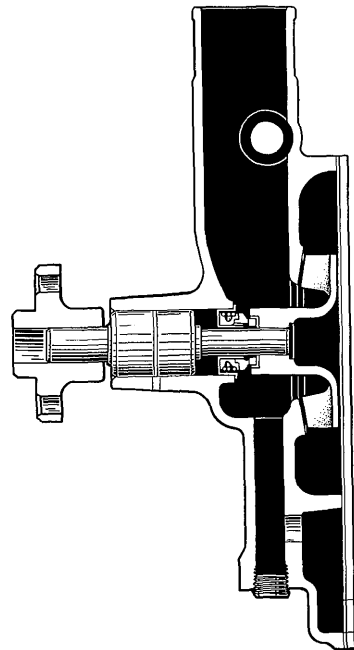
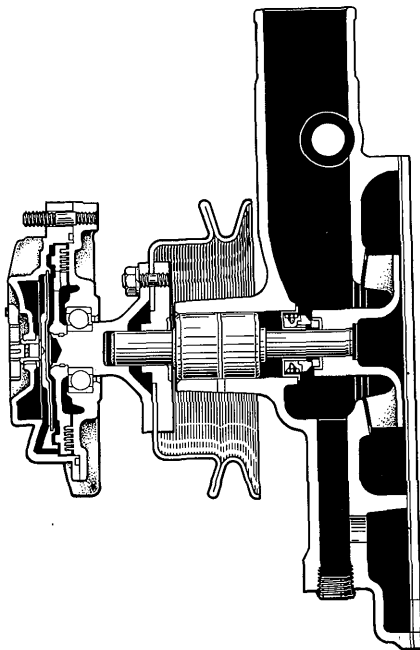

WATER PUMP

DISASSEMBLY

Disassemble the parts in the numerical order shown in the figure.

Fig. 5-3

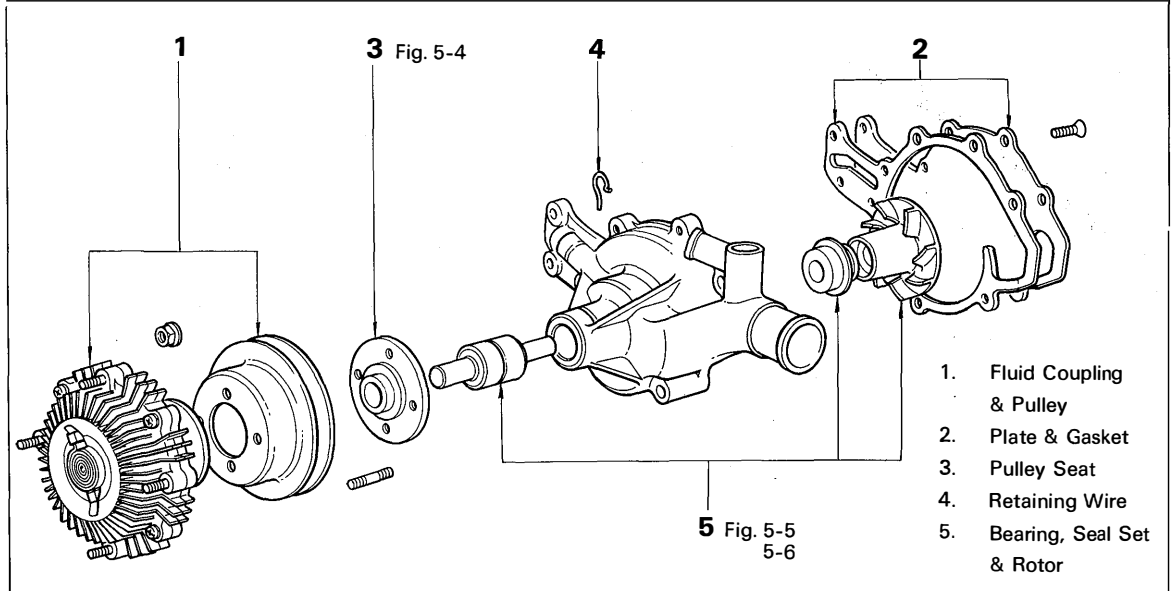
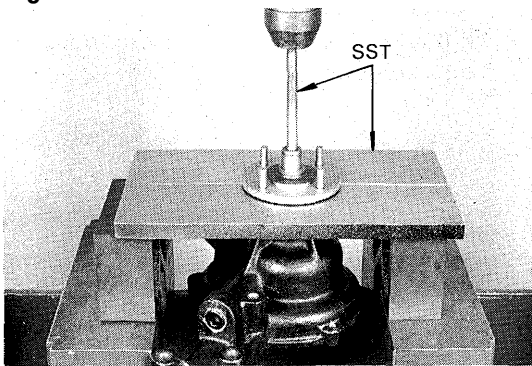

Fig. 5-4



While supporting the pulley seat, press out the shaft with SST.

SST [09236-36010]
 [09527-10010]

Fig. 5-5

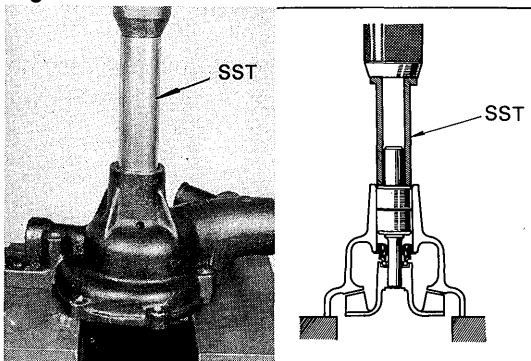

Press out the bearing together with the rotor with SST.

SST. [09236-28011] — **Bearing diameter 30 mm (1.18 in.) Type**
 [09236-36010] — **Bearing diameter 38 mm (1.50 in.) Type**

Fig. 5-6

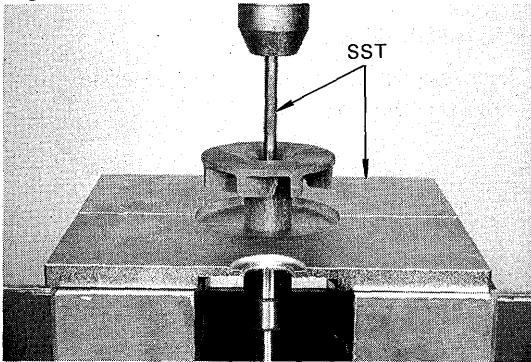

Press out the pump bearing from the rotor with SST.

SST [09236-28011]

[09236-36010]

Fig. 5-7

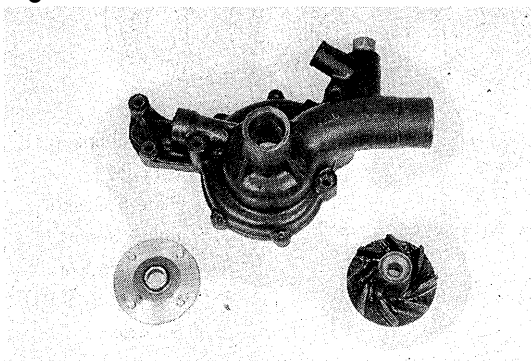

INSPECTION

1. Check the disassembled parts for cracks, wear or damage and replace if defective.

Fig. 5-8

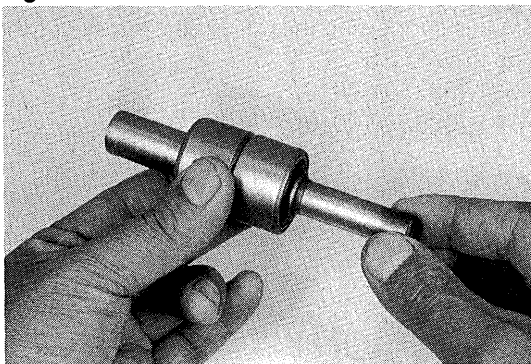

2. Check the bearing.
If it is damaged, makes noise or does not turn properly, replace.

Fig. 5-9

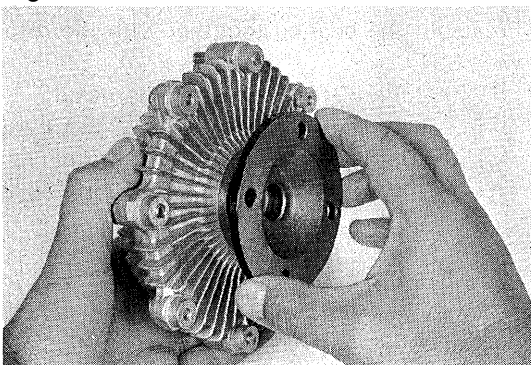

3. Check the fluid coupling for damage and leakage of silicone oil.
If necessary, replace the coupling assembly.

ASSEMBLY

Assemble the parts in the numerical order shown in the figure.

Fig. 5-10

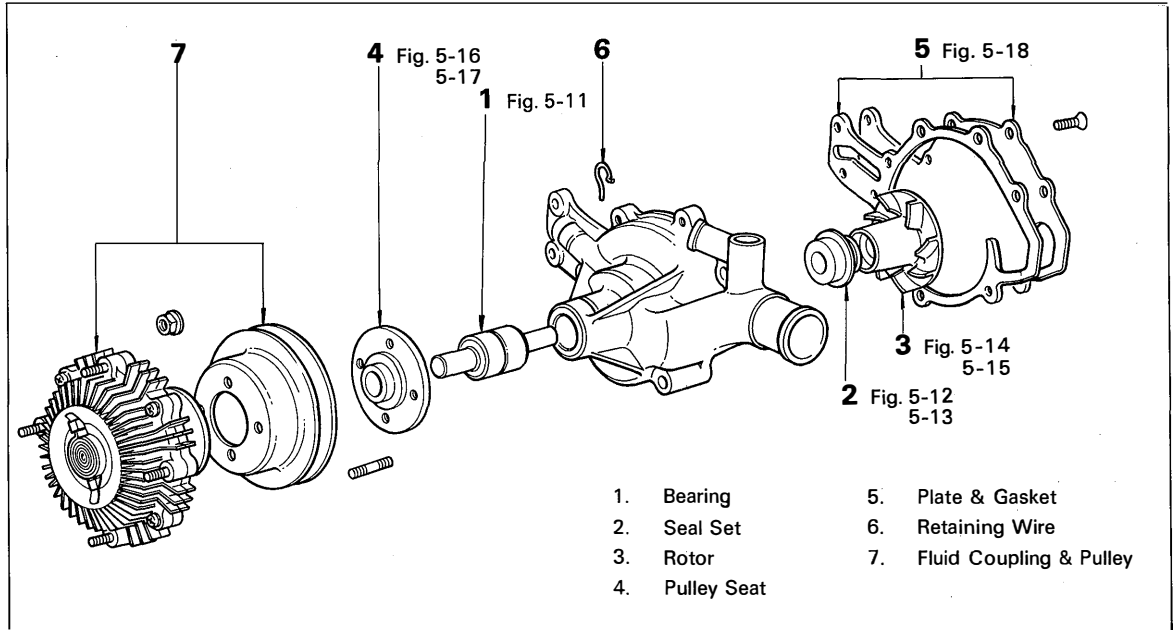
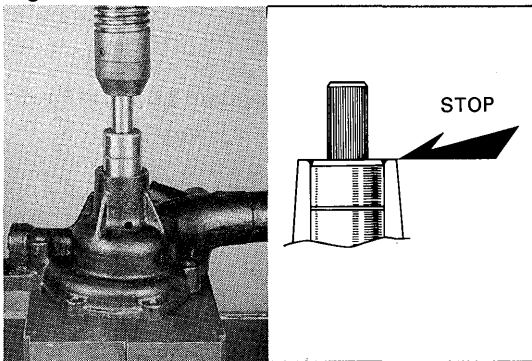

Fig. 5-11



Press in the bearing.

-Note-

The bearing end face should be flush with the body top surface.

Fig. 5-12

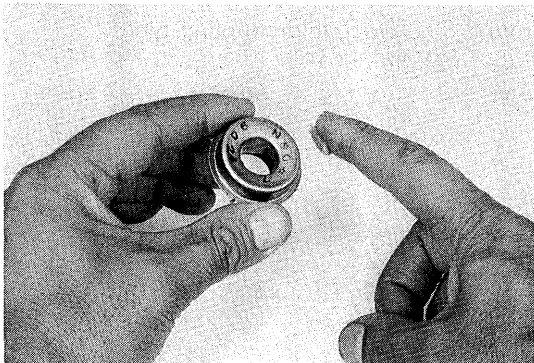

Apply a little liquid sealer to the seal.

- Note -

Always replace the seal set before reassembly.

Fig. 5-13

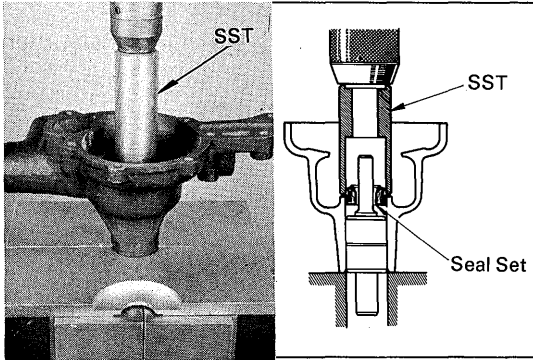

Press the seal set into the pump body with SST.

SST [09223-50010]

[09236-28011] – **Bearing diameter 38 mm (1.50 in.) Type**

[09236-36010] – **Bearing diameter 30 mm (1.18 in.) Type**

Fig. 5-14

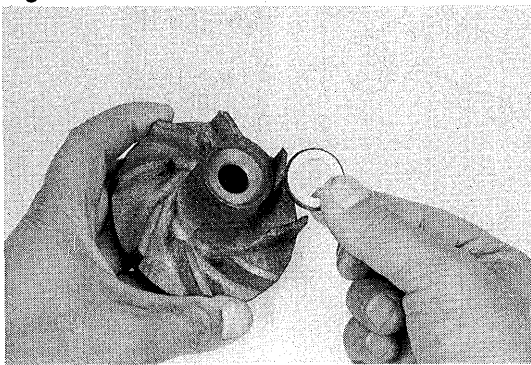

Install the seal set into the rotor.

Fig. 5-15

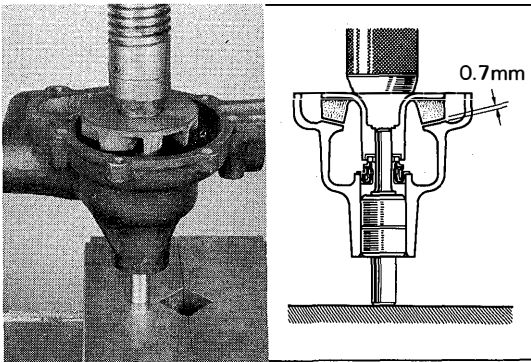

Press in the rotor.

–**Note**–

The gap between the pump body and rotor should be 0.7 mm (0.028 in.).

Fig. 5-16

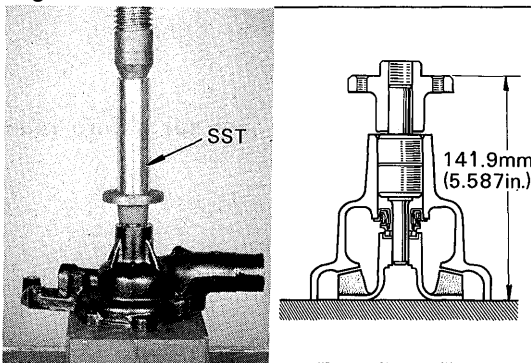

Press in the pulley seat to the specified depth with SST. (w/o fluid coupling type)

SST [09236-36010]

Fig. 5-17

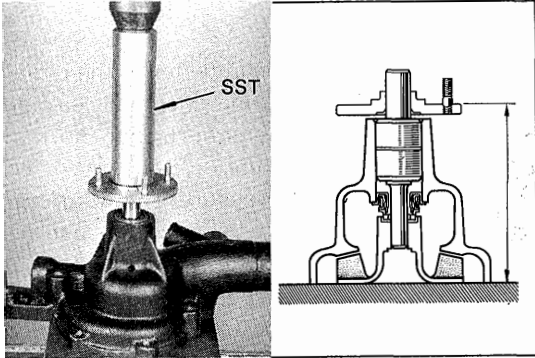

Press in the pulley seat to the specified depth with SST. (w/ fluid coupling type)
SST. [09236-36010]

Distance between pulley seat end and pump body end:

- Bearing diameter 38 mm (1.50 in.)**
- Type 134.3 mm (5.287 in.)**
- Bearing diameter 30 mm (1.18 in.)**
- Type 112.3 mm (4.421 in.)**

Fig. 5-18

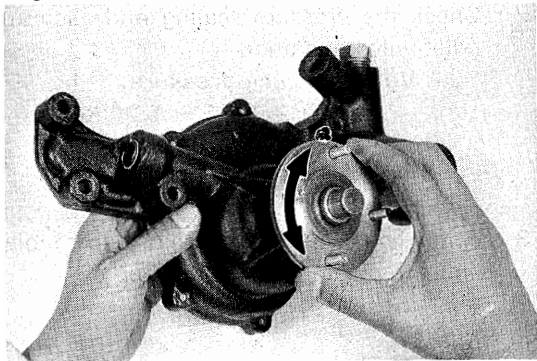

After assembly, make sure that the rotor rotates smoothly.

Fig. 5-19

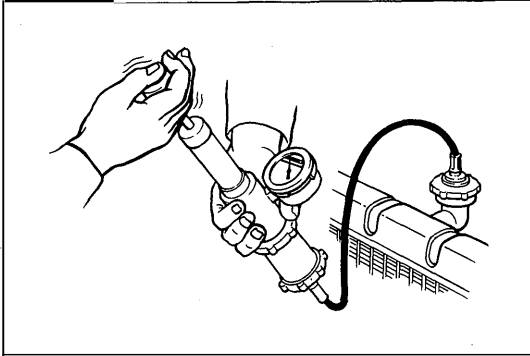

RADIATOR INSPECTION

1. Install the radiator cap tester to the radiator, apply pressure and check for leakage in the cooling system under normal operating temperature.

**Applicable pressure: 1.5 kg/cm²
(21 psi)**

Fig. 5-20

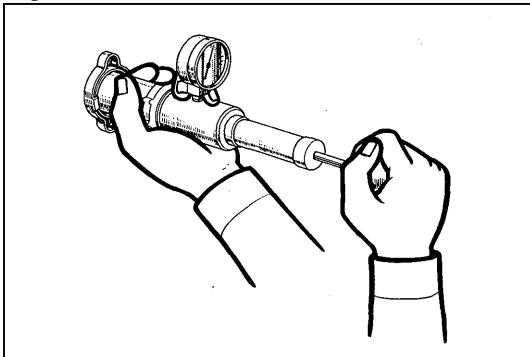

2. Check the pressure sealing and vacuum relief valve operation.

Valve opening pressure:

**STD 0.75 – 1.05 kg/cm²
(10.7 – 14.9 psi)**

**Limit 0.6 kg/cm²
(8.5 psi)**

3. If readings are not within acceptable limits, replace the radiator cap.

Fig. 5-21

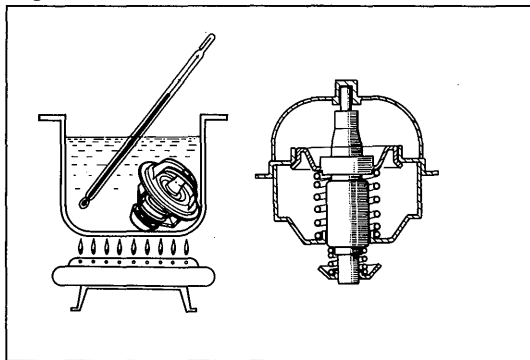

THERMOSTAT INSPECTION

1. Immerse the thermostat in water, and check the valve opening temperature by gradually heating the water.
2. Replace the thermostat if the valve remains open at normal temperature or is not very tight when fully closed.

Low temp. type:

Valve starts to open at

80.5 – 83.5°C (177 – 182°F)

Valve fully opens at

95°C (203°F)

Valve opening travel at

95°C (203°F)

10 mm (0.39 in.)

High temp. type:

Valve starts to open at

86.5 – 89.5°C (188 – 193°F)

Valve fully opens at

100°C (212°F)

Valve opening travel at

100°C (212°F)

10 mm (0.39 in.)

Fig. 5-22

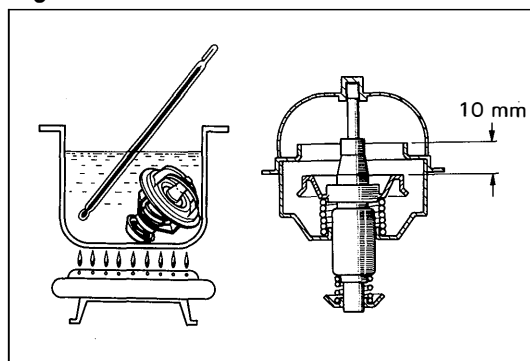

FUEL SYSTEM

	Page
FUEL SYSTEM CIRCUIT	6-2
FUEL FILTER	6-3
SEDIMENTER	6-8
INJECTION NOZZLE	6-9
FUEL FEED PUMP	6-17
AUTOMATIC TIMER	6-22
INJECTION PUMP	6-29

FUEL SYSTEM CIRCUIT

Fig. 6-1

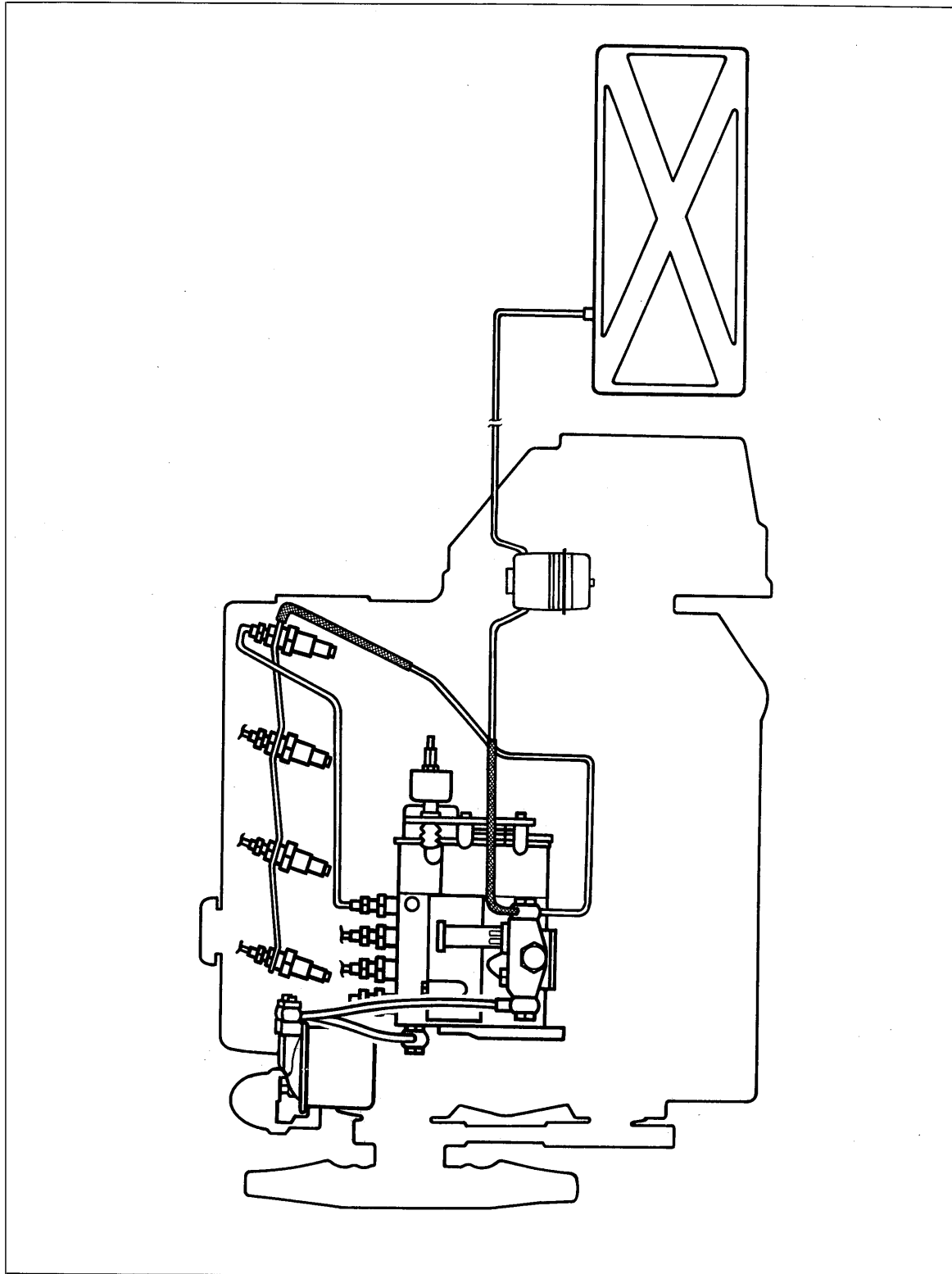

FUEL FILTER

CARTRIDGE TYPE

DISASSEMBLY

Disassemble the parts in the numerical order shown in the figure.

Fig. 6-2

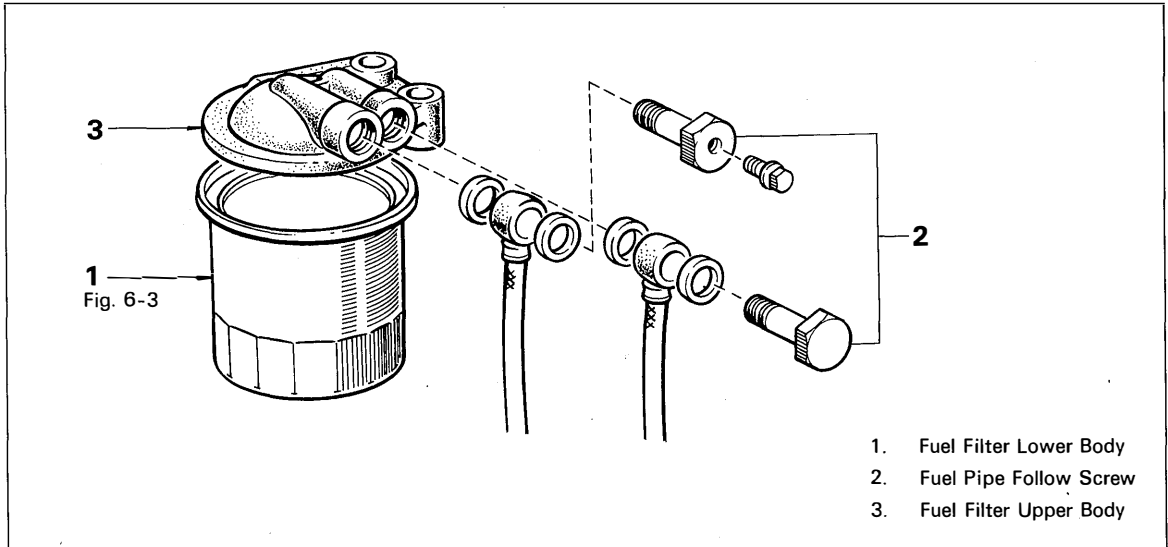
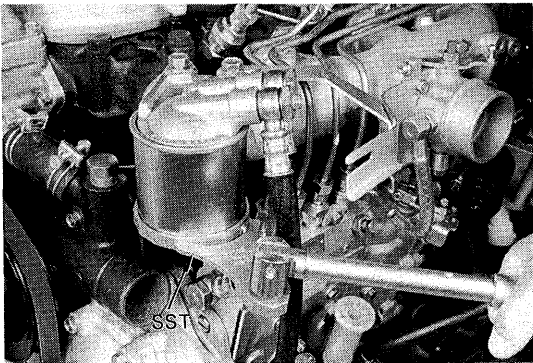
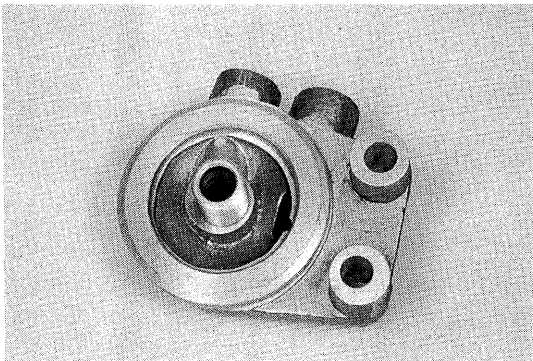

Fig. 6-3



Remove the fuel filter with SST.
SST [09228-34010]

Fig. 6-4



INSPECTION

Check the connecting surface for scoring or cracks.

ASSEMBLY

Assemble the parts in the numerical order shown in the figure.

Fig. 6-5

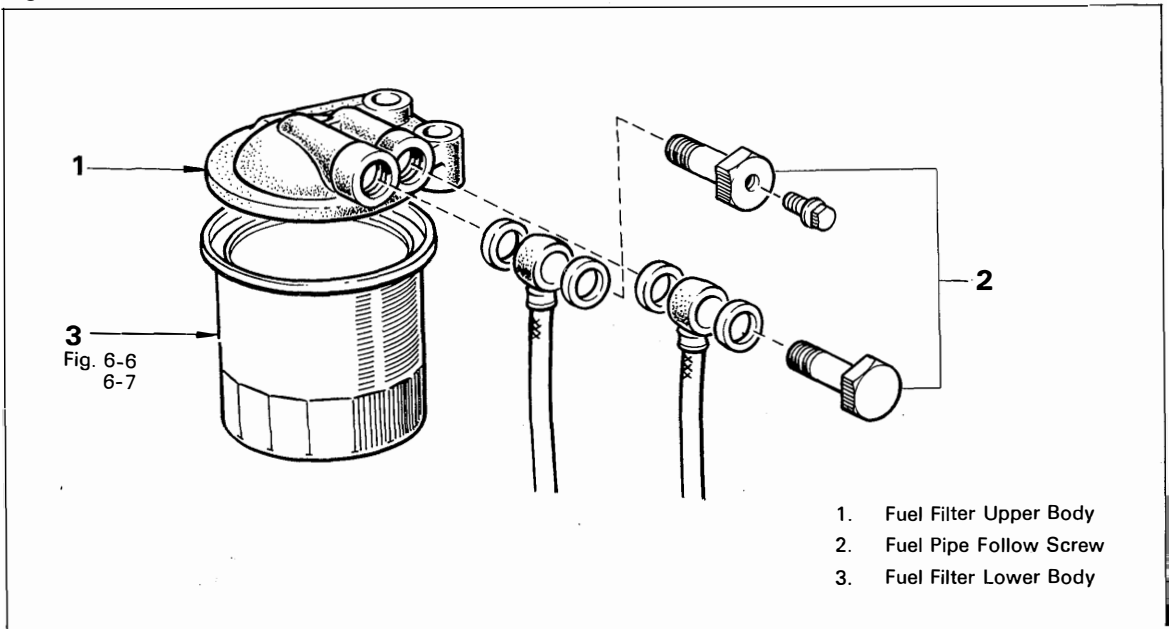
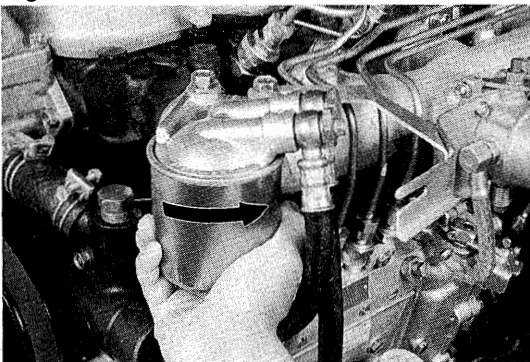

Fig. 6-6



Install the fuel filter by hand.

-Note-

Do not use SST to install the filter.

Fig. 6-7

SEE
INJECTION PUMP
INSTALLATION
SECTION
Fig. 6-212 to 6-217

After installing, bleed air from fuel filter.

ELEMENT TYPE

DISASSEMBLY

Disassemble the parts in the numerical order shown in the figure.

Fig. 6-8

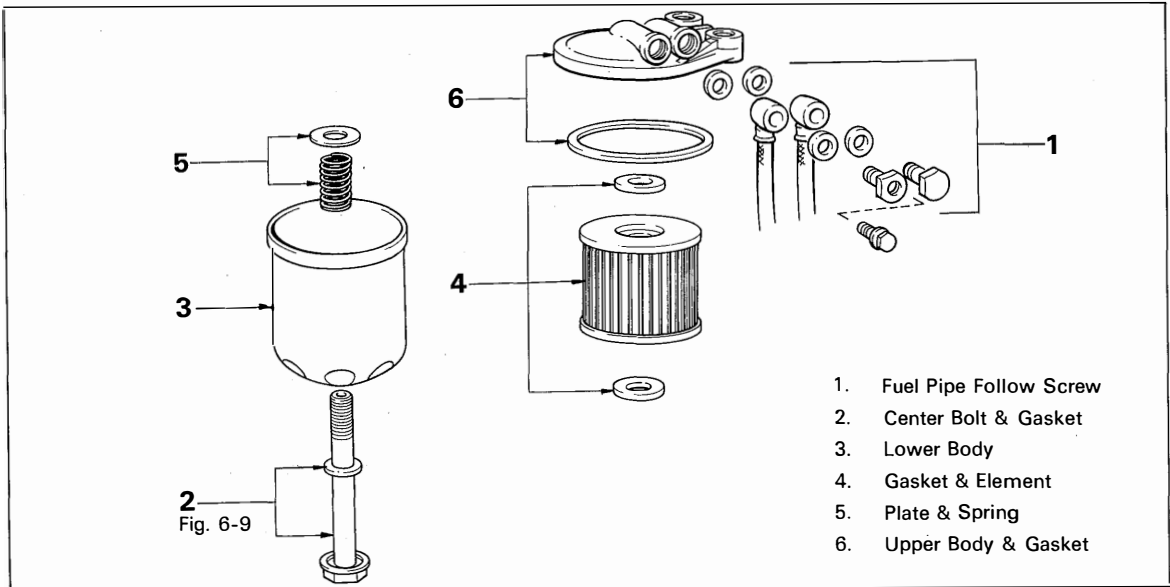
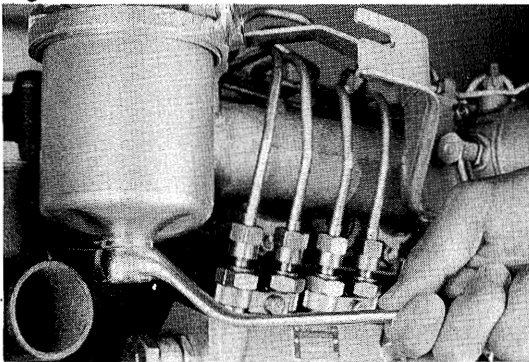
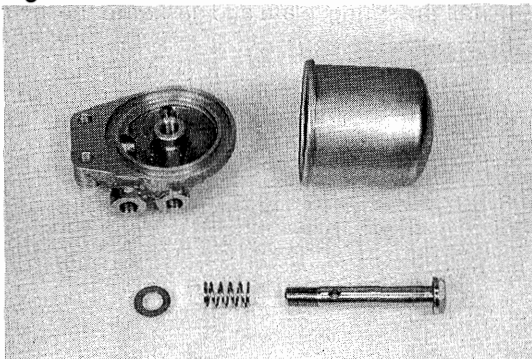

Fig. 6-9



Loosen the bolt and take off the lower body.

Fig. 6-10



INSPECTION

Clean all disassembled parts.
 Check the disassembled parts for wear or damage.

ASSEMBLY

Assemble the parts in the numerical order shown in the figure.

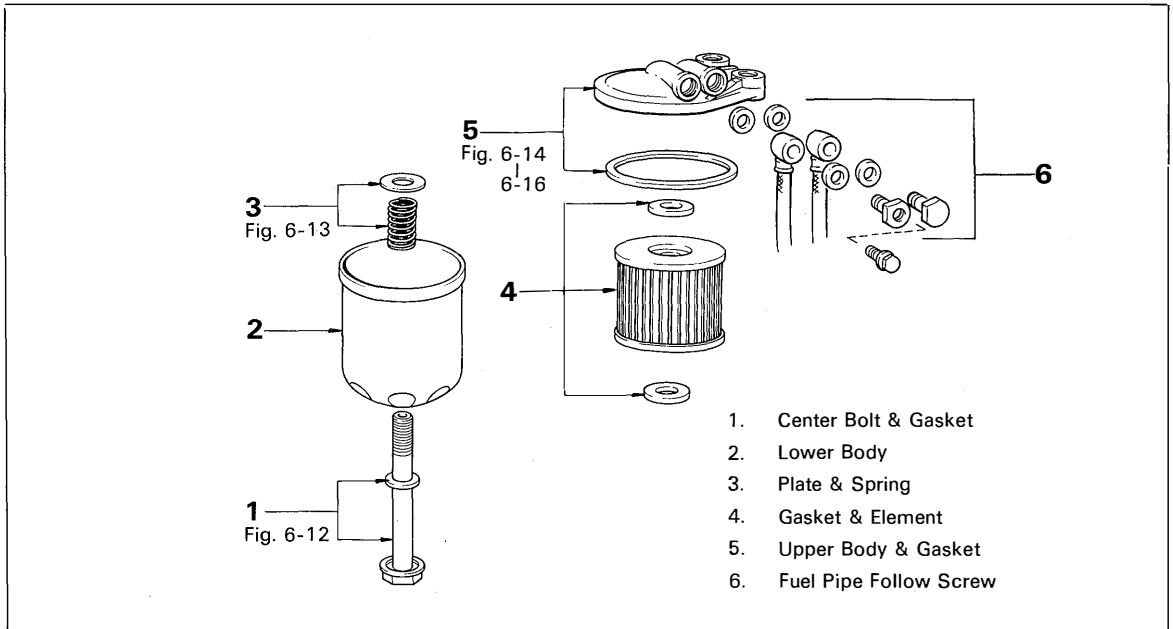
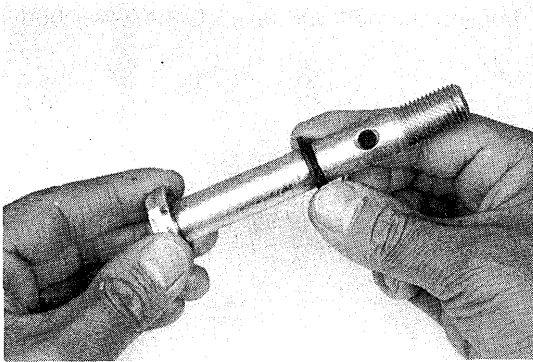
Fig. 6-11**Fig. 6-12**

Install an O ring facing its flat side toward the bolt head.

—Note—

Use a new gasket.

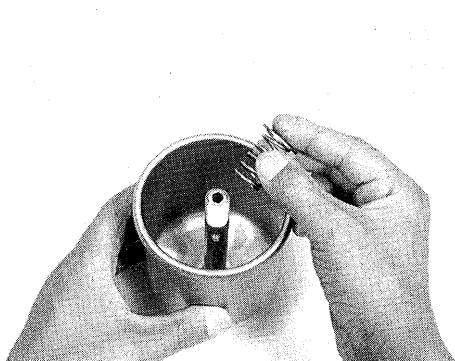
Fig. 6-13

Install the spring, plate and gasket to the lower body.

Fig. 6-14

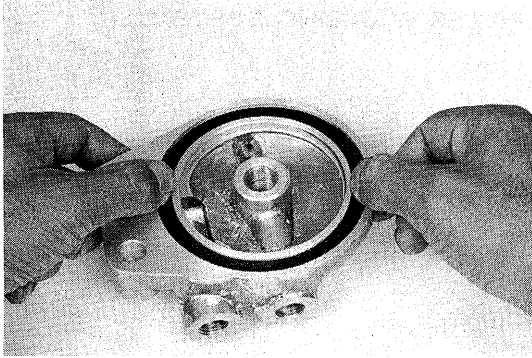

Install the gasket.

Fig. 6-15

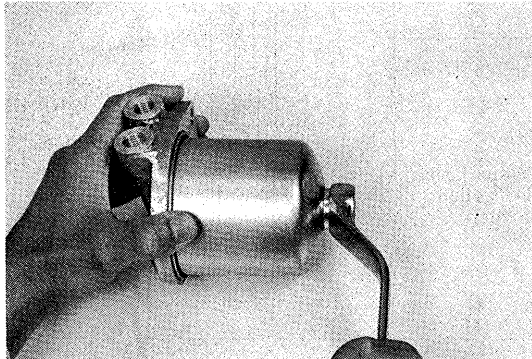

Assemble the lower body and tighten the bolt.

Fig. 6-16

**SEE
INJECTION PUMP
INSTALLATION
SECTION
Fig. 6-218 to 6-223**

After installing, bleed air from fuel filter.

SEDIMENTER FILTER WARNING SYSTEM

Fig. 6-17

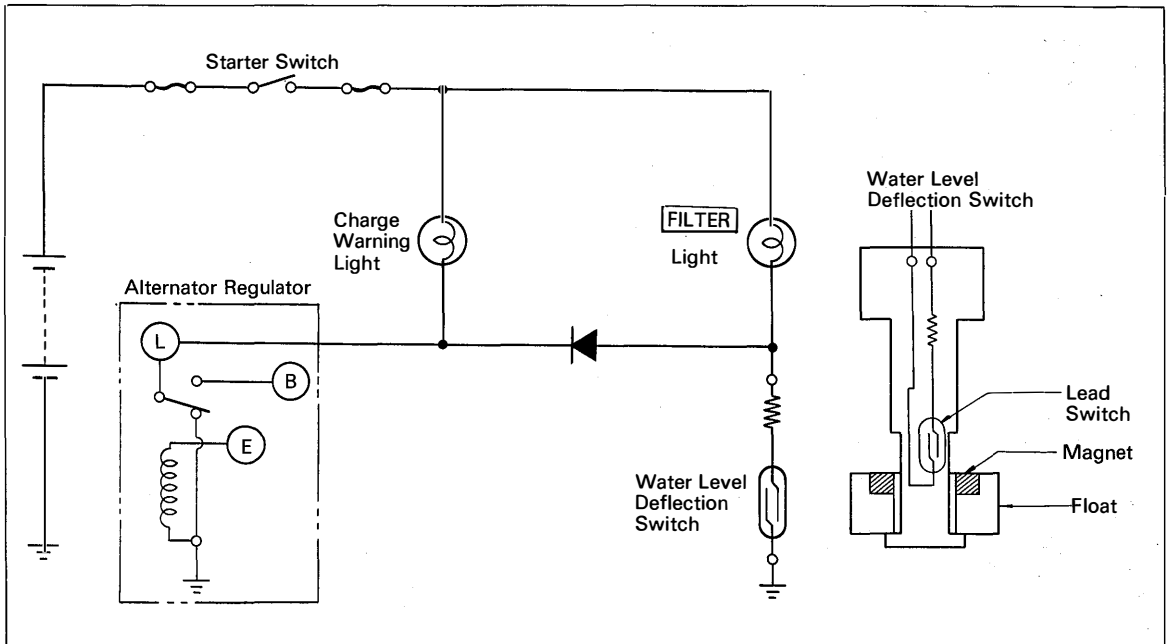
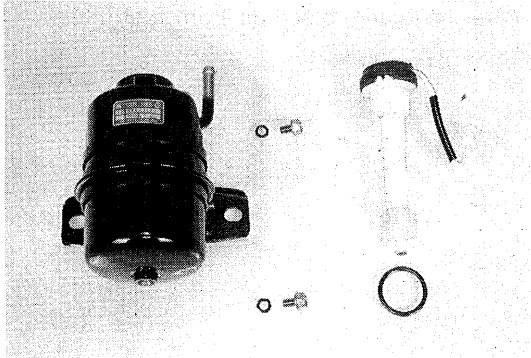

Fig. 6-18



INSPECTION

Check each part for damage, cracks or deformation.

-Note-

When assembling, be sure to replace the oil seal with new one.

Fig. 6-19

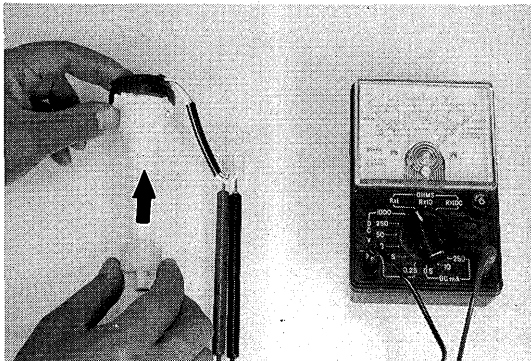

Check the level warning switch.

Connect a circuit tester to the switch connector and check the conductivity when the float is raised.

INJECTION NOZZLE

REMOVAL

Remove the parts in the numerical order shown in the figure.

Fig. 6-20

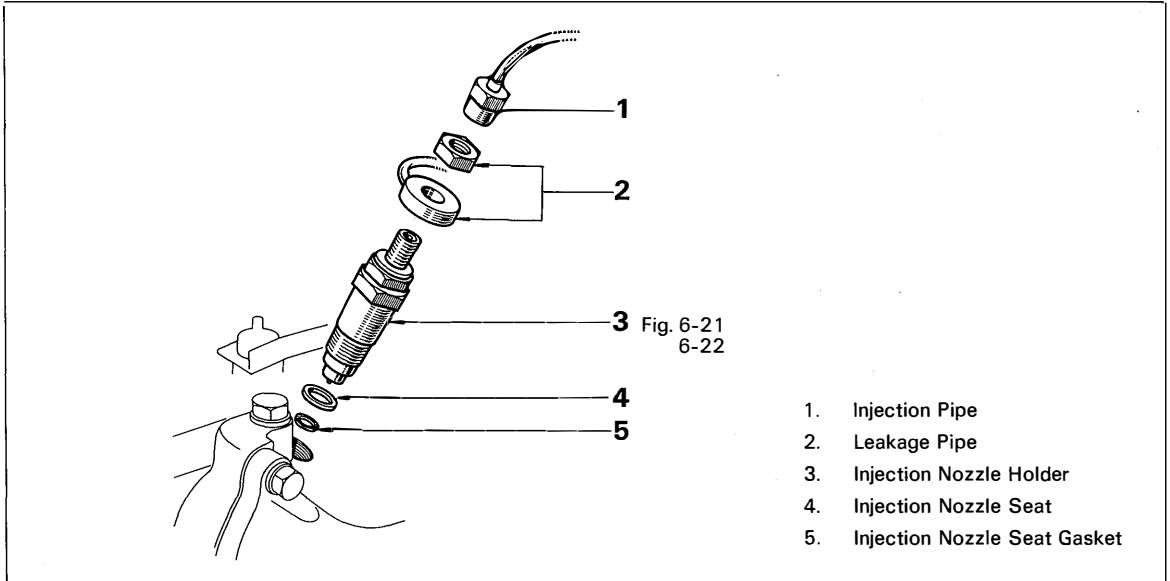
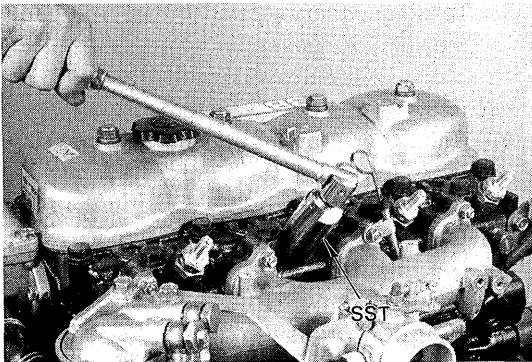
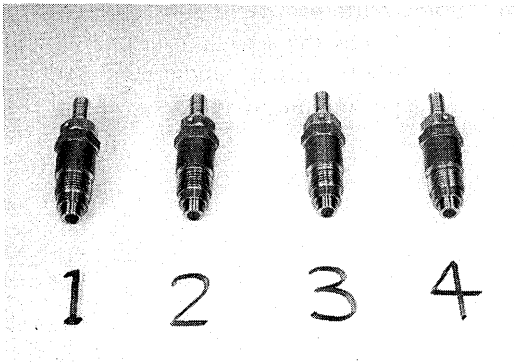

Fig. 6-21



Remove the injection nozzle holders with SST. SST (09268-46011) of set [09260-46011]

Fig. 6-22



Arrange the injection nozzle holders in correct order to facilitate reassembly.

Fig. 6-23

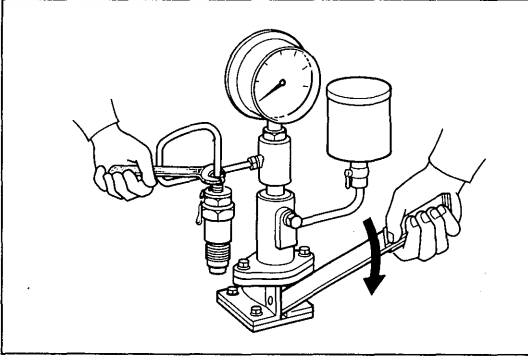

Fig. 6-24

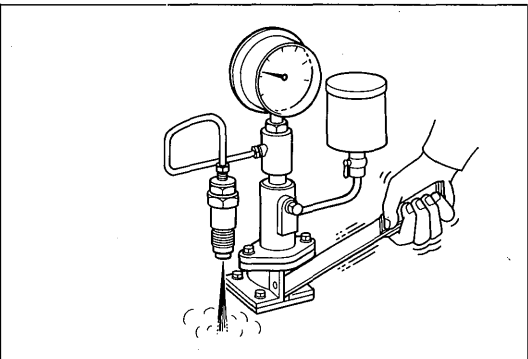

Fig. 6-25

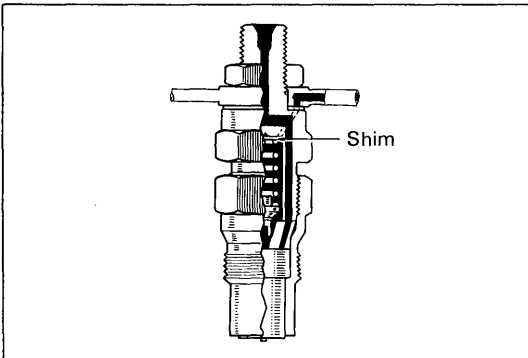
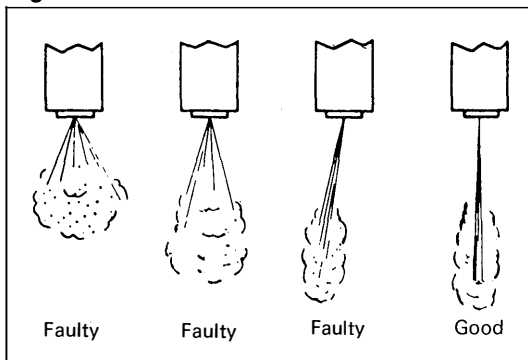

Fig. 6-26



SPRAY TEST

1. Install the nozzle to the injection nozzle hand tester and bleed air from the union nut.
2. Injection pressure.
 - (1) Pump the tester handle 50 – 60 times per minute by hand.
 - (2) Read the injection starting pressure.

Opening pressure:

New nozzle

115 – 125 kg/cm²
(1,636 – 1,778 psi)

Reused nozzle

105 – 125 kg/cm²
(1,493 – 1,778 psi)

—Note—

1. Proper nozzle operation can be determined by a hissing sound.
2. Adjust the injection starting pressure to 110 – 125 kg/cm² (1,565 – 1,778 psi), if the reused nozzle has been overhauled.
3. To adjust the injection pressure, change the shim on the top of the pressure spring.

—Note—

1. Shims are available in 20 sizes, in increments of 0.05 mm (0.0020 in.), from 1.00 – 1.95 mm (0.0394 – 0.0768 in.)
2. Varying the adjusting shim thickness by 0.05 mm (0.0020 in.) changes the injection pressure by about 5 kg/cm² (71 psi).



4. Spray patterns.
 - (1) Check the spray patterns, by pumping the tester handle 50 – 60 times per minute by hand.

Fig. 6-27

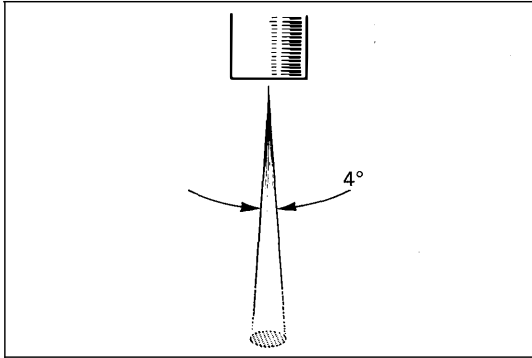

- (2) Spray should spread evenly down the nozzle center line in a 4° conical form.
- (3) Place a white sheet of paper about 30 cm (11.8 in.) away from the nozzle to check if spray pattern is in circular form.

Fig. 6-28

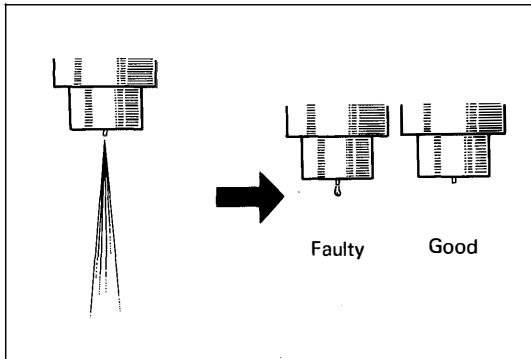

5. There should be no dripping after injection.

Fig. 6-29

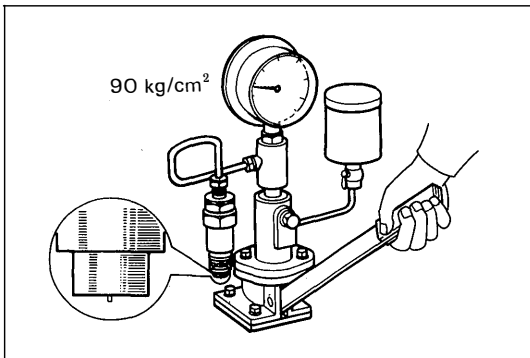

6. Leakage test.
Apply 90 kg/cm² (1,280 psi) of fuel pressure, and check for leaks at nozzle valve seat and retaining nut.

DISASSEMBLY

Disassemble the parts in the numerical order shown in the figure.

Fig. 6-30

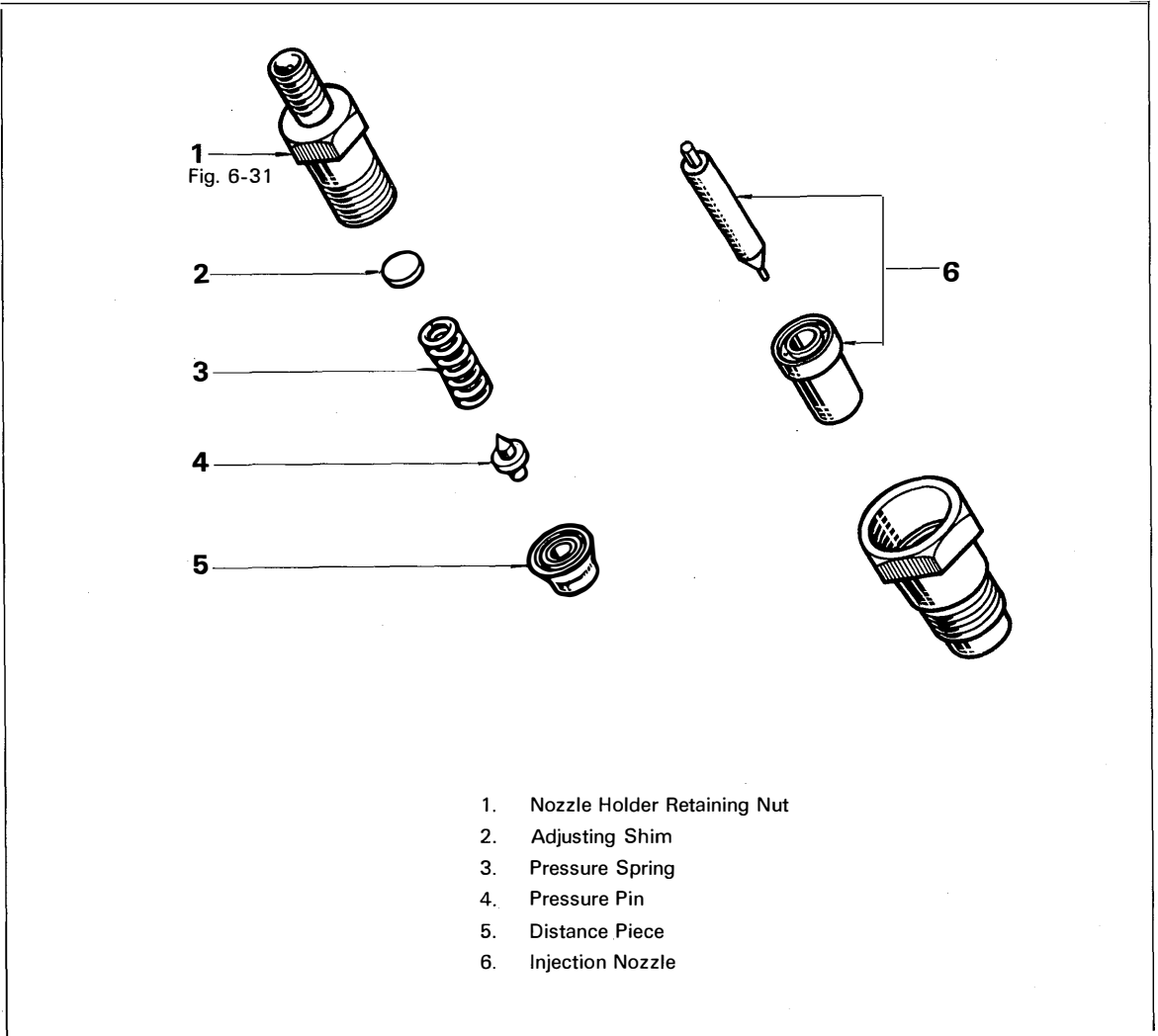

1. Nozzle Holder Retaining Nut
2. Adjusting Shim
3. Pressure Spring
4. Pressure Pin
5. Distance Piece
6. Injection Nozzle

Fig. 6-31

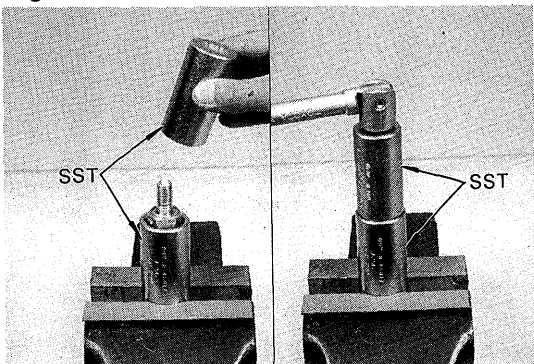

Unscrew the nozzle holder retaining nut with SST.

SST (09268-46011) & (09268-46021) of set [09260-46011]

Fig. 6-32

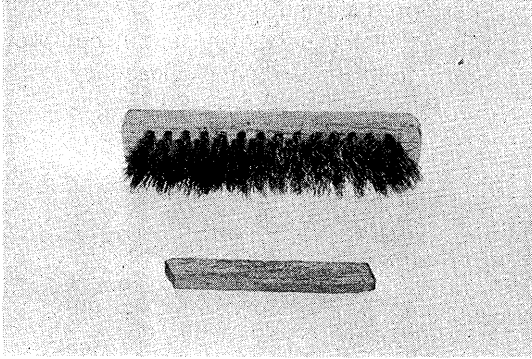

Fig. 6-33

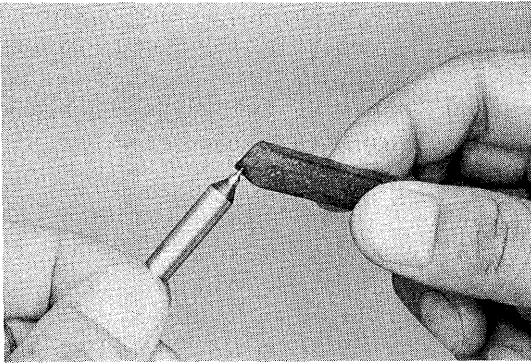

Fig. 6-34

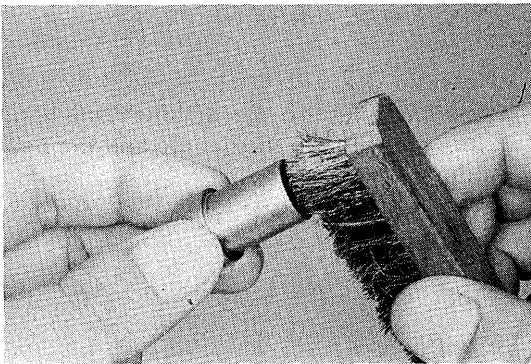
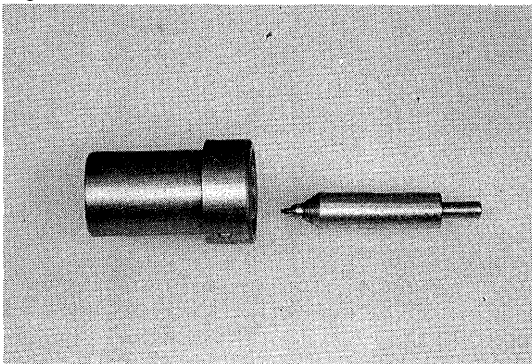

Fig. 6-35



NOZZLE CLEANING



1. To wash the nozzles, use a wooden stick and brass brush. Wash in clean diesel fuel or light oil.

2. Remove the carbon adhering to the nozzle needle tip with a wooden stick.

3. Remove the carbon from the exterior of the nozzle body (except wrapping angle) with a brass brush.

4. Wash the nozzle in clean diesel fuel or light oil.

Fig. 6-36

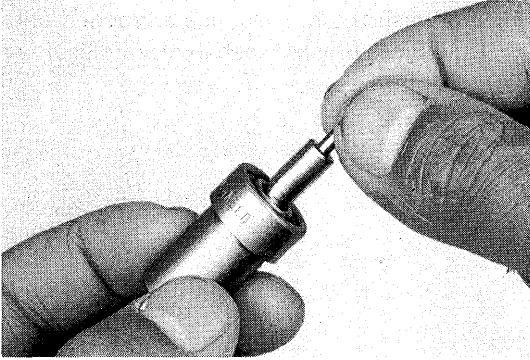

Fig. 6-37

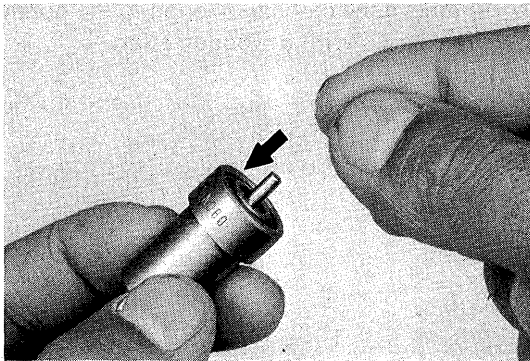
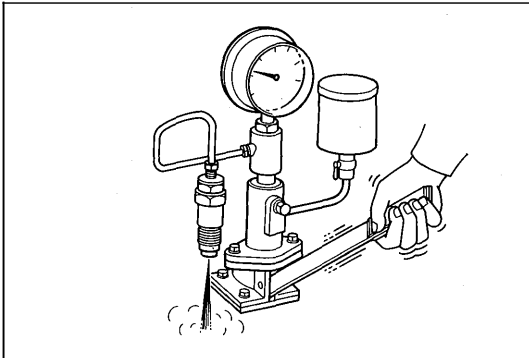

Fig. 6-38



5. Perform a sinking test.
 - (1) Pull the needle out about half way from the body and release it.
 - (2) The needle should sink down into the body vent smoothly by its own weight.
 - (3) Repeat this test, rotating the needle slightly each time.

6. Perform a spray test.

—Note—

If the nozzle fails the sinking and spray tests, replace both the needle and the body as a unit.

ASSEMBLY

Assemble the parts in the numerical order shown in the figure.

Fig. 6-39

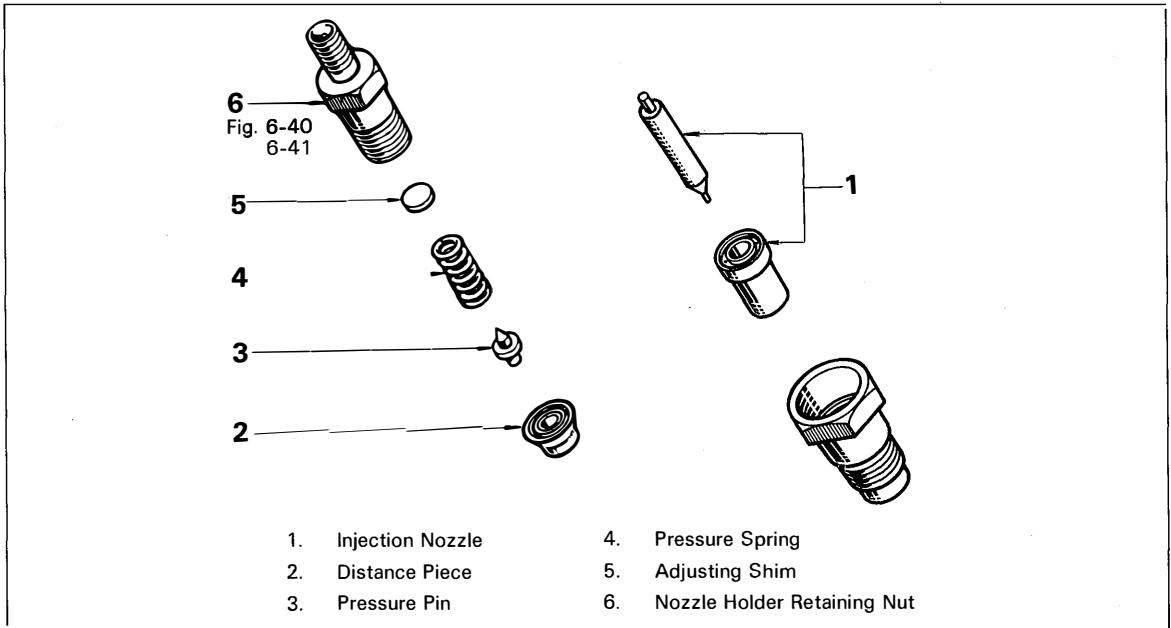
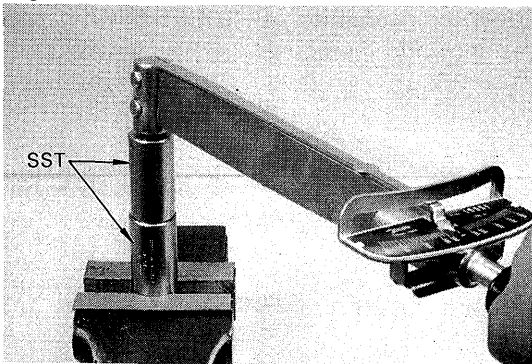

Fig. 6-40



Tighten the retaining nut with SST.

SST (09268-46011) &

(09268-46021) of set [09260-46011]

**Tightening torque: 5.0 — 7.0 kg-m
(37 — 50 ft-lb)**

Fig. 6-41

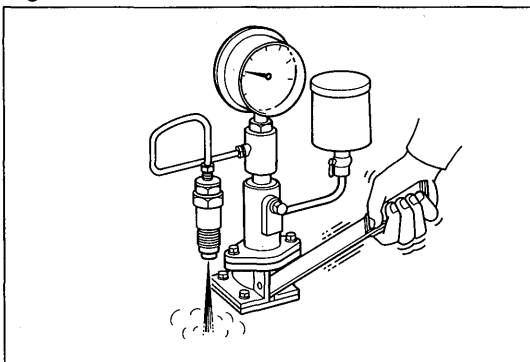

After assembling the injection nozzle, perform a spray test and adjust if necessary.



INSTALLATION

Install the parts in the numerical order shown in the figure.

Fig. 6-42

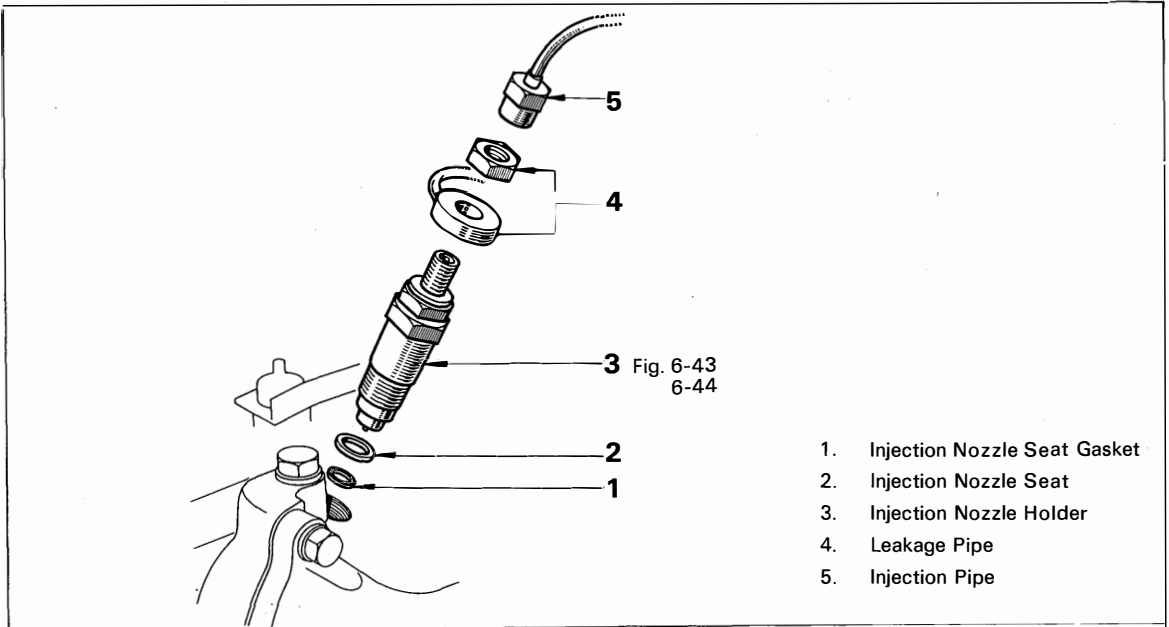
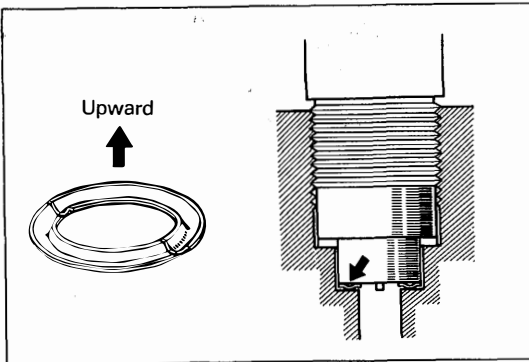
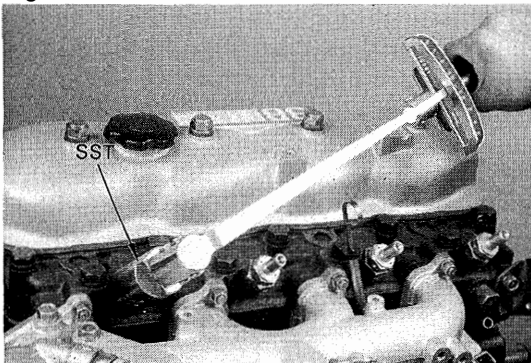

Fig. 6-43



Note the orientation of the nozzle seat gasket as shown in the figure.

Fig. 6-44



Tighten the nozzle holder with SST. SST (09268-46011) of set [09260-46011]

**Tightening torque: 6.0 – 8.0 kg-m
(44 – 57 ft-lb)**

–Note–

After installing, bleed the air.

FUEL FEED PUMP CUTAWAY VIEW

Fig. 6-45

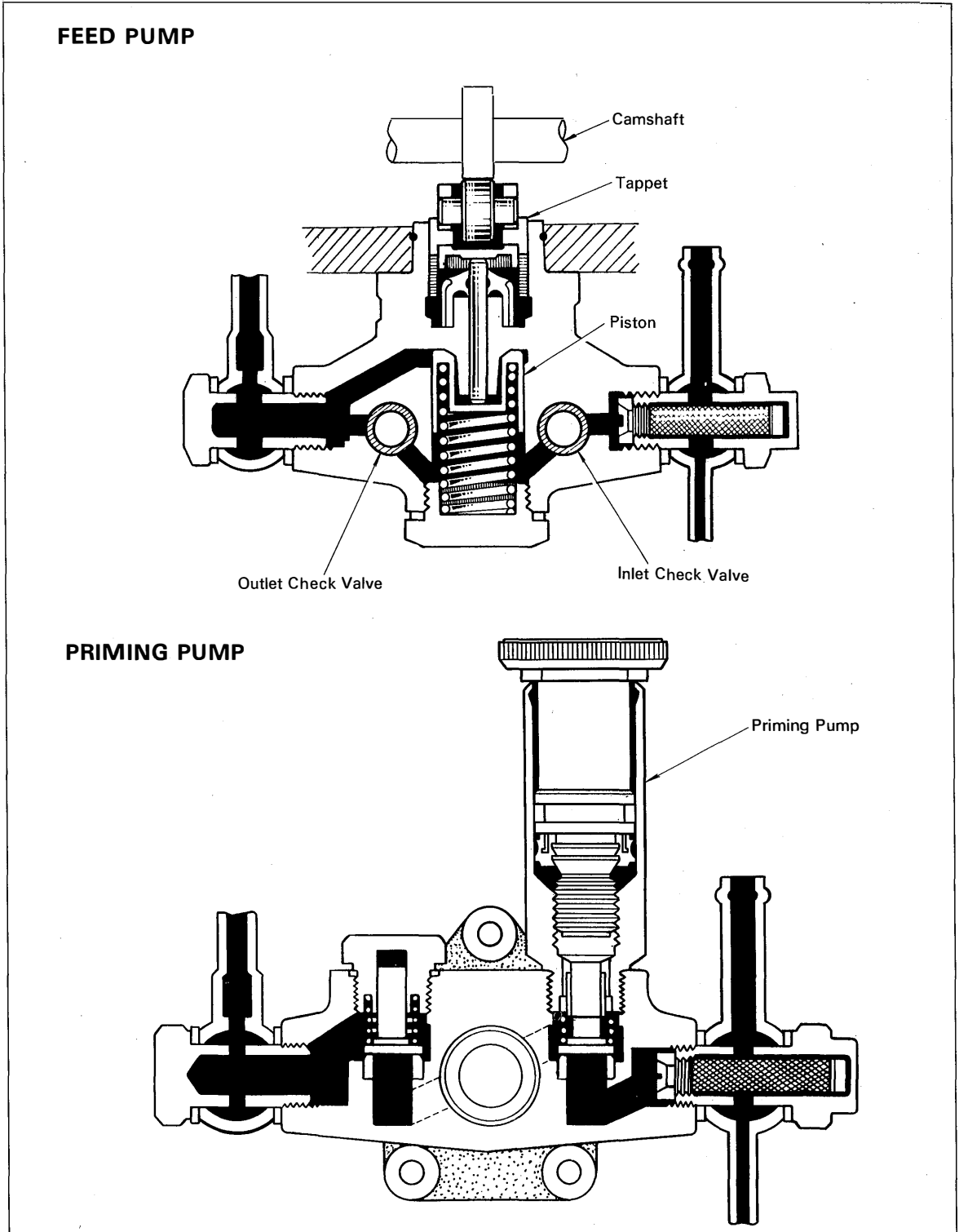
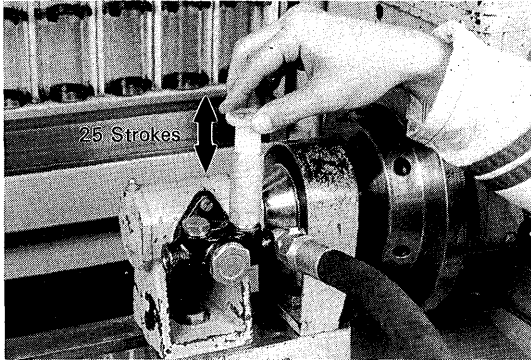

Fig. 6-46

**FEED PUMP TEST**

1. Suction capacity test

The size of the suction pipes should be:

Pipe inner diameter:

8 mm (0.31 in.)

Pipe length: 2 m (78.7 in.)

Suction height: 1 m (39.4 in.)

- (1) Operate the priming pump for one minute at 60 strokes per minute.

Suction capacity

Fuel must discharge within:

25 strokes

- (2) Set the feed pump tester at 150 rpm and test the feed pump suction capacity.

Suction capacity

Fuel must discharge within:

40 seconds

Fig. 6-47

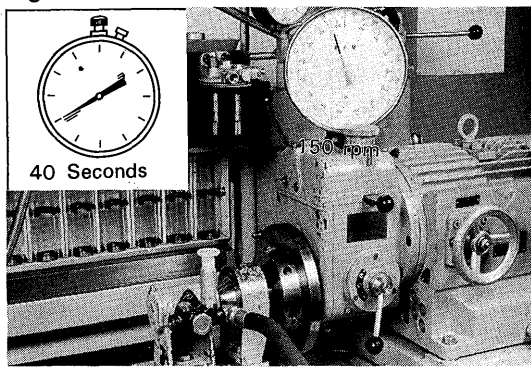
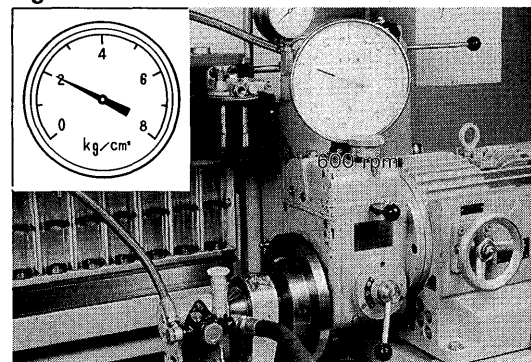

Fig. 6-48



2. Discharge performance test

Connect the pressure gauge to the feed pump discharge side.

- (1) Operate the feed pump at 600 rpm.

Discharge pressure:

1.8 – 2.2 kg/cm²

(26 – 31 psi)

Fig. 6-49

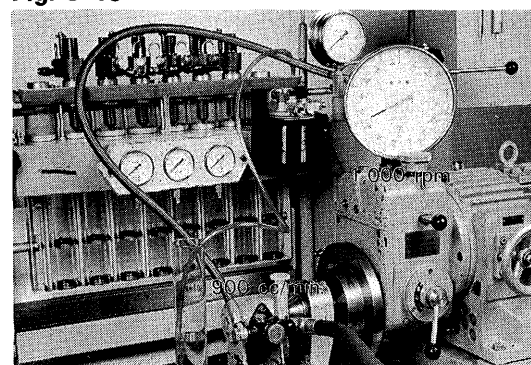

- (2) Operate the feed pump at 1,000 rpm. Measure discharge volume from the discharge side nozzle.

Discharge side nozzle diameter:

1.54 mm

(0.0606 in.)

Discharge volume capacity:

More than 900 cc/min.

(54.9 cu in.)

DISASSEMBLY

Disassemble the parts in the numerical order shown in the figure.

Fig. 6-50

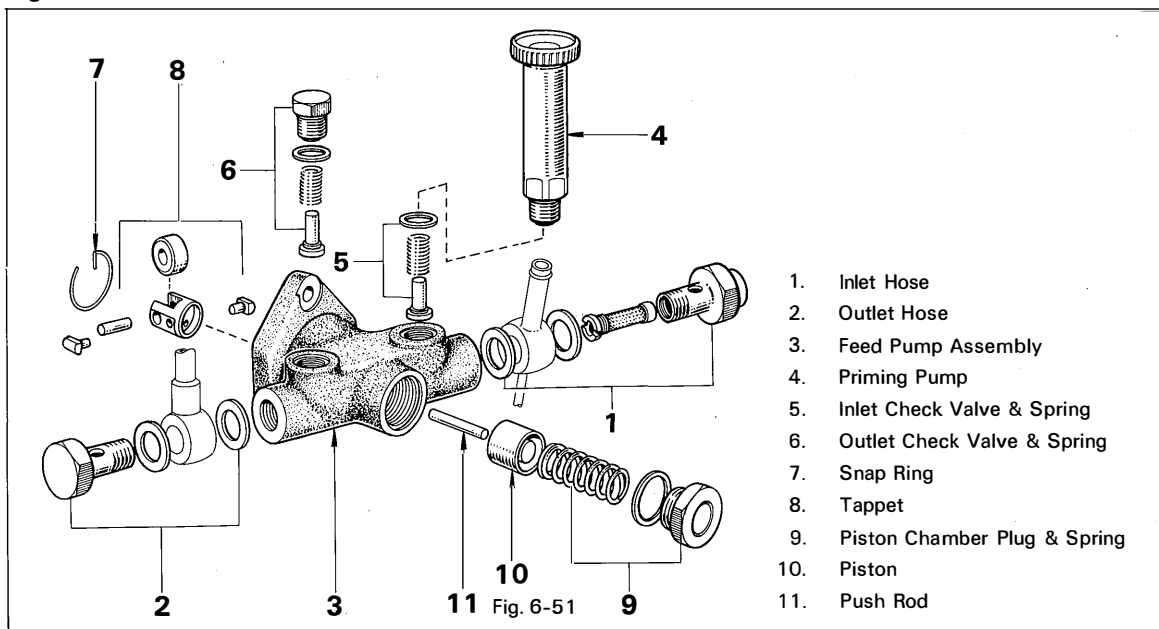
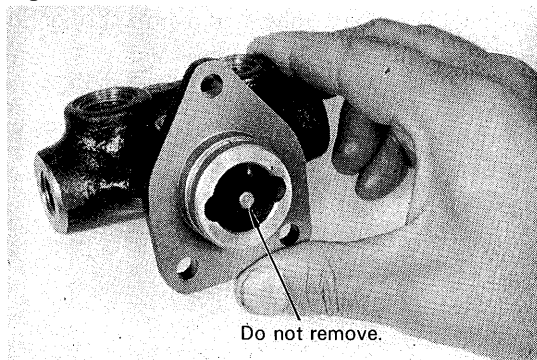
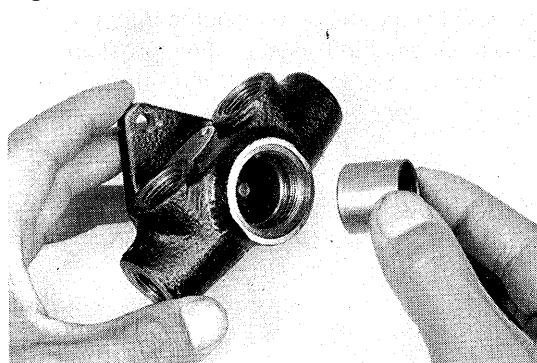

Fig. 6-51



Since the push rod is precisely fitted into the feed pump housing, do not remove the rod unless necessary. If removed, be sure to confirm assembly direction.

Fig. 6-52



INSPECTION



Inspect the piston, push rod and feed pump housing for wear or damage.

Clearance (Reference):

STD Piston

0.009 – 0.013 mm
(0.0004 – 0.0005 in.)

Push rod

0.003 – 0.006 mm
(0.0001 – 0.0002 in.)

Fig. 6-53

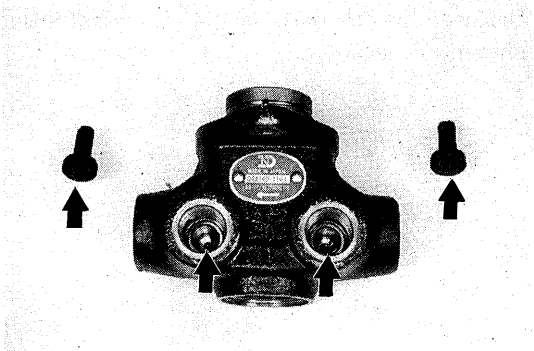

Inspect the check valve and valve seat for wear or damage.

Fig. 6-54

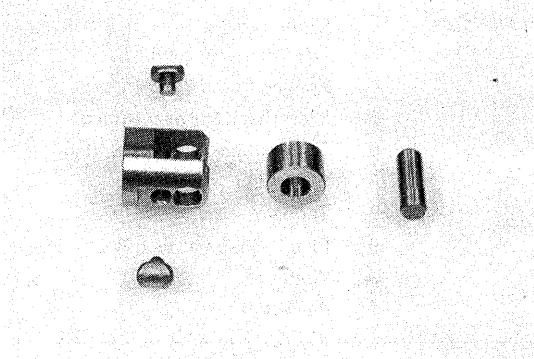

Inspect the tappet and roller for wear or damage.

Fig. 6-55

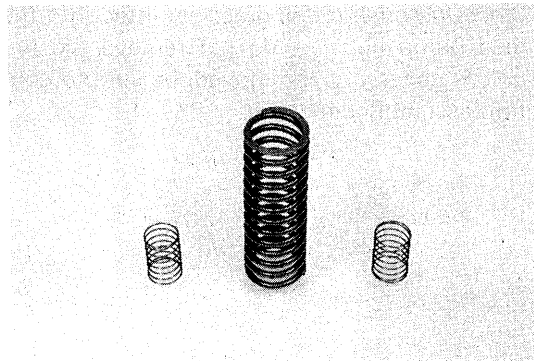

Inspect the check valve and piston springs for wear or damage.

Fig. 6-56

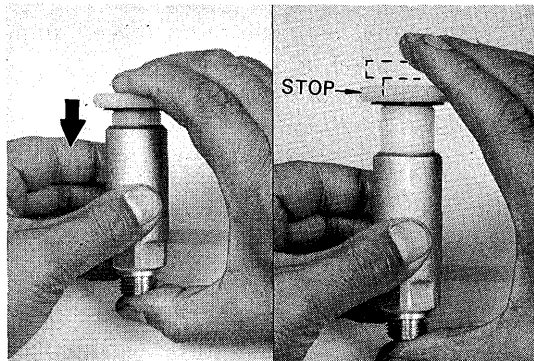

Strongly plug the priming pump inlet port with your finger and check that pressure and vacuum are created when the pump is operated.

ASSEMBLY

Assemble the parts in the numerical order shown in the figure.

Fig. 6-57

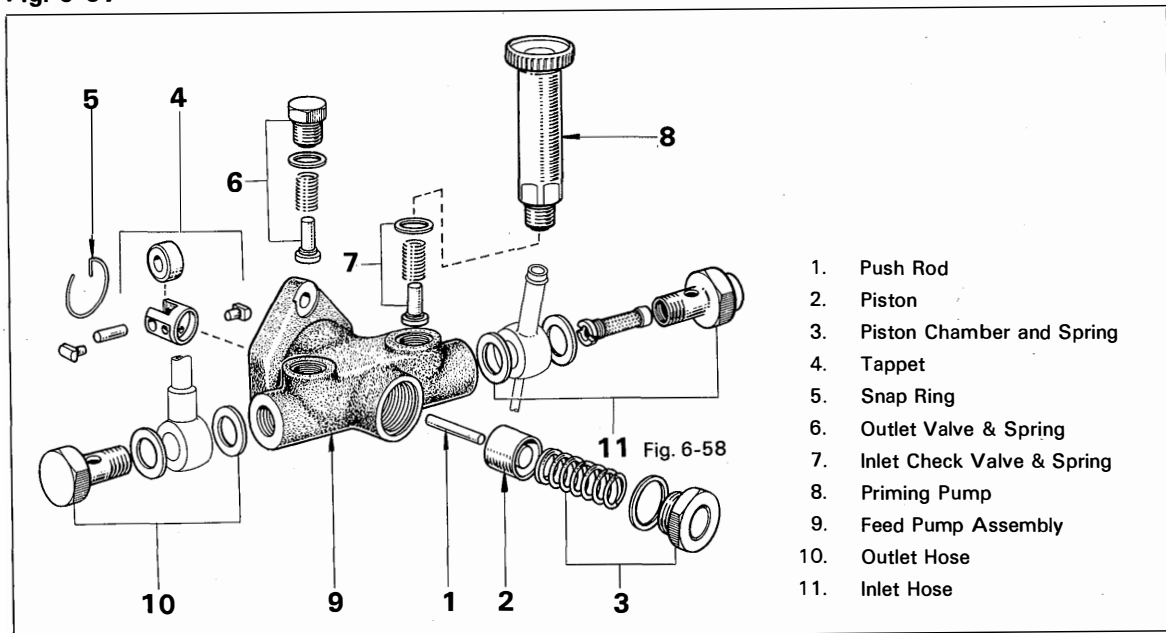
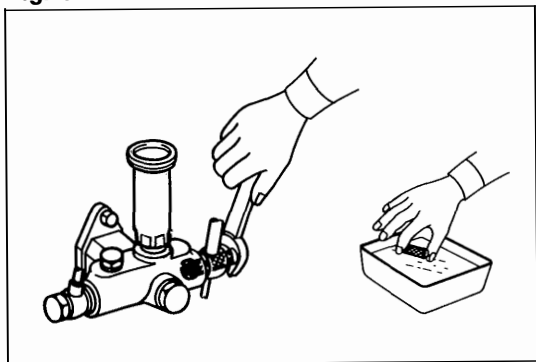

Fig. 6-58



Before assembling, clean the filter inside the union bolt.

AUTOMATIC TIMER

REMOVAL

Remove the parts in the numerical order shown in the figure.

Fig. 6-59

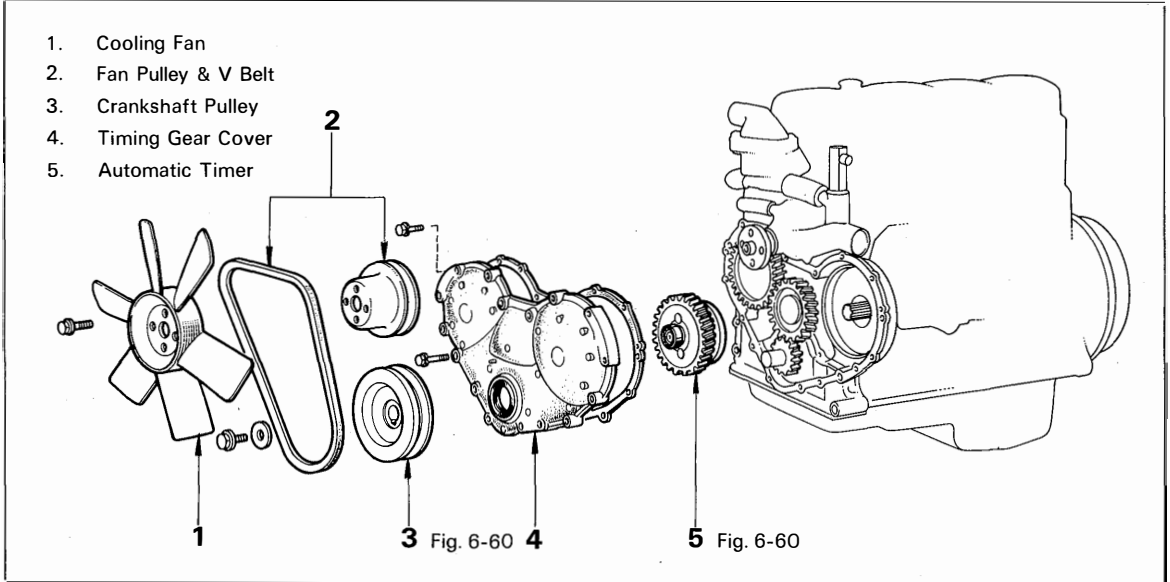
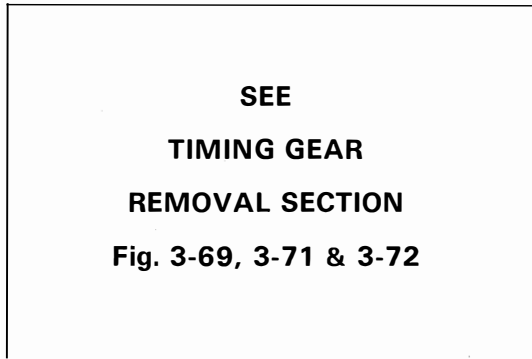
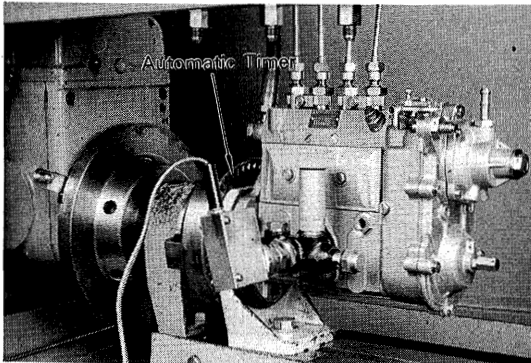

Fig. 6-60



Remove the automatic timer.

Fig. 6-61



INSPECT ADVANCE ANGLE



1. Install the automatic timer on the pump spline shaft and mount the injection pump on the pump tester.
2. Fill the pump camshaft chamber with engine oil.

Fig. 6-62

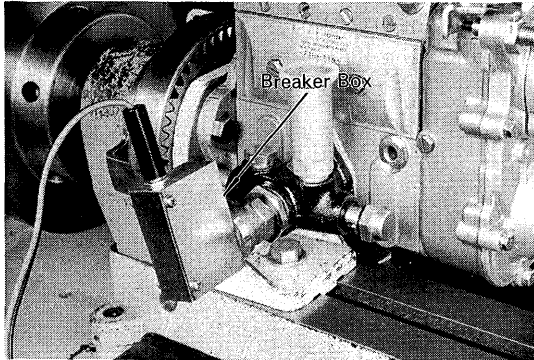

Fig. 6-63

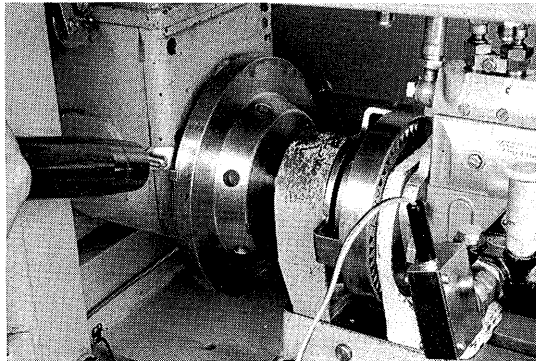

Fig. 6-64

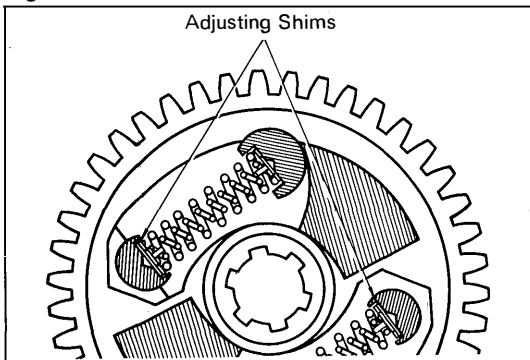
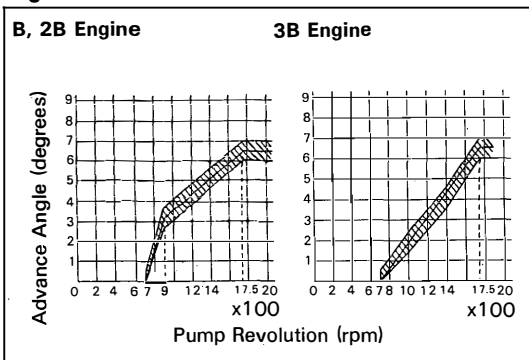

Fig. 6-65



- Using an adapter, install the timer breaker box to the piston bore of the feed pump.

- Using the timing light, check advance angle.

Pump (rpm)	Timer advance angle	
	B, 2B	3B
700	Advance begins ($\leq 0.5^\circ$)	Advance begins ($\leq 0.5^\circ$)
900	2.7 - 3.7°	—
1,000	—	1.3 - 2.3°
1,100	3.5 - 4.5°	—
1,400	—	3.7 - 4.7°
1,450	4.8 - 5.8°	—
1,750	6.0 - 7.0°	6.0 - 7.0°
1,850	6.0 - 7.0°	—
1,900	—	6.0 - 7.0°

- If the advance angle is not within specified range, adjust by changing the inner and outer timer spring shims.

-Note-

- The inner spring is not equipped with the automatic timer on 3B engines.
- Use outer spring shim to adjust the timing advance characteristics in low speed range, and inner spring shim in high speed range.

Outer adjusting shim thickness:
0.1, 0.2, 0.5 mm
(0.004, 0.008, 0.020 in.)

Inner adjusting shim thickness:
0.1, 0.2, 0.5 mm
(0.004, 0.008, 0.020 in.)

- When injection timing is retarded, decrease shim thickness. When injection timing is advanced, increase shim thickness.

DISASSEMBLY

Disassemble the parts in the numerical order shown in the figure.

Fig. 6-66

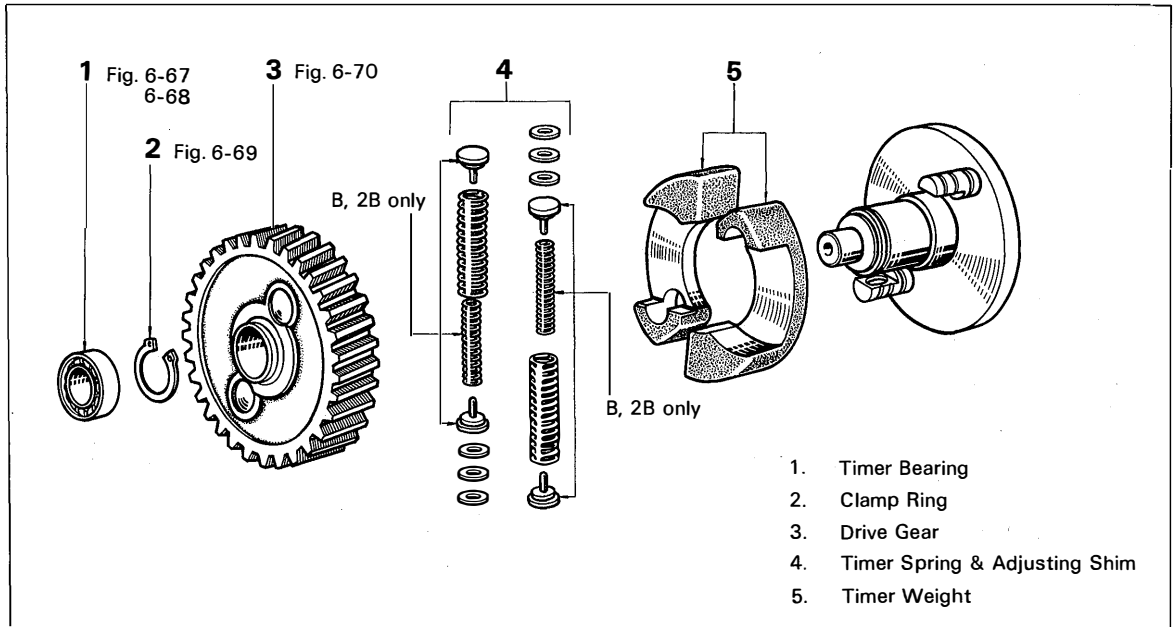
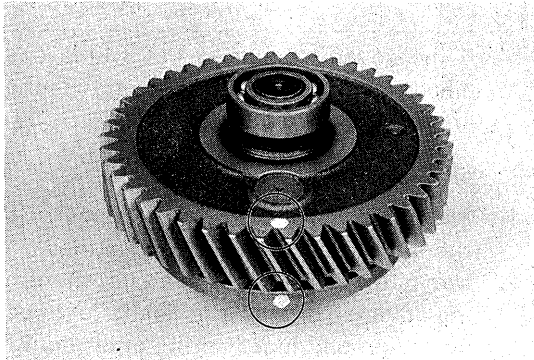
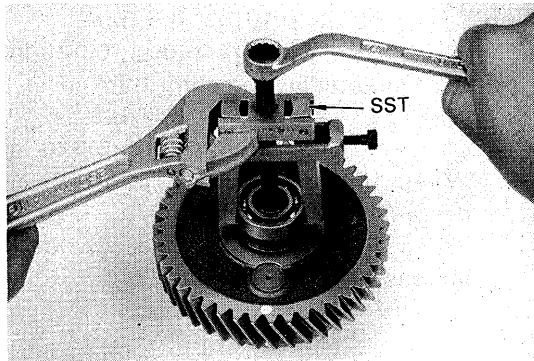

Fig. 6-67



Place matchmarks on the timer hub and drive gear.

Fig. 6-68



Pull out the timer bearing with SST.
SST [09286-46011]

Fig. 6-69

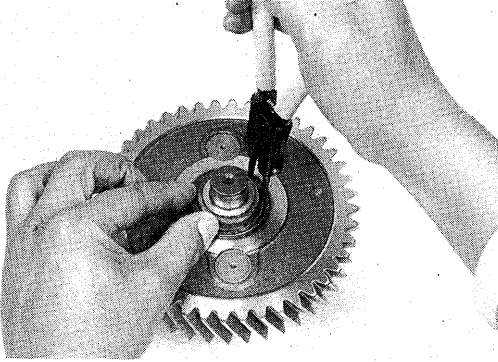

Remove the clamp ring with a snap ring expander.

Fig. 6-70

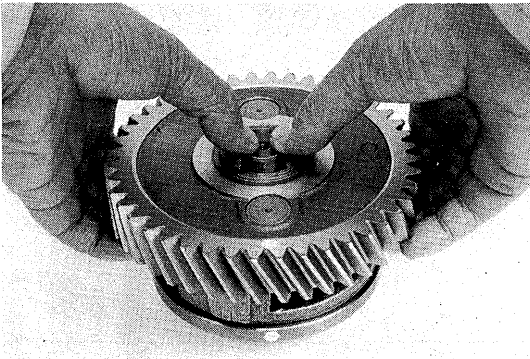

Pull up the drive gear.

—Note—

Be careful that the springs and shims do not fly out.

Fig. 6-71

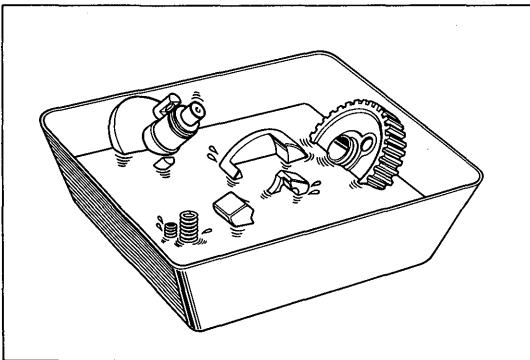

INSPECTION

Clean the parts.

Fig. 6-72

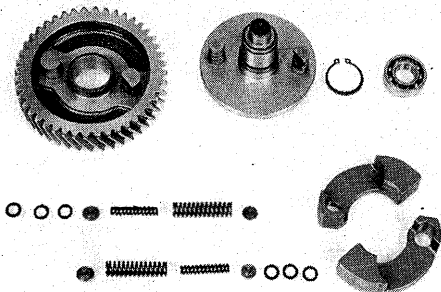

Check all parts for wear or damage.

ASSEMBLY

Assemble the parts in the numerical order shown in the figure.

Fig. 6-73

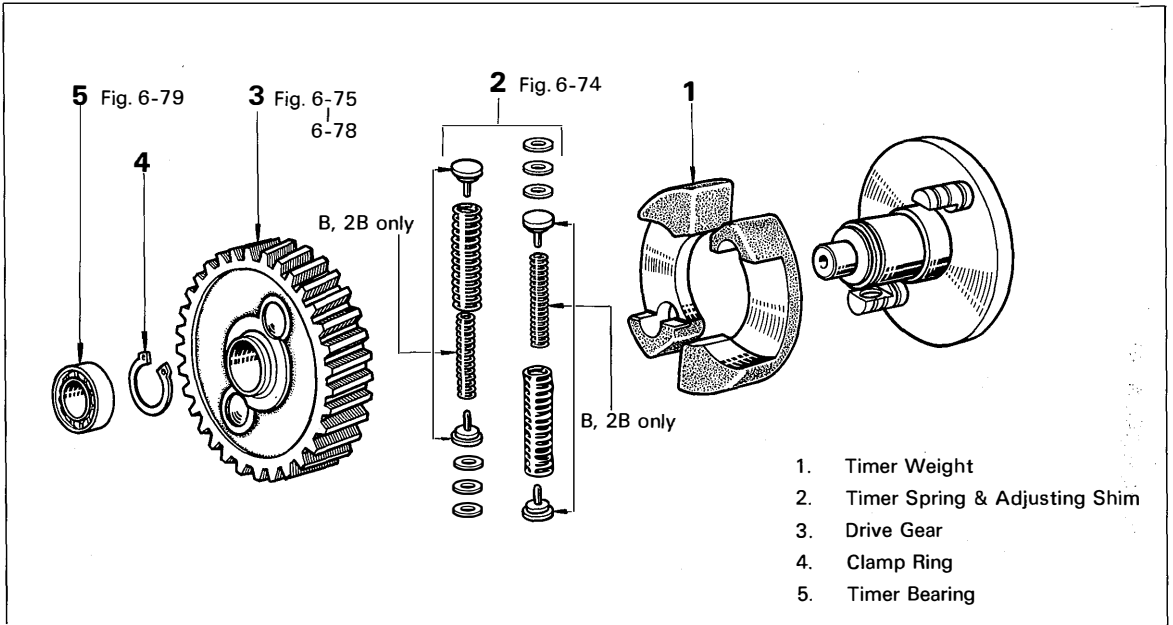
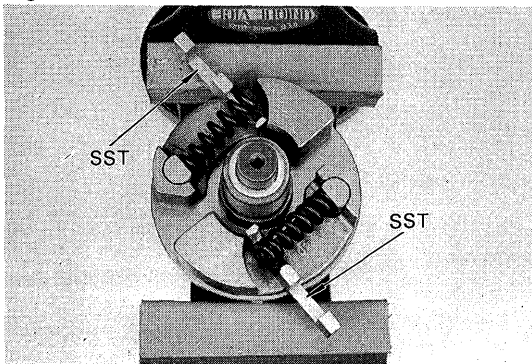
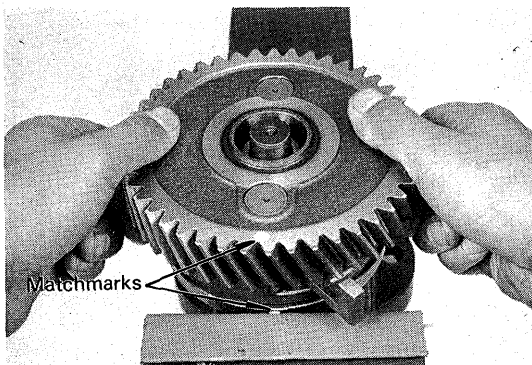

Fig. 6-74



Set the timer springs, adjusting shims and spring seats with SST.
 SST (09280-76010) of set [09260-76016]

Fig. 6-75



Align the matchmarks of the drive gear with that of the timer hub.

Fig. 6-76

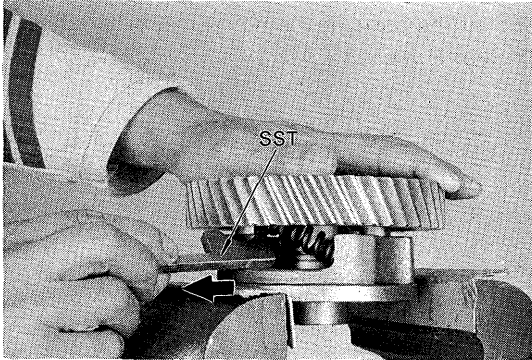

Remove the SST, holding the drive gear so that the springs will not fall out.

Fig. 6-77

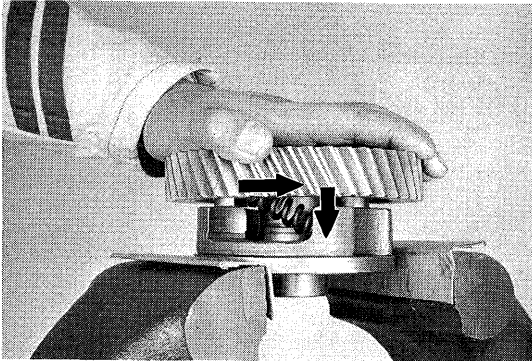

Press down and turn drive gear to install it on the hub.

Fig. 6-78

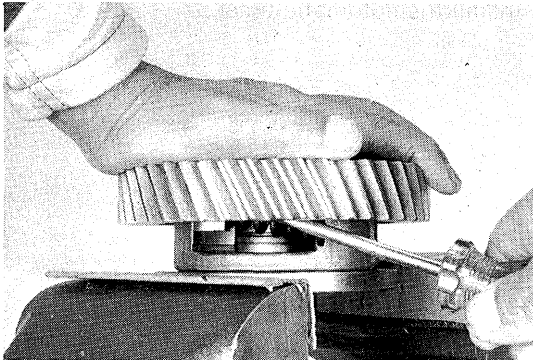

Seat the timer spring snugly with a screw driver.

Fig. 6-79

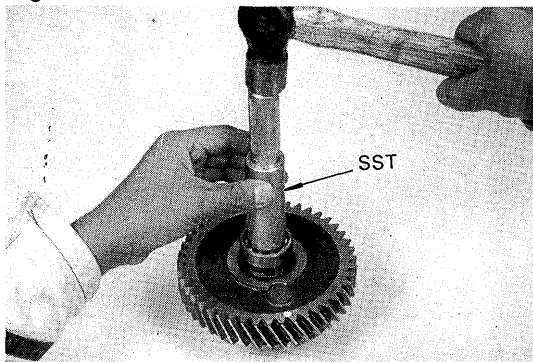

Drive the timer bearing into the timer hub with SST.
SST [09620-30010]

INSTALLATION

Install the parts in the numerical order shown in the figure.

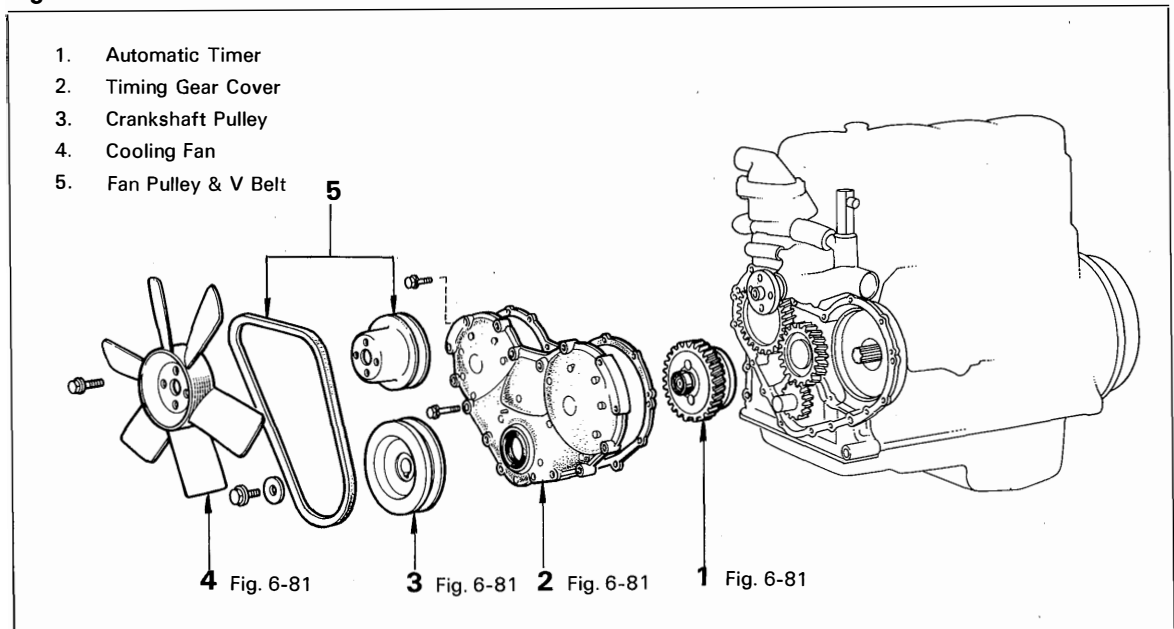
Fig. 6-80**Fig. 6-81**

**SEE
 TIMING GEAR
 INSTALLATION
 SECTION
 Fig. 3-96 to 3-102**

Install the automatic timer.

INJECTION PUMP CUTAWAY VIEW

Fig. 6-82

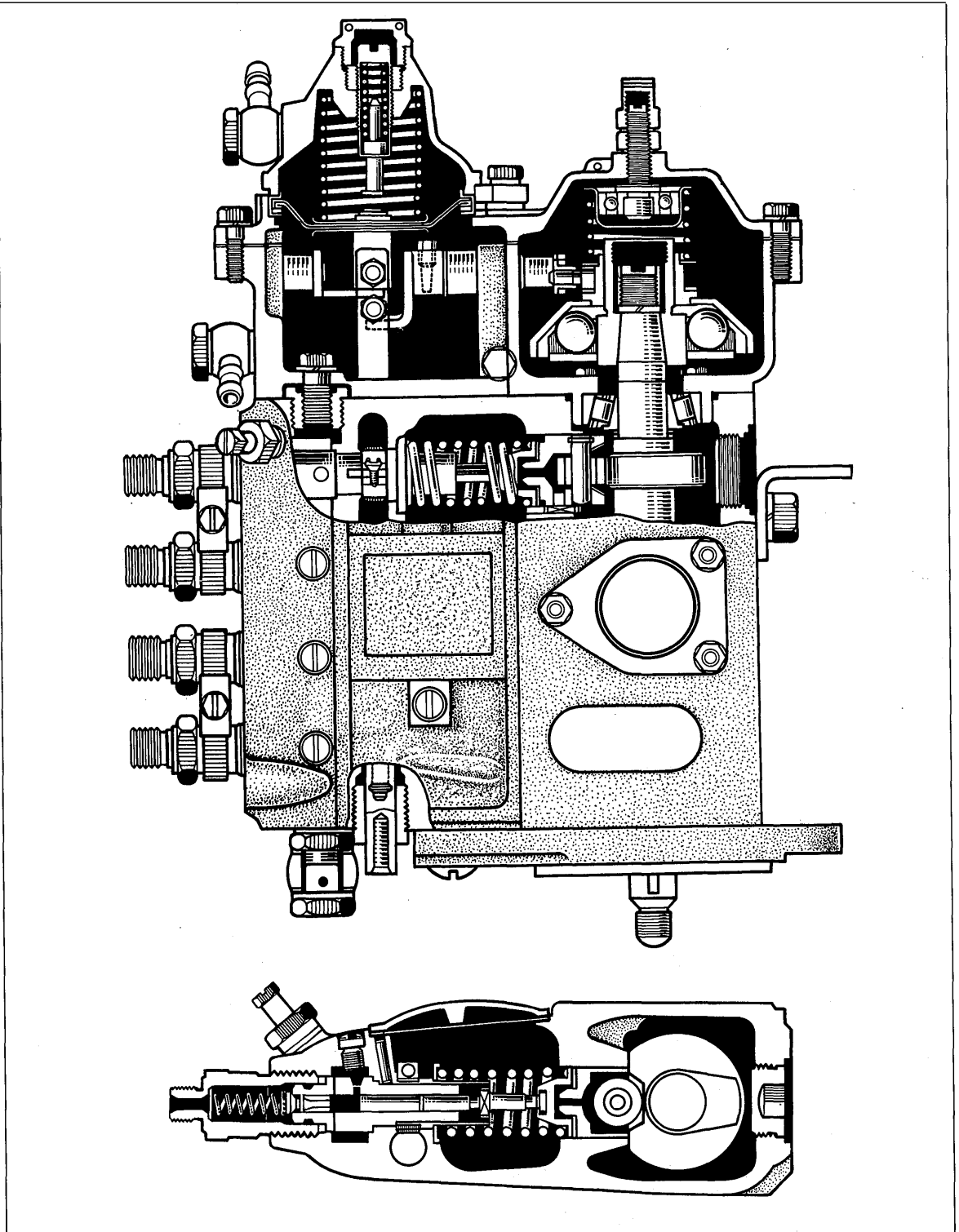

REMOVAL

Remove the parts in the numerical order shown in the figure.

Fig. 6-83

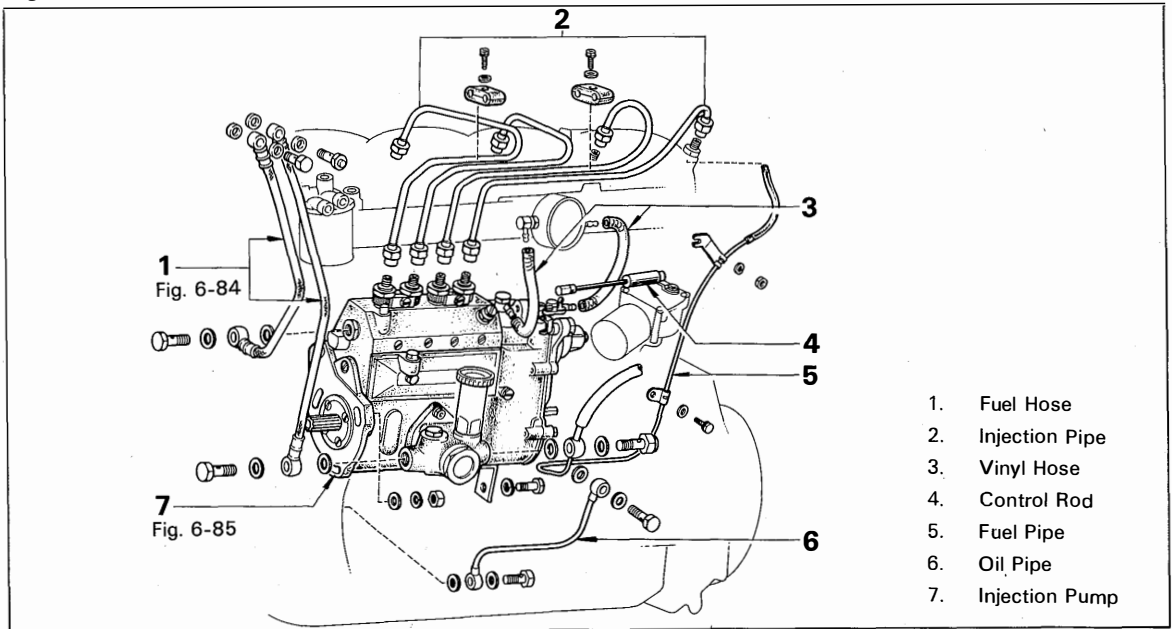
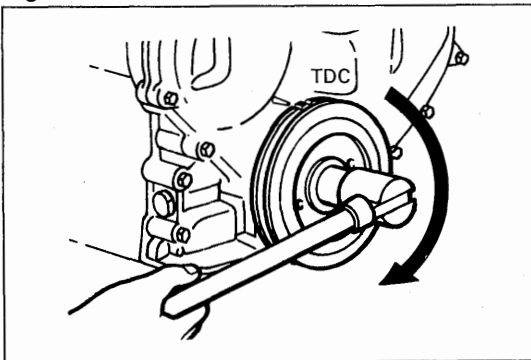
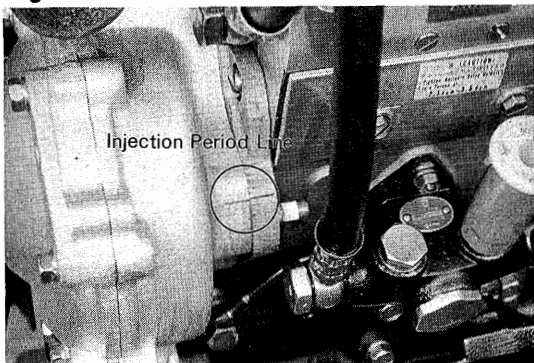

Fig. 6-84



Before starting work, set No.1 cylinder piston at TDC/compression.

Fig. 6-85



Check the position of the injection period line before removing the injection pump.

DISASSEMBLY

Disassemble the parts in the numerical order shown in the figure.

Fig. 6-86

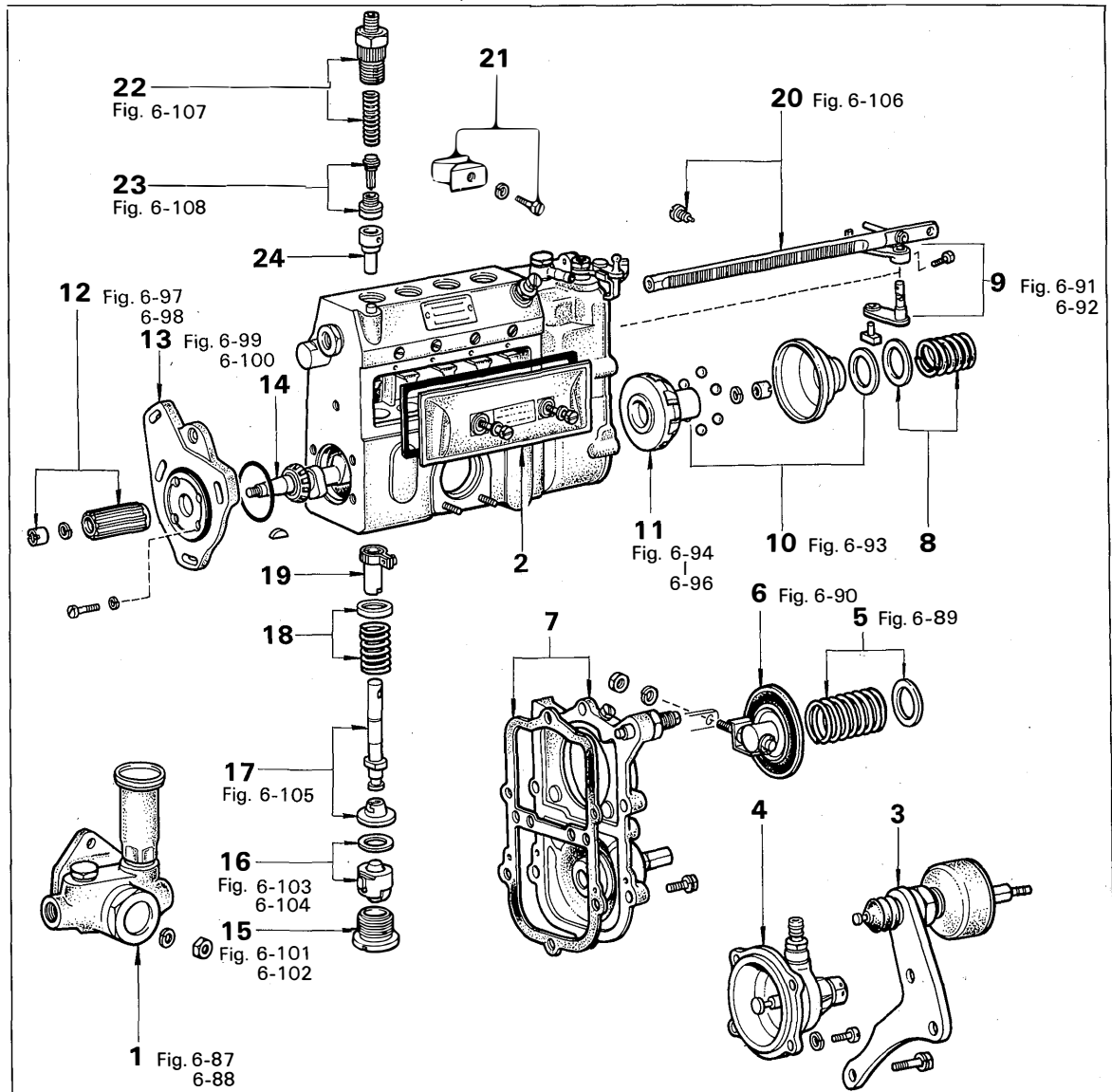

- | | | |
|---------------------------------|---------------------------|------------------------------------|
| 1. Fuel Feed Pump | 9. Control Rack Lever | 17. Plunger & Lower Seat |
| 2. Injection Pump Cover | 10. Slider & Steel Ball | 18. Spring & Upper Seat |
| 3. DHAC & Bracket | 11. Ball Guide | 19. Control Pinion & Sleeve |
| 4. Diaphragm Housing | 12. Spline Shaft | 20. Control Rack |
| 5. Main Spring & Adjusting Shim | 13. Injection Pump Flange | 21. Lock Plate |
| 6. Diaphragm & Connecting Rod | 14. Camshaft | 22. Delivery Valve Holder & Spring |
| 7. Governor Cover | 15. Plug | 23. Delivery Valve & Seat |
| 8. Speed Control Spring | 16. Tappet | 24. Cylinder |

Fig. 6-87

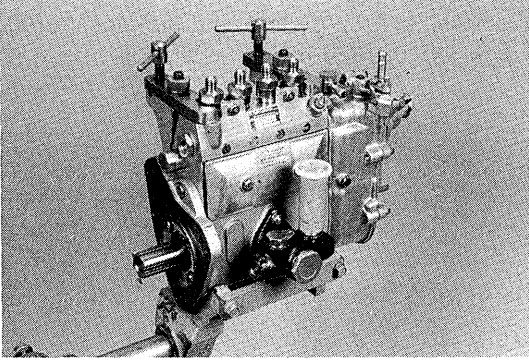

Install the injection pump to the SST.
SST [09241-76021]

Fig. 6-88

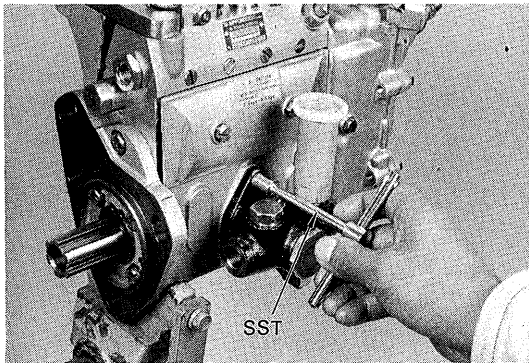

Remove the fuel feed pump with SST.
SST (09276-76010) of set [09260-76016]

Fig. 6-89

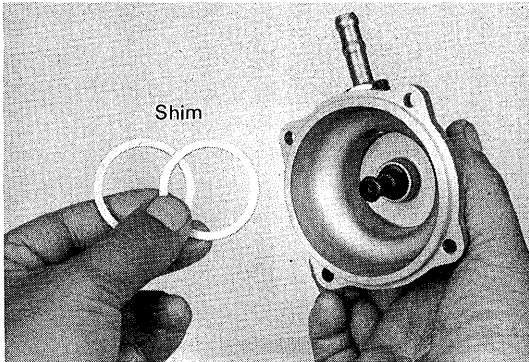

When a number of main spring shims are used, use special care to prevent any from being misplaced or getting mixed up.

Fig. 6-90

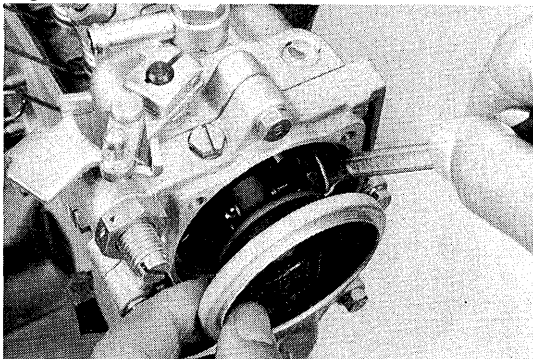

Disconnect the diaphragm from the control rack.

—Note—

Do not allow any engine oil, fuel or grease to get on the diaphragm.

Fig. 6-91

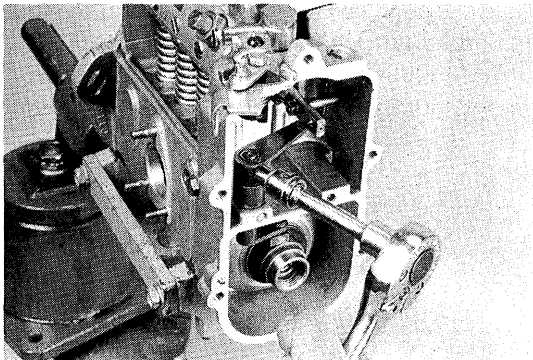

Remove the stop lever bolt with a 6 mm socket wrench.

Fig. 6-92

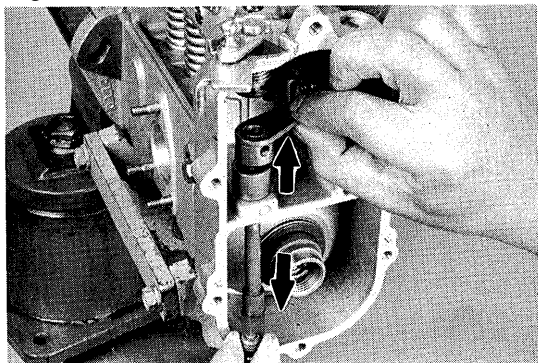

Remove the two control rack levers by pulling upwards and downwards respectively.

Fig. 6-93

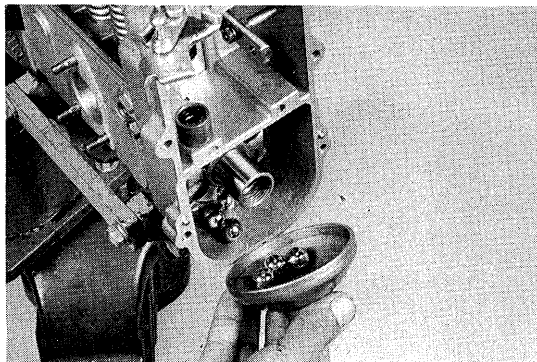

Remove the spring seat and slider, and then take out the six steel balls.

—Note—

Take care not to drop the steel balls.

Fig. 6-94

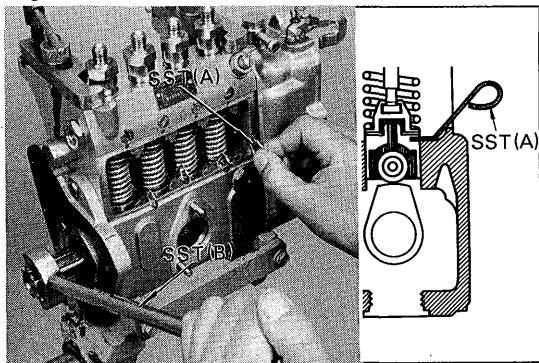

Using SST (B), turn the camshaft and insert SST (A) into the respective tappet service openings when the tappets are at their highest positions.

SST (A) (09274-46010) &

(B) (09278-46010) of set [09260-46011]

Fig. 6-95

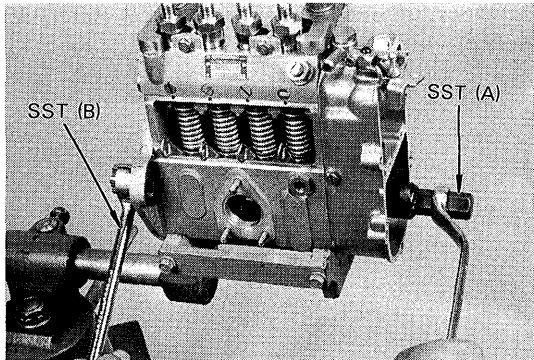

Hold the spline shaft with SST (B) and remove the round nut with SST (A).

SST (A) (09266-67011) of set [09260-76016]
 (B) (09278-46010) of set [09260-46011]

Fig. 6-96

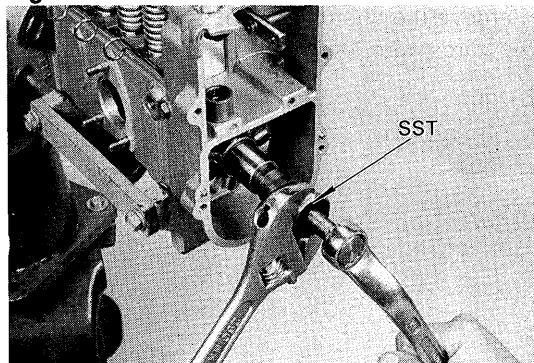

Pull out the ball guide with SST.

SST (09267-76011) of set [09260-76016]

Fig. 6-97

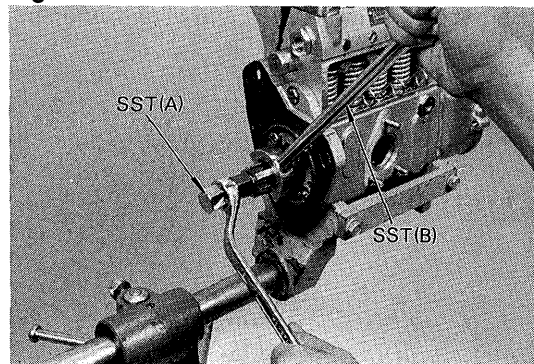

Hold the spline shaft with SST (B) and remove the round nut with SST (A).

SST (A) (09266-46011) &
 (B) (09278-46010) of set [09260-46011]

Fig. 6-98

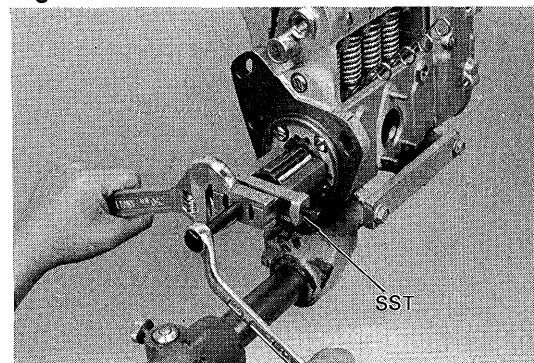

Pull out the spline shaft with SST.
 SST [09286-46011]

Fig. 6-99

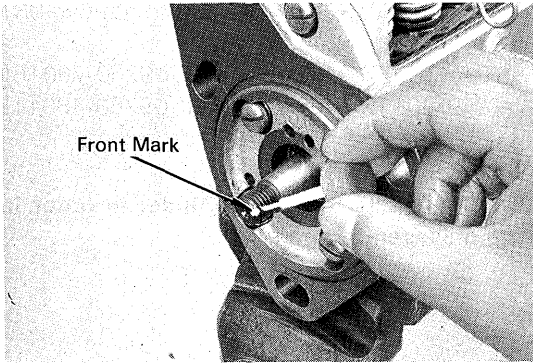

Put a mark on the front side of the camshaft to facilitate work.

Fig. 6-100

**SEE
INJECTION PUMP
ASSEMBLY
SECTION
Fig. 6-149 to 6-153**

Before removing the injection pump flange, measure the thrust clearance and refer to this value when inspecting or reassembling.

Fig. 6-101

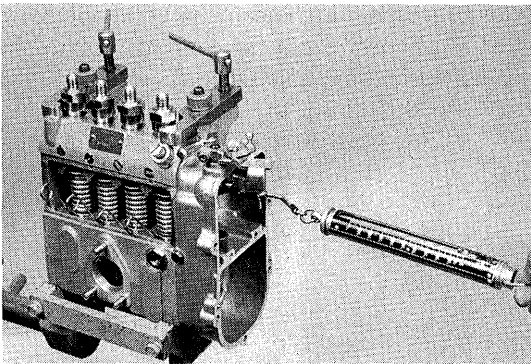

Check the sliding resistance of the control rack.

**Sliding resistance:
Less than 120 g (4.2 oz)**

Fig. 6-102

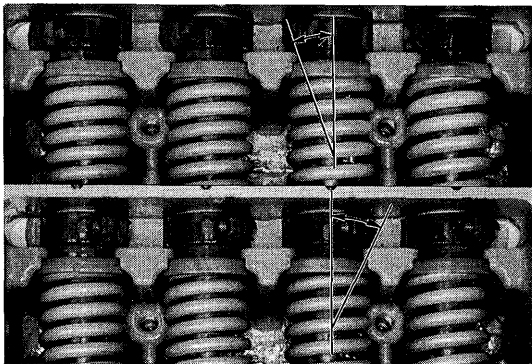

To prevent error when reassembling, confirm the control pinion stop position by moving control rack fully to left and right.

Fig. 6-103

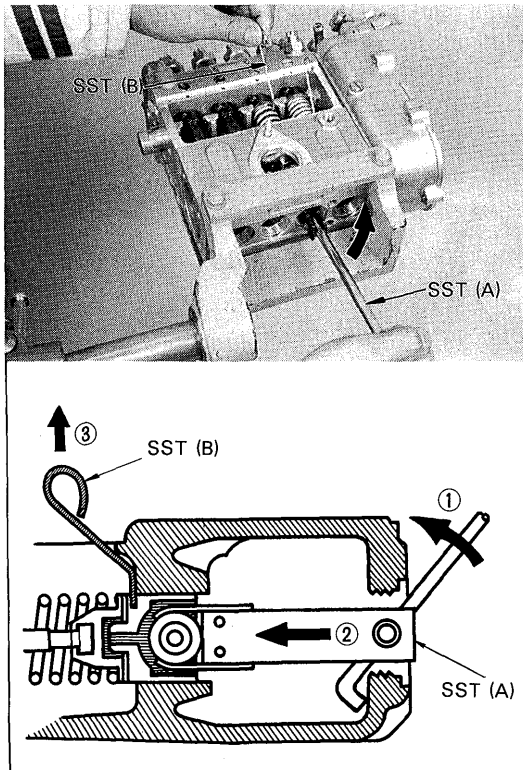

Using SST (A), push the tappet to remove SST (B).

SST (A) (09272-76011) of set [09260-76016]
 (B) (09274-46010) of set [09260-46011]

—Note—

Keep all parts for each cylinder in order in the disassembly pan.

Fig. 6-104

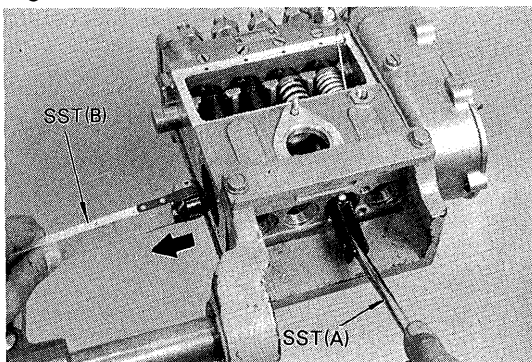

Hold the tappet in the camshaft chamber with SST (A) and take out the tappet through the camshaft bearing hole using SST (B).

SST (A) (09272-76011) &
 (B) (09273-76011) of set [09260-76016]

Fig. 6-105

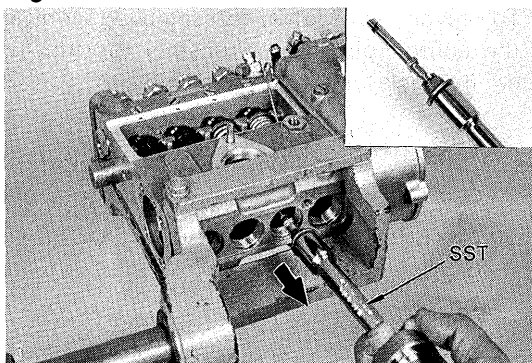

Using SST, hold the spring lower seat and take it out together with the plunger.

SST (09275-46010) of set [09260-46011]

—Note—

Do not touch the sliding surfaces of the delivery valve with your hand.

Fig. 6-106

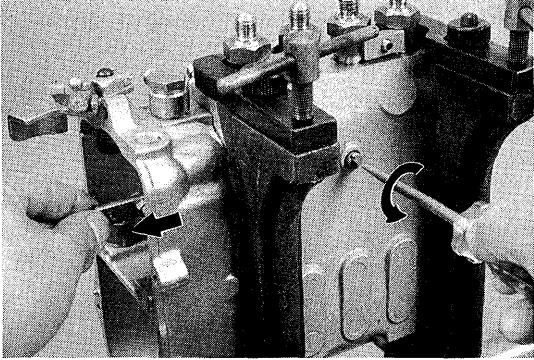

Loosen the rack guide screw and pull out the control rack.

Fig. 6-107

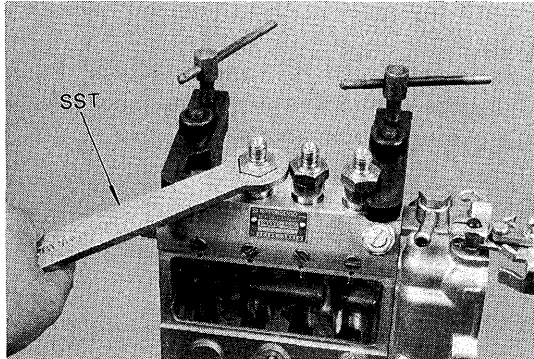

Remove the delivery valve holder with SST. SST (09270-76010) of set [09260-76016]

Fig. 6-108

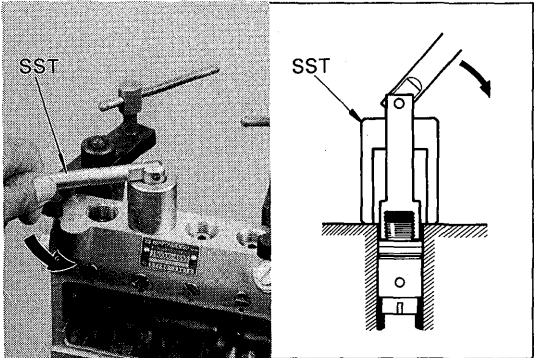

Turn the handle of SST and screw it into the valve seat service thread. Using the handle as lever, pull out the delivery valve seat and gasket together. SST (09271-76011) of set [09260-76016]

—Note—

Do not touch the sliding surfaces of the delivery valve with your hand.

Fig. 6-109

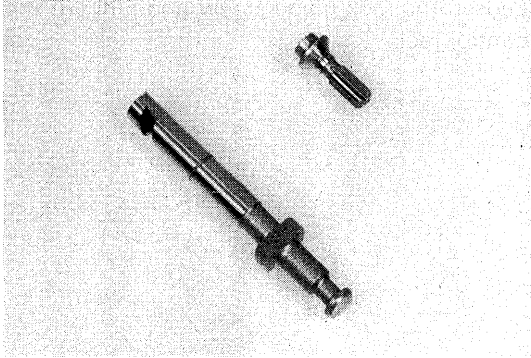
**INSPECTION & REPAIR**

Do not touch the sliding surfaces of the pump plunger and delivery valves.

Fig. 6-110

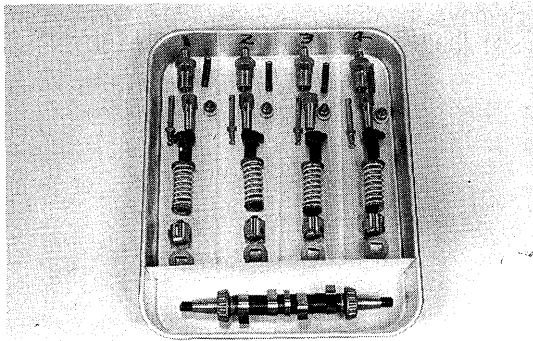

Wash the parts in clean light oil before inspecting.

Wash and clean the outer surfaces of the housings with a soft brush, and blow out the tapped holes with compressed air.

Fig. 6-111

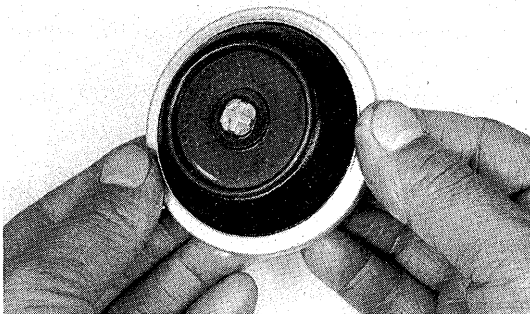
**Diaphragm**

Wipe the diaphragm with cloth. Do not allow gasoline, light oil or other petroleum products to get on the diaphragm.

Fig. 6-112

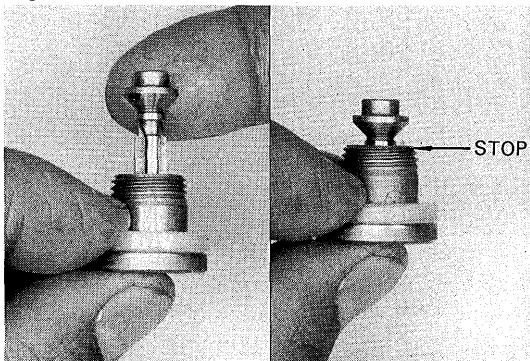
**Delivery Valve**

1. Pull up the valve and close the hole at the valve seat bottom end with your thumb. When the valve is released, it should sink down quickly and stop at the position where the relief ring closes the valve seat hole.

If defective, replace the valve as a set.

Fig. 6-113

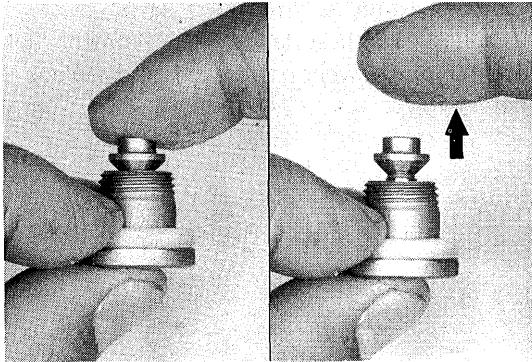

2. Place your thumb over the hole at valve seat bottom end. Insert the valve into the valve seat and press down with your finger. When your finger is released, the valve should rise back to its original position. Replace if defective.

Fig. 6-114

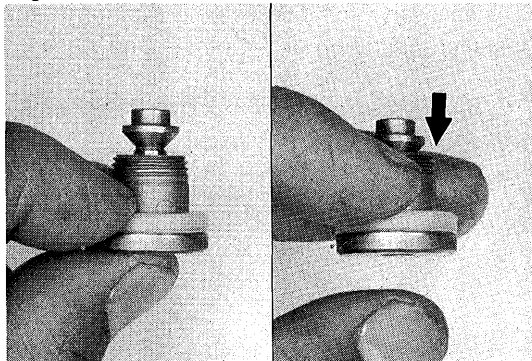

3. Remove your thumb from the valve seat hole. The valve should close completely by its own weight. Replace if defective.

—Note—

Before using a new valve set, wash it with light oil and perform the above tests.

Fig. 6-115

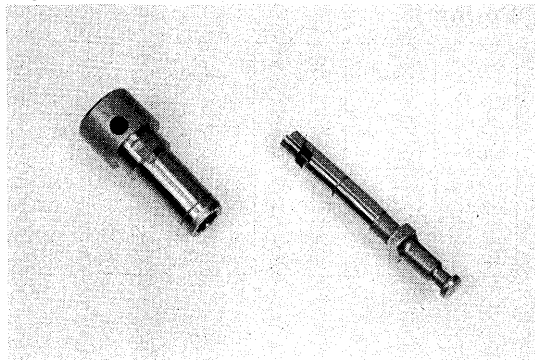

Plunger & Cylinder

Check the sliding parts, and if damaged, replace the element as a set.

Fig. 6-116

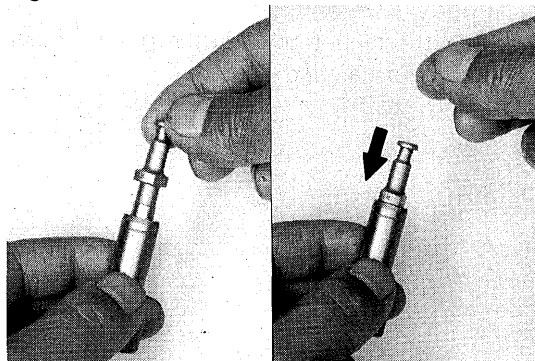

Test for fit. (Sinking test)

1. Tilt the cylinder slightly and pull out the plunger.
2. When released, the plunger should sink down smoothly in the cylinder by its own weight.
3. Rotate the plunger and repeat the test at various positions. If the plunger sticks at any position, replace the element as a set.

Fig. 6-117

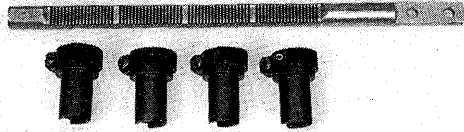

Control Rack & Pinion

Check the tooth surfaces of the control rack and pinion for wear or damage, and replace if defective.

Fig. 6-118

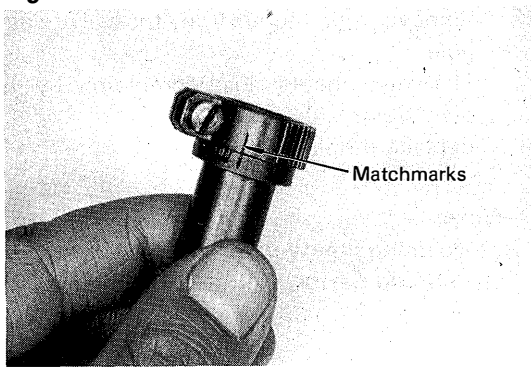

If necessary to disassemble, confirm the installed condition of the pinion and sleeve.

Fig. 6-119

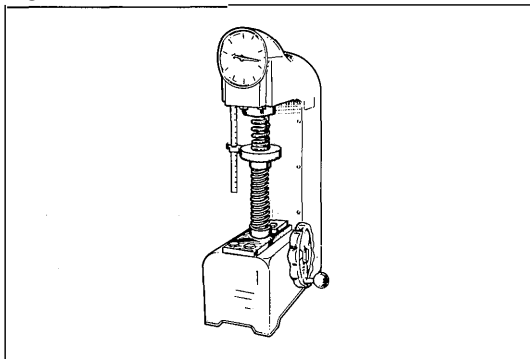

Spring

Spring Items	Plunger spring	Delivery valve spring	Governor main spring		Speed control spring
			B & 2B	3B	
Free length	49.4 mm (1.945 in.)	37.0 mm (1.457 in.)	45.6 mm (1.795 in.)	51.6 mm (2.031 in.)	38.0 mm (1.496 in.)
Installed length	44.0 mm (1.732 in.)	25.9 mm (1.020 in.)	35.0 mm (1.378 in.)	36.5 mm (1.437 in.)	27.0 mm (1.063 in.)
Installed load	15.1 kg (33 lb)	4.42 kg (10 lb)	0.954 kg (2.1 lb)	1.057 kg (2.3 lb)	3.30 kg (7 lb)

Fig. 6-120

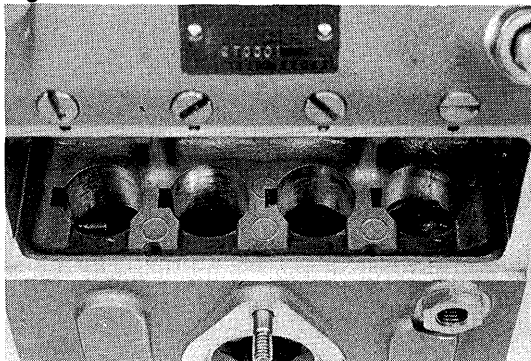

Tappet

Check the tappet holes of the pump housing for wear or damage.

Fig. 6-121

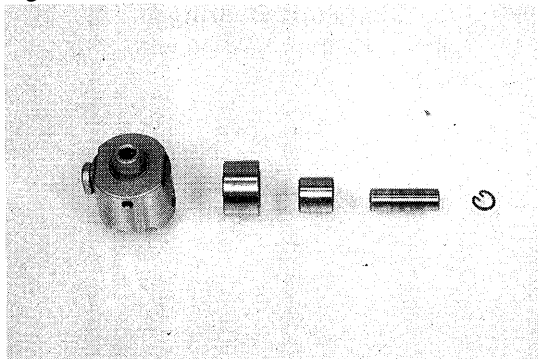

Check the tappet, roller bushing and pin for wear or damage.

Fig. 6-122

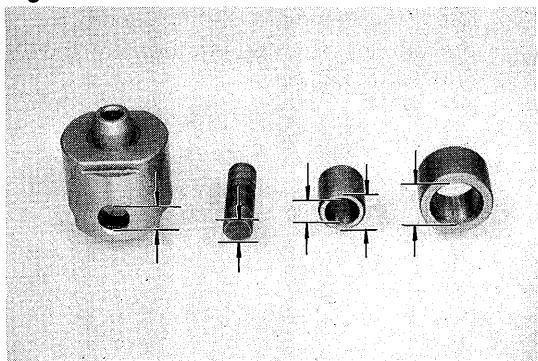

Measure the overall looseness with the tappet roller in the assembled state, and replace if it exceeds the specified limit.

Overall looseness:

**Limit 0.3 mm
(0.012 in.)**

Fig. 6-123

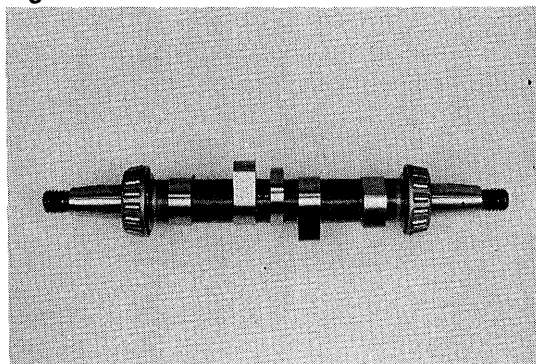

Camshaft

Check the cam surfaces for wear or damage.

Fig. 6-124

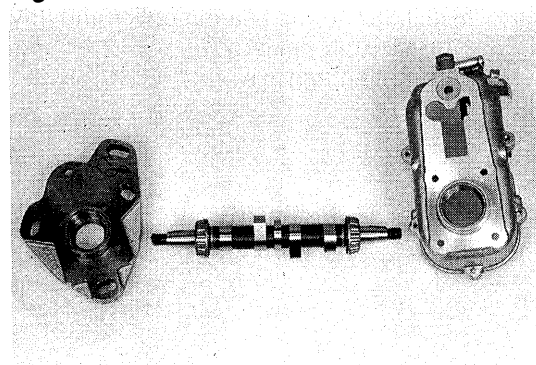

Camshaft Bearing

Check the roller and race for wear or damage.

Fig. 6-125

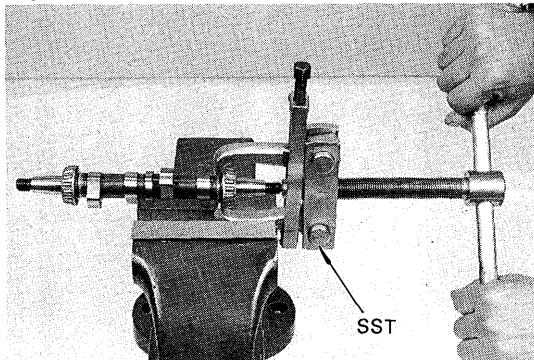
**Replace Camshaft Bearing**

1. Pull out the front bearing with SST.
SST [09950-20014]

Fig. 6-126

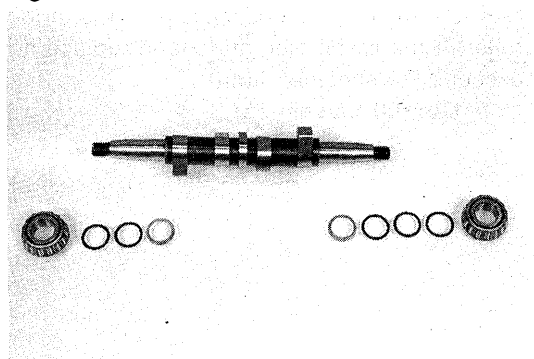

2. Keep the removed shims separately to prevent loss or getting them mixed up with other shims.

Fig. 6-127

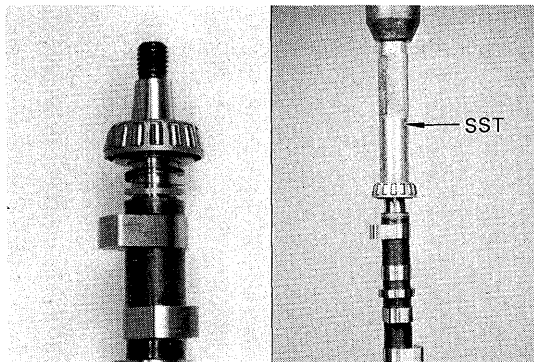

3. Using a press and SST, press in the camshaft adjusting ring, shims and bearing onto the camshaft.
SST [09285-76010]

Fig. 6-128

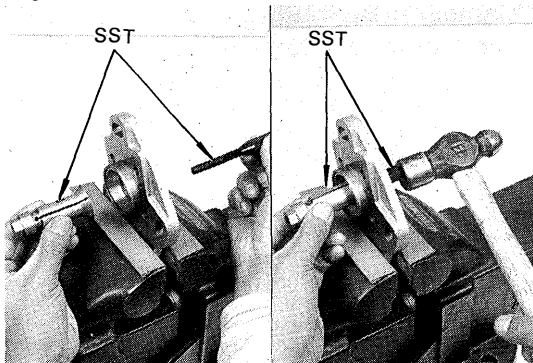

4. Install SST to the bearing cover and drive out the outer race.
SST [09286-76011]

Fig. 6-129

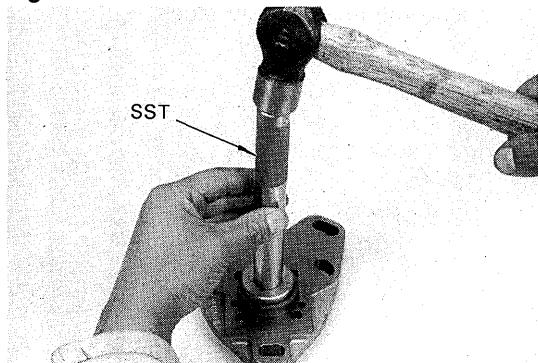

5. Drive a new bearing outer race into the cover with SST.
SST [09608-12010]

Fig. 6-130

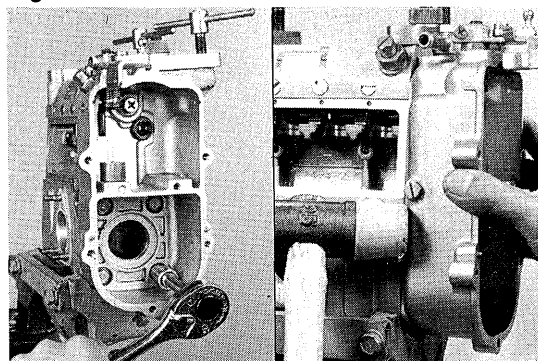

6. Remove the governor housing from the pump body.

Fig. 6-131

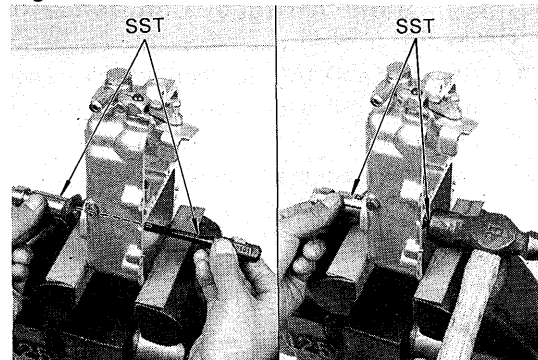

7. Install SST to the governor housing and drive out the outer race.
SST [09286-76011]

Fig. 6-132

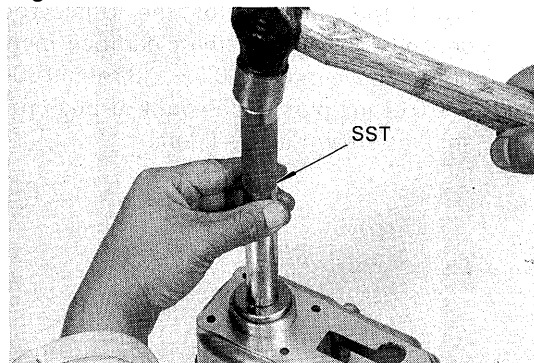

8. Drive a new bearing outer race into the governor housing with SST.
SST [09608-12010]

Fig. 6-133

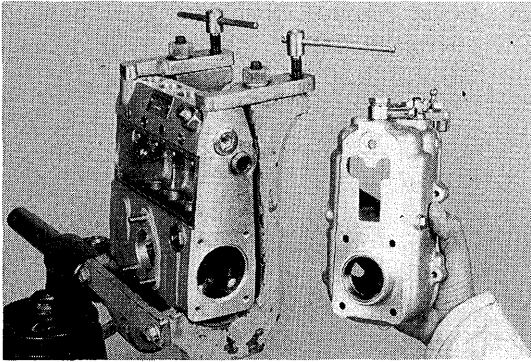

- Clean the installing surfaces.

Fig. 6-134

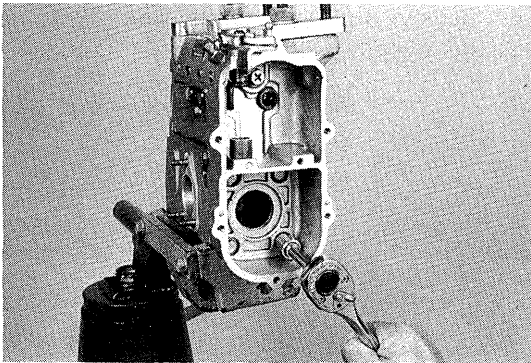

- Install a new gasket and the governor housing.

Fig. 6-135

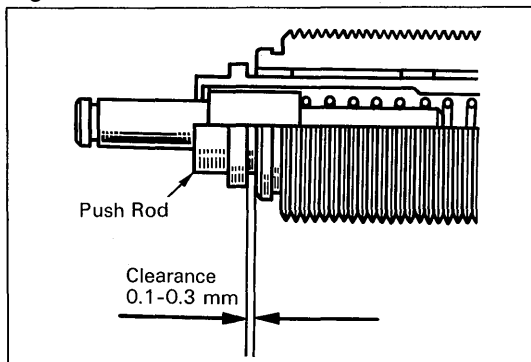

Diesel High Altitude Compensator (DHAC)

- Check the DHAC for correct clearance between full stop capsule flange and DHAC body.

Clearance at sea level:

0.1 – 0.3 mm

(0.004 – 0.012 in.)

Fig. 6-136

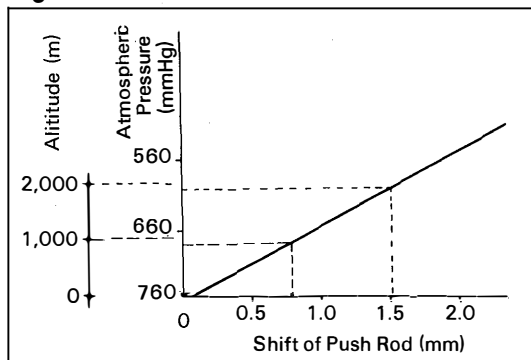

- Since the position of the push rod depends on altitude, the clearance mentioned above must be 0.1 – 0.3 mm (0.004 – 0.012 in.) plus the amount of push rod shift, as shown in the figure.

ASSEMBLY (PUMP BODY)

Assemble the parts in the numerical order shown in the figure.

Fig. 6-137

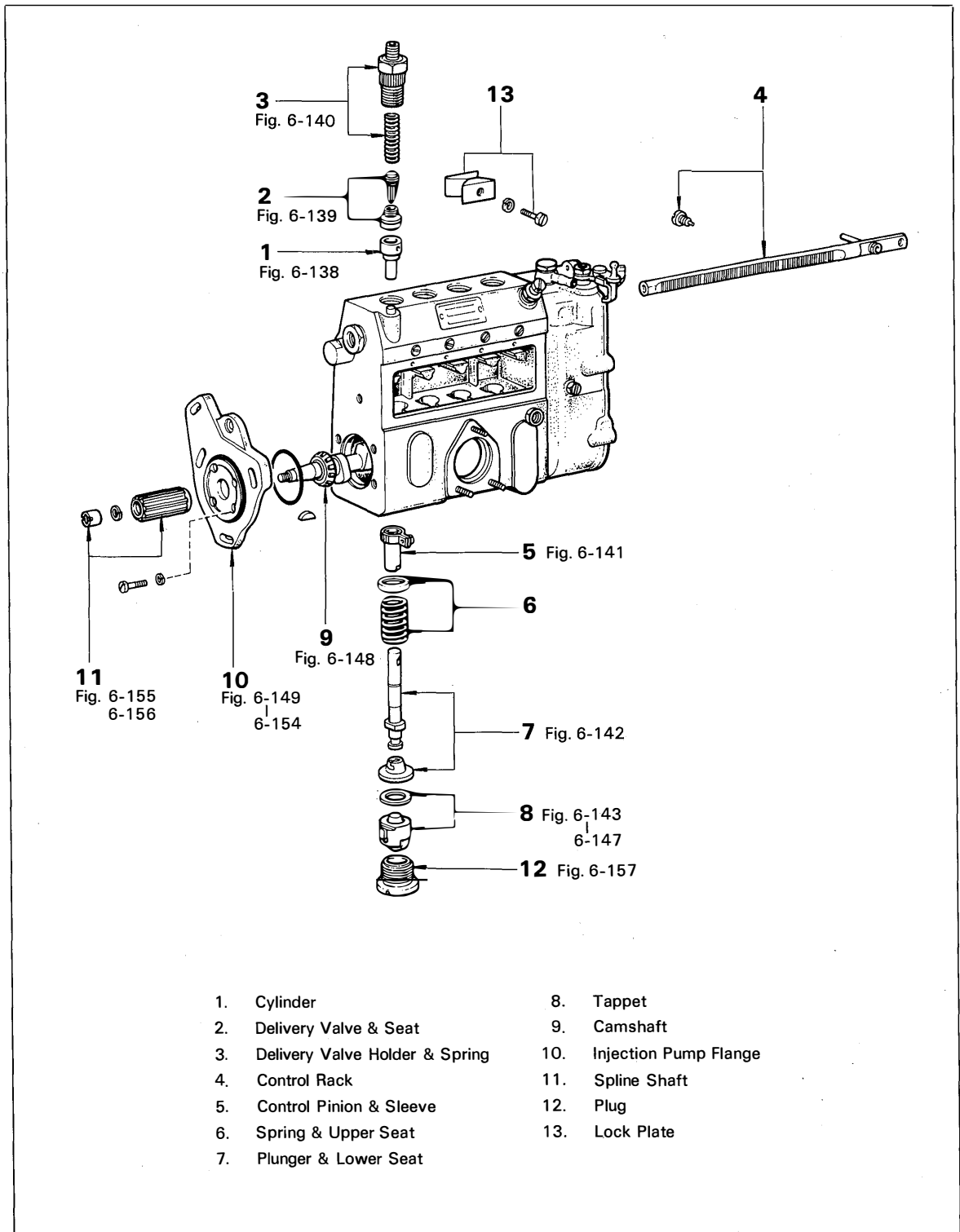

- | | |
|-----------------------------------|---------------------------|
| 1. Cylinder | 8. Tappet |
| 2. Delivery Valve & Seat | 9. Camshaft |
| 3. Delivery Valve Holder & Spring | 10. Injection Pump Flange |
| 4. Control Rack | 11. Spline Shaft |
| 5. Control Pinion & Sleeve | 12. Plug |
| 6. Spring & Upper Seat | 13. Lock Plate |
| 7. Plunger & Lower Seat | |

Fig. 6-138

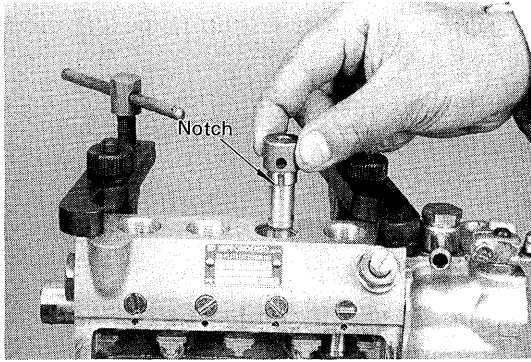

To assemble the cylinder, match the pump cylinder notch with the pump housing knock pin.

Fig. 6-139

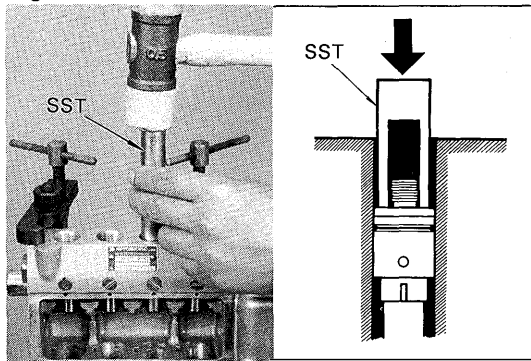

Drive in the pump cylinder lightly with SST. SST (09262-76010) of set [09260-76016]

Fig. 6-140

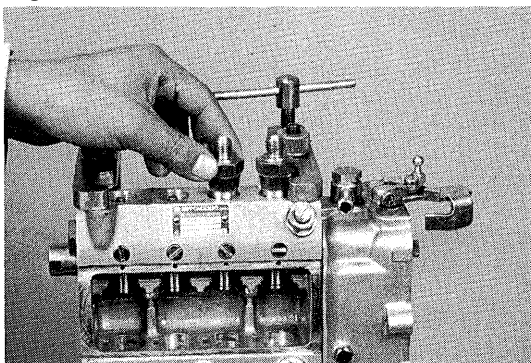

Lightly tighten the delivery valve holder by hand.

Fig. 6-141

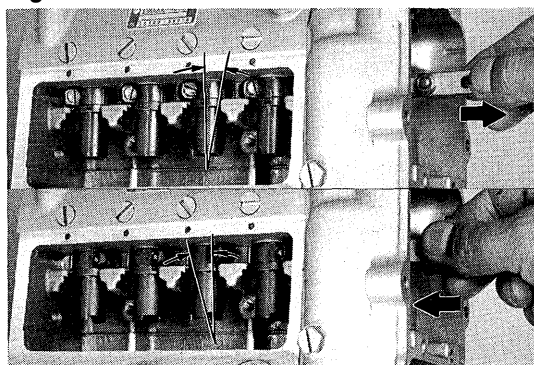

Assemble so that the pinion swings evenly left and right when rack is moved to the right and left.

When assembling the sleeves, inspect the fitting condition by moving the rack.

Fig. 6-142

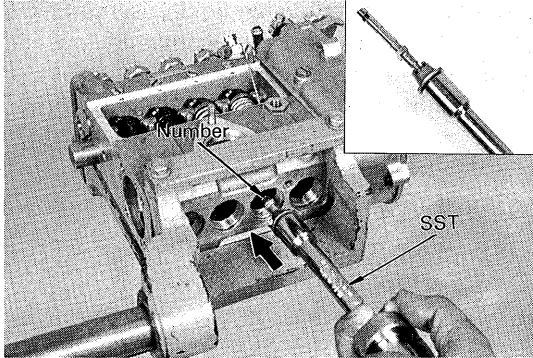

Using SST, assemble the plunger and spring lower seat, inserting the driving face marked with a number and lower seat notch part upward (cover plate side).
SST (09275-46010) of set [09260-46011]

Fig. 6-143

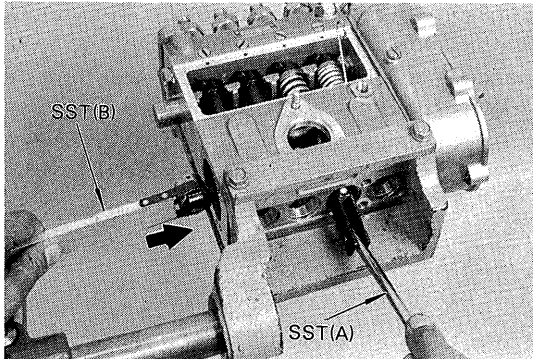

Insert the tappet into housing with SST (A) and (B).
SST (A) (09272-76011) &
(B) (09273-76011) of set [09260-76016]

Fig. 6-144

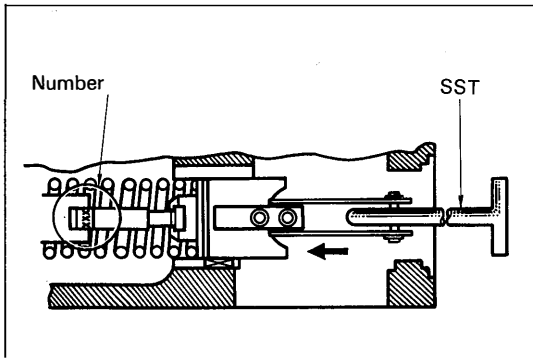

Fit the driving face into the cylinder groove, facing its number toward pump cover side.

Fig. 6-145

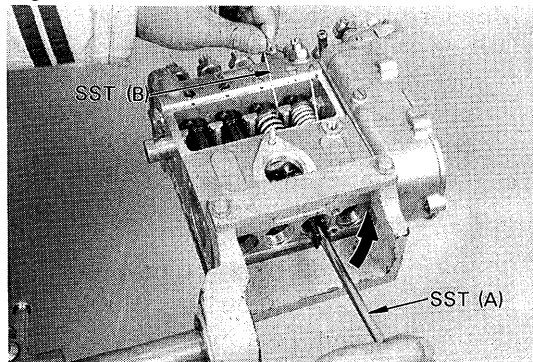

Press in the tappet with SST (A) and hold it with SST (B).
SST (A) (09272-76011) of set [09260-76016]
(B) (09274-46010) of set [09260-46011]

Fig. 6-146

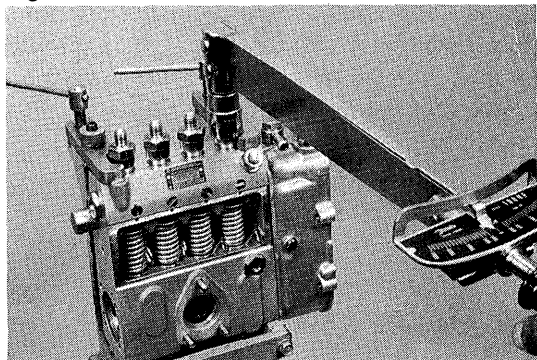

When one delivery valve holder is tightened, move the control rack to right and left and inspect the tightness of the rack.

Tightening torque: 2.5 – 3.5 kg-m
(19 – 25 ft-lb)

Fig. 6-147

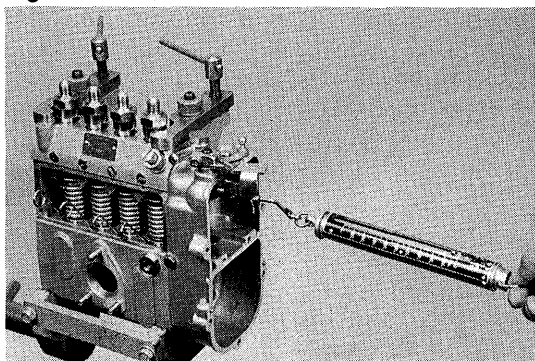

Measure the control rack sliding resistance with a spring scale, and confirm that the resistance is less than 120 g (4.2 oz) and the rack moves smoothly.

Sliding resistance:
Less than 120 g (4.2 oz)

Fig. 6-148

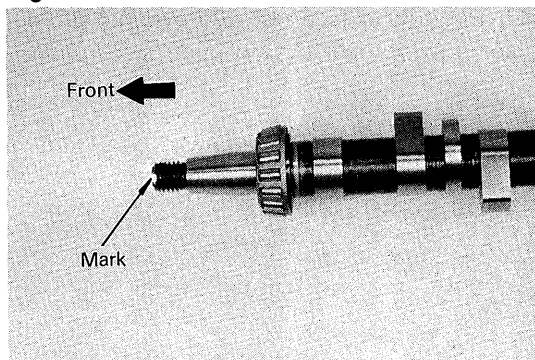

Assemble the camshaft, facing the mark put on during removal toward front.

Fig. 6-149

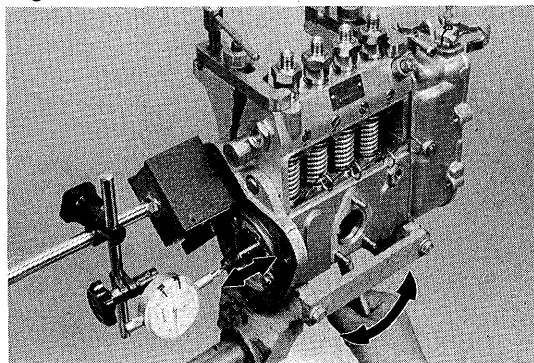

Measure Camshaft Thrust Clearance [When Dial Gauge is used]

1. Set the magnetic base on the injection pump flange and contact the dial gauge with the end of camshaft.
2. Pry the camshaft with a wooden stick and check the thrust clearance.

Thrust clearance:

STD 0.03 – 0.05 mm
(0.0012 – 0.0020 in.)

Limit 0.1 mm
(0.004 in.)

Fig. 6-150

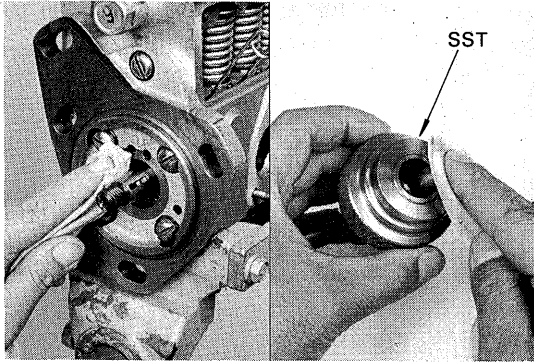

Measure Camshaft Thrust Clearance
[When SST [09287-76010] is used]

1. Clean the injection pump flange and SST.

Fig. 6-151

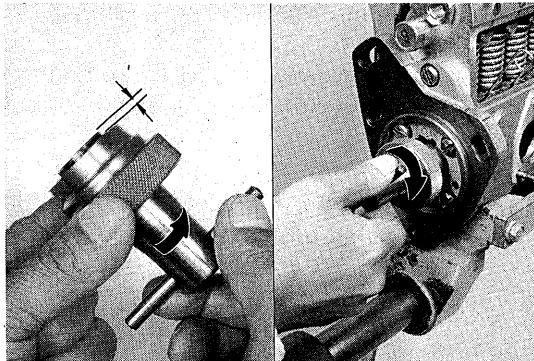

2. Firmly install SST to the camshaft.

Fig. 6-152

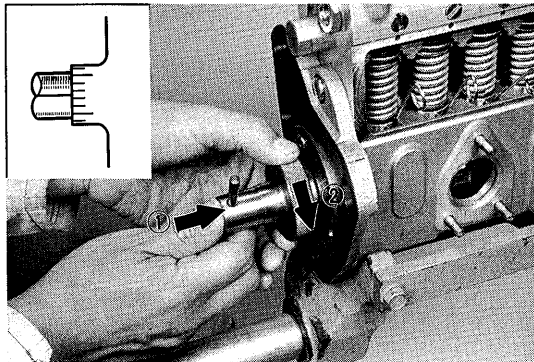

3. Push SST toward the pump side, and contact the outer dial with the pump flange by screwing in the outer dial.
4. Read the scale on outer dial.

—Note—

A unit on the outer dial scale is equivalent to 0.01 mm (0.0004 in.).

Fig. 6-153

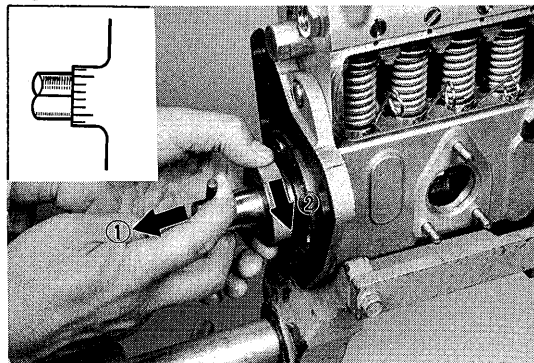

5. Pull SST toward the front side, and contact the outer dial with the pump flange by screwing in the outer dial.
6. The screwing distance is the camshaft thrust clearance.

Thrust clearance:

STD 0.03 – 0.05 mm
(0.0012 – 0.0020 in.)

Limit 0.1 mm
(0.004 in.)

Fig. 6-154

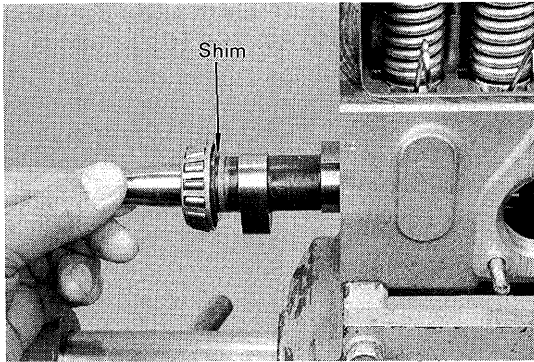

To adjust the thrust clearance, increase or decrease the number of camshaft adjusting shims.

Shim thickness mm (in.)	
0.10 (0.0039)	0.16 (0.0063)
0.12 (0.0047)	0.18 (0.0071)
0.14 (0.0055)	0.50 (0.0197)

Fig. 6-155

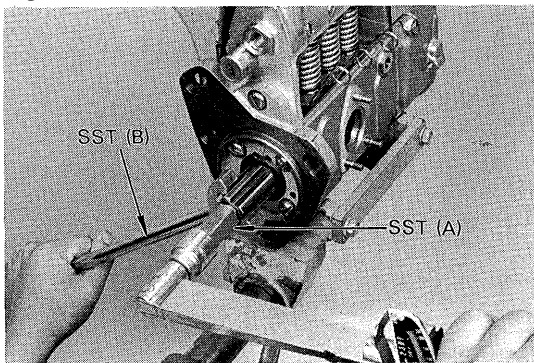

—Note—

Refer to "Replace Camshaft Bearing" on Fig. 6-125 to 6-127 for replacement of adjusting shim.

Hold the spline shaft with SST (B) and tighten the round nut with SST (A) and a torque wrench.

SST (A) (09266-46011) &
(B) (09278-46010) of set [09260-46011]

**Tightening torque: 6.0 – 7.0 kg-m
(44 – 50 ft-lb)**

Fig. 6-156

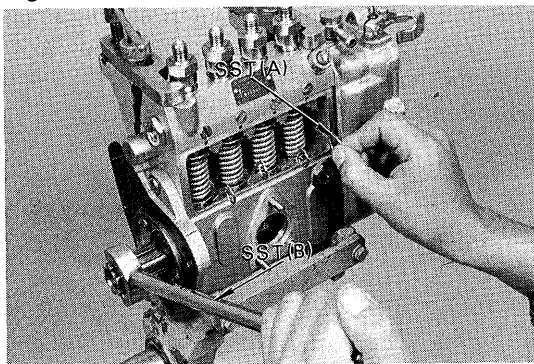

Using SST (B), rotate the camshaft and remove SST (A).

SST (A) (09274-46010) &
(B) (09278-46010) of set [09260-46011]

Fig. 6-157

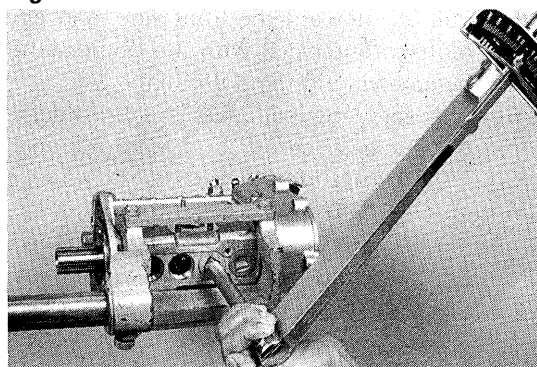

Install the felt plate plugs.

**Tightening torque: 5.5 – 7.5 kg-m
(40 – 54 ft-lb)**

ADJUSTMENT (PUMP BODY)

Pump Body Adjustment Items

Preparations of Pump Tester

Nozzle type		ND-DN 4 SD-24A	
Nozzle	Opening pressure	115 – 125 kg/cm ²	1,636 – 1,778 psi
Injection pipe	Outer diameter	6.0 mm	0.236 in.
	Inner diameter	2.0 mm	0.079 in.
	Length	600 mm	23.62 in.
	Minimum bending radius	More than 25 mm	0.98 in.
Fuel temperature		40 – 45°C	104 – 113°F
Fuel feeding pressure		0.5 kg/cm ²	7 psi

Control Rack Sliding Resistance

Pump rpm	Sliding resistance
0	Less than 120 g (4.2 oz)
1,000	Less than 50 g (1.8 oz)

Injection Timing

Pre-stroke	1.9 – 2.0 mm 0.075 – 0.079 in. [Control rack position at 8.0 mm (0.315 in.)]
Injection interval	90° ± 30'
Tappet clearance	More than 0.2 mm (0.008 in.)

Injection Volume Adjustment

[For B Engine]

Rack position mm (in.)	Pump revolution (rpm)	Measuring strokes	Injection volume cc (cu in.)	Variation limit cc (cu in.)
16.0 (0.630)	100	200	14.0 – 16.0 (0.85 – 0.98)	1.2 (0.07)
11.7 (0.461)	1,100	200	10.0 – 10.6 (0.61 – 0.65)	0.4 (0.02)
8.6 (0.339)	1,000	200	4.6 – 5.6 (0.28 – 0.34)	0.4 (0.02)
6.5 (0.256)	325	500	2.5 – 4.5 (0.15 – 0.27)	1.0 (0.06)

[For 2B Engine]

Rack position mm (in.)	Pump revolution (rpm)	Measuring strokes	Injection volume cc (cu in.)	Variation limit cc (cu in.)
16.0 (0.630)	100	200	14.0 – 16.0 (0.85 – 0.98)	1.2 (0.07)
11.9 (0.469)	1,100	200	11.0 – 11.6 (0.67 – 0.71)	0.4 (0.02)
8.0 (0.315)	1,000	200	4.3 – 5.1 (0.26 – 0.31)	0.4 (0.02)
6.5 (0.256)	325	500	2.5 – 4.5 (0.15 – 0.27)	1.0 (0.06)

[For 3B Engine]

Rack position mm (in.)	Pump revolution (rpm)	Measuring strokes	Injection volume cc (cu in.)	Variation limit cc (cu in.)
17.5 (0.689)	100	200	14.0 – 16.0 (0.85 – 0.98)	1.2 (0.07)
13.0 (0.512)	1,100	200	11.3 – 11.9 (0.69 – 0.73)	0.4 (0.02)
13.0 (0.512)	1,700	200	11.5 – 12.5 (0.70 – 0.76)	0.6 (0.04)
8.0 (0.315)	1,000	200	4.3 – 5.1 (0.26 – 0.31)	0.4 (0.02)
6.5 (0.256)	325	500	2.5 – 4.5 (0.15 – 0.27)	1.0 (0.06)

Fig. 6-158

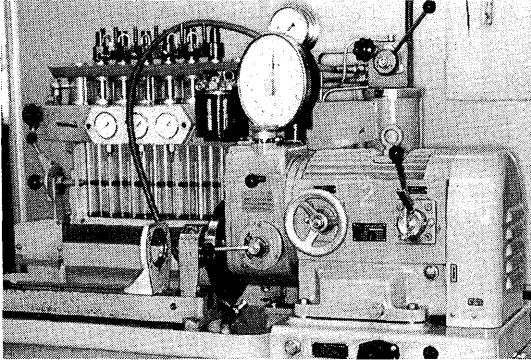

Fig. 6-159

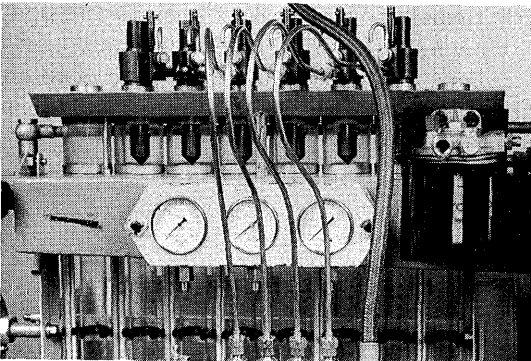

Fig. 6-160

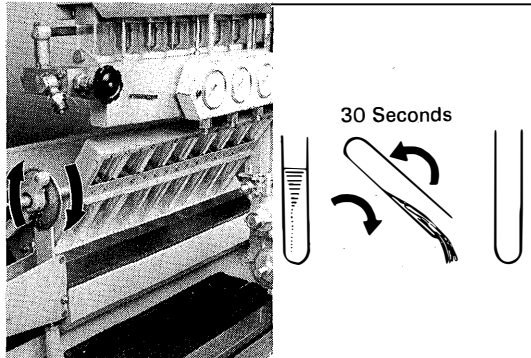
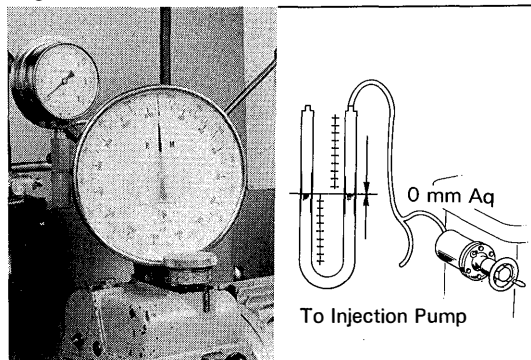

Fig. 6-161



Pre-test Check & Preparations

1. Specifications for test nozzle and nozzle holder are as follows:

Nozzle ND-DN4 SD-24A

Nozzle holder valve

opening pressure:

**115 – 125 kg/cm²
(1,636 – 1,778 psi)**

2. Use injection pipes with the following specifications.

**Outer diameter: 6.0 mm
(0.236 in.)**

**Inner diameter: 2.0 mm
(0.079 in.)**

**Length: 600 mm
(23.62 in.)**

**Minimum bending radius:
More than 25 mm (0.98 in.)**

3. Measure injection of each cylinder with specified measuring cylinder.
4. Tilt the measuring cylinders for 30 seconds to remove the diesel fuel, and then, raise the cylinders upright and measure.

5. Check tachometer accuracy.

Allowable error: ±40 rpm

6. Confirm that both water columns of U-tube are of the same height, and align the zero point on the scale at that height.

Fig. 6-162

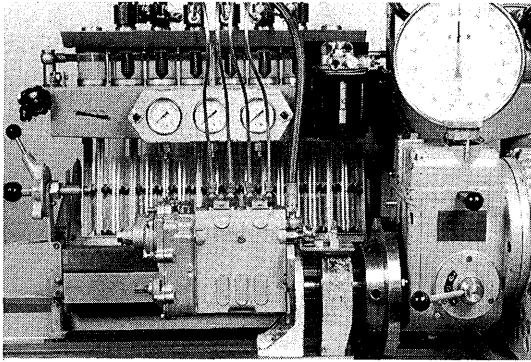

7. Mount the injection pump body on the pump tester.

Fig. 6-163

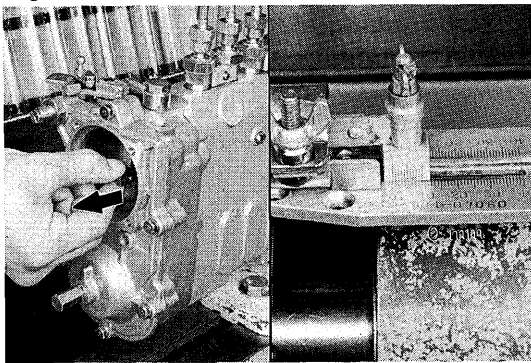

8. Install the rack scale so that its zero point will be at the position where the control rack is pushed fully toward the governor side, and set to allow easy reading of scale graduations.

Fig. 6-164

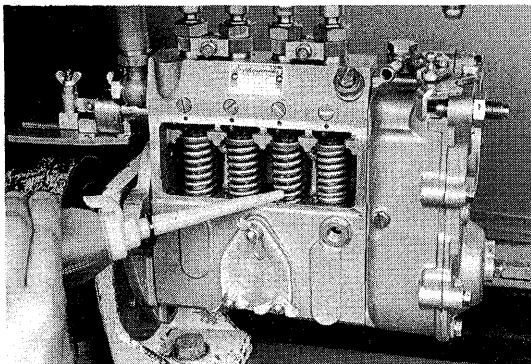

9. Install cover to the feed pump mounting surface, and fill the pump camshaft chamber with engine oil.

Fig. 6-165

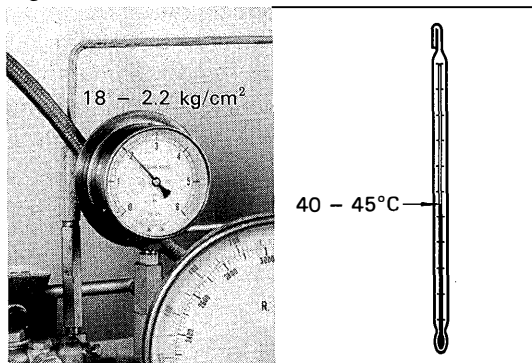

10. Fuel feeding pressure to injection pump should be 1.8 – 2.2 kg/cm² (26 – 31 psi).
11. Fuel temperature for pump testing should be 40 – 45°C (104 – 113°F).

Fig. 6-166

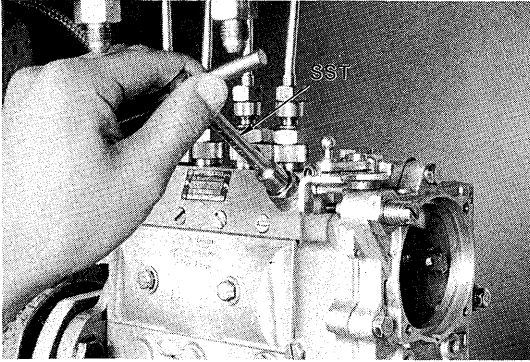

12. Bleed air from pump housing.

Fig. 6-167

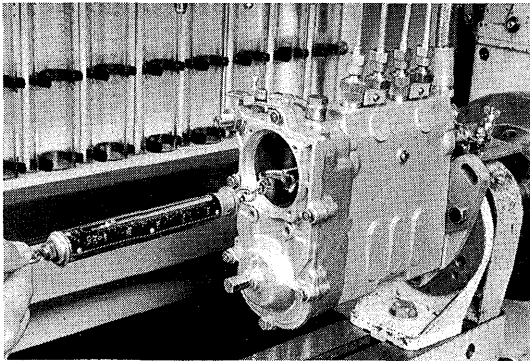

Control Rack Sliding Resistance

Measure the control rack sliding resistance with a spring scale (spring balancer).

Pump revolution	Sliding resistance
0 rpm	Less than 120 g (4.2 oz)
1,000 rpm	Less than 50 g (1.8 oz)

Fig. 6-168

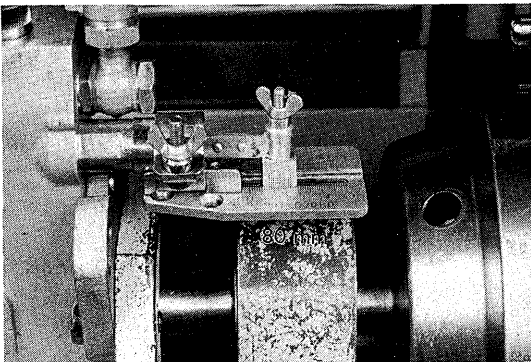

Adjust Injection Timing

1. Pre-stroke (for No.1 plunger)
 - (1) Set the control rack position at 8.0 mm (0.315 in.).

Fig. 6-169

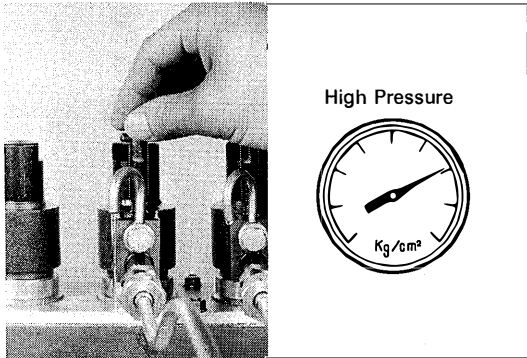

- (2) Loosen the overflow cock of the pump tester bench nozzle holder.
- (3) Fuel feeding pressure to injection pump should be on the high side.

Fig. 6-170

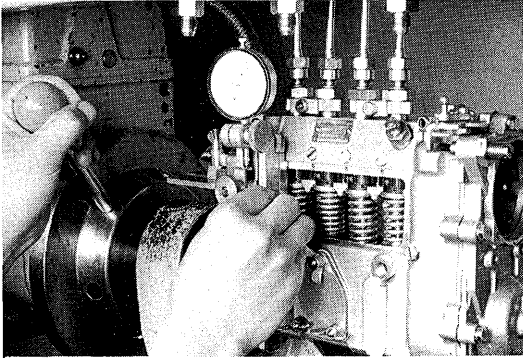

- (4) Using SST, set the No.1 tappet to BDC position, and set the dial gauge on No.1 tappet.
SST (09283-46010) of set
[09260-46011]

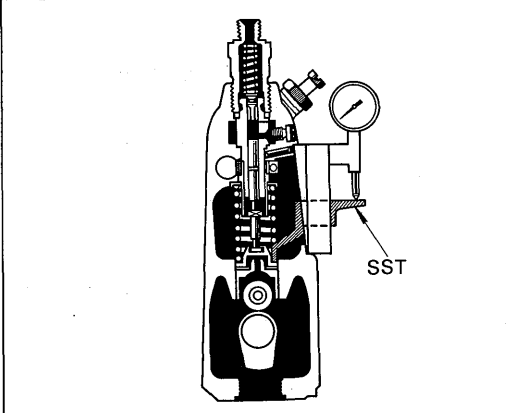
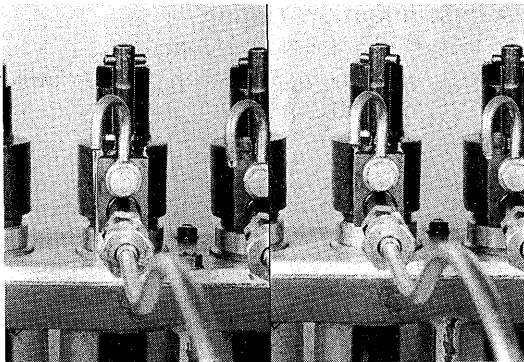

Fig. 6-171



- (5) Rotate the camshaft clockwise, and measure the lift of No.1 plunger when the plunger moves from BDC to injection starting position (To the point where fuel flowing from the overflow pipe stops.)

Pre-stroke:

1.9 – 2.0 mm

(0.075 – 0.079 in.)

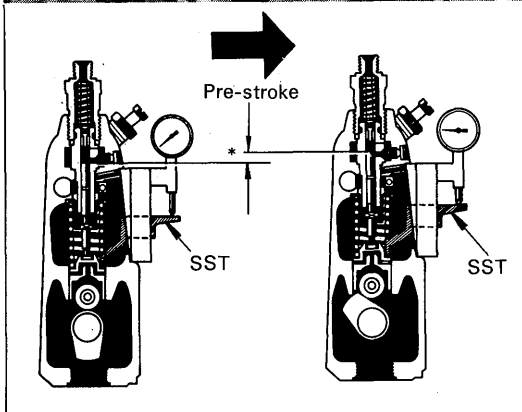
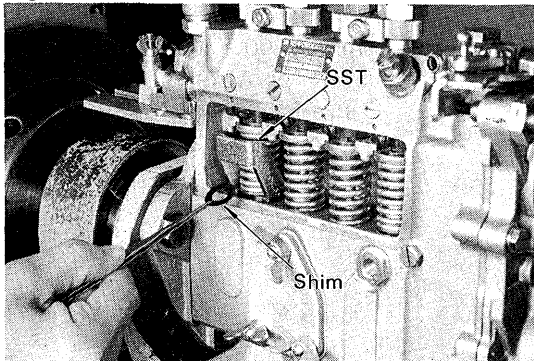

Fig. 6-172



- (6) If the pre-stroke is not within specification, use SST and adjust by changing the tappet adjusting shim. SST (09280-46010) of set [09260-46011]

-Note-

15 shims are available, each varying in thickness by 0.1 mm (0.004 in.) from 0.1 – 1.4 mm (0.004 – 0.055 in.) and 0.15 mm (0.006 in.).

Fig. 6-173

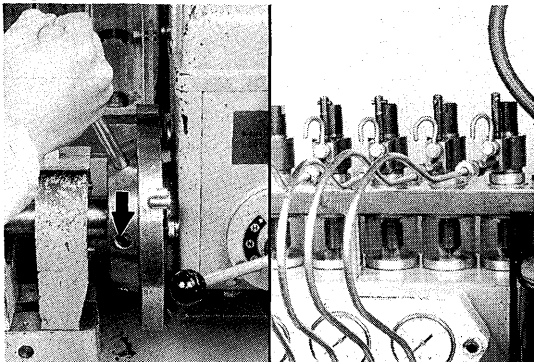

2. Injection Interval

- (1) Using No.1 cylinder injection starting time position as a base, inspect and adjust the injection starting angles in the order of injection.
- (2) Injection starting angle.

Cylinder No.	Injection starting angle
1	0
3	89° 30' – 90° 30'
4	179° 30' – 180° 30'
2	269° 30' – 270° 30'

Fig. 6-174

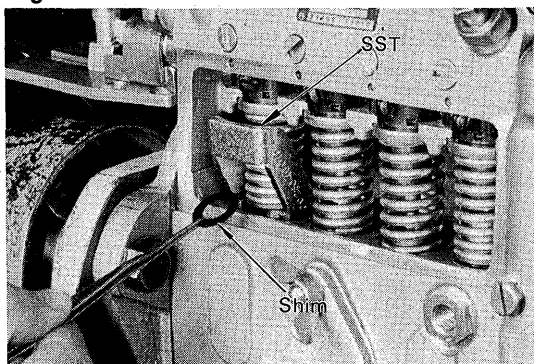

- (3) If the injection starting angles are not within specification, adjust by using the same procedure as for pre-stroke adjustment.

Fig. 6-175

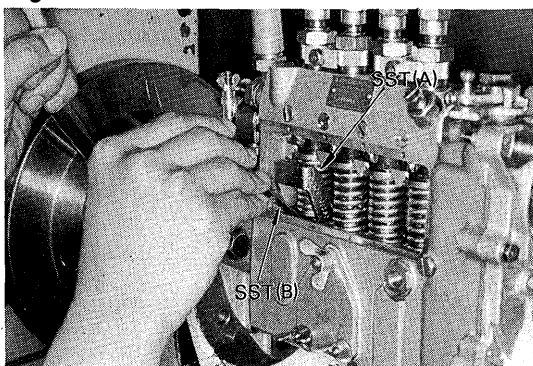

3. Tappet Clearance

- (1) Using SST (A), insert the 0.2 mm (0.008 in.) gauge of SST (B) between the spring lower seat and adjusting shim, and rotate the camshaft slowly.
SST (A) (09280-46011) of set [09260-46011]
(B) [09288-46011]
- (2) The camshaft should turn easily.

Tappet clearance:

**More than 0.2 mm
(0.008 in.)**

Fig. 6-176

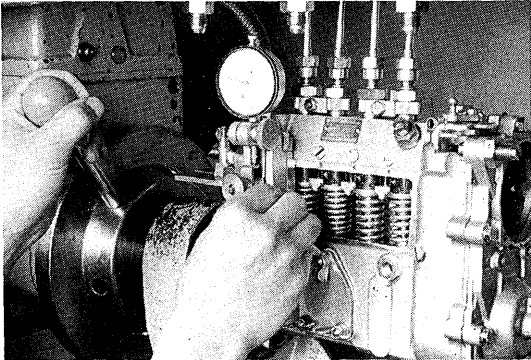

- (3) If the tappet clearance is less than 0.2 mm (0.008 in.), recheck and adjust the pre-stroke.

Pre-stroke:

**1.9 – 2.0 mm
(0.075 – 0.079 in.)**

Fig. 6-177

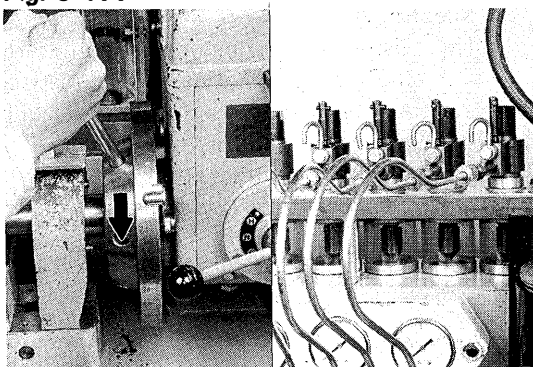

- (4) Recheck and adjust the injection starting angle.

Cylinder No.	Injection starting angle
1	0
3	89° 30' – 90° 30'
4	179° 30' – 180° 30'
2	269° 30' – 270° 30'

Fig. 6-178

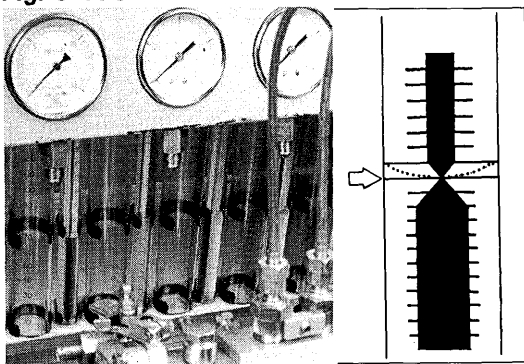

Adjust Injection Volume

1. Before measuring the injection volume, operate the injection pump lever two or three times in order to stabilize the injection volume.
2. Measure the injection volume for each control rack position and pump revolution.

For B Engine

Rack Position mm (in.)	Pump rpm	Measuring Strokes	Injection Volume cc (cu in.)	Variation Limit cc (cu in.)
16.0 (0.630)	100	200	14.0 – 16.0 (0.85 – 0.98)	1.2 (0.07)
11.7 (0.461)	1,100	200	10.0 – 10.6 (0.61 – 0.65)	0.4 (0.02)
8.6 (0.339)	1,000	200	4.6 – 5.6 (0.28 – 0.34)	0.4 (0.02)
6.5 (0.256)	325	500	2.5 – 4.5 (0.15 – 0.27)	1.0 (0.06)

For 2B Engine

Rack Position mm (in.)	Pump rpm	Measuring Strokes	Injection Volume cc (cu in.)	Variation Limit cc (cu in.)
16.0 (0.630)	100	200	14.0 – 16.0 (0.85 – 0.98)	1.2 (0.07)
11.9 (0.469)	1,100	200	11.0 – 11.6 (0.67 – 0.71)	0.4 (0.02)
8.0 (0.315)	1,000	200	4.3 – 5.1 (0.26 – 0.31)	0.4 (0.02)
6.5 (0.256)	325	500	2.5 – 4.5 (0.15 – 0.27)	1.0 (0.06)

For 3B Engine

Rack Position mm (in.)	Pump rpm	Measuring Strokes	Injection Volume cc (cu in.)	Variation Limit cc (cu in.)
17.5 (0.689)	100	200	14.0 – 16.0 (0.85 – 0.98)	1.2 (0.07)
13.0 (0.512)	1,100	200	11.3 – 11.9 (0.69 – 0.73)	0.4 (0.02)
13.0 (0.512)	1,700	200	11.5 – 12.5 (0.70 – 0.76)	0.6 (0.04)
8.0 (0.315)	1,000	200	4.3 – 5.1 (0.26 – 0.31)	0.4 (0.02)
6.5 (0.256)	325	500	2.5 – 4.5 (0.15 – 0.27)	1.0 (0.06)

Fig. 6-179

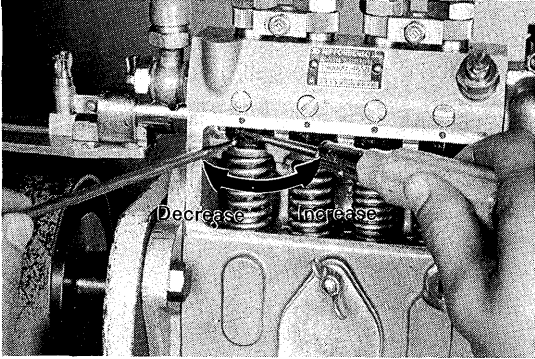

2. To adjust the injection volume, loosen the pinion clamp screw and rotate the control sleeve.

ASSEMBLY (COMBINED GOVERNOR)

Assemble the parts in the numerical order shown in the figure.

Fig. 6-180

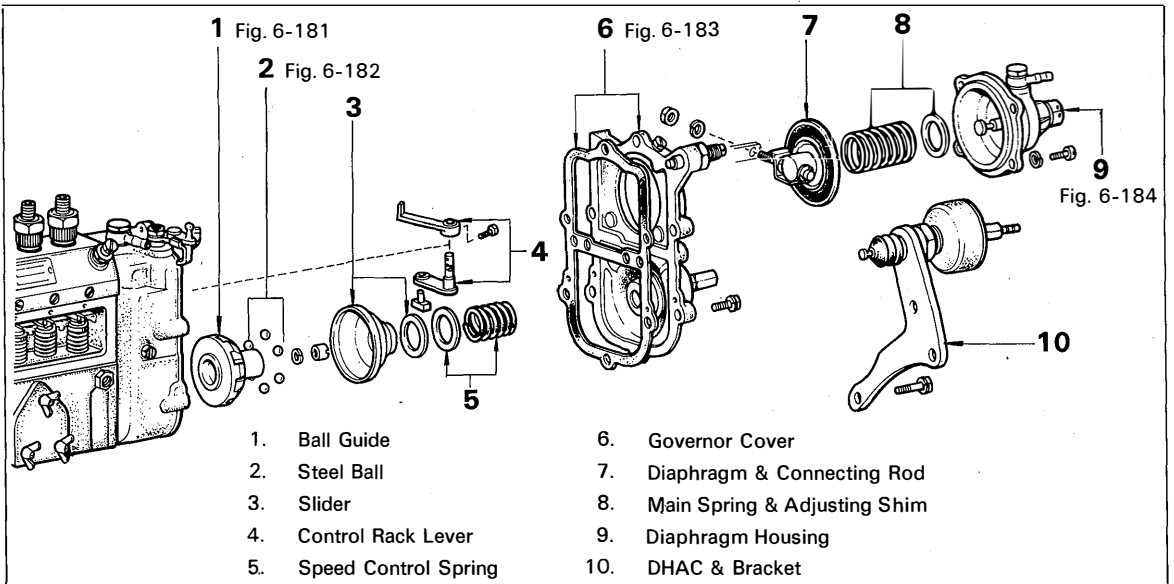
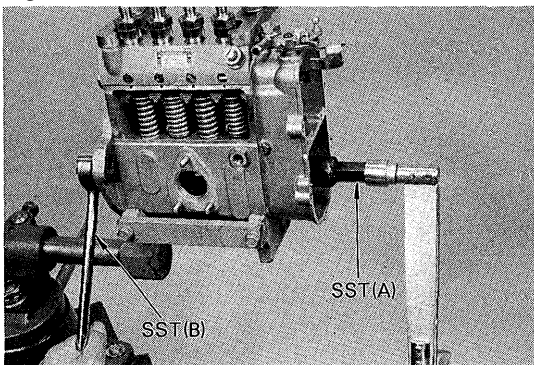

Fig. 6-181



Hold the spline shaft with SST (B) and tighten the round nut with SST (A).

SST (A) (09266-67011) of set [09260-76016]

(B) (09278-46010) of set [09260-46011]

**Tightening torque: 5.0 – 6.0 kg-m
(37 – 43 ft-lb)**

Fig. 6-182

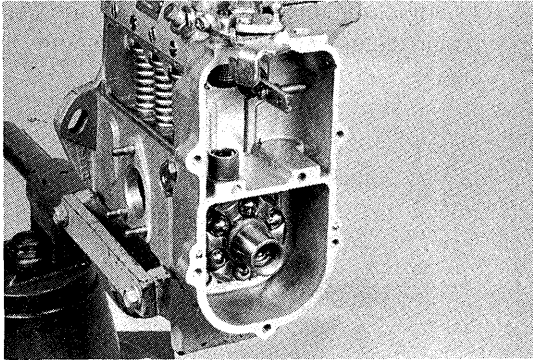

Apply grease to the ball guide groove and put six steel balls in the groove.
Place slider onto the ball guide.

Fig. 6-183

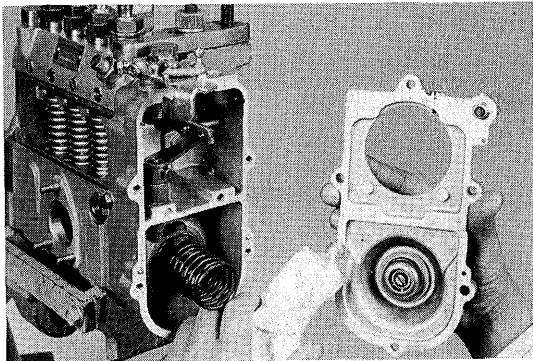

Lightly coat liquid sealer on the new governor cover gasket before installing.

Fig. 6-184

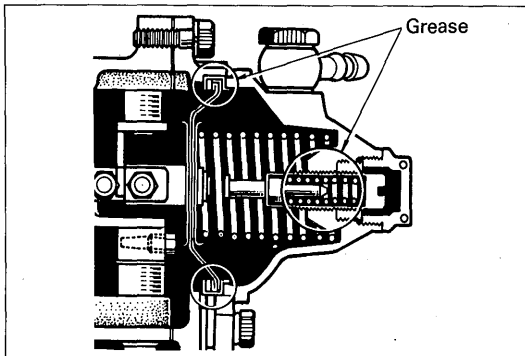

Coat the diaphragm housing and idling capsule with grease to keep the vacuum chamber airtight.

**ADJUSTMENT
(COMBINED GOVERNOR)
Combined Governor Characteristic
Diagram (For B Engine)**

Fig. 6-185

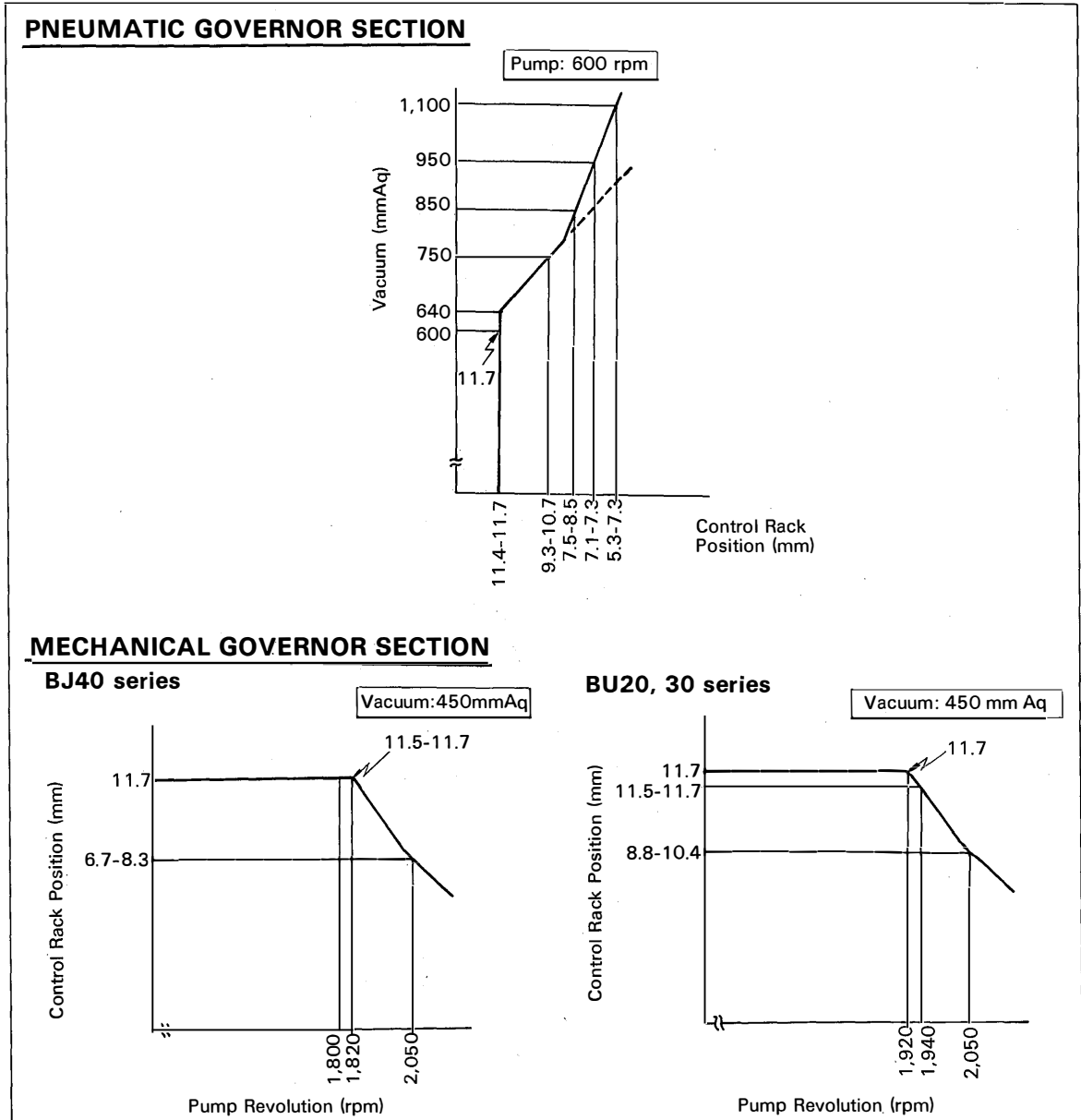

Total Injection Volume (For B Engine)

Model	Measuring strokes	Pump revolution	Vacuum	Total injection volume
BJ40	500	1,100 rpm	150 mm Aq (5.91 in. Aq)	101.0 – 105.0 cc (6.16 – 6.41 cu in.)
BU20, 30	500	1,100 rpm	120 mm Aq (4.72 in. Aq)	101.0 – 105.0 cc (6.16 – 6.41 cu in.)

Combined Governor Characteristic Diagram (For 2B Engine)

Fig. 6-186

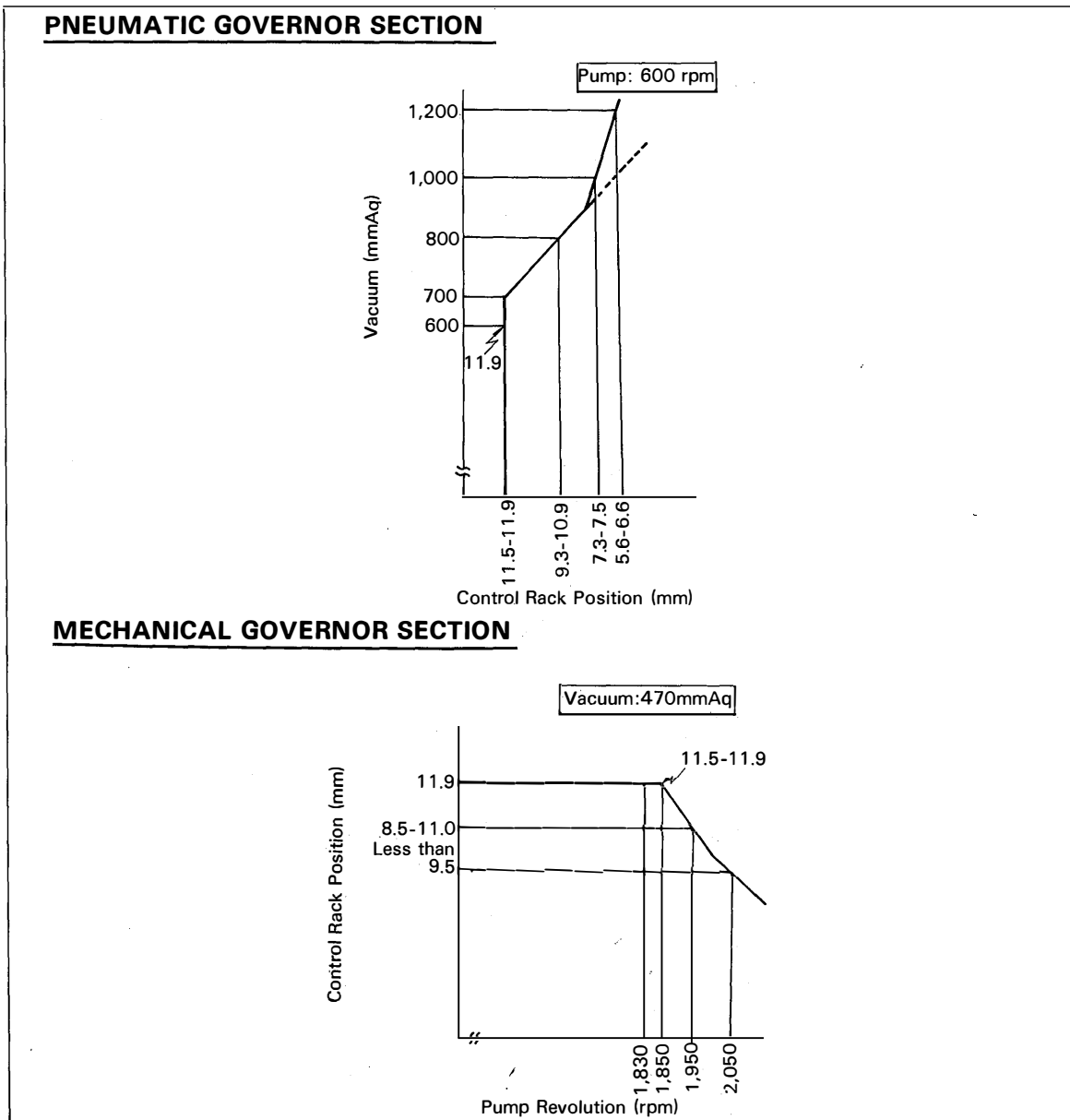

Total Injection Volume (For 2B Engine)

Measuring strokes	Pump revolution	Vacuum	Total injection volume
500	1,100 rpm	200 mm Aq (7.87 in. Aq)	106.0 – 110.0 cc (6.47 – 6.71 cu in.)

Combined Governor Characteristic Diagram (For 3B Engine)

Fig. 6-187

PNEUMATIC GOVERNOR SECTION

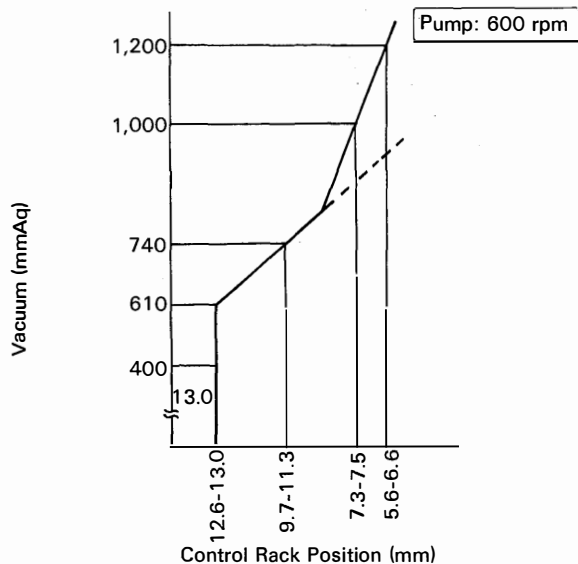

MECHANICAL GOVERNOR SECTION

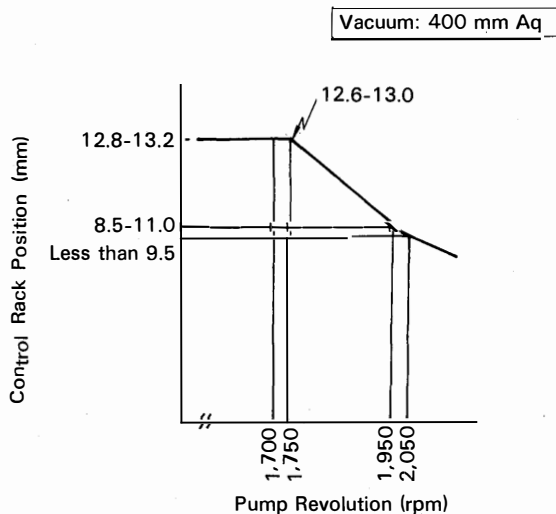

Total Injection Volume (For 3B Engine)

Measuring strokes	Pump revolution	Vacuum	Total injection volume
500	1,100 rpm	260 mm Aq (10.24 in. Aq)	114.0 – 118.0 cc (6.96 – 7.20 cu in.)

Fig. 6-188

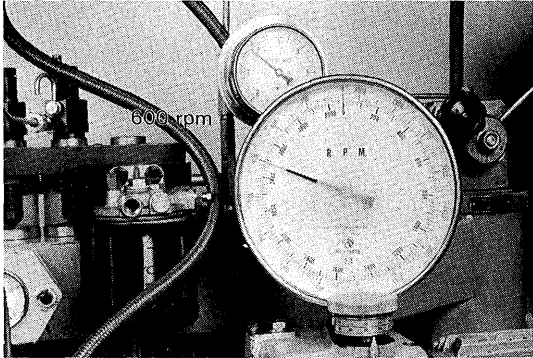

Test Airtightness

1. Set the injection pump revolution at 600 rpm.

Fig. 6-189

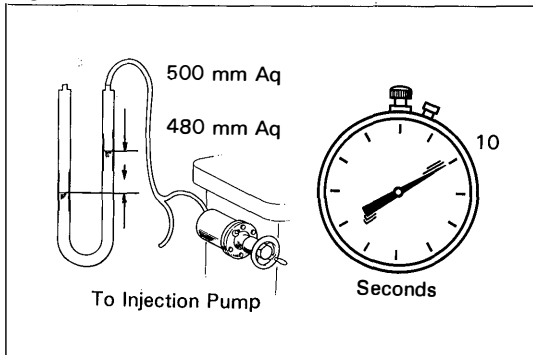

2. Measure the time it takes the vacuum chamber to reduce its vacuum to 480 mmAq (18.90 in.Aq).

Vacuum loss	Time
From 500 mm Aq to 480 mmAq (19.69 in.Aq) (18.90 in.Aq)	More than 10 seconds

3. Retighten the diaphragm housing and inspect the diaphragm if airtightness is unsatisfactory.

Fig. 6-190

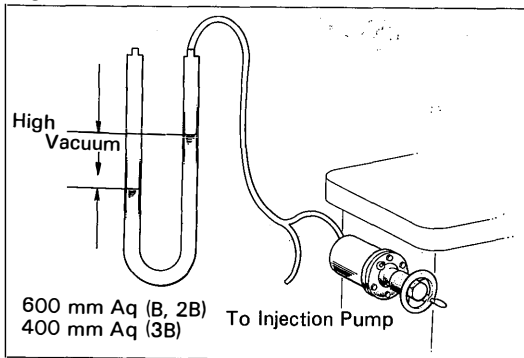

Adjust Initial Set of Control Rack

1. Set the vacuum to specified value.

—Note—

When altering the vacuum, set to the specified value after altering largely, and read graduation when it becomes steady.

Fig. 6-191

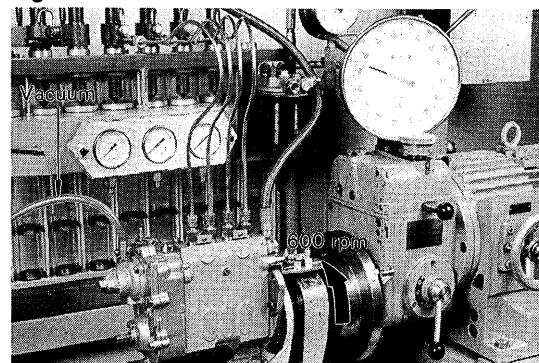

2. Check the initial set point of the control rack.

Model	Pump revolution (rpm)	Vacuum mm Aq (in.Aq)	Control rack position mm (in.)
B	600	600 (23.62)	11.7 (0.461)
2B	600	600 (23.62)	11.9 (0.469)
3B	600	400 (15.75)	13.0 (0.512)

Fig. 6-192

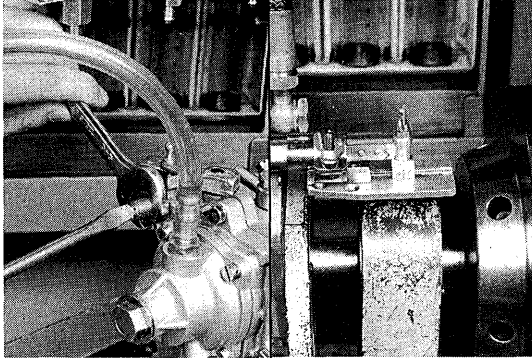

Fig. 6-193

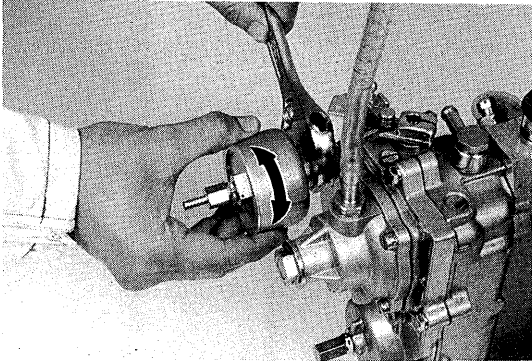

Fig. 6-194

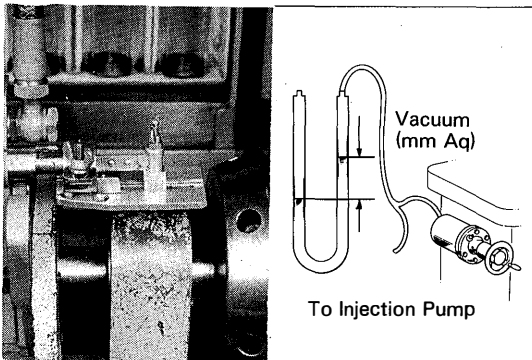
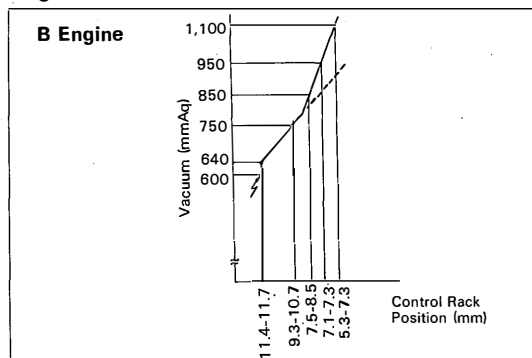

Fig. 6-195



- Adjust the initial set of the control rack by turning the full stop capsule.

- If the governor is equipped with a Diesel High Altitude Compensator (DHAC) instead of full stop capsule, adjust it.



Adjust Main Spring

- Check the control rack position.
- Adjust the control rack position by increasing the number of main spring shims.

Shim thickness:

0.5, 1.0, 2.0, 3.0 mm

(0.020, 0.039, 0.079, 0.118 in.)

-Note-

To increase rack position.

Increase shim thickness.

To decrease rack position.

Decrease shim thickness.

Engine model	Pump revolution (rpm)	Vacuum mmAq (in.Aq)	Rack position mm (in.)
B	600	640 (25.20)	11.4 - 11.7 (0.449 - 0.461)
		750 (29.53)	9.3 - 10.7 (0.366 - 0.421)

Fig. 6-196

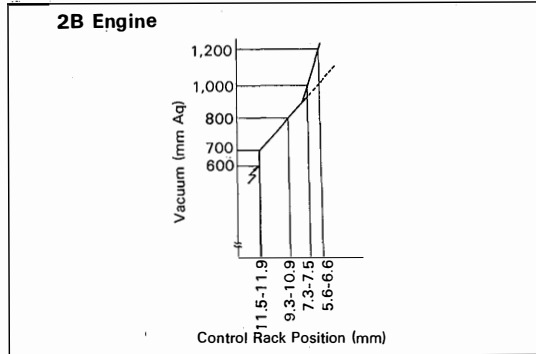

Engine model	Pump revolution (rpm)	Vacuum mmAq (in.Aq)	Rack position mm (in.)
2B	600	700 (27.56)	11.5 - 11.9 (0.453 - 0.469)
		800 (31.50)	9.3 - 10.9 (0.336 - 0.409)

Fig. 6-197

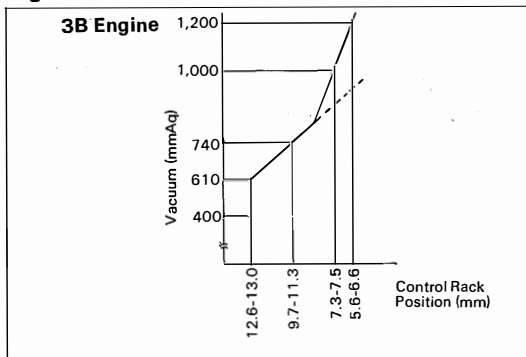

Engine model	Pump revolution (rpm)	Vacuum mmAq (in.Aq)	Rack position mm (in.)
3B	600	610 (24.02)	12.6 - 13.0 (0.496 - 0.512)
		740 (29.13)	9.7 - 11.3 (0.382 - 0.445)

Fig. 6-198

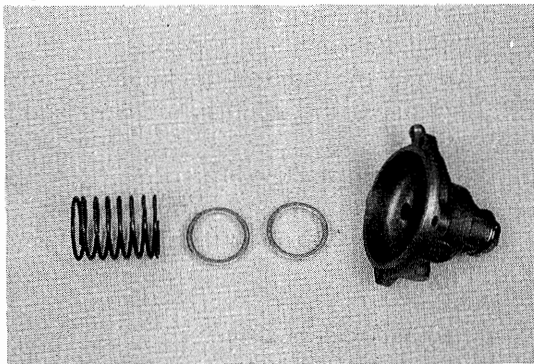

- If the control rack position is not within specification, check the main spring.

Free length: B & 2B 45.6 mm (1.795 in.)
3B 51.6 mm (2.031 in.)

Fig. 6-199

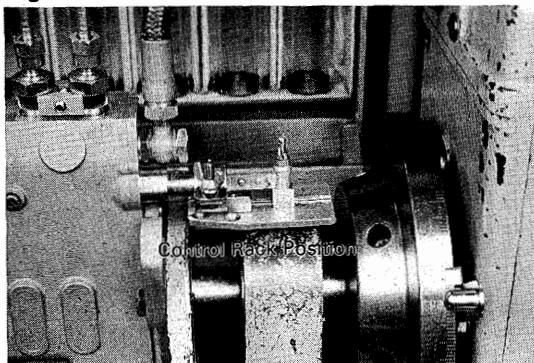

- When adjustment is completed, reconfirm the initial setting.

Initial set of control rack

Engine model	Pump revolution (rpm)	Vacuum mmAq (in.Aq)	Control rack position mm (in.)
B	600	600 (23.62)	11.7 (0.461)
2B	600	600 (23.62)	11.9 (0.469)
3B	600	400 (15.75)	13.0 (0.512)

Fig. 6-200

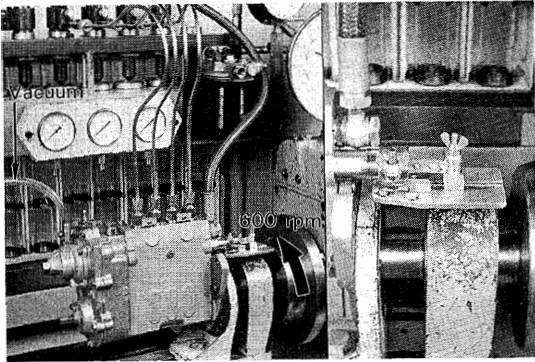

Adjust Idling Spring Capsule

1. Check the control rack position.

Engine model	Pump revolution (rpm)	Vacuum mm Aq (in.Aq)	Control rack position mm (in.)
B	600	850 (33.46)	7.5 - 8.5 (0.295 - 0.335)
		950 (37.40)	7.1 - 7.3 (0.280 - 0.287)
		1,100 (43.31)	5.3 - 7.3 (0.209 - 0.287)
2B	600	1,200 (47.24)	5.6 - 6.6 (0.220 - 0.260)
		1,000 (39.37)	7.3 - 7.5 (0.287 - 0.295)
3B	600	1,000 (39.37)	7.3 - 7.5 (0.287 - 0.295)
		1,200 (47.24)	5.6 - 6.6 (0.220 - 0.260)

Fig. 6-201

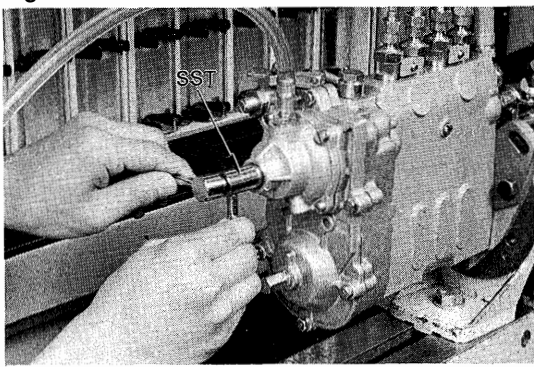

2. Using SST, adjust the control rack position by turning the idling capsule.
SST (09282-76010) of set [09260-76016]

Fig. 6-202

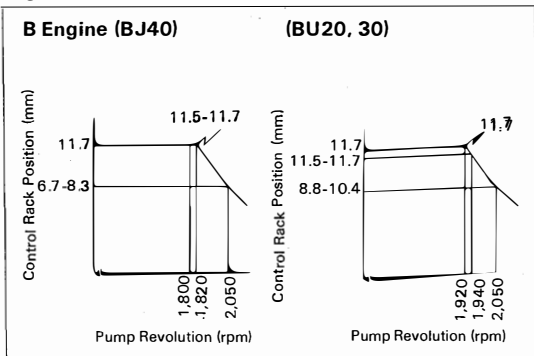

Adjust Mechanical Governor Section

1. Set the vacuum to specified value.
2. Check the control rack position.



Engine model	Vacuum mm Aq (in.Aq)	Pump revolution (rpm)	Control rack position mm (in.)
B (BJ40)	450 (17.72)	1,800	11.7 (0.461)
		1,820	11.5 - 11.7 (0.453 - 0.461)
		2,050	6.7 - 8.3 (0.264 - 0.327)
B (BU20, 30)	450 (17.72)	1,920	11.7 (0.461)
		1,940	11.5 - 11.7 (0.453 - 0.461)
		2,050	8.8 - 10.4 (0.346 - 0.409)
2B	470 (18.50)	1,830	11.9 (0.469)
		1,850	11.5 - 11.9 (0.453 - 0.469)
		1,950	8.5 - 11.0 (0.335 - 0.433)
		2,050	Less than 9.5 (0.374)

Fig. 6-203

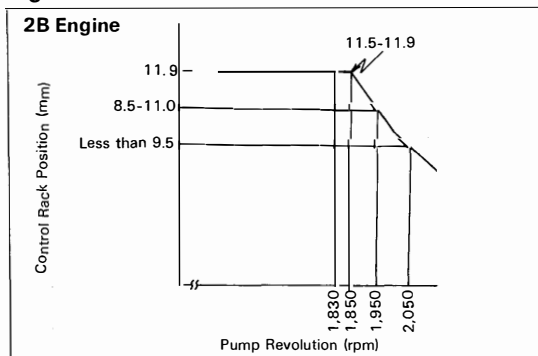
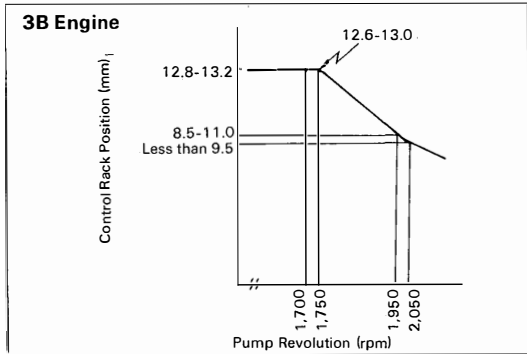
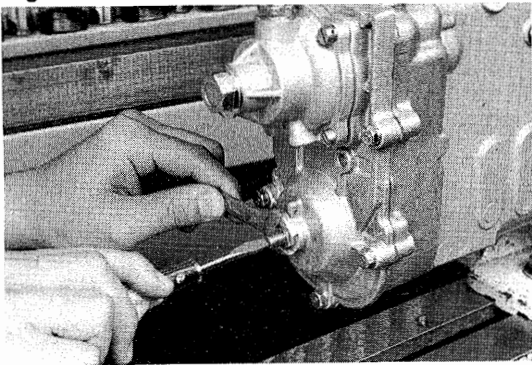

Fig. 6-204



Engine model	Vacuum mm Aq (in.Aq)	Pump revolution (rpm)	Control rack position mm (in.)
3B	400 (15.75)	1,700	12.8 - 13.2 (0.504 - 0.520)
		1,750	12.6 - 13.0 (0.496 - 0.512)
		1,950	8.5 - 11.0 (0.335 - 0.433)
		2,050	Less than 9.5 (0.374)

Fig. 6-205



- Adjust the control rack position by turning the speed control screw.

Fig. 6-206

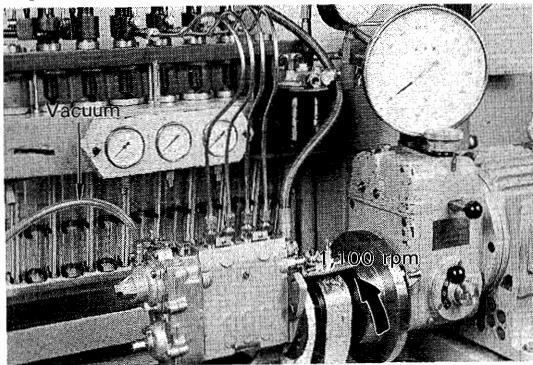
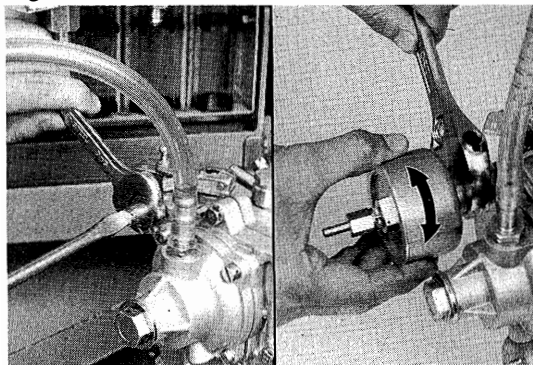

Fig. 6-207



Total Injection Volume

- Before measuring the injection volume, operate the injection pump lever two or three times in order to stabilize the injection volume.
- Measure the total injection volume at 500 strokes.

Engine model	Pump revolution (rpm)	Vacuum mm Aq (in.Aq)	Total injection volume cc (cu in.)
B (BJ40)	1,100	150 (5.91)	101.0 - 105.0 (6.16 - 6.41)
B (BU20, 30)	1,100	120 (4.72)	101.0 - 105.0 (6.16 - 6.41)
2B	1,100	200 (7.87)	106.0 - 110.0 (6.47 - 6.71)
3B	1,100	260 (10.24)	114.0 - 118.0 (6.96 - 7.20)

- If the total injection volume is not within specification, adjust it by turning full stop capsule or Diesel High Altitude Compensator (DHAC).

INSTALLATION

Install the parts in the numerical order shown in the figure.

Fig. 6-208

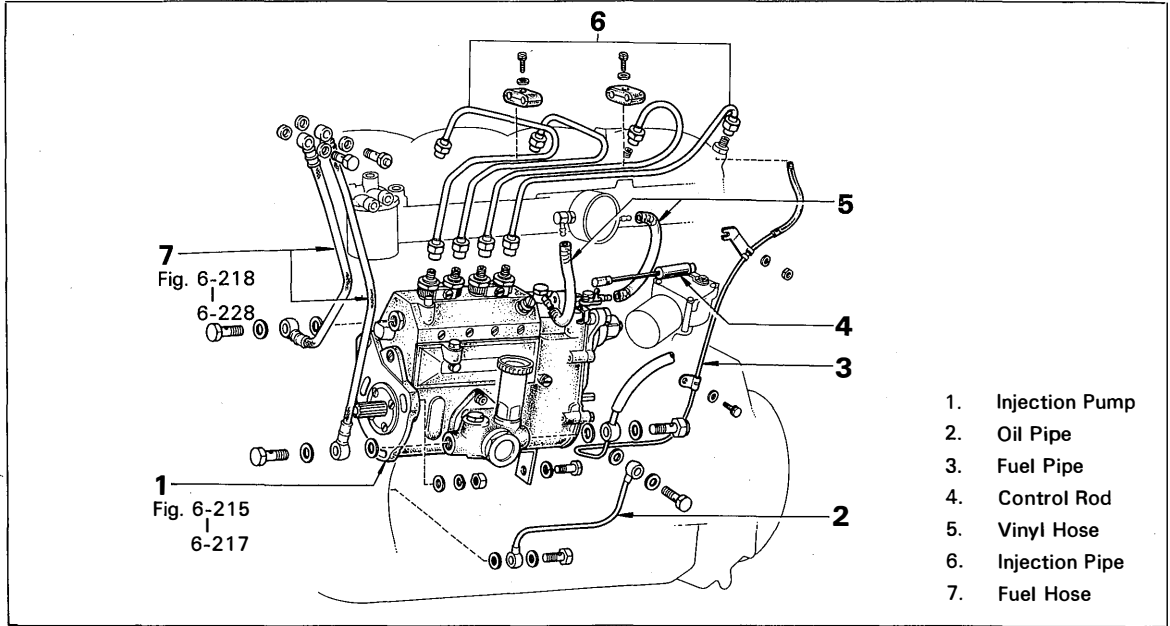
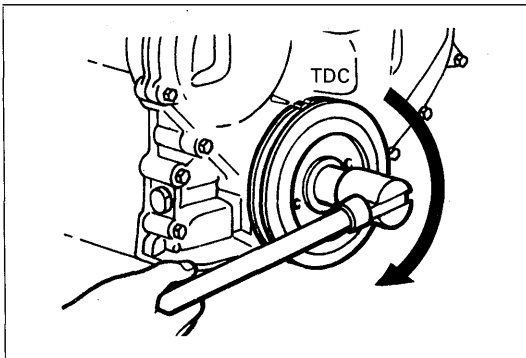
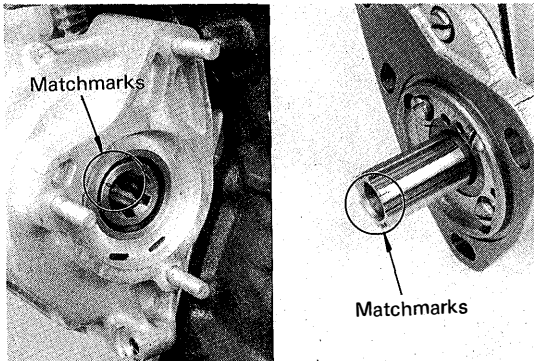

Fig. 6-209



Set the No.1 cylinder piston at TDC/compression.

Fig. 6-210



Align the matchmarks on the injection pump spline shaft and timer drive shaft when installing the injection pump.



—Note—
Coat MP grease on the splines.

Fig. 6-211

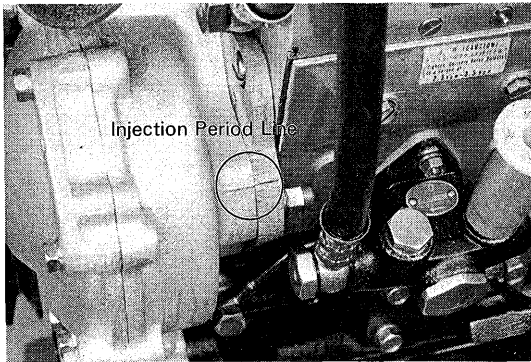

Set the injection period line to the former position.

Fig. 6-212

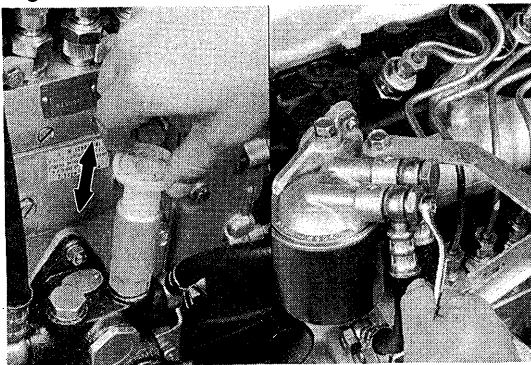

Bleed the air from fuel system after installation is completed.

- (1) Loosen the fuel filter bleeder plug and operate the priming pump until there is no air emission from the filter.
- (2) Tighten the fuel filter bleeder plug.

—Note—

Be careful that fuel does not splash on the radiator hose.

Fig. 6-213

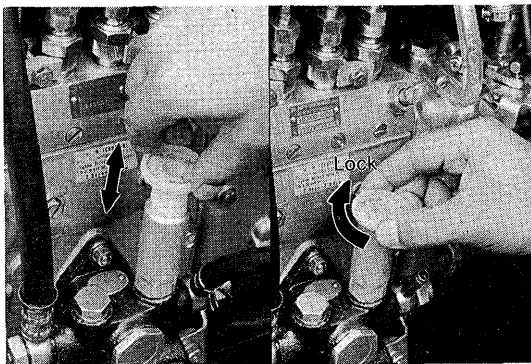

- (3) Loosen the injection pump bleeder plug and operate the priming pump until there is no air emission from the injection pump.
- (4) Screw in the priming pump handle and lock it.

—Note—

Be sure to lock the priming pump handle prior to the tightening the injection pump bleeder plug.

Fig. 6-214



- (5) Tighten the injection pump bleeder plug.

Fig. 6-215

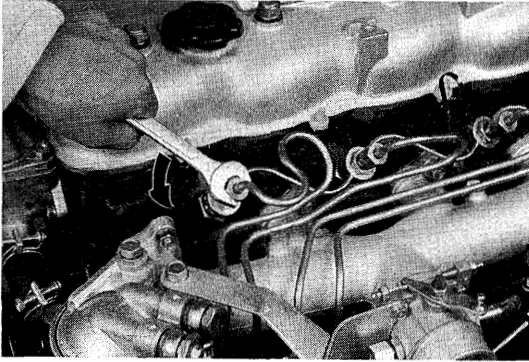

- (6) Loosen all union nuts of the injection pipe on the nozzle holder side.

Fig. 6-216

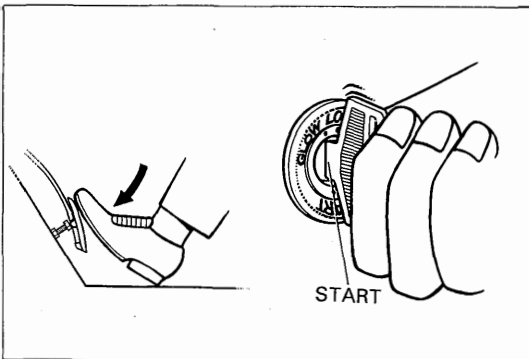

- (7) Turn the engine with the accelerator pedal fully depressed.

Fig. 6-217

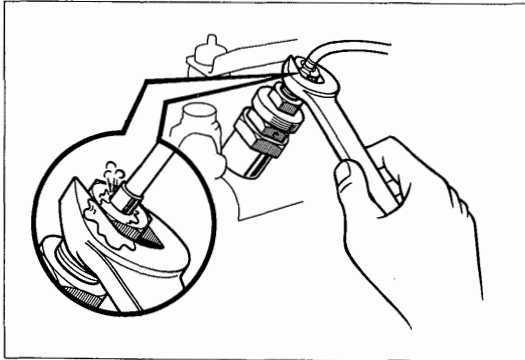

- (8) Crank the engine to bleed the air and force out the fuel from injection pipe.

Tightening torque:

**2.0 – 3.0 kg-m
(15 – 21 ft-lb)**

—Note—

Start the engine and inspect all pipe lines for fuel leaks.

Fig. 6-218

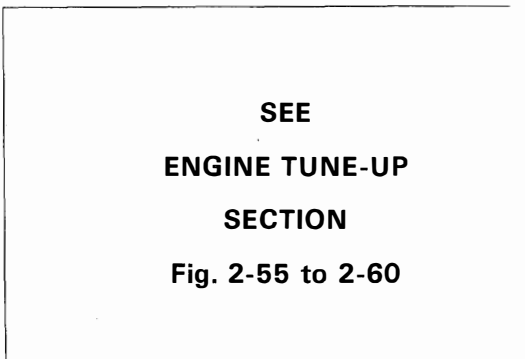

Check the engine idle speed and maximum speed.

EDIC (ELECTRICAL DIESEL INJECTION CONTROL) SYSTEM

	Page
OPERATING DIAGRAM	7-2
EDIC SYSTEM CIRCUIT	7-2
OPERATIONAL CHECK	7-3
FUEL CONTROL MOTOR	7-4

OPERATING DIAGRAM

Fig. 7-1

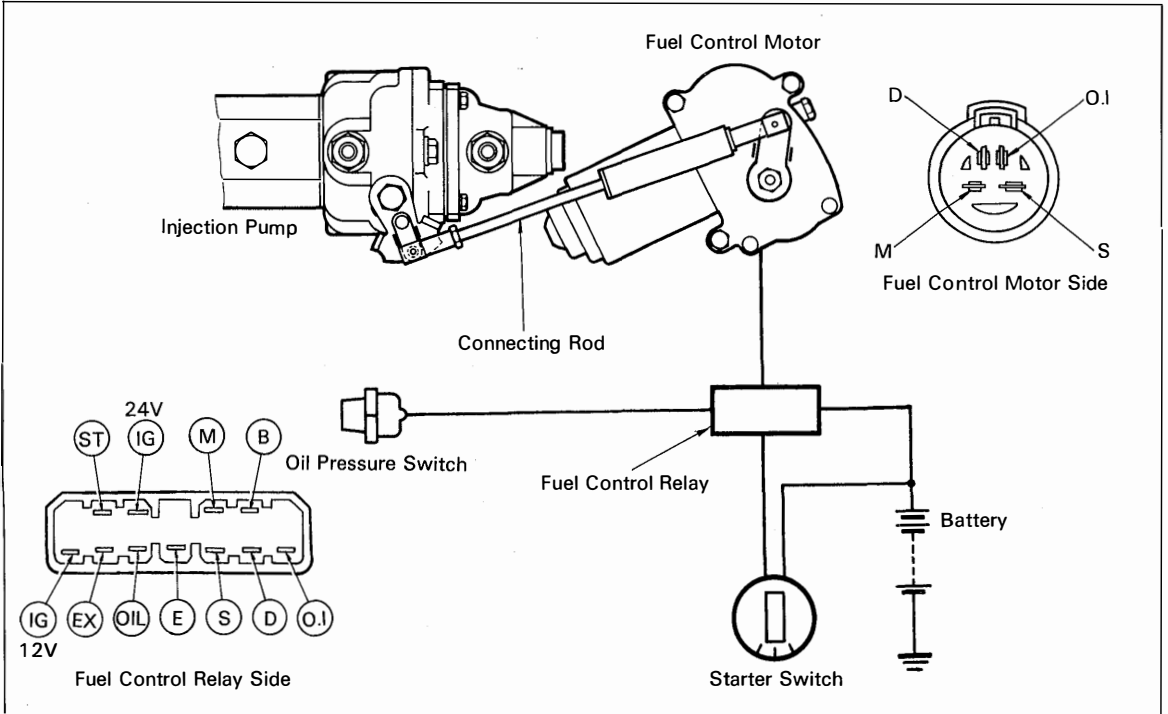

EDIC SYSTEM CIRCUIT

Fig. 7-2

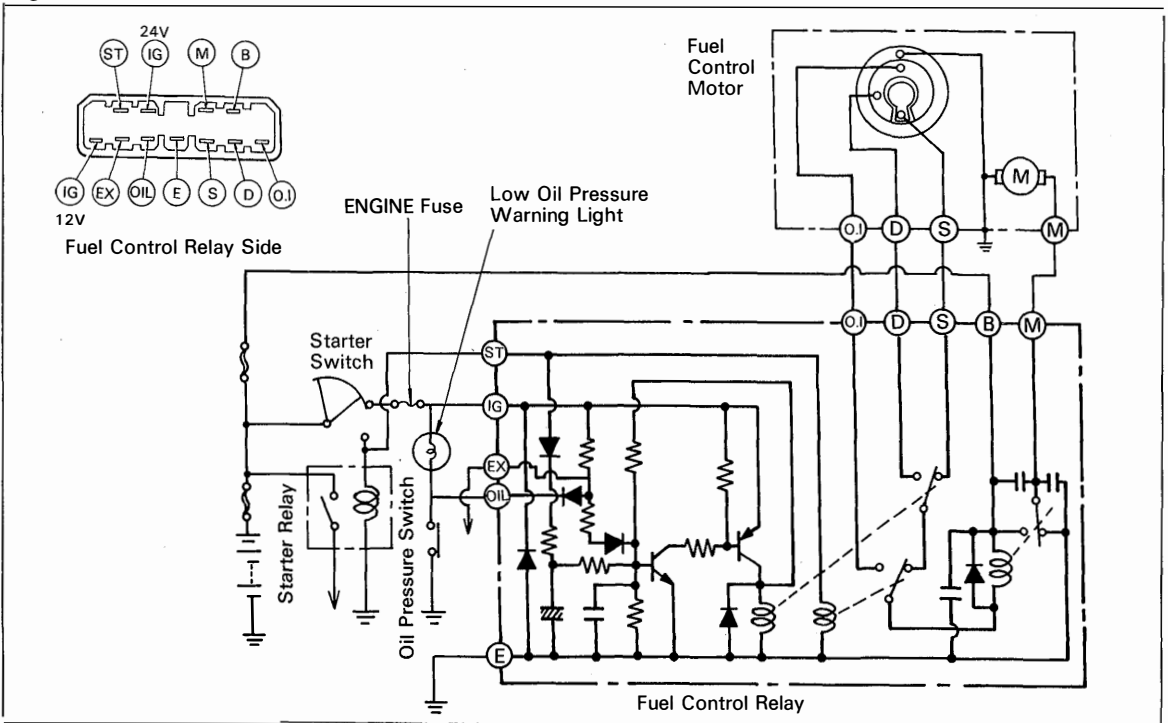
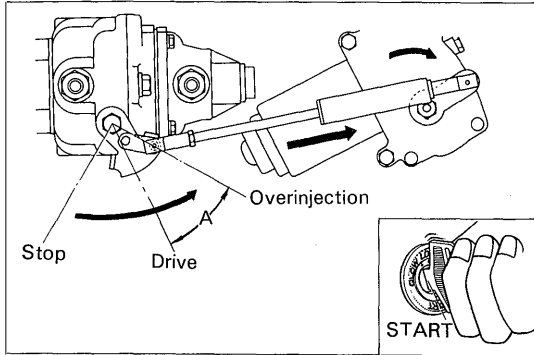

Fig. 7-3



OPERATIONAL CHECK



STARTING OVERINJECTION

When the starter is turned to "START", the injection pump lever should move to the over-injection position.

- A:** 41°
35° (w/ DHAC)

Fig. 7-4

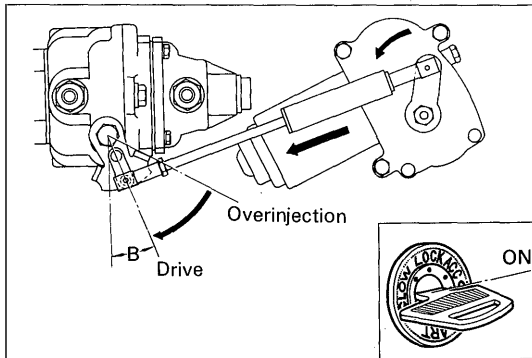

AFTER STARTING (DRIVE POSITION)

After starting the engine, the fuel control motor lever and the injection pump lever should be positioned between the two marks.

- B:** B, 2B Engine 19.5°
3B Engine 22.5°

Fig. 7-5

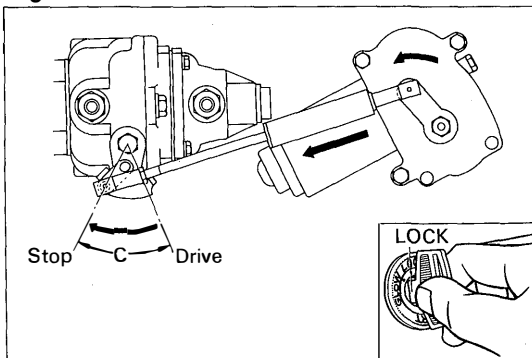

ENGINE STOP

When the starter switch is turned to "LOCK", the injection pump lever should move to the stop position and the engine should stop.

- C:** B, 2B Engine 49°
3B Engine 52°

Fig. 7-6

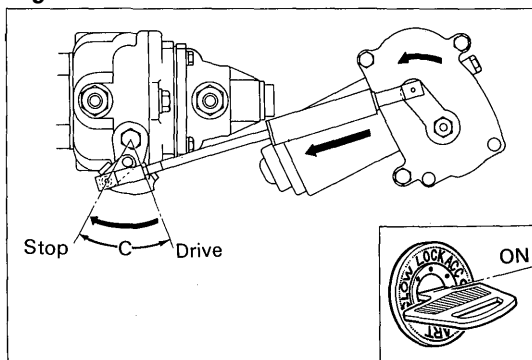

REVERSE ROTATION PREVENTION

Start the engine, and ground the oil pressure switch connector.

Then, the injection pump lever should move to the stop position and the engine should stop.

Fig. 7-7

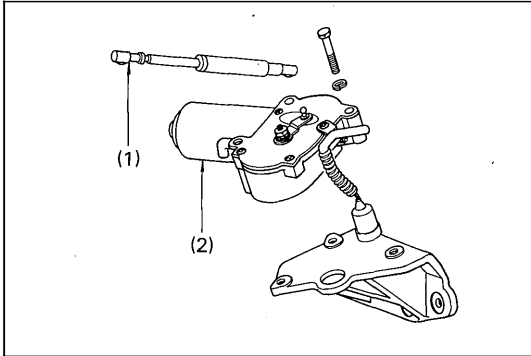

Fig. 7-8

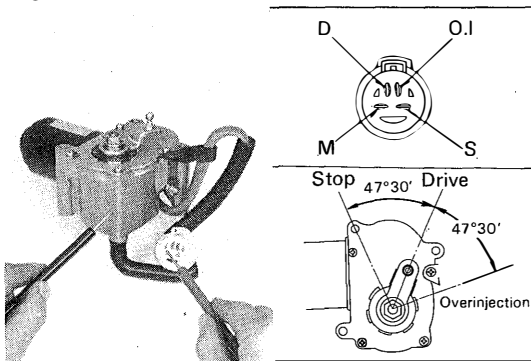

Fig. 7-9

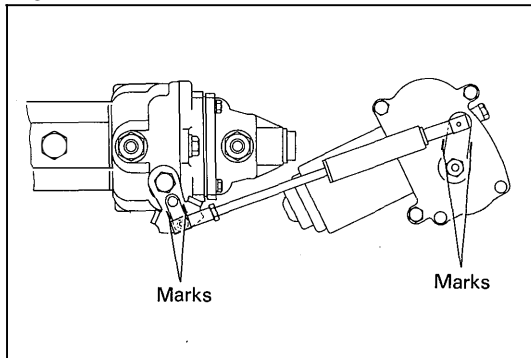
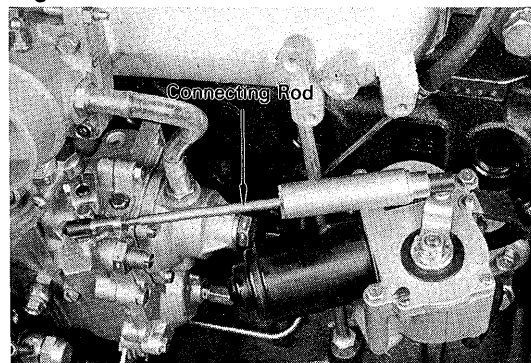

Fig. 7-10



FUEL CONTROL MOTOR

REMOVAL



Remove the connecting rod (1) and fuel control motor (2).

INSPECTION



1. Measure resistance between terminal M and body.

Resistance:

12V type About 0.8Ω

24V type About 3.3Ω

2. Check the continuity between D,S and O.I terminals at each motor lever position.

Motor lever position \ Terminal	S	D	O.I
Stop position		○—○	○—○
Drive position	○—○		○—○
Overinjection position	○—○	○—○	



INSTALLATION

1. Install the motor and connecting rod in reverse order of removal.

—Note—

The fuel control motor lever and injection pump lever should be positioned between the two marks.



2. Adjust the connecting rod length if necessary.

STARTING SYSTEM

	Page
STARTING SYSTEM CIRCUIT	8-2
PREHEATING SYSTEM	8-4
STARTER RELAY & OVERINJECTION MAGNET ...	8-7
STARTER	8-8

STARTING SYSTEM CIRCUIT For BJ60

Fig. 8-1

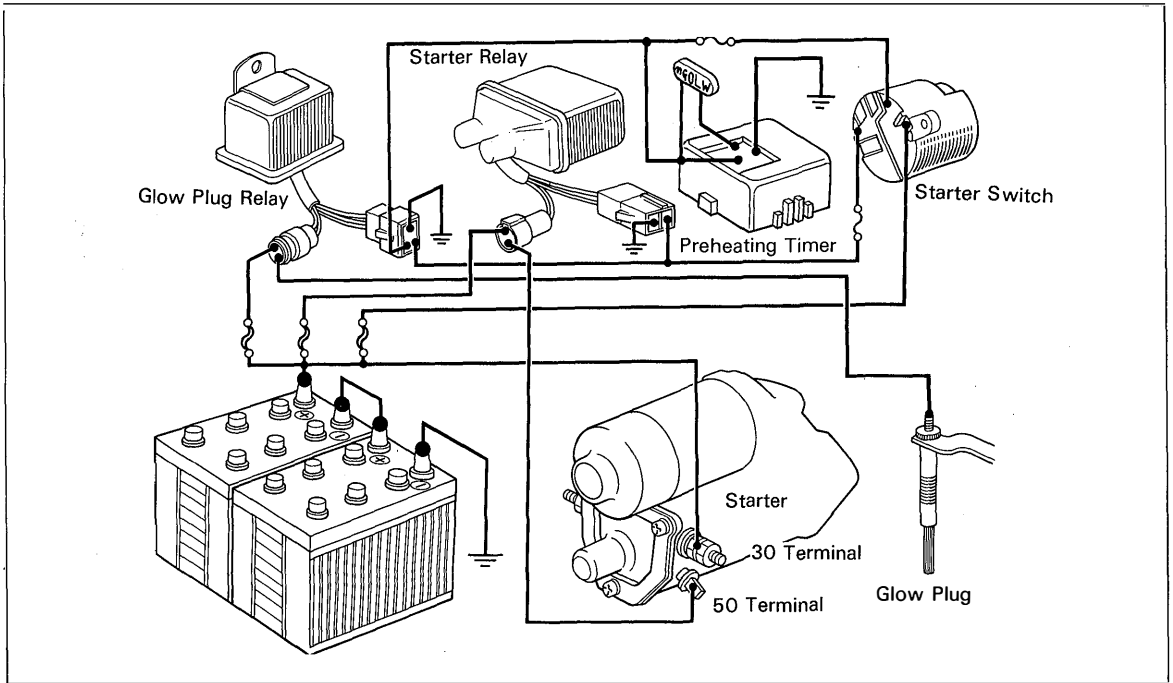
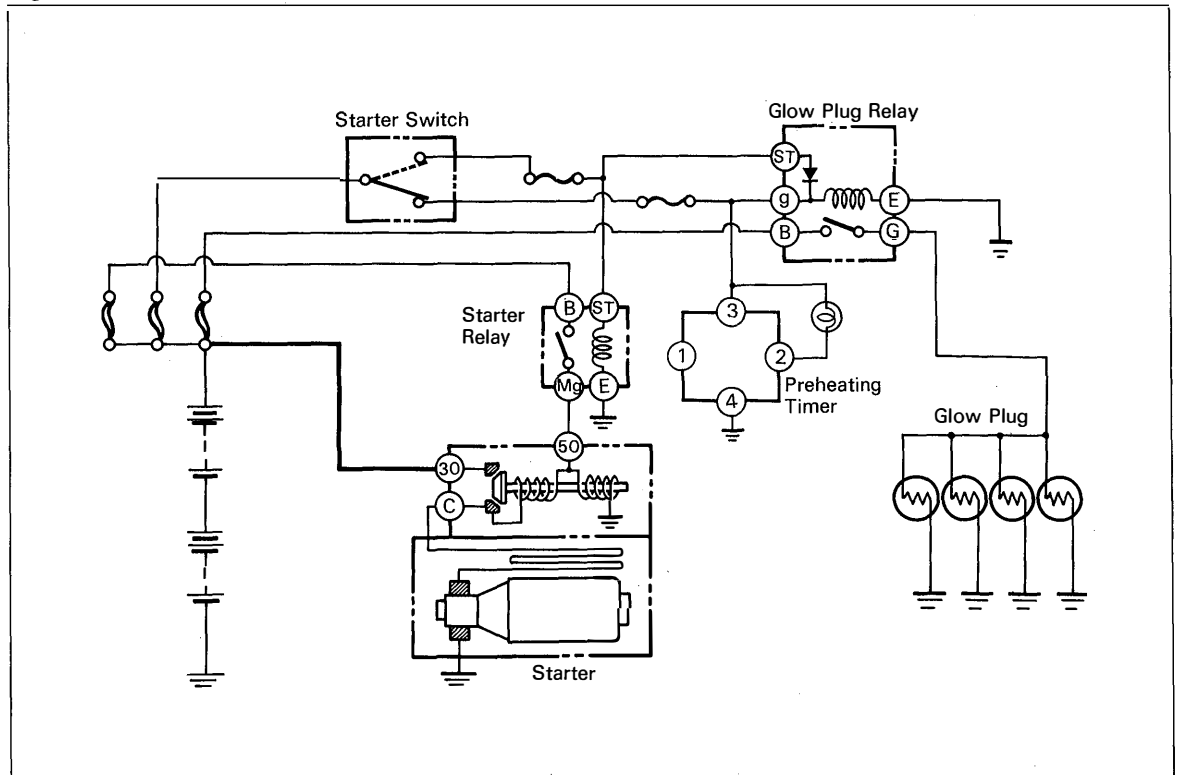

Fig. 8-2



Except BJ60

Fig. 8-3

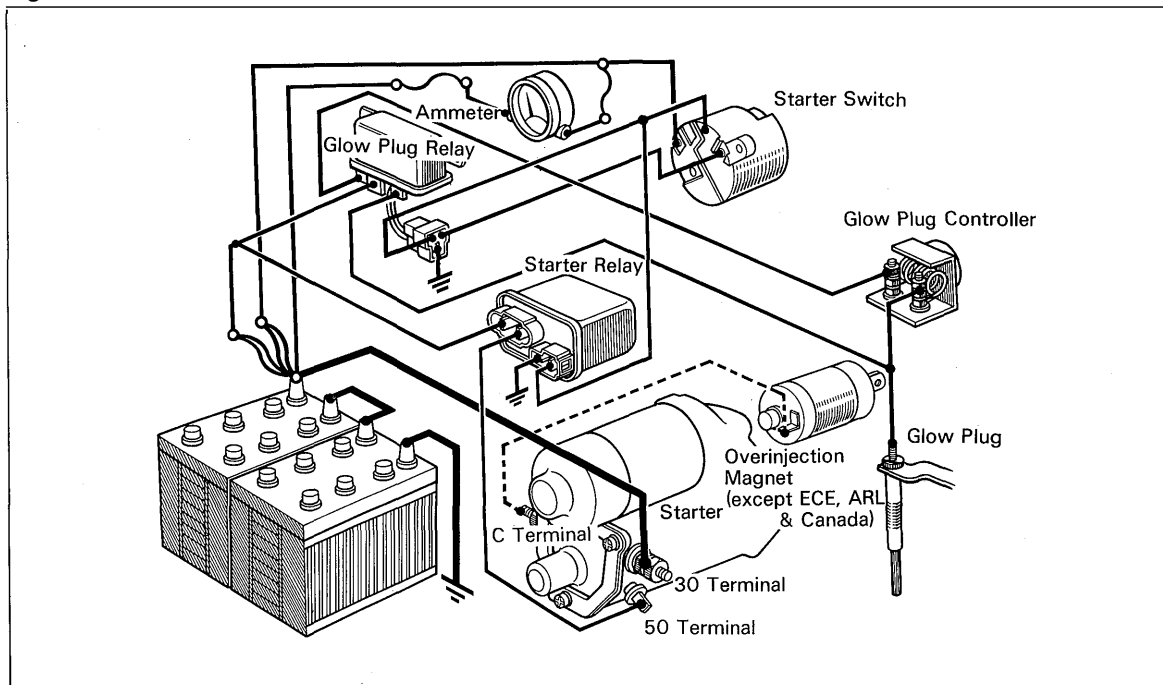

Fig. 8-4

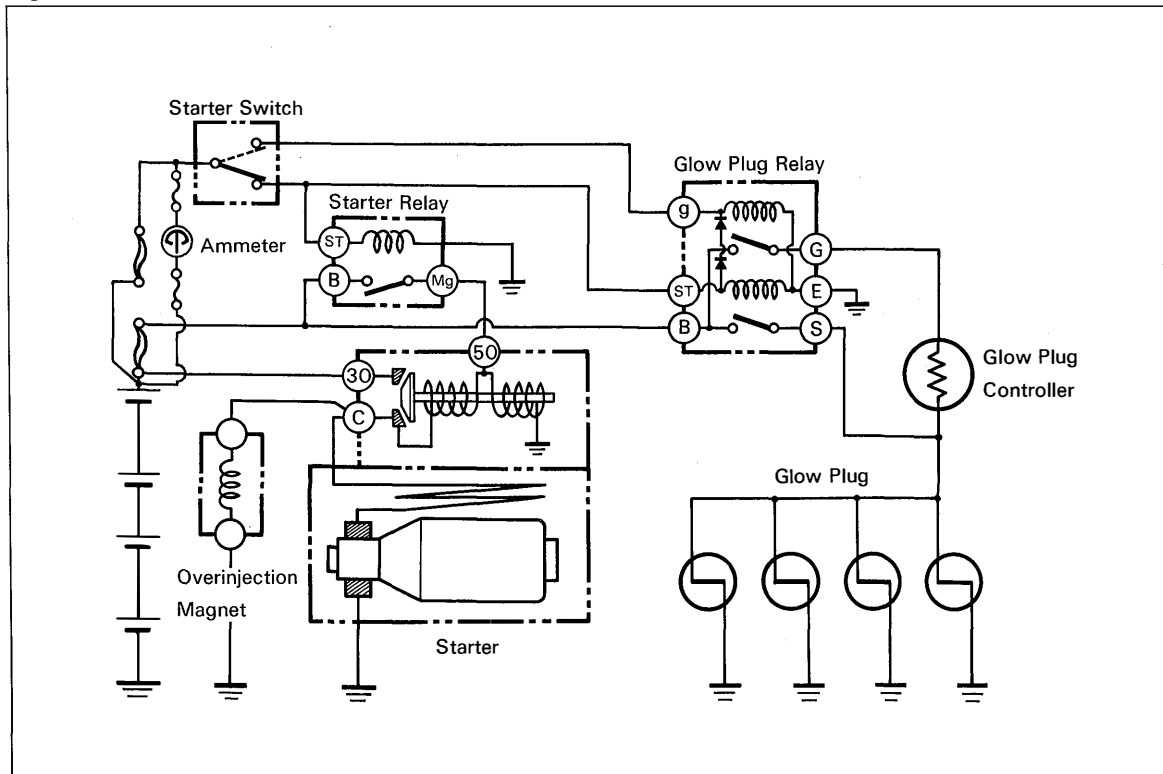
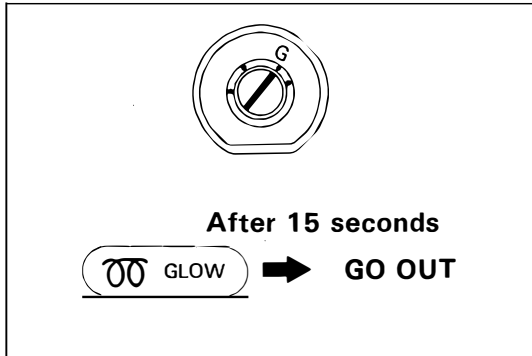

Fig. 8-5



PREHEATING SYSTEM



INSPECTION

Preheating Timer (for BJ 60)

1. With the starter switch in G position, check to see how long it takes for the glow light to go out.

Glow time at 0°C (32°F)

About 15 seconds

Fig. 8-6

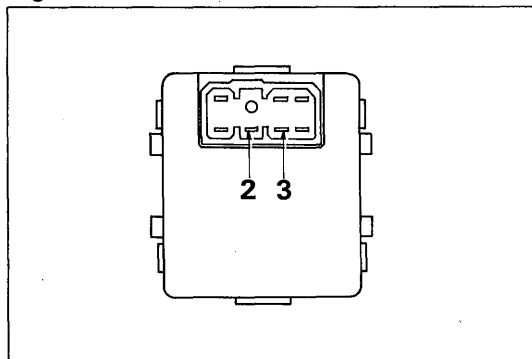

2. When the engine is started with the timer in operation, check to see that the continuity to 2nd and 3rd terminals of preheating timer is broken.

Fig. 8-7

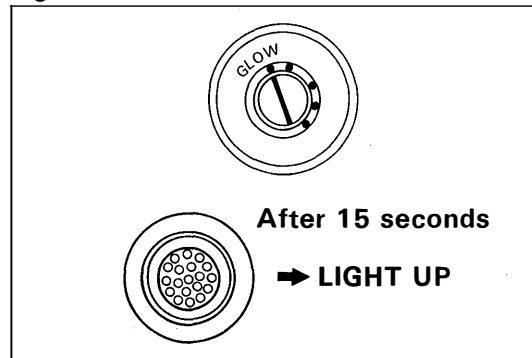

Glow Plug Controller (except BJ 60)

1. With the starter switch in GLOW position, check to see how long it takes for the glow indicator to light up.

Glow time at 0°C (32°F)

About 15 seconds

Fig. 8-8

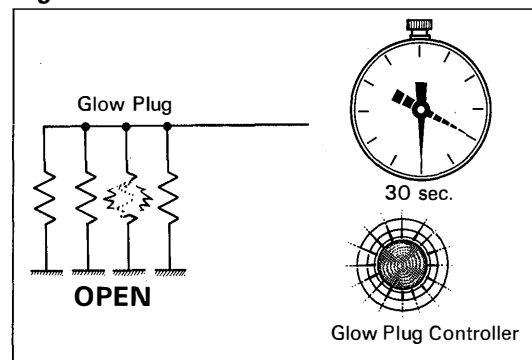

2. If glow time is more than 30 seconds, check the following conditions.

- (1) Open circuit in wiring
- (2) Loose terminal connection
- (3) Burnt switch or relay points
- (4) Open glow plug or controller

Fig. 8-9

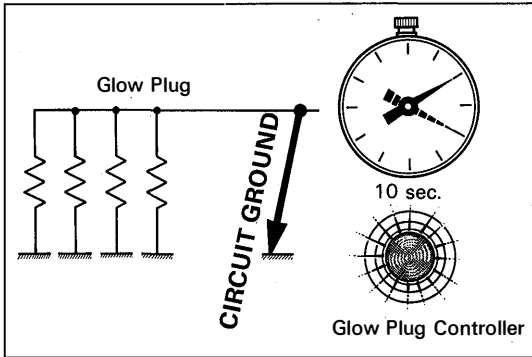

3. If glow time is less than 15 seconds, check the following conditions.
 - (1) Short circuit in wiring
 - (2) Shorted glow plug or controller

Fig. 8-10

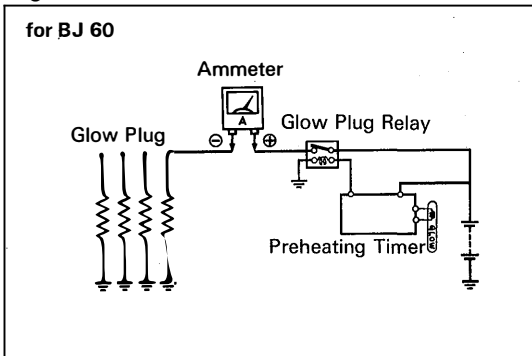

Load Current

1. Remove the glow plug connector.
2. Connect the ammeter between the glow plug lead wire and one glow plug.
3. Turn the starter switch to G (GLOW) position and measure the load current after about 40 seconds.

Load current per one glow plug:

BJ60 12V type 7.2 – 9.8A

24V type 3.8 – 5.2A

ex. BJ60

12V type 7.6 – 10.4A

24V type 4.1 – 5.5A

Fig. 8-11

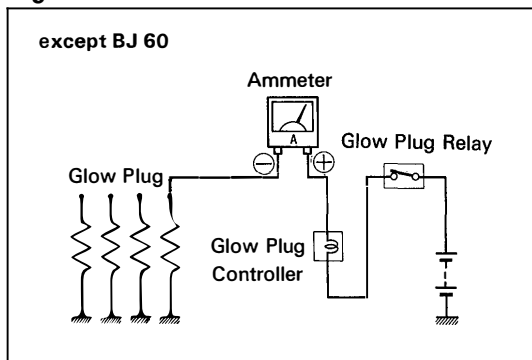

Glow Plug Resistance.

Measure the glow plug resistance.

Resistance at 20°C (68°F):

BJ60 12V type 1.2Ω

24V type 5.1Ω

ex. BJ60

12V type 0.9Ω

24V type 4.3Ω

Fig. 8-12

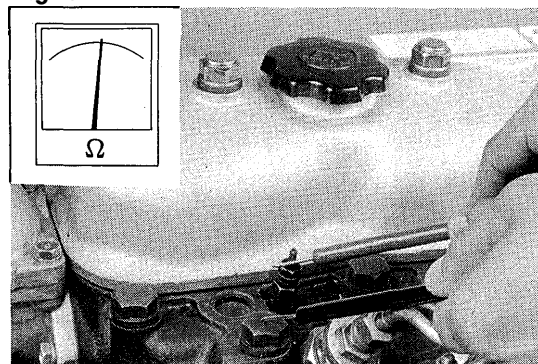

—Note—

1. Be careful not to damage the glow plug pipes.
This might cause open circuit or shorten life of the plugs.
2. Avoid getting oil and gasoline on the glow plug when cleaning.
3. After inspection, wipe oil off glow plug terminals and bakelite washer with a dry cloth.

Fig. 8-13

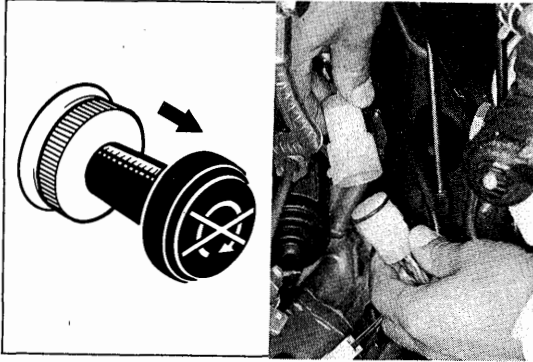
**Glow Plug Relay**

1. Pull the stop button all the way out or disconnect the connector of the EDIC motor wires to prevent accidental starting of the engine.

Fig. 8-14

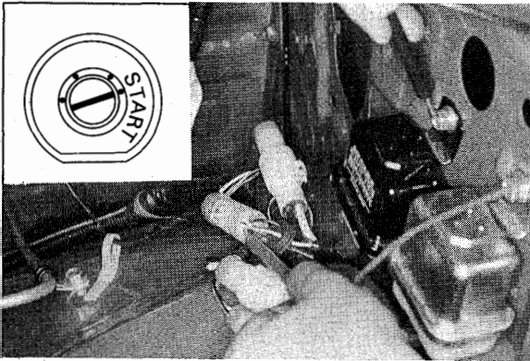

2. When the starter switch is turned to the START position, voltage should register at the ST terminal.

STARTER RELAY & OVERINJECTION MAGNET

Fig. 8-15

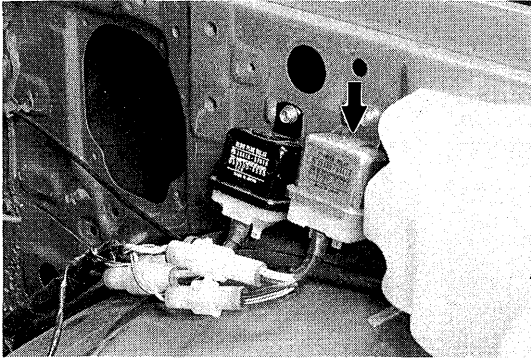

INSPECTION Starter Relay

Check the contact "click" noise when the starter switch is turned to the START position.

Fig. 8-16

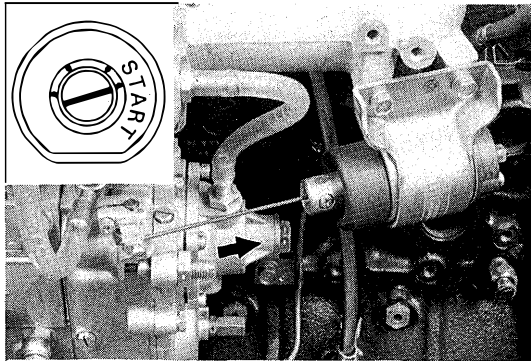

Overinjection Magnet (except for ECE, ARL & Canada)

Check to see if the injection pump lever moves to the overinjection position when the starter switch is turned to START position.

Fig. 8-17

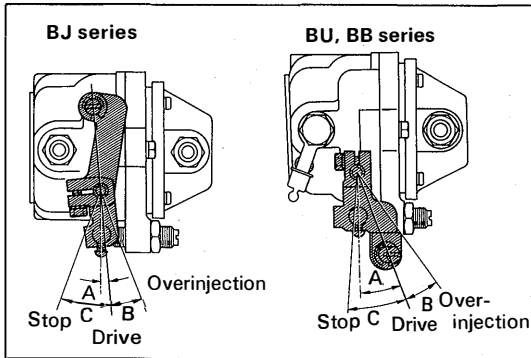

- A: 4.5° (BJ series)
20° (BU, BB series)
- B: 15°
- C: 25°

Fig. 8-18

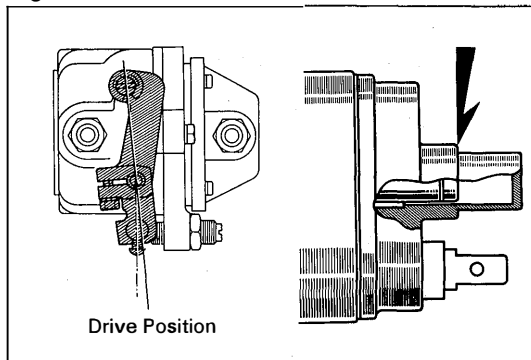

When connecting the overinjection magnet connecting wire, position the magnet core end surface as shown in the figure.

STARTER

CUTAWAY VIEW

Fig. 8-19

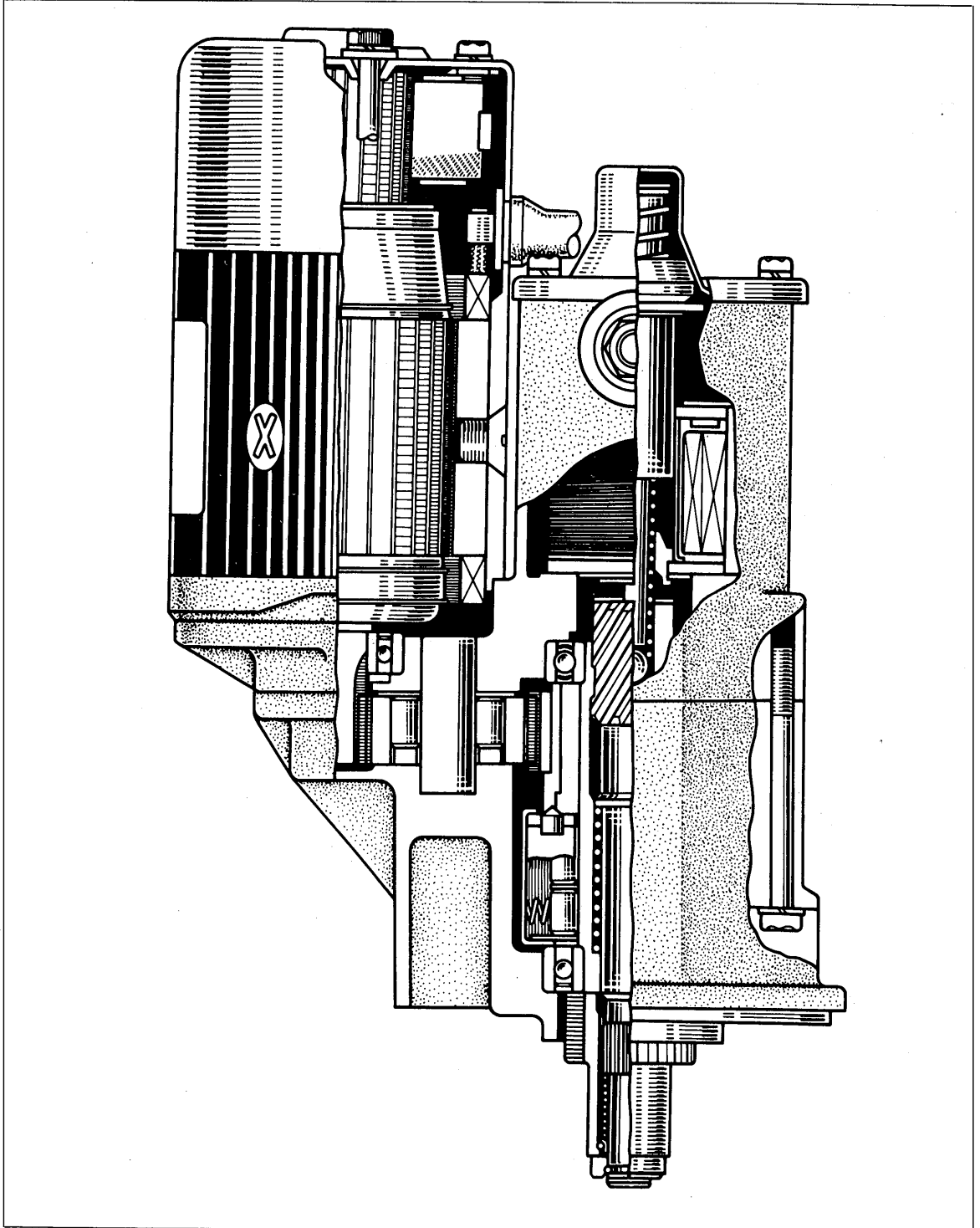

Fig. 8-20

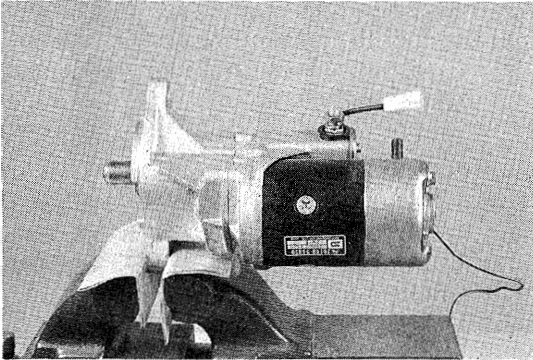

Fig. 8-21

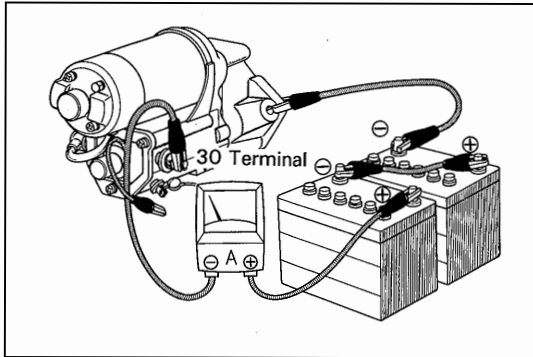

Fig. 8-22

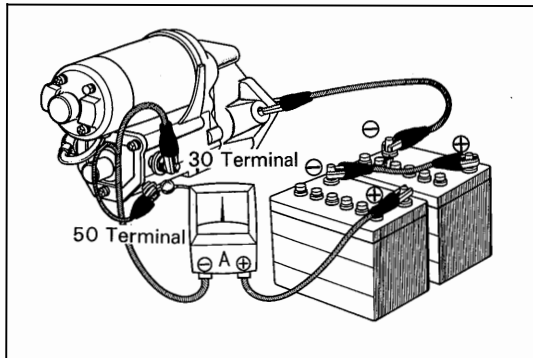
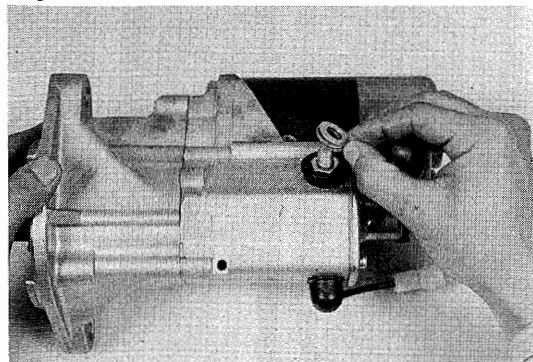

Fig. 8-23



PERFORMANCE TEST

No-Load Performance Test



1. Secure the starter in a vise to avoid an accident.



2. Connect the starter to battery as shown in the figure.

Positive side

Battery (+) → Ammeter (+)

Ammeter (-) → 30 Terminal

Negative side

Battery (-) → Starter housing



3. Connect the positive wire to the 50 terminal.

If the starter shows smooth and steady rotation with the pinion jumping out and drawing less than specified current, it is satisfactory.

Specified current:

12V type Less than 180A

24V type Less than 90A



Magnetic Switch Test

-Note-

Each test must be performed within a short time (3 - 5 seconds) to prevent the coil from burning out.

1. Disconnect terminal C.

Fig. 8-24

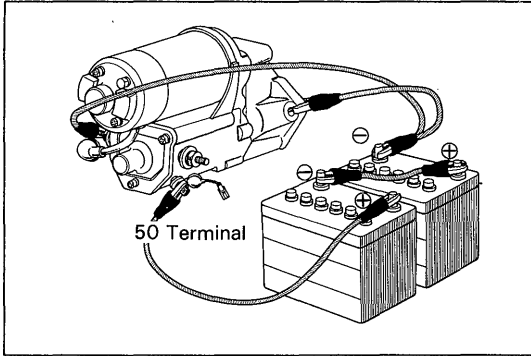

2. Test pull-in coil.
Connect the magnetic switch to the battery as shown in the figure. The pinion should jump out.

Negative side
Battery (-) → Starter housing and C terminal

Positive side
Battery (+) → 50 terminal

Fig. 8-25

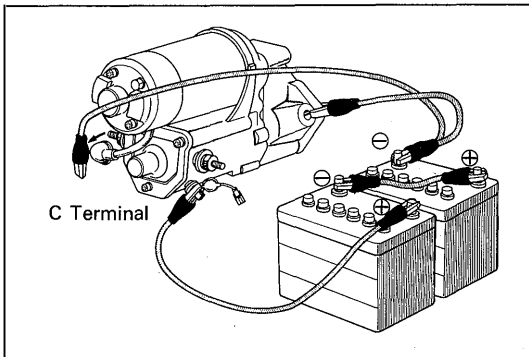

3. Test hold-in coil.
With the same connections as in the "Test pull-in coil", disconnect terminal C. At this time, the pinion should remain in protruding out condition.

Fig. 8-26

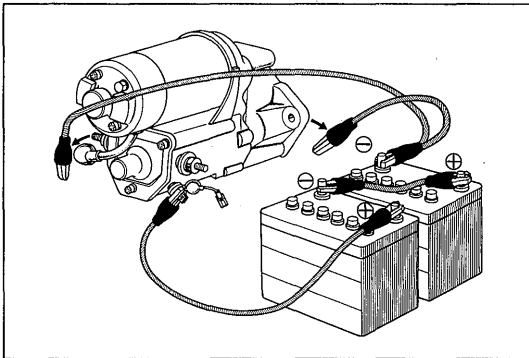

4. Check pinion return.
When disconnecting the cable from the starter housing, the protruding pinion should return quickly.

DISASSEMBLY

Disassemble the parts in the numerical order shown in the figure.

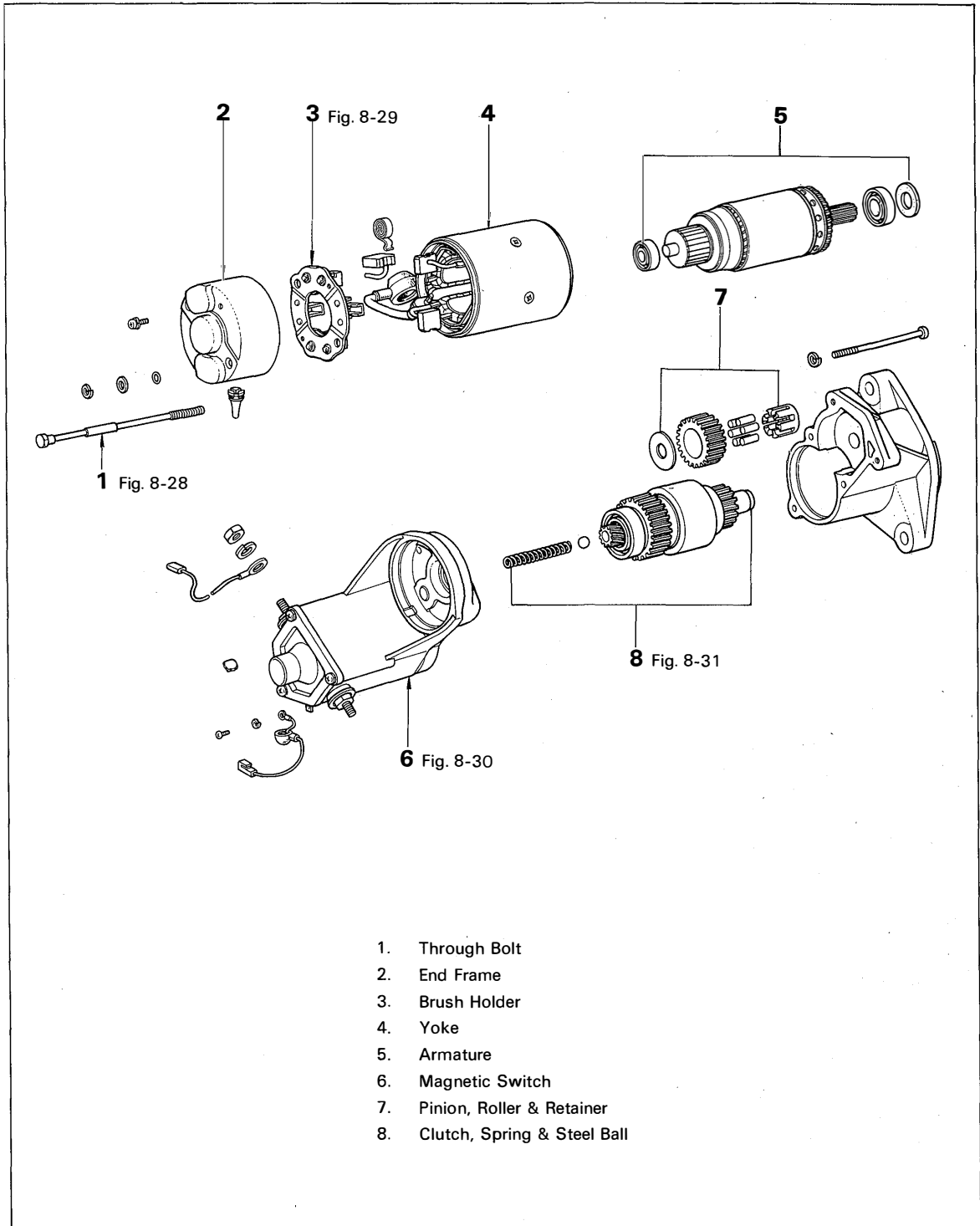
Fig. 8-27

1. Through Bolt
2. End Frame
3. Brush Holder
4. Yoke
5. Armature
6. Magnetic Switch
7. Pinion, Roller & Retainer
8. Clutch, Spring & Steel Ball

Fig. 8-28

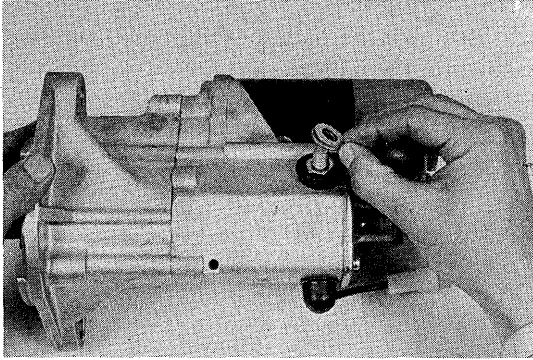

Disconnect the lead wires from the magnetic switch.

Fig. 8-29

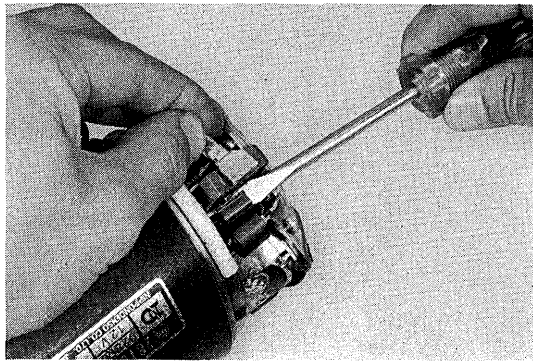

Lift up the brush spring and pull out the brush from the brush holder.

—Note—

Use care not to damage the brush and commutator. Also avoid contact with oil or grease.

Fig. 8-30

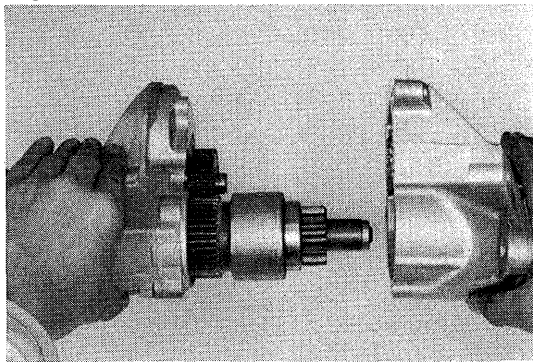

Remove the starter housing together with the idler gear and clutch.

Fig. 8-31

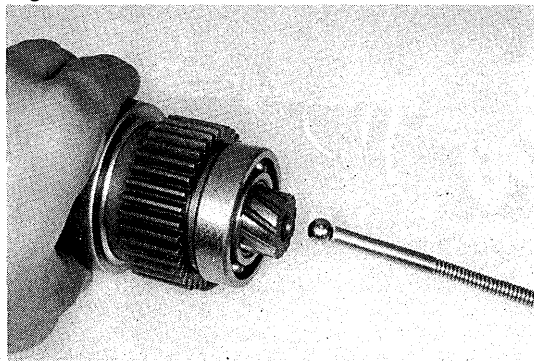

Take the steel ball out of the clutch shaft hole.

Fig. 8-32

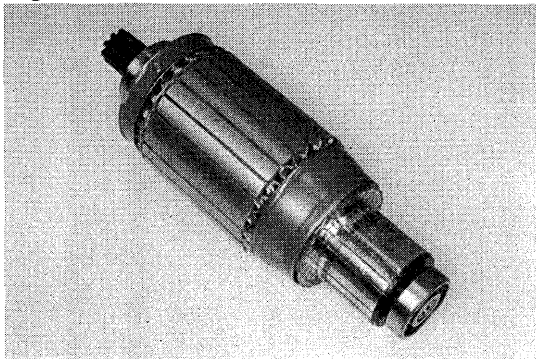
**INSPECTION & REPAIR****Commutator**

Check for the following, and repair or replace, if necessary.

1. Dirty or burnt surface:
Correct with sandpaper.

Fig. 8-33

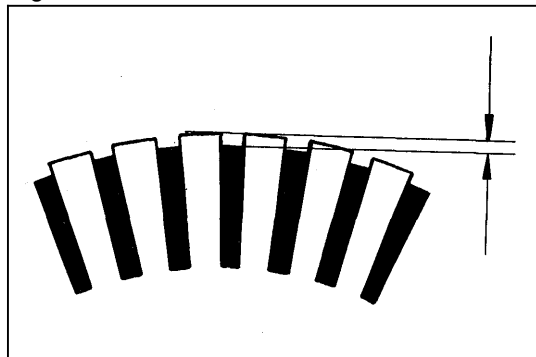

2. Depth of segment mica:

Mica depth:

STD 0.7 – 0.9 mm
(0.028 – 0.035 in.)

Limit 0.2 mm
(0.008 in.)

Fig. 8-34

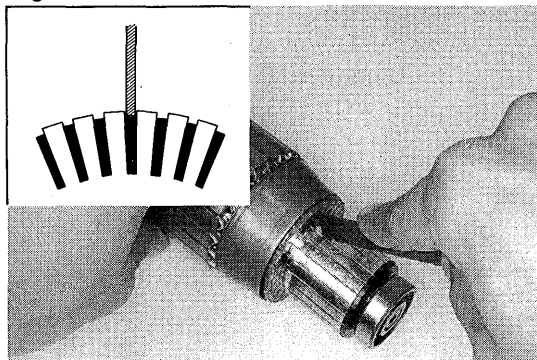

3. Repair the segment mica.
 - (1) If the mica depth is below the limit, correct with a hacksaw blade.

Fig. 8-35

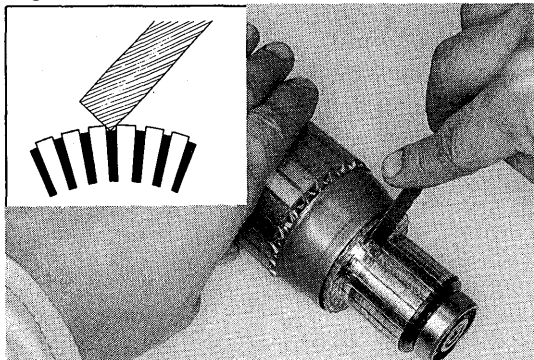

- (2) Smooth out the edges with a hacksaw blade.

Fig. 8-40

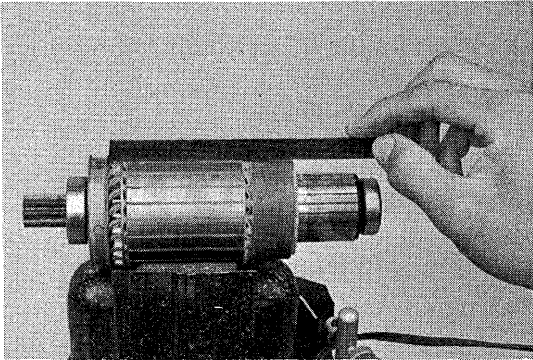

2. Short circuit test:
Place the armature on an armature tester and hold a hacksaw blade against the armature core while turning the armature. If the hacksaw blade is attracted or vibrates, the armature is shorted and must be replaced.

Fig. 8-41

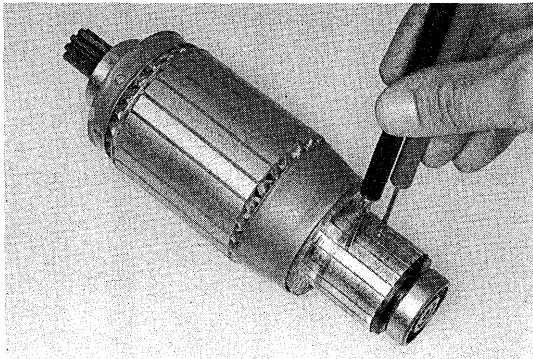

3. Open circuit test:
Using an armature tester or a circuit tester, check for continuity between the segments. If there is no continuity at any test point, there is an open-circuit and the armature must be replaced.

Fig. 8-42

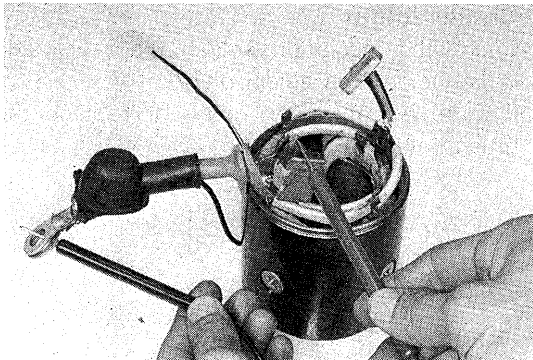

Field Coil

1. Open circuit test:
Check for continuity between the terminal C lead wire and field coil brush. If there is no continuity, there is an open-circuit in the field coil and it should be replaced.

Fig. 8-43

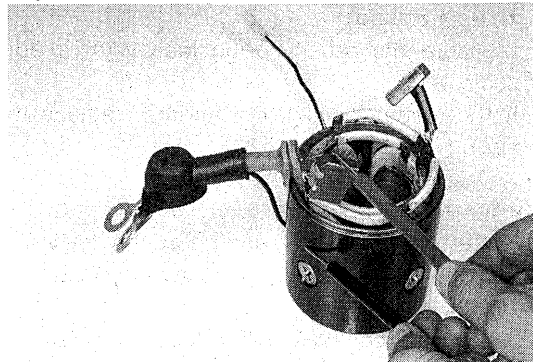

2. Ground test:
Check for continuity between the brush and yoke core. If there is continuity, repair or replace the field coil.

Fig. 8-44

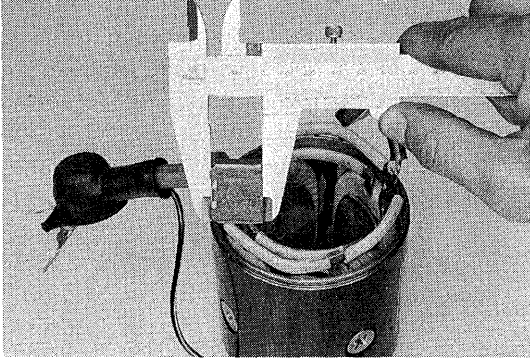

Brushes

1. Measure the brush length and replace if below the limit.

Brush length:

STD	20.5 mm (0.807 in.)
Limit	12 mm (0.47 in.)

Fig. 8-45

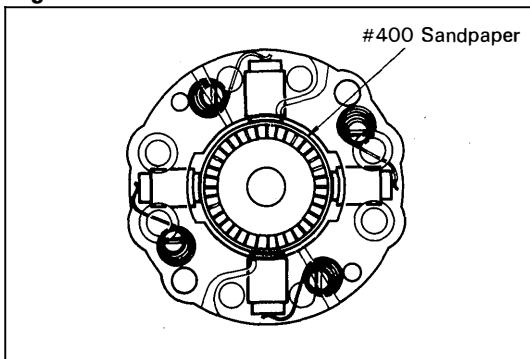

2. Using #400 sandpaper, clean the brushes so they make proper contact with the commutator.

—Note—

Secure the armature gear in a vise or such.

Fig. 8-46

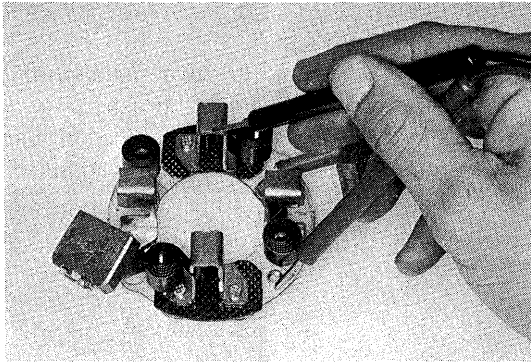

Brush Holder

Check the insulation between the (+) side brush holder and holder plate.

If there is continuity, repair or replace the brush holder.

Fig. 8-47

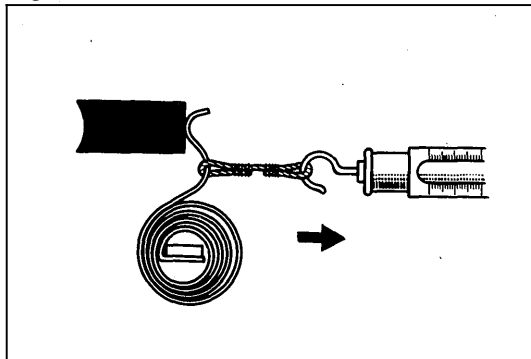

Brush Spring

Measure the brush spring load with a pull scale.

If the reading is below standard, replace the spring.

—Note—

Take the pull-scale reading at the very instant the brush spring separates from the brush.

Tension: 3.2 – 4.0 kg (7 – 9 lb)

Fig. 8-48

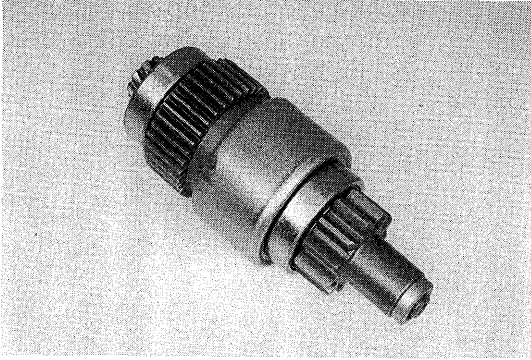
**Clutch & Gears**

1. Check the gear teeth for wear or damage. If damaged, replace, and inspect the fly wheel ring gear for same.

Fig. 8-49

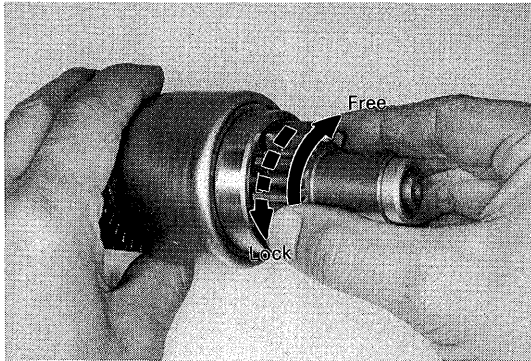

2. Rotate the pinion. It should turn freely in clockwise direction and lock when turned counterclockwise.

Fig. 8-50

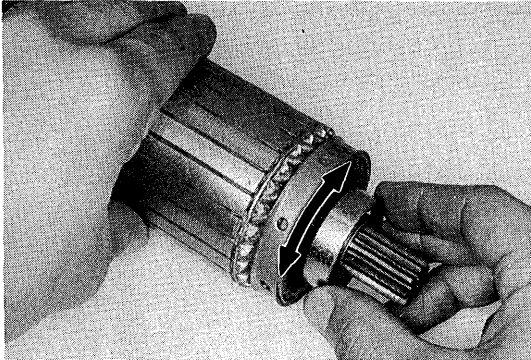
**Bearings**

1. Check for sticking and abnormal noise while turning rapidly.

Fig. 8-51

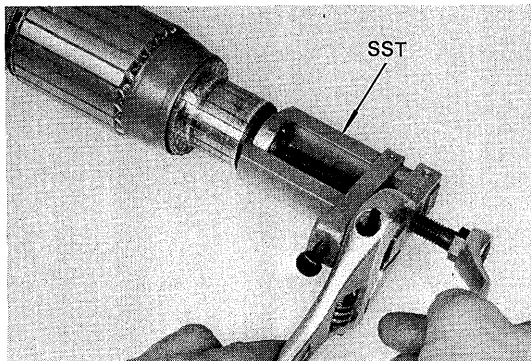

2. Replace the armature bearing if defective.
 - (1) Remove the bearing with SST. SST [09286-46011]

Fig. 8-52

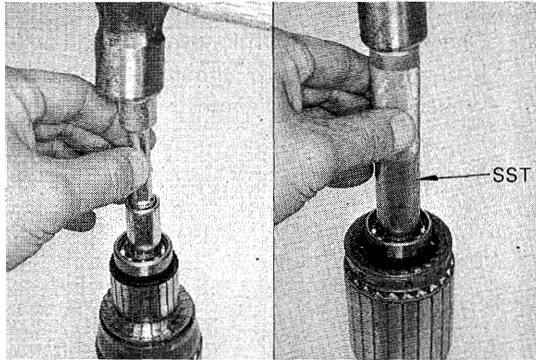

- (2) Replace the front bearing and drive in the rear bearing with SST.
SST [09285-76010]

Fig. 8-53

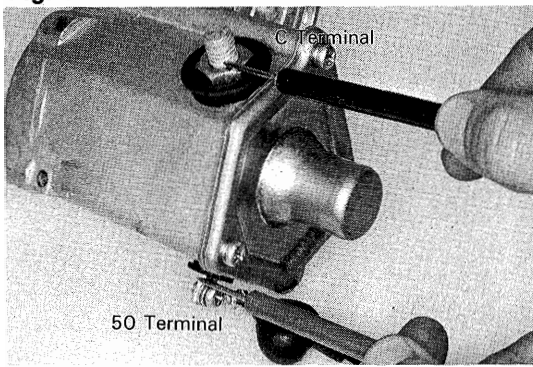

Magnetic Switch

1. Pull-in coil open circuit test:
Check for continuity between the 50 terminal and terminal C.

Fig. 8-54

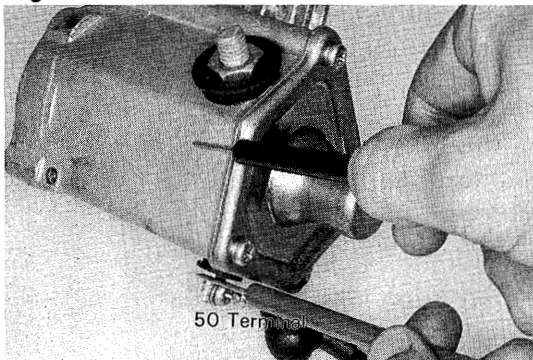

2. Hold-in coil open circuit test:
Check for continuity between the 50 terminal and magnetic switch body.

ASSEMBLY

Assemble the parts in the numerical order shown in the figure.

Fig. 8-55

—Note—

Use high temperature grease to lubricate the bearings and gears indicated by arrows in the figure.

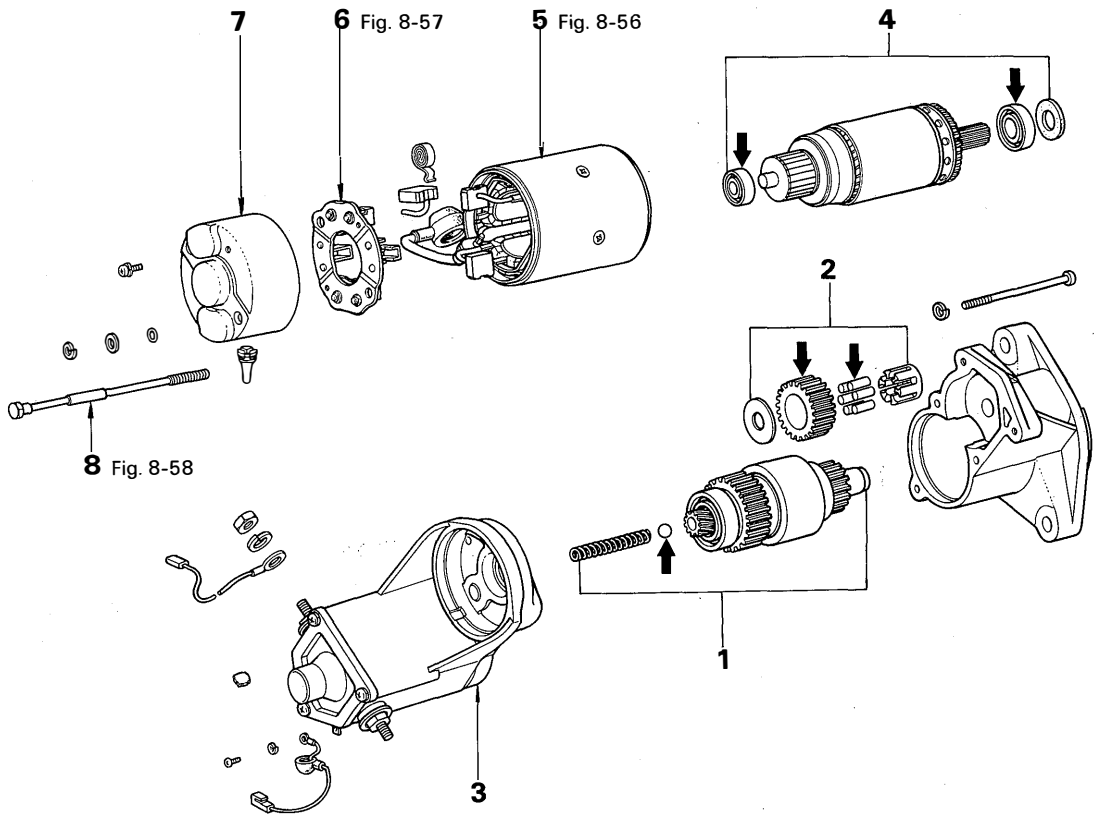

1. Clutch, Spring & Steel Ball
2. Pinion, Roller & Retainer
3. Magnetic Switch
4. Armature
5. Yoke
6. Brush Holder
7. End Frame
8. Through Bolt

Fig. 8-56

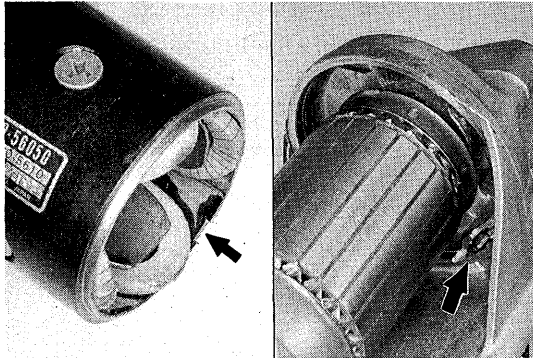

Match the protrusion (small metal plate) of the starter housing with the cutout of the yoke core.

Fig. 8-57

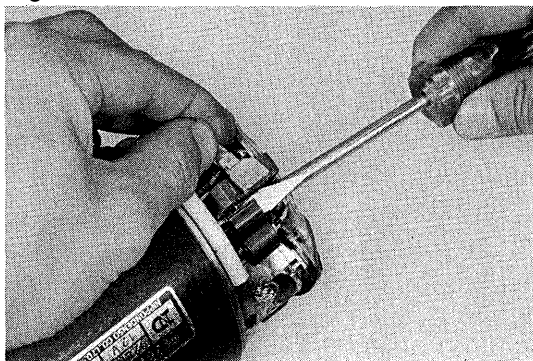

Assemble the brush holder.

–Note–

Use care not to damage or get oil on the brushes and commutator.

Fig. 8-58

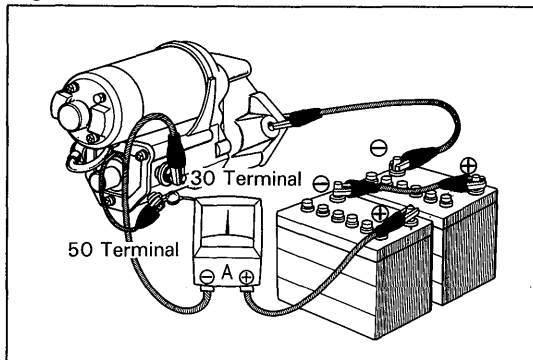

Check performance of the starter after assembling.

Specified current:

12V type	Less than 180A
24V type	Less than 90A

CHARGING SYSTEM

	Page
CHARGING SYSTEM CIRCUITS	9-2
ON-VEHICLE INSPECTION	9-5
ALTERNATOR	9-12
ALTERNATOR REGULATOR	9-26
WARNING LIGHT RELAY	9-29

CHARGING SYSTEM CIRCUITS

TIRRILL REGULATOR TYPE

Fig. 9-1

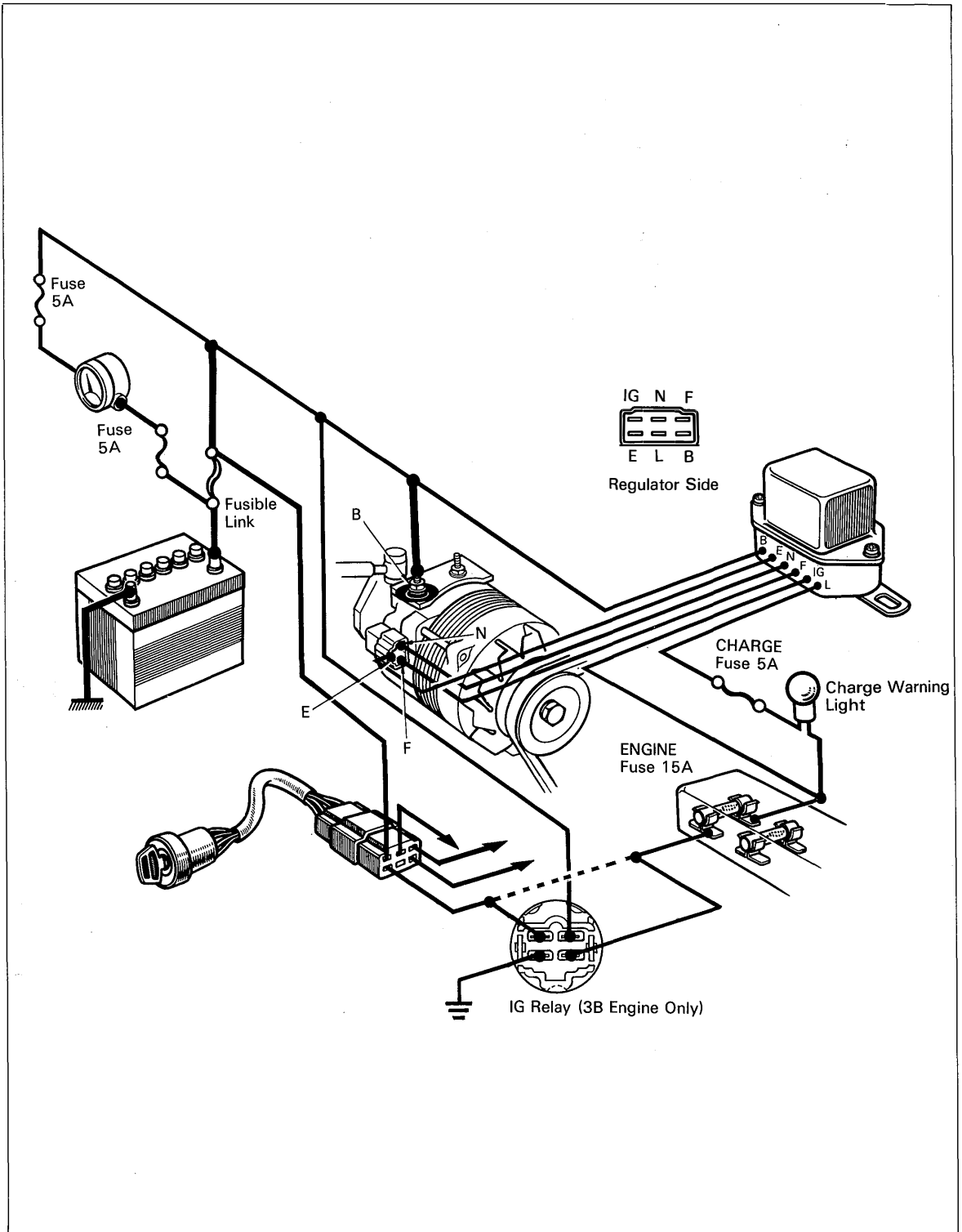

Fig. 9-2

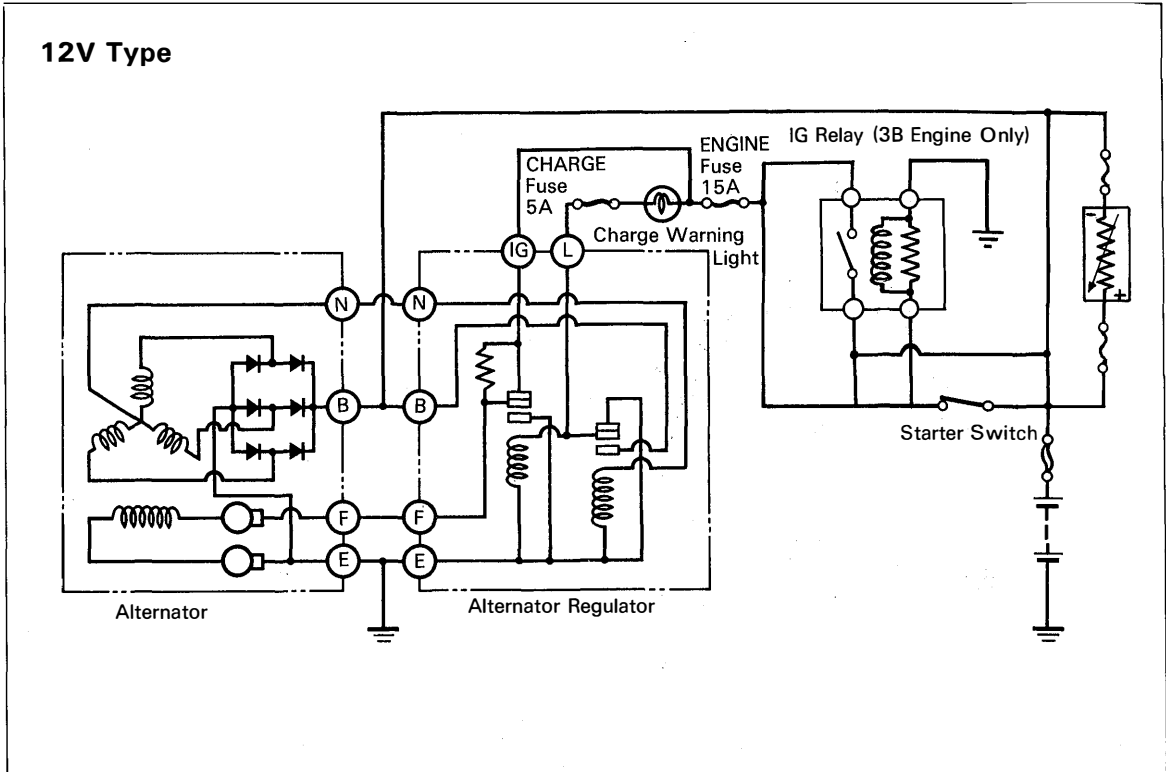

Fig. 9-3

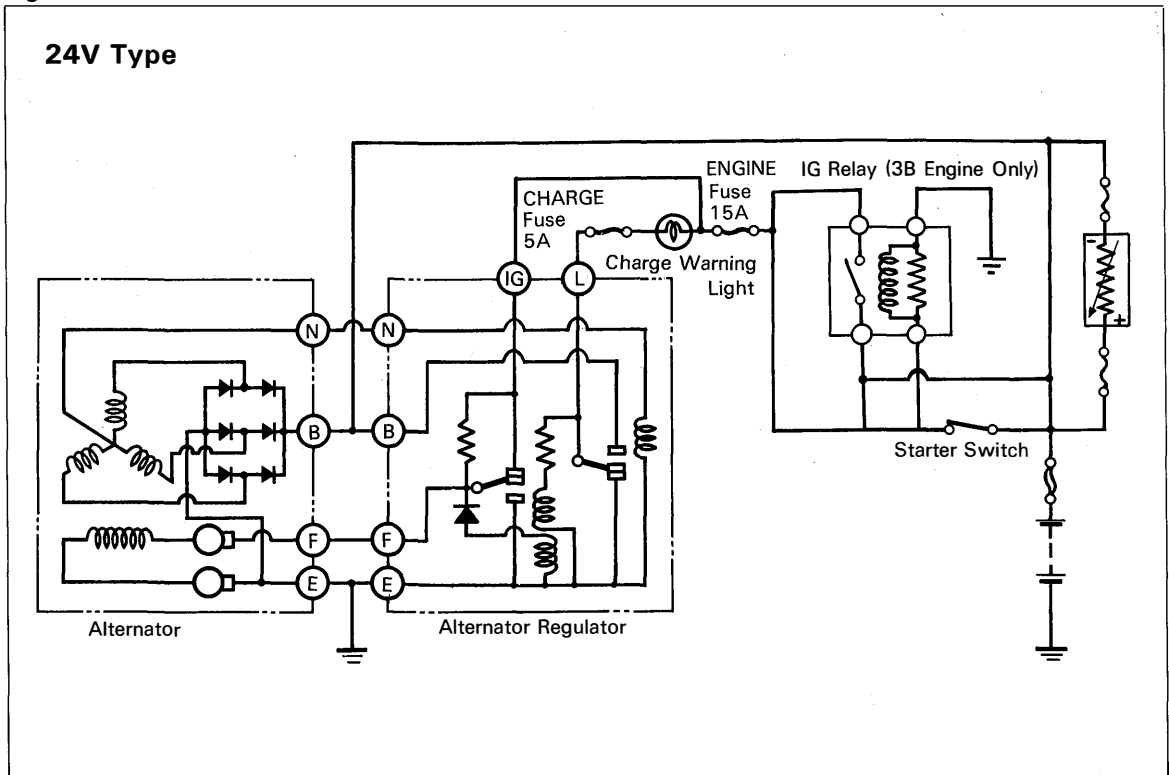

Fig. 9-4

With IC Regulator Type

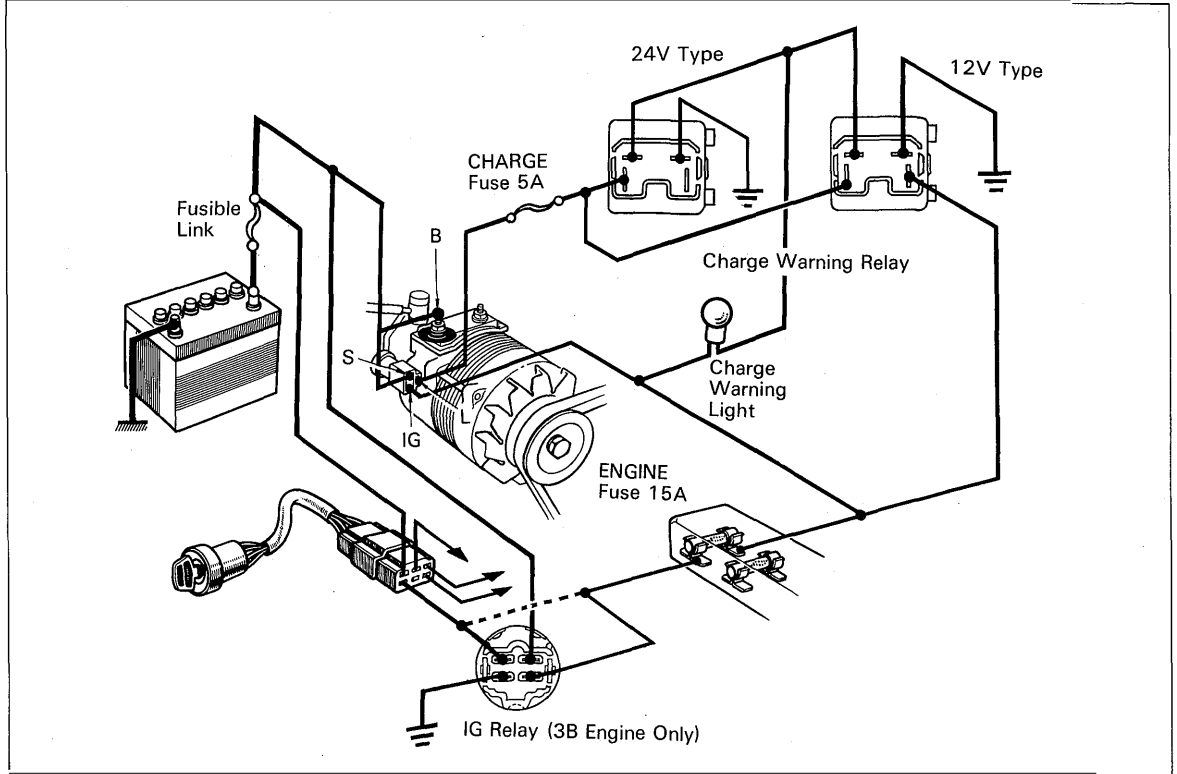

Fig. 9-5

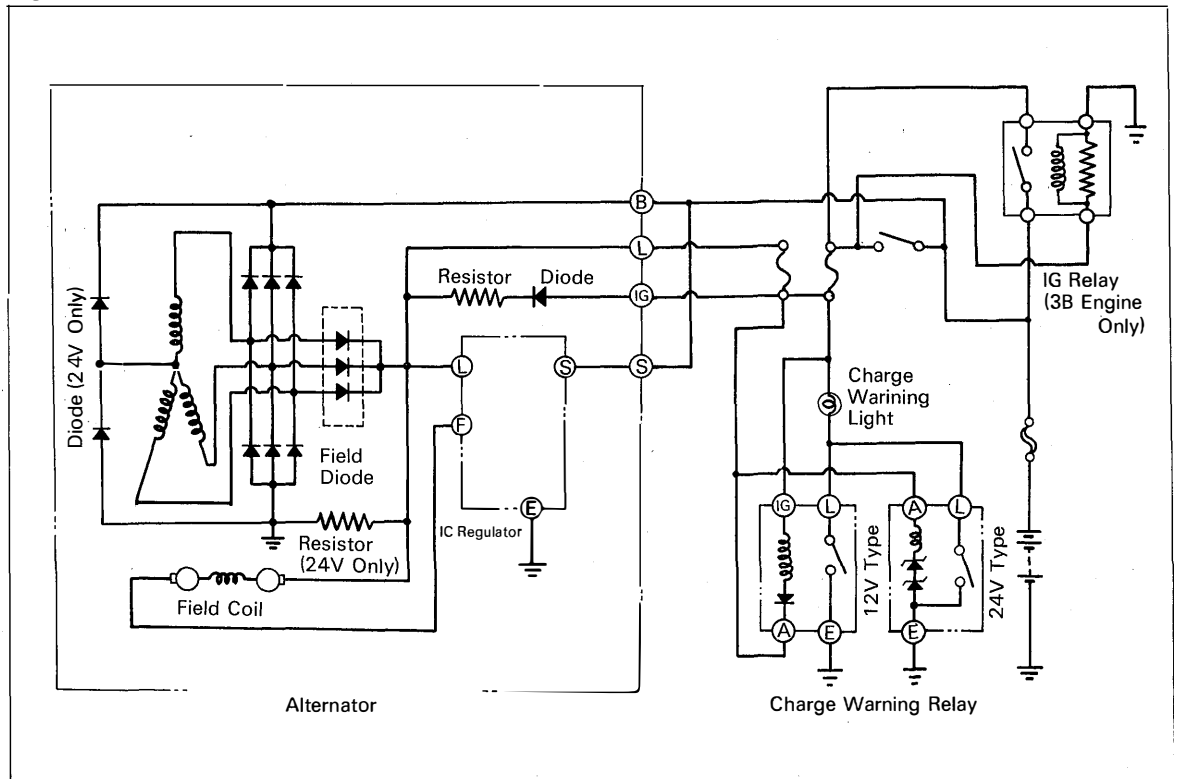

Fig. 9-6

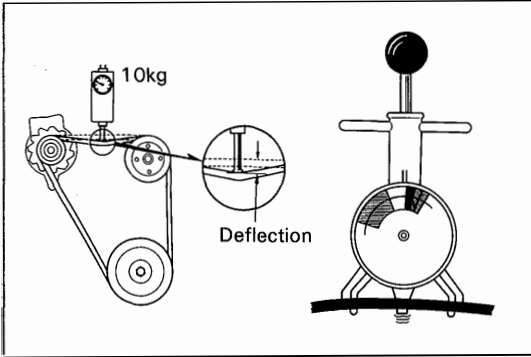

Fig. 9-7

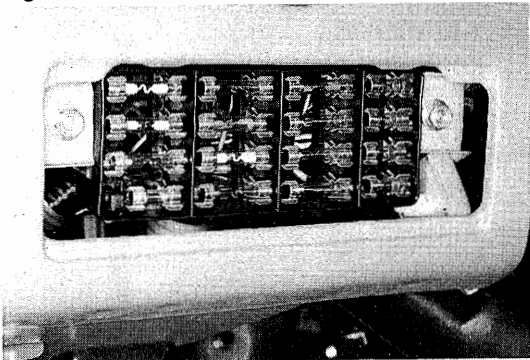

Fig. 9-8

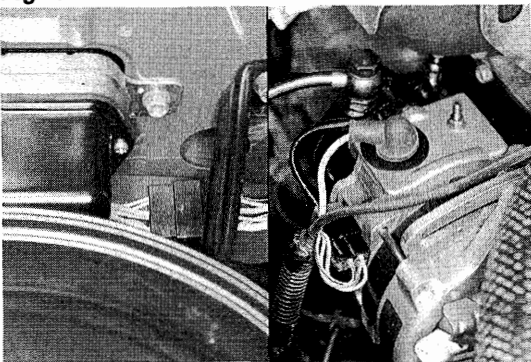
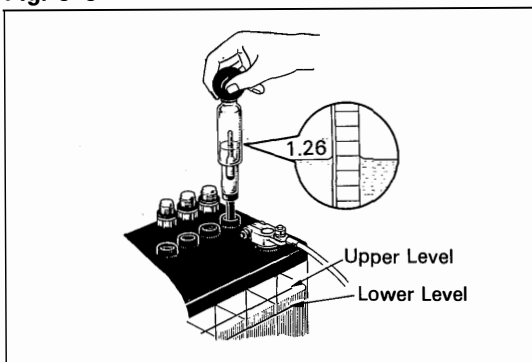

Fig. 9-9



ON-VEHICLE INSPECTION

[Tirrell Regulator Type] CHECK FOLLOWING ITEMS

1. Drive belt tension.

For General

Drive belt tension:

w/o Air cond.

New belt 8 – 12 mm at 10 kg
(0.31 – 0.47 in.)
(22 lb)

Used belt 11 – 14 mm at 10 kg
(0.43 – 0.55 in.)
(22 lb)

w/ Air cond. (BB10)

New belt 10 – 13 mm at 10 kg
(0.39 – 0.51 in.)
(22 lb)

Used belt 12 – 15 mm at 10 kg
(0.47 – 0.59 in.)
(22 lb)

For Canada

Using a borroughs tension gauge, BT-33-73F, adjust as follows:

Driven belt tension:

New belt 120 – 170 lb

Used belt 80 – 120 lb

2. Fuses
3. Installed condition of wiring for alternator and regulator.

4. Battery terminal and fusible link.

Loose

Corroded

Burnt

Specific gravity:

1.25 – 1.27 at 20°C (68°F)

Fig. 9-10

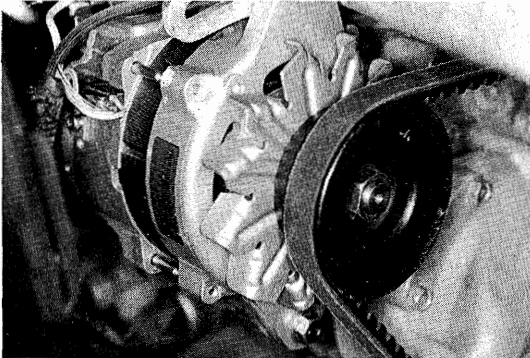

5. Alternator on-vehicle condition.
Abnormal noise from alternator when engine is running.

Fig. 9-11

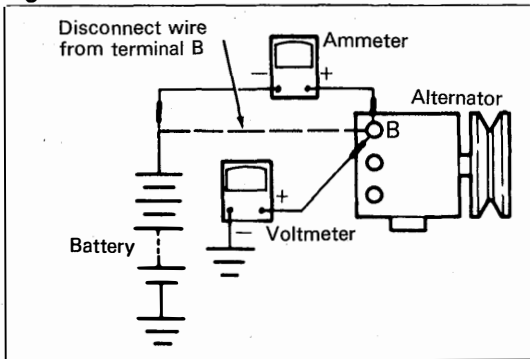

PERFORMANCE TEST BY VOLTMETER & AMMETER

Connect the voltmeter and ammeter as follows.

- Ammeter (+) —————> Alternator terminal B
- Ammeter (-) —————> Wire terminal B
- Voltmeter (+) —————> Alternator terminal B
- Voltmeter (-) —————> Ground

-Note-

Be careful not to cause a short.

Fig. 9-12

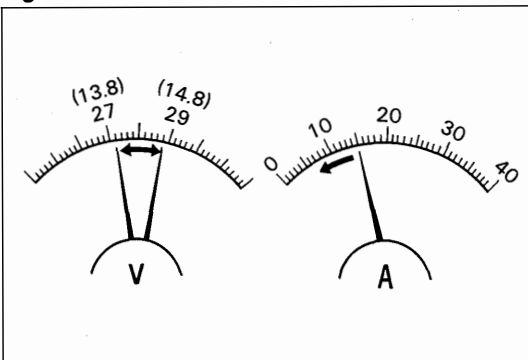

No-load Performance Test

Check the current and voltage.

Voltage:

12V Type 13.8 – 14.8V

24V Type 27 – 29V

Current: Less than 15A

Engine speed: Idling to 2,000 rpm

Fig. 9-13

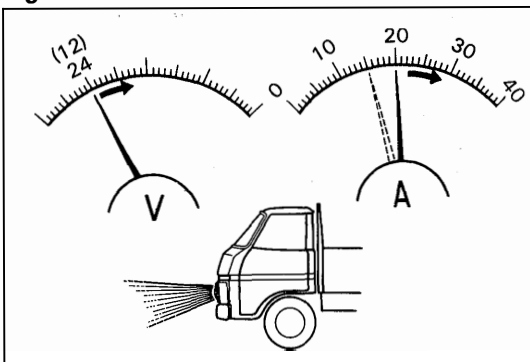

Load Performance Test

1. Run engine at 2,000 rpm.
2. Turn on headlights and all accessories.

Voltage:

12V Type 13.8 – 14.8V

24V Type 27 – 29V

Current:

24V, 20A Type

More than 15A

Others

More than 20A

Fig. 9-14

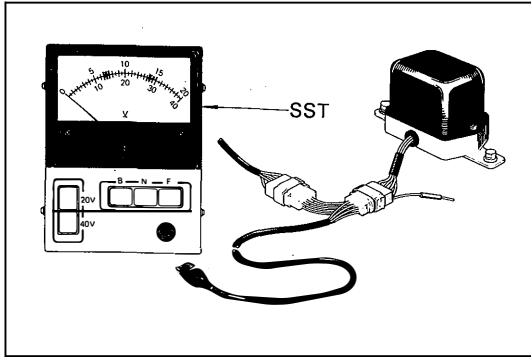

PERFORMANCE TEST WITH SST (ALTERNATOR CHECKER)

Disconnect the alternator regulator connector and connect SST.

SST [09081-00011]

- 12V Type alternator**
Push 20V switch.
- 24V Type alternator**
Push 40V switch.

Fig. 9-15

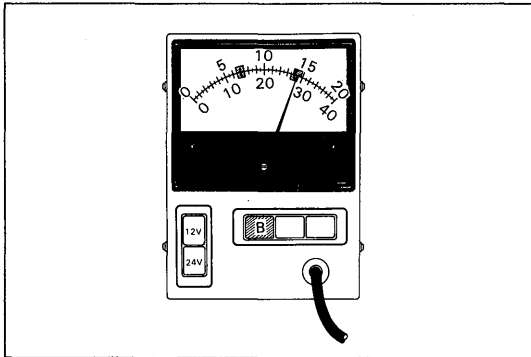

1. Check terminal B voltage.

Push B switch.

Raise engine speed from idling to 2,300 rpm.

Voltage:

STD 12V Type 13.8 – 14.8V

24V Type 27 – 29V

If not within standard, probable cause is the alternator regulator.

Fig. 9-16

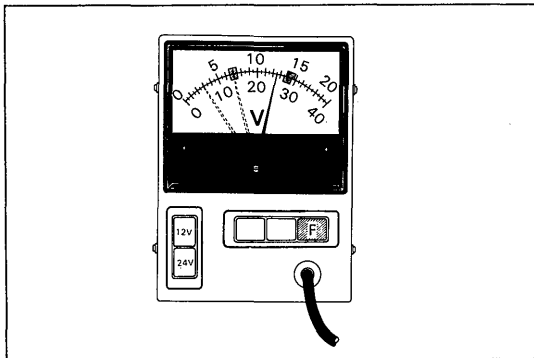

2. Check terminal F voltage.

Push F switch.

Raise engine speed from idling to 2,000 rpm. The checker reading should gradually decrease to 3V.

If no decrease, probable cause is alternator regulator.

Fig. 9-17

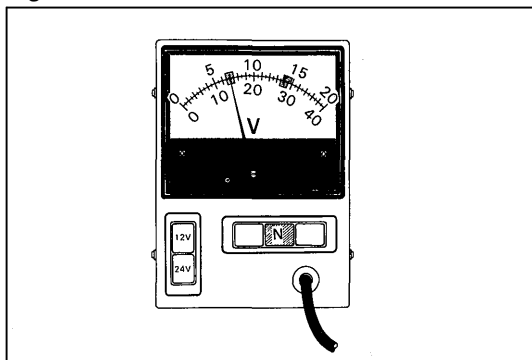

3. Check terminal N voltage.

Push N switch.

Maintain engine speed at approximately 1,500 rpm. The pointer should be at about half of the terminal B voltage.

Voltage:

STD 12V Type 6.9 – 7.4 V

24V Type 13.5 – 14.5 V

If the voltage is higher, the cause is the (+) rectifier.

If the voltage is lower, the cause is the (-) rectifier.

Fig. 9-18

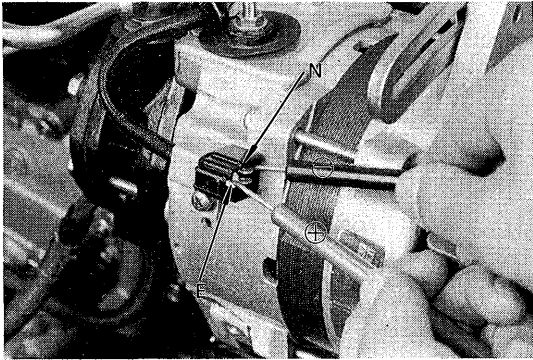
**ALTERNATOR INSPECTION**

1. Negative side rectifier short test
Connect an ohmmeter \ominus lead to terminal N and the \oplus lead to terminal E.
The meter should indicate infinity.

Fig. 9-19

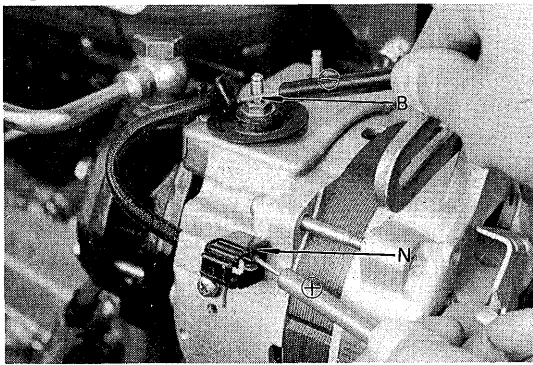

2. Positive side rectifier short test
Connect an ohmmeter \ominus lead to terminal B and the \oplus lead to terminal N.
The meter should indicate infinity.

Fig. 9-20

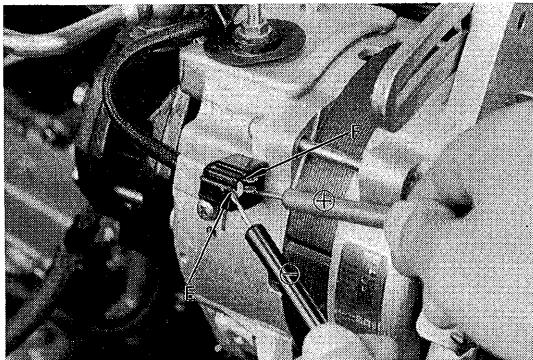

3. Check the rotor coil resistance.

Resistance:**12V Type 2.8 – 3.0 Ω** **24V Type 19.0 Ω**

Fig. 9-21

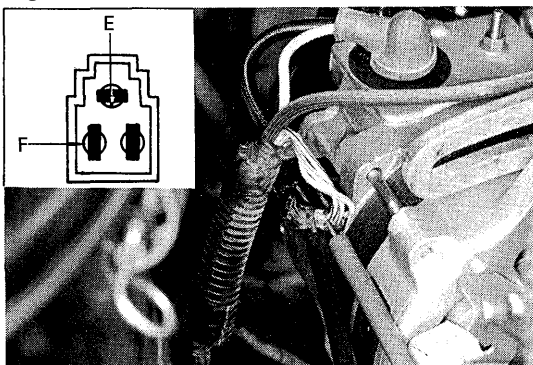

4. Turn the starter switch to ON position, and check to see if there is battery voltage at terminal F.
If not, check the ENGINE fuse.

Fig. 9-22

SEE
CHARGING SYSTEM
ON-VEHICLE INSPECTION
Fig. 9-6 to 9-10

[With IC Regulator Type]

CHECK FOLLOWING ITEMS

1. Drive belt tension
2. Fuses
3. Installed condition of wiring for alternator
4. Battery terminal and fusible link

Fig. 9-23

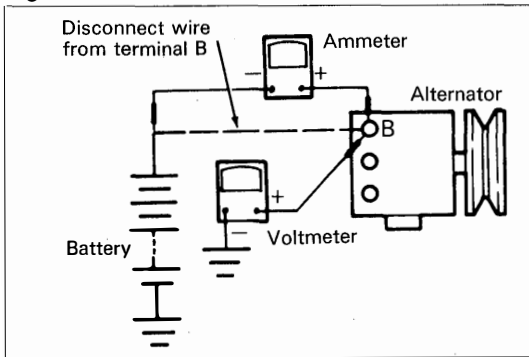

PERFORMANCE TEST

Connect the voltmeter and ammeter as follows.

- Ammeter (+) —————> Alternator terminal B
- Ammeter (-) —————> Wire terminal B
- Voltmeter (+) —————> Alternator terminal B
- Voltmeter (-) —————> Ground

-Note-

Be careful not cause a short.

Fig. 9-24

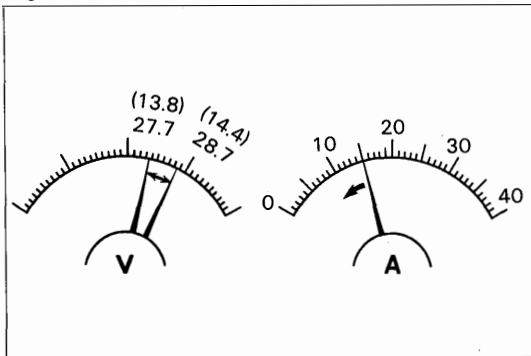

No-load Performance Test

Check the current and voltage.

Voltage:

12V Type 13.8 – 14.4V

24V Type 27.7 – 28.7V

Current: Less than 15A

Engine speed: Idling to 2,000 rpm

Fig. 9-25

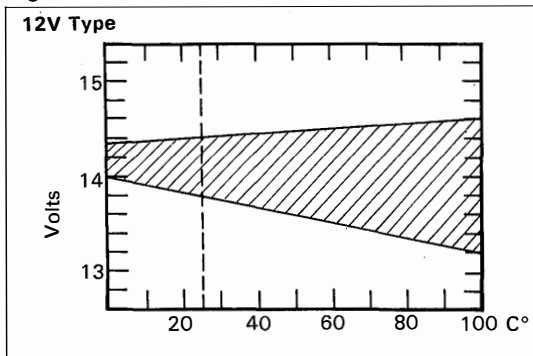

-Note-

If the temperature is not 25°C (77°F), find the voltage limits in the chart for the correct temperature.

Fig. 9-26

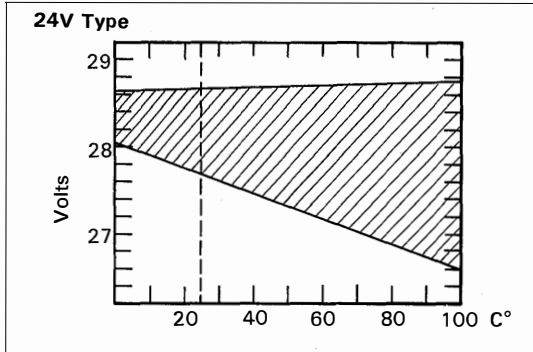

—Note—

If the temperature is not 25°C (77°F), find the voltage limits in the chart for the correct temperature.

Fig. 9-27

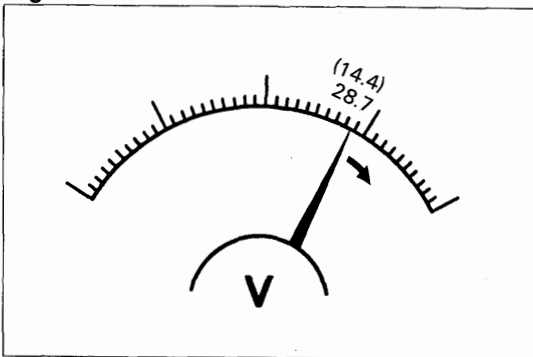

If the voltage reading is greater than 14.4 (12V Type) or 28.7V (24V Type), replace the IC regulator.

Fig. 9-28

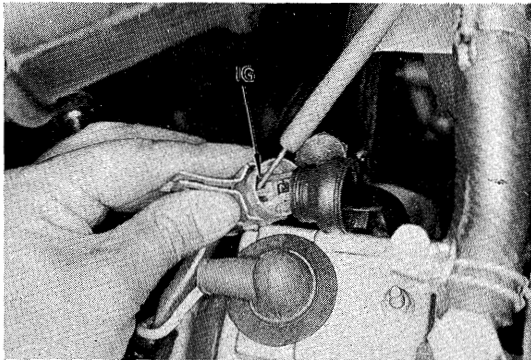

If the voltage reading is less than 13.8 (12V Type) or 27.7V (24V Type), check the alternator and IC regulator.

1. Turn the starter switch to ON position.
2. Check the voltage reading at the alternator terminal IG.
If no voltage, check the engine fuse and/or starter switch.

Fig. 9-29

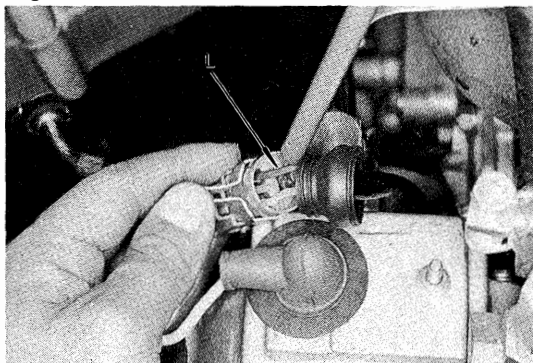

3. Check the voltage reading at the alternator terminal L.
If the voltage reading is less than 4V, check the alternator.

Fig. 9-30

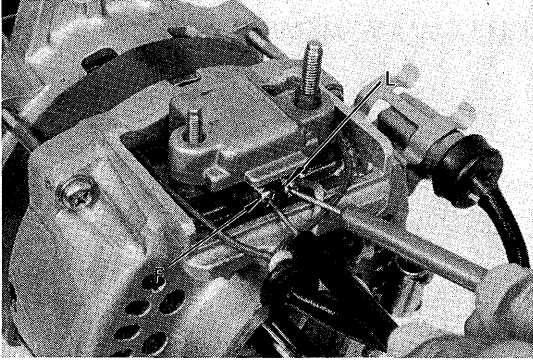

4. If the voltage is same as battery voltage, disassemble the alternator and check the continuity between terminals L and F.

No continuity—Check the alternator Continuity

(12V Type Approx: 2.8 – 3.0Ω)
(24V Type Approx: 19.0Ω)

– Replace the IC regulator

Fig. 9-31

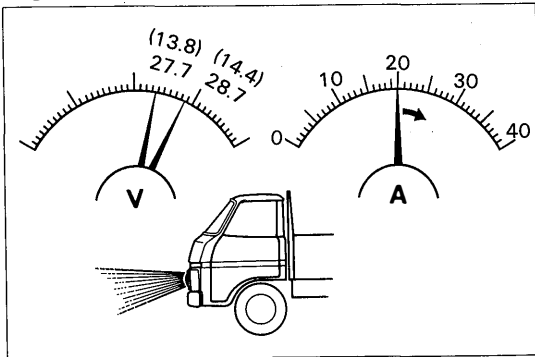

Load Performance Test

1. Run engine at 2,000 rpm.
2. Turn on headlights and all accessories.

Voltage:

12V Type 13.8 – 14.4V

24V Type 27.7 – 28.7V

Current: More than 20A

ALTERNATOR CUTAWAY VIEW

Fig. 9-32

Tirril Regulator Type

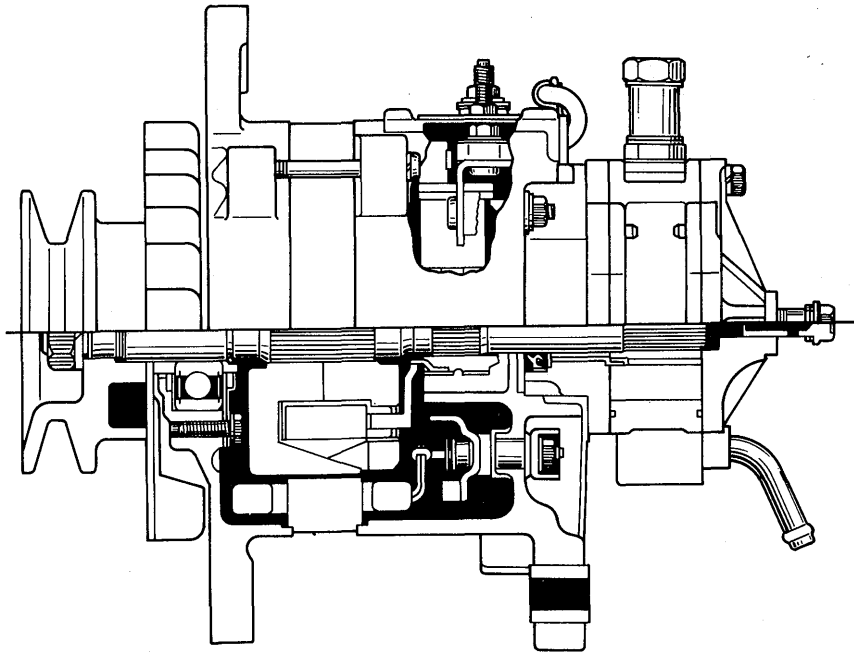

With IC Regulator Type

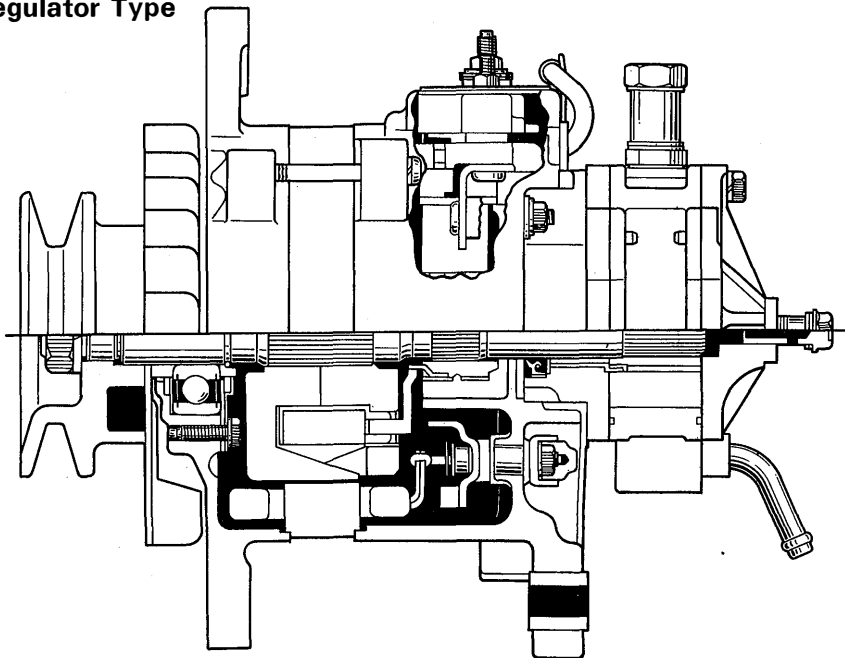

DISASSEMBLY

Disassemble the parts in the numerical order shown in the figure.

Fig. 9-33

For Tirrill Regulator Type

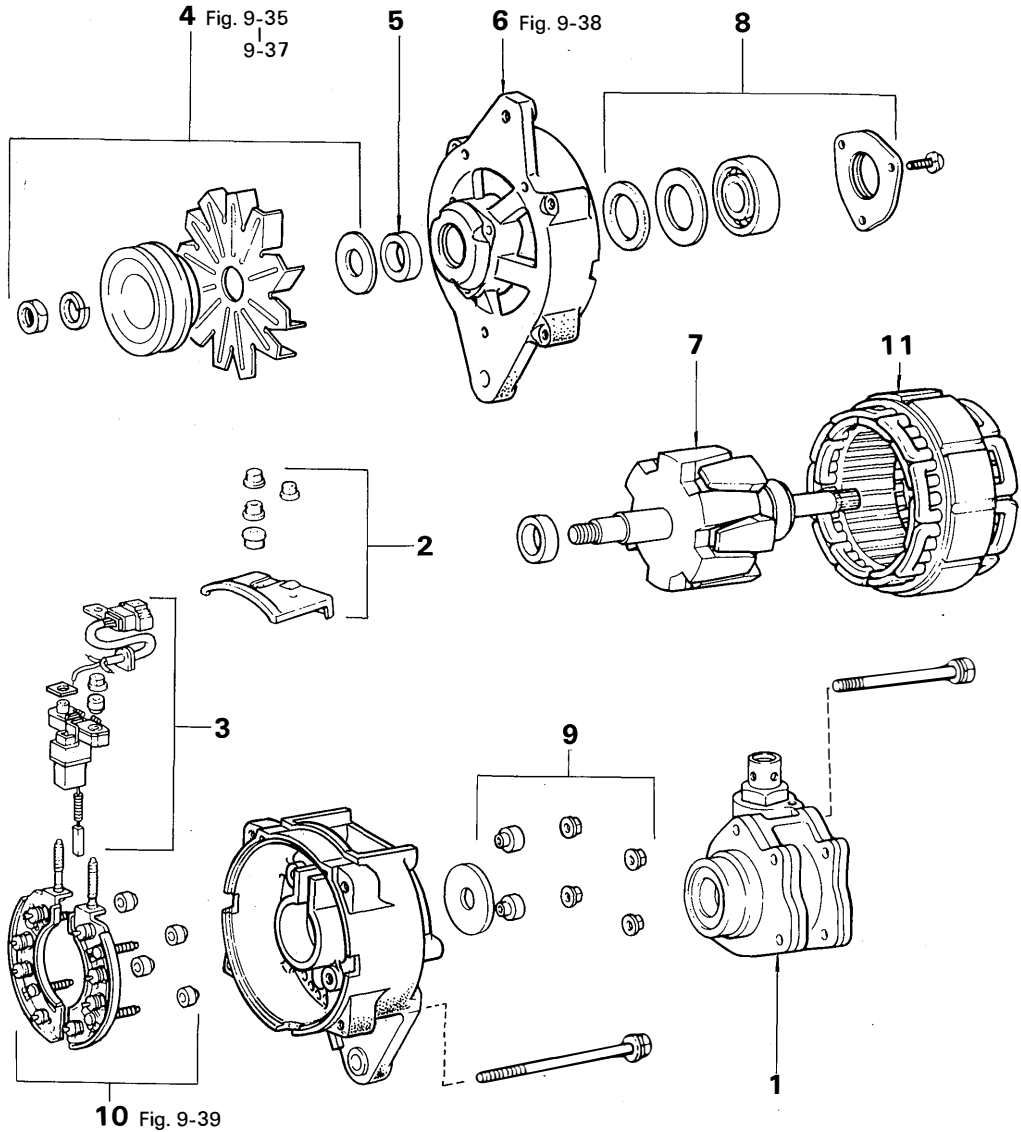

- | | |
|----------------------------|----------------------------------|
| 1. Vacuum Pump | 7. Rotor |
| 2. Brush Cover | 8. Front Bearing |
| 3. Brush Holder & Terminal | 9. Insulator & Nut |
| 4. Pulley & Fan | 10. Rectifier Holder & Insulator |
| 5. Collar | 11. Stator Coil |
| 6. Drive End Frame | |

Disassemble the parts in the numerical order shown in the figure.

Fig. 9-34

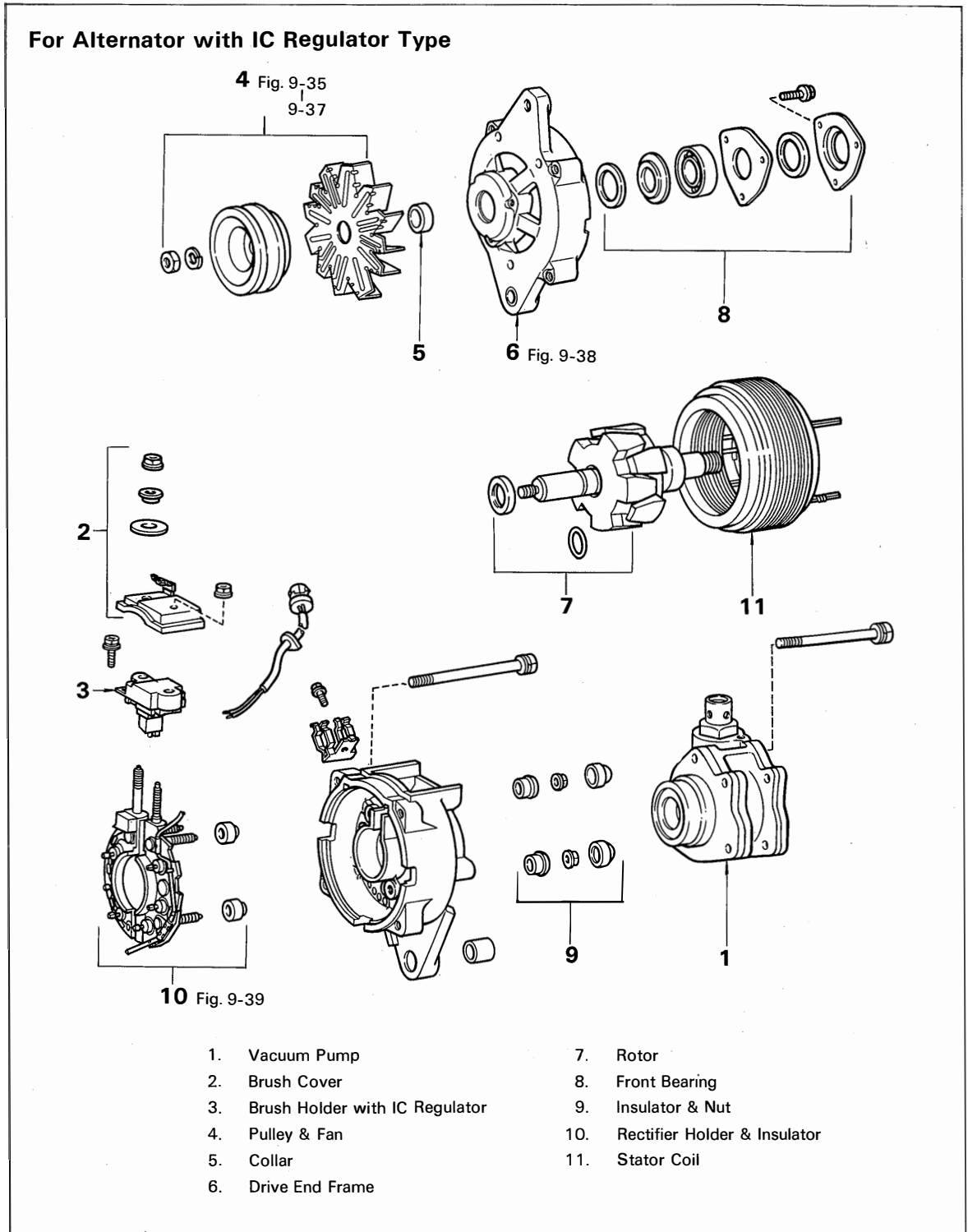
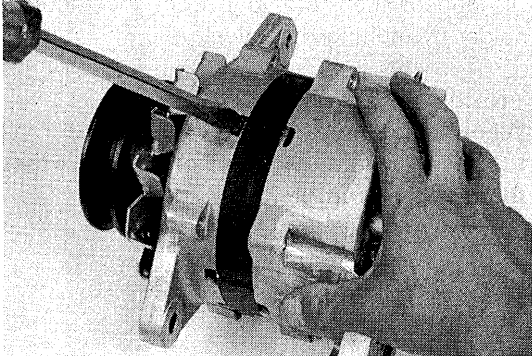

Fig. 9-35



Pry off the drive end frame from the stator.

–Note–

Do not damage the coil wires.

Fig. 9-36

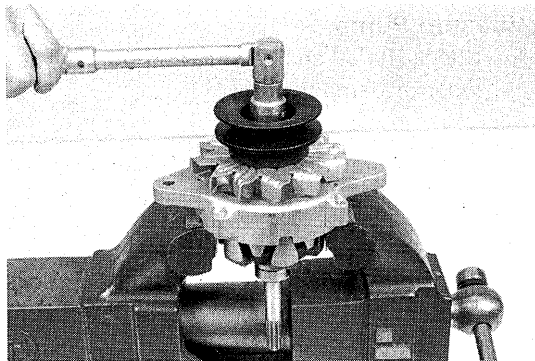

Using a soft jaw vise, loosen the pulley nut.

Fig. 9-37

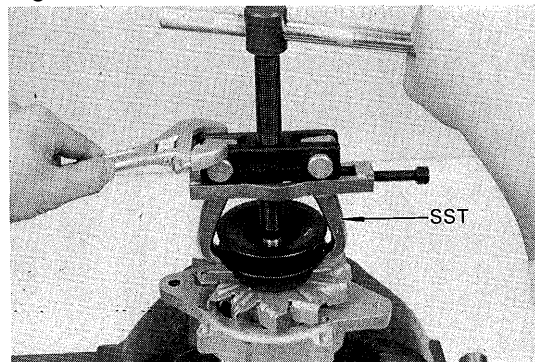

Remove the pulley with SST.
SST [09950-20014]

Fig. 9-38

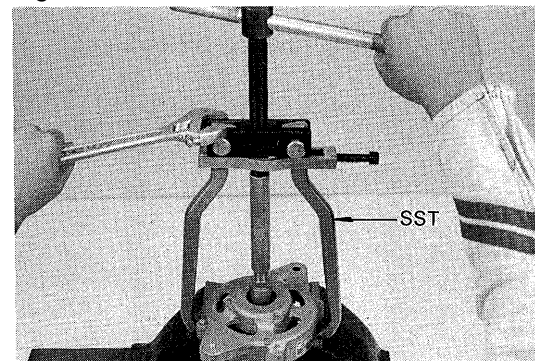

Remove the drive end frame with SST.
SST [09950-20014]

Fig. 9-39

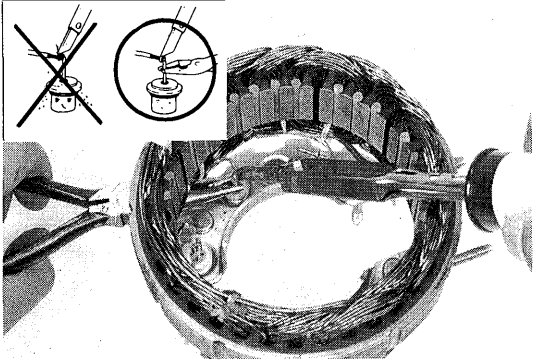

Disconnect the stator coil from the rectifier holder by melting the solder.

—Note—

When unsoldering the leads, hold the rectifier lead with a long nose pliers to protect the rectifier from heat.

Fig. 9-40

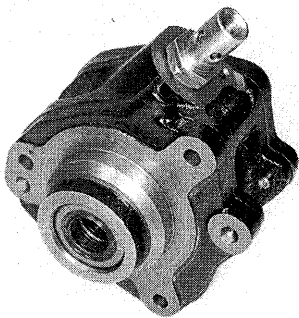

INSPECTION

Vacuum Pump

1. Check the oil seal, spline and bushing for wear or damage.

Fig. 9-41

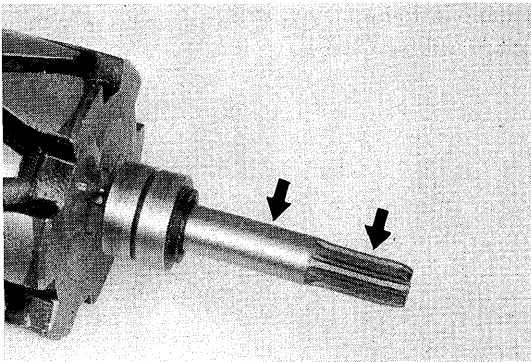

2. Check the journal and spline teeth for wear.

Fig. 9-42

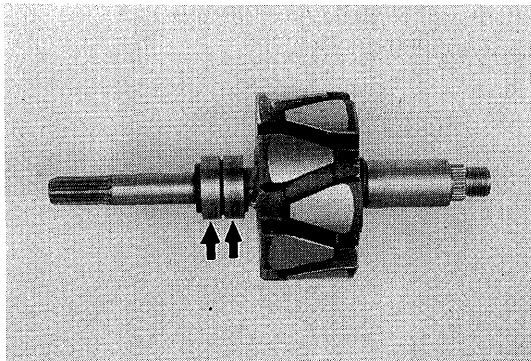

Rotor

1. Check the slip ring for dirt or burns.

Fig. 9-43

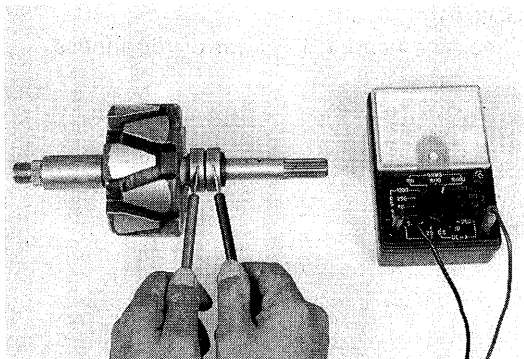

2. Open circuit test
Measure the resistance between both slip rings.

Resistance:12V Type 2.8 – 3.0 Ω 24V Type 19.0 Ω

Fig. 9-44

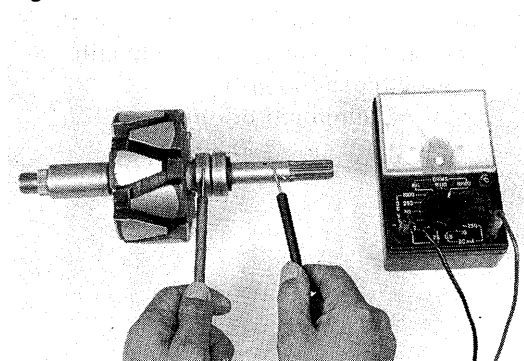

3. Ground test
Check that there is no continuity between the slip ring and rotor.

Fig. 9-45

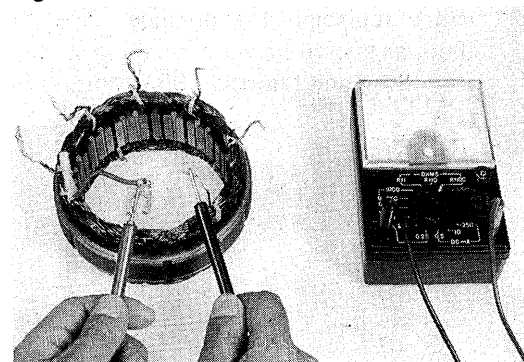
**Stator**

1. Open circuit test
Check that there is continuity between each coil lead.

Fig. 9-46

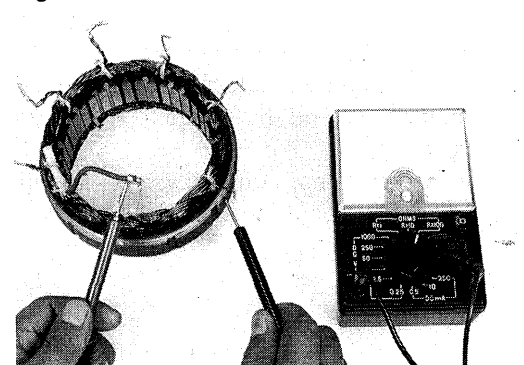

2. Ground test
Check that there is no continuity between each coil lead and stator core.

Fig. 9-47

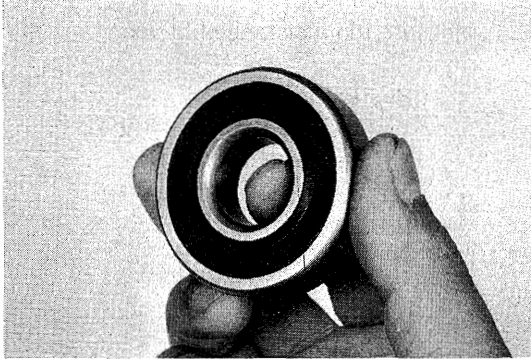

Bearing

Check the bearing for wear or roughness.

Fig. 9-48

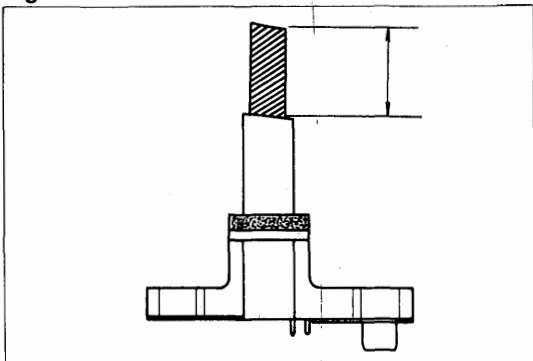

Brush & Brush Holder

1. Measure the exposed brush length.

Exposed length:

Minimum 5.5 mm

(0.217 in.)

Fig. 9-49

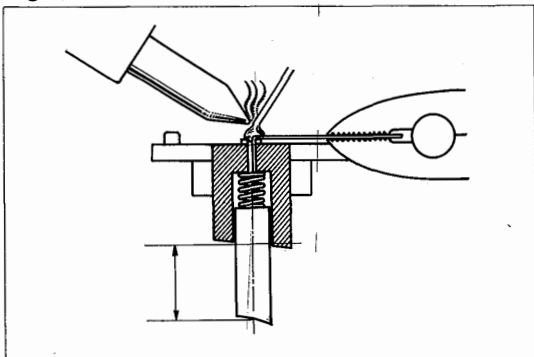

2. When replacing the brushes, assemble them as shown in the figure.

Exposed length: 20.0 mm

(0.787 in.)

Fig. 9-50

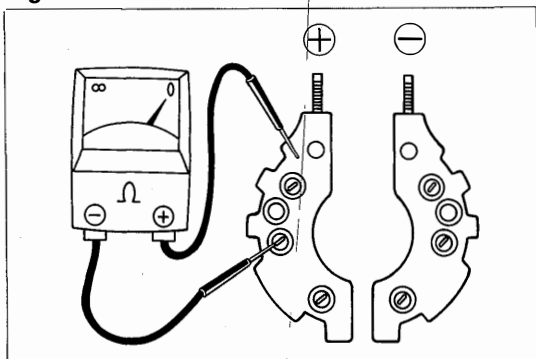

Rectifier

1. Rectifier holder positive side
Connect an ohmmeter \oplus lead to the rectifier holder, and the \ominus lead to the rectifier terminal.

If there is no continuity, the rectifier assembly must be replaced.

Fig. 9-51

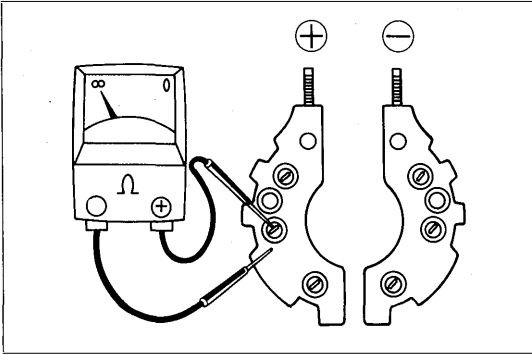

2. Reverse the polarity of the test leads and check again. If there is continuity, the rectifier assembly must be replaced.

Fig. 9-52

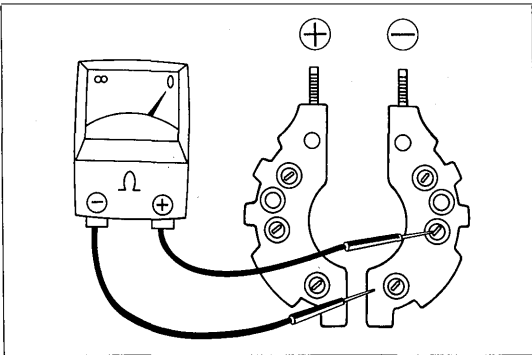

3. Rectifier holder negative side
Connect an ohmmeter ⊕ lead to the rectifier terminal, and the ⊖ lead to the rectifier holder.
If there is no continuity, the rectifier assembly must be replaced.

Fig. 9-53

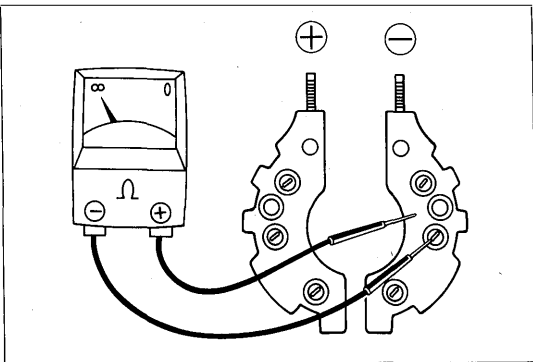

4. Reverse polarity of the test leads and check again. If there is continuity, the rectifier assembly must be replaced.

Fig. 9-54

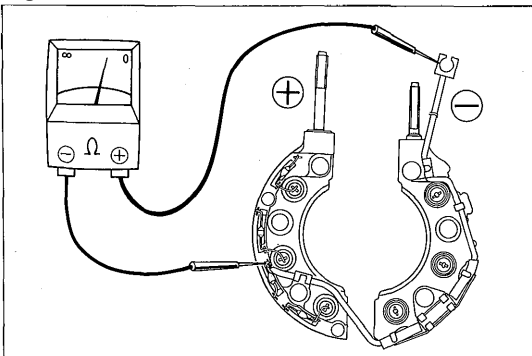

Resistor (for Alternator with IC Regulator)

Measure the resistance with an ohmmeter.

Resistance:

12V Type 19Ω

24V Type 150Ω

Fig. 9-55

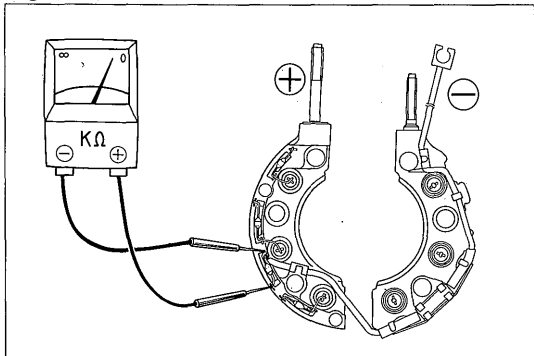

Diode (for Alternator with IC Regulator)

1. Connect an ohmmeter \oplus lead to the resistor side, and the \ominus lead of the meter to the other side of the diode. If there is no continuity, rectifier assembly must be replaced.

Fig. 9-56

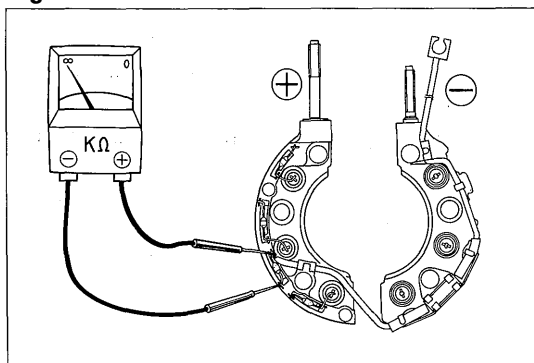

2. Reverse polarity of test leads and check again. If there is continuity, the rectifier assembly must be replaced.

Fig. 9-57

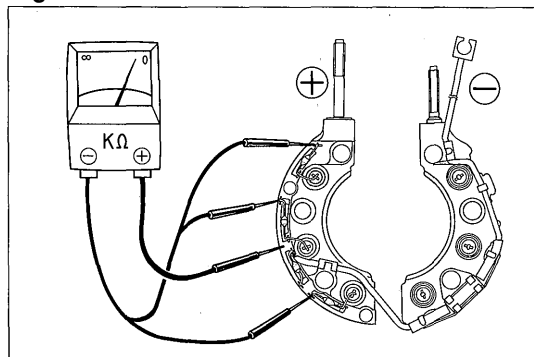

Field Diodes (for Alternator with IC Regulator)

1. Connect an ohmmeter \oplus lead to the rectifier holder, and the \ominus lead of the meter to the field diode terminal. If there is no continuity, rectifier assembly must be replaced.

Fig. 9-58

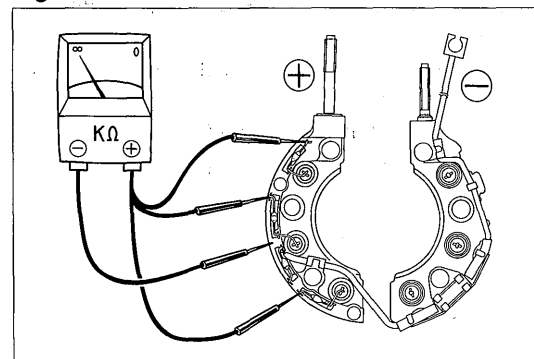

2. Reverse polarity of test leads and check again. If there is continuity, the rectifier assembly must be replaced.

Fig. 9-59

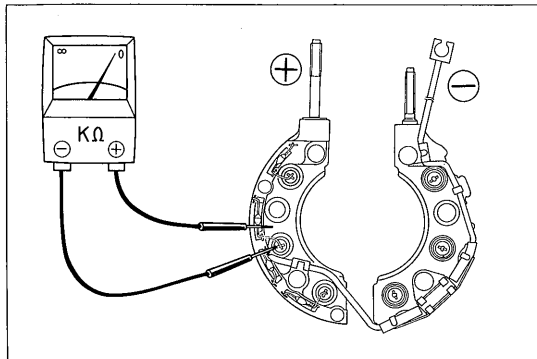

Rectifier (for Alternator with IC Regulator)

1. Rectifier holder positive side
Connect an ohmmeter \oplus lead to the rectifier holder, and the \ominus lead of the meter to the rectifier terminal. If there is no continuity, the rectifier assembly must be replaced.

Fig. 9-60

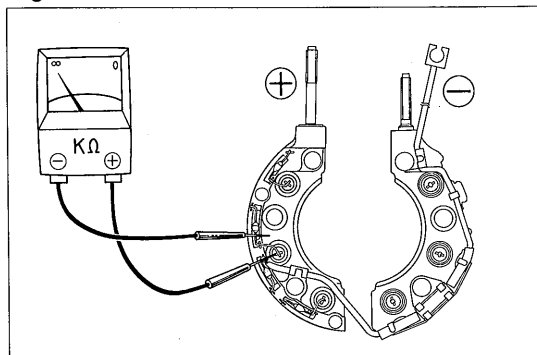

2. Reverse polarity of test leads and check again. If there is continuity, the rectifier assembly must be replaced.

Fig. 9-61

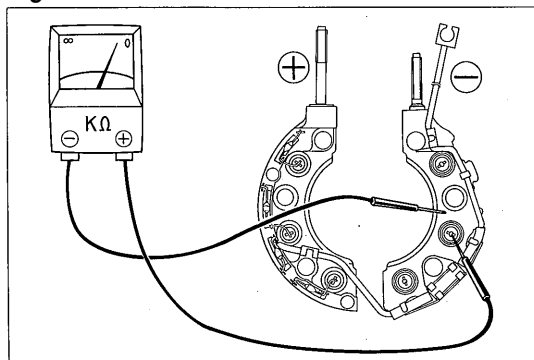

3. Rectifier holder negative side
Connect an ohmmeter \oplus lead to the rectifier terminal, and the \ominus lead of the meter to the rectifier holder. If there is no continuity, the rectifier assembly must be replaced.

Fig. 9-62

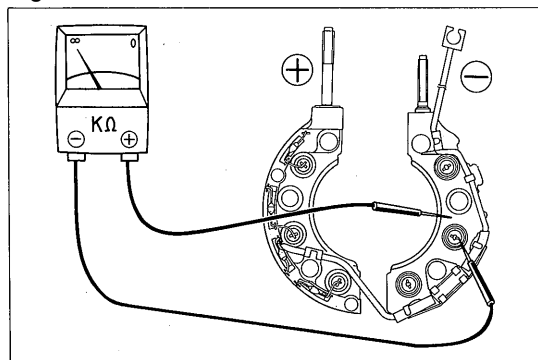

4. Reverse polarity of test leads and check again. If there is continuity, the rectifier assembly must be replaced.

ASSEMBLY

Assemble the parts in the numerical order shown in the figure.

Fig. 9-63

For Tirrill Regulator Type

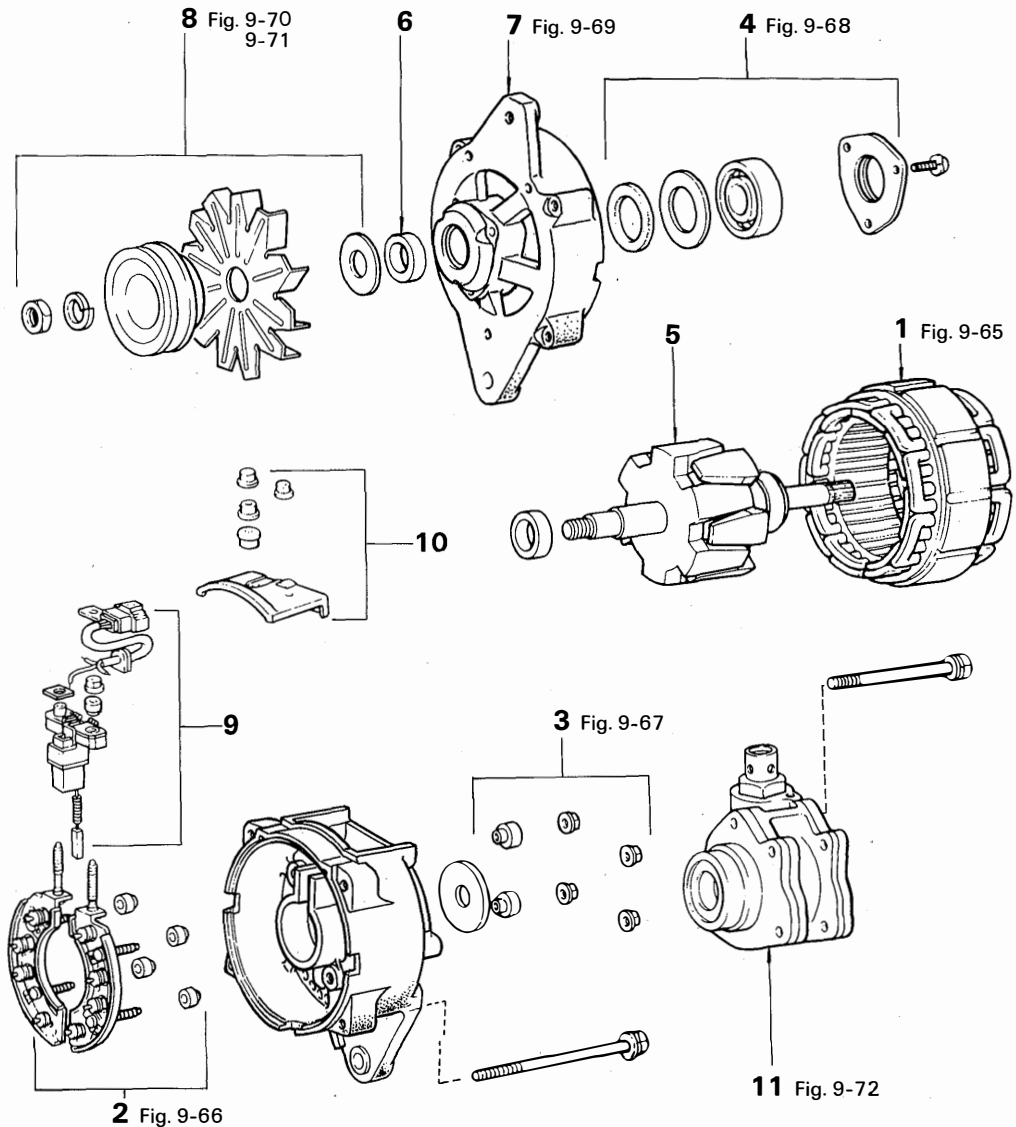

- | | |
|---------------------------------|----------------------------|
| 1. Stator Coil | 7. Drive End Frame |
| 2. Rectifier Holder & Insulator | 8. Pulley & Fan |
| 3. Insulator & Nut | 9. Brush Holder & Terminal |
| 4. Front Bearing | 10. Brush Cover |
| 5. Rotor | 11. Vacuum Pump |
| 6. Collar | |

Assemble the parts in the numerical order shown in the figure.

Fig. 9-64

For Alternator with IC Regulator

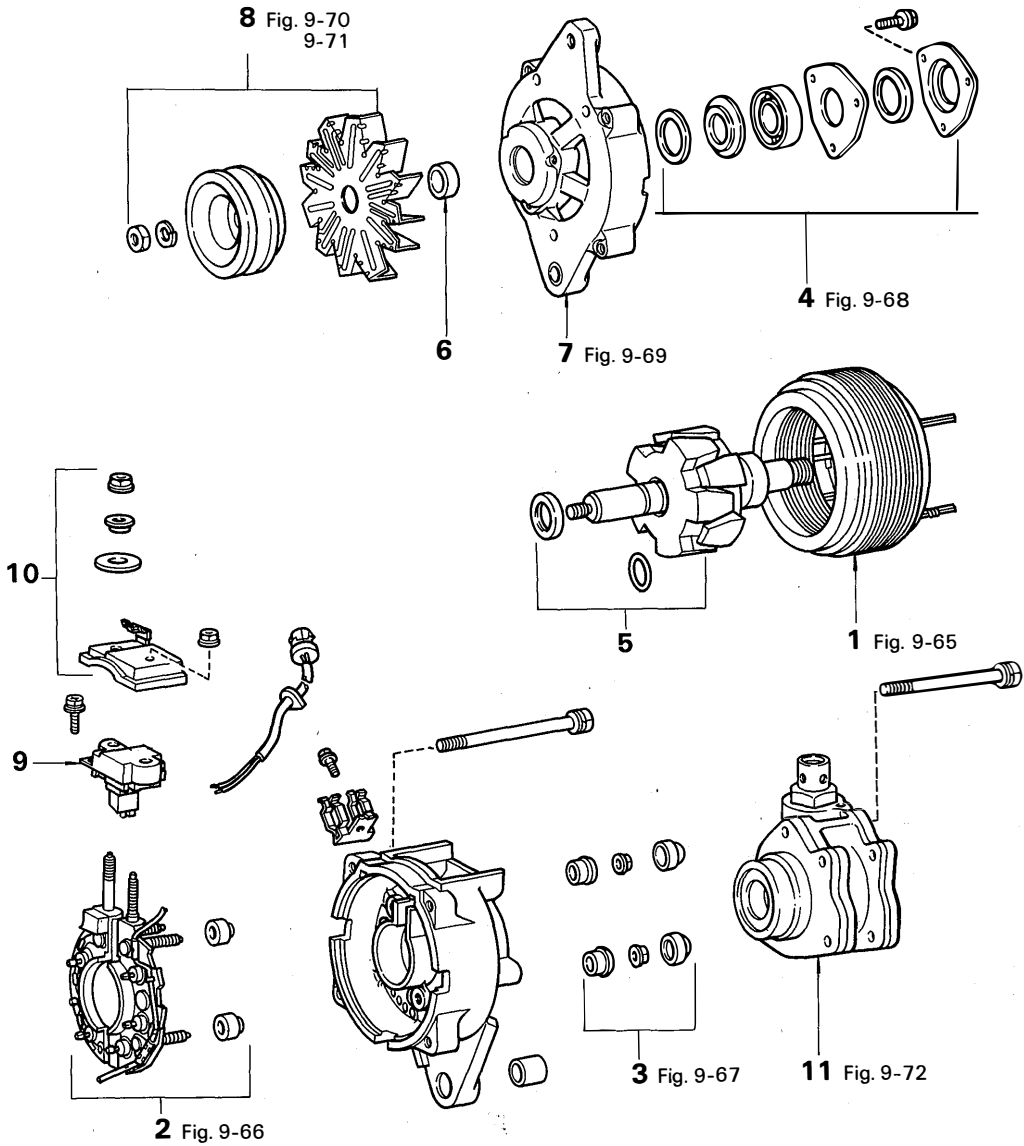

- 1. Stator Coil
- 2. Rectifier Holder & Insulator
- 3. Insulator & Nut
- 4. Front Bearing
- 5. Rotor
- 6. Collar

- 7. Drive End Frame
- 8. Pulley & Fan
- 9. Brush Holder with IC Regulator
- 10. Brush Cover
- 11. Vacuum Pump

Fig. 9-65

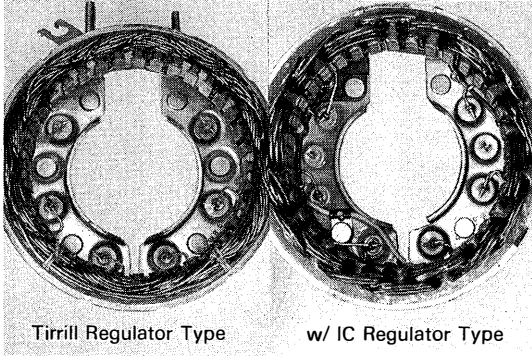

Solder each lead wire onto the rectifier or terminal as shown in the figure.

-Note-

When soldering the leads, hold the rectifier terminal with a long nose pliers to protect the rectifier from heat.

Fig. 9-66

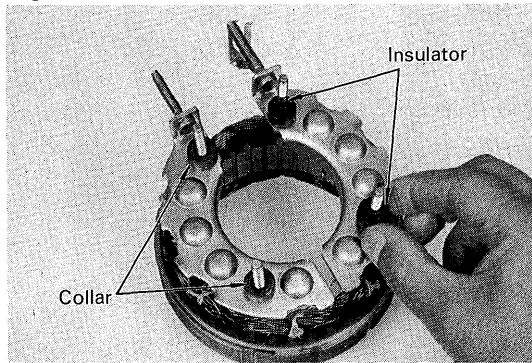

Install the insulator to the rectifier \oplus holder and the collar to \ominus holder.

Fig. 9-67

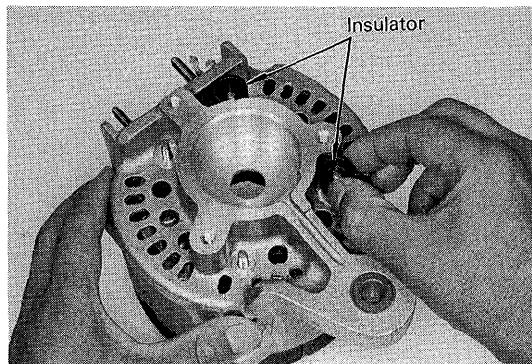

Assemble the rectifier end frame with the insulators.

Fig. 9-68

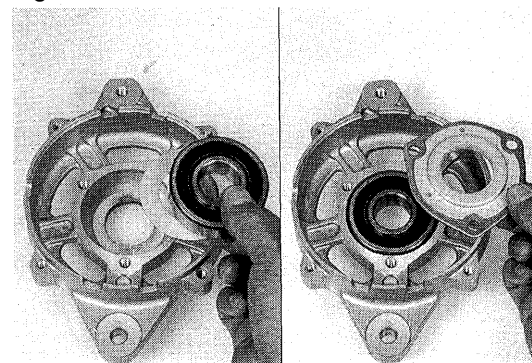

Install the bearing and retainers.

-Note-

Tap the bearing lightly with a plastic hammer if necessary.

Fig. 9-69

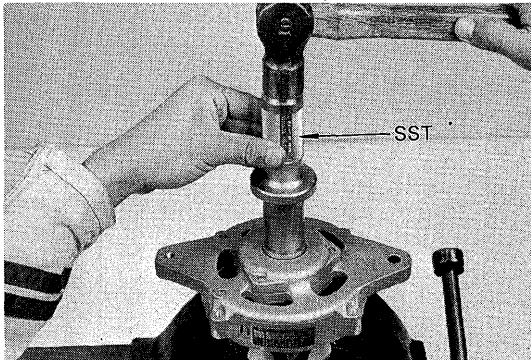

Insert the drive end frame together with a collar into the rotor with SST.
SST [09325-12010]

Fig. 9-70

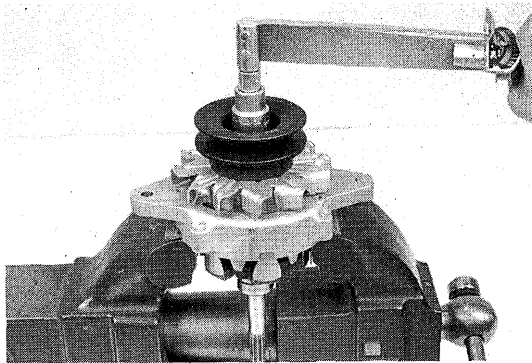

Using a soft jaw vise, tighten the pulley nut.
Tightening torque: 8.0 – 10.0 kg-m
(58 – 72 ft-lb)

Fig. 9-71

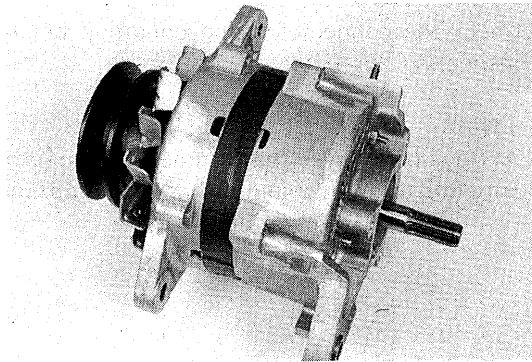

Align the bolt hole of the drive end frame with that of rectifier end frame.

Fig. 9-72

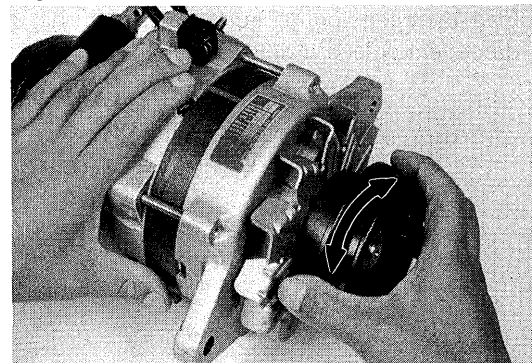

Check the rotor for smooth rotation after assembly is completed.

ALTERNATOR REGULATOR

Fig. 9-73

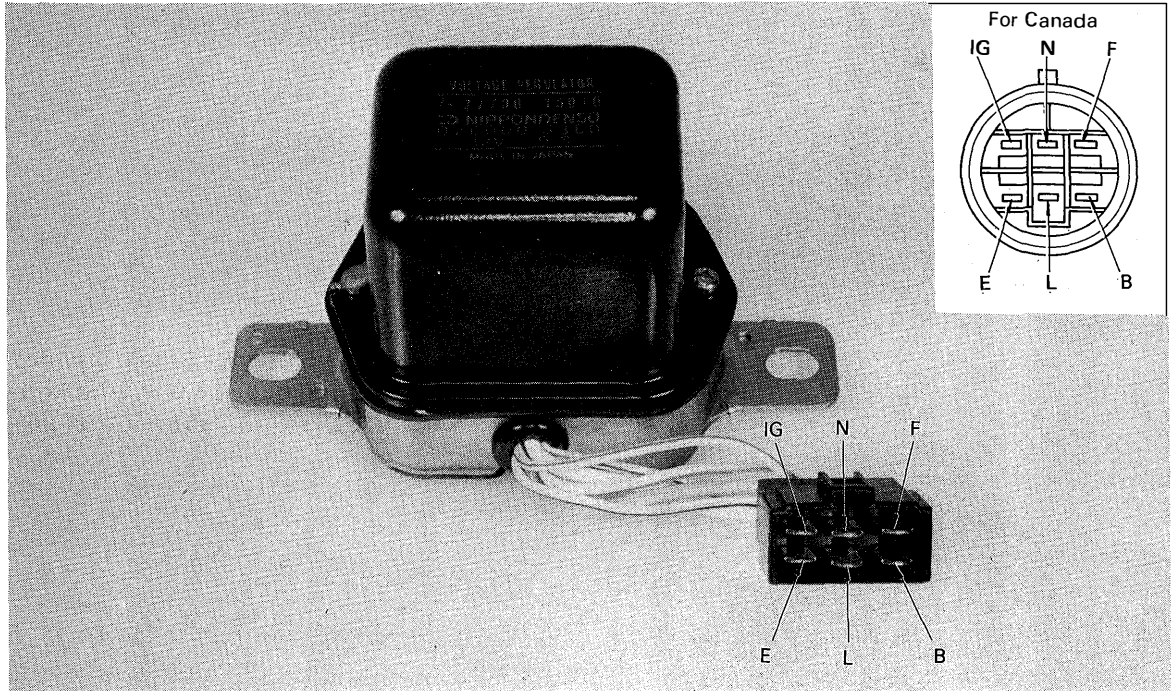
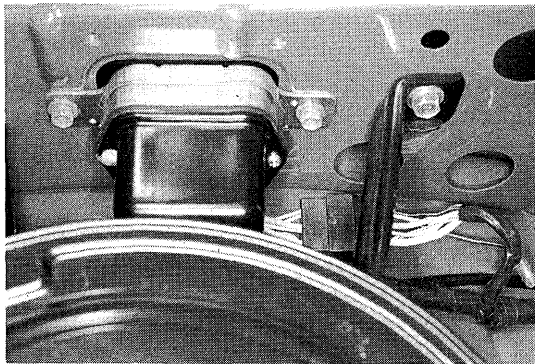

Fig. 9-74



INSPECTION & ADJUSTMENT

Check the connector fitting condition before inspecting the regulator.

—Note—

Always make sure that regulator connector is pulled out when inspecting and adjusting.

Fig. 9-75

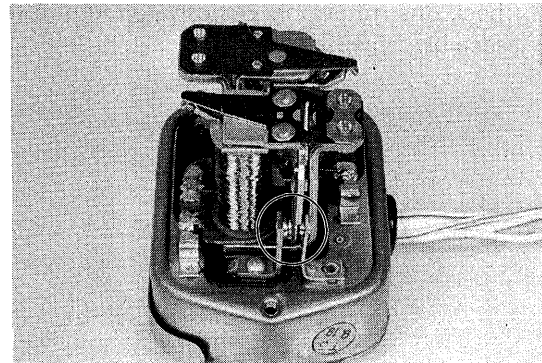

Inspect each point surface for burns or damage. Replace if defective.

Fig. 9-76

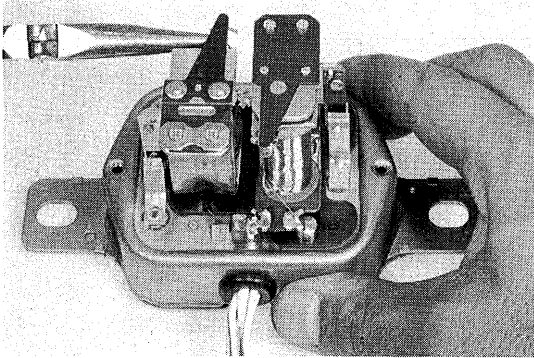

Voltage adjustment

To adjust, bend the voltage regulator adjusting arm.

Regulated voltage:

12V Type 13.8 – 14.8V

24V Type 27 – 29V

Fig. 9-77

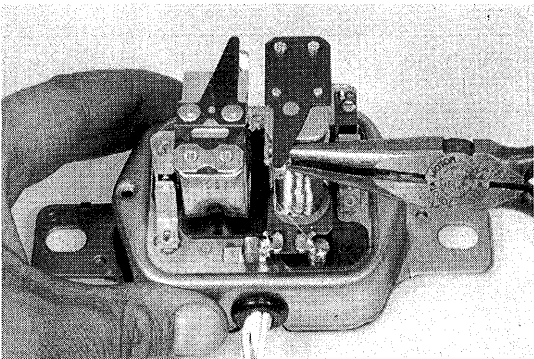

To adjust the voltage relay, bend the relay adjusting arm.

Relay actuating voltage:

12V Type 4.0 – 5.8V

24V Type 8.0 – 11.6V

Fig. 9-78

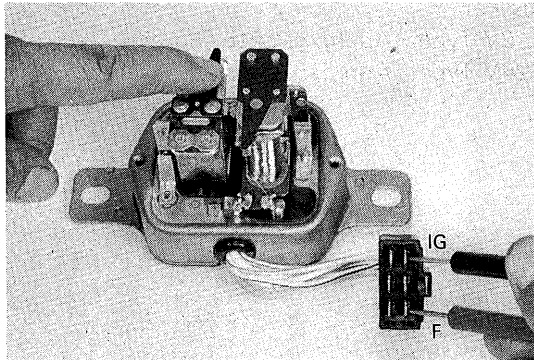

Resistance measurement between the terminals.

IG – F

Voltage regulator	12V Type	24V Type
Open	0Ω	0Ω
Closed	Approx. 11Ω	Approx. 200Ω

Fig. 9-79

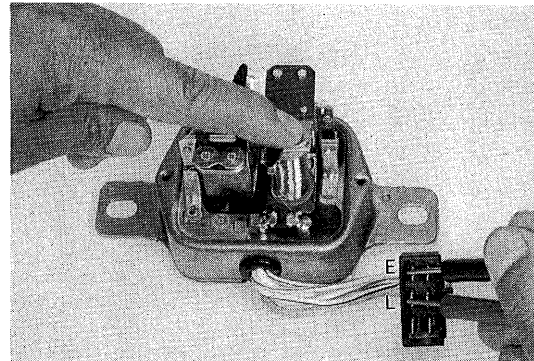

L – E

Voltage relay	12V Type	24V Type
Open	0Ω	0Ω
Closed	Approx. 100Ω	Approx. 200Ω

Fig. 9-80

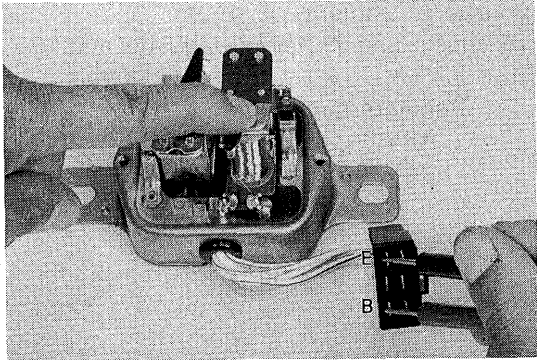

B - E

Voltage relay	12V Type	24V Type
Open	Infinity	Infinity
Closed	Approx. 100Ω	Approx. 200Ω

Fig. 9-81

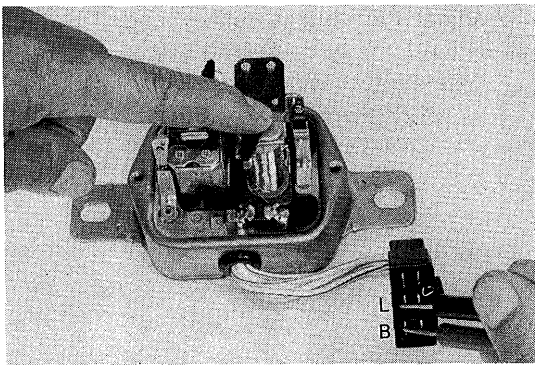

B - L

Voltage relay	12V Type	24V Type
Open	Infinity	Infinity
Closed	0Ω	0Ω

Fig. 9-82

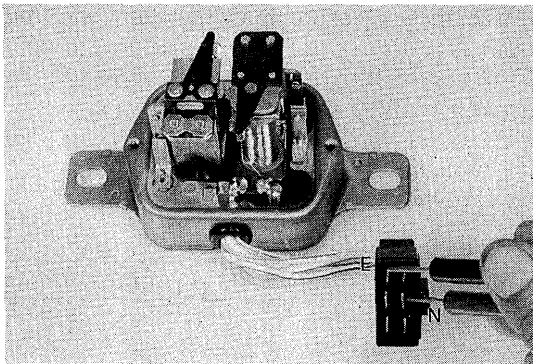

N - E

12V Type Approx. 24Ω
24V Type Approx. 100Ω

WARNING LIGHT RELAY CIRCUIT

Fig. 9-83

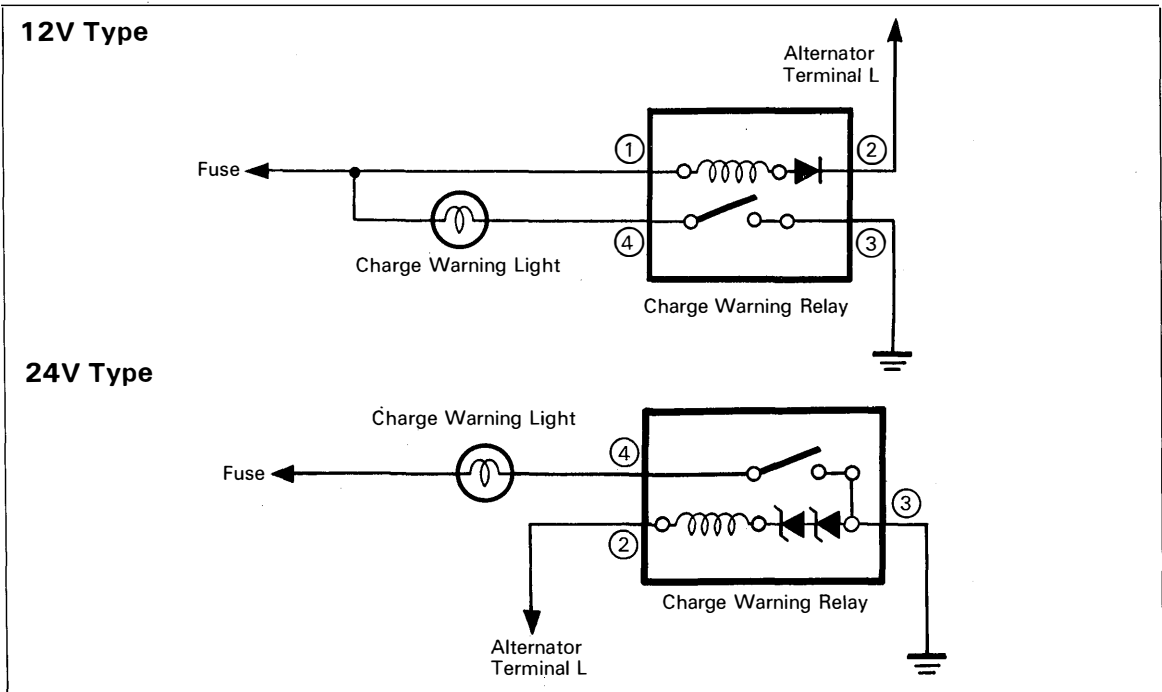
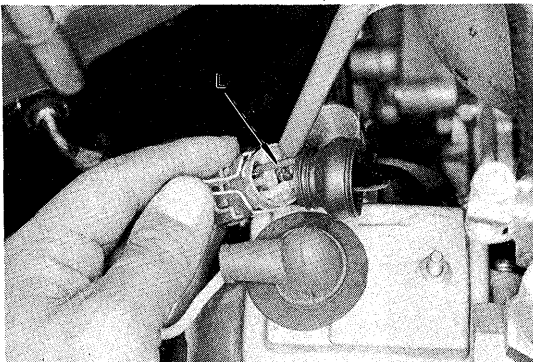

Fig. 9-84



1. After turning the starter switch to ON position measure the voltage at alternator terminal L.

**Voltage: Below 1 – 2V
than battery voltage**

Fig. 9-85

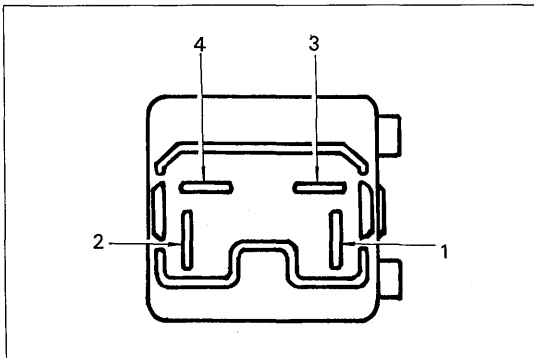

2. Measure the resistance between the terminals as indicated below:
 12V Type—Between 1st and 2nd terminals
 24V Type—Between 3rd and 4th terminals

Resistance:

12V Type 75 – 120 Ω

24V Type 200 – 400 Ω

SST & SERVICE SPECIFICATIONS

	Page
SST (SPECIAL SERVICE TOOLS)	10-2
STANDARD BOLT	
TIGHTENING TORQUE	10-12
TIGHTENING TORQUE	
FOR MAIN PARTS	10-14
SERVICE SPECIFICATIONS	10-15

SST (SPECIAL SERVICE TOOLS)

ENGINE TUNE-UP

Oil Filter

Illustration	Tool No.	Tool Name
	09228-44010	Oil Filter Wrench

Fuel Filter

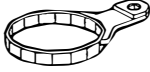
Illustration	Tool No.	Tool Name
	09228-34010	Oil Filter Wrench

Compression Pressure

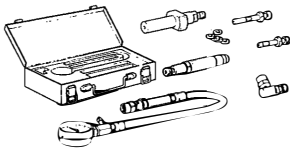
Illustration	Tool No.	Tool Name
	09992-00021	Cylinder Compression Check Gauge Set

ENGINE SERVICE

Cylinder Head

Illustration	Tool No.	Tool Name
	09201-60011	Valve Stem Guide Remover & Replacer

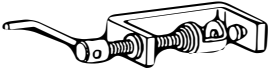
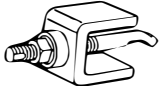
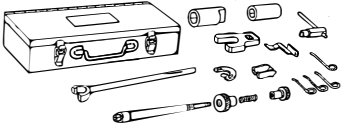
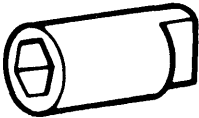

Cylinder Head (Cont'd)

Illustration	Tool No.	Tool Name
	09202-43012	Valve Spring Compressor
	09208-48010	Combustion Chamber Remover
	09260-46011	Injection Pump Tool Set
	(09268-46011)	(Nozzle Holder Body Wrench)

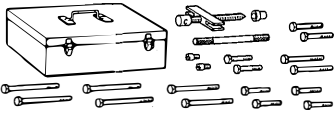
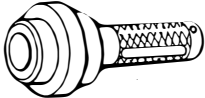
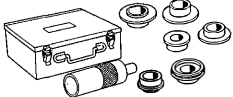
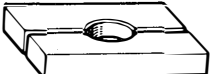
Timing Gear

Illustration	Tool No.	Tool Name
	09213-60016	Crankshaft Pulley & Gear Puller
	09223-46011	Crankshaft Front Oil Seal Replacer
	09316-60010	Transmission & Transfer Bearing Replacer
	09527-21011	Rear Axle Shaft Bearing Remover

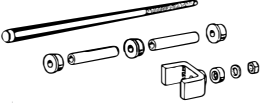
Cylinder Block

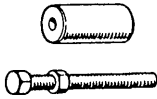
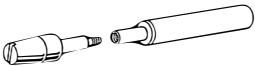
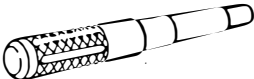
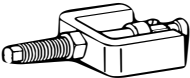
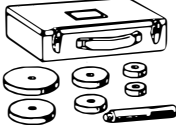
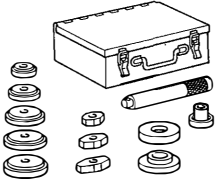
Illustration	Tool No.	Tool Name
	09215-56010	Camshaft Bearing Remover & Replacer
	09218-56020	Cylinder Liner Remover & Replacer
	09218-56030	Cylinder Liner Remover & Replacer
	09219-56010	Piston Cooler Remover
	09221-46010	Piston Pin Remover & Replacer
	09222-66010	Connecting Rod Bushing Remover & Replacer
	09303-35010	Input Shaft Front Bearing Puller
	09550-55010	Differential Replacer Set
	09608-20011	Front Hub & Drive Pinion Bearing Tool Set

LUBRICATION SYSTEM**Oil Filter**

Illustration	Tool No.	Tool Name
	09228-44010	Oil Filter Wrench

Oil Pump

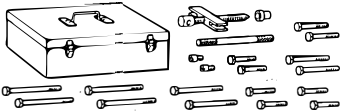
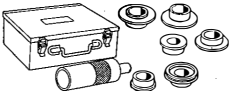
Illustration	Tool No.	Tool Name
	09213-60016	Crankshaft Pulley & Gear Puller
	09316-60010	Transmission & Transfer Bearing Replacer

COOLING SYSTEM**Water Pump**

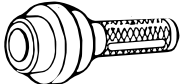
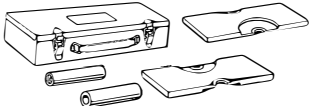
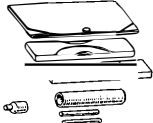
Illustration	Tool No.	Tool Name
	09223-50010	Crankshaft Front Oil Seal Replacer
	09236-28011	Water Pump Overhaul Tool
	09236-36010	Water Pump Overhaul Tool

Water Pump (Cont'd)

Illustration	Tool No.	Tool Name
	09527-10010	Rear Axle Shaft Bearing Remover

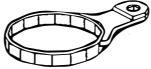

FUEL SYSTEM**Fuel Filter**

Illustration	Tool No.	Tool Name
	09228-34010	Oil Filter Wrench

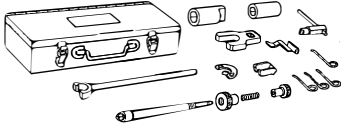
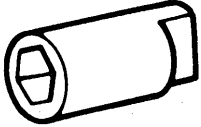
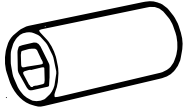
Injection Nozzle

Illustration	Tool No.	Tool Name
	09260-46011	Injection Pump Tool Set
	(09268-46011)	(Nozzle Holder Body Wrench)
	(09268-46021)	(Nozzle Holder Retaining Nut Wrench)

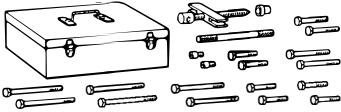
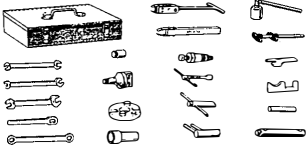

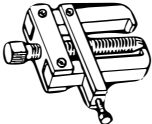
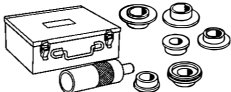
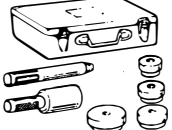



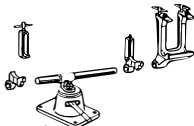

Automatic Timer

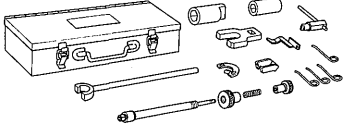
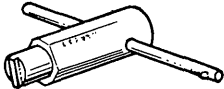
Illustration	Tool No.	Tool Name
	09213-60016	Crankshaft Pulley & Gear Puller
	09260-76016	Injection Pump Tool Set
	(09280-76010)	(Automatic Timer Spring Holder)
	09286-46011	Injection Pump Spline Shaft Puller
	09316-60010	Transmission & Transfer Bearing Replacer
	09620-30010	Steering Gear Box Replacer Set

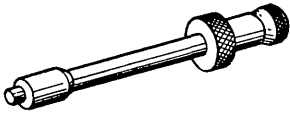

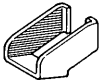

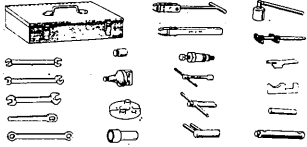

Injection Pump

Illustration	Tool No.	Tool Name
	09241-76021	Injection Pump Stand Set

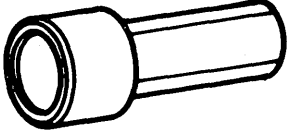
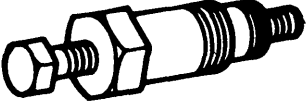

Injection Pump (Cont'd)

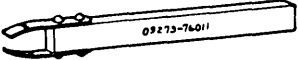
Illustration	Tool No.	Tool Name
	<p>09260-46011</p>	<p>Injection Pump Tool Set</p>
     	<p>(09266-46011)</p> <p>(09274-46010)</p> <p>(09275-46010)</p> <p>(09278-46010)</p> <p>(09280-46010)</p> <p>(09283-46010)</p>	<p>(Round Nut Wrench)</p> <p>(Tappet Insert)</p> <p>(Plunger Clamp)</p> <p>(Spline Shaft Holding Tool)</p> <p>(Plunger Spring Holder)</p> <p>(Tappet Holder Attachment Gauge)</p>
	<p>09260-76016</p>	<p>Injection Pump Tool Set</p>
	<p>(09262-76010)</p>	<p>(Delivery Valve Gasket Replacer)</p>

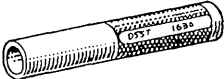
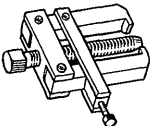
Injection Pump (Cont'd)

Illustration	Tool No.	Tool Name
	(09266-67011)	(Fly Weight Round Nut Wrench)
	(09267-76011)	(Automatic Timer Extractor)
	(09270-76010)	(Delivery Valve Holder)
	(09271-76011)	(Delivery Valve Extractor)
	(09272-76011)	(Tappet Roller Clamp)
	(09273-76011)	(Tappet Clamp)
	(09276-76010)	(T Type Box Wrench)
	09285-76010	Injection Camshaft Bearing Cone Replacer
	09286-46011	Injection Pump Spline Shaft Puller

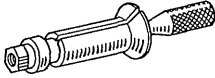
Injection Pump (Cont'd)

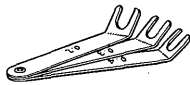
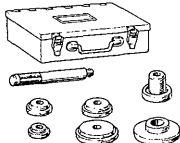
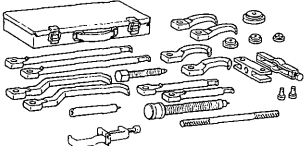
Illustration	Tool No.	Tool Name
	09286-76011	Injection Pump Camshaft Bearing Cup Puller
	09287-76010	Injection Pump Camshaft Bearing Micrometer
	09288-46011	Tappet Adjusting Gauge
	09608-12010	Front Hub & Drive Pinion Bearing Replacer Set
	09950-20014	Universal Puller

STARTING SYSTEM**Starter**

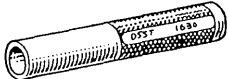
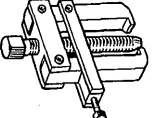
Illustration	Tool No.	Tool Name
	09285-76010	Injection Camshaft Bearing Cone Replacer
	09286-46011	Injection Pump Spline Shaft Puller

CHARGING SYSTEM
On-Vehicle Inspection

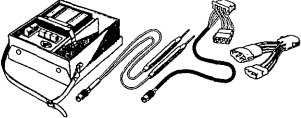
Illustration	Tool No.	Tool Name
	09081-00011	Alternator Checker

Alternator

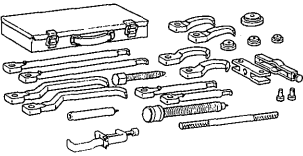
Illustration	Tool No.	Tool Name
	09325-12010	Transmission Oil Plug
	09950-20014	Universal Puller

STANDARD BOLT TIGHTENING TORQUE

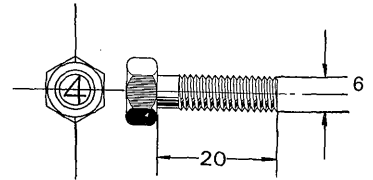
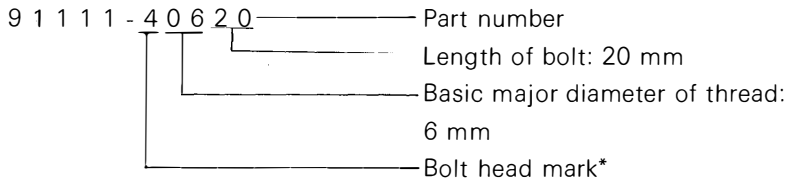

* Explanation of bolt head marks are as indicated in the following table.

SPECIFIED TORQUE FOR STANDARD BOLTS

Class	Basic diameter mm	Pitch mm	Torque limit	kg-m (ft-lb)
4T	6	1	0.4 - 0.7	(3 - 5)
	8	1.25	1.0 - 1.6	(8 - 11)
	10	1.25	1.9 - 3.1	(14 - 22)
	10	1.5	1.8 - 3.0	(14 - 21)
	12	1.25 (ISO)	3.5 - 5.5	(26 - 39)
	12	1.5	3.5 - 5.5	(26 - 39)
	12	1.75	3.0 - 5.0	(22 - 36)
	13	1.5	4.5 - 7.0	(33 - 50)
	14	1.5	5.0 - 8.0	(37 - 57)
	14	2	4.7 - 7.7	(34 - 55)
	16	1.5	7.5 - 11.0	(55 - 79)
	16	2	7.1 - 10.6	(52 - 76)
	5T	6	1	0.6 - 0.9
8		1.25	1.5 - 2.2	(11 - 15)
10		1.25	3.0 - 4.5	(22 - 32)
10		1.5	2.7 - 4.2	(20 - 30)
12		1.25 (ISO)	5.0 - 8.0	(37 - 57)
12		1.5	5.0 - 7.0	(37 - 50)
12		1.75	4.8 - 6.8	(35 - 49)
13		1.5	6.5 - 9.0	(48 - 65)
14		1.5	7.5 - 11.0	(55 - 79)
14		2	7.0 - 10.5	(51 - 75)
16		1.5	12.0 - 17.0	(87 - 122)
16		2	11.5 - 16.5	(84 - 119)
6T		6	1	0.6 - 0.9
	8	1.25	1.5 - 2.2	(11 - 15)
	10	1.25	3.0 - 4.5	(22 - 32)
	10	1.5	2.7 - 4.2	(20 - 30)
	12	1.25 (ISO)	5.0 - 8.0	(37 - 57)
	12	1.5	5.0 - 7.0	(37 - 50)
	12	1.75	4.8 - 6.8	(35 - 49)

SPECIFIED TORQUE FOR STANDARD BOLTS (Cont'd)

Class	Basic diameter mm	Pitch mm	Torque limit	kg-m (ft-lb)
7T	6	1	0.8 – 1.2	(6 – 8)
	8	1.25	2.0 – 3.0	(15 – 21)
	10	1.25	4.0 – 5.5	(29 – 39)
	10	1.5	3.7 – 5.2	(27 – 37)
	12	1.25 (ISO)	7.5 – 10.5	(55 – 75)
	12	1.5	7.0 – 9.0	(51 – 65)
	12	1.75	6.0 – 8.5	(44 – 61)
	13	1.5	8.0 – 12.0	(58 – 86)
	14	1.5	10.0 – 15.0	(73 – 108)
	14	2	9.5 – 14.0	(69 – 101)
	16	1.5	15.0 – 23.0	(109 – 166)
	16	2	14.0 – 22.0	(102 – 159)

– Note –

These torque specifications are applicable only for steel (female) threads. They do not apply to other types of material or if the tightening surface is subjected to heat or vibration.

TIGHTENING TORQUE FOR MAIN PARTS

Tightening part	kg-m	ft-lb	
Cylinder head x Cylinder block	11.5 – 12.0	84 – 87	
Rocker arm support x Cylinder head	1.5 – 2.2	11 – 15	
Intake manifold x Cylinder head	1.5 – 2.2	11 – 15	
Exhaust manifold x Cylinder head	3.0 – 4.5	22 – 32	
Camshaft timing gear x Camshaft	3.0 – 4.5	22 – 32	
Camshaft thrust plate x Cylinder block	1.5 – 2.2	11 – 15	
Idle gear x Idle gear shaft	4.0 – 5.5	29 – 39	
Timing gear cover bolt	8 mm bolt	11 – 15	
	10 mm bolt	22 – 32	
Crankshaft pulley x Crankshaft	20.0 – 24.0	145 – 173	
Crankshaft bearing cap x Cylinder block	12.8 – 14.2	93 – 102	
Connecting rod cap x Connecting rod			
	B, 2B	6.5 – 7.5	48 – 54
	3B	8.5 – 9.5	62 – 68
Oil pan x Cylinder block	0.7 – 1.3	61 – 112 in.-lb	
Flywheel x Crankshaft	12.8 – 14.2	93 – 102	
Nozzle holder x Cylinder head	6.0 – 8.0	44 – 57	
Nozzle retaining nut	5.0 – 7.0	36 – 50	
Injection pipe union nut	1.0 – 1.6	8 – 11	
Delivery valve holder	2.5 – 3.5	19 – 25	

SERVICE SPECIFICATIONS

ENGINE TUNE-UP

Coolant capacity	BJ40, 42, 43, 45 & 46 Series	12.5 liters	13.2 US qt	11.0 Imp.qt	
	BJ60 Series	13.3 liters	14.1 US qt	11.7 Imp.qt	
	BU20, 30 Series	13.1 liters	13.8 US qt	11.5 Imp.qt	
	BB10 Series	14.5 liters	15.3 US qt	12.8 Imp.qt	
Drive belt tension at 10 kg (22 lb) w/o Air con.	New belt	8 – 12 mm	0.31 – 0.47 in.		
	Used belt	11 – 14 mm	0.43 – 0.55 in.		
	w/ Air con. (BB10)	New belt	10 – 13 mm	0.39 – 0.51 in.	
		Used belt	12 – 15 mm	0.47 – 0.59 in.	
	For borroughs belt tension No. BT-33-73F	New belt	120 – 170 lb		
		Used belt	80 – 120 lb		
Battery electrolyte specific gravity					
When fully charged	at 20°C (68°F)	1.25 – 1.27			
Engine oil capacity					
Dry fill		7.3 liters	7.7 US qt	6.4 Imp.qt	
Drain & refill	w/ Oil filter change	6.7 liters	7.1 US qt	5.9 Imp.qt	
	w/o Oil filter change	5.8 liters	6.1 US qt	5.1 Imp.qt	
Compression pressure at 250 rpm	STD	30.0 kg/cm ²	427 psi		
	Limit	20.0 kg/cm ²	284 psi		
	Difference between each cylinder	Less than 2.0 kg/cm ² (28 psi)			
Injection nozzle opening pressure	New nozzle	115 – 125 kg/cm ²	1,636 – 1,778 psi		
	Reused nozzle	105 – 125 kg/cm ²	1,493 – 1,778 psi		
Injection timing	Stationary	14° BTDC			
Injection order		1 – 3 – 4 – 2			
Valve clearance	Hot	Intake	0.20 mm	0.008 in.	
		Exhaust	0.36 mm	0.014 in.	
Idle speed		650 rpm			
Maximum speed	No-load	4,050 – 4,100 rpm			

ENGINE

Cylinder Head

Surface warpage	Limit	0.2 mm	0.008 in.
Manifold mounting surface warpage	Limit	0.2 mm	0.008 in.
Valve seat			
Contacting surface angle		45°	
Contacting width		1.2 – 1.6 mm	0.047 – 0.063 in.
Refacing angle		30°, 45°, 60°	

Combustion Chamber

Protrusion amount	0 – 0.10 mm	0 – 0.0039 in.
-------------------	-------------	----------------

Valve & Guide Bushing

Valve				
Head edge thickness	Limit	Intake	0.9 mm	0.035 in.
		Exhaust	1.3 mm	0.051 in.
Face angle		IN & EX	44.5°	
Overall length	STD	Intake	127.95 mm	5.0374 in.
		Exhaust	127.75 mm	5.0295 in.
Stem end refacing	Limit	IN & EX	0.5 mm	0.020 in.
Stem diameter		Intake	8.968 – 8.984 mm	0.3531 – 0.3537 in.
		Exhaust	8.954 – 8.970 mm	0.3525 – 0.3531 in.
Stem oil clearance	STD	Intake	0.026 – 0.062 mm	0.0010 – 0.0024 in.
		Exhaust	0.040 – 0.076 mm	0.0016 – 0.0030 in.
	Limit	Intake	0.10 mm	0.0039 in.
		Exhaust	0.12 mm	0.0047 in.
Guide bushing				
Inner diameter			9.01 – 9.03 mm	0.3547 – 0.3555 in.
Protrusion from cylinder head			15.4 – 16.0 mm	0.61 – 0.63 in.

Valve Spring

Free length		Outer	45.5 mm	1.791 in.
		Inner	47.5 mm	1.870 in.
Installed length		Outer	39.6 mm	1.559 in.
		Inner	36.1 mm	1.421 in.
Installed load	STD	Outer	25.6 kg	56 lb
		Inner	5.95 kg	13 lb
	Limit	Outer	21.0 kg	46.3 lb
		Inner	4.9 kg	10.8 lb
Squareness		Limit	2.0 mm	0.079 in.

Valve Rocker Arm & Shaft

Shaft diameter	Limit	18.44 mm	0.7260 in.
Rocker arm bore	Limit	18.60 mm	0.7323 in.
Oil clearance	STD	0.02 – 0.06 mm	0.0008 – 0.0024 in.
	Limit	0.1 mm	0.004 in.

Valve Lifter

Oil clearance	STD	0.02 – 0.05 mm	0.0008 – 0.0020 in.
	Limit	0.1 mm	0.004 in.
Outer diameter	STD	23.972 – 23.985 mm	0.9438 – 0.9443 in.

Camshaft

Circle runout	Limit	0.04 mm	0.0016 in.
Thrust clearance	STD	0.06 – 0.13 mm	0.0024 – 0.0051 in.
	Limit	0.3 mm	0.012 in.
Oil clearance	STD	0.03 – 0.07 mm	0.0012 – 0.0028 in.
	Limit	0.1 mm	0.004 in.
Journal diameter	No.1	47.16 – 47.18 mm	1.8567 – 1.8575 in.
	No.2	46.96 – 46.98 mm	1.8488 – 1.8496 in.
	No.3	46.76 – 46.78 mm	1.8409 – 1.8417 in.
Cam height	STD	39.47 – 39.56 mm	1.5539 – 1.5575 in.
	Limit	39.0 mm	1.535 in.

Timing & Idle Gear

Gear backlash Idle gear to cam gear, timer drive gear	STD	0.06 – 0.09 mm	0.0024 – 0.0035 in.
	Limit	0.3 mm	0.012 in.
Crankshaft to idle gear	STD	0.06 – 0.10 mm	0.0024 – 0.0039 in.
	Limit	0.3 mm	0.012 in.
Idle gear thrust clearance	STD	0.08 – 0.20 mm	0.0031 – 0.0079 in.
	Limit	0.3 mm	0.012 in.
Idle gear oil clearance	STD	0.04 – 0.09 mm	0.0016 – 0.0035 in.
	Limit	0.3 mm	0.012 in.
Idle gear bore	STD	45.00 – 45.03 mm	1.7717 – 1.7728 in.
Idle gear shaft diameter	STD	44.94 – 44.96 mm	1.7693 – 1.7701 in.
	Limit	44.91 mm	1.7681 in.

Manifold

Installing surface warpage	Limit	0.4 mm	0.016 in.
----------------------------	-------	--------	-----------

Cylinder Block

Warpage	Limit	0.2 mm	0.008 in.
Valve lifter bore diameter	STD	24.00 – 24.02 mm	0.9449 – 0.9457 in.
Cylinder bore diameter	STD B	95.00 – 95.03 mm	3.7402 – 3.7413 in.
	2B	98.00 – 98.03 mm	3.8583 – 3.8594 in.
	3B	102.00 – 102.03 mm	4.0157 – 4.0169 in.
Liner			
Max. wear	Limit	0.3 mm	0.012 in.
Pressing force		2,500 kg	5,500 lb
Protrusion		0.01 – 0.10 mm	0.0004 – 0.0039 in.
Shim thickness		0.05, 0.10 mm	0.0020, 0.0039 in.

Piston & Piston Ring

Piston diameter	STD B	94.88 – 94.91 mm	3.7354 – 3.7366 in.
	2B	97.88 – 97.91 mm	3.8535 – 3.8547 in.
	3B	101.90 – 101.93 mm	4.0118 – 4.0130 in.
	O/S 1.00 B	95.88 – 95.91 mm	3.7748 – 3.7760 in.
Piston oil clearance		0.11 – 0.13 mm	0.0043 – 0.0051 in.
Piston ring end gap	No.1 B	0.35 – 0.55 mm	0.0138 – 0.0217 in.
	2B & 3B	0.40 – 0.60 mm	0.0157 – 0.0236 in.
	No.2 B	0.35 – 0.55 mm	0.0138 – 0.0217 in.
	2B & 3B	0.40 – 0.60 mm	0.0157 – 0.0236 in.
	Oil B	0.35 – 0.55 mm	0.0138 – 0.0217 in.
	2B & 3B	0.40 – 0.60 mm	0.0157 – 0.0236 in.
Piston ring to ring groove clearance	No.1	0.04 – 0.08 mm	0.0016 – 0.0031 in.
	No.2	0.04 – 0.08 mm	0.0016 – 0.0031 in.
	Oil	0.03 – 0.07 mm	0.0012 – 0.0028 in.
Piston pin diameter	B & 2B	29.00 – 29.01 mm	1.1417 – 1.1421 in.
	3B	32.00 – 32.01 mm	1.2598 – 1.2602 in.
Piston pin installing temperature		60°C	140°F

Connecting Rod

Thrust clearance	STD	0.08 – 0.20 mm	0.0031 – 0.0079 in.
	Limit	0.3 mm	0.012 in.
Bushing oil clearance	STD	0.004 – 0.014 mm	0.0002 – 0.0006 in.
	Limit	0.05 mm	0.0020 in.

Crankshaft

Circle runout	Limit		0.06 mm	0.0024 in.	
Thrust clearance	STD		0.07 – 0.18 mm	0.0028 – 0.0071 in.	
	Limit		0.3 mm	0.012 in.	
Main journal					
Diameter	STD		69.98 – 70.00 mm	2.7551 – 2.7559 in.	
	U/S finished diameter	U/S 0.25	69.74 – 69.75 mm	2.7457 – 2.7461 in.	
		U/S 0.50	69.49 – 69.50 mm	2.7358 – 2.7362 in.	
		U/S 1.00	68.99 – 69.00 mm	2.7161 – 2.7165 in.	
Taper and out-of-round	Limit	0.02 mm	0.0008 in.		
Oil clearance	STD		0.03 – 0.07 mm	0.0012 – 0.0028 in.	
	Limit		0.1 mm	0.004 in.	
Bearing type			STD, U/S (0.25, 0.50, 1.00)		
Crank pin journal					
Diameter	STD	B & 2B	58.98 – 59.00 mm	2.3220 – 2.3228 in.	
		3B	60.98 – 61.00 mm	2.4008 – 2.4016 in.	
U/S finished diameter B & 2B		U/S 0.25	58.74 – 58.75 mm	2.3126 – 2.3130 in.	
		U/S 0.50	58.49 – 58.50 mm	2.3028 – 2.3031 in.	
		U/S 1.00	57.99 – 58.00 mm	2.2831 – 2.2835 in.	
		3B	U/S 0.25	60.74 – 60.75 mm	2.3913 – 2.3917 in.
			U/S 0.50	60.49 – 60.50 mm	2.3815 – 2.3819 in.
			U/S 1.00	59.99 – 60.00 mm	2.3618 – 2.3622 in.
Taper and out-of-round	Limit	0.02 mm	0.0008 in.		
Oil clearance	STD		0.03 – 0.07 mm	0.0012 – 0.0028 in.	
	Limit		0.1 mm	0.004 in.	
Bearing type			STD, U/S (0.25, 0.50, 1.00)		

Flywheel

Runout	Limit	0.2 mm	0.008 in.
--------	-------	--------	-----------

LUBRICATION SYSTEM**Oil Pump**

Tip clearance				
Driven gear to crescent	STD	0.15 – 0.21 mm	0.0059 – 0.0083 in.	
	Limit	0.3 mm	0.012 in.	
Drive gear to crescent	STD	0.22 – 0.25 mm	0.0087 – 0.0098 in.	
	Limit	0.3 mm	0.012 in.	
Side clearance	STD	0.03 – 0.09 mm	0.0012 – 0.0035 in.	
	Limit	0.15 mm	0.0059 in.	
Body clearance	STD	0.06 – 0.15 mm	0.0024 – 0.0059 in.	
	Limit	0.3 mm	0.012 in.	

COOLING SYSTEM**Water Pump**

Bearing installing temperature	Normal temperature
--------------------------------	--------------------

Radiator

Radiator cap relief valve opening pressure			
	STD	0.75 – 1.05 kg/cm ²	10.7 – 14.9 psi
	Limit	0.6 kg/cm ²	8.5 psi

Thermostat

Valve opening temperature	Low temp. type		High temp. type	
Starts to open at	80.5 – 83.5°C	177 – 182°F	86.5 – 89.5°C	188 – 193°F
Fully opens at	95°C	203°F	100°C	212°F
Valve opening travel	10 mm	0.39 in.	10 mm	0.39 in.

FUEL SYSTEM**Fuel Pump**

Housing to piston clearance	0.009 – 0.013 mm	0.0004 – 0.0005 in.
Housing to push rod clearance	0.003 – 0.006 mm	0.0001 – 0.0002 in.

Fuel Pump Performance Test

Suction test			
Suction pipe			
Inner diameter		8 mm	0.31 in.
Length		2 m	78.74 in.
Suction height		1 m	39.37 in.
Feed pump	at 150 rpm	Fuel must discharge within 40 seconds	
Priming pump	at 60 strokes/min.	Fuel must discharge within 25 strokes	
Discharge test			
Discharge nozzle diameter		1.54 mm	0.0606 in.
Pressure	at 600 rpm	1.8 – 2.2 kg/cm ²	26 – 31 psi
Volume	at 1,000 rpm	More than 900 cc/min. (54.9 cu in./min.)	

Injection Nozzle & Nozzle Holder

Nozzle opening pressure	New nozzle	115 – 125 kg/cm ²	1,636 – 1,778 psi
	Reused nozzle	105 – 125 kg/cm ²	1,493 – 1,778 psi
Nozzle injection angle		About 4°	
Adjusting shim thickness		1.00...1.95 mm	0.0394...0.0768 in.
(For adjusting nozzle opening pressure)		[20 sizes in 0.05 mm (0.0020 in.) increments]	

Automatic Timer

Timer installing temperature		60°C	140°F
Timer advance angle	B & 2B	700 rpm	Advance begins ($\leq 0.5^\circ$)
		900 rpm	2.7 – 3.7°
		1,100 rpm	3.5 – 4.5°
		1,450 rpm	4.8 – 5.8°
		1,750 rpm	6.0 – 7.0°
	3B	1,850 rpm	6.0 – 7.0°
		700 rpm	Advance begins ($\leq 0.5^\circ$)
		1,000 rpm	1.3 – 2.3°
		1,400 rpm	3.7 – 4.7°
		1,750 rpm	6.0 – 7.0°
	1,900 rpm	6.0 – 7.0°	
Adjusting shim thickness		0.1, 0.2, 0.5 mm	0.004, 0.008, 0.020 in.

Injection Pump

Direction of rotation		Clockwise as seen from drive side
Cam lift		8.0 mm 0.315 in.
Injection order		1 – 3 – 4 – 2
Control rack sliding resistance		
	Pump at 0 rpm	Less than 120g (4.2 oz)
	Pump at 1,000 rpm	Less than 50g (1.8 oz)
Pre-stroke		
Control rack at 8.0 mm (0.315 in.)		1.9 – 2.0 mm 0.075 – 0.079 in.
Injection interval		89.5 – 90.5°
Tappet clearance		More than 0.2 mm (0.008 in.)
Tappet adjusting shim thickness		0.1...1.4 & 0.15 mm (0.004...0.055 & 0.006 in.) (14 sizes in 0.1 mm (0.004 in.) increments and 0.15 mm (0.0059 in.)
Tappet overall looseness	Limit	0.3 mm 0.012 in.
Camshaft thrust clearance	STD	0.03 – 0.05 mm 0.0012 – 0.0020 in.
	Limit	0.1 mm 0.004 in.
Camshaft adjusting shim thickness		0.10, 0.12, 0.14, 0.16, 0.18, 0.50 mm (0.0039, 0.0047, 0.0055, 0.0063, 0.0071, 0.0197 in.)
Plunger spring		
Free length		49.4 mm 1.945 in.
Installed length		44.0 mm 1.732 in.
Installed load		15.1 kg 33 lb
Delivery valve spring		
Free length		37.0 mm 1.457 in.
Installed length		25.9 mm 1.020 in.
Installed load		4.42 kg 10 lb

Combined Governor

Main spring		
Free length	B & 2B	45.6 mm 1.795 in.
	3B	51.6 mm 2.031 in.
Installed length	B & 2B	35.0 mm 1.378 in.
	3B	36.5 mm 1.437 in.
Installed load	B & 2B	0.954 kg 2.1 lb
	3B	1.057 kg 2.3 lb
Adjusting shim thickness		0.5, 1.0, 2.0, 3.0 mm (0.020, 0.039, 0.079, 0.118 in.)
Speed control spring		
Free length		38.0 mm 1.496 in.
Installed length		27.0 mm 1.063 in.
Installed load		3.30 kg 7 lb

Diesel High Altitude Compensator (DHAC)

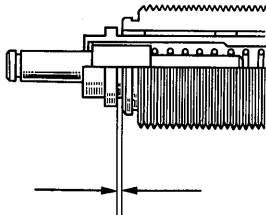
Clearance (at sea level)	0.1 – 0.3 mm	0.004 – 0.012 in.
		

INJECTION PUMP ADJUSTMENT & TEST**Preparations of Pump Tester**

Nozzle type	ND-DN4 SD-24A	
Nozzle opening pressure	115 – 125 kg/cm ²	1,636 – 1,779 psi
Outer diameter	6.0 mm	0.236 in.
Inner diameter	2.0 mm	0.079 in.
Length	600 mm	23.62 in.
Minimum bending radius	More than 25 mm (1.0 in.)	
Fuel temperature	40 – 45°C	104 – 113°F
Fuel feeding pressure	0.5 kg/cm ²	7 psi

Control Rack

Sliding resistance	Pump at 0 rpm	Less than 120g (4.2 oz)
	Pump at 1,000 rpm	Less than 50g (1.8 oz)

Injection Timing

Pre-stroke		
Control rack position at 8.0 mm (0.315 in.)	1.9 – 2.0 mm	0.075 – 0.079 in.
Injection interval	89.5 – 90.5°	
Tappet clearance	More than 0.2 mm (0.008 in.)	

Injection Volume Adjustment**[For B Engine]**

Rack position mm (in.)	Pump revolution (rpm)	Measuring strokes	Injection volume cc (cu in.)	Variation limit cc (cu in.)
16.0 (0.630)	100	200	14.0 – 16.0 (0.85 – 0.98)	1.2 (0.07)
11.7 (0.461)	1,100	200	10.0 – 10.6 (0.61 – 0.65)	0.4 (0.02)
8.6 (0.339)	1,000	200	4.6 – 5.6 (0.28 – 0.34)	0.4 (0.02)
6.5 (0.256)	325	500	2.5 – 4.5 (0.15 – 0.27)	1.0 (0.06)

[For 2B Engine]

Rack position mm (in.)	Pump revolution (rpm)	Measuring strokes	Injection volume cc (cu in.)	Variation limit cc (cu in.)
16.0 (0.630)	100	200	14.0 – 16.0 (0.85 – 0.98)	1.2 (0.07)
11.9 (0.469)	1,100	200	11.0 – 11.6 (0.67 – 0.71)	0.4 (0.02)
8.0 (0.315)	1,000	200	4.3 – 5.1 (0.26 – 0.31)	0.4 (0.02)
6.5 (0.256)	325	500	2.5 – 4.5 (0.15 – 0.27)	1.0 (0.06)

[For 3B Engine]

Rack position mm (in.)	Pump revolution (rpm)	Measuring strokes	Injection volume cc (cu in.)	Variation limit cc (cu in.)
17.5 (0.689)	100	200	14.0 – 16.0 (0.85 – 0.98)	1.2 (0.07)
13.0 (0.512)	1,100	200	11.3 – 11.9 (0.69 – 0.73)	0.4 (0.02)
13.0 (0.512)	1,700	200	11.5 – 12.5 (0.70 – 0.76)	0.6 (0.04)
8.0 (0.315)	1,000	200	4.3 – 5.1 (0.26 – 0.31)	0.4 (0.02)
6.5 (0.256)	325	500	2.5 – 4.5 (0.15 – 0.27)	1.0 (0.06)

GOVERNOR ADJUSTMENT & TEST
 [For B Engine]
 Characteristic Diagram

PNEUMATIC GOVERNOR SECTION

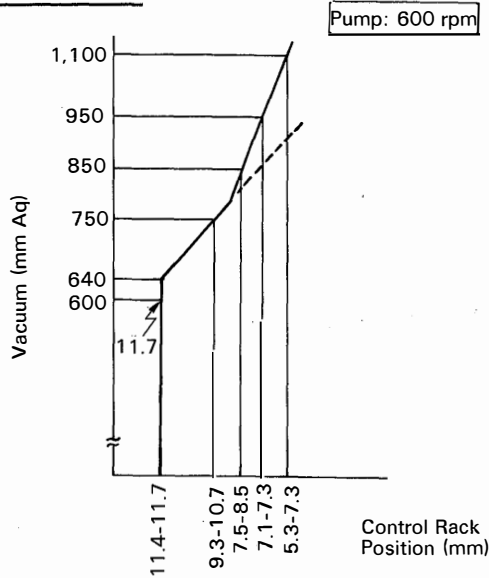

MECHANICAL GOVERNOR SECTION

BJ40 series

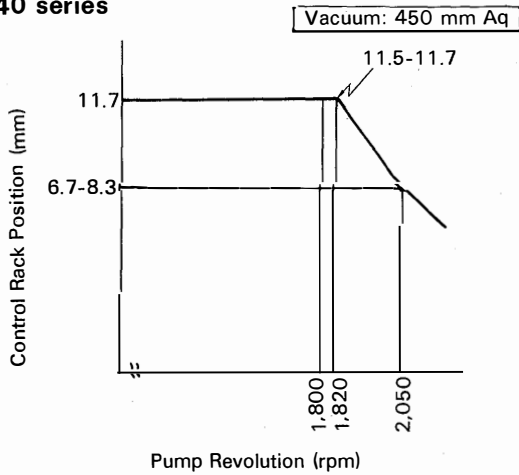

BU20, 30 series

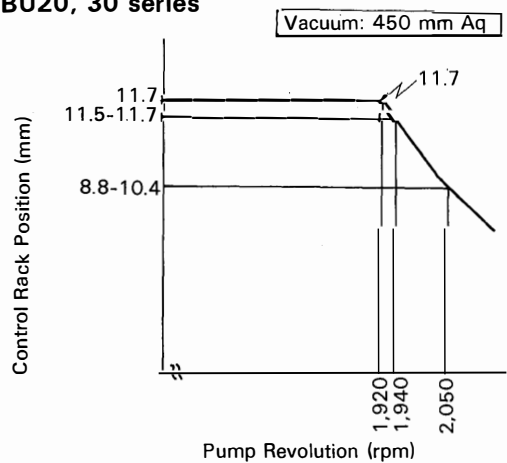

Total Injection Volume

Model	Measuring strokes	Pump revolution	Vacuum	Total injection volume
BJ40	500	1,100 rpm	150 mm Aq (5.91 in. Aq)	101.0 - 105.0 cc (6.16 - 6.41 cu in.)
BU20, 30	500	1,100 rpm	120 mm Aq (4.72 in. Aq)	101.0 - 105.0 cc (6.16 - 6.41 cu in.)

[For 2B Engine]
Characteristic Diagram

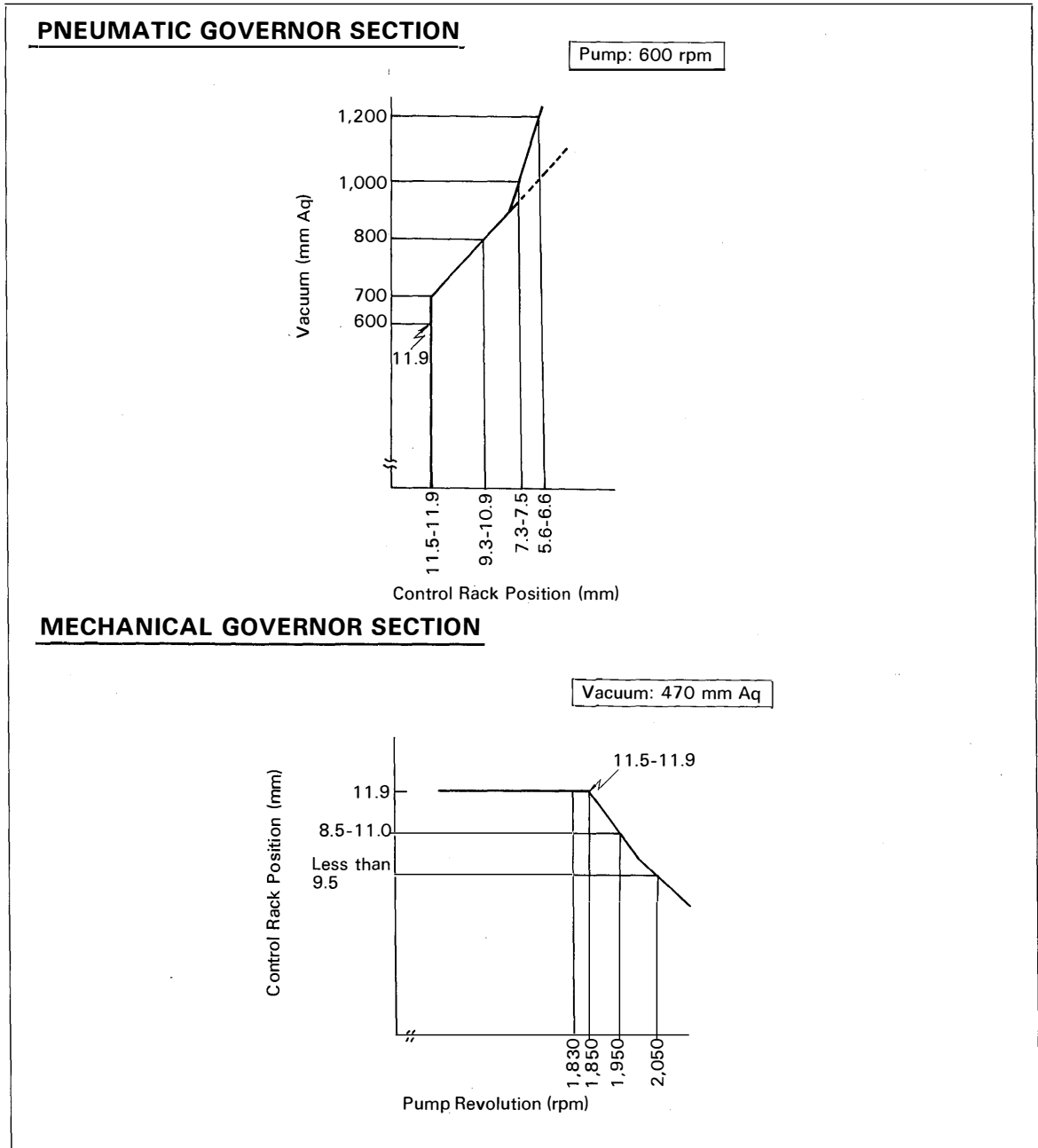

Total Injection Volume

Measuring strokes	Pump revolution	Vacuum	Total injection volume
500	1,100 rpm	200 mm Aq (7.87 in. Aq)	106.0 – 110.0 cc (6.47 – 6.71 cu in.)

[For 3B Engine]
Characteristic Diagram

PNEUMATIC GOVERNOR SECTION

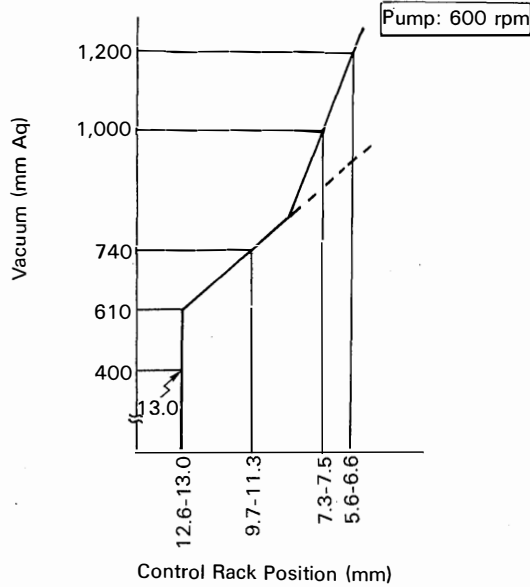

MECHANICAL GOVERNOR SECTION

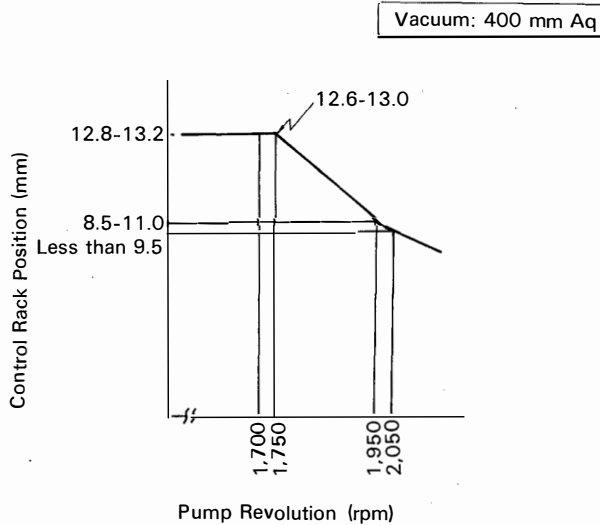

Total Injection Volume

Measuring strokes	Pump revolution	Vacuum	Total injection volume
500	1,100 rpm	260 mm Aq (10.24 in. Aq)	114.0 – 118.0 cc (6.96 – 7.20 cu in.)

Governor Adjustment

Adjustment & test		Pump revolution (rpm)	Vacuum mm Aq (in. Aq)	Control rack position mm (in)	Time/second
Governor air tightness		600	500 → 480 (19.69 → 18.90)	—	More than 10
Control rack initial set	B	600	600 (23.62)	11.7 (0.461)	—
	2B	600	600 (23.62)	11.9 (0.469)	
	3B	600	400 (15.75)	13.0 (0.512)	
Main spring	B	600	640 (25.20)	11.4 – 11.7 (0.449 – 0.461)	—
			750 (29.53)	9.3 – 10.7 (0.366 – 0.421)	
	2B	600	700 (27.56) 800 (31.50)	11.5 – 11.9 (0.453 – 0.469) 9.3 – 10.9 (0.336 – 0.409)	
3B	600	610 (24.02)	12.6 – 13.0 (0.496 – 0.512)		
		740 (29.13)	9.7 – 11.3 (0.382 – 0.445)		
Idling spring capsule	B	600	850 (33.46)	7.5 – 8.5 (0.295 – 0.335)	—
			950 (37.40)	7.1 – 7.3 (0.280 – 0.287)	
			1,100 (43.31)	5.3 – 7.3 (0.209 – 0.287)	
2B	600	1,000 (39.37)	7.3 – 7.5 (0.287 – 0.295)		
		1,200 (47.24)	5.6 – 6.6 (0.220 – 0.260)		
3B	600	1,000 (39.37)	7.3 – 7.5 (0.287 – 0.295)		
		1,200 (47.24)	5.6 – 6.6 (0.220 – 0.260)		

Governor Adjustment (Cont'd)

Adjustment & test		Vacuum mm Aq (in. Aq)	Pump revolution (rpm)	Control rack position mm (in)	Time/seconds
Speed control spring	B (BJ40)	450 (17.72)	1,800	11.7 (0.461)	
			1,820	11.5 – 11.7 (0.453 – 0.461)	
			2,050	6.7 – 8.3 (0.264 – 0.327)	
	B (BU20, 30)	450 (17.72)	1,920	11.7 (0.461)	
			1,940	11.5 – 11.7 (0.453 – 0.461)	
			2,050	8.8 – 10.4 (0.346 – 0.409)	
	2B	470 (18.50)	1,830	11.9 (0.469)	
			1,850	11.5 – 11.9 (0.453 – 0.469)	
			1,950	8.5 – 11.0 (0.335 – 0.433)	
			2,050	Less than 9.5 (0.374)	
	3B	400 (15.75)	1,700	12.8 – 13.2 (0.504 – 0.520)	
			1,750	12.6 – 13.0 (0.496 – 0.512)	
1,950			8.5 – 11.0 (0.335 – 0.443)		
2,050			Less than 9.5 (0.374)		

Total Injection Volume

Engine	Model	Measuring strokes	Pump revolution (rpm)	Vacuum mm Aq (in. Aq)	Total injection volume cc (cu in.)
B	BJ40	500	1,100	150 (5.91)	101.0 – 105.0 (6.16 – 6.41)
	BU20, 30	500	1,100	120 (4.72)	101.0 – 105.0 (6.16 – 6.41)
2B		500	1,100	200 (7.87)	106.0 – 110.0 (6.47 – 6.71)
3B		500	1,100	260 (10.24)	114.0 – 118.0 (6.96 – 7.20)

EDIC (ELECTRICAL DIESEL INJECTION CONTROL) SYSTEM

Operational Check

<p>Injection pump lever position</p> <p>A: 41° 35° (w/ DHAC)</p> <p>B: B & 2B 19.5° 3B 22.5°</p> <p>C: B & 2B 49° 3B 52°</p>	
--	--

STARTING SYSTEM

Preheating System

Type		12V	24V
Glow time	at 0°C (32°F)	About 15 seconds	—
Load current per one glow plug			
	BJ60	7.2 – 9.8A	3.8 – 5.2A
	ex. BJ60	7.6 – 10.4A	4.1 – 5.5A
Glow plug resistance	at 20°C (68°F)		
	BJ60	1.2Ω	5.1Ω
	ex. BJ60	0.9Ω	4.3Ω

Overinjection Magnet (Operational Check)

<p>Injection pump lever position</p> <p>A: 4.5° (BJ) 20° (BU, BB)</p> <p>B: 15°</p> <p>C: 25°</p>	<p>BJ Series</p>	<p>BU, BB Series</p>
---	-------------------------	-----------------------------

Starter

Type		12V	24V
Rating output		2.5 kw	4.5 kw
No load characteristics		180 A max. and 3,500 rpm min. at 11V	90 A max. and 3,500 rpm min. at 23V
Mica depth	STD	0.7 – 0.9 mm	0.028 – 0.035 in.
	Limit	0.2 mm	0.008 in.
Commutator runout	STD	Less than 0.05mm (0.0020 in.)	
	Limit	0.05 mm	0.0020 in.
Commutator outer diameter	STD	36 mm	1.42 in.
	Limit	35 mm	1.38 in.
Brush length	STD	20.5 mm	0.807 in.
	Limit	12 mm	0.47 in.
Brush spring tension	STD	3.2 – 4.0 kg	7 – 9 lb

CHARGING SYSTEM

Alternator

Type		12V	24V
Rating output		12V – 40A	24V – 20A, 25A
Rotor coil resistance		2.8 – 3.0Ω	19.0Ω
Brush exposed length	STD	20.0 mm	0.787 in.
	Limit	5.5 mm	0.217 in.

Alternator Regulator

Type		12V	24V
Regulating voltage		13.8 – 14.8V	27 – 29V
Voltage relay actuating voltage		4 – 5.8V	8 – 11.6V

Alternator with IC Regulator

Type		12V	24V
Rating output		12V – 55A	24V – 55A
Rotor coil resistance		2.8 – 3.0Ω	19.0Ω
Brush exposed length	STD	20.0 mm	0.787 in.
	Limit	5.5 mm	0.217 in.
Regulating voltage		13.8 – 14.4V	27.7 – 28.7V